

SUBSEQUENT INSERTIONS

SECOND INSERTION

NOTICE TO CREDITORS
IN THE CIRCUIT COURT IN AND
FOR CHARLOTTE COUNTY,
FLORIDA
PROBATE DIVISION
CASE NO.: 12-1391CP
IN RE: ESTATE OF
RICHARD FRANCIS RACK,
Deceased.

The administration of the Estate of RICHARD FRANCIS RACK, deceased, whose date of death was June 24, 2011; Case Number 12-1391CP, is pending in the Circuit Court for Charlotte County, Florida, Probate Division, the address of which is 350 East Marion Avenue, Punta Gorda, Florida 33950. The names and addresses of the Personal Representative and the Personal Representative's attorney are set forth below.

All creditors of the Decedent and other persons having claims or demands against Decedent's Estate, on whom a copy of this notice is required to be served must file their claims with this Court WITHIN THE LATER OF 3 MONTHS AFTER THE TIME OF THE FIRST PUBLICATION OF THIS NOTICE OR 30 DAYS AFTER THE DATE OF SERVICE OF A COPY OF THIS NOTICE ON THEM.

All other creditors of the Decedent and other persons having claims or demands against Decedent's Estate must file their claims with this Court WITHIN 3 MONTHS AFTER THE DATE OF THE FIRST PUBLICATION OF THIS NOTICE.

ALL CLAIMS NOT FILED WITHIN THE TIME PERIODS SET FORTH IN SECTION 733.702 OF THE FLORIDA PROBATE CODE WILL BE FOREVER BARRED.

NOTWITHSTANDING THE TIME PERIOD SET FORTH ABOVE, ANY CLAIM FILED TWO (2) YEARS OR MORE AFTER THE DECEDENT'S DATE OF DEATH IS BARRED.

The date of first publication of this notice is October 5, 2012.

Kathleen Rack
6273 Roberta Drive
Englewood, Florida 34224
Personal Representative
David A. Yergey, Jr., Esquire
Florida Bar No.: 374288
YERGEY AND YERGEY, P.A.
211 North Magnolia Avenue
Orlando, Florida 32801
Telephone 407-843-0430
Facsimile 407-843-0433
Email david@yergeylaw.com
Secondary Email
noel@yergeylaw.com
Attorney for the Personal
Representative
October 5, 12, 2012 12-0203T

SECOND INSERTION

NOTICE TO CREDITORS
IN THE CIRCUIT COURT FOR
CHARLOTTE COUNTY, FLORIDA
PROBATE DIVISION
File Number 12-1435 CP
IN RE: ESTATE OF
ROLAND M. BOGERT, a/k/a
ROLAND MILLER BOGERT,
Deceased.

The administration of the ancillary ESTATE OF ROLAND M. BOGERT, a/k/a ROLAND MILLER BOGERT, deceased, whose date of death was November 9, 2011, is pending in the Circuit Court for Charlotte County, Florida, Probate Division, File Number 12-1435 CP, the address of which is 350 E. Marion Avenue, Punta Gorda, Florida 33950. The names and addresses of the personal representative and the personal representative's attorney are set forth below.

All creditors of the decedent and other persons having claims or demands against decedent's estate on whom a copy of this notice is has been served must file their claims with this court WITHIN THE LATER OF 3 MONTHS AFTER THE DATE OF THE FIRST PUBLICATION OF THIS NOTICE OR 30 DAYS AFTER THE DATE OF SERVICE OF A COPY OF THIS NOTICE ON THEM.

All other creditors of the decedent and other persons having claims or demands against decedent's estate must file their claims with this court WITHIN 3 MONTHS AFTER THE DATE OF THE FIRST PUBLICATION OF THIS NOTICE.

ALL CLAIMS NOT SO FILED WILL BE FOREVER BARRED.

NOTWITHSTANDING THE TIME PERIOD SET FORTH ABOVE, ANY CLAIM FILED TWO (2) YEARS OR MORE AFTER THE DECEDENT'S DATE OF DEATH IS BARRED.

The date of first publication of this Notice is October 5, 2012.

Personal Representative:
CHARLES L. BOGERT
c/o P.O. Box 3018
Sarasota, Florida 34230
Attorney for Personal
Representative:
RICHARD R. GANS
Florida Bar No. 0040878
FERGESON, SKIPPER,
SHAW, KEYSER, BARON &
TIRABASSI, P.A.
1515 Ringling Boulevard,
10th Floor
P.O. Box 3018
Sarasota, Florida 34230-3018
(941) 957-1900
October 5, 12, 2012 12-0202T

SECOND INSERTION

NOTICE TO CREDITORS
IN THE CIRCUIT COURT FOR
CHARLOTTE COUNTY, FLORIDA
PROBATE DIVISION
File No. 121487CP
IN RE: ESTATE OF
THOMAS A. WAHL
Deceased.

The administration of the estate of Thomas A. Wahl, deceased, whose date of death was July 21, 2012, is pending in the Circuit Court for Charlotte County, Florida, Probate Division, the address of which is Post Office Box 511687, Punta Gorda, FL 33951 1687. The names and addresses of the personal representative and the personal representative's attorney are set forth below.

All creditors of the decedent and other persons having claims or demands against decedent's estate on whom a copy of this notice is required to be served must file their claims with this court WITHIN THE LATER OF 3 MONTHS AFTER THE TIME OF THE FIRST PUBLICATION OF THIS NOTICE OR 30 DAYS AFTER THE DATE OF SERVICE OF A COPY OF THIS NOTICE ON THEM.

All other creditors of the decedent and other persons having claims or demands against decedent's estate must file their claims with this court WITHIN 3 MONTHS AFTER THE DATE OF THE FIRST PUBLICATION OF THIS NOTICE.

ALL CLAIMS NOT FILED WITHIN THE TIME PERIODS SET FORTH IN SECTION 733.702 OF THE FLORIDA PROBATE CODE WILL BE FOREVER BARRED.

NOTWITHSTANDING THE TIME PERIODS SET FORTH ABOVE, ANY CLAIM FILED TWO (2) YEARS OR MORE AFTER THE DECEDENT'S DATE OF DEATH IS BARRED.

The date of first publication of this notice is October 5, 2012.

Personal Representative:
s/Shaneen Wahl
514 Lomond Drive
Port Charlotte, Florida 33953
Attorney for Personal
Representative:
s/Jeffrey M. Backo
Attorney for Shaneen Wahl
Florida Bar Number: 0086426
MELLOR & GRISSINGER
13801 D South Tamiami Trail
North Port, FL 34287
Telephone: (941) 426 1193
Fax: (941) 426 5413
E-Mail: jeff@northportlaw.com
October 5, 12, 2012 12-0209T

SECOND INSERTION

NOTICE TO CREDITORS
IN THE CIRCUIT COURT FOR
CHARLOTTE COUNTY, FLORIDA
PROBATE DIVISION
File No. 12-1527-CP
IN RE: ESTATE OF
LESLIE E. LEWIS
Deceased.

The administration of the estate of Leslie E. Lewis, deceased, whose date of death was May 4, 2012, is pending in the Circuit Court for Charlotte County, Florida, Probate Division, the address of which is 350 East Marion Avenue, Punta Gorda, Florida 33950; PO Box 511687 Punta Gorda, FL 33915. The names and addresses of the personal representatives and the personal representatives' attorney are set forth below.

All creditors of the decedent and other persons having claims or demands against decedent's estate on whom a copy of this notice is required to be served must file their claims with this court WITHIN THE LATER OF 3 MONTHS AFTER THE TIME OF THE FIRST PUBLICATION OF THIS NOTICE OR 30 DAYS AFTER THE DATE OF SERVICE OF A COPY OF THIS NOTICE ON THEM.

All other creditors of the decedent and other persons having claims or demands against decedent's estate must file their claims with this court WITHIN 3 MONTHS AFTER THE DATE OF THE FIRST PUBLICATION OF THIS NOTICE.

ALL CLAIMS NOT FILED WITHIN THE TIME PERIODS SET FORTH IN SECTION 733.702 OF THE FLORIDA PROBATE CODE WILL BE FOREVER BARRED.

NOTWITHSTANDING THE TIME PERIODS SET FORTH ABOVE, ANY CLAIM FILED TWO (2) YEARS OR MORE AFTER THE DECEDENT'S DATE OF DEATH IS BARRED.

The date of first publication of this notice is October 5, 2012.

Personal Representatives:
Milton L. Lewis
1375 Holiday Drive
Englewood, Florida 34223
Linda Lipstein
1820 Gulf Boulevard
Englewood, Florida 34223
Attorney for Personal
Representatives:
Mary Ann Floyd
Attorney for Milton L. Lewis
Attorney for Linda Lipstein
Florida Bar Number: 0115746
DIEZ & FLOYD, P.A.
737 South Indiana Avenue
Englewood, Florida 34223
Telephone: (941) 474-5506
Fax: (941) 474-5507
Florida Bar No. 488585
E-Mail Address:
diezandfloyd@verizon.net
October 5, 12, 2012 12-0208T

SECOND INSERTION

NOTICE OF RESCHEDULED
FORECLOSURE SALE
IN THE CIRCUIT COURT OF THE
TWENTIETH JUDICIAL CIRCUIT
IN AND FOR CHARLOTTE
COUNTY, FLORIDA
CIVIL ACTION
CASE NO.: 08-2009-CA-006267
U.S. BANK NATIONAL
ASSOCIATION, AS TRUSTEE, FOR
JPM ALT 2005-ALT2,
Plaintiff, vs.
DOREEN M. BURKE A/K/A
DORREEN BURKE HERBERT,
et al.
Defendant(s).

NOTICE IS HEREBY GIVEN pursuant to an Order Rescheduling Foreclosure Sale dated September 25, 2012 and entered in Case NO. 08-2009-CA-006267 of the Circuit Court of the TWENTIETH Judicial Circuit in and for CHARLOTTE County, Florida wherein U.S. BANK NATIONAL ASSOCIATION, AS TRUSTEE, FOR JPM ALT 2005-ALT2, is the Plaintiff and DOREEN M. BURKE A/K/A DORREEN BURKE HERBERT; CORY HERBERT A/K/A CORY M. HERBERT; are the Defendants, The Clerk of the Court will sell to the highest and best bidder for cash at WWW.CHARLOTTE.REALFORECLOSE.COM in accordance with Chapter 45 Florida Statutes at 11:00AM, on the 22nd day of October, 2012, the following described property as set forth in said Final Judgment:

LOT 25, BLOCK 8, OF TEE AND GREEN ESTATES, ACCORDING TO THE PLAT THEREOF AS RECORDED IN PLAT BOOK 4, PAGE 18, OF THE PUBLIC RECORDS OF CHARLOTTE COUNTY, FLORIDA.
A/K/A 4628 LAGORCE DRIVE, PUNTA GORDA, FL 33982

Any person claiming an interest in the surplus from the sale, if any, other than the property owner as of the date of the Lis Pendens must file a claim within sixty (60) days after the sale.

If you are a person with a disability who needs any accommodation in order to participate in this proceeding, you are entitled, at no cost to you, to the provision of certain assistance. Please contact Jon Embury, Administrative Services Manager, whose office is located at 350 E. Marion Avenue, Punta Gorda, Florida 33950, and whose telephone number is (941) 637-2110, at least 7 days before your scheduled court appearance, or immediately upon receiving this notification if the time before the scheduled appearance is less than 7 days; if you are hearing or voice impaired, call 711.

WITNESS MY HAND and the seal of this Court on October 1st, 2012

Barbara T. Scott
Clerk of the Circuit Court
(SEAL) By: Jennifer Miles
Deputy Clerk
RONALD R WOLFE &
ASSOCIATES, P.L.
P.O. Box 25018
Tampa, Florida 33622-5018
F09110835
October 5, 12, 2012 12-0206T

SECOND INSERTION

NOTICE OF FORECLOSURE SALE
IN THE CIRCUIT COURT OF THE
TWENTIETH JUDICIAL
CIRCUIT, IN AND FOR
CHARLOTTE COUNTY, FLORIDA
GENERAL JURISDICTION
DIVISION
CASE NO. 11002990CA
CITIMORTGAGE, INC.,
Plaintiff, vs.
GERALD MELL A/K/A GERALD L.
MELL, et al.
Defendant.

NOTICE IS HEREBY GIVEN pursuant to a Final Judgment of Foreclosure dated September 25, 2012, and entered in 11002990CA of the Circuit Court of the Twentieth Judicial Circuit in and for Charlotte County, Florida, wherein CITIMORTGAGE, INC., is the Plaintiff and GERALD MELL A/K/A GERALD L. MELL; UNKNOWN SPOUSE OF GERALD L. MELL; FIRST COMMUNITY BANK OF AMERICA, N.A.; are the Defendant(s). Barbara Scott as the Clerk of the Circuit Court will sell to the highest and best bidder for cash at www.charlotte.realforeclose.com, at 11:00 am on November 30, 2012, the following described property as set forth in said Final Judgment, to wit:

LOT 22, BLOCK 1062, PORT CHARLOTTE SUBDIVISION, SECTION 14, A SUBDIVISION, ACCORDING TO THE PLAT THEREOF, AS RECORDED IN PLAT BOOK 5, PAGES 3-A THROUGH 3-E, INCLUSIVE, OF THE PUBLIC RECORDS OF CHARLOTTE COUNTY, FLORIDA.

Any person claiming an interest in the surplus from the sale, if any, other than the property owner as of the date of the lis pendens must file a claim within 60 days after the sale.

If you are a person with a disability who needs any accommodation in order to participate in this proceeding, you are entitled, at no cost to you, to the provision of certain assistance. Please contact Jon Embury, Administrative Services Manager, whose office is located at 350 E. Marion Avenue, Punta Gorda, Florida 33950, and whose telephone number is (941) 637-2110, at least 7 days before your scheduled court appearance, or immediately upon receiving this notification if the time before the scheduled appearance is less than 7 days; if you are hearing or voice impaired, call 711.

Dated this 27th day of September, 2012

Barbara Scott
As Clerk of the Court
(SEAL) By: Jennifer Miles
As Deputy Clerk

ROBERTSON, ANSCHUTZ &
SCHNEID, P.L.
Attorneys for Plaintiff
3010 N. Military Trail, Suite 300
Boca Raton, FL 33431
Telephone: 561-241-6901
Fax: 561-241-9181
11-08546
October 5, 12, 2012 12-0196T

SECOND INSERTION

NOTICE OF FORECLOSURE SALE
IN THE CIRCUIT COURT OF THE
20TH JUDICIAL CIRCUIT, IN
AND FOR CHARLOTTE COUNTY,
FLORIDA
CIVIL DIVISION
CASE NO.: 11003089CA

FANNIE MAE ("FEDERAL NATIONAL MORTGAGE ASSOCIATION"), Plaintiff, vs. MENA JUAN; DEEP CREEK GARDENS CONDOMINIUM ASSOCIATION, INC.; ISHMILE JUMAN; KRYSYLE JUMAN; UNKNOWN TENANT IN POSSESSION OF THE SUBJECT PROPERTY, Defendants.

NOTICE IS HEREBY GIVEN pursuant to a Final Judgment of Foreclosure dated the 25th day of September, 2012, and entered in Case No. 11003089CA, of the Circuit Court of the 20TH Judicial Circuit in and for Charlotte County, Florida, wherein FANNIE MAE ("FEDERAL NATIONAL MORTGAGE ASSOCIATION") is the Plaintiff and MENA JUAN, DEEP CREEK GARDENS CONDOMINIUM ASSOCIATION, INC., ISHMILE JUMAN, KRYSYLE JUMAN and UNKNOWN TENANT(S) IN POSSESSION OF THE SUBJECT PROPERTY are defendants. The Clerk of this Court shall sell to the highest and best bidder for cash electronically at www.charlotte.realforeclose.com in accordance with Chapter 45, Florida Statutes at 11:00 AM on the 26th day of December, 2012, the following described property as set forth in said Final Judgment, to wit:

UNIT V-203, DEEP CREEK GARDENS, PHASE 13, A CONDOMINIUM ACCORDING TO THE DECLARATION OF CONDOMINIUM FILED IN OFFICIAL RECORDS BOOK 879, PAGE 1241, AND AMENDMENTS THERETO OF THE PUBLIC RECORDS OF CHARLOTTE COUNTY, FLORIDA AND ACCORD-

ING TO THE GRAPHIC DESCRIPTION CONTAINED IN CONDOMINIUM BOOK 6, PAGES 44A THRU 44M, AND AMENDMENTS THERETO OF THE PUBLIC RECORDS OF CHARLOTTE COUNTY, FLORIDA, TOGETHER WITH THE COMMON ELEMENTS APPURTENANT THERETO, AS DESCRIBED IN THE DECLARATION

ANY PERSON CLAIMING AN INTEREST IN THE SURPLUS FROM THE SALE, IF ANY, OTHER THAN THE PROPERTY OWNER AS OF THE DATE OF THE LIS PENDENS MUST FILE A CLAIM WITHIN 60 DAYS AFTER THE SALE.

If you are a person with a disability who needs any accommodation in order to participate in this proceeding, you are entitled, at no cost to you, to the provision of certain assistance. Please contact Jon Embury, Administrative Services Manager, whose office is located at 350 E. Marion Avenue, Punta Gorda, Florida 33950, and whose telephone number is (941) 637-2110, at least 7 days before your scheduled court appearance, or immediately upon receiving this notification if the time before the scheduled appearance is less than 7 days; if you are hearing or voice impaired, call 711.

Dated this 27th day of September, 2012.

BARBARA T. SCOTT
Clerk of the Circuit Court
(SEAL) By: Jennifer Miles
Deputy Clerk
LAW OFFICES OF MARSHALL C.
WATSON, P.A.
1800 NW 49th Street, Suite 120
Fort Lauderdale, Florida 33309
Telephone: (954) 453-0365
Facsimile: (954) 771-6052
Toll Free: 1-800-441-2438
DESIGNATED PRIMARY E-MAIL
FOR SERVICE PURSUANT TO FLA
R. JUD. ADMIN 2.516
eservice@marshallwatson.com
10-22318
October 5, 12, 2012 12-0199T

SECOND INSERTION

NOTICE OF FORECLOSURE SALE
IN THE CIRCUIT COURT OF THE
TWENTIETH JUDICIAL
CIRCUIT, IN AND FOR
CHARLOTTE COUNTY, FLORIDA
CIVIL DIVISION
Case No.: 2012-CA-001000

BANK OF AMERICA, N.A. SUCCESSOR BY MERGER TO BAC HOME LOANS SERVICING, LP F/K/A COUNTRYWIDE HOME LOANS SERVICING, LP, Plaintiff, v. JUAN C. TRIANA A/K/A J.C.T; et al., Defendants,

NOTICE IS HEREBY GIVEN pursuant to a Final Summary Judgment dated September 28, 2012, entered in Civil Case No.: 2012-CA-001000, of the Circuit Court of the Twentieth Judicial Circuit in and for Charlotte County, Florida, wherein BANK OF AMERICA, N.A. SUCCESSOR BY MERGER TO BAC HOME LOANS SERVICING, LP F/K/A COUNTRYWIDE HOME LOANS SERVICING, LP, is Plaintiff, and JUAN C. TRIANA A/K/A J.C.T.; SOLEDAD TRIANA A/K/A SOLEDAD TRAINA; JPMORGANCHASE BANK, NATIONAL ASSOCIATION SUCCESSOR BY MERGER TO WASHINGTON MUTUAL BANK F/K/A WASHINGTON MUTUAL BANK, FEDERAL ASSOCIATION; BURNT STORE VILLAGE PROPERTY OWNERS ASSOCIATION, INC.; UNKNOWN TENANT #1; UNKNOWN TENANT #2; ALL OTHER UNKNOWN PARTIES CLAIMING INTERESTS BY, THROUGH, UNDER, AND AGAINST A NAMED DEFENDANT(S) WHO ARE NOT KNOWN TO BE DEAD OR ALIVE, WHETHER SAME UNKNOWN PARTIES MAY CLAIM AN INTEREST AS SPOUSES, HEIRS, DEVISEES, GRANTEES, OR OTHER CLAIMANTS, are Defendants.

BARBARA T. SCOTT, the Clerk of the Court shall sell to the highest bidder for cash at 11:00 a.m., online at www.charlotte.realforeclose.com on the 28th day of November, 2012 the following described real property as

set forth in said Final Summary Judgment, to wit:

LOT 8, BLOCK 323 OF PUNTA GORDA ISLES, SECTION 16, ACCORDING TO THE PLAT THEREOF, AS RECORDED IN PLAT BOOK 8, PAGE(S) 27A-27O, INCLUSIVE, OF THE PUBLIC RECORDS OF CHARLOTTE COUNTY, FLORIDA.

This property is located at the Street address of: 25409 DURANGO COURT, PUNTA GORDA, FL 33955.

If you are a person claiming a right to funds remaining after the sale, you must file a claim with the clerk no later than 60 days after the sale. If you fail to file a claim you will not be entitled to any remaining funds. After 60 days, only the owner of record as of the date of the lis pendens may claim the surplus.

If you are a person with a disability who needs any accommodation in order to participate in this proceeding, you are entitled, at no cost to you, to the provision of certain assistance. Please contact Jon Embury, Administrative Services Manager, whose office is located at 350 E. Marion Avenue, Punta Gorda, Florida 33950, and whose telephone number is (941) 637-2110, at least 7 days before your scheduled court appearance, or immediately upon receiving this notification if the time before the scheduled appearance is less than 7 days; if you are hearing or voice impaired, call 711.

WITNESS my hand and the seal of the court on October 1st, 2012.

BARBARA T. SCOTT
CLERK OF THE COURT
(COURT SEAL) by: Jennifer Miles
Deputy Clerk
Attorney for Plaintiff:
ELIZABETH R. WELLBORN, P.A.
350 Jim Moran Blvd. Suite 100
Deerfield Beach, FL 33442
Telephone: (954) 354-3544
Facsimile: (954) 354-3545
8377-35037
October 5, 12, 2012 12-0205T

SECOND INSERTION

NOTICE OF FORECLOSURE SALE
IN THE CIRCUIT COURT OF THE
20TH JUDICIAL CIRCUIT, IN
AND FOR CHARLOTTE COUNTY,
FLORIDA
CIVIL DIVISION
CASE NO.: 11-3824-CA

BANK OF AMERICA, N.A., Plaintiff, vs. DAVID JOHN PITERSKI A/K/A DAVID J. PITERSKI; UNKNOWN TENANT (S); IN POSSESSION OF THE SUBJECT PROPERTY, Defendants.

NOTICE IS HEREBY GIVEN pursuant to a Final Judgment of Foreclosure dated the 18th day of July, 2012, and entered in Case No. 11-3824-CA, of the Circuit Court of the 20TH Judicial Circuit in and for Charlotte County, Florida, wherein BANK OF AMERICA N.A. is the Plaintiff and DAVID JOHN PITERSKI A/K/A DAVID J. PITERSKI and UNKNOWN TENANT(S) IN POSSESSION OF THE SUBJECT PROPERTY are defendants. The Clerk of this Court shall sell to the highest and best bidder for cash electronically at www.charlotte.realforeclose.com in accordance with Chapter 45, Florida Statutes at 11:00 AM on the 7th day of January, 2013, the following described property as set forth in said Final Judgment, to wit:

LOT 25, BLOCK 92, UNIT 6, TROPICAL GULF ACRES, A SUBDIVISION ACCORDING TO THE PLAT THEREOF, RECORDED IN PLAT BOOK 3, PAGE 67A THROUGH 67F, OF THE PUBLIC RECORDS OF CHARLOTTE COUNTY, FLORIDA.
PROPERTY ADDRESS: 12139

BORAX AVENUE, PUNTA GORDA, FL 33955
ANY PERSON CLAIMING AN INTEREST IN THE SURPLUS FROM THE SALE, IF ANY, OTHER THAN THE PROPERTY OWNER AS OF THE DATE OF THE LIS PENDENS MUST FILE A CLAIM WITHIN 60 DAYS AFTER THE SALE.

If you are a person with a disability who needs any accommodation in order to participate in this proceeding, you are entitled, at no cost to you, to the provision of certain assistance. Please contact Jon Embury, Administrative Services Manager, whose office is located at 350 E. Marion Avenue, Punta Gorda, Florida 33950, and whose telephone number is (941) 637-2110, at least 7 days before your scheduled court appearance, or immediately upon receiving this notification if the time before the scheduled appearance is less than 7 days; if you are hearing or voice impaired, call 711.

Dated this 1st day of October, 2012.

BARBARA T. SCOTT
Clerk of the Circuit Court
(SEAL) By: Jennifer Miles
Deputy Clerk

LAW OFFICES OF MARSHALL C.
WATSON, P.A.
1800 NW 49th Street, Suite 120
Fort Lauderdale, Florida 33309
Telephone: (954) 453-0365
Facsimile: (954) 771-6052
Toll Free: 1-800-441-2438
DESIGNATED PRIMARY E-MAIL
FOR SERVICE PURSUANT TO FLA
R. JUD. ADMIN 2.516
eservice@marshallwatson.com
10-49444
October 5, 12, 2012 12-0204T

SARASOTA COUNTY

FIRST INSERTION

Notice Under Fictitious Name Law Pursuant to Section 865.09, Florida Statutes
NOTICE IS HEREBY GIVEN that JaRaLa Americano, LLC, a Florida limited liability company, located at 1409 Main Street, Sarasota, Florida, Sarasota County, intends to transact business under the fictitious name of Cafe Americano, and to register said fictitious name with the Division of Corporations of the Florida Department of State, Tallahassee, Florida. Dated this 5th day of October 2012.
October 12, 2012 12-3955S

FIRST INSERTION

NOTICE OF PUBLIC SALE TO BE HELD AT: THE LOCK TITE SELF STORAGE 4625 CLARK ROAD, SARASOTA, FL 34233 941-923-9595 PHONE
DATE: Oct. 27, 2012 BEGINS AT: 1:00 PM

CONDITIONS: Units will be sold to the highest bidder. Bids taken for each unit in its entirety. Payment must be made by CASH. All goods must be removed within 24 hours. Payment is due upon acceptance of bid. Unit availability subject to prior settlement of account.

Unit 2021, Mark Moncelli Approx. (10' x 25') Household Items

Unit 2029, Mark Moncelli Approx. (10' x 30') Household Items

Unit 3151, Lisa Pultz Approx. (10' x 15') Household Items
October 12, 19, 2012 12-3914S

FIRST INSERTION

Notice of Landowners Meeting for the River Road at Center Road Community Development District
Notice is hereby given to all landowners within the River Road at Center Road Community Development District (the "District"). A tract of land lying in Sections 19 and 20, Township 39 South, Range 20 East all within Sarasota County, Florida. A meeting of the landowners will be held for the purpose of electing five District supervisors.
Date: Tuesday, November 6, 2012
Time: 1:30 p.m.
Place: 5800 Lakewood Ranch Blvd., Sarasota, FL 34240

Each landowner may vote in person or by written proxy. Proxy forms may be obtained upon request from the District Manager, 12051 Corporate Blvd., Orlando, Florida 32817 (407) 382-3256. At said meeting each landowner or the landowner's proxy shall be entitled to cast one vote per acre of land owned by the landowner and located within the District for each person to be elected. A fraction of an acre shall be treated as one acre.

Immediately following the landowners meeting there will be convened the regular meeting of the Board of supervisors. The meeting is open to the public and will be conducted in accordance with the provisions of Florida Law for Community Development Districts.

Each person who decides to appeal any action taken at these meetings is advised that person will need a record of the proceedings and that accordingly, the person may need to ensure that a verbatim record of the proceedings is made, including the testimony and evidence upon which such appeal is to be based.

Jill Cupps
District Manager
October 12, 19, 2012 12-3912S

FIRST INSERTION

NOTICE TO CREDITORS IN THE CIRCUIT COURT FOR SARASOTA COUNTY, FLORIDA PROBATE DIVISION
File No. 2012CP-3595-NC
IN RE: ESTATE OF ALICIA B. TORRENCE-BURY, Deceased.

The administration of the estate of ALICIA B. TORRENCE-BURY, deceased, whose date of death was September 6, 2012; File Number 2012CP-3595-NC, is pending in the Circuit Court for Sarasota County, Florida, Probate Division, the address of which is P.O. Box 3079, Sarasota, FL 34230. The names and addresses of the personal representative and the personal representative's attorney are set forth below.

All creditors of the decedent and other persons having claims or demands against decedent's estate, on whom a copy of this notice is required to be served must file their claims with this court WITHIN THE LATER OF 3 MONTHS AFTER THE TIME OF THE FIRST PUBLICATION OF THIS NOTICE OR 30 DAYS AFTER THE DATE OF SERVICE OF A COPY OF THIS NOTICE ON THEM.

All other creditors of the decedent

FIRST INSERTION

NOTICE UNDER FICTITIOUS NAME LAW
Pursuant to F.S. §865.09; NOTICE IS HEREBY GIVEN, the undersigned, desiring to engage in business under the fictitious name of MR. METICULOUS - CUSTOM BUILDING & REMODELING, located at 2754 Orchid Oaks Dr., A-204, County of Sarasota, State of Florida, 34239, intends to register the name with the Division of Corporations of the Florida Department of State, Tallahassee, Florida.
Dated this 5th day of October, 2012.
October 12, 2012 12-3916S

FIRST INSERTION

Notice of Public Auction Pursuant F.S. 328.17, United American Lien & Recovery as agent w/ power of attorney will sell the following vessel(s) to the highest bidder. Inspect 1 week prior @ marina; cash or cashier check; 18% buyer prem; all auctions are held w/ reserve; any persons interested ph 954-563-1999

Sale Date November 2 2012 @ 10:00 am 3411 NW 9th Ave #707 Ft Lauderdale FL 33309

V11936 1988 BL41 FL9304GB hull id#: BL4C84CKJ788 in/outboard pleasure gas fiberglass L18ft r/o peter michael cataldo lienor: tesoro del mar inc 6135 palmer blvd #b1 sarasota fl

Licensed Auctioneers FLAB422 FLAU765 & 1911

October 12, 19, 2012 12-3983S

FIRST INSERTION

Notice of Landowners Meeting for the Blackburn Creek Community Development District
Notice is hereby given to all landowners within the Blackburn Creek Community Development District (the "District"). A tract of land lying in Sections 19 and 20, Township 36 South, Range 20 East all within Sarasota County, Florida. A meeting of the landowners will be held for the purpose of electing three (3) District supervisors.
Date: Tuesday, November 6, 2012
Time: 1:30 p.m.
Place: 5800 Lakewood Ranch Blvd., Sarasota, FL 34240

Each landowner may vote in person or by written proxy. Proxy forms may be obtained upon request from the District Manager, 12051 Corporate Blvd., Orlando, Florida 32817 (407) 382-3256. At said meeting each landowner or the landowner's proxy shall be entitled to cast one vote per acre of land owned by the landowner and located within the District for each person to be elected. A fraction of an acre shall be treated as one acre.

Immediately following the landowners meeting there will be convened the regular meeting of the Board of supervisors. The meeting is open to the public and will be conducted in accordance with the provisions of Florida Law for Community Development Districts.

Each person who decides to appeal any action taken at these meetings is advised that person will need a record of the proceedings and that accordingly, the person may need to ensure that a verbatim record of the proceedings is made, including the testimony and evidence upon which such appeal is to be based.

Jill Cupps
District Manager
October 12, 19, 2012 12-3911S

FIRST INSERTION

and other persons having claims or demands against decedent's estate must file their claims with this court WITHIN 3 MONTHS AFTER THE DATE OF THE FIRST PUBLICATION OF THIS NOTICE.

ALL CLAIMS NOT FILED WITHIN THE TIME PERIODS SET FORTH IN SECTION 733.702 OF THE FLORIDA PROBATE CODE WILL BE FOREVER BARRED.

NOTWITHSTANDING THE TIME PERIOD SET FORTH ABOVE, ANY CLAIM FILED TWO (2) YEARS OR MORE AFTER THE DECEDENT'S DATE OF DEATH IS BARRED.

The date of first publication of this notice is: October 12, 2012.

BEVERLY FESSENDEN
Personal Representative
511 Spring Lake Circle
Tarpon Springs, FL 34688

H. GREG LEE
Attorney for Personal Representative
Email: hglee@hgreglee.com
Florida Bar No. 351301
H. GREG LEE, P.A.
2014 Fourth Street
Sarasota, Florida 34237
Telephone: (941) 954-0067
Facsimile: (941) 365-1492
October 12, 19, 2012 12-3967S

FIRST INSERTION

NOTICE OF PUBLIC SALE: J&G WFR Inc dba Direct Towing gives Notice of Foreclosure of Lien and intent to sell these vehicles on 10/26/2012 9:00:00 AM at 3951 N Osprey Ave, Sarasota, FL 34234 pursuant to subsection 713.78 of the Florida Statutes. J&G WFR Inc dba Direct Towing reserves the right to accept or reject any and/or all bids.

YV1AA8842L1401176	1990 VOLV	
1FMCA11U2KZA85273	1989 FORD Aerostar	
1FDWF36PX5EB23387	2005 FORD F-350 SD	
171881627	2003 Schwing P-88D	
October 12, 2012		12-3915S

FIRST INSERTION

Notice of Public Auction
Notice is hereby given that Hide Away Storage Services, LLC will sell the items below at a public auction to the highest bidder to be held at 8901; S. Tamiami Trail Sarasota, FL 34238 on Tuesday, October 30, 2012 at 9:00 AM. Personal belongings for: 00134-James Conteri-TV, Household Goods, Fishing Poles, Stereo Equipment
00765-Kenny Ferebee- Household goods, High Chair, Vacuum
00663-Lisa Hughes-Household Goods, Boxes
00923-Perry Feinberg-Boxes, TV, Household Goods
M02620-Ashlee Cole-Boxes, Plastic Bins
M02174-Ashlee Cole- Plastic Bins, Household Goods
M000438-Robert Speer-Boxes, Household Goods
M001689-Robert Speer-Boxes, Household Goods

Notice is hereby given that Hide Away Storage Services, LLC will sell the items below at a public auction to the highest bidder to be held at 335 South Beneva Road; Sarasota, FL 34232 on Tuesday, October 30, 2012 at 10:00 AM. Personal Belongings For: 00139-Charles Leo Scherry -Household goods
00648-Rhonda Jordan-Chair, file cabinet
00809-Janine Dix-Household goods, tv, boxes, washer & dryer
00817-Brian Lewendowski -Ladder, household goods, lawn mower

FIRST INSERTION

NOTICE TO CREDITORS IN THE CIRCUIT COURT FOR SARASOTA COUNTY, FLORIDA PROBATE DIVISION
File No. 2012 CP 003637 NC
IN RE: ESTATE OF JOHN F. CRAIG A/K/A JOHN FARRELL CRAIG, JR., DECEASED.

The administration of the estate of JOHN F. CRAIG A/K/A JOHN FARRELL CRAIG, JR., deceased, whose date of death was September 1, 2012; File Number 2012CP003637NC, is pending in the Circuit Court for Sarasota County, Florida, Probate Division, the address of which is 2000 Main St., Sarasota, FL 34237. The names and addresses of the personal representative and the personal representative's attorney are set forth below.

All creditors of the decedent and other persons having claims or demands against decedent's estate, on whom a copy of this notice is required to be served must file their claims with this court WITHIN THE LATER OF 3 MONTHS AFTER THE TIME OF THE FIRST PUBLICATION OF THIS NOTICE OR 30 DAYS AFTER THE DATE OF SERVICE OF A COPY OF THIS NOTICE ON THEM.

All other creditors of the decedent and other persons having claims or demands against decedent's estate must file their claims with this court WITHIN 3 MONTHS AFTER THE DATE OF THE FIRST PUBLICATION OF THIS NOTICE.

ALL CLAIMS NOT FILED WITHIN THE TIME PERIODS SET FORTH IN SECTION 733.702 OF THE FLORIDA PROBATE CODE WILL BE FOREVER BARRED.

NOTWITHSTANDING THE TIME PERIOD SET FORTH ABOVE, ANY CLAIM FILED TWO (2) YEARS OR MORE AFTER THE DECEDENT'S DATE OF DEATH IS BARRED.

The date of first publication of this notice is: October 12, 2012.

CYNTHIA M. CRAIG
Personal Representative
c/o Michael L. Foreman
Email: mforeman@icardmerrill.com
Icard, Merrill, Cullis, Timm
Furen & Ginsburg, P.A.
2033 Main St.
Suite 600
Sarasota, FL 34237
Telephone: 941-366-8100
Fax 941-366-6384

Michael L. Foreman
Attorney for Personal Representative
Email: mforeman@icardmerrill.com
Florida Bar No. 0118485
ICARD, MERRILL, CULLIS, TIMM
FUREN & GINSBURG, P.A.
2033 Main St.
Suite 600
Sarasota, FL 34237
Telephone: 941-366-8100
Fax 941-366-6384
October 12, 19, 2012 12-3965S

01015-Jay Hartley-Household goods, boxes
01208-Janine Dix-Household goods, tools, lawn mower, bicycles
M09464 Arthur Burgess-Boxes, plastic plants
M00590 Arthur Burgess-Boxes, household goods
M00417 Arthur Burgess- Boxes, rugs
M00463 Arthur Burgess-Boxes, household goods
M00386 Arthur Burgess - Boxes, household goods
M00385 Arthur Burgess- boxes, household goods
M00400 Arthur Burgess-Boxes, household goods
M00599 Joseph Miller- Boxes, plastic bins, tv

Notice is hereby given that Hide Away Storage Services, LLC will sell the items below at a public auction to the highest bidder to be held at 2590 17th Street; Sarasota, FL 34234 on Tuesday, October 30, 2012 at 11:00 AM. Personal belongings for:

156-Twanita Dixon-Boxes,
351-Zenda Mayer-Boxes, Suitcases
852-Michael Ward-Household goods, fishing poles
1128-Jose Chavez-Tools, boxes
1157-Wendy Dimeo-Household goods, boxes
1199-Jason Tutt-Household goods, TV
1303-Carmen Atkins-Household goods
1318-Tsaddock Porter-Household goods
1324-Elena Gerard-Household goods, boxes, tools
1408-Stefanny Pretto-Tools, household goods
October 12, 19, 2012 12-3913S

FIRST INSERTION

NOTICE TO CREDITORS IN THE CIRCUIT COURT FOR SARASOTA COUNTY, FLORIDA PROBATE DIVISION
File No. 2012CP003545NC
IN RE: ESTATE OF SELMA N. MANNHEIMER A/K/A SELMA NOREENE MANNHEIMER, DECEASED.

The administration of the estate of SELMA N. MANNHEIMER A/K/A SELMA NOREENE MANNHEIMER deceased, whose date of death was August 30, 2012; File Number 2012CP003545NC, is pending in the Circuit Court for Sarasota County, Florida, Probate Division, the address of which is 2000 Main St., Sarasota, FL 34237. The names and addresses of the personal representative and the personal representative's attorney are set forth below.

All creditors of the decedent and other persons having claims or demands against decedent's estate, on whom a copy of this notice is required to be served must file their claims with this court WITHIN THE LATER OF 3 MONTHS AFTER THE TIME OF THE FIRST PUBLICATION OF THIS NOTICE OR 30 DAYS AFTER THE DATE OF SERVICE OF A COPY OF THIS NOTICE ON THEM.

All other creditors of the decedent and other persons having claims or demands against decedent's estate must file their claims with this court WITHIN 3 MONTHS AFTER THE DATE OF THE FIRST PUBLICATION OF THIS NOTICE.

ALL CLAIMS NOT FILED WITHIN THE TIME PERIODS SET FORTH IN SECTION 733.702 OF THE FLORIDA PROBATE CODE WILL BE FOREVER BARRED.

NOTWITHSTANDING THE TIME PERIOD SET FORTH ABOVE, ANY CLAIM FILED TWO (2) YEARS OR MORE AFTER THE DECEDENT'S DATE OF DEATH IS BARRED.

The date of first publication of this notice is: October 12, 2012.

MARTIN MANNHEIMER
Personal Representative
Email: bchapnick@icardmerrill.com
Icard, Merrill, Cullis, Timm
Furen & Ginsburg, P.A.
2033 Main St.
Suite 600
Sarasota, FL 34237
Telephone: 941-366-8100;
Fax 941-366-6384

Bruce P. Chapnick
Attorney for Personal Representative
Email: bchapnick@icardmerrill.com
Florida Bar No. 0078409
ICARD, MERRILL, CULLIS, TIMM
FUREN & GINSBURG, P.A.
2033 Main St.
Suite 600
Sarasota, FL 34237
Telephone: 941-366-8100;
Fax: 941-366-6384
October 12, 19, 2012 12-3966S

FIRST INSERTION

Notice is hereby given that on 10/26/12 at 10:30 am, the following mobile home will be sold at public auction pursuant to F.S. 715.109: 1977 TRDE #3840A & 3840B. Last Tenant: Champa P Singh. Sale to be held at MHC Bay Indies LLC 950 Ridgewood Ave. Venice, FL 34285 813-241-8269

October 12, 19, 2012 12-3968S

FIRST INSERTION

NOTICE TO CREDITORS IN THE CIRCUIT COURT IN AND FOR SARASOTA COUNTY, FLORIDA
PROBATE DIVISION
FILE NO. 2012 CP 003672NC
IN RE: The Estate of AUSTIN L. SCOFIELD, Deceased
The administration of the estate of Austin L. Scofield, deceased, whose date of death was August 2, 2012, is pending in the Circuit Court for the Twelfth Circuit, Sarasota County, Florida, Probate Division, the address of which is 2000 Main Street, Sarasota, FL 34237. The names and addresses of the personal representative and the personal representative's attorney are set forth below.

All creditors of the decedent and other persons having claims or demands against decedent's estate on whom a copy of this notice is required to be served must file their claims with this court WITHIN THE LATER OF 3 MONTHS AFTER THE TIME OF THE FIRST PUBLICATION OF THIS NOTICE OR 30 DAYS AFTER THE DATE OF SERVICE OF A COPY OF THIS NOTICE ON THEM.

All other creditors of the decedent and other persons having claims or demands against decedent's estate must file their claims with this court WITHIN 3 MONTHS AFTER THE DATE OF THE FIRST PUBLICATION OF THIS NOTICE.

ALL CLAIMS NOT FILED WITHIN THE TIME PERIODS SET FORTH IN SECTION 733.702 OF THE FLORIDA PROBATE CODE WILL BE FOREVER BARRED.

NOTWITHSTANDING THE TIME PERIODS SET FORTH ABOVE, ANY CLAIM FILED TWO (2) YEARS OR MORE AFTER THE DECEDENT'S DATE OF DEATH IS BARRED.

The date of first publication of this notice is October 12, 2012.

Person Giving Notice:
Maritza L. Pemberton
4331 Pine Meadow Lane
Sarasota, FL 34233

Attorney for Person Giving Notice:
Kevin Pillion, Esq.
FL Bar No. 70288
LIFE PLANNING LAW FIRM, P.A.
1990 Main Street, Suite 750
Sarasota, FL 34236
Telephone: (941) 201-1111
October 12, 19, 2012 12-3906S

FIRST INSERTION

NOTICE TO CREDITORS IN THE CIRCUIT COURT OF SARASOTA COUNTY, FLORIDA PROBATE DIVISION
FILE NO. 2012CP001823NC
IN RE: ESTATE OF DAVID J. MARTIN, Deceased

The administration of the Estate of DAVID J. MARTIN, Deceased, File Number 2012CP001823NC, is pending in the Circuit Court for Sarasota County, Florida, Probate Division, the address of which is 2000 Main Street, Sarasota, FL 34237. The names and addresses of the Personal Representative and the Personal Representative's attorney are set forth below.

All creditors of the decedent and other persons having claims or demands against decedent's estate on whom a copy of this notice is required to be served must file their claims with this court WITHIN THE LATER OF THREE MONTHS AFTER THE DATE OF THE FIRST PUBLICATION OF THIS NOTICE OR THIRTY DAYS AFTER THE DATE OF SERVICE OF A COPY OF THIS NOTICE ON THEM.

All other creditors of the decedent and other persons having claims or demands against the decedent's estate must file their claims with this court WITHIN THREE MONTHS AFTER THE DATE OF THE FIRST PUBLICATION OF THIS NOTICE.

ALL CLAIMS NOT SO FILED WILL BE FOREVER BARRED.

NOTWITHSTANDING THE TIME PERIODS SET FORTH ABOVE, ANY CLAIM FILED TWO (2) YEARS OR MORE AFTER THE DECEDENT'S DATE OF DEATH IS BARRED.

The date of first publication of this notice is October 12, 2011.

CAMERON D. MARTIN
Personal Representative
134 Glenfield Avenue
Stratford, CT 06614
HARVEY, WADDELL,
MONAHAN & LAYTON
Atty's for Personal Rep.
101 North J Street
Lake Worth, FL 33460
561-585-4631
By: Daniel L. Monahan
Florida Bar No. 152084
October 12, 19, 2012 12-3954S

FIRST INSERTION

NOTICE TO CREDITORS IN THE CIRCUIT COURT FOR SARASOTA COUNTY, FLORIDA PROBATE DIVISION
File No. 2012CP003345NC
IN RE: ESTATE OF GEORGIA BROWN Deceased.

The administration of the estate of Georgia Brown, deceased, whose date of death was July 23, 2012, is pending in the Circuit Court for Sarasota County, Florida, Probate Division, the address of which is PO Box 3079, Sarasota, Florida 34230. The names and addresses of the personal representative and the personal representative's attorney are set forth below.

All creditors of the decedent and other persons having claims or demands against decedent's estate on whom a copy of this notice is required to be served must file their claims with this court WITHIN THE LATER OF 3 MONTHS AFTER THE TIME OF THE FIRST PUBLICATION OF THIS NOTICE OR 30 DAYS AFTER THE DATE OF SERVICE OF A COPY OF THIS NOTICE ON THEM.

All other creditors of the decedent and other persons having claims or demands against decedent's estate must file their claims with this court WITHIN 3 MONTHS AFTER THE DATE OF THE FIRST PUBLICATION OF THIS NOTICE.

ALL CLAIMS NOT FILED WITHIN THE TIME PERIODS SET FORTH IN SECTION 733.702 OF THE FLORIDA PROBATE CODE WILL BE FOREVER BARRED.

NOTWITHSTANDING THE TIME PERIODS SET FORTH ABOVE, ANY CLAIM FILED TWO (2) YEARS OR MORE AFTER THE DECEDENT'S DATE OF DEATH IS BARRED.

The date of first publication of this notice is October 12, 2012.

Personal Representative:
Merrill E. Brown
c/o David W. Payne, Esq.

Attorney for Personal Representative:
David W. Payne, Esq.
Florida Bar Number: 0958530
PAYNE LAW GROUP, P.A.
240 S Pineapple Ave, Suite 401
Sarasota, FL 34236
Telephone: (941) 487 2800
Fax: (941) 487 2801
E-Mail: dpayne@lawnav.com
Secondary E-Mail:
mlobo@lawnav.com
October 12, 19, 2012 12-3908S

FIRST INSERTION

NOTICE TO CREDITORS IN THE CIRCUIT COURT FOR SARASOTA COUNTY, FLORIDA PROBATE DIVISION
File No. 2012 NC 3400 NC
IN RE: ESTATE OF LOUISE A. MARROW, Deceased.

The administration of the estate of LOUISE A. MARROW, deceased, whose date of death was August 16, 2012, is pending in the Circuit Court for Sarasota County, Florida, Probate Division, the address of which is 2000 Main Street, Sarasota, FL 34237. The names and addresses of the personal representative and the personal representative's attorney are set forth below.

All creditors of the decedent and other persons having claims or demands against decedent's estate on whom a copy of this notice is required to be served must file their claims with this court WITHIN THE LATER OF 3 MONTHS AFTER THE TIME OF THE FIRST PUBLICATION OF THIS NOTICE OR 30 DAYS AFTER THE DATE OF SERVICE OF A COPY OF THIS NOTICE ON THEM.

All other creditors of the decedent and other persons having claims or demands against decedent's estate must file their claims with this court WITHIN 3 MONTHS AFTER THE DATE OF THE FIRST PUBLICATION OF THIS NOTICE.

ALL CLAIMS NOT FILED WITHIN THE TIME PERIODS SET FORTH IN SECTION 733.702 OF THE FLORIDA PROBATE CODE WILL BE FOREVER BARRED.

NOTWITHSTANDING THE TIME PERIOD SET FORTH ABOVE, ANY CLAIM FILED TWO (2) YEARS OR MORE AFTER THE DECEDENT'S DATE OF DEATH IS BARRED.

The date of first publication of this notice is October 12, 2012.

Personal Representative:
JANE FRASER

210 Laurel Drive
Sedro Woolley, WA 98284-1231
JEFFREY T. TROIANO
Florida Bar No. 0031557
WILLIAMS PARKER HARRISON
DIETZ & GETZEN
200 S. Orange Ave.
Sarasota, FL 34236
Telephone: 941-366-4800
Designation of Email
Addresses for service:
Primary:
jtroiано@williams-parker.com
Secondary:
kmartins@williams-parker.com
October 12, 19, 2012 12-3910S

FIRST INSERTION
NOTICE TO CREDITORS
IN THE CIRCUIT COURT FOR
SARASOTA COUNTY, FLORIDA
PROBATE DIVISION
File No. 2012-CP-003670-NC
IN RE: ESTATE OF
ANNA-MARY B. MILLER
Deceased.
The administration of the estate of ANNA-MARY B. MILLER, deceased, whose date of death was June 15, 2012, and whose Social Security number is 564-42-8902; is pending in the Circuit Court for Sarasota County, Florida, Probate Division; File Number: 2012-CP-003670-NC; the address of which is 2000 Main Street, Sarasota, Florida 34237. The names and addresses of the Personal Representative and the Personal Representative's attorney are set forth below.
All creditors of the decedent and other persons having claims or demands against decedent's estate on whom a copy of this notice is required to be served must file their claims with this court WITHIN THE LATER OF 3 MONTHS AFTER THE TIME OF THE FIRST PUBLICATION OF THIS NOTICE OR 30 DAYS AFTER THE DATE OF SERVICE OF A COPY OF THIS NOTICE ON THEM.
All other creditors of the decedent and other persons who have claims or demands against decedent's estate must file their claims with this court WITHIN THREE (3) MONTHS AFTER THE DATE OF THE FIRST PUBLICATION OF THIS NOTICE.
ALL CLAIMS NOT FILED WITHIN THE TIME PERIODS SET FORTH IN SECTION 733.702 OF THE FLORIDA PROBATE CODE WILL BE FOREVER BARRED.
NOTWITHSTANDING THE TIME PERIODS SET FORTH ABOVE, ANY CLAIM FILED TWO (2) YEARS OR MORE AFTER THE DECEDENT'S DATE OF DEATH IS BARRED.
The date of first publication of this notice is October 12, 2012.
Personal Representative
ROBERT J. MILLER
7830 S. Leewynn Drive
Sarasota, FL 34240
Attorney for Personal Representative
Vicki M. Wilson
VICKI M. WILSON, P.A.
2075 Fruitville Rd., Ste. 100
Sarasota, Florida 34237
Telephone: (941) 951-1133
Florida Bar Number: 0175455
October 12, 19, 2012 12-3974S

FIRST INSERTION
NOTICE TO CREDITORS
IN THE CIRCUIT COURT FOR
SARASOTA COUNTY, FLORIDA
PROBATE DIVISION
File No. 2012 CP 001631 NC
IN RE: ESTATE OF
FRANK MARCUS BUNN JR.
Deceased.
The administration of the estate of FRANK MARCUS BUNN, JR., deceased, whose date of death was April 16, 2011, is pending in the Circuit Court for Sarasota County, Florida, Probate Division, the address of which is 2000 Main Street, Sarasota, FL 34237. The names and addresses of the personal representative and the personal representative's attorney are set forth below.
All creditors of the decedent and other persons having claims or demands against decedent's estate on whom a copy of this notice is required to be served must file their claims with this court WITHIN THE LATER OF 3 MONTHS AFTER THE TIME OF THE FIRST PUBLICATION OF THIS NOTICE OR 30 DAYS AFTER THE DATE OF SERVICE OF A COPY OF THIS NOTICE ON THEM.
All other creditors of the decedent and other persons having claims or demands against decedent's estate must file their claims with this court WITHIN 3 MONTHS AFTER THE DATE OF THE FIRST PUBLICATION OF THIS NOTICE.
ALL CLAIMS NOT FILED WITHIN THE TIME PERIODS SET FORTH IN SECTION 733.702 OF THE FLORIDA PROBATE CODE WILL BE FOREVER BARRED.
NOTWITHSTANDING THE TIME PERIOD SET FORTH ABOVE, ANY CLAIM FILED TWO (2) YEARS OR MORE AFTER THE DECEDENT'S DATE OF DEATH IS BARRED.
The date of first publication of this notice is October 12, 2012.
Personal Representative:
Janice Emanuel Bunn,
Personal Representative
5583 Jody Avenue
North Port, FL 34288
Attorney for Personal Representative:
Ann S. Johnson, Esquire
ANN S. JOHNSON, P.A.
Florida Bar No. 0936561
5824 Lakewood Ranch Blvd.
Sarasota, FL 34240
Email: ajohnson@asjlaw.com
Telephone: (941) 361-1106
Facsimile: (941) 361-1163
October 12, 19, 2012 12-3982S

FIRST INSERTION
NOTICE TO CREDITORS
IN THE CIRCUIT COURT FOR
SARASOTA COUNTY, FLORIDA
PROBATE DIVISION
File No. 2012CP 3737 NC
IN RE: ESTATE OF
KATHRYN M. WEISER,
Deceased.
The administration of the estate of KATHRYN M. WEISER, deceased, whose date of death was September 8, 2012; File Number 2012CP 3737 NC, is pending in the Circuit Court for Sarasota County, Florida, Probate Division, the address of which is P.O. Box 3079, Sarasota, FL 34230. The names and addresses of the personal representative and the personal representative's attorney are set forth below.
All creditors of the decedent and other persons having claims or demands against decedent's estate on whom a copy of this notice is required to be served must file their claims with this court WITHIN THE LATER OF 3 MONTHS AFTER THE TIME OF THE FIRST PUBLICATION OF THIS NOTICE OR 30 DAYS AFTER THE DATE OF SERVICE OF A COPY OF THIS NOTICE ON THEM.
All other creditors of the decedent and other persons having claims or demands against decedent's estate must file their claims with this court WITHIN 3 MONTHS AFTER THE DATE OF THE FIRST PUBLICATION OF THIS NOTICE.
ALL CLAIMS NOT FILED WITHIN THE TIME PERIODS SET FORTH IN SECTION 733.702 OF THE FLORIDA PROBATE CODE WILL BE FOREVER BARRED.
NOTWITHSTANDING THE TIME PERIOD SET FORTH ABOVE, ANY CLAIM FILED TWO (2) YEARS OR MORE AFTER THE DECEDENT'S DATE OF DEATH IS BARRED.
The date of first publication of this notice is October 12, 2012.
JANET HOLCOMB
Personal Representative
3748 Helene Street
Sarasota, FL 34233
H. GREG LEE
Attorney for Personal Representative
Email: hglee@hgreglee.com
Florida Bar No. 351301
H. GREG LEE, P.A.
2014 Fourth Street
Sarasota, Florida 34237
Telephone: (941) 954-0067
Facsimile: (941) 365-1492
October 12, 19, 2012 12-3969S

FIRST INSERTION
NOTICE TO CREDITORS
IN THE CIRCUIT COURT FOR
SARASOTA COUNTY, FLORIDA
PROBATE DIVISION
File No. 2012CP003683NC
IN RE: ESTATE OF
ELAINE C. AMUNDSON
Deceased.
The administration of the estate of Elaine C. Amundson, deceased, whose date of death was June 22, 2012, is pending in the Circuit Court for Sarasota County, Florida, Probate Division, the address of which is Post Office Box 3079, Sarasota, FL 34230-3079. The names and addresses of the personal representatives and the personal representatives' attorney are set forth below.
All creditors of the decedent and other persons having claims or demands against decedent's estate on whom a copy of this notice is required to be served must file their claims with this court WITHIN THE LATER OF 3 MONTHS AFTER THE TIME OF THE FIRST PUBLICATION OF THIS NOTICE OR 30 DAYS AFTER THE DATE OF SERVICE OF A COPY OF THIS NOTICE ON THEM.
All other creditors of the decedent and other persons having claims or demands against decedent's estate must file their claims with this court WITHIN 3 MONTHS AFTER THE DATE OF THE FIRST PUBLICATION OF THIS NOTICE.
ALL CLAIMS NOT FILED WITHIN THE TIME PERIODS SET FORTH IN SECTION 733.702 OF THE FLORIDA PROBATE CODE WILL BE FOREVER BARRED.
NOTWITHSTANDING THE TIME PERIODS SET FORTH ABOVE, ANY CLAIM FILED TWO (2) YEARS OR MORE AFTER THE DECEDENT'S DATE OF DEATH IS BARRED.
The date of first publication of this notice is October 12, 2012.
Personal Representatives:
David W. Amundson
313 E. Sussex Avenue
Missoula, Montana 59801
Craig A. Amundson
202 W. Arrowhead Road
Duluth, MN 55803
Attorney for Personal Representatives:
BRIAN Y. MILLER
Florida Bar Number: 0152050
2477 Stickney Point Road, Suite 107B
Sarasota, FL 34231
Telephone: (941) 923-3453
Fax: (941) 923-0341
E-Mail: bymillerpa@aol.com
October 12, 19, 2012 12-3972S

FIRST INSERTION
NOTICE TO CREDITORS
IN THE CIRCUIT COURT FOR
SARASOTA COUNTY, FLORIDA
PROBATE DIVISION
File No. 2012-CP-003733-NC
IN RE: ESTATE OF
PHYLLIS R. WIER
Deceased.
The administration of the estate of PHYLLIS R. WIER, deceased, whose date of death was September 6, 2012, is pending in the Circuit Court for SARASOTA County, Florida, Probate Division, the address of which is P.O. Box 3079, Sarasota, Florida 34230-3079. The names and addresses of the personal representative and the personal representative's attorney are set forth below.
All creditors of the decedent and other persons having claims or demands against decedent's estate on whom a copy of this notice is required to be served must file their claims with this court WITHIN THE LATER OF 3 MONTHS AFTER THE TIME OF THE FIRST PUBLICATION OF THIS NOTICE OR 30 DAYS AFTER THE DATE OF SERVICE OF A COPY OF THIS NOTICE ON THEM.
All other creditors of the decedent and other persons having claims or demands against decedent's estate must file their claims with this court WITHIN 3 MONTHS AFTER THE DATE OF THE FIRST PUBLICATION OF THIS NOTICE.
ALL CLAIMS NOT FILED WITHIN THE TIME PERIODS SET FORTH IN SECTION 733.702 OF THE FLORIDA PROBATE CODE WILL BE FOREVER BARRED.
NOTWITHSTANDING THE TIME PERIOD SET FORTH ABOVE, ANY CLAIM FILED TWO (2) YEARS OR MORE AFTER THE DECEDENT'S DATE OF DEATH IS BARRED.
The date of first publication of this notice is October 12, 2012.
Personal Representative:
BRIDGET WREFORD
1849 Briar Creek Court
Sarasota, Florida 34235
Attorney for Personal Representative:
ROBERT P. SCHEB
E-Mail Address:
rscheb@bowmangeorge.com
Florida Bar No. 398519
BOWMAN, GEORGE,
SCHEB & TOALE, P.A.
2750 Ringling Blvd., Suite 3
Sarasota, Florida 34237
Telephone: (941) 366-5510
October 12, 19, 2012 12-3964S

FIRST INSERTION
NOTICE TO CREDITORS
IN THE CIRCUIT COURT FOR
SARASOTA COUNTY, FLORIDA
PROBATE DIVISION
File No. 2012 CP 003702 NC
IN RE: ESTATE OF
MYRNA HERMAN
Deceased.
The administration of the estate of MYRNA HERMAN, deceased, whose date of death was July 1, 2012, is pending in the Circuit Court for Sarasota County, Florida, Probate Division, the address of which is PO Box 3079, Sarasota, Florida 34230. The names and addresses of the personal representatives and the personal representatives' attorney are set forth below.
All creditors of the decedent and other persons having claims or demands against decedent's estate on whom a copy of this notice is required to be served must file their claims with this court WITHIN THE LATER OF 3 MONTHS AFTER THE TIME OF THE FIRST PUBLICATION OF THIS NOTICE OR 30 DAYS AFTER THE DATE OF SERVICE OF A COPY OF THIS NOTICE ON THEM.
All other creditors of the decedent and other persons having claims or demands against decedent's estate must file their claims with this court WITHIN 3 MONTHS AFTER THE DATE OF THE FIRST PUBLICATION OF THIS NOTICE.
ALL CLAIMS NOT FILED WITHIN THE TIME PERIODS SET FORTH IN SECTION 733.702 OF THE FLORIDA PROBATE CODE WILL BE FOREVER BARRED.
NOTWITHSTANDING THE TIME PERIODS SET FORTH ABOVE, ANY CLAIM FILED TWO (2) YEARS OR MORE AFTER THE DECEDENT'S DATE OF DEATH IS BARRED.
The date of first publication of this notice is October 12, 2012.
Personal Representatives:
Milton S. Herman
1945 Gulf of Mexico Dr., #312
Longboat Key, Florida 34228
Attorney for Personal Representatives:
John A. Moran
Attorney for Milton S. Herman
Florida Bar Number: 0718335
DUNLAP & MORAN PA
Post Office Box 3948
Sarasota, FL 34230
Telephone: (941) 366-0115
Fax: (941) 365-4660
E-Mail: jricker@dunlapmoran.com
Secondary E-Mail:
jmassistant@dunlapmoran.com
October 12, 19, 2012 12-3903S

FIRST INSERTION
NOTICE TO CREDITORS
IN THE CIRCUIT COURT FOR
SARASOTA COUNTY, FLORIDA
PROBATE DIVISION
Twelfth Judicial Circuit
File No. 2012 CP 003586 NC
IN RE: ESTATE OF
PAULA BLEYER
Deceased.
The administration of the estate of PAULA BLEYER, deceased, whose date of death was September 7, 2012, and whose social security number was xxx-xx-2716, is pending in the Circuit Court for Sarasota County, Florida, Probate Division, the address of which is 2002 Ringling Blvd., Sarasota, Florida 34237. The names and addresses of the personal representative and the personal representative's attorney are set forth below.
All creditors of the decedent and other persons having claims or demands against decedent's estate on whom a copy of this notice is required to be served must file their claims with this court WITHIN THE LATER OF 3 MONTHS AFTER THE TIME OF THE FIRST PUBLICATION OF THIS NOTICE OR 30 DAYS AFTER THE DATE OF SERVICE OF A COPY OF THIS NOTICE ON THEM.
All other creditors of the decedent and other persons having claims or demands against decedent's estate must file their claims with this court WITHIN 3 MONTHS AFTER THE DATE OF THE FIRST PUBLICATION OF THIS NOTICE.
ALL CLAIMS NOT FILED WITHIN THE TIME PERIODS SET FORTH IN SECTION 733.702 OF THE FLORIDA PROBATE CODE WILL BE FOREVER BARRED.
NOTWITHSTANDING THE TIME PERIOD SET FORTH ABOVE, ANY CLAIM FILED TWO (2) YEARS OR MORE AFTER THE DECEDENT'S DATE OF DEATH IS BARRED.
The date of first publication of this notice is October 12, 2012.
Personal Representative:
E. John Lopez
1819 Main Street, Suite 610
Sarasota, Florida 34236
Attorney for Personal Representative:
E. John Lopez
Primary Email Address:
johnlopez@nhslaw.com
Secondary Email Address:
kkidd@nhslaw.com
Florida Bar No. 0394300
NORTON, HAMMERSLEY,
LOPEZ & SKOKOS, P.A.
1819 Main Street, Suite 610
Sarasota, Florida 34236
Telephone: (941) 954-4691
October 12, 19, 2012 12-3973S

FIRST INSERTION
NOTICE TO CREDITORS
IN THE CIRCUIT COURT FOR
SARASOTA COUNTY, FLORIDA
PROBATE DIVISION
File No. 2012 CP 003647 NC
IN RE: ESTATE OF
BEVERLY SUE ABRELL
Deceased.
The administration of the estate of BEVERLY SUE ABRELL, deceased, whose date of death was June 30, 2012, is pending in the Circuit Court for Sarasota County, Florida, Probate Division, the address of which is PO Box 3079, Sarasota, FL 34230. The names and addresses of the personal representative and the personal representative's attorney are set forth below.
All creditors of the decedent and other persons having claims or demands against decedent's estate on whom a copy of this notice is required to be served must file their claims with this court WITHIN THE LATER OF 3 MONTHS AFTER THE TIME OF THE FIRST PUBLICATION OF THIS NOTICE OR 30 DAYS AFTER THE DATE OF SERVICE OF A COPY OF THIS NOTICE ON THEM.
All other creditors of the decedent and other persons having claims or demands against decedent's estate must file their claims with this court WITHIN 3 MONTHS AFTER THE DATE OF THE FIRST PUBLICATION OF THIS NOTICE.
ALL CLAIMS NOT FILED WITHIN THE TIME PERIODS SET FORTH IN SECTION 733.702 OF THE FLORIDA PROBATE CODE WILL BE FOREVER BARRED.
NOTWITHSTANDING THE TIME PERIODS SET FORTH ABOVE, ANY CLAIM FILED TWO (2) YEARS OR MORE AFTER THE DECEDENT'S DATE OF DEATH IS BARRED.
The date of first publication of this notice is October 12, 2012.
Personal Representative:
David Abrell
c/o Fredric C. Jacobs, Esq.
Bach & Jacobs, P.A.
240 S. Pineapple Avenue, Suite 700
Sarasota, FL 34236
Attorney for Personal Representative:
Fredric C. Jacobs, Esq.
Attorney for David Abrell
Florida Bar Number: 0027969
BACH & JACOBS, P.A.
240 S. Pineapple Avenue, Suite 700
Sarasota, FL 34236
Telephone: (941) 906-1231
Fax: (941) 954-1185
E-Mail: fred@sarosotaelderlaw.com
Secondary E-Mail:
enotice@sarosotaelderlaw.com
October 12, 19, 2012 12-3971S

FIRST INSERTION
NOTICE TO CREDITORS
IN THE CIRCUIT COURT FOR
SARASOTA COUNTY, FLORIDA
PROBATE DIVISION
File No.: 2012 CP 003090 NC
IN RE: ESTATE OF
GWLADYS GWENNETH WAYMAN
a/k/a GWLADYS G. WAYMAN
Deceased.
The administration of the ESTATE OF GWLADYS GWENNETH WAYMAN a/k/a GWLADYS G. WAYMAN, deceased, File No: 2012 CP 003090 NC, whose date of death was June 27, 2012, is pending in the Circuit Court for Sarasota County, Florida, Probate Division, the post office address of which is Clerk of the Court, Attn: Probate, Post Office Box 3079, Sarasota, Florida 34230. The names and addresses of the personal representative and the personal representative's attorney are set forth below.
All creditors of the decedent and other persons having claims or demands against decedent's estate, including unmaturred, contingent or unliquidated claims, on whom a copy of this notice is required to be served must file their claims with this court WITHIN THE LATER OF 3 MONTHS AFTER THE TIME OF THE FIRST PUBLICATION OF THIS NOTICE OR 30 DAYS AFTER THE DATE OF SERVICE OF A COPY OF THIS NOTICE ON THEM.
All other creditors of the decedent and other persons having claims or demands against decedent's estate, including unmaturred, contingent or unliquidated claims, must file their claims with this court WITHIN 3 MONTHS AFTER THE DATE OF THE FIRST PUBLICATION OF THIS NOTICE.
ALL CLAIMS NOT FILED WITHIN THE TIME PERIODS SET FORTH IN SECTION 733.702 OF THE FLORIDA PROBATE CODE WILL BE FOREVER BARRED.
NOTWITHSTANDING THE TIME PERIODS SET FORTH ABOVE, ANY CLAIM FILED TWO (2) YEARS OR MORE AFTER THE DECEDENT'S DATE OF DEATH IS BARRED.
The date of first publication of this notice is October 12, 2012.
Personal Representatives:
KRAIG H. KOACH
c/o KIMBROUGH & KOACH, LLP
727 South Orange Avenue
Sarasota, FL 34236-7741
Attorney for Personal Representatives:
KRAIG H. KOACH, ATTORNEY
KIMBROUGH & KOACH, LLP
727 South Orange Avenue
Sarasota, FL 34236-7741
Telephone: (941) 951-1234
Florida Bar No.: 510830
October 12, 19, 2012 12-3905S

FIRST INSERTION
NOTICE TO CREDITORS
IN THE CIRCUIT COURT FOR
SARASOTA COUNTY, FLORIDA
PROBATE DIVISION
File No. 2012-CP-3553 NC
IN RE: ESTATE OF
NANCY W. DRIEHORST
Deceased.
The administration of the estate of Nancy W. Driehorst, deceased, whose date of death was July 29, 2012, is pending in the Circuit Court for Sarasota County, Florida, Probate Division, the address of which is 2000 Main Street, Sarasota, Florida 34237. The names and addresses of the personal representative and the personal representative's attorney are set forth below.
All creditors of the decedent and other persons having claims or demands against decedent's estate on whom a copy of this notice is required to be served must file their claims with this court WITHIN THE LATER OF 3 MONTHS AFTER THE TIME OF THE FIRST PUBLICATION OF THIS NOTICE OR 30 DAYS AFTER THE DATE OF SERVICE OF A COPY OF THIS NOTICE ON THEM.
All other creditors of the decedent and other persons having claims or demands against decedent's estate, must file their claims with this court WITHIN 3 MONTHS AFTER THE DATE OF THE FIRST PUBLICATION OF THIS NOTICE.
ALL CLAIMS NOT FILED WITHIN THE TIME PERIODS SET FORTH IN SECTION 733.702 OF THE FLORIDA PROBATE CODE WILL BE FOREVER BARRED.
NOTWITHSTANDING THE TIME PERIODS SET FORTH ABOVE, ANY CLAIM FILED TWO (2) YEARS OR MORE AFTER THE DECEDENT'S DATE OF DEATH IS BARRED.
The date of first publication of this notice is October 12, 2012.
Personal Representative:
Security National Trust Co., a national banking association
By: Mark C. Ferrell, President and Chief Executive Officer
1300 Chapline Street
Wheeling, WV 26003
Attorney for Personal Representative:
Ernest H. Hatch
Florida Bar Number: 097091
HENDERSON, FRANKLIN,
STARNES & HOLT, P.A.
1715 Monroe Street
P.O. Box 280
Fort Myers, FL 33902-0280
Telephone: (239) 344-1100
Fax: (239) 344-1200
E-Mail: ernest.hatch@henlaw.com
Secondary E-Mail:
sabrana.guerin@henlaw.com
Secondary E-Mail:
service@henlaw.com
October 12, 19, 2012 12-3904S

FIRST INSERTION
NOTICE TO CREDITORS
IN THE CIRCUIT COURT FOR
SARASOTA COUNTY, FLORIDA
PROBATE DIVISION
File No. 2012-CP-003749 NC
IN RE: ESTATE OF
ALBERT J. VITUCCI
Deceased.
The administration of the estate of ALBERT J. VITUCCI, deceased, whose date of death was August 29, 2012, and the last four digits of whose social security number are 3161, is pending in the Circuit Court for Sarasota County, Florida, Probate Division, the address of which is P.O. Box 3079, Sarasota, FL 34230. The names and addresses of the personal representative and the personal representative's attorney are set forth below.
All creditors of the decedent and other persons having claims or demands against decedent's estate on whom a copy of this notice is required to be served must file their claims with this court WITHIN THE LATER OF 3 MONTHS AFTER THE TIME OF THE FIRST PUBLICATION OF THIS NOTICE OR 30 DAYS AFTER THE DATE OF SERVICE OF A COPY OF THIS NOTICE ON THEM.
All other creditors of the decedent and other persons having claims or demands against decedent's estate must file their claims with this court WITHIN 3 MONTHS AFTER THE DATE OF THE FIRST PUBLICATION OF THIS NOTICE.
ALL CLAIMS NOT FILED WITHIN THE TIME PERIODS SET FORTH IN SECTION 733.702 OF THE FLORIDA PROBATE CODE WILL BE FOREVER BARRED.
NOTWITHSTANDING THE TIME PERIODS SET FORTH ABOVE, ANY CLAIM FILED TWO (2) YEARS OR MORE AFTER THE DECEDENT'S DATE OF DEATH IS BARRED.
The date of first publication of this notice is October 12, 2012.
Personal Representative:
GARY D. VITUCCI
11515 Bayshore Dr.
Seminole, Florida 33772
Attorney for Personal Representative:
SNOWDEN S. MOWRY
Attorney for GARY D. VITUCCI
Florida Bar Number: 0939129
227 Pensacola, Rd.
Venice, Florida 34285
Telephone: (941) 480-0333
Fax: (941) 486-4106
E-Mail: mowrylaw@daystar.net
October 12, 19, 2012 12-3907S

and other persons having claims or demands against decedent's estate must file their claims with this court WITHIN 3 MONTHS AFTER THE DATE OF THE FIRST PUBLICATION OF THIS NOTICE.
ALL CLAIMS NOT FILED WITHIN THE TIME PERIODS SET FORTH IN SECTION 733.702 OF THE FLORIDA PROBATE CODE WILL BE FOREVER BARRED.
NOTWITHSTANDING THE TIME PERIODS SET FORTH ABOVE, ANY CLAIM FILED TWO (2) YEARS OR MORE AFTER THE DECEDENT'S DATE OF DEATH IS BARRED.
The date of first publication of this notice is October 12, 2012.
Personal Representative:
GARY D. VITUCCI
11515 Bayshore Dr.
Seminole, Florida 33772
Attorney for Personal Representative:
SNOWDEN S. MOWRY
Attorney for GARY D. VITUCCI
Florida Bar Number: 0939129
227 Pensacola, Rd.
Venice, Florida 34285
Telephone: (941) 480-0333
Fax: (941) 486-4106
E-Mail: mowrylaw@daystar.net
October 12, 19, 2012 12-3907S

SAVE TIME
Fax your Legal Notice
Sarasota / Manatee Counties 941.954.8530
Hillsborough County 813.221.9403
Pinellas County 727.447.3944
Lee County 239.936.1001
Collier County 239.263.0112
SAVE TIME
Wednesday Noon Deadline
Friday Publication
GULF COAST
Business Review
www.review.net

FIRST INSERTION

NOTICE OF FORECLOSURE SALE IN THE CIRCUIT COURT OF THE 12TH JUDICIAL CIRCUIT, IN AND FOR SARASOTA COUNTY, FLORIDA

CIVIL DIVISION:
CASE NO.: 2010 CA 002249 NC
WELLS FARGO BANK, N.A., AS TRUSTEE FOR THE CERTIFICATEHOLDERS OF BANC OF AMERICA ALTERNATIVE LOAN TRUST 2006-8, MORTGAGE PASS-THROUGH CERTIFICATES, SERIES 2006-8, Plaintiff, vs. EDWARD R. EACHUS; UNKNOWN TENANT(S); IN POSSESSION OF THE SUBJECT PROPERTY, Defendant(s).

NOTICE IS HEREBY GIVEN pursuant to Final Judgment of Foreclosure dated the 24th day of September, 2012, and entered in Case No. 2010 CA 002249 NC, of the Circuit Court of the 12TH Judicial Circuit in and for Sarasota County, Florida, wherein WELLS FARGO BANK, N.A., AS TRUSTEE FOR THE CERTIFICATEHOLDERS OF BANC OF AMERICA ALTERNATIVE LOAN TRUST 2006-8, MORTGAGE PASS-THROUGH CERTIFICATES, SERIES 2006-8 is the Plaintiff and EDWARD R. EACHUS and UNKNOWN TENANT(S) IN POSSESSION OF THE SUBJECT PROPERTY are defendants. The Clerk of this Court shall sell to the highest and best bidder for cash electronically at www.sarasota.realforeclose.com at, 9:00 AM on the 30th day of October, 2012, the following described property as set forth in said Final Judgment, to wit:

LOT 17, BLOCK OF ENGLEWOOD VIEW ACCORDING TO THE PLAT THEREOF, AS RECORDED ON PLAT BOOK 2, PAGE 140, OF THE PUBLIC RECORDS OF SARASOTA COUNTY, FLORIDA

ANY PERSON CLAIMING AN INTEREST IN THE SURPLUS FROM THE SALE, IF ANY, OTHER THAN THE PROPERTY OWNER AS OF THE DATE OF THE LIS PENDENS MUST FILE A CLAIM WITHIN 60 DAYS AFTER THE SALE.

In accordance with the Americans With Disabilities Act, persons needing a reasonable accommodation to participate in this proceeding should contact the Clerk of the Circuit Court no later than seven business days prior to the proceeding at the Sarasota County Courthouse. Telephone 941-861-7425 (Sarasota and Venice) or 1-800-955-8770 via Florida Relay Service.

Dated this 10th day of October, 2012.
By: Lucetta Pierre-Louis, Esq.
Bar Number: 86807

Submitted by:
LAW OFFICES OF MARSHALL C. WATSON, P.A. 1800 NW 49th Street, Suite 120 Fort Lauderdale, Florida 33309 Telephone: (954) 453-0365 Facsimile: (954) 771-6052 Toll Free: 1-800-441-2438 DESIGNATED PRIMARY E-MAIL FOR SERVICE PURSUANT TO FLA. R. JUD. ADMIN 2.516 eservice@marshallwatson.com 10-04601
October 12, 19, 2012 12-3978S

FIRST INSERTION

NOTICE OF FORECLOSURE SALE IN THE CIRCUIT COURT OF THE 12TH JUDICIAL CIRCUIT, IN AND FOR SARASOTA COUNTY, FLORIDA

CIVIL DIVISION:
CASE NO.: 2009 CA 012706 NC
SUNTRUST MORTGAGE INC, Plaintiff, vs. WYATT G. WOLF A/K/A WYATT WOLF; MORTGAGE ELECTRONIC REGISTRATION SYSTEMS INCORPORATED AS NOMINEE FOR SUNTRUST MORTGAGE, INC.; VIRGINIA L. WOLF; UNKNOWN TENANT(S); IN POSSESSION OF THE SUBJECT PROPERTY, Defendant(s).

NOTICE IS HEREBY GIVEN pursuant to Final Judgment of Foreclosure dated the 24th day of September, 2012, and entered in Case No. 2009 CA 012706 NC, of the Circuit Court of the 12TH Judicial Circuit in and for Sarasota County, Florida, wherein SUNTRUST MORTGAGE, INC. is the Plaintiff and WYATT G. WOLF A/K/A WYATT WOLF; MORTGAGE ELECTRONIC REGISTRATION SYSTEMS INCORPORATED AS NOMINEE FOR SUNTRUST MORTGAGE, INC.; VIRGINIA L. WOLF; UNKNOWN TENANT(S); IN POSSESSION OF THE SUBJECT PROPERTY are defendants. The Clerk of this Court shall sell to the highest and best bidder for cash electronically at www.sarasota.realforeclose.com at, 9:00 AM on the 30th day of October, 2012, the following described property as set forth in said Final Judgment, to wit:

LOTS 1 AND 2, BLOCK 1329, 26TH ADDITION TO PORT CHARLOTTE SUBDIVISION, ACCORDING TO THE PLAT THEREOF RECORDED IN PLAT BOOK 15, PAGE 3, OF THE PUBLIC RECORDS OF SARASOTA COUNTY, FLORIDA.

ANY PERSON CLAIMING AN INTEREST IN THE SURPLUS FROM THE SALE, IF ANY, OTHER THAN THE PROPERTY OWNER AS OF THE DATE OF THE LIS PENDENS MUST FILE A CLAIM WITHIN 60 DAYS AFTER THE SALE.

In accordance with the Americans With Disabilities Act, persons needing a reasonable accommodation to participate in this proceeding should contact the Clerk of the Circuit Court no later than seven business days prior to the proceeding at the Sarasota County Courthouse. Telephone 941-861-7425 (Sarasota and Venice) or 1-800-955-8770 via Florida Relay Service.

Dated this 10th day of October, 2012.
By: Jimmy Edwards, Esq.
Bar Number: 81855

Submitted by:
LAW OFFICES OF MARSHALL C. WATSON, P.A. 1800 NW 49th Street, Suite 120 Fort Lauderdale, Florida 33309 Telephone: (954) 453-0365 Facsimile: (954) 771-6052 Toll Free: 1-800-441-2438 DESIGNATED PRIMARY E-MAIL FOR SERVICE PURSUANT TO FLA. R. JUD. ADMIN 2.516 eservice@marshallwatson.com 09-37792
October 12, 19, 2012 12-3977S

FIRST INSERTION

NOTICE OF SALE IN THE CIRCUIT COURT OF THE TWELFTH JUDICIAL CIRCUIT IN AND FOR SARASOTA COUNTY, FLORIDA

CASE NO.: 2009-CA-016920 NC
SEC.: A
CITIMORTGAGE, INC. Plaintiff, vs. FRANCOISE CROTEAU; PAUL CROTEAU; ANY AND ALL UNKNOWN PARTIES CLAIMING BY, THROUGH, UNDER, AND AGAINST THE HEREIN NAMED INDIVIDUAL DEFENDANT(S) WHO ARE NOT KNOWN TO BE DEAD OR ALIVE, WHETHER SAID UNKNOWN PARTIES MAY CLAIM AN INTEREST AS SPOUSES, HEIRS, DEVISEES, GRANTEES, OR OTHER CLAIMANTS; Defendant(s).

NOTICE IS HEREBY GIVEN pursuant to an Order of Final Summary Judgment of Foreclosure dated September 24, 2012, entered in Civil Case No. 2009-CA-016920 NC of the Circuit Court of the Twelfth Judicial Circuit in and for Sarasota County, Florida, wherein the Clerk of the Circuit Court will sell to the highest bidder for cash on 30th day of October, 2012, at 9:00 a.m. online at the website: https://www.sarasota.realforeclose.com, relative to the following described property as set forth in the Final Judgment, to wit:

LOT 20, BLOCK 1565, OF 32ND ADDITION TO PORT CHARLOTTE SUBDIVISION, A SUBDIVISION ACCORDING TO THE PLAT THEREOF, AS RECORDED IN PLAT BOOK 15, PAGES 16, 16A THROUGH 16L, INCLUSIVE, OF THE PUBLIC RECORDS OF SARASOTA COUNTY, FLORIDA.

Any person claiming an interest in the surplus from the sale, if any, other than the property owner as of the date of the Lis Pendens must file a claim within 60 days after the sale.

This is an attempt to collect a debt and any information obtained may be used for that purpose.

In accordance with the Americans With Disabilities Act, persons needing a reasonable accommodation to participate in this proceeding should contact the Clerk of the Circuit Court no later than seven business days prior to the proceeding at the Sarasota County Courthouse. Telephone 941-861-7425 (Sarasota and Venice) or 1-800-955-8770 via Florida Relay Service.

MORRIS|HARDWICK| SCHNEIDER, LLC
By: Susan Sparks, Esq.
FBN: 33626
9409 Philadelphia Road
Baltimore, Maryland 21237
MORRIS|HARDWICK|SCHNEIDER
5110 Eisenhower Blvd., Suite 120
Tampa, Florida 33634
Toll Free: 1-866-503-4930
MHSinbox@closingsource.net
File No.: FL-97002113-09
October 12, 19, 2012 12-3970S

FIRST INSERTION

NOTICE OF FORECLOSURE SALE IN THE CIRCUIT COURT OF THE 12TH JUDICIAL CIRCUIT, IN AND FOR SARASOTA COUNTY, FLORIDA

CIVIL DIVISION:
CASE NO.: 2010 CA 006744 NC
SUNTRUST MORTGAGE INC, Plaintiff, vs. SHEILA INGRAM A/K/A SHEILA M INGRAM; FIFTH THIRD BANK; LAWRENCE BORELLI; UNKNOWN TENANT(S); IN POSSESSION OF THE SUBJECT PROPERTY, Defendant(s).

NOTICE IS HEREBY GIVEN pursuant to Final Judgment of Foreclosure dated the 24th day of September, 2012, and entered in Case No. 2010 CA 006744 NC, of the Circuit Court of the 12TH Judicial Circuit in and for Sarasota County, Florida, wherein NATIONSTAR MORTGAGE, LLC. is the Plaintiff and SHEILA INGRAM A/K/A SHEILA M INGRAM; FIFTH THIRD BANK; LAWRENCE BORELLI; UNKNOWN TENANT(S); IN POSSESSION OF THE SUBJECT PROPERTY are defendants. The Clerk of this Court shall sell to the highest and best bidder for cash electronically at www.sarasota.realforeclose.com at, 9:00 AM on the 30th day of October, 2012, the following described property as set forth in said Final Judgment, to wit:

LOT 24 AND THE SOUTH ONE HALF OF LOT 23 BLOCK F ASHWORTH PARK ACCORDING TO THE PLAT THEREOF RECORDED IN PLAT BOOK 2 PAGE 174 OF THE PUBLIC RECORDS OF SARASOTA COUNTY FLORIDA.

ANY PERSON CLAIMING AN INTEREST IN THE SURPLUS FROM THE SALE, IF ANY, OTHER THAN THE PROPERTY OWNER AS OF THE DATE OF THE LIS PENDENS MUST FILE A CLAIM WITHIN 60 DAYS AFTER THE SALE.

In accordance with the Americans With Disabilities Act, persons needing a reasonable accommodation to participate in this proceeding should contact the Clerk of the Circuit Court no later than seven business days prior to the proceeding at the Sarasota County Courthouse. Telephone 941-861-7425 (Sarasota and Venice) or 1-800-955-8770 via Florida Relay Service.

Dated this 10 day of October, 2012.
By: Jimmy Edwards, Esq.
Bar Number: 81855

Submitted by:
LAW OFFICES OF MARSHALL C. WATSON, P.A. 1800 NW 49th Street, Suite 120 Fort Lauderdale, Florida 33309 Telephone: (954) 453-0365 Facsimile: (954) 771-6052 Toll Free: 1-800-441-2438 DESIGNATED PRIMARY E-MAIL FOR SERVICE PURSUANT TO FLA. R. JUD. ADMIN 2.516 eservice@marshallwatson.com 10-19565
October 12, 19, 2012 12-3976S

FIRST INSERTION

RE-NOTICE OF FORECLOSURE SALE IN THE CIRCUIT COURT OF THE 12TH JUDICIAL CIRCUIT, IN AND FOR SARASOTA COUNTY, FLORIDA

CIVIL DIVISION:
CASE NO.: 2008 CA 001454 SC
COUNTRYWIDE HOME LOANS, INC., Plaintiff, vs. BONNIE VONDECK; UNKNOWN SPOUSE OF BONNIE VONDECK; JOHN DOE; JANE DOE AS UNKNOWN TENANT(S) IN POSSESSION OF THE SUBJECT PROPERTY, Defendant(s).

NOTICE IS HEREBY GIVEN pursuant to an Order Resetting Foreclosure Sale dated the 1st day of August, 2012, and entered in Case No. 2008 CA 001454 SC, of the Circuit Court of the 12TH Judicial Circuit in and for Sarasota County, Florida, wherein BANK OF AMERICA, N.A., SUCCESSOR BY MERGER TO BAC HOME LOANS SERVICING, LP FKA COUNTRYWIDE HOME LOANS SERVICING, LP is the Plaintiff and BONNIE VONDECK; UNKNOWN TENANT(S) IN POSSESSION OF THE SUBJECT PROPERTY are defendants. The Clerk of this Court shall sell to the highest and best bidder for cash electronically at www.sarasota.realforeclose.com at, 9:00 AM on the 30th day of October, 2012, the following described property as set forth in said Final Judgment, to wit:

LOT 4, BLOCK 2612, 52ND AD-

FIRST INSERTION

NOTICE OF FORECLOSURE SALE IN THE CIRCUIT COURT OF THE 12TH JUDICIAL CIRCUIT, IN AND FOR SARASOTA COUNTY, FLORIDA

CIVIL DIVISION:
CASE NO.: 2010 CA 008994 NC
BAC HOME LOANS SERVICING, LP FKA COUNTRYWIDE HOME LOANS SERVICING, LP, Plaintiff, vs. JAMES A. BARGER A/K/A JAMES ALAN BARGER; ARROW FINANCIAL SERVICES, LLC; UNKNOWN SPOUSE OF JAMES A. BARGER A/K/A JAMES ALAN BARGER; UNKNOWN TENANT(S); IN POSSESSION OF THE SUBJECT PROPERTY, Defendant(s).

NOTICE IS HEREBY GIVEN pursuant to Final Judgment of Foreclosure dated the 24th day of September, 2012, and entered in Case No. 2010 CA 008994 NC, of the Circuit Court of the 12TH Judicial Circuit in and for Sarasota County, Florida, wherein BANK OF AMERICA, N.A., AS SUCCESSOR BY MERGER TO BAC HOME LOANS SERVICING, LP FKA COUNTRYWIDE HOME LOANS SERVICING, LP is the Plaintiff and JAMES A. BARGER A/K/A JAMES ALAN BARGER; ARROW FINANCIAL SERVICES, LLC; UNKNOWN TENANT(S); IN POSSESSION OF THE SUBJECT PROPERTY are defendants. The Clerk of this Court shall sell to the highest and best bidder for cash electronically at www.sarasota.realforeclose.com at, 9:00 AM on the 30th day of October, 2012, the following described property as set forth in said

FIRST INSERTION

DITION TO PORT CHARLOTTE SUBDIVISION, ACCORDING TO THE PLAT THEREOF RECORDED IN PLAT BOOK 21, PAGE 13, OF THE PUBLIC RECORDS OF SARASOTA COUNTY, FLORIDA..

ANY PERSON CLAIMING AN INTEREST IN THE SURPLUS FROM THE SALE, IF ANY, OTHER THAN THE PROPERTY OWNER AS OF THE DATE OF THE LIS PENDENS MUST FILE A CLAIM WITHIN 60 DAYS AFTER THE SALE.

In accordance with the Americans With Disabilities Act, persons needing a reasonable accommodation to participate in this proceeding should contact the Clerk of the Circuit Court no later than seven business days prior to the proceeding at the Sarasota County Courthouse. Telephone 941-861-7425 (Sarasota and Venice) or 1-800-955-8770 via Florida Relay Service.

Dated this 10 day of October, 2012.
By: Marjorie Levine, Esq.
Bar Number: 96413

Submitted by:
LAW OFFICES OF MARSHALL C. WATSON, P.A. 1800 NW 49th Street, Suite 120 Fort Lauderdale, Florida 33309 Telephone: (954) 453-0365 Facsimile: (954) 771-6052 Toll Free: 1-800-441-2438 DESIGNATED PRIMARY E-MAIL FOR SERVICE PURSUANT TO FLA. R. JUD. ADMIN 2.516 eservice@marshallwatson.com 07-28026
October 12, 19, 2012 12-3980S

FIRST INSERTION

Final Judgment, to wit:
LOT 765, KENSINGTON PARK, UNIT 6, ACCORDING TO THE PLAT THEREOF, RECORDED IN PLAT BOOK 12, PAGES 17 AND 17A, OF THE PUBLIC RECORDS OF SARASOTA COUNTY, FLORIDA.

ANY PERSON CLAIMING AN INTEREST IN THE SURPLUS FROM THE SALE, IF ANY, OTHER THAN THE PROPERTY OWNER AS OF THE DATE OF THE LIS PENDENS MUST FILE A CLAIM WITHIN 60 DAYS AFTER THE SALE.

In accordance with the Americans With Disabilities Act, persons needing a reasonable accommodation to participate in this proceeding should contact the Clerk of the Circuit Court no later than seven business days prior to the proceeding at the Sarasota County Courthouse. Telephone 941-861-7425 (Sarasota and Venice) or 1-800-955-8770 via Florida Relay Service.

Dated this 10 day of October, 2012.
By: Lucetta Pierre-Louis, Esq.
Bar Number: 86807

Submitted by:
LAW OFFICES OF MARSHALL C. WATSON, P.A. 1800 NW 49th Street, Suite 120 Fort Lauderdale, Florida 33309 Telephone: (954) 453-0365 Facsimile: (954) 771-6052 Toll Free: 1-800-441-2438 DESIGNATED PRIMARY E-MAIL FOR SERVICE PURSUANT TO FLA. R. JUD. ADMIN 2.516 eservice@marshallwatson.com 09-15231
October 12, 19, 2012 12-3975S

FIRST INSERTION

NOTICE OF FORECLOSURE SALE IN THE CIRCUIT COURT OF THE TWELFTH JUDICIAL CIRCUIT, IN AND FOR SARASOTA COUNTY, FLORIDA

CASE NO. 2010 CA 009846 NC
BAC HOME LOANS SERVICING, LP FKA COUNTRYWIDE HOME LOANS SERVICING, LP, Plaintiff, vs. EDWARD C. SYLVESTER, ET AL. Defendants

NOTICE IS HEREBY GIVEN pursuant to a Final Judgment of Foreclosure dated October 8, 2012, and entered in Case No. 2010 CA 009846 NC, of the Circuit Court of the Twelfth Judicial Circuit in and for SARASOTA County, Florida. BANK OF AMERICA, N.A., SUCCESSOR BY MERGER TO BAC HOME LOANS SERVICING, LP FKA COUNTRYWIDE HOME LOANS SERVICING LP (hereafter "Plaintiff"), is Plaintiff and EDWARD C. SYLVESTER; ; UNKNOWN SPOUSE OF EDWARD C. SYLVESTER, are defendants. I will sell to the highest and best bidder for cash via the Internet at www.sarasota.realforeclose.com, at 9:00 a.m., on the _9th_ day of _November_, 2012, the following described property as set forth in said Final Judgment, to wit:

LOT 2, BLOCK I, HIGHLAND PINES, BEING A SUBDIVISION

FIRST INSERTION

OF LOTS 76, 77, 78, 79, 85 AND 86 OF THE PLAT OF INDIAN BEACH SUBDIVISION, AS PER PLAT THEREOF, RECORDED IN PLAT BOOK 1, PAGE 130, OF THE PUBLIC RECORDS OF SARASOTA COUNTY, FLORIDA.

Any person claiming an interest in the surplus from the sale, if any, other than the property owner as of the date of the Lis Pendens must file a claim within 60 days after the sale.

In accordance with the Americans With Disabilities Act, persons needing a reasonable accommodation to participate in this proceeding should contact the Clerk of the Circuit Court no later than seven business days prior to the proceeding at the Sarasota County Courthouse. Telephone 941-861-7425 (Sarasota and Venice) or 1-800-955-8770 via Florida Relay Service.

KAREN RUSHING
CLERK OF THE CIRCUIT COURT
BY _____
As Deputy Clerk
VAN NESS LAW FIRM, P.A.
1239 E. Newport Center Drive
Suite #110
Deerfield Beach, Florida 33442
Phone (954) 571-2031
Fax (954) 571-2033
FN10373-10BA/ee
October 12, 19, 2012 12-3961S

FIRST INSERTION

RE-NOTICE OF FORECLOSURE SALE IN THE CIRCUIT COURT OF THE 12TH JUDICIAL CIRCUIT, IN AND FOR SARASOTA COUNTY, FLORIDA

CIVIL DIVISION:
CASE NO.: 2008 CA 016562 NC
DEUTSCHE BANK NATIONAL TRUST COMPANY, AS TRUSTEE FOR FIRST FRANKLIN MORTGAGE LOAN TRUST 2006-FF16, ASSET-BACKED CERTIFICATES, SERIES 2006-FF16., Plaintiff, vs. MIKHAIL V. KORNEYEV A/K/A MIKHAIL KORNEYEV; VILLAGIO CONDOMINIUM ASSOCIATION, INC.; OLGA KORNEYEVA; UNKNOWN TENANT(S); IN POSSESSION OF THE SUBJECT PROPERTY, Defendant(s).

NOTICE IS HEREBY GIVEN pursuant to an Order Resetting Foreclosure Sale dated the 31st day of July, 2012, and entered in Case No. 2008 CA 016562 NC, of the Circuit Court of the 12TH Judicial Circuit in and for Sarasota County, Florida, wherein DEUTSCHE BANK NATIONAL TRUST COMPANY, AS TRUSTEE FOR FIRST FRANKLIN MORTGAGE LOAN TRUST 2006-FF16, ASSET-BACKED CERTIFICATES, SERIES 2006-FF16. is the Plaintiff and MIKHAIL V. KORNEYEV A/K/A MIKHAIL KORNEYEV, VILLAGIO CONDOMINIUM ASSOCIATION, INC., OLGA KORNEYEVA and UNKNOWN TENANT(S) IN POSSESSION OF THE SUBJECT PROPERTY are defendants. The Clerk of this Court shall sell to the highest and best bidder for cash electronically at www.sarasota.realforeclose.com at, 9:00 AM on the 30th day of October, 2012, the following described property as set forth in

FIRST INSERTION

said Final Judgment, to wit:
UNIT 206, BUILDING 3, VILLAGIO, A CONDOMINIUM, ACCORDING TO THE DECLARATION OF CONDOMINIUM RECORDED IN OFFICIAL RECORDS INSTRUMENT NO. 2003257048, AND AMENDMENTS THERETO, OF THE PUBLIC RECORDS OF SARASOTA COUNTY, FLORIDA. AS AMENDED, TOGETHER WITH AN UNDIVIDED INTEREST IN THE COMMON ELEMENTS APPURTENANT THERETO

ANY PERSON CLAIMING AN INTEREST IN THE SURPLUS FROM THE SALE, IF ANY, OTHER THAN THE PROPERTY OWNER AS OF THE DATE OF THE LIS PENDENS MUST FILE A CLAIM WITHIN 60 DAYS AFTER THE SALE.

In accordance with the Americans With Disabilities Act, persons needing a reasonable accommodation to participate in this proceeding should contact the Clerk of the Circuit Court no later than seven business days prior to the proceeding at the Sarasota County Courthouse. Telephone 941-861-7425 (Sarasota and Venice) or 1-800-955-8770 via Florida Relay Service.

Dated this 10 day of October, 2012.
By: Lucetta Pierre-Louis, Esq.
Bar Number: 86807

Submitted by:
LAW OFFICES OF MARSHALL C. WATSON, P.A. 1800 NW 49th Street, Suite 120 Fort Lauderdale, Florida 33309 Telephone: (954) 453-0365 Facsimile: (954) 771-6052 Toll Free: 1-800-441-2438 DESIGNATED PRIMARY E-MAIL FOR SERVICE PURSUANT TO FLA. R. JUD. ADMIN 2.516 eservice@marshallwatson.com 08-53550
October 12, 19, 2012 12-3981S

FIRST INSERTION

RE-NOTICE OF FORECLOSURE SALE IN THE CIRCUIT COURT OF THE 12TH JUDICIAL CIRCUIT, IN AND FOR SARASOTA COUNTY, FLORIDA

CIVIL DIVISION:
CASE NO.: 2008 CA 013582 NC
THE BANK OF NEW YORK AS SUCCESSOR IN INTEREST TO JPMORGAN CHASE BANK, N.A., AS TRUSTEE FOR THE HOLDERS OF SAMI II 2006-AR6, MORTGAGE PASS-THROUGH CERTIFICATES, SERIES 2006-AR6, Plaintiff, vs. CARSTEN RUEFFER; NATIONAL CITY BANK; UNKNOWN SPOUSE OF CARSTEN RUEFFER; JOHN DOE; JANE DOE; AS UNKNOWN TENANT(S) IN POSSESSION OF THE SUBJECT PROPERTY, Defendant(s).

NOTICE IS HEREBY GIVEN pursuant to an Order Resetting Foreclosure Sale dated the 31st day of July, 2012, and entered in Case No. 2008 CA 013582 NC, of the Circuit Court of the 12TH Judicial Circuit in and for Sarasota County, Florida, wherein THE BANK OF NEW YORK AS SUCCESSOR IN INTEREST TO JPMORGAN CHASE BANK, N.A., AS TRUSTEE FOR THE HOLDERS OF SAMI II 2006-AR6, MORTGAGE PASS-THROUGH CERTIFICATES, SERIES 2006-AR6 is the Plaintiff and CARSTEN RUEFFER; NATIONAL CITY BANK; UNKNOWN TENANT(S) IN POSSESSION OF THE SUBJECT PROPERTY are defendants. The Clerk of this Court shall sell to the highest and best bidder for cash electronically at www.sarasota.real-

FIRST INSERTION

foreclose.com at, 9:00 AM on the 30th day of October, 2012, the following described property as set forth in said Final Judgment, to wit:

LOT 1041, SARAOTA SPRINGS, UNIT NO. 9, ACCORDING TO THE PLAT THEREOF RECORDED IN PLAT BOOK 8, PAGE 24, OF THE PUBLIC RECORDS OF SARASOTA COUNTY, FLORIDA.

ANY PERSON CLAIMING AN INTEREST IN THE SURPLUS FROM THE SALE, IF ANY, OTHER THAN THE PROPERTY OWNER AS OF THE DATE OF THE LIS PENDENS MUST FILE A CLAIM WITHIN 60 DAYS AFTER THE SALE.

In accordance with the Americans With Disabilities Act, persons needing a reasonable accommodation to participate in this proceeding should contact the Clerk of the Circuit Court no later than seven business days prior to the proceeding at the Sarasota County Courthouse. Telephone 941-861-7425 (Sarasota and Venice) or 1-800-955-8770 via Florida Relay Service.

Dated this 10 day of October, 2012.
By: Lucetta Pierre-Louis, Esq.
Bar Number: 86807

Submitted by:
LAW OFFICES OF MARSHALL C. WATSON, P.A. 1800 NW 49th Street, Suite 120 Fort Lauderdale, Florida 33309 Telephone: (954) 453-0365 Facsimile: (954) 771-6052 Toll Free: 1-800-441-2438 DESIGNATED PRIMARY E-MAIL FOR SERVICE PURSUANT TO FLA. R. JUD. ADMIN 2.516 eservice@marshallwatson.com 08-11846
October 12, 19, 2012 12-3979S

PUBLISH YOUR LEGAL NOTICES
IN THE GULF COAST BUSINESS REVIEW
(800) 403-2493 Hillsborough, Pasco
(727) 447-7784 Pinellas
(941) 906-9386 Manatee, Sarasota, Lee
(239) 594-5387 Collier

FIRST INSERTION

NOTICE OF FORECLOSURE SALE IN THE CIRCUIT COURT OF THE TWELFTH JUDICIAL CIRCUIT, IN AND FOR SARASOTA COUNTY, FLORIDA

CASE NO. 2012 CA 001407 NC
THIRD FEDERAL SAVINGS AND LOAN ASSOCIATION OF CLEVELAND, Plaintiff, vs. STEVEN J. HOPPE A/K/A STEVEN JON HOPPE, ET AL. Defendants

NOTICE IS HEREBY GIVEN pursuant to a Final Judgment of Foreclosure dated October 8, 2012, and entered in Case No. 2012 CA 001407 NC, of the Circuit Court of the Twelfth Judicial Circuit in and for SARASOTA County, Florida. THIRD FEDERAL SAVINGS AND LOAN ASSOCIATION OF CLEVELAND (hereafter "Plaintiff"), is Plaintiff and STEVEN J. HOPPE A/K/A STEVEN JON HOPPE, UNKNOWN SPOUSE OF STEVEN J. HOPPE A/K/A STEVEN JON HOPPE N/K/A KRISTINE HOPPE, CITIBANK, NATIONAL ASSOCIATION SUCCESSOR IN INTEREST TO CITIBANK (SOUTH DAKOTA), N.A.; UNKNOWN TENANT #1 IN POSSESSION OF SUBJECT PROPERTY N/K/A ROBERT HOPPE, are defendants. I will sell to the highest and best bidder for cash via the Internet at www.sarasota.realforeclose.com, at 9:00 a.m., on the 13th day of November, 2012, the following described property as set forth in said Final Judgment, to-wit:

LOT 1106, BLOCK , KENSINGTON PARK SUBDIVISION, UNIT 9, AS PER PLAT THEREOF, RECORDED IN PLAT BOOK 17, PAGE 48 AND 48A, OF THE PUBLIC RECORDS OF SARASOTA COUNTY, FLORIDA.

Any person claiming an interest in the surplus from the sale, if any, other than the property owner as of the date of the Lis Pendens must file a claim within 60 days after the sale.

In accordance with the Americans With Disabilities Act, persons needing a reasonable accommodation to participate in this proceeding should contact the Clerk of the Circuit Court no later than seven business days prior to the proceeding at the Sarasota County Courthouse. Telephone 941-861-7425 (Sarasota and Venice) or 1-800-955-8770 via Florida Relay Service.

KAREN RUSHING
CLERK OF THE CIRCUIT COURT BY _____

As Deputy Clerk
VAN NESS LAW FIRM, P.A.
1239 E. Newport Center Drive
Suite #110
Deerfield Beach, Florida 33442
Phone (954) 571-2031
Fax (954) 571-2033
FN2426-11TF/ee
October 12, 19, 2012 12-3962S

FIRST INSERTION

NOTICE OF FORECLOSURE SALE IN THE CIRCUIT COURT OF THE TWELFTH JUDICIAL CIRCUIT, IN AND FOR SARASOTA COUNTY, FLORIDA

CIVIL ACTION
CASE NO.: 2010-CA-000130-NC
DIVISION: A
CHASE HOME FINANCE LLC, Plaintiff, vs. ANNE C. HAZELL F/K/A ANNE C. MONTAGNESI, et al, Defendant(s).

NOTICE IS HEREBY GIVEN pursuant to a Final Judgment of Mortgage Foreclosure dated September 24, 2012 and entered in Case No. 2010-CA-000130-NC of the Circuit Court of the TWELFTH Judicial Circuit in and for SARASOTA County, Florida wherein JPMORGAN CHASE BANK, NATIONAL ASSOCIATION, SUCCESSOR BY MERGER TO CHASE HOME FINANCE LLC1, is the Plaintiff and ANNE C. HAZELL F/K/A ANNE C. MONTAGNESI; PAUL HAZELL; are the Defendants, The Clerk will sell to the highest and best bidder for cash at WWW.SARASOTA.REALFORECLOSE.COM at 9:00AM, on the 1st day of Novmber, 2012, the following described property as set forth in said Final Judgment:

LOT 11, BLOCK A, LONG MEADOW SUBDIVISION, SECOND ADDITION, AS PER PLAT THEREOF RECORDED IN PLAT BOOK 6, PAGE 16, OF THE PUBLIC RECORDS OF SARASOTA COUNTY, FLORIDA, TOGETHER WITH ALL IMPROVEMENTS LOCATED THEREON.

A/K/A 2324 BOUGAINVILLEA STREET, SARASOTA, FL 34239

Any person claiming an interest in the surplus from the sale, if any, other than the property owner as of the date of the Lis Pendens must file a claim within sixty (60) days after the sale.

In accordance with the Americans With Disabilities Act, persons needing a reasonable accommodation to participate in this proceeding should contact the Clerk of the Circuit Court no later than seven business days prior to the proceeding at the Sarasota County Courthouse. Telephone 941-861-7425 (Sarasota and Venice) or 1-800-955-8770 via Florida Relay Service.

By: Shilpini Vora Burriss
Florida Bar No. 27205
RONALD R WOLFE & ASSOCIATES, P.L.
P.O. Box 25018
Tampa, Florida 33622-5018
(813) 251-4766
F09126093
October 12, 19, 2012 12-3895S

FIRST INSERTION

NOTICE OF FORECLOSURE SALE IN THE CIRCUIT COURT OF THE TWELFTH JUDICIAL CIRCUIT, IN AND FOR SARASOTA COUNTY, FLORIDA

CIVIL ACTION
CASE NO.: 2010-CA-000487-NC
DIVISION: A
CHASE HOME FINANCE LLC SUCCESSOR BY MERGER TO CHASE MANHATTAN MORTGAGE CORPORATION, Plaintiff, vs. DONALD M. LEMOIE, et al, Defendant(s).

NOTICE IS HEREBY GIVEN pursuant to a Final Judgment of Mortgage Foreclosure dated September 24, 2012 and entered in Case No. 2010-CA-000487-NC of the Circuit Court of the TWELFTH Judicial Circuit in and for SARASOTA County, Florida wherein JPMORGAN CHASE BANK, NATIONAL ASSOCIATION, SUCCESSOR BY MERGER TO CHASE HOME FINANCE LLC1, is the Plaintiff and DONALD M. LEMOIE; SUSAN H. LEMOIE; CITIBANK, NATIONAL ASSOCIATION SUCCESSOR BY MERGER TO CITIBANK, FEDERAL SAVINGS BANK; are the Defendants, The Clerk will sell to the highest and best bidder for cash at WWW.SARASOTA.REALFORECLOSE.COM at 9:00AM, on the 1st day of November, 2012, the following described property as set forth in said Final Judgment:

LOTS 3161, 3162 AND 3163, SOUTH VENICE, UNIT NO. 11, ACCORDING TO THE PLAT THEREOF AS RECORDED IN PLAT BOOK 6, PAGE 47, PUBLIC RECORDS OF SARASOTA COUNTY, FLORIDA.

A/K/A 423 AZURE ROAD, VENICE, FL 34293

Any person claiming an interest in the surplus from the sale, if any, other than the property owner as of the date of the Lis Pendens must file a claim within sixty (60) days after the sale.

In accordance with the Americans With Disabilities Act, persons needing a reasonable accommodation to participate in this proceeding should contact the Clerk of the Circuit Court no later than seven business days prior to the proceeding at the Sarasota County Courthouse. Telephone 941-861-7425 (Sarasota and Venice) or 1-800-955-8770 via Florida Relay Service.

By: Scott R. Lin
Florida Bar No. 11277
RONALD R WOLFE & ASSOCIATES, P.L.
P.O. Box 25018
Tampa, Florida 33622-5018
(813) 251-4766
F10001594
October 12, 19, 2012 12-3897S

FIRST INSERTION

NOTICE OF SALE IN THE CIRCUIT COURT OF THE TWELFTH JUDICIAL CIRCUIT IN AND FOR SARASOTA COUNTY, FLORIDA

CIVIL DIVISION
Case #: 2010-CA-010429-NC
DIVISION: A
Nationwide Advantage Mortgage Company Plaintiff, vs.- Vincent J. Occhipinti and Grace E. McLaughlin a/k/a Grace McLaughlin; Gloria R. Occhipinti a/k/a Gloria Occhipinti; Midland Funding, LLC, as Successor in Interest to Aspire; Defendant(s).

NOTICE IS HEREBY GIVEN pursuant to an Order rescheduling foreclosure sale dated September 27, 2012, entered in Civil Case No. 2010-CA-010429-NC of the Circuit Court of the 12th Judicial Circuit in and for Sarasota County, Florida, wherein Nationwide Advantage Mortgage Company, Plaintiff and Vincent J. Occhipinti and Grace E. McLaughlin a/k/a Grace McLaughlin are defendant(s), I, will sell to the highest and best bidder for cash VIA THE INTERNET AT WWW.SARASOTA.REALFORECLOSE.COM , AT 9:00 A.M. on November 1, 2012, the following described property as set forth in said Final Judgment, to-wit:

THE SOUTH 1/2 OF LOT 8884, ALL OF LOTS 8885 AND 8886, SOUTH VENICE, UNIT NO. 32, AS PER PLAT THEREOF, RECORDED IN PLAT BOOK 6, PAGE 86, OF THE PUBLIC RECORDS OF SARASOTA COUNTY, FLORIDA.

ANY PERSON CLAIMING AN INTEREST IN THE SURPLUS FROM THE SALE, IF ANY, OTHER THAN THE PROPERTY OWNER AS OF THE DATE OF THE LIS PENDENS MUST FILE A CLAIM WITHIN 60 DAYS AFTER THE SALE.

In accordance with the Americans With Disabilities Act, persons needing a reasonable accommodation to participate in this proceeding should contact the Clerk of the Circuit Court no later than seven business days prior to the proceeding at the Sarasota County Courthouse. Telephone 941-861-7425 (Sarasota and Venice) or 1-800-955-8770 via Florida Relay Service.

By: Ella Roberts, Esquire
FL Bar # 75943

SHAPIRO, FISHMAN & GACHÉ, LLP
Attorneys for Plaintiff
2424 North Federal Highway,
Suite 360
Boca Raton, Florida 33431
Telephone: (561) 998-6700
Fax: (561) 998-6707
10-194407 FC01 ALL
October 12, 19, 2012 12-3960S

FIRST INSERTION

NOTICE OF SALE IN THE CIRCUIT COURT OF THE TWELFTH JUDICIAL CIRCUIT IN AND FOR SARASOTA COUNTY, FLORIDA

CIVIL DIVISION
Case #: 2009-CA-020566-NC
DIVISION: A
JPMorgan Chase Bank, National Association Plaintiff, vs.- Mathew Cheriyan a/k/a Matthew Cheriyan and Rachel Cheriyan, Husband and Wife; Wachovia Bank, National Association; Heron Creek Community Association, Inc.; Defendant(s).

NOTICE IS HEREBY GIVEN pursuant to an Order rescheduling foreclosure sale dated September 27, 2012, entered in Civil Case No. 2009-CA-020566-NC of the Circuit Court of the 12th Judicial Circuit in and for Sarasota County, Florida, wherein JPMorgan Chase Bank, National Association, Plaintiff and Mathew Cheriyan a/k/a Matthew Cheriyan and Rachel Cheriyan, Husband and Wife are defendant(s), I, Clerk of Court, KAREN E. RUSHING, will sell to the highest and best bidder for cash VIA THE INTERNET AT WWW.SARASOTA.REALFORECLOSE.COM , AT 9:00 A.M. on October 31, 2012, the following described property as set forth in said Final Judgment, to-wit:

LOT 390, HERON CREEK, UNIT 3, AS PER PLAT THEREOF, AS RECORDED IN PLAT BOOK 42, PAGES 29, 29A THROUGH 29K, OF THE PUBLIC RECORDS OF SARASOTA COUNTY, FLORIDA.

ANY PERSON CLAIMING AN INTEREST IN THE SURPLUS FROM THE SALE, IF ANY, OTHER THAN THE PROPERTY OWNER AS OF THE DATE OF THE LIS PENDENS MUST FILE A CLAIM WITHIN 60 DAYS AFTER THE SALE.

In accordance with the Americans With Disabilities Act, persons needing a reasonable accommodation to participate in this proceeding should contact the Clerk of the Circuit Court no later than seven business days prior to the proceeding at the Sarasota County Courthouse. Telephone 941-861-7425 (Sarasota and Venice) or 1-800-955-8770 via Florida Relay Service.

By: Ella Roberts, Esquire
FL Bar # 75943

SHAPIRO, FISHMAN & GACHÉ, LLP
Attorneys for Plaintiff
2424 North Federal Highway,
Suite 360
Boca Raton, Florida 33431
Telephone: (561) 998-6700
Fax: (561) 998-6707
09-160897 FC01 W50
October 12, 19, 2012 12-3959S

FIRST INSERTION

NOTICE OF SALE IN THE CIRCUIT COURT OF THE TWELFTH JUDICIAL CIRCUIT IN AND FOR SARASOTA COUNTY, FLORIDA

CIVIL DIVISION
Case #: 2010-CA-009138-NC
DIVISION: A
BAC Home Loans Servicing, L.P. f/k/a Countrywide Home Loans Servicing, L.P. Plaintiff, vs.- James A. Verity and Danielle Verity, Husband and Wife; Defendant(s).

NOTICE IS HEREBY GIVEN pursuant to an Order rescheduling foreclosure sale dated September 27, 2012, entered in Civil Case No. 2010-CA-009138-NC of the Circuit Court of the 12th Judicial Circuit in and for Sarasota County, Florida, wherein BAC Home Loans Servicing, L.P. f/k/a Countrywide Home Loans Servicing, L.P., Plaintiff and James A. Verity and Danielle Verity, Husband and Wife are defendant(s), I, will sell to the highest and best bidder for cash VIA THE INTERNET AT WWW.SARASOTA.REALFORECLOSE.COM , AT 9:00 A.M. on October 31, 2012, the following described property as set forth in said Final Judgment, to-wit:

LOT 56, BLOCK 930, 11TH ADDITION TO PORT CHARLOTTE SUBDIVISION, ACCORDING TO THE PLAT THEREOF, AS RECORDED IN PLAT BOOK 13, PAGE 2, OF THE PUBLIC RECORDS OF SARASOTA COUNTY, FLORIDA.

ANY PERSON CLAIMING AN INTEREST IN THE SURPLUS FROM THE SALE, IF ANY, OTHER THAN THE PROPERTY OWNER AS OF THE DATE OF THE LIS PENDENS MUST FILE A CLAIM WITHIN 60 DAYS AFTER THE SALE.

In accordance with the Americans With Disabilities Act, persons needing a reasonable accommodation to participate in this proceeding should contact the Clerk of the Circuit Court no later than seven business days prior to the proceeding at the Sarasota County Courthouse. Telephone 941-861-7425 (Sarasota and Venice) or 1-800-955-8770 via Florida Relay Service.

By: Ella Roberts, Esquire
FL Bar # 75943

SHAPIRO, FISHMAN & GACHÉ, LLP
Attorneys for Plaintiff
2424 North Federal Highway,
Suite 360
Boca Raton, Florida 33431
Telephone: (561) 998-6700
Fax: (561) 998-6707
10-184706 FC01 CWF
October 12, 19, 2012 12-3958S

FIRST INSERTION

NOTICE OF SALE IN THE CIRCUIT COURT OF THE TWELFTH JUDICIAL CIRCUIT IN AND FOR SARASOTA COUNTY, FLORIDA

CIVIL DIVISION
Case #: 2010-CA-005311-NC
DIVISION: C

BAC Home Loans Servicing, L.P. f/k/a Countrywide Home Loans Servicing, L.P. Plaintiff, vs.-

Michael E. Dolan; Admirals Walk Condominium Association, Inc.; Unknown Tenants in Possession #1; Unknown Tenants in Possession #2; If living, and all Unknown Tenants claiming by, through, under and against the above named Defendant(s) who are not known to be dead or alive, whether said Unknown Parties may claim an interest as Spouse, Heirs, Devisees, Grantees, or Other Claimants Defendant(s).

NOTICE IS HEREBY GIVEN pursuant to an Order rescheduling foreclosure sale dated September 27, 2012, entered in Civil Case No. 2010-CA-005311-NC of the Circuit

Court of the 12th Judicial Circuit in and for Sarasota County, Florida, wherein BAC Home Loans Servicing, L.P. f/k/a Countrywide Home Loans Servicing, L.P., Plaintiff and Michael E. Dolan are defendant(s), I, will sell to the highest and best bidder for cash VIA THE INTERNET AT WWW.SARASOTA.REALFORECLOSE.COM , AT 9:00 A.M. on October 31, 2012, the following described property as set forth in said Final Judgment, to-wit:

CONDOMINIUM UNIT NO. 204, BUILDING 6, ADMIRALS WALK, A CONDOMINIUM, TOGETHER WITH AN UNDIVIDED INTEREST IN THE COMMON ELEMENTS, ACCORDING TO THE DECLARATION OF CONDOMINIUM THEREOF, AS RECORDED IN INSTRUMENT NUMBER 2005102528, AS AMENDED FROM TIME TO TIME, OF THE PUBLIC RECORDS OF SARASOTA COUNTY, FLORIDA. ANY PERSON CLAIMING AN IN-

TEREST IN THE SURPLUS FROM THE SALE, IF ANY, OTHER THAN THE PROPERTY OWNER AS OF THE DATE OF THE LIS PENDENS MUST FILE A CLAIM WITHIN 60 DAYS AFTER THE SALE.

In accordance with the Americans With Disabilities Act, persons needing a reasonable accommodation to participate in this proceeding should contact the Clerk of the Circuit Court no later than seven business days prior to the proceeding at the Sarasota County Courthouse. Telephone 941-861-7425 (Sarasota and Venice) or 1-800-955-8770 via Florida Relay Service.

By: Ella Roberts, Esquire
FL Bar # 75943

SHAPIRO, FISHMAN & GACHÉ, LLP
Attorneys for Plaintiff
2424 North Federal Highway,
Suite 360
Boca Raton, Florida 33431
Telephone: (561) 998-6700
Fax: (561) 998-6707
10-172700 FC01 CWF
October 12, 19, 2012 12-3957S

FIRST INSERTION

NOTICE OF SALE PURSUANT TO CHAPTER 45 IN THE CIRCUIT COURT OF THE 12TH JUDICIAL CIRCUIT, IN AND FOR SARASOTA COUNTY, FLORIDA

CASE NO. 58-2009-001378 NC (C)
THE BANK OF NEW YORK MELLON, AS SUCCESSOR INDENTURE TRUSTEE UNDER NOVASTAR MORTGAGE FUNDING TRUST 2006-1 Plaintiff, vs. DIANA WILLIAMS, ET AL Defendants.

NOTICE IS HEREBY GIVEN pursuant to the Summary Final Judgment in Foreclosure dated January 7, 2011 and entered in Case No. 58-2009-001378 NC (C) of the Circuit Court of the 12TH Judicial Circuit in and for SARASOTA County, Florida, wherein THE BANK OF NEW YORK MELLON, AS SUCCESSOR INDENTURE TRUSTEE UNDER NOVASTAR MORTGAGE FUNDING TRUST 2006-1 is Plaintiff and DIANA WILLIAMS; AS UNKNOWN SPOUSE OF DIANA WILLIAMS; IF ANY; JOHN DOE OR ANY OTHER PERSON IN POSSESSION; MORTGAGE ELECTRONIC

FIRST INSERTION

REGISTRATION SYSTEMS, INC.; SUMMER WIND CONDOMINIUM ASSOCIATION OF SARASOTA, INC. A/K/A SUMMER WIND CONDOMINIUM ASSOCIATION, INC.; SARASOTA COUNTY, A POLITICAL SUBDIVISION OF THE STATE OF FLORIDA; are the Defendants, the clerk will sell to the highest and best bidder for cash at the WWW.SARASOTA.REALFORECLOSE.COM in SARASOTA County, Florida, at 9AM, on the 1st day of November, 2012, the following described property as set forth in said Order or Final Judgment, to wit:

UNIT 9, SUMMER WIND, A CONDOMINIUM, ACCORDING TO THE DECLARATION OF CONDOMINIUM THEREOF RECORDED IN OFFICIAL RECORDS BOOK 1607, PAGES 1617 THROUGH 1674, INCLUSIVE AND AMENDMENTS THERE TO, AND AS PER PLAT THEREOF RECORDED IN CONDOMINIUM BOOK 20, PAGES 49 AND 49A, OF THE PUBLIC RECORDS OF SARASOTA COUNTY, FLORIDA

Street Address: 4617 SUMMERWIND DR., UNIT #9, SARASOTA, FLORIDA 34234

Any person claiming an interest in the surplus from the sale, if any, other than the property owner as of the date of the lis pendens, must file a claim within sixty (60) days after the sale.

In accordance with the Americans With Disabilities Act, persons needing a reasonable accommodation to participate in this proceeding should contact the Clerk of the Circuit Court no later than seven business days prior to the proceeding at the Sarasota County Courthouse. Telephone 941-861-7425 (Sarasota and Venice) or 1-800-955-8770 via Florida Relay Service.

WITNESS my hand and the seal of the Court this 3 day of October, 2012.

By: Scott E. Simowitz, Esq.
FBN 306207
MOSKOWITZ, MANDELL, SALIM & SIMOWITZ, P.A.

Attorneys for Plaintiff
800 Corporate Drive, Suite 500
Fort Lauderdale, FLORIDA 33334
(954) 491-2000
(954) 491-2051 (TELEFAX)
October 12, 19, 2012 12-3886S

FIRST INSERTION

NOTICE OF RESCHEDULED FORECLOSURE SALE IN THE CIRCUIT COURT OF THE TWELFTH JUDICIAL CIRCUIT IN AND FOR SARASOTA COUNTY, FLORIDA

CIVIL DIVISION
CASE NO.: 2009 CA 6512 NC
DIVISION: C

VESTA EQUITY, LLC, a Florida Limited Liability Company, Plaintiff, v.

BELLA CITTA, LLC f/k/a VILLA LAGO, LLC, a Florida Limited Liability Company, JEFFREY O. GATES, an individual, MICHAEL K. GREIG, an individual, JAMES A. McLEOD, an individual, DALE E. DESJARDINS, an individual and STEPHEN L. HAZELTINE, an individual, CITY OF VENICE, FLORIDA, and JOHN DOE and JANE DOE, representing unknown parties that may be in

possession of the subject property, Defendants.

NOTICE IS HEREBY GIVEN, pursuant to a Uniform Final Judgment of Foreclosure dated July 20, 2012, entered in Civil Case No. 2009-CA-6512 NC of the Circuit Court of the Twelfth Judicial Circuit in and for Sarasota County, Sarasota, Florida, and the Order Granting Motion to Reset Foreclosure Sale, for Awarding of Post-Judgment Attorneys' Fees, Expenses and Costs, and for Sanctions Under Florida statutes § 57.105 entered by the Honorable Charles E. Williams on October 2, 2012, that I will sell to the highest and best bidder for cash through an on-line sale conducted at www.sarasota.realforeclose.com beginning at 9:00 a.m. on the 5th day of November, 2012 the following described property as set forth in said Uniform Final Judgment of Foreclosure, to-wit:
SEE ATTACHED Exhibit "A"

FIRST INSERTION

EXHIBIT "A"
LEGAL DESCRIPTION

A parcel of land lying and being in Section 32, Township 38 South, Range 19 East, Sarasota County, Florida and being more particularly described as follows:

Commence at the Southeast corner of Tract 12, according to the Plat of "SORRENTO RANCHES" as recorded in Plat Book 26, Pages 50 & 50-A, of the Public Records of Sarasota County, Florida; thence N 01°06'50" E, along the East line of the West 1/2 of the East 1/2 of said Section 32 as shown on the said Plat of "SORRENTO RANCHES" and along the Easterly line of the said Plat of "SORRENTO RANCHES" a distance of 850.86 feet to the Point of Beginning; thence N 01°06'50"E, continue along the

FIRST INSERTION

previously described line and its Northerly extension a distance of 1735.65 feet to the Northeast corner of the said Plat of "SORRENTO RANCHES"; thence N 89°20'57" E, along the North line of the Southeast 1/4 of the Northeast 1/4 of said Section 32, a distance of 1041.08 feet to the intersection with the Westerly line of the Sarasota County Detention Pond Area No. 2, as described in the Order of Taking recorded in O.R. Book 2890, Page 2781 of the said Public Records; thence S 40°37'08" W, along the Westerly and Southerly lines of the said Detention Pond Area No. 2 for the next four (4) calls a distance of 377.41 feet; thence S 00°16'17" W, a distance of 76.13 feet; thence S 68°16'42" E, a distance of 412.13 feet; thence S 89°55'39" E, a distance of 58.15

FIRST INSERTION

feet; to the intersection with the Westerly right of way line of Pinebrook Road, as recorded in the Order of Taking file in O.R. Book 2890, Page 2781, of the said Public Records; thence S 00°38'02" W, along the said Westerly right of way line of Pinebrook Road, for the next two (2) calls a distance of 793.20 feet; thence S 00°35'53"W, a distance of 444.92 feet to the Northeast corner of Detention Pond Area No. 1 as recorded in Order of Taking; thence N 89°43'15" W, along the Northerly line of the said Detention Pond Area No. 1 and tax parcels 0386-08-0001 and 0386-08-0004, a distance of 1256.29 feet to the Point of Beginning.
Any person claiming an interest in the surplus, if any, other than the property owner as of the date of the Lis Pendens,

FIRST INSERTION

must file a claim within 60 days after the sale.

In accordance with the Americans With Disabilities Act, persons needing a reasonable accommodation to participate in this proceeding should contact the Clerk of the Circuit Court no later than seven business days prior to the proceeding at the Sarasota County Courthouse. Telephone 941-861-7425 (Sarasota and Venice) or 1-800-955-8770 via Florida Relay Service.

Dated this 4th day of October, 2012.
Luis Martinez-Monfort, Esquire
Florida Bar No.: 0132713
GARDNER BREWER
MARTINEZ-MONFORT, P.A.
400 N. Tampa Street, Suite 2600
Tampa, Florida 33602
Telephone: 813.221.9600
Facsimile: 813.221.9611
Email: lmonfort@gbmlaw.com
Attorneys for Vesta Equity, LLC
October 12, 19, 2012 12-3878S

FIRST INSERTION
NOTICE TO CREDITORS
IN THE CIRCUIT COURT FOR
SARASOTA COUNTY, FLORIDA
PROBATE DIVISION
File No. 2012 CP 003671 NC
IN RE: Estate of:
BERNICE A. SIENKIEWICZ,
Deceased.

The administration of the Estate of BERNICE A. SIENKIEWICZ, deceased, whose date of death was November 5, 2011, is in the Circuit Court in the County for Sarasota County, Florida, Probate Division; the address of which is: Sarasota County Courthouse, Probate Division, 2000 Main Street, Sarasota, FL 34237.

The names and addresses of the personal representative and the personal representative's attorney is set forth below.

All creditors of the decedent and other persons, having claims or demands against decedent's estate, on whom a copy of this notice has been served must file their claims with this court WITHIN THE LATER OF THREE (3) MONTHS AFTER THE DATE OF THE FIRST PUBLICATION OF THIS NOTICE OR THIRTY (30) DAYS AFTER THE DATE OF SERVICE OF A COPY OF THIS NOTICE ON THEM.

All other creditors of the decedent, and other persons having claims or demands against decedent's estate, must file their claims with the court WITHIN THREE (3) MONTHS AFTER THE DATE OF THE FIRST PUBLICATION OF THIS NOTICE.

ALL CLAIMS NOT SO FILED WILL BE FOREVER BARRED.
NOTWITHSTANDING THE TIME PERIOD SET FORTH ABOVE, ANY CLAIM FILED TWO (2) YEARS OR MORE AFTER THE DECEDENT'S DATE OF DEATH IS BARRED.
THE DATE OF FIRST PUBLICATION OF THIS NOTICE IS: October 12, 2012.

Personal Representative:
Delores M. Simpson
Personal Representative of BERNICE A. SIENKIEWICZ, Deceased.
Attorney for Personal Representative: HAROLD W. SCOVILL, Esquire
Attorney for the Personal Representative of the Estate of BERNICE A. SIENKIEWICZ, Deceased.
1605 Main Street, Suite 912
Sarasota, Florida 34236
(941) 365-2252
Florida Bar No. 097880
October 12, 19, 2012 12-3909S

FIRST INSERTION
NOTICE OF ACTION
IN THE CIRCUIT COURT OF THE
12TH JUDICIAL CIRCUIT, IN
AND FOR SARASOTA COUNTY,
FLORIDA
CASE NO. 2012 CA 006140 NC
JPMORGAN CHASE BANK,
NATIONAL ASSOCIATION
Plaintiff, vs
ROBERT WOODBRIDGE, ET AL
Defendants
TO: ELAINE WOODBRIDGE
6589 PIMLICO STREET
NORTHPORT, FL 34286
ELAINE WOODBRIDGE
4118 COLONY CROSSING DR
SUGAR LAND, TX 77479
AND TO: All persons claiming an interest by, through, under, or against the aforesaid Defendant(s).

YOU ARE HEREBY NOTIFIED that an action to foreclose a mortgage on the following described property located in Sarasota County, Florida:
Lot 8, Block 15 of FIRST ADDITION TO NORTH PORT CHARLOTTE ESTATES, according to the Plat thereof as recorded in Plat Book 19, Page(s) 29, 29-A through 29-J, of the Public Records of Sarasota County, Florida

has been filed against you and you are required to serve a copy of your written defenses, if any, to this action, on Greenspoon Marder, P.A., Default Department, Attorneys for Plaintiff, whose address is Trade Centre South, Suite 700, 100 West Cypress Creek Road, Fort Lauderdale, FL 33309, and file the original with the Clerk within 30 days after the first publication of this notice in THE GULF COAST BUSINESS REVIEW, or on or before 11/13/2012; otherwise a default judgment may be entered against you for the relief demanded in the Complaint.

In accordance with the Americans With Disabilities Act, persons needing a reasonable accommodation to participate in this proceeding should contact the Clerk of the Circuit Court no later than seven business days prior to the proceeding at the Sarasota County Courthouse. Telephone 941-861-7425 (Sarasota and Venice) or 1-800-955-8770 via Florida Relay Service.

WITNESS MY HAND AND SEAL OF SAID COURT on this 3 day of October, 2012.
KAREN E. RUSHING
As Clerk of said Court
(SEAL) By: M. Foulks
As Deputy Clerk
GREENSPOON MARDER, P.A.
Attorneys for Plaintiff
Default Department
Trade Centre South, Suite 700
100 West Cypress Creek Road
Fort Lauderdale, FL 33309
October 12, 19, 2012 12-3879S

FIRST INSERTION
NOTICE TO CREDITORS
IN THE CIRCUIT COURT FOR
SARASOTA COUNTY, FLORIDA
PROBATE DIVISION
File No. 2012 CP 3267 NC
Division Probate
IN RE: ESTATE OF
FRED MINTZ
Deceased.

The administration of the estate of Fred Mintz, deceased, whose date of death was June 27, 2012, is pending in the Circuit Court for Sarasota County, Florida, Probate Division, the address of which is 2000 Main Street, Sarasota, FL 34237. The names and addresses of the personal representative and the personal representative's attorney are set forth below.

All creditors of the decedent and other persons having claims or demands against decedent's estate on whom a copy of this notice is required to be served must file their claims with this court WITHIN THE LATER OF 3 MONTHS AFTER THE TIME OF THE FIRST PUBLICATION OF THIS NOTICE OR 30 DAYS AFTER THE DATE OF SERVICE OF A COPY OF THIS NOTICE ON THEM.

All other creditors of the decedent and other persons having claims or demands against decedent's estate must file their claims with this court WITHIN 3 MONTHS AFTER THE DATE OF THE FIRST PUBLICATION OF THIS NOTICE.

ALL CLAIMS NOT FILED WITHIN THE TIME PERIODS SET FORTH IN SECTION 733.702 OF THE FLORIDA PROBATE CODE WILL BE FOREVER BARRED.
NOTWITHSTANDING THE TIME PERIODS SET FORTH ABOVE, ANY CLAIM FILED TWO (2) YEARS OR MORE AFTER THE DECEDENT'S DATE OF DEATH IS BARRED.
The date of first publication of this notice is October 12, 2011.

Personal Representative:
Robert E. Mintz
2018 Duke Drive
Anchorage, Alaska 99508
Attorney for Personal Representative: IRA S. WIESNER, Esq.
Attorney for Robert E. Mintz
Florida Bar Number: 222887
PROFESSIONAL ASSOCIATION,
ADVOCATES IN AGING
328 N. Rhodes Avenue
Sarasota, Florida 34237
Telephone: (941) 365-9900
Fax: (941) 365-4479
E-Mail: advocates@wiesnerlaw.com
October 12, 19, 2012 12-3953S

FIRST INSERTION
NOTICE OF SALE AS TO COUNT III
IN THE COUNTY COURT OF THE
TWELFTH JUDICIAL CIRCUIT
IN AND FOR SARASOTA COUNTY,
FLORIDA
CIVIL DIVISION
CASE NO. 2011 CC 5379 NC
VERANDA BEACH CLUB
CONDOMINIUM ASSOCIATION,
INC., a Florida not for profit
corporation,
Plaintiff, vs.
JEFFREY A. SEGOBIANO, et al
Defendants.

NOTICE IS HEREBY GIVEN that, pursuant to a Final Judgment as to Count III of the Complaint dated October 3, 2012, and entered in Case No.: 2011 CC 005379 NC of the County Court of the Twelfth Judicial Circuit in and for Sarasota County, Florida, the Clerk of the Court will sell the property situated in Sarasota County, Florida, described as:
Unit 210, Week 32, VERANDA BEACH CLUB, a Condominium according to the Declaration of Condominium thereof, recorded in Official Records Book 1525, Page 1328, of the Public Records of Sarasota County, Florida, and any amendments thereto, together with its undivided share in the common elements.

to the highest and best bidder for cash at www.sarasota.realforeclose.com, at 9:00 a.m. on the 7th day of November, 2012.

ANY PERSON CLAIMING AN INTEREST IN THE SURPLUS FROM THE SALE, IF ANY, OTHER THAN THE PROPERTY OWNER AS OF THE DATE OF THE LIS PENDENS MUST FILE A CLAIM WITHIN SIXTY (60) DAYS AFTER THE SALE.
In accordance with the Americans With Disabilities Act, persons needing a reasonable accommodation to participate in this proceeding should contact the Clerk of the Circuit Court no later than seven business days prior to the proceeding at the Sarasota County Courthouse. Telephone 941-861-7425 (Sarasota and Venice) or 1-800-955-8770 via Florida Relay Service.
Dated: October 5, 2012
HANKIN, PERSSON,
McCLENATHEN,
COHEN & DARNELL
By: /s/ Kelly M. Fernandez
Kelly M. Fernandez, Esq.
Florida Bar No. 0676081
1820 Ringling Boulevard
Sarasota, FL 34236
Telephone: (941) 365-4950
Facsimile: (941) 365-3259
kfernandez@sarasotalawfirm.com
COUNSEL FOR PLAINTIFF
October 12, 19, 2012 12-3882S

FIRST INSERTION
NOTICE OF FORECLOSURE SALE
IN THE CIRCUIT COURT OF THE
TWELFTH JUDICIAL CIRCUIT IN
AND FOR SARASOTA COUNTY,
FLORIDA
GENERAL JURISDICTION
DIVISION
CASE NO. 58-2010-CA-007422 NC
CITIMORTGAGE, INC.,
Plaintiff, vs.
MARK A BLANEY AND
LESLEY J BLANEY, et al.
Defendant.

NOTICE IS HEREBY GIVEN pursuant to a Final Judgment of Foreclosure dated SEPTEMBER 24, 2012, and entered in Case No. 58-2010-CA-007422 NC of the Circuit Court of the Twelfth Judicial Circuit in and for Sarasota County, Florida, wherein CITIMORTGAGE, INC., is the Plaintiff and MARK A BLANEY; BANK OF AMERICA, NA; LESLEY J. BLANEY; UNKNOWN TENANT(S) are the Defendant(s). Karen Rushing as the Clerk of the Circuit Court will sell to the highest and best bidder for cash www.sarasota.realforeclose.com, at 09:00AM on OCTOBER 30, 2012, the following described property as set forth in said Final Judgment, to-wit:
LOTS 16793, 16794 AND THE EAST 1/2 OF LOT 16795, SOUTH VENICE UNIT NO. 63, ACCORDING TO THAT CERTAIN PLAT AS RECORDED IN PLAT BOOK 7, PAGE(S) 40, PUBLIC RECORDS OF SARASOTA COUNTY, FLORIDA.

Any person claiming an interest in the surplus from the sale, if any, other than the property owner as of the date of the lis pendens must file a claim within 60 days after the sale.
In accordance with the Americans With Disabilities Act, persons needing a reasonable accommodation to participate in this proceeding should contact the Clerk of the Circuit Court no later than seven business days prior to the proceeding at the Sarasota County Courthouse. Telephone 941-861-7425 (Sarasota and Venice) or 1-800-955-8770 via Florida Relay Service.
Dated this 5 day of October, 2012.
By: Cedric C. Small
Florida Bar No. 70679
for Jamie Epstein
Florida Bar: 68691

ROBERTSON, ANSCHUTZ & SCHNEID, PL
Attorneys for Plaintiff
3010 North Military Trail, Suite 300
Boca Raton, Florida 33431
Telephone: 561-241-6901
Fax: 561-241-9181
11-07459
October 12, 19, 2012 12-3943S

FIRST INSERTION
NOTICE OF FORECLOSURE SALE
IN THE CIRCUIT COURT OF THE
TWELFTH JUDICIAL CIRCUIT, IN
AND FOR SARASOTA COUNTY,
FLORIDA
CIVIL ACTION
CASE NO.: 2011-CA-004640-NC
DIVISION: C
PHH MORTGAGE
CORPORATION,
Plaintiff, vs.
HOWARD BERTRAM A/K/A
HOWARD T. BERTRAM A/K/A
HOWARD THOMAS BERTRAM
, et al,
Defendant(s).

NOTICE IS HEREBY GIVEN pursuant to a Final Judgment of Mortgage Foreclosure dated September 24, 2012 and entered in Case No. 2011-CA-004640-NC of the Circuit Court of the TWELFTH Judicial Circuit in and for SARASOTA County, Florida wherein PHH MORTGAGE CORPORATION is the Plaintiff and HOWARD BERTRAM A/K/A HOWARD T. BERTRAM A/K/A HOWARD THOMAS BERTRAM; INSTAMORTGAGE.COM; are the Defendants. The Clerk will sell to the highest and best bidder for cash at WWW.SARASOTA.REALFORECLOSE.COM at 9:00AM, on the 1st day of November, 2012, the following described property as set forth in said Final Judgment:
LOT 2, BLOCK B, FORD SUBDIVISION, AS PER PLAT THEREOF RECORDED IN PLAT BOOK 5, PAGE 7, PUBLIC RECORDS OF SARASOTA COUNTY, FLORIDA
A/K/A 1177 38TH STREET, SARASOTA, FL 34234

Any person claiming an interest in the surplus from the sale, if any, other than the property owner as of the date of the Lis Pendens must file a claim within sixty (60) days after the sale.
In accordance with the Americans With Disabilities Act, persons needing a reasonable accommodation to participate in this proceeding should contact the Clerk of the Circuit Court no later than seven business days prior to the proceeding at the Sarasota County Courthouse. Telephone 941-861-7425 (Sarasota and Venice) or 1-800-955-8770 via Florida Relay Service.
By: William Jefferson
Florida Bar No. Pending

RONALD R WOLFE & ASSOCIATES, P.L.
P.O. Box 25018
Tampa, Florida 33622-5018
(813) 251-4766
F11007947
October 12, 19, 2012 12-3899S

FIRST INSERTION
NOTICE OF FORECLOSURE SALE
IN THE CIRCUIT COURT OF THE
TWELFTH JUDICIAL CIRCUIT, IN
AND FOR SARASOTA COUNTY,
FLORIDA
CIVIL ACTION
CASE NO.: 2011-CA-000216-NC
DIVISION: A
WELLS FARGO BANK, NA,
Plaintiff, vs.
ANTHONY J. WAGENER SMITH,
et al,
Defendant(s).

NOTICE IS HEREBY GIVEN pursuant to a Final Judgment of Mortgage Foreclosure dated July 30, 2012 and entered in Case No. 2011-CA-000216-NC of the Circuit Court of the TWELFTH Judicial Circuit in and for SARASOTA County, Florida wherein WELLS FARGO BANK, NA is the Plaintiff and ANTHONY J. WAGENER SMITH; LIANRO WAGENER SMITH; are the Defendants. The Clerk will sell to the highest and best bidder for cash at WWW.SARASOTA.REALFORECLOSE.COM at 9:00AM, on the 5th day of November, 2012, the following described property as set forth in said Final Judgment:
LOT 47, BLOCK 2468, 49TH ADDITION TO PORT CHARLOTTE SUBDIVISION, ACCORDING TO THE PLAT THEREOF, RECORDED IN PLAT BOOK 21, PAGE 1, 1 A THROUGH 1TT, OF THE PUBLIC RECORDS OF SARASOTA COUNTY, FLORIDA.
A/K/A 4230 CROMEY ROAD, NORTH PORT, FL 34286

Any person claiming an interest in the surplus from the sale, if any, other than the property owner as of the date of the Lis Pendens must file a claim within sixty (60) days after the sale.
In accordance with the Americans With Disabilities Act, persons needing a reasonable accommodation to participate in this proceeding should contact the Clerk of the Circuit Court no later than seven business days prior to the proceeding at the Sarasota County Courthouse. Telephone 941-861-7425 (Sarasota and Venice) or 1-800-955-8770 via Florida Relay Service.
By: Matthew Wolf
Florida Bar No. 92611

RONALD R WOLFE & ASSOCIATES, P.L.
P.O. Box 25018
Tampa, Florida 33622-5018
(813) 251-4766
F10108375
October 12, 19, 2012 12-3896S

FIRST INSERTION
NOTICE OF FORECLOSURE SALE
IN THE CIRCUIT COURT OF THE
TWELFTH JUDICIAL CIRCUIT, IN
AND FOR SARASOTA COUNTY,
FLORIDA
CIVIL ACTION
CASE NO.: 58-2012-CA-002323 NC
DIVISION: C
WELLS FARGO BANK, NA,
Plaintiff, vs.
CHRISTINE R. ALESSANDRO,
et al,
Defendant(s).

NOTICE IS HEREBY GIVEN pursuant to a Final Judgment of Mortgage Foreclosure dated September 24, 2012 and entered in Case No. 58-2012-CA-002323 NC of the Circuit Court of the TWELFTH Judicial Circuit in and for SARASOTA County, Florida wherein WELLS FARGO BANK, NA is the Plaintiff and CHRISTINE R. ALESSANDRO; TENANT #1 N/K/A LINSEY WHITE, and TENANT #2 N/K/A SUSAN JENSEN are the Defendants. The Clerk will sell to the highest and best bidder for cash at WWW.SARASOTA.REALFORECLOSE.COM at 9:00AM, on the 1st day of November, 2012, the following described property as set forth in said Final Judgment:
LOT 4, BLOCK 2573, FIFTY-FIRST ADDITION TO PORT CHARLOTTE SUBDIVISION, AS PER PLAT THEREOF RECORDED IN PLAT BOOK 21, PAGE 8, 8A THROUGH 8GG, OF THE PUBLIC RECORDS OF SARASOTA COUNTY, FLORIDA.
A/K/A 5228 ANDRIS STREET, NORTH PORT, FL 34288-7315

Any person claiming an interest in the surplus from the sale, if any, other than the property owner as of the date of the Lis Pendens must file a claim within sixty (60) days after the sale.
In accordance with the Americans With Disabilities Act, persons needing a reasonable accommodation to participate in this proceeding should contact the Clerk of the Circuit Court no later than seven business days prior to the proceeding at the Sarasota County Courthouse. Telephone 941-861-7425 (Sarasota and Venice) or 1-800-955-8770 via Florida Relay Service.
By: William A. Malone
Florida Bar No. 28079

RONALD R WOLFE & ASSOCIATES, P.L.
P.O. Box 25018
Tampa, Florida 33622-5018
(813) 251-4766
F12001616
October 12, 19, 2012 12-3900S

FIRST INSERTION
NOTICE OF SALE
IN THE CIRCUIT COURT OF THE
TWELFTH JUDICIAL CIRCUIT
IN AND FOR SARASOTA COUNTY,
FLORIDA
CIVIL ACTION
CASE NO.: 2012 CA 5988 NC
47th STREET INDUSTRIAL
COMMERCIAL CONDOMINIUM
ASSOCIATION, INC.,
Plaintiff, vs.
DAVID BRANCH and
LEIGH BRANCH,
Defendants.

NOTICE IS HEREBY GIVEN pursuant to an Order of Final Judgment of Foreclosure dated October 2, 2012, entered in Civil Case No.: 2012 CA 5988 NC, of the Circuit Court of the Twelfth Judicial Circuit in and for Sarasota County, Florida, wherein 47th Street Industrial Commercial Condominium Association, Inc. is the Plaintiff and David Branch and Leigh Branch are the Defendants. I will sell to the highest bidder for cash via foreclosure sale conducted via the Internet at www.sarasota.realforeclose.com at 9:00 a.m. on November 5, 2012, the following described property as set forth in said Final Judgment, to-wit:
Units 7 & 8, Phase 2, 47th Street Industrial Commercial Condominium, according to the Declaration of Condominium recorded in Official Records, as Instrument No. 1999129237-55 pages, of the Public Records of Sarasota County, Florida, and according to the plat thereof recorded in Condominium Book 33, pages 38-38A of the Public Records of Sarasota County, Florida.

ANY PERSON CLAIMING AN INTEREST IN THE SURPLUS FROM THE SALE, IF ANY, OTHER THAN THE PROPERTY OWNER AS OF THE DATE OF THE LIS PENDENS MUST FILE A CLAIM WITHIN 60 DAYS AFTER THE SALE.

In accordance with the Americans With Disabilities Act, persons needing a reasonable accommodation to participate in this proceeding should contact the Clerk of the Circuit Court no later than seven business days prior to the proceeding at the Sarasota County Courthouse. Telephone 941-861-7425 (Sarasota and Venice) or 1-800-955-8770 via Florida Relay Service.

DATED at Sarasota, Sarasota County, Florida this 3 day of October, 2012.
ALEXANDER G. PADEREWSKI
October 12, 19, 2012 12-3888S

FIRST INSERTION
NOTICE OF SALE
IN THE COUNTY COURT IN
AND FOR SARASOTA COUNTY,
FLORIDA
DIVISION: CIVIL
CASE NUMBER:
2011 CC 004145 SC
PLAINTIFF(S)
VILLAGEWALK OF SARASOTA
HOMEOWNERS ASSOCIATION,
INC.
VS. DEFENDANT(S)
SUZANNE K. KELLY,
COUNTRYWIDE HOME LOANS
SERVICING, L.P., WELLS
FARGO BANK, N.A., and CHASE
MANHATTAN BANK, USA.

Notice is hereby given pursuant to the final judgment/order entered in the above noted case, that I will sell the following property situated in Sarasota County, Florida, described as:
Lot 836, VILLAGEWALK, UNIT 4A, according to the Plat thereof, as recorded in Plat Book 44, Pages 2 through 2D, inclusive, of the Public Records of Sarasota County, Florida.

at public sale, to the highest and best bidder for cash, via the internet: www.sarasota.realforeclose.com at 9:00 a.m. on November 2, 2012. Final payment must be made on or before 4:00 p.m. of the date of the sale by cash or cashier's check, or initiated ACH or Wire Transfer.
IF YOU ARE A PERSON CLAIMING A RIGHT TO FUNDS REMAINING AFTER THE SALE, YOU MUST FILE A CLAIM WITH THE CLERK NO LATER THAN 60 DAYS AFTER THE SALE. IF YOU FAIL TO FILE A CLAIM, YOU WILL NOT BE ENTITLED TO ANY REMAINING FUNDS. AFTER 60 DAYS, ONLY THE OWNER OF RECORD AS OF THE DATE OF THE LIS PENDENS MAY CLAIM THE SURPLUS.
In accordance with the Americans With Disabilities Act, persons needing a reasonable accommodation to participate in this proceeding should contact the Clerk of the Circuit Court no later than seven business days prior to the proceeding at the Sarasota County Courthouse. Telephone 941-861-7425 (Sarasota and Venice) or 1-800-955-8770 via Florida Relay Service.
DATE: October 8, 2012.
KAREN E. RUSHING
CLERK OF THE CIRCUIT COURT
(SEAL) BY: Carolyn Stacy,
Deputy Clerk

KANETSKY, MOORE & DEBOER, P.A.
P.O. Box 1767
Venice, FL 34284-1767
October 12, 19, 2012 12-3949S

FIRST INSERTION
NOTICE OF FORECLOSURE SALE
IN THE CIRCUIT COURT OF THE
TWELFTH JUDICIAL CIRCUIT, IN
AND FOR SARASOTA COUNTY,
FLORIDA
CIVIL ACTION
CASE NO.: 58-2012-CA-002586 NC
DIVISION: A
BANK OF AMERICA, N.A.,
Plaintiff, vs.
BRUCE M. WHITNEY, et al,
Defendant(s).

NOTICE IS HEREBY GIVEN pursuant to a Final Judgment of Mortgage Foreclosure dated September 24, 2012 and entered in Case No. 58-2012-CA-002586 NC of the Circuit Court of the TWELFTH Judicial Circuit in and for SARASOTA County, Florida wherein BANK OF AMERICA, N.A. is the Plaintiff and BRUCE M. WHITNEY; CONNIE L. WHITNEY; BANK OF AMERICA, NA; are the Defendants. The Clerk will sell to the highest and best bidder for cash at WWW.SARASOTA.REALFORECLOSE.COM at 9:00AM, on the 1st day of November, 2012, the following described property as set forth in said Final Judgment:
LOTS 8505, 8506 AND THE SOUTHERLY 10 FEET OF LOT 8507, SOUTH VENICE UNIT NO. 30, ACCORDING TO THE PLAT THEREOF, AS RECORDED IN PLAT BOOK 6, PAGE 83, PUBLIC RECORDS OF SARASOTA COUNTY, FLORIDA

A/K/A 621 INDUS ROAD, VENICE, FL 34293
Any person claiming an interest in the surplus from the sale, if any, other than the property owner as of the date of the Lis Pendens must file a claim within sixty (60) days after the sale.

In accordance with the Americans With Disabilities Act, persons needing a reasonable accommodation to participate in this proceeding should contact the Clerk of the Circuit Court no later than seven business days prior to the proceeding at the Sarasota County Courthouse. Telephone 941-861-7425 (Sarasota and Venice) or 1-800-955-8770 via Florida Relay Service.
By: Andrea D. Pidala
Florida Bar No. 0022848

RONALD R WOLFE & ASSOCIATES, P.L.
P.O. Box 25018
Tampa, Florida 33622-5018
(813) 251-4766
F10125519
October 12, 19, 2012 12-3894S

FIRST INSERTION
NOTICE OF SALE
IN THE CIRCUIT COURT OF THE
TWELFTH JUDICIAL CIRCUIT
IN AND FOR SARASOTA COUNTY,
FLORIDA,
CIVIL DIVISION
CASE NO.: 2010 CA 001635 NC
WELLS FARGO BANK, N.A., NOT
IN ITS INDIVIDUAL CAPACITY
BUT SOLELY AS TRUSTEE FOR
RMAC REMIC TRUST, SERIES
2009-3
Plaintiff vs.
MICHAEL E. COOPER; OF
UNKNOWN SPOUSE OF
MICHAEL E. COOPER; STATE
OF FLORIDA DEPARTMENT OF
REVENUE; TRINA JENKINS;
UNKNOWN TENANT #1;
UNKNOWN TENANT #2,
Defendants

Notice is hereby given pursuant to the final judgment/order entered in the above noted case, that I will sell the following property situated in Sarasota County, Florida described as:
THE EAST 60 FEET OF LOT 325, AND THE WEST 20 FEET OF LOT 326, PHILLIPPI GARDENS, UNIT NO. 3, AS PER PLAT THEREOF, RECORDED IN PLAT BOOK 10, PAGE 80, PUBLIC RECORDS OF SARASOTA COUNTY, FLORIDA.

The Clerk of this Court shall sell the property to the highest bidder for cash, on December 7, 2012 at 9:00 a.m. on Sarasota County's Public Auction website: www.sarasota.realforeclosure.com in accordance with Chapter 45, Florida Statutes.
ANY PERSON CLAIMING AN INTEREST IN THE SURPLUS FROM THE SALE, IF ANY, OTHER THAN THE PROPERTY OWNER AS OF THE DATE OF THE LIS PENDENS MUST FILE A CLAIM WITHIN 60 DAYS AFTER THE SALE

In accordance with the Americans With Disabilities Act, persons needing a reasonable accommodation to participate in this proceeding should contact the Clerk of the Circuit Court no later than seven business days prior to the proceeding at the Sarasota County Courthouse. Telephone 941-861-7425 (Sarasota and Venice) or 1-800-955-8770 via Florida Relay Service.
LAW OFFICE OF
GARY I. GASSEL, P.A.
2191 Ringling Boulevard
Sarasota, Florida 34237
(941) 952-9322
Attorney for Plaintiff
By: /s/ Gary I. Gassel
GARY I. GASSEL, ESQUIRE
Florida Bar No. 500690
October 12, 19, 2012 12-3956S

FIRST INSERTION

NOTICE OF SALE
IN THE CIRCUIT COURT OF THE
TWELFTH JUDICIAL CIRCUIT
IN AND FOR SARASOTA COUNTY,
FLORIDA

CIVIL DIVISION
CASE NO.: 2009-CA-019285-NC
CADENCE BANK, N.A.,
Plaintiff, vs.
MICHAEL A. DULL, et al.
Defendants.

NOTICE IS HEREBY GIVEN pursuant to the Amended Final Judgment of Foreclosure of Plaintiff, CADENCE BANK, N.A., and determination of reasonable attorney's fees entered in the above-styled case number 2009-CA-019285-NC in the Circuit Court of Sarasota County, Florida, that Karen E. Rushing, Sarasota Clerk of the Court, will sell the following property situated in Sarasota County, Florida, described as:

- a. County: Sarasota
- b. Property Address:
1236 5th Street, Sarasota, FL 34236
- c. Legal Description:
Lots 9 and 11, Block 26, PLAT OF SARASOTA, according to the plat thereof, as recorded in Plat Book 1, Page 21, of the Public Records of Manatee County, Florida, and Plat Book A, Page 29, of the Public Records of Sarasota County, Florida.
- d. Parcel ID Number: 2026-12-0055

at public sale, to the highest and best bidder for cash, via the internet website www.sarasota.realforeclose.com, in accordance with Section 45.031, Florida Statutes, at 9:00 a.m. on November 2, 2012.

ANY PERSON CLAIMING AN INTEREST IN THE SURPLUS FROM THE SALE, IF ANY, OTHER THAN THE PROPERTY OWNER AS OF THE DATE OF THE LIS PENDENS MUST FILE A CLAIM WITHIN 60 DAYS AFTER THE SALE.

In accordance with the Americans With Disabilities Act, persons needing a reasonable accommodation to participate in this proceeding should contact the Clerk of the Circuit Court no later than seven business days prior to the proceeding at the Sarasota County Courthouse. Telephone 941-861-7425 (Sarasota and Venice) or 1-800-955-8770 via Florida Relay Service.

DATED on October 8th, 2012.
FOR THE COURT
By: J. Derrick Maginness
Florida Bar No. 026487

J. Derrick Maginness, Esq.
NORTON HAMMERSLEY
LOPEZ & SKOKOS, P.A.
1819 Main Street, Suite 610
Sarasota, Florida 34236
Telephone: 941-954-4691
Facsimile: 941-954-2128
dmaginness@nhslaw.com
Attorney for Plaintiff
October 12, 19, 2012 12-3950S

FIRST INSERTION

NOTICE OF FORECLOSURE SALE
IN THE CIRCUIT COURT OF THE
12TH JUDICIAL CIRCUIT, IN
AND FOR SARASOTA COUNTY,
FLORIDA

CIVIL DIVISION
CASE NO. 2010 CA 006549 NC
HSBC BANK USA, NATIONAL
ASSOCIATION AS TRUSTEE FOR
LUMINENT MORTGAGE TRUST
2006-3.

Plaintiff, vs.
BRENT K. TOONE; et al.,
Defendants.

NOTICE IS HEREBY GIVEN pursuant to a Final Judgment of Foreclosure filed September 24, 2012, and entered in Case No. 2010 CA 006549 NC, of the Circuit Court of the 12th Judicial Circuit in and for SARASOTA County, Florida. HSBC BANK USA, NATIONAL ASSOCIATION AS TRUSTEE FOR LUMINENT MORTGAGE TRUST 2006-3. is Plaintiff and BRENT K. TOONE; JENNIFER L. TOONE; UNKNOWN PERSON(S) IN POSSESSION OF THE SUBJECT PROPERTY; BANK OF AMERICA, N.A.; PARKRIDGE CONDOMINIUM ASSOCIATION, INC.; are defendants. The Clerk of Court will sell to the highest and best bidder for cash by electronic sale at: www.sarasota.realforeclose.com, at 9:00 a.m., on the 30th day of October, 2012, the following described property as set forth in said Final Judgment, to wit:

UNIT 2-103, PHASE 2,
PARKRIDGE CONDOMINIUM, A CONDOMINIUM, ACCORDING TO THE DECLARATION OF CONDOMINIUM THEREOF, AS RECORDED UNDER CLERKS FILE NO. 2004046838, OF THE PUBLIC RECORDS OF SARASOTA COUNTY, FLORIDA.

A person claiming an interest in the surplus from the sale, if any, other than the property owner as of the date of the lis pendens must file a claim within 60 days after the sale.

In accordance with the Americans With Disabilities Act, persons needing a reasonable accommodation to participate in this proceeding should contact the Clerk of the Circuit Court no later than seven business days prior to the proceeding at the Sarasota County Courthouse. Telephone 941-861-7425 (Sarasota and Venice) or 1-800-955-8770 via Florida Relay Service.

Dated this 8th day of October, 2012.
Stacy Robins, Esq.
Bar No.: 008079

Submitted by:
KAHANE & ASSOCIATES, P.A.
8201 Peters Road, Ste.3000
Plantation, FL 33324
Telephone: (954) 382-3486
Telefacsimile: (954) 382-5380
Designated service email:
notice@kahaneandassociates.com
File No.: 10-11338 OWB
October 12, 19, 2012 12-3947S

FIRST INSERTION

NOTICE OF SALE
IN THE CIRCUIT COURT OF THE
TWELFTH JUDICIAL CIRCUIT
IN AND FOR SARASOTA COUNTY,
FLORIDA,

CIVIL ACTION
CASE NO.: 2008 CA 009994 SC
THE BANK OF NEW YORK
MELLON F/K/A THE BANK OF
NEW YORK AS TRUSTEE FOR
THE CERTIFICATEHOLDERS
CWALT, INC. ALTERNATIVE
LOAN TRUST 2005-45
MORTGAGE PASS-THROUGH
CERTIFICATES, SERIES 2005-45,
Plaintiff vs.

DONALD BRIGGS, SR, et al.
Defendant(s)
Notice is hereby given that, pursuant to a Order Rescheduling dated September 27, 2012, entered in Civil Case Number 2008 CA 009994 SC, in the Circuit Court for Sarasota County, Florida, wherein THE BANK OF NEW YORK MELLON F/K/A THE BANK OF NEW YORK AS TRUSTEE FOR THE CERTIFICATEHOLDERS CWALT, INC. ALTERNATIVE LOAN TRUST 2005-45 MORTGAGE PASS-THROUGH CERTIFICATES, SERIES 2005-45 is the Plaintiff, and DONALD BRIGGS, SR, et al., are the Defendants, Sarasota County Clerk of Court will sell the property situated in Sarasota County, Florida, described as:

LOT 18361, 18362, AND 18363,
LESS THE SOUTH 20 FEET,
SOUTH VENICE, UNIT 69,
ACCORDING TO THE MAP
OR PLAT THEREOF, AS RECORDED IN PLAT BOOK 7,
PAGE 64, OF THE PUBLIC RECORDS OF SARASOTA COUNTY, FLORIDA

at public sale, to the highest and best bidder, for cash, at www.sarasota.realforeclose.com at 09:00 AM, on the 2nd day of November, 2012. Any person claiming an interest in the surplus from the sale, if any, other than the property owner as of the date of the lis pendens must file a claim within 60 days after the sale.

In accordance with the Americans With Disabilities Act, persons needing a reasonable accommodation to participate in this proceeding should contact the Clerk of the Circuit Court no later than seven business days prior to the proceeding at the Sarasota County Courthouse. Telephone 941-861-7425 (Sarasota and Venice) or 1-800-955-8770 via Florida Relay Service.

Dated: October 8, 2012.
By: /s/ Brad Abramson
Brad S. Abramson, Esquire
(FBN 87554)
babramson@ffaplcl.com

FLORIDA FORECLOSURE
ATTORNEYS, PLLC
601 Cleveland Street, Suite 690
Clearwater, FL 33755
(727) 446-4826
Our File No.: CA11-01179 /AA
October 12, 19, 2012 12-3945S

FIRST INSERTION

AMENDED NOTICE OF
FORECLOSURE SALE
IN THE CIRCUIT COURT IN
AND FOR SARASOTA COUNTY,
FLORIDA

CASE NO: 2007-CA-000045-SC-H
BANK OF NEW YORK
AS TRUSTEE FOR THE
CERTIFICATEHOLDERS CWALT,
INC. ALTERNATIVE LOAN
TRUST 2006-OC2 MORTGAGE
PASS-THROUGH CERTIFICATES,
SERIES 2006-OC2
Plaintiff, vs.

DAVID BOITET; UNKNOWN
TENANT I; and any unknown heirs,
devisees, grantees, creditors, and
other unknown persons or unknown
spouses claiming by, through and
under any of the above-named
Defendants,
Defendants.

NOTICE is hereby given that the Clerk of the Circuit Court of Sarasota County, Florida, will on the 5th day of November, 2012, at 9:00 a.m. www.sarasota.realforeclose.com, in accordance with Chapter 45 Florida Statutes, offer for sale and sell at public outcry to the highest and best bidder for cash, the following-described property situate in Sarasota County, Florida:

Lot 2, Block 12, FIRST ADDITION TO NORTH PORT CHARLOTTE ESTATES, according to the Plat thereof, recorded in Plat Book 19, Page 29 through 29I, of The Public Records of Sarasota County, Florida.

pursuant to the Final Judgment entered in a case pending in said Court, the style of which is indicated above.

Any person or entity claiming an interest in the surplus, if any, resulting from the foreclosure sale, other than the property owner as of the date of the Lis Pendens, must file a claim on same with the Clerk of Court within 60 days after the foreclosure sale.

In accordance with the Americans With Disabilities Act, persons needing a reasonable accommodation to participate in this proceeding should contact the Clerk of the Circuit Court no later than seven business days prior to the proceeding at the Sarasota County Courthouse. Telephone 941-861-7425 (Sarasota and Venice) or 1-800-955-8770 via Florida Relay Service.

DATED this 9th day of October, 2012.
Mikael L. Hirsch, Esquire
BUTLER & HOSCH, P.A.

3185 South Conway Road, Suite E
Orlando, Florida 32812
Telephone: (407) 381-5200
Fax: (407) 381-5577
Florida Bar No: 95601
Service Emails:
mh95601@butlerandhosch.com
FLPleadings@butlerandhosch.com
B&H # 244946
October 12, 19, 2012 12-3944S

FIRST INSERTION

NOTICE OF SALE
IN THE CIRCUIT COURT OF THE
TWELFTH JUDICIAL
CIRCUIT, IN AND FOR SARASOTA
COUNTY, FLORIDA

CASE NO. 2010 CA 006661
DEUTSCHE BANK NATIONAL
TRUST COMPANY, AS TRUSTEE
FOR ARGENT SECURITIES INC.,
ASSET-BACKED PASS-THROUGH
CERTIFICATES, SERIES 2006-W2;
Plaintiff, vs.

DOMINICA PINION A/K/A
DOMINICA PINION, ET AL;
Defendants

NOTICE IS HEREBY GIVEN that, in accordance with the Final Judgment of Foreclosure dated SEPTEMBER 24, 2012 entered in Civil Case No. 2010 CA 006661 of the Circuit Court of the TWELFTH Judicial Circuit in and for Sarasota County, Florida, wherein Deutsche Bank National Trust Company, as Trustee for Argent Securities Inc., Asset-Backed Pass-Through Certificates, Series 2006-W2, Plaintiff and DOMINICA PINION A/K/A DOMINICA PINION, MARVIN WEST PINION, DECEASED, Et Al; are defendant(s). The Clerk will sell to the highest and best bidder for cash, AT www.sarasotaclerk.com, IN ACCORDANCE WITH CHAPTER 45, FLORIDA STATUTES, AT 9:00 AM , OCTOBER 30, 2012 the following described property as set forth in said Final Judgment, to-wit:

LOT 778, UNIT 6, KENSINGTON PARK SUBDIVISION, AS PER PLAT THEREOF RECORDED IN PLAT BOOK 12, PAGES 17 AND 17A, OF PUBLIC RECORDS OF SARASOTA COUNTY, FLORIDA.

Property Address: 2401 24TH WAY, SARASOTA, FL 34235
ANY PERSON CLAIMING AN INTEREST IN THE SURPLUS FROM THE SALE, IF ANY, OTHER THAN THE PROPERTY OWNER AS OF THE DATE OF THE LIS PENDENS MUST FILE A CLAIM WITHIN 60 DAYS AFTER THE SALE.

In accordance with the Americans With Disabilities Act, persons needing a reasonable accommodation to participate in this proceeding should contact the Clerk of the Circuit Court no later than seven business days prior to the proceeding at the Sarasota County Courthouse. Telephone 941-861-7425 (Sarasota and Venice) or 1-800-955-8770 via Florida Relay Service.

By: Yahaira Velox, Esq.
FBN. 58907
MARINOSCI LAW GROUP, P.C.
Attorney for Plaintiff
100 West Cypress Creek Road,
Suite 1045
Fort Lauderdale, FL 33309
Phone: (954) 644-8704
10-04328FC
October 12, 19, 2012 12-3884S

FIRST INSERTION

NOTICE OF SALE
IN THE COUNTY COURT OF THE
TWELFTH JUDICIAL CIRCUIT
IN AND FOR SARASOTA COUNTY,
FLORIDA

CIVIL DIVISION
CASE NO. 2012 CC 003290 NC
FAIRWAY BAY ASSOCIATION,
INC., a Florida not for profit
corporation,
Plaintiff, vs.

GERARD RICCIARDELLI; DONNA
GASPARINE; WACHOVIA BANK,
N.A.; BAY ISLES ASSOCIATION,
INC; UNKNOWN TENANT #1
AND UNKNOWN TENANT #2 (as
unknown persons in possession),
Defendants.

NOTICE IS HEREBY GIVEN that, pursuant to a Final Judgment dated September 24, 2012, and entered in Case No.: 2012 CC 003290 NC of the County Court of the Twelfth Judicial Circuit in and for Sarasota County, Florida, the Clerk of the Court will sell the property situated in Sarasota County, Florida, described as:

Unit 803, Building 8, FAIRWAY BAY, PHASE 1, a condominium, according to the Declaration of Condominium thereof, as recorded in Official Records Book 1545, Page 1574, as thereafter amended, and as per Plat thereof recorded in Condominium Book 19, Page 30, as thereafter amended, of the Public Records of Sarasota County, Florida.

to the highest and best bidder for cash at HYPERLINK "http://www.sarasota.realforeclose.com" www.sarasota.realforeclose.com, at 9:00 a.m. on the 4th day of December, 2012.

ANY PERSON CLAIMING AN INTEREST IN THE SURPLUS FROM THE SALE, IF ANY, OTHER THAN THE PROPERTY OWNER AS OF THE DATE OF THE LIS PENDENS MUST FILE A CLAIM WITHIN SIXTY (60) DAYS AFTER THE SALE.

In accordance with the Americans With Disabilities Act, persons needing a reasonable accommodation to participate in this proceeding should contact the Clerk of the Circuit Court no later than seven business days prior to the proceeding at the Sarasota County Courthouse. Telephone 941-861-7425 (Sarasota and Venice) or 1-800-955-8770 via Florida Relay Service.

Dated: October 5, 2012
HANKIN, PERSSON,
MCCLLENATHEN,
COHEN & DARNELL

/s/ Kelly M. Fernandez
Kelly M. Fernandez, Esq.
Florida Bar No. 0676081
1820 Ringling Boulevard
Sarasota, FL 34236
Telephone: (941) 365-4950
Facsimile: (941) 365-3259
kfernandez@sarasotalawfirm.com
COUNSEL FOR PLAINTIFF
October 12, 19, 2012 12-3880S

FIRST INSERTION

NOTICE OF FORECLOSURE SALE
IN THE CIRCUIT COURT OF THE
12TH JUDICIAL CIRCUIT, IN
AND FOR SARASOTA COUNTY,
FLORIDA

CIVIL DIVISION
CASE NO.
2008 CA 011779 NC

RESIDENTIAL CREDIT
SOLUTIONS, INC.
Plaintiff, vs.

JOHN FERGUSON III A/K/A
JOHN EARL FERGUSON III;
SOUTH GATE COMMUNITY
ASSOCIATION, INC.; MORTGAGE
ELECTRONIC REGISTRATION
SYSTEMS, INC. AS A NOMINEE
FOR SENTINEL MORTGAGE
CO; THE HEATHROW GROUP,
LLC AS TRUSTEE OF TRUST
NUMBER 2937 PINECREST WAY;
JOHN DOE; AND JANE DOE
AS UNKNOWN TENANTS IN
POSSESSION;
Defendants.

NOTICE IS HEREBY GIVEN pursuant to a Final Judgment of Foreclosure filed September 24, 2012, and entered in Case No. 2008 CA 011779 NC, of the Circuit Court of the 12th Judicial Circuit in and for SARASOTA County, Florida. RESIDENTIAL CREDIT SOLUTIONS, INC. is Plaintiff and JOHN FERGUSON III A/K/A JOHN EARL FERGUSON III; JOHN DOE; AND JANE DOE AS UNKNOWN TENANTS IN POSSESSION; SOUTH GATE COMMUNITY ASSOCIATION, INC.; MORTGAGE ELECTRONIC REGISTRATION SYSTEMS, INC. AS A NOMINEE FOR SENTINEL MORTGAGE CO; THE HEATHROW GROUP, LLC AS TRUSTEE OF TRUST NUMBER 2937 PINECREST

WAY; are defendants. The Clerk of Court will sell to the highest and best bidder for cash by electronic sale at: www.sarasota.realforeclose.com, at 9:00 a.m., on the 29th day of October, 2012, the following described property as set forth in said Final Judgment, to wit:

LOT 15, BLOCK 106, SOUTH
GATE, UNIT NO. 25, ACCORDING TO THE PLAT
THEREOF, RECORDED IN
PLAT BOOK 9, PAGE 85
OF THE PUBLIC RECORDS
OF SARASOTA COUNTY,
FLORIDA

A person claiming an interest in the surplus from the sale, if any, other than the property owner as of the date of the lis pendens must file a claim within 60 days after the sale.

In accordance with the Americans With Disabilities Act, persons needing a reasonable accommodation to participate in this proceeding should contact the Clerk of the Circuit Court no later than seven business days prior to the proceeding at the Sarasota County Courthouse. Telephone 941-861-7425 (Sarasota and Venice) or 1-800-955-8770 via Florida Relay Service.

Dated this 8th day of October, 2012.
Stacy Robins, Esq.
Bar No.: 008079

Submitted by:
KAHANE & ASSOCIATES, P.A.
8201 Peters Road, Ste.3000
Plantation, FL 33324
Telephone: (954) 382-3486
Telefacsimile: (954) 382-5380
Designated service email:
notice@kahaneandassociates.com
File No.: 10-15074 RCS
October 12, 19, 2012 12-3948S

FIRST INSERTION

NOTICE OF FORECLOSURE SALE
IN THE CIRCUIT COURT OF THE
12TH JUDICIAL CIRCUIT, IN
AND FOR SARASOTA COUNTY,
FLORIDA

GENERAL JURISDICTION
DIVISION
CASE NO: 58-2009-CA-009270-NC

THE BANK OF NEW YORK
MELLON TRUST COMPANY, NATIONAL ASSOCIATION FKA THE
BANK OF NEW YORK TRUST
COMPANY, N.A. AS SUCCESSOR
TO JPMORGAN CHASE BANK
N.A. AS TRUSTEE FOR RAMP
2005RS2,
PLAINTIFF VS.
MARCIA C. NICHOLSON A/K/A
MARCIA HACKMAN, ET AL.,
DEFENDANT(S)

NOTICE IS HEREBY GIVEN pursuant to a Final Judgment of Foreclosure dated September 18, 2012 and entered in Case No. 58-2009-CA-009270-NC in the Circuit Court of the 12th Judicial Circuit in and for Sarasota County, Florida wherein THE BANK OF NEW YORK MELLON TRUST COMPANY, NATIONAL ASSOCIATION FKA THE BANK OF NEW YORK TRUST COMPANY, N.A. AS SUCCESSOR TO JPMORGAN CHASE BANK N.A. AS TRUSTEE FOR RAMP 2005RS2 was the Plaintiff and MARCIA C. NICHOLSON A/K/A MARCIA HACKMAN, ET AL. the Defendant(s), that the Clerk will sell to the highest and best bidder for cash, by electronic sale beginning at 9:00 a.m. on the prescribed date at www.sarasota.realforeclose.com on the 25th day of October, 2012, the following described property as set forth in said Final Judgment:

UNIT 12, PINE TREE VIL-
LAGE, A CONDOMINIUM,
ACCORDING TO THE DECLARATION OF CONDOMINIUM RECORDED IN OFFICIAL RECORD BOOK 1474, PAGES 87 THROUGH 158, INCLUSIVE, AND AS AMENDED, AND RECORDED IN CONDOMINIUM PLAT BOOK 17, PAGES 44A THRU 44L, INCLUSIVE, AND AS AMENDED, OF THE PUBLIC RECORDS OF SARASOTA COUNTY, FLORIDA.

ANY PERSON CLAIMING AN INTEREST IN THE SURPLUS FROM THE SALE, IF ANY, OTHER THAN THE PROPERTY OWNER AS OF THE DATE OF THE LIS PENDENS MUST FILE A CLAIM WITHIN SIXTY (60) DAYS AFTER THE SALE.

In accordance with the Americans With Disabilities Act, persons needing a reasonable accommodation to participate in this proceeding should contact the Clerk of the Circuit Court no later than seven business days prior to the proceeding at the Sarasota County Courthouse. Telephone 941-861-7425 (Sarasota and Venice) or 1-800-955-8770 via Florida Relay Service.

Dated this 3rd day of October, 2012
Rachelle-Marie Gentner
Florida Bar # 043967
Bus. Email: sgentner@penderlaw.com
PENDERGAST & MORGAN, P.A.
6675 Corporate Center Pkwy, Suite 301
Jacksonville, FL 32216
Telephone: 904-508-0777
PRIMARY SERVICE:
flfc@penderlaw.com
Attorney for Plaintiff
10-13254 tbs
October 12, 19, 2012 12-3889S

FIRST INSERTION

RE-NOTICE OF
FORECLOSURE SALE
IN THE CIRCUIT COURT OF THE
12TH JUDICIAL CIRCUIT, IN
AND FOR SARASOTA COUNTY,
FLORIDA

CIVIL DIVISION:
CASE NO.: 58-2010-CA-008484 NC

BAC HOME LOANS SERVICING,
LP FKA COUNTRYWIDE HOME
LOANS SERVICING L.P.,
Plaintiff, vs.

PATRICIA MERRELL; WILLIAM
MERRELL; MORTGAGE
ELECTRONIC REGISTRATION
SYSTEMS INCORPORATED,
AS A NOMINEE FOR UNITED
MEDICAL BANK, FSB; JANET
RILEY; RICHARD RILEY;
UNKNOWN TENANT (S) IN
POSSESSION OF THE SUBJECT
PROPERTY,
Defendants.

NOTICE IS HEREBY GIVEN pursuant to an Order Resetting Foreclosure Sale dated the 30th day of July, 2012, and entered in Case No. 58-2010-CA-008484 NC, of the Circuit Court of the 12TH Judicial Circuit in and for Sarasota County, Florida, wherein BAC HOME LOANS SERVICING, LP FKA COUNTRYWIDE HOME LOANS SERVICING L.P. is the Plaintiff and PATRICIA MERRELL; WILLIAM MERRELL; MORTGAGE ELECTRONIC REGISTRATION SYSTEMS INCORPORATED, AS A NOMINEE FOR UNITED MEDICAL BANK, FSB; JANET RILEY; RICHARD RILEY; UNKNOWN TENANT (S) IN POSSESSION OF THE SUBJECT PROPERTY are defendants. The Clerk of this Court shall sell to the highest and best bidder for cash electronically at www.sarasota.realforeclose.com at, 9:00 AM on the

29th day of October, 2012, the following described property as set forth in said Final Judgment, to wit:

LOTS 30 AND 31, BLOCK A,
HOLIDAY HARBOR, UNIT 1,
A SUBDIVISION ACCORDING TO THE PLAT OR MAP THEREOF AS RECORDED IN PLAT BOOK 7, PAGE 67, OF THE PUBLIC RECORDS OF SARASOTA COUNTY, FLORIDA.

ANY PERSON CLAIMING AN INTEREST IN THE SURPLUS FROM THE SALE, IF ANY, OTHER THAN THE PROPERTY OWNER AS OF THE DATE OF THE LIS PENDENS MUST FILE A CLAIM WITHIN 60 DAYS AFTER THE SALE.

In accordance with the Americans With Disabilities Act, persons needing a reasonable accommodation to participate in this proceeding should contact the Clerk of the Circuit Court no later than seven business days prior to the proceeding at the Sarasota County Courthouse. Telephone 941-861-7425 (Sarasota and Venice) or 1-800-955-8770 via Florida Relay Service.

Dated this 5 day of October, 2012.
By: Elisabeth Porter, Esq.
Bar Number: 645648

LAW OFFICES OF
MARSHALL C. WATSON, P.A.
1800 NW 49th Street, Suite 120
Fort Lauderdale, Florida 33309
Telephone: (954) 453-0365
Facsimile: (954) 771-6052
Toll Free: 1-800-441-2438
DESIGNATED PRIMARY E-MAIL
FOR SERVICE PURSUANT TO FLA.
R. JUD. ADMIN 2.516
eservice@marshallwatson.com
10-03609
October 12, 19, 2012 12-3952S

SUBSCRIBE TO
GULF COAST Business Review
Call: (941) 362-4848 or go to: www.review.net
GULF COAST Business Review
www.review.net

FIRST INSERTION

NOTICE OF SALE
IN THE CIRCUIT COURT OF THE
12TH JUDICIAL CIRCUIT
IN AND FOR SARASOTA COUNTY,
FLORIDA

CIRCUIT CIVIL DIVISION
Case No.: 2010-CA-006989-NC
Division: Civil Circuit C
NORTHERN TRUST, NATIONAL
ASSOCIATION, etc.,
Plaintiff, vs.
JANINE Y. GRIFFIN, DEVONTE
BAILEY, CITY OF SARASOTA,
Defendant.

NOTICE IS GIVEN that pursuant to that certain Final Judgment, dated June 11, 2012, as amended by court orders entered on August 20, 2012 and on October 2, 2012, in Case No. 2010-CA-006989-NC of the Circuit Court of the 12th Judicial Circuit in and for Sarasota County, Florida, wherein NORTHERN TRUST, NATIONAL ASSOCIATION, FORMERLY KNOWN AS NORTHERN TRUST BANK OF FLORIDA NATIONAL ASSOCIATION, is the Plaintiff and JANINE Y. GRIFFIN, UNKNOWN TENANT N/K/A DEVONTE BAILEY, and CITY OF SARASOTA, a Municipal Corporation, are the Defendants, the HON. KAREN E. RUSHING, Clerk of the Court, Sarasota County, Florida will sell the property located in Sarasota County, Florida to the highest and best bidder for cash.

This foreclosure sale will be conducted via Internet at www.sarasota.realforeclose.com at 9:00 am, on November 6, 2012, the following described property set forth in the Order of Final Judgment:

LOT 27, BLOCK 653, 14th ADDITION TO PORT CHARLOTTE SUBDIVISION, ACCORDING TO THE PLAT THEREOF, RECORDED IN PLAT BOOK 13, PAGE 13 OF THE PUBLIC RECORDS OF SARASOTA COUNTY, FLORIDA.

Property Address: 3200 Duar Terrace, North Port, FL 34291

Tax Collector Account Number: 0969-06-5327

Any person claiming an interest in the surplus from the sale, if any, other than the property owner as of the date of the lis pendens must file a claim within 60 days after the sale.

In accordance with the Americans With Disabilities Act, persons needing a reasonable accommodation to participate in this proceeding should contact the Clerk of the Circuit Court no later than seven business days prior to the proceeding at the Sarasota County Courthouse. Telephone 941-861-7425 (Sarasota and Venice) or 1-800-955-8770 via Florida Relay Service.

DATED: October 3, 2012
By: James W. Devine 71007
Steven M. Lee, Esq.,
Attorney for Plaintiff
Florida Bar No. 709603

STEVEN M. LEE, P.A.
Lee Professional Building
1200 SW 2nd Avenue
Miami, Florida 33130-4214
305-856-7855 phone
305-856-7877 fax
October 12, 19, 2012 12-3883S

FIRST INSERTION

NOTICE OF RESCHEDULED
FORECLOSURE SALE
IN THE CIRCUIT COURT OF THE
TWELFTH JUDICIAL CIRCUIT
IN AND FOR SARASOTA COUNTY,
FLORIDA

CIVIL ACTION
Case No.: 2009 CA 014830 NC
DIVISION: A
BAC HOME LOANS SERVICING,
LP F/K/A COUNTRYWIDE HOME
LOANS SERVICING, L.P.,
Plaintiff, vs.
LISA MOWREY, et al,
Defendant(s).

NOTICE IS HEREBY GIVEN pursuant to an Order Rescheduling Foreclosure Sale dated October 3, 2012 and entered in Case No. 2009 CA 014830 NC of the Circuit Court of the TWELFTH Judicial Circuit in and for Sarasota County, Florida wherein BAC HOME LOANS SERVICING, LP F/K/A COUNTRYWIDE HOME LOANS SERVICING, L.P., is the Plaintiff and LISA MOWREY; SEA CLUB II HOMEOWNERS ASSOCIATION, INC.; are the Defendants, The Clerk will sell to the highest and best bidder for cash at WWW.SARASOTA.REALFORECLOSE.COM at 9:00AM, on 11/06/2012, the following described property as set forth in said Final Judgment:

UNIT 11-E, CONTINENTALS SEA CLUB 2, PHASE I, A CONDOMINIUM, ACCORDING TO THE DECLARATION OF CONDOMINIUM RECORDED IN OFFICIAL RECORDS BOOK 1233, PAGES 73 THROUGH 123 AND AMENDMENTS THERETO AND AS PER PLAT THEREOF, RECORDED IN CONDOMINIUM BOOK 10, PAGES 43, 43A THROUGH 43C AND AMENDMENTS THERETO, PUBLIC RECORDS OF SARASOTA COUNTY, FLORIDA. TOGETHER WITH AN UNDIVIDED INTEREST IN THE COMMON ELEMENTS APPURTENANT THERETO AS SET FORTH IN SAID DECLARATION

A/K/A 5955 MIDNIGHT PASS
ROADD UNIT #11E, SARASOTA, FL 34242

Any person claiming an interest in the surplus from the sale, if any, other than the property owner as of the date of the Lis Pendens must file a claim within sixty (60) days after the sale.

In accordance with the Americans With Disabilities Act, persons needing a reasonable accommodation to participate in this proceeding should contact the Clerk of the Circuit Court no later than seven business days prior to the proceeding at the Sarasota County Courthouse. Telephone 941-861-7425 (Sarasota and Venice) or 1-800-955-8770 via Florida Relay Service.

By: Sabrina M. Moravecky
Florida Bar No. 44669
RONALD R WOLFE &
ASSOCIATES, P.L.
P.O. Box 25018
Tampa, Florida 33622-5018
(813) 251-4766
F09079529
October 12, 19, 2012 12-3963S

FIRST INSERTION

NOTICE OF SALE
IN THE COUNTY COURT OF THE
TWELFTH JUDICIAL CIRCUIT IN
AND FOR SARASOTA COUNTY,
FLORIDA

CIVIL ACTION
Case No. 2012 CC 000248 NC
SARASOTA SANDS OWNER'S
ASSOCIATION, INC.,
Plaintiff, vs.
MELVIN B. LOHR and
KATHERINE E. LOHR,
Defendants.

NOTICE is given that pursuant to the Final Judgment of Foreclosure and Damages entered in the above noted case, that I will sell the following property situated in Sarasota County, Florida described as:

Undivided 1/50th interest in and to Condominium Unit E 454/455, Week 35 and their undivided respective share in those common elements appertaining thereto in accordance with and subject to the covenants, conditions, terms, restrictions and other provisions of a certain Declaration of Condominium of SARASOTA SANDS, a resort condominium hotel, as recorded in Official Records Book 1364 at Page 1165 et seq. of the public records of Sarasota County, Florida, and as per Condominium Plat recorded in Condominium Book 14 at Pages 4 through 4B inclusive of the public records of Sarasota County, Florida

at public sale, to the highest and best bidder for cash, via the internet at www.sarasota.realforeclose.com at 9:00 a.m. on November 9, 2012. The highest bidder shall immediately post with the Clerk, a deposit equal to 5% of the final bid. The deposit must be cash or cashier's check payable to the Clerk of the Circuit Court. Final payment must be made on or before 5:00 p.m. of the date of the sale by cash or cashier's check.

IF YOU ARE A PERSON CLAIMING A RIGHT TO FUNDS REMAINING AFTER THE SALE, YOU MUST FILE A CLAIM WITH THE CLERK NO LATER THAN 60 DAYS AFTER THE SALE. IF YOU FAIL TO FILE A CLAIM, YOU WILL NOT BE ENTITLED TO ANY REMAINING FUNDS AFTER 60 DAYS, ONLY THE OWNER OF RECORD AS OF THE DATE OF THE LIS PENDENS MAY CLAIM THE SURPLUS.

In accordance with the Americans With Disabilities Act, persons needing a reasonable accommodation to participate in this proceeding should contact the Clerk of the Circuit Court no later than seven business days prior to the proceeding at the Sarasota County Courthouse. Telephone 941-861-7425 (Sarasota and Venice) or 1-800-955-8770 via Florida Relay Service.

DAVID K. OAKS, ESQ.,
DAVID K. OAKS, P.A.
407 E. Marion Avenue, Suite 101
Punta Gorda, FL 33950
Attorney for the Plaintiff
Florida Bar No. 0301817
Telephone: 941-639-7627
Fax: 941-575-0242
email: doakseq@comcast.net
October 12, 19, 2012 12-3951S

FIRST INSERTION

NOTICE OF FORECLOSURE SALE
IN THE CIRCUIT COURT OF THE
TWELFTH JUDICIAL CIRCUIT OF
FLORIDA IN AND FOR SARASOTA
COUNTY

GENERAL JURISDICTION
DIVISION
CASE NO. 2008-CA-015150 NC
BANK OF AMERICA, N.A. AS
SUCCESSOR BY MERGER TO
BAC HOME LOANS SERVICING,
LP F/K/A COUNTRYWIDE HOME
LOANS SERVICING, LP,
Plaintiff, vs.
FRED A. MINTON, et al.,
Defendants.

NOTICE IS HEREBY GIVEN pursuant to a Summary Final Judgment of Foreclosure filed on July 24, 2012 entered in Civil Case No. 2008-CA-015150 NC of the Circuit Court of the TWELFTH Judicial Circuit in and for Sarasota County, Sarasota, Florida, wherein Bank of America, N.A. As Successor By Merger to BAC Home Loans Servicing, LP F/K/A Countrywide Home Loans Servicing, LP is the Plaintiff and FRED A. MINTON, are the Defendants. The Clerk of Court will sell to the highest and best bidder for cash electronically at www.sarasota.realforeclose.com in accordance with Chapter 45, Florida Statutes on the 23rd day of October, 2012 at 09:00 AM on the following described property as set forth in said Summary Final Judgment, to-wit:

Unit 1602, of Fairway Woods Section One, a condominium, together with an undivided interest in the common elements appurtenant thereto, according to the Declaration of Condominium thereof, as recorded in Official Records Book 1765, at Pages 1634 through 1704, inclusive, and as per plat recorded in Condominium Plat Book 24, Page 13, of the Public Records of Sarasota County, Florida, Together with any amendments thereof.

Any person claiming an interest in the surplus from the sale, if any, other than the property owner as of the date of the lis pendens, must file a claim within 60 days after the sale.

In accordance with the Americans With Disabilities Act, persons needing a reasonable accommodation to participate in this proceeding should contact the Clerk of the Circuit Court no later than seven business days prior to the proceeding at the Sarasota County Courthouse. Telephone 941-861-7425 (Sarasota and Venice) or 1-800-955-8770 via Florida Relay Service.

I HEREBY CERTIFY that a true and correct copy of the foregoing was Mailed this 4th day of October 2012, to all parties on the attached service list.

Allyson G Morgado
FL Bar # 91506
Nicholas J. Vanhook, Esq.
Florida Bar No.: 0037881
McCALLA RAYMER, LLC
ATTORNEYS FOR PLAINTIFF
225 East Robinson Street, Suite 660
Orlando, FL 32801
Phone: (407) 674-1850
Fax: (321) 248-0420
757822
10-01496-5
October 12, 19, 2012 12-3885S

FIRST INSERTION

NOTICE OF FORECLOSURE SALE
IN THE CIRCUIT COURT OF THE
12TH JUDICIAL CIRCUIT, IN
AND FOR SARASOTA COUNTY,
FLORIDA

CIVIL DIVISION
CASE NO. 2008 CA 016979 NC
BANKUNITED, FSB
Plaintiff, vs.
RAY W. SIMMERS; et al.,
Defendants.

NOTICE IS HEREBY GIVEN pursuant to a Final Judgment of Foreclosure filed July 31, 2012, and entered in Case No. 2008 CA 016979 NC, of the Circuit Court of the 12th Judicial Circuit in and for SARASOTA County, Florida. BANKUNITED, FSB is Plaintiff and RAY W. SIMMERS; NANCY ELIZABETH SIMMERS; JOHN DOE N/K/A MICHAEL CLARK; MARY DOE N/K/A DEVON CLARK AND/OR ALL OTHERS WHOM IT MAY CONCERN; GALAXY CHEMICAL CORPORATION D/B/A GALAXY POOLS, A FLORIDA PROFIT CORPORATION; LAS PALMAS OF SARASOTA CONDOMINIUM ASSOCIATION INC., A FLORIDA NON-PROFIT CORPORATION; are defendants. The Clerk of Court will sell to the highest and best bidder for cash by electronic sale at: www.sarasota.realforeclose.com, at 9:00 a.m., on the 29th day of October, 2012, the following described property as set forth in said Final Judgment, to wit:

UNIT 202, BLDG3, LAS PALMAS OF SARASOTA, A LUXURY CONDOMINIUM, ACCORDING TO THE DECLARATION OF CONDOMINIUM, THEREOF RECORDED IN OFFICIAL RECORDS INSTRUMENT #2004247846, AS AMENDED IN OFFICIAL RECORDS INSTRUMENT #2004247847, PUBLIC RECORDS OF SARASOTA COUNTY FLORIDA.

A person claiming an interest in the surplus from the sale, if any, other than the property owner as of the date of the lis pendens must file a claim within 60 days after the sale.

In accordance with the Americans With Disabilities Act, persons needing a reasonable accommodation to participate in this proceeding should contact the Clerk of the Circuit Court no later than seven business days prior to the proceeding at the Sarasota County Courthouse. Telephone 941-861-7425 (Sarasota and Venice) or 1-800-955-8770 via Florida Relay Service.

Dated this 8th day of October, 2012.
Stacy Robins, Esq.
Bar No.: 008079

Submitted by:
KAHANE & ASSOCIATES, P.A.
8201 Peters Road, Ste.3000
Plantation, FL 33324
Telephone: (954) 382-3486
Telefacsimile: (954) 382-5380
Designated service email:
notice@kahaneandassociates.com
File No.: 09-29908 BU
October 12, 19, 2012 12-3946S

FIRST INSERTION

NOTICE OF FORECLOSURE SALE
IN THE CIRCUIT COURT OF THE
TWELFTH JUDICIAL CIRCUIT IN
AND FOR SARASOTA COUNTY,
FLORIDA

GENERAL JURISDICTION
DIVISION
CASE NO. 2012 CA 003518 NC
THE BANK OF NEW YORK
MELLON F/K/A THE BANK
OF NEW YORK, AS TRUSTEE
FOR THE HOLDERS OF THE
CERTIFICATES, FIRST HORIZON

MORTGAGE PASS-THROUGH
CERTIFICATES SERIES FHAMS
2006-AA4, BY FIRST HORIZON
HOME LOANS, A DIVISION
OF FIRST TENNESSEE BANK
NATIONAL ASSOCIATION,
MASTER SERVICER, IN ITS
CAPACITY AS AGENT FOR THE
TRUSTEE UNDER THE POOLING
AND SERVICING AGREEMENT,
Plaintiff, vs.
HECTOR A. GOMEZ A/K/A
HECTOR GOMEZ, et al.
Defendant.

NOTICE IS HEREBY GIVEN pursuant to a Final Judgment of Foreclosure dated AUGUST 16, 2012, and entered in 2012 CA 003518 NC of the Circuit Court of the Twelfth Judicial Circuit in and for Sarasota County, Florida, wherein THE BANK OF NEW YORK MELLON F/K/A THE BANK OF NEW YORK, AS TRUSTEE FOR THE HOLDERS OF THE CERTIFICATES, FIRST HORIZON MORTGAGE PASS-THROUGH CERTIFICATES SERIES FHAMS 2006-AA4, BY FIRST HORIZON HOME LOANS, A DIVISION OF FIRST TENNESSEE BANK NATIONAL ASSOCIATION, MASTER SERVICER, IN ITS CAPACITY AS AGENT FOR THE TRUSTEE UNDER THE POOLING AND SERVICING AGREEMENT, is the Plaintiff and HECTOR A. GOMEZ A/K/A HECTOR GOMEZ; UNKNOWN SPOUSE OF HECTOR A. GOMEZ A/K/A HECTOR GOMEZ N/K/A DAISEY GOMEZ; MORT-

FIRST INSERTION

NOTICE OF FORECLOSURE SALE
IN THE CIRCUIT COURT OF THE
12TH JUDICIAL CIRCUIT, IN
AND FOR SARASOTA COUNTY,
FLORIDA

GENERAL JURISDICTION
DIVISION
CASE NO: 58-2009-CA-011829-NC
THE BANK OF NEW YORK
MELLON TRUST COMPANY,
NATIONAL ASSOCIATION FKA
THE BANK OF NEW YORK TRUST
COMPANY, N.A. AS SUCCESSOR
TO JPMORGAN CHASE BANK
N.A. AS TRUSTEE FOR RAMP
2005RSS,
PLAINTIFF VS.
LOIS C. WINKLER, ET AL.,
DEFENDANT(S)

NOTICE IS HEREBY GIVEN pursuant to a Final Judgment of Foreclosure dated September 18, 2012 and entered in Case No. 58-2009-CA-011829-NC in the Circuit Court of the 12th Judicial Circuit in and for Sarasota County, Florida wherein THE BANK OF NEW YORK MELLON TRUST COMPANY, NATIONAL ASSOCIATION FKA THE BANK OF NEW YORK TRUST COMPANY, N.A. AS SUCCESSOR TO JPMORGAN CHASE BANK N.A. AS TRUSTEE FOR RAMP 2005RSS was the Plaintiff and LOIS C. WINKLER, ET AL. the Defendant(s), that the Clerk will sell to the highest and best bidder for cash, by electronic sale beginning at 9:00 a.m. on the prescribed date at www.sarasota.realforeclose.com on the 25th day of October, 2012, the following described property as set forth in said Final Judgment:

LOT 1399 AND 1400, OF LAKE SARASOTA, UNIT 15, ACCORDING TO THE PLAT THEREOF, AS RECORDED IN PLAT BOOK 9, AT PAGE(S) 21, OF THE PUBLIC RECORDS OF SARASOTA COUNTY, FLORIDA.

ANY PERSON CLAIMING AN INTEREST IN THE SURPLUS FROM THE SALE, IF ANY, OTHER THAN THE PROPERTY OWNER AS OF THE DATE OF THE LIS PENDENS MUST FILE A CLAIM WITHIN SIXTY (60) DAYS AFTER THE SALE.

In accordance with the Americans With Disabilities Act, persons needing a reasonable accommodation to participate in this proceeding should contact the Clerk of the Circuit Court no later than seven business days prior to the proceeding at the Sarasota County Courthouse. Telephone 941-861-7425 (Sarasota and Venice) or 1-800-955-8770 via Florida Relay Service.

Dated this 3rd day of October, 2012
Rachelle-Marie Gentner
Florida Bar # 043967
Bus. Email: sgentner@penderlaw.com
PENDERGAST & MORGAN, P.A.
6675 Corporate Center Pkwy, Suite 301
Jacksonville, FL 32216
Telephone: 904-508-0777
PRIMARY SERVICE:
flfc@penderlaw.com
Attorney for Plaintiff
10-13522 tbs
October 12, 19, 2012 12-3890S

FIRST INSERTION

NOTICE OF FORECLOSURE SALE
IN THE CIRCUIT COURT OF THE
TWELFTH JUDICIAL CIRCUIT, IN
AND FOR SARASOTA COUNTY,
FLORIDA

CIVIL ACTION
CASE NO.: 2008-CA-017037-NC
DIVISION: C
DEUTSCHE BANK TRUST
COMPANY AMERICAS AS
TRUSTEE FOR RALI 2005QA8,
Plaintiff, vs.
HANI RIHAN AS TRUSTEE OF
THE HANI RIHAN LIVING TRUST
UNDER TRUST AGREEMENT
DATED OCTOBER 11, 2007, et al.,
Defendant(s).

NOTICE IS HEREBY GIVEN pursuant to a Final Judgment of Mortgage Foreclosure dated August 6, 2012 and entered in Case No. 2008-CA-017037-NC of the Circuit Court of the TWELFTH Judicial Circuit in and for SARASOTA County, Florida wherein DEUTSCHE BANK TRUST COMPANY AMERICAS AS TRUSTEE FOR RALI 2005QA8 is the Plaintiff and HANI RIHAN AS TRUSTEE OF THE HANI RIHAN LIVING TRUST UNDER TRUST AGREEMENT DATED OCTOBER 11, 2007; THE UNKNOWN BENEFICIARIES OF THE HANI RIHAN LIVING TRUST UNDER TRUST AGREEMENT DATED OCTOBER 11, 2007; HANI RIHAN; JAMES CULMONE; ANY AND ALL UNKNOWN PARTIES CLAIMING BY, THROUGH, UNDER, AND AGAINST THE HEREIN NAMED INDIVIDUAL DEFENDANT(S) WHO ARE NOT KNOWN TO BE DEAD OR ALIVE, WHETHER SAID UNKNOWN

PARTIES MAY CLAIM AN INTEREST AS SPOUSE, HEIRS, DEVISEES, GRANTEES, OR OTHER CLAIMANTS; NATIONAL CITY BANK; are the Defendants, The Clerk will sell to the highest and best bidder for cash at WWW.SARASOTA.REALFORECLOSE.COM at 9:00AM, on the 2nd day of November, 2012, the following described property as set forth in said Final Judgment:

LOT 1 AND THE NORTHERLY 15 FEET OF LOT 2, BLOCK 27, SARASOTA BEACH, ACCORDING TO THE PLAT THEREOF AS RECORDED IN PLAT BOOK 1, PAGE(S) 76-81, INCLUSIVE, OF THE PUBLIC RECORDS OF SARASOTA COUNTY, FLORIDA

A/K/A 646 CANAL ROAD,
SARASOTA, FL 34242

Any person claiming an interest in the surplus from the sale, if any, other than the property owner as of the date of the Lis Pendens must file a claim within sixty (60) days after the sale.

In accordance with the Americans With Disabilities Act, persons needing a reasonable accommodation to participate in this proceeding should contact the Clerk of the Circuit Court no later than seven business days prior to the proceeding at the Sarasota County Courthouse. Telephone 941-861-7425 (Sarasota and Venice) or 1-800-955-8770 via Florida Relay Service.

By: Ashleigh L. Price
Florida Bar No. 51416
RONALD R WOLFE &
ASSOCIATES, P.L.
P.O. Box 25018
Tampa, Florida 33622-5018
(813) 251-4766
F08089014
October 12, 19, 2012 12-3898S

FIRST INSERTION

AMENDED NOTICE OF ACTION
IN THE COUNTY COURT OF THE
TWELFTH JUDICIAL CIRCUIT IN
AND FOR SARASOTA COUNTY,
FLORIDA

CIVIL ACTION
Case No. 2011 CC 007709 NC
SARASOTA SANDS OWNERS
ASSOCIATION, INC.,
Plaintiff, vs.
JEAN MCGILL CASE,
TRUSTEE OF THE JEAN MCGILL
CASE REVOCABLE TRUST
AGREEMENT dated December 23,
1991 and the unknown heirs and
beneficiaries of JEAN MCGILL
CASE, deceased.
Defendants.

TO: JEAN MCGILL CASE, TRUSTEE OF THE JEAN MCGILL CASE REVOCABLE TRUST AGREEMENT dated December 23, 1991 and the unknown heirs and beneficiaries of JEAN MCGILL CASE, deceased, and if any of the above named natural persons be married, their unknown spouses, and if any of the above named natural persons to be dead, their unknown heirs, devisees, grantees, successors or other parties claiming by, through, under or against them, and any and all other persons claiming any right, title, interest, lien, estate or demand in or to be the following described real property and to reform a certain deed, situate, lying and being in Sarasota County, Florida, to-wit:

An undivided 1/50th interest in and to Condominium Unit B 238, Week 27 and their undivided respective share in those common elements appertaining thereto in accordance with and subject to the covenants, conditions, terms, restrictions and other provisions of a certain Declaration of Condominium of SARASOTA SANDS, a resort condominium hotel, as recorded in Official Records Book 1364 at

Page 1165 et seq. of the public records of Sarasota County, Florida, and as per Condominium Plat recorded in Condominium Book 14 at Pages 4 through 4B, inclusive of the public records of Sarasota County, Florida

YOU ARE HEREBY notified that a foreclosure action on the above described property has been filed against you in the above entitled Court and you are required to serve a copy of your written defenses to the Complaint on the Plaintiff's Attorney, DAVID K. OAKS, ESQ., of DAVID K. OAKS, P.A., 407 East Marion Avenue, Suite 101, Punta Gorda, Florida, 33950, and file the original with the Clerk of the Court, Sarasota County Justice Center, 2000 Marion Street, Sarasota, FL 34237 on or before the 11 day of November, 2012, otherwise a judgment may be entered against you for the relief demanded in the Complaint.

In accordance with the Americans With Disabilities Act, persons needing a reasonable accommodation to participate in this proceeding should contact the Clerk of the Circuit Court no later than seven business days prior to the proceeding at the Sarasota County Courthouse. Telephone 941-861-7425 (Sarasota and Venice) or 1-800-955-8770 via Florida Relay Service.

Witness my hand and seal of said Court on this 3 day of October, 2012.

KAREN E. RUSHING
Clerk of the Court
BY G. Kopinsky
Deputy Clerk
DAVID K. OAKS, ESQ.
DAVID K. OAKS, P.A.
407 E. Marion Avenue, Suite 101
Punta Gorda, FL 33950
Attorney for the Plaintiff
Telephone: 941-639-7627
Fax: 941-575-0242
October 12, 19, 2012 12-3887S

FIRST INSERTION

NOTICE OF ACTION
IN THE CIRCUIT COURT
FOR THE TWELFTH JUDICIAL
CIRCUIT IN AND FOR SARASOTA
COUNTY, FLORIDA
CIVIL DIVISION

Case No.: 2012 CA 007117 NC
CITY OF SARASOTA, FLORIDA,
a municipal corporation,
Plaintiff, v.
PAULA R. READY; ROBERT C.
READY; DIANA R. READY;
BANK OF AMERICA, N.A.;
AND EMPIRIAN PROPERTY
MANAGEMENT, INC.,
Defendants

TO: PAULA R. READY
The names of the known natural
Defendants are Paula R. Ready; Robert C.
Ready, and Diana R. Ready. The corporate
Defendants are Bank of America,
N.A.; and Empirian Property Manage-
ment, Inc. There are no unknown De-
fendants in this action

A Complaint has been filed to fore-
close code compliance liens against cer-
tain real property in Sarasota County,
Florida. The Complaint has been filed
in the Circuit Court of the Twelfth
Judicial Circuit in and for Sarasota
County, Florida. The action is styled
City of Sarasota, Florida versus Paula
R. Ready, et als.

The real property which Plaintiff,
City of Sarasota, Florida seeks to fore-
close is the following:

The East 80 feet of the West
98.6 feet of the South 1/2 of Lot
27, Block A, BELLEVUE TER-
RACE, as per Plat thereof re-
corded in Plat Book 1, Page 30
of the Public Records of Sarasota
County, Florida.

This is Parcel ID No. 0054-06-
0055 located at 3049 Browning
Street, Sarasota, Florida 34237.

Each Defendant is required to serve
written defenses to the Complaint on
Plaintiff's attorney Michael A. Connolly
at Fournier, Connolly, Warren & Sham-
sey, P.A., 1 South School Avenue, Suite
700, Sarasota, Florida 34237 on or be-
fore the 12th day of November, 2012;
and to file the original of the defense
with the Clerk of Circuit Court either
before service on the Plaintiff's attor-
ney or immediately thereafter, show-
ing what right, title, interest or lien the
Defendant has in or to the property de-
scribed above. If any Defendant fails to
do so, a default will be entered against
that Defendant for the relief demanded
in the Complaint.

WITNESS my hand and the seal of
this Court on this 2nd day of October,
2012.

KAREN E. RUSHING
Clerk of Circuit Court
(SEAL) By: Eva Olivia
Deputy Clerk

Plaintiff's Attorney
MICHAEL A. CONNOLLY
FOURNIER AND CONNOLLY, P.A.
1 South School Avenue, Suite 700
Sarasota, Florida 34237
October 12, 19, 26;
November 2, 2012 12-3877S

FIRST INSERTION

NOTICE OF ACTION
IN THE CIRCUIT COURT OF THE
TWELFTH JUDICIAL CIRCUIT IN
AND FOR SARASOTA COUNTY,
FLORIDA
CIVIL ACTION

CASE NO.: 2012 CA 001540 NC
CITIMORTGAGE, INC.,
Plaintiff, vs.
JEREMY R. BETTIS, et al,
Defendant(s).

To: JEREMY R. BETTIS
Last Known Address:
4241 Santo Avenue
Sarasota, FL 34241
Current Address: Unknown
ANY AND ALL UNKNOWN PAR-
TIES CLAIMING BY, THROUGH,
UNDER, AND AGAINST THE
HEREIN NAMED INDIVIDUAL
DEFENDANT(S) WHO ARE NOT
KNOWN TO BE DEAD OR ALIVE,
WHETHER SAID UNKNOWN PAR-
TIES MAY CLAIM AN INTEREST
AS SPOUSES, HEIRS, DEVISEES,
GRANTEES, OR OTHER CLAIM-
ANTS

Last Known Address: Unknown
Current Address: Unknown
YOU ARE NOTIFIED that an action
to foreclose a mortgage on the following
property in Sarasota County, Florida:
LOT 123, LAKE SARASOTA,
UNIT NO. 2, ACCORDING
TO THE PLAT THEREOF, AS
RECORDED IN PLAT BOOK
8, PAGE 65, OF THE PUBLIC
RECORDS OF SARASOTA
COUNTY, FLORIDA.

A/K/A 4241 SANTO AVENUE,
SARASOTA, FL 34241

has been filed against you and you are
required to serve a copy of your writ-
ten defenses within 30 days after the
first publication, if any, on Albertelli
Law, Plaintiff's attorney, whose ad-
dress is P.O. Box 23028, Tampa, FL
33623, and file the original with this
Court either before service on Plain-
tiff's attorney, or immediately there-
after; otherwise, a default will be
entered against you for the relief de-
manded in the Complaint or petition.

This notice shall be published once a
week for two consecutive weeks in the
Gulf Coast Business Review.

In accordance with the Americans
With Disabilities Act, persons needing
a reasonable accommodation to par-
ticipate in this proceeding should con-
tact the Clerk of the Circuit Court no
later than seven business days prior to
the proceeding at the Sarasota County
Courthouse. Telephone 941-861-7425
(Sarasota and Venice) or 1-800-955-
8770 via Florida Relay Service.

WITNESS my hand and the seal of
this court on this 4 day of October,
2012.

KAREN E. RUSHING, CLERK
Clerk of the Circuit Court
(SEAL) By: M. Foulks
Deputy Clerk

ALBERTELLI LAW
P.O. Box 23028
Tampa, FL 33623
11-92583
October 12, 19, 2012 12-3874S

FIRST INSERTION

NOTICE OF ACTION
IN THE CIRCUIT COURT OF THE
TWELFTH JUDICIAL CIRCUIT OF
THE STATE OF FLORIDA, IN AND
FOR SARASOTA COUNTY
CIVIL DIVISION

CASE NO. 2012 CA 003121 NC
BANK OF AMERICA, N.A. AS
SUCCESSOR BY MERGER TO
BAC HOME LOANS SERVICING,
LP F/K/A COUNTRYWIDE HOME
LOANS SERVICING, LP,
Plaintiff, vs.

GALINA KALEVA A/K/A
GALINA M. KALEVA;
UNKNOWN SPOUSE OF
GALINA KALEVA A/K/A
GALINA M. KALEVA;
DIMITAR IVANOV KALEV;
IF LIVING, INCLUDING ANY
UNKNOWN SPOUSE OF SAID
DEFENDANT(S), IF REMARRIED,
AND IF DECEASED, THE
RESPECTIVE UNKNOWN HEIRS,
DEVISEES, GRANTEEES,
ASSIGNEES, CREDITORS,
LIENORS, AND TRUSTEES, AND
ALL OTHER PERSONS
CLAIMING BY, THROUGH,
UNDER OR AGAINST THE
NAMED DEFENDANT(S); CITY
OF SARASOTA, A MUNICIPAL
CORPORATION OF THIS
STATE OF FLORIDA; BANK OF
AMERICA, N.A.; WHETHER
DISSOLVED OR PRESENTLY
EXISTING, TOGETHER WITH
ANY GRANTEEES, ASSIGNEES,
CREDITORS, LIENORS,
OR TRUSTEES OF SAID
DEFENDANT(S) AND ALL
OTHER PERSONS CLAIMING
BY, THROUGH, UNDER, OR
AGAINST DEFENDANT(S);
UNKNOWN TENANT #1;
UNKNOWN TENANT #2;
Defendant(s)

TO: GALINA KALEVA A/K/A GALI-
NA M. KALEVA
Whose residence(s) is/are unknown.

YOU ARE HEREBY required to
file your answer or written defenses, if
any, in the above proceeding with the

Clerk of this Court, and to serve a copy
thereof upon the plaintiff's attorney,
Law Offices of Daniel C. Consuegra,
9204 King Palm Drive, Tampa, FL
33619-1328, telephone (813) 915-8660,
facsimile (813) 915-0559, within thirty
days of the first publication of this No-
tice, the nature of this proceeding being
a suit for foreclosure of mortgage
against the following described prop-
erty, to wit:

Lot 320, RIDGEWOOD ES-
TATES 1ST ADDITION, ac-
cording to the plat thereof, as
recorded in Plat Book 12, Page
5, of the Public Records of Sara-
sota County, Florida.

If you fail to file your response or an-
swer, if any, in the above proceeding
with the Clerk of this Court, and to
serve a copy thereof upon the plain-
tiff's attorney, Law Offices of Daniel
C. Consuegra, 9204 King Palm Drive,
Tampa, Florida 33619-1328, telephone
(813) 915-8660, facsimile (813) 915-
0559, within thirty days of the first
publication of this Notice, a default will
be entered against you for the relief de-
manded in the Complaint or Petition.

In accordance with the Americans
With Disabilities Act, persons needing
a reasonable accommodation to par-
ticipate in this proceeding should con-
tact the Clerk of the Circuit Court no
later than seven business days prior to
the proceeding at the Sarasota County
Courthouse. Telephone 941-861-7425
(Sarasota and Venice) or 1-800-955-
8770 via Florida Relay Service.

DATED at SARASOTA County this 1
day of October, 2012.

KAREN E. RUSHING, CLERK
Clerk of the Circuit Court
(SEAL) By M. Foulks
Deputy Clerk

LAW OFFICES OF
DANIEL C. CONSUEGRA
9204 King Palm Drive
Tampa, FL 33619-1328
Telephone (813) 915-8660
Facsimile (813) 915-0559
October 12, 19, 2012 12-3875S

FIRST INSERTION

NOTICE OF SALE
IN THE COUNTY COURT OF THE
TWELFTH JUDICIAL CIRCUIT
IN AND FOR SARASOTA COUNTY,
FLORIDA

CIVIL DIVISION
CASE NO. 2012 CC 003211 NC
KANAYA CONDOMINIUM
ASSOCIATION, INC., a Florida not
for profit corporation,
Plaintiff, vs.

PETER J. JAENSCH; CHERI A.
JAENSCH; and IBERIABANK,
Defendants.

NOTICE IS HEREBY GIVEN that,
pursuant to a Final Judgment dated
October 1, 2012, and entered in Case
No.: 2012 CC 003211 NC of the County
Court of the Twelfth Judicial Circuit in
and for Sarasota County, Florida, the
Clerk of the Court will sell the property
situated in Sarasota County, Florida,
described as:

Unit 603, KANAYA, a condo-
minium, according to the Decla-
ration of Condominium thereof,
as recorded in Official Records
Instrument No. 2007020939, as
thereafter amended, of the Pub-
lic Records of Sarasota County,
Florida, including all other
Common Elements and Limited
Common Elements appurtenant
thereto.

to the highest and best bidder for cash

at HYPERLINK "http://www.sarasota.
realforeclose.com" www.sarasota.real-
foreclose.com, at 9:00 a.m. on the 3rd
day of December, 2012.

ANY PERSON CLAIMING AN IN-
TEREST IN THE SURPLUS FROM
THE SALE, IF ANY, OTHER THAN
THE PROPERTY OWNER AS OF
THE DATE OF THE LIS PENDENS
MUST FILE A CLAIM WITHIN SIXTY
(60) DAYS AFTER THE SALE.

In accordance with the Americans
With Disabilities Act, persons needing
a reasonable accommodation to par-
ticipate in this proceeding should con-
tact the Clerk of the Circuit Court no
later than seven business days prior to
the proceeding at the Sarasota County
Courthouse. Telephone 941-861-7425
(Sarasota and Venice) or 1-800-955-
8770 via Florida Relay Service.

Dated: October 5, 2012

HANKIN, PERSSON,
MCCLLENATHEN,
COHEN & DARNELL
/s/ Kelly M. Fernandez
Kelly M. Fernandez, Esq.
Florida Bar No. 0676081
1820 Ringling Boulevard
Sarasota, FL 34236
Telephone: (941) 365-4950
Facsimile: (941) 365-3259
kfernandez@sarasotalawfirm.com
COUNSEL FOR PLAINTIFF
October 12, 19, 2012 12-3881S

FIRST INSERTION

NOTICE OF ACTION -
CONSTRUCTIVE SERVICE
IN THE CIRCUIT COURT OF THE
TWELFTH JUDICIAL CIRCUIT IN
AND FOR SARASOTA COUNTY,
FLORIDA
GENERAL JURISDICTION
DIVISION

CASE NO: 2011 CA 008437 NC
CITIMORTGAGE, INC.

Plaintiff, vs.
HOLLY T. SCHRAMM, SOLE
SURVIVING TRUSTEE OF
THE JOSEPH G. SCHRAMM
REVOCABLE TRUST
AGREEMENT DATED OCTOBER
1, 2002; UNKNOWN TENANT
1; UNKNOWN TENANT #2;
UNKNOWN BENEFICIARIES
OF THE JOSEPH G. SCHRAMM
REVOCABLE TRUST
AGREEMENT DATED OCTOBER
1, 2002, ET AL
Defendant(s)

TO: THE UNKNOWN BENEFI-
CIARIES OF THE JOSEPH G. SCH-
RAMM REVOCABLE TR AGREEM-
ENT DATED OCTOBER 1, 2002
whose residence is unknown if he/
she/they be living; and if he/she/they
be dead, the unknown defendants
who may be spouses, heirs, devisees,
grantees, assignees, lienors, creditors,
trustees, and all parties claiming an in-
terest by, through, under or against the
Defendants, who are not known to be
dead or alive, and all parties having or
claiming to have any right, title or in-
terest in the property described in the
mortgage being foreclosed herein.

YOU ARE HEREBY NOTIFIED
that an action to foreclose a mortgage
on the following property:
LOT 21, BLOCK C, NEW-
TOWN HEIGHTS, AS PER

PLAT THEREOF RECORDED
PLAT BOOK 1, PAGE 108, OF
THE PUBLIC RECORDS OF
SARASOTA COUNTY, FLO-
RYDA.

has been filed against you and you are
required to serve a copy of your writ-
ten defenses, if any, to it on counsel for
Plaintiff, whose address is 3010 North
Military Trail, Suite 300, Boca Raton,
Florida 33431 on or before 11/13/12/
(30 days from Date of First Publica-
tion of this Notice) and file the original
with the clerk of this court either before
service on Plaintiff's attorney or im-
mediately thereafter; otherwise a default
will be entered against you for the relief
demanded in the complaint or petition
filed herein.

THIS NOTICE SHALL BE PUB-
LISHED ONCE A WEEK FOR TWO
(2) CONSECUTIVE WEEKS.

In accordance with the Americans
With Disabilities Act, persons needing
a reasonable accommodation to par-
ticipate in this proceeding should con-
tact the Clerk of the Circuit Court no
later than seven business days prior to
the proceeding at the Sarasota County
Courthouse. Telephone 941-861-7425
(Sarasota and Venice) or 1-800-955-
8770 via Florida Relay Service.

WITNESS my hand and the seal of
this Court at County, Florida, this 3 day
of October, 2012.

CLERK OF THE CIRCUIT COURT
(SEAL) BY: G. Kopinsky
DEPUTY CLERK

ROBERTSON, ANSCHUTZ, AND
SCHNEID, PL
ATTORNEY FOR PLAINTIFF
3010 NORTH MILITARY TRAIL,
SUITE 300
BOCA RATON, FL 33431
October 12, 19, 2012 12-3893S

FIRST INSERTION

NOTICE OF ACTION
IN THE CIRCUIT COURT OF THE
TWELFTH JUDICIAL CIRCUIT
IN AND FOR SARASOTA COUNTY,
FLORIDA
CIVIL ACTION

CASE NO.: 58-2012-CA-000454 NC
DIVISION: C
SUNTRUST BANK,
Plaintiff, vs.

JULIAN STEED, et al,
Defendant(s).
TO:
JULIAN STEED
LAST KNOWN ADDRESS:
The Paddock Orchard Crescent Bristol
BS11 9RW England

CURRENT ADDRESS:
The Paddock Orchard Crescent Bristol
BS11 9RW England

ERICA BEALEY
LAST KNOWN ADDRESS:
The Paddock Orchard Crescent Bristol
BS11 9RW England

CURRENT ADDRESS:
The Paddock Orchard Crescent Bristol
BS11 9RW England

ANY AND ALL UNKNOWN PAR-
TIES CLAIMING BY, THROUGH,
UNDER, AND AGAINST THE
HEREIN NAMED INDIVIDUAL
DEFENDANT(S) WHO ARE NOT
KNOWN TO BE DEAD OR ALIVE,
WHETHER SAID UNKNOWN PAR-
TIES MAY CLAIM AN INTEREST
AS SPOUSES, HEIRS, DEVISEES,
GRANTEES, OR OTHER CLAIM-
ANTS
LAST KNOWN ADDRESS: UN-
KNOWN
CURRENT ADDRESS: UNKNOWN
YOU ARE NOTIFIED that an action
to foreclose a mortgage on the follow-
ing property in SARASOTA COUNTY,

Florida:

LOT 1, BLOCK G, FOREST
LAKES COUNTRY CLUB ES-
TATES, UNIT NO. 1, ACCORD-
ING TO THE PLAT THEREOF
RECORDED IN PLAT BOOK
17, PAGE 31, OF THE PUBLIC
RECORDS OF SARASOTA
COUNTY, FLORIDA

has been filed against you and you are
required to serve a copy of your written
defenses within 30 days after the first pub-
lication, if any, on Ronald R Wolfe & As-
sociates, P.L., Plaintiff's attorney, whose
address is 4919 Memorial Highway, Suite
200, Tampa, Florida 33634, and file the
original with this Court either before ser-
vice on Plaintiff's attorney or immediately
thereafter; otherwise a default will be en-
tered against you for the relief demanded
in the Complaint or petition.

This notice shall be published once
each week for two consecutive weeks in
the Gulf Coast Business Review.

In accordance with the Americans
With Disabilities Act, persons needing
a reasonable accommodation to par-
ticipate in this proceeding should con-
tact the Clerk of the Circuit Court no
later than seven business days prior to
the proceeding at the Sarasota County
Courthouse. Telephone 941-861-7425
(Sarasota and Venice) or 1-800-955-
8770 via Florida Relay Service.

WITNESS my hand and the seal of
this Court on this 2nd day of October,
2012.

Karen E. Rushing
Clerk of the Court
(SEAL) By: Eva Olivia
As Deputy Clerk

RONALD R WOLFE
& ASSOCIATES, P.L.,
Plaintiff's attorney,
4919 Memorial Highway, Suite 200,
Tampa, Florida 33634
F11014748
October 12, 19, 2012 12-3901S

FIRST INSERTION

NOTICE OF ACTION-
FORECLOSURE PROCEEDINGS
IN THE CIRCUIT COURT OF THE
12TH JUDICIAL CIRCUIT
IN AND FOR SARASOTA COUNTY,
FLORIDA

CASE NO. 58-2012-CA-005318 NC
PNC BANK, NATIONAL
ASSOCIATION, SUCCESSOR BY
MERGER TO NATIONAL CITY
MORTGAGE, A DIVISION OF
NATIONAL CITY BANK
Plaintiff, vs.
JOHN L. ILKO, JR., AKA DR.
JOHN L. ILKO; et al.
Defendant(s)

TO: SALLY J. ILKO,
including any unknown spouse of the
Defendant, if remarried and if said
Defendant is dead, his/her respec-
tive unknown spouse, heirs, devisees,
grantees, assignees, creditors, lien
holders, and trustees, and all other
persons claiming by, through, under or
against the named Defendant; and the
aforementioned named Defendant and
such of the aforementioned unknown
Defendant and such of the unknown
named Defendant as may be infants, in-
competents, or otherwise not sui juris.

YOU ARE HEREBY NOTIFIED
that an action to foreclose a mortgage
on the following described property,
to-wit:

Lot 19, Block 752, 12th addition
to Port Charlotte Subdivision,
according to the plat thereof,
recorded in Plat Book 13, Pag-
es 8, 8A thru 8V, of the Public
Records of Sarasota County,
Florida.

More commonly known as Lot

19 Kennett Street, North Port,
FL 34288

This action has been filed against you,
and you are required to serve a copy
of your written defense, if any, to it on
Plaintiff's attorney, Weltman, Wein-
berg & Reis Co., LPA, whose address
is 550 West Cypress Creek Road, Suite
550, Fort Lauderdale, FL 33309, on or
before 30 days after date of first pub-
lication, which is November 12 2012,
and file the original with the Clerk of
the Circuit Court either before service
on Plaintiff's attorney or immediately
thereafter; otherwise a default will be
entered against you for the relief de-
manded in the Complaint.

In accordance with the Americans
With Disabilities Act, persons needing
a reasonable accommodation to par-
ticipate in this proceeding should con-
tact the Clerk of the Circuit Court no
later than seven business days prior to
the proceeding at the Sarasota County
Courthouse. Telephone 941-861-7425
(Sarasota and Venice) or 1-800-955-
8770 via Florida Relay Service.

Witness my hand and seal of this
Court on the 3rd day of October, 2012.

Karen E. Rushing, Clerk
Sarasota County, Florida
(SEAL) By: Eva Olivia
Deputy Clerk

WELTMAN, WEINBERG &
REIS CO., L.P.A.
Attorney for Plaintiff
550 West Cypress Creek Road
Suite 550
Fort Lauderdale, FL 33309
Telephone No.: 954 740-5200
Facsimile: 954 740-5290
WWR File #10098927
October 12, 19, 2012 12-3902S

FIRST INSERTION

NOTICE OF ACTION
IN THE CIRCUIT COURT OF THE
TWELFTH JUDICIAL CIRCUIT OF
THE STATE OF FLORIDA, IN AND
FOR SARASOTA COUNTY
CIVIL DIVISION

CASE NO. 2012-CA-006518-NC
GREEN TREE SERVICING LLC,
Plaintiff, vs.

DALE E. DESJARDINS, JR.;
UNKNOWN SPOUSE OF
DALE E. DESJARDINS, JR.;
HELGA M. HRLIC; UNKNOWN
SPOUSE OF HELGA M. HRLIC;
IBERIABANK, ASSIGNEE
OF THE FEDERAL DEPOSIT
INSURANCE CORPORATION AS
RECEIVER FOR CENTURY BANK,
F.S.B.; TRANSCAPITAL BANK;
IBERIABANK; SYNOVUS BANK
F/K/A FIRST FLORIDA BANK;
IBERIABANK, SUCCESSOR IN
INTEREST TO ORION BANK;
ABSOLUTE METAL ROOFING,
INC.; GULF GATE COMMUNITY
ASSOCIATION, INC.;
UNKNOWN TENANT #1;
UNKNOWN TENANT #2;
Defendant(s)

TO: HELGA M. HRLIC;
Whose residence(s) is/are unknown.

YOU ARE HEREBY required to
file your answer or written defenses, if
any, in the above proceeding with the
Clerk of this Court, and to serve a copy
thereof upon the plaintiff's attorney,
Law Offices of Daniel C. Consuegra,
9204 King Palm Drive, Tampa, FL
33619-1328, telephone (813) 915-8660,
facsimile (813) 915-0559, within thirty
days of the first publication of this No-
tice, the nature of this proceeding being
a suit for foreclosure of mortgage

against the following described prop-
erty, to wit:

Lot 21, Block 45, GULF GATE,
UNIT NO. 11, according to the
plat thereof, as recorded in Plat
Book 18, Pages 20 and 20A, of
the Public Records of Sarasota
County, Florida.

If you fail to file your response or an-
swer, if any, in the above proceeding
with the Clerk of this Court, and to
serve a copy thereof upon the plain-
tiff's attorney, Law Offices of Daniel
C. Consuegra, 9204 King Palm Drive,
Tampa, Florida 33619-1328, telephone
(813) 915-8660, facsimile (813) 915-
0559, within thirty days of the first
publication of this Notice, a default will
be entered against you for the relief de-
manded in the Complaint or Petition.

In accordance with the Americans
With Disabilities Act, persons needing
a reasonable accommodation to par-
ticipate in this proceeding should con-
tact the Clerk of the Circuit Court no
later than seven business days prior to
the proceeding at the Sarasota County
Courthouse. Telephone 941-861-7425
(Sarasota and Venice) or 1-800-955-
8770 via Florida Relay Service.

DATED at SARASOTA County this
4 day of October, 2012.

KAREN E. RUSHING, CLERK
Clerk of the Circuit Court
(SEAL) By M. Foulks
Deputy Clerk

LAW OFFICES OF
DANIEL C. CONSUEGRA
9204 King Palm Drive
Tampa, FL 33619-1328
Telephone (813) 915-8660
Facsimile (813) 915-0559
October 12, 19, 2012 12-3876S

FIRST INSERTION

NOTICE OF ACTION
IN THE CIRCUIT COURT OF THE
TWELFTH JUDICIAL CIRCUIT
IN AND FOR

SARASOTA COUNTY, FLORIDA
CASE NO. 2012 CA 005092 NC
FEDERAL NATIONAL
MORTGAGE ASSOCIATION,
Plaintiff, vs.

KEVIN M. BARRETT,
UNKNOWN SPOUSE OF KEVIN
M. BARRETT, UNKNOWN
TENANT(S) IN POSSESSION #1
and #2, et al.
Defendant(s).

TO: KEVIN M. BARRETT
(Last Known Address)
315 W SEMINOLE DR
VENICE, FL 34293
1002 AUBURN LAKES CIRCLE
VENICE, FL 34292
(Current Residence Unknown) if liv-
ing, and ALL OTHER UNKNOWN
PARTIES, including, if a named De-
fendant is deceased, the personal
representatives, the surviving spouse,
heirs, devisees, grantees, creditors, and
all other parties claiming, by, through,
under or against that Defendant, and
all claimants, persons or parties, natu-
ral or corporate, or whose exact legal
status is unknown, claiming under any
of the above named or described De-
fendants

YOU ARE NOTIFIED that an action
for Foreclosure of Mortgage on the fol-
lowing described property:

LOTS 8834 AND 8835, SOUTH
VENICE, UNIT NO. 31, AS PER
PLAT THEREOF RECORDED
IN PLAT BOOK 6, PAGE 84,
THE PUBLIC RECORDS OF
SARASOTA COUNTY, FLOR-
IDA.

A/K/A: 315 W SEMINOLE DR,
VENICE, FL 34293.

has been filed against you and you are
required to serve a copy of your written
defenses, if any, to it on Brian L. Ros-
aler, Esquire, POPKIN & ROSALER,
P.A., 1701 West Hillsboro Boulevard,
Suite 400, Deerfield Beach, FL 33442.,
Attorney for Plaintiff, whose on or be-
fore 11/13/2012, a date which is within
thirty (30) days after the first publica-
tion of this Notice in the Gulf Coast
Business Review and file the original
with the Clerk of this Court either be-
fore service on Plaintiff's attorney or
immediately thereafter; otherwise, a
default will be entered against you for
the relief demanded in the complaint.

In accordance with the Americans
With Disabilities Act, persons needing
a reasonable accommodation to par-
ticipate in this proceeding should con-
tact the Clerk of the Circuit Court no
later than seven business days prior to
the proceeding at the Sarasota County
Courthouse. Telephone 941-861-7425
(Sarasota and Venice) or 1-800-955-
8770 via Florida Relay Service.

WITNESS my hand and the seal of
this Court on this 1 day of October,
201

FIRST INSERTION

NOTICE OF APPLICATION FOR TAX DEED

Notice is hereby given that US BANK CUSTODIAN FOR TRC-SPE, the holder of the certificate listed below, has filed said certificate for a tax deed to be issued. The certificate number and year of issuance, the description of the property, and the names in which the property is assessed are as follows:

Certificate Number: 837.000
Year of Issuance: 2010
Tax Deed File #: 12-0251 TD

Description of Property: 0054-02-0047 LOT 2 OAK SHORE HEIGHTS Name in which the property is assessed: LISA J WRIGHT & JON S WRIGHT All of said property being in the County of Sarasota, State of Florida. Unless the certificate is redeemed according to law, the property described in the certificate will be sold to the highest bidder at the Sarasota County Court House, 2000 Main Street, Historic Courtroom, East Wing, Sarasota, Florida, at 9:00 a.m. on the 16TH day of NOVEMBER, 2012.

Karen E. Rushing
Clerk Of The Circuit Court
Sarasota County, Florida
By: T. Lake, Deputy Clerk
October 12, 19, 26; November 2, 2012
12-3924S

FIRST INSERTION

NOTICE OF APPLICATION FOR TAX DEED

Notice is hereby given that MEKA SREENIVAS, the holder of the certificate listed below, has filed said certificate for a tax deed to be issued. The certificate number and year of issuance, the description of the property, and the names in which the property is assessed are as follows:

Certificate Number: 20106.000
Year of Issuance: 2010
Tax Deed File #: 12-0252 TD

Description of Property: 0779-02-3730 LOT 373, GRAN PARADISO, PHASE 1 Name in which the property is assessed: GRAN PARADISO I LLC All of said property being in the County of Sarasota, State of Florida. Unless the certificate is redeemed according to law, the property described in the certificate will be sold to the highest bidder at the Sarasota County Court House, 2000 Main Street, Historic Courtroom, East Wing, Sarasota, Florida, at 9:00 a.m. on the 16TH day of NOVEMBER, 2012.

Karen E. Rushing
Clerk Of The Circuit Court
Sarasota County, Florida
By: T. Lake, Deputy Clerk
October 12, 19, 26; November 2, 2012
12-3925S

FIRST INSERTION

NOTICE OF APPLICATION FOR TAX DEED

Notice is hereby given that USAMER-IBANK MAGNOLIA TC 2 LLC, the holder of the certificate listed below, has filed said certificate for a tax deed to be issued. The certificate number and year of issuance, the description of the property, and the names in which the property is assessed are as follows:

Certificate Number: 213.000
Year of Issuance: 2010
Tax Deed File #: 12-0256 TD

Description of Property: 0025-08-0060 LOT 842 TRI-PAR ESTATES UNIT 9, ORI 2007182876 Name in which the property is assessed: PATRICIA BISHOP All of said property being in the County of Sarasota, State of Florida. Unless the certificate is redeemed according to law, the property described in the certificate will be sold to the highest bidder at the Sarasota County Court House, 2000 Main Street, Historic Courtroom, East Wing, Sarasota, Florida, at 9:00 a.m. on the 16TH day of NOVEMBER, 2012.

Karen E. Rushing
Clerk Of The Circuit Court
Sarasota County, Florida
By: T. Lake, Deputy Clerk
October 12, 19, 26; November 2, 2012
12-3927S

FIRST INSERTION

NOTICE OF APPLICATION FOR TAX DEED

Notice is hereby given that USAMER-IBANK MAGNOLIA TC 2 LLC, the holder of the certificate listed below, has filed said certificate for a tax deed to be issued. The certificate number and year of issuance, the description of the property, and the names in which the property is assessed are as follows:

Certificate Number: 2828.000
Year of Issuance: 2010
Tax Deed File #: 12-0262 TD

Description of Property: 0170-01-0034 LOT 13 BLK B MOUNT PLEASANT Name in which the property is assessed: SANDRA ANDERSON & JAMES ANDERSON All of said property being in the County of Sarasota, State of Florida. Unless the certificate is redeemed according to law, the property described in the certificate will be sold to the highest bidder at the Sarasota County Court House, 2000 Main Street, Historic Courtroom, East Wing, Sarasota, Florida, at 9:00 a.m. on the 16TH day of NOVEMBER, 2012.

Karen E. Rushing
Clerk Of The Circuit Court
Sarasota County, Florida
By: T. Lake, Deputy Clerk
October 12, 19, 26; November 2, 2012
12-3932S

FIRST INSERTION

NOTICE OF APPLICATION FOR TAX DEED

Notice is hereby given that USAMER-IBANK MAGNOLIA TC 2 LLC, the holder of the certificate listed below, has filed said certificate for a tax deed to be issued. The certificate number and year of issuance, the description of the property, and the names in which the property is assessed are as follows:

Certificate Number: 8229.000
Year of Issuance: 2010
Tax Deed File #: 12-0266 TD

Description of Property: 0974-18-2001 LOT 1 BLK 1820 37TH ADD TO PORT CHARLOTTE Name in which the property is assessed: KISHA L SIMS All of said property being in the County of Sarasota, State of Florida. Unless the certificate is redeemed according to law, the property described in the certificate will be sold to the highest bidder at the Sarasota County Court House, 2000 Main Street, Historic Courtroom, East Wing, Sarasota, Florida, at 9:00 a.m. on the 16TH day of NOVEMBER, 2012.

Karen E. Rushing
Clerk Of The Circuit Court
Sarasota County, Florida
By: T. Lake, Deputy Clerk
October 12, 19, 26; November 2, 2012
12-3936S

FIRST INSERTION

NOTICE OF APPLICATION FOR TAX DEED

Notice is hereby given that USAMER-IBANK MAGNOLIA TC 2 LLC, the holder of the certificate listed below, has filed said certificate for a tax deed to be issued. The certificate number and year of issuance, the description of the property, and the names in which the property is assessed are as follows:

Certificate Number: 2866.000
Year of Issuance: 2010
Tax Deed File #: 12-0264 TD

Description of Property: 0170-15-0005 LOT 12 BLK C NOKOMIS HEIGHTS Name in which the property is assessed: TERRA DEL SOLE LLC All of said property being in the County of Sarasota, State of Florida. Unless the certificate is redeemed according to law, the property described in the certificate will be sold to the highest bidder at the Sarasota County Court House, 2000 Main Street, Historic Courtroom, East Wing, Sarasota, Florida, at 9:00 a.m. on the 16TH day of NOVEMBER, 2012.

Karen E. Rushing
Clerk Of The Circuit Court
Sarasota County, Florida
By: T. Lake, Deputy Clerk
October 12, 19, 26; November 2, 2012
12-3934S

FIRST INSERTION

NOTICE OF APPLICATION FOR TAX DEED

Notice is hereby given that CHRIS STEELMAN, the holder of the certificate listed below, has filed said certificate for a tax deed to be issued. The certificate number and year of issuance, the description of the property, and the names in which the property is assessed are as follows:

Certificate Number: 10827.000
Year of Issuance: 2010
Tax Deed File #: 12-0246 TD

Description of Property: 1131-23-3580 TRACT CL CONTAINING 5.6 AC M/L 47TH ADD TO PORT CHARLOTTE Name in which the property is assessed: CHARLOTTE SARASOTA HOLDINGS LL All of said property being in the County of Sarasota, State of Florida. Unless the certificate is redeemed according to law, the property described in the certificate will be sold to the highest bidder at the Sarasota County Court House, 2000 Main Street, Historic Courtroom, East Wing, Sarasota, Florida, at 9:00 a.m. on the 16TH day of NOVEMBER, 2012.

Karen E. Rushing
Clerk Of The Circuit Court
Sarasota County, Florida
By: T. Lake, Deputy Clerk
October 12, 19, 26; November 2, 2012
12-3920S

FIRST INSERTION

NOTICE OF APPLICATION FOR TAX DEED

Notice is hereby given that YONG ZHAO, the holder of the certificate listed below, has filed said certificate for a tax deed to be issued. The certificate number and year of issuance, the description of the property, and the names in which the property is assessed are as follows:

Certificate Number: 10208.000
Year of Issuance: 2010
Tax Deed File #: 12-0247 TD

Description of Property: 1123-24-6625 LOT 25 BLK 2466 49TH ADD TO PORT CHARLOTTE Name in which the property is assessed: DAVID SIMMONS All of said property being in the County of Sarasota, State of Florida. Unless the certificate is redeemed according to law, the property described in the certificate will be sold to the highest bidder at the Sarasota County Court House, 2000 Main Street, Historic Courtroom, East Wing, Sarasota, Florida, at 9:00 a.m. on the 16TH day of NOVEMBER, 2012.

Karen E. Rushing
Clerk Of The Circuit Court
Sarasota County, Florida
By: T. Lake, Deputy Clerk
October 12, 19, 26; November 2, 2012
12-3921S

FIRST INSERTION

NOTICE OF APPLICATION FOR TAX DEED

Notice is hereby given that YONG ZHAO, the holder of the certificate listed below, has filed said certificate for a tax deed to be issued. The certificate number and year of issuance, the description of the property, and the names in which the property is assessed are as follows:

Certificate Number: 10260.000
Year of Issuance: 2010
Tax Deed File #: 12-0248 TD

Description of Property: 1124-10-6801 LOT 1 BLK 1068 24TH ADD TO PORT CHARLOTTE Name in which the property is assessed: LUDMILA CHESNAKOVA All of said property being in the County of Sarasota, State of Florida. Unless the certificate is redeemed according to law, the property described in the certificate will be sold to the highest bidder at the Sarasota County Court House, 2000 Main Street, Historic Courtroom, East Wing, Sarasota, Florida, at 9:00 a.m. on the 16TH day of NOVEMBER, 2012.

Karen E. Rushing
Clerk Of The Circuit Court
Sarasota County, Florida
By: T. Lake, Deputy Clerk
October 12, 19, 26; November 2, 2012
12-3922S

FIRST INSERTION

NOTICE OF APPLICATION FOR TAX DEED

Notice is hereby given that US BANK CUSTODIAN FOR TRC-SPE, the holder of the certificate listed below, has filed said certificate for a tax deed to be issued. The certificate number and year of issuance, the description of the property, and the names in which the property is assessed are as follows:

Certificate Number: 749.000
Year of Issuance: 2010
Tax Deed File #: 12-0250 TD

Description of Property: 0048-07-0043 LOTS 10 & 12 BLK B HIGHLAND CREST Name in which the property is assessed: TERESA GOLDEN All of said property being in the County of Sarasota, State of Florida. Unless the certificate is redeemed according to law, the property described in the certificate will be sold to the highest bidder at the Sarasota County Court House, 2000 Main Street, Historic Courtroom, East Wing, Sarasota, Florida, at 9:00 a.m. on the 16TH day of NOVEMBER, 2012.

Karen E. Rushing
Clerk Of The Circuit Court
Sarasota County, Florida
By: T. Lake, Deputy Clerk
October 12, 19, 26; November 2, 2012
12-3923S

FIRST INSERTION

NOTICE OF APPLICATION FOR TAX DEED

Notice is hereby given that TRI-STATE FUNDING LLLP SAVING, the holder of the certificate listed below, has filed said certificate for a tax deed to be issued. The certificate number and year of issuance, the description of the property, and the names in which the property is assessed are as follows:

Certificate Number: 6745.000
Year of Issuance: 2009
Tax Deed File #: 12-0187 TD

Description of Property: 0853-03-0039 LOT 19 BLK 4 PROSPECT PARK SUB OF BLK 5 Name in which the property is assessed: KELLY STEVENS & JOSEPH P STEVENS All of said property being in the County of Sarasota, State of Florida. Unless the certificate is redeemed according to law, the property described in the certificate will be sold to the highest bidder at the Sarasota County Court House, 2000 Main Street, Historic Courtroom, East Wing, Sarasota, Florida, at 9:00 a.m. on the 16TH day of NOVEMBER, 2012.

Karen E. Rushing
Clerk Of The Circuit Court
Sarasota County, Florida
By: T. Lake, Deputy Clerk
October 12, 19, 26; November 2, 2012
12-3917S

FIRST INSERTION

NOTICE OF APPLICATION FOR TAX DEED

Notice is hereby given that USAMER-IBANK MAGNOLIA TC 2 LLC, the holder of the certificate listed below, has filed said certificate for a tax deed to be issued. The certificate number and year of issuance, the description of the property, and the names in which the property is assessed are as follows:

Certificate Number: 2836.000
Year of Issuance: 2010
Tax Deed File #: 12-0263 TD

Description of Property: 0170-02-0021 LOT 4 BLK D MOUNT PLEASANT Name in which the property is assessed: MELISSA CLARK & WILLIAM C TILLINGHAST & AMANDA TILLINGHAST All of said property being in the County of Sarasota, State of Florida. Unless the certificate is redeemed according to law, the property described in the certificate will be sold to the highest bidder at the Sarasota County Court House, 2000 Main Street, Historic Courtroom, East Wing, Sarasota, Florida, at 9:00 a.m. on the 16TH day of NOVEMBER, 2012.

Karen E. Rushing
Clerk Of The Circuit Court
Sarasota County, Florida
By: T. Lake, Deputy Clerk
October 12, 19, 26; November 2, 2012
12-3933S

FIRST INSERTION

NOTICE OF APPLICATION FOR TAX DEED

Notice is hereby given that PAMELA SHETLER, the holder of the certificate listed below, has filed said certificate for a tax deed to be issued. The certificate number and year of issuance, the description of the property, and the names in which the property is assessed are as follows:

Certificate Number: 4678.000
Year of Issuance: 2009
Tax Deed File #: 12-0253 TD

Description of Property: 0407-03-0035 LOT 62 COM AT QUARTER SEC COR ON N LINE OF SEC 7 RUN S 260 FT W 166.4 FT FOR POB CONT W 69.1 FT N 100 FT E 45 FT S 100 FT TO POB ORI 2005202321 Name in which the property is assessed: DARCIE SMITH & DOUGLAS J WINTERSTEEN All of said property being in the County of Sarasota, State of Florida. Unless the certificate is redeemed according to law, the property described in the certificate will be sold to the highest bidder at the Sarasota County Court House, 2000 Main Street, Historic Courtroom, East Wing, Sarasota, Florida, at 9:00 a.m. on the 16TH day of NOVEMBER, 2012.

Karen E. Rushing
Clerk Of The Circuit Court
Sarasota County, Florida
By: T. Lake, Deputy Clerk
October 12, 19, 26; November 2, 2012
12-3926S

FIRST INSERTION

NOTICE OF APPLICATION FOR TAX DEED

Notice is hereby given that USAMER-IBANK MAGNOLIA TC 2 LLC, the holder of the certificate listed below, has filed said certificate for a tax deed to be issued. The certificate number and year of issuance, the description of the property, and the names in which the property is assessed are as follows:

Certificate Number: 224.000
Year of Issuance: 2010
Tax Deed File #: 12-0258 TD

Description of Property: 0025-11-0120 LOT 155 SUBJ TO RIGHT OF FLIGHT ESMT TO SARASOTA MANATEE AIRPORT AUTHORITY PER ORI 2001071027 TRI-PAR ESTATES UNIT 4 Name in which the property is assessed: JANET A JACOBSEN & JAMES A JACOBSEN All of said property being in the County of Sarasota, State of Florida. Unless the certificate is redeemed according to law, the property described in the certificate will be sold to the highest bidder at the Sarasota County Court House, 2000 Main Street, Historic Courtroom, East Wing, Sarasota, Florida, at 9:00 a.m. on the 16TH day of NOVEMBER, 2012.

Karen E. Rushing
Clerk Of The Circuit Court
Sarasota County, Florida
By: T. Lake, Deputy Clerk
October 12, 19, 26; November 2, 2012
12-3929S

FIRST INSERTION

NOTICE OF APPLICATION FOR TAX DEED

Notice is hereby given that USAMER-IBANK MAGNOLIA TC 2 LLC, the holder of the certificate listed below, has filed said certificate for a tax deed to be issued. The certificate number and year of issuance, the description of the property, and the names in which the property is assessed are as follows:

Certificate Number: 820.000
Year of Issuance: 2010
Tax Deed File #: 12-0260 TD

Description of Property: 0052-12-0031 COM AT SW COR OF NW 1/4 OF SEC 27 TH N-0-55-E 613 FT TH E 824 FT TH N-0-55-E 560 FT FOR POB TH CONT N-0 -55-E 70 FT TH E 140.73 FT TH S-0-55-W 70 FT TH W 140.73 FT TO POB Name in which the property is assessed: GEORGE J MORRIS JR EST All of said property being in the County of Sarasota, State of Florida. Unless the certificate is redeemed according to law, the property described in the certificate will be sold to the highest bidder at the Sarasota County Court House, 2000 Main Street, Historic Courtroom, East Wing, Sarasota, Florida, at 9:00 a.m. on the 16TH day of NOVEMBER, 2012.

Karen E. Rushing
Clerk Of The Circuit Court
Sarasota County, Florida
By: T. Lake, Deputy Clerk
October 12, 19, 26; November 2, 2012
12-3931S

FIRST INSERTION

NOTICE OF APPLICATION FOR TAX DEED

Notice is hereby given that USAMER-IBANK MAGNOLIA TC 2 LLC, the holder of the certificate listed below, has filed said certificate for a tax deed to be issued. The certificate number and year of issuance, the description of the property, and the names in which the property is assessed are as follows:

Certificate Number: 9123.000
Year of Issuance: 2010
Tax Deed File #: 12-0268 TD

Description of Property: 0996-19-1715 LOT 14, LESS THE N 23 FT THEREOF & THE N 38 FT OF LOT 15, BLK 1917, 41ST ADD TO PORT CHARLOTTE 1ST REPLAT, ORI 2005183842 Name in which the property is assessed: BARBARA J MEYER & JAMES I MEYER All of said property being in the County of Sarasota, State of Florida. Unless the certificate is redeemed according to law, the property described in the certificate will be sold to the highest bidder at the Sarasota County Court House, 2000 Main Street, Historic Courtroom, East Wing, Sarasota, Florida, at 9:00 a.m. on the 16TH day of NOVEMBER, 2012.

Karen E. Rushing
Clerk Of The Circuit Court
Sarasota County, Florida
By: T. Lake, Deputy Clerk
October 12, 19, 26; November 2, 2012
12-3938S

FIRST INSERTION

NOTICE OF APPLICATION FOR TAX DEED

Notice is hereby given that USAMER-IBANK MAGNOLIA TC 2 LLC, the holder of the certificate listed below, has filed said certificate for a tax deed to be issued. The certificate number and year of issuance, the description of the property, and the names in which the property is assessed are as follows:

Certificate Number: 416.000
Year of Issuance: 2010
Tax Deed File #: 12-0259 TD

Description of Property: 0030-06-0018 COM SE COR OF W 1/2 OF NE 1/4 OF SW 1/4 SEC 9 TH N 659.6 FT TH S-80-22-W 250.4 FT FOR POB TH CONT S-80-22-W 200 FT TH S-8 -34-E 114.84 FT TH N-81-39-20-E 99.98 FT TH N-8-34-W 100.08 FT TH N-80-22-E 100 FT TH N-8-34-W 17 FT TO POB OR 2117/0878 OR 2117/0882 OR 2124/1761 Name in which the property is assessed: MIREILLE ARNOSI All of said property being in the County of Sarasota, State of Florida. Unless the certificate is redeemed according to law, the property described in the certificate will be sold to the highest bidder at the Sarasota County Court House, 2000 Main Street, Historic Courtroom, East Wing, Sarasota, Florida, at 9:00 a.m. on the 16TH day of NOVEMBER, 2012.

Karen E. Rushing
Clerk Of The Circuit Court
Sarasota County, Florida
By: T. Lake, Deputy Clerk
October 12, 19, 26; November 2, 2012
12-3930S

FIRST INSERTION

NOTICE OF APPLICATION FOR TAX DEED

Notice is hereby given that CHRIS STEELMAN, the holder of the certificate listed below, has filed said certificate for a tax deed to be issued. The certificate number and year of issuance, the description of the property, and the names in which the property is assessed are as follows:

Certificate Number: 9248.000
Year of Issuance: 2010
Tax Deed File #: 12-0245 TD

Description of Property: 0997-00-5060 COM AT INTRIS OF ELY R/W OF S PAN AMERICAN BLVD AND NLY LINE OF TAMIAMI TRAIL, TH N 13-27-52 E 651.39 FT FOR POB, TH N 13-27-52 E 83.03 FT, TH NELY ALG CURVE TO LEFT 67.25 FT, TH S 86-31-07 E 30 FT, TH S 50-48-24 E 59.39 FT, TH S 86-31-07 E 355.77 FT, TH SWLY ALG CURVE TO RIGHT 80.4 FT, TH N 86-31-07 W 360 FT, TH S 62-34-32 W 66.14 FT, TH N 86-31-07 W 30.46 FT TO POB, BEING SAME PARCEL DESC AS NON EXCLUSIVE EASEMENT FOR INGRESS/EGRESS & UTILITIES IN ORI 1998150931 Name in which the property is assessed: TARPON IV LLC All of said property being in the County of Sarasota, State of Florida. Unless the certificate is redeemed according to law, the property described in the certificate will be sold to the highest bidder at the Sarasota County Court House, 2000 Main Street, Historic Courtroom, East Wing, Sarasota, Florida, at 9:00 a.m. on the 16TH day of NOVEMBER, 2012.

Karen E. Rushing
Clerk Of The Circuit Court
Sarasota County, Florida
By: T. Lake, Deputy Clerk
October 12, 19, 26; November 2, 2012
12-3919S

HOW TO PUBLISH YOUR LEGAL NOTICE IN THE GULF COAST BUSINESS REVIEW

FOR MORE INFORMATION, CALL:
(813) 221-9505 Hillsborough, Pasco
(727) 447-7784 Pinellas
(941) 906-9386 Manatee, Sarasota, Lee
(239) 263-0122 Collier
(407) 271-4855 Orange
Or e-mail: legal@review.net

GULF COAST Business Review
www.review.net

SUBSEQUENT INSERTIONS

FIRST INSERTION
NOTICE OF APPLICATION FOR TAX DEED
Notice is hereby given that USAMER-IBANK MAGNOLIA TC 2 LLC, the holder of the certificate listed below, has filed said certificate for a tax deed to be issued. The certificate number and year of issuance, the description of the property, and the names in which the property is assessed are as follows:

Certificate Number: 13144.000
Year of Issuance: 2010
Tax Deed File #: 12-0272 TD

Description of Property: 2024-06-0028 LOT 18 BLK C REPLAT OF IRVINGTON HEIGHTS
Name in which the property is assessed: ROSE S AMOS
All of said property being in the County of Sarasota, State of Florida. Unless the certificate is redeemed according to law, the property described in the certificate will be sold to the highest bidder at the Sarasota County Court House, 2000 Main Street, Historic Courtroom, East Wing, Sarasota, Florida, at 9:00 a.m. on the 16TH day of NOVEMBER, 2012.

Karen E. Rushing
Clerk Of The Circuit Court
Sarasota County, Florida
By: T. Lake, Deputy Clerk
October 12, 19, 26; November 2, 2012
12-3942S

FIRST INSERTION
NOTICE OF APPLICATION FOR TAX DEED
Notice is hereby given that USAMER-IBANK MAGNOLIA TC 2 LLC, the holder of the certificate listed below, has filed said certificate for a tax deed to be issued. The certificate number and year of issuance, the description of the property, and the names in which the property is assessed are as follows:

Certificate Number: 9458.000
Year of Issuance: 2010
Tax Deed File #: 12-0270 TD

Description of Property: 1004-01-8212 LOT 12 BLK 182 2ND ADD TO PORT CHARLOTTE
Name in which the property is assessed: MARY ANN ROPP
All of said property being in the County of Sarasota, State of Florida. Unless the certificate is redeemed according to law, the property described in the certificate will be sold to the highest bidder at the Sarasota County Court House, 2000 Main Street, Historic Courtroom, East Wing, Sarasota, Florida, at 9:00 a.m. on the 16TH day of NOVEMBER, 2012.

Karen E. Rushing
Clerk Of The Circuit Court
Sarasota County, Florida
By: T. Lake, Deputy Clerk
October 12, 19, 26; November 2, 2012
12-3940S

FIRST INSERTION
NOTICE OF APPLICATION FOR TAX DEED
Notice is hereby given that USAMER-IBANK MAGNOLIA TC 2 LLC, the holder of the certificate listed below, has filed said certificate for a tax deed to be issued. The certificate number and year of issuance, the description of the property, and the names in which the property is assessed are as follows:

Certificate Number: 9239.000
Year of Issuance: 2010
Tax Deed File #: 12-0269 TD

Description of Property: 0997-00-1109 LOT 9 BLK 11 PORT CHARLOTTE SUB
Name in which the property is assessed: WALTER J MCCARTHY
All of said property being in the County of Sarasota, State of Florida. Unless the certificate is redeemed according to law, the property described in the certificate will be sold to the highest bidder at the Sarasota County Court House, 2000 Main Street, Historic Courtroom, East Wing, Sarasota, Florida, at 9:00 a.m. on the 16TH day of NOVEMBER, 2012.

Karen E. Rushing
Clerk Of The Circuit Court
Sarasota County, Florida
By: T. Lake, Deputy Clerk
October 12, 19, 26; November 2, 2012
12-3939S

FOURTH INSERTION
NOTICE OF APPLICATION FOR TAX DEED
Notice is hereby given that PPTS HB CORP, the holder of the certificate listed below, has filed said certificate for a tax deed to be issued. The certificate number and year of issuance, the description of the property, and the names in which the property is assessed are as follows:

Certificate Number: 8384.000
Year of Issuance: 2008
Tax Deed File #: 10-0108 TD

Description of Property: 0997-00-2017 LOT 17 BLK 20 13TH ADD TO PORT CHARLOTTE
Name in which the property is assessed: JULIAN VAL & KATHLEEN PICKETT EST & ALEXANDER K MITCHELL
All of said property being in the County of Sarasota, State of Florida. Unless the certificate is redeemed according to law, the property described in the certificate will be sold to the highest bidder at the Sarasota County Court House, 2000 Main Street, Historic Courtroom, East Wing, Sarasota, Florida, at 9:00 a.m. on the 23RD day of OCTOBER, 2012.

Karen E. Rushing
Clerk Of The Circuit Court
Sarasota County, Florida
By: T. Lake, Deputy Clerk
September 21, 28; October 5, 12, 2012
12-3548S

SECOND INSERTION
NOTICE OF SALE
Public Storage, Inc.
PS Orangeto
Personal property consisting of sofas, TV's, clothes, boxes, household goods and other personal property used in home, office or garage will be sold or otherwise disposed of at public sales on the dates & times indicated below to satisfy Owners Lien for rent & fees due in accordance with Florida Statutes: Self-Storage Act, Sections 83.806 & 83.807. All items or spaces may not be available for sale. Cash or Credit cards only for all purchases & tax resale certificates required, if applicable.
Public Storage 21005
6133 S. Tamiami Trail
Sarasota, FL. 34231
Tuesday October 23, 2012
@ 1:30pm
1059 James Childress
2111 Kimberly Thrasher
3068 Harry Enright
3085 Sheila Abel
3138 Doris Hamilton

Public Storage 25445
1120 US Hwy 41 Bypass S
Venice, FL 34285
Tuesday October 23,
2012@2:30pm
C038 jon janney III
D028 angelica bell
H005 arthur shannon
October 5, 12, 2012
12-3802S

SECOND INSERTION
NOTICE OF PUBLIC SALE OF PERSONAL PROPERTY
METRO SELF STORAGE
Notice is hereby given that the undersigned self storage unit(s) will be sold at a public sale by competitive bidding, in their entirety to the highest bidder, on or after date and time below to satisfy the lien of Metro Self Storage for rental and other charges due from the undersigned. The said property has been stored and generally described below is located at the respective address. The sale will begin at the date and time below on or after on said date and will continue hour by hour until all units are sold.
Auctioneer Lic# AU4167 and AB2825,
10% Buyers Premium.
Tuesday October 23rd 2012
9:30 AM
619 Cattleman Road
Sarasota, FL. 34232
F11 Dawne Tracy
B23 Marc B Ayers,
Lynda Milks Johnson
The contents consist of general, household and miscellaneous items. The terms of the sale will be cash only and must be paid for at the time of the sale. All goods are sold as is. Metro Self Storage reserves the right to withdraw any or all units for the sale at any time. All contents must be removed within 48 hours or sooner.
October 5, 12, 2012
12-3842S

FIRST INSERTION
NOTICE OF APPLICATION FOR TAX DEED
Notice is hereby given that USAMER-IBANK MAGNOLIA TC 2 LLC, the holder of the certificate listed below, has filed said certificate for a tax deed to be issued. The certificate number and year of issuance, the description of the property, and the names in which the property is assessed are as follows:

Certificate Number: 12887.000
Year of Issuance: 2010
Tax Deed File #: 12-0271 TD

Description of Property: 2020-09-0039 LOT 23 BLK B NEWTOWN HEIGHTS
Name in which the property is assessed: GERALDINE L SINGLETON & ALFONZO SINGLETON
All of said property being in the County of Sarasota, State of Florida. Unless the certificate is redeemed according to law, the property described in the certificate will be sold to the highest bidder at the Sarasota County Court House, 2000 Main Street, Historic Courtroom, East Wing, Sarasota, Florida, at 9:00 a.m. on the 16TH day of NOVEMBER, 2012.

Karen E. Rushing
Clerk Of The Circuit Court
Sarasota County, Florida
By: T. Lake, Deputy Clerk
October 12, 19, 26; November 2, 2012
12-3941S

FIRST INSERTION
NOTICE OF APPLICATION FOR TAX DEED
Notice is hereby given that USAMER-IBANK MAGNOLIA TC 2 LLC, the holder of the certificate listed below, has filed said certificate for a tax deed to be issued. The certificate number and year of issuance, the description of the property, and the names in which the property is assessed are as follows:

Certificate Number: 9103.000
Year of Issuance: 2010
Tax Deed File #: 12-0267 TD

Description of Property: 0996-18-3201 LOT 1 LESS THE E 5 FT BLK 1832 38TH ADD TO PORT CHARLOTTE
Name in which the property is assessed: DANIEL BECERRA & ISABEL BECERRA & ZORAIDA RODRIGUEZ
All of said property being in the County of Sarasota, State of Florida. Unless the certificate is redeemed according to law, the property described in the certificate will be sold to the highest bidder at the Sarasota County Court House, 2000 Main Street, Historic Courtroom, East Wing, Sarasota, Florida, at 9:00 a.m. on the 16TH day of NOVEMBER, 2012.

Karen E. Rushing
Clerk Of The Circuit Court
Sarasota County, Florida
By: T. Lake, Deputy Clerk
October 12, 19, 26; November 2, 2012
12-3937S

FIRST INSERTION
NOTICE OF APPLICATION FOR TAX DEED
Notice is hereby given that USAMER-IBANK MAGNOLIA TC 2 LLC, the holder of the certificate listed below, has filed said certificate for a tax deed to be issued. The certificate number and year of issuance, the description of the property, and the names in which the property is assessed are as follows:

Certificate Number: 3930.000
Year of Issuance: 2010
Tax Deed File #: 12-0265 TD

Description of Property: 0408-16-0014 LOTS 34 35 BLK 204 EDGEWOOD SEC OF VENICE
Name in which the property is assessed: CANAL ROAD PROPERTY MGMT LLC
All of said property being in the County of Sarasota, State of Florida. Unless the certificate is redeemed according to law, the property described in the certificate will be sold to the highest bidder at the Sarasota County Court House, 2000 Main Street, Historic Courtroom, East Wing, Sarasota, Florida, at 9:00 a.m. on the 16TH day of NOVEMBER, 2012.

Karen E. Rushing
Clerk Of The Circuit Court
Sarasota County, Florida
By: T. Lake, Deputy Clerk
October 12, 19, 26; November 2, 2012
12-3935S

NOTICE TO CREDITORS
IN THE CIRCUIT COURT FOR SARASOTA COUNTY, FLORIDA
PROBATE DIVISION
File No. 2012 CP 003665 NC
IN RE: ESTATE OF ANTONY W. QUINN, Deceased.
The administration of the estate of ANTONY W. QUINN, deceased, whose date of death was September 17, 2012; File Number 2012 CP 003665 NC is pending in the Circuit Court for Sarasota County, Florida, Probate Division, the address of which is P.O. Box 3079, Sarasota, FL 34230. The names and addresses of the personal representatives and the personal representatives' attorney are set forth below.
All creditors of the decedent and other persons having claims or demands against decedent's estate, on whom a copy of this notice is required to be served must file their claims with

SECOND INSERTION
this court WITHIN THE LATER OF 3 MONTHS AFTER THE TIME OF THE FIRST PUBLICATION OF THIS NOTICE OR 30 DAYS AFTER THE DATE OF SERVICE OF A COPY OF THIS NOTICE ON THEM.
All other creditors of the decedent and other persons having claims or demands against decedent's estate must file their claims with this court WITHIN 3 MONTHS AFTER THE DATE OF THE FIRST PUBLICATION OF THIS NOTICE.
ALL CLAIMS NOT FILED WITHIN THE TIME PERIODS SET FORTH IN SECTION 733.702 OF THE FLORIDA PROBATE CODE WILL BE FOREVER BARRED.
NOTWITHSTANDING THE TIME PERIOD SET FORTH ABOVE, ANY CLAIM FILED TWO (2) YEARS OR MORE AFTER THE DECEDENT'S DATE OF DEATH IS BARRED.
The date of first publication of this notice is: October 5, 2012.

DAVID L. QUINN
Personal Representative
8 Broadmoor Road
Rotunda West, FL 33947
CHARLES MARGETTA, CPA
Personal Representative
1800 Second Street, Suite #745
Sarasota, FL 34236
Signed on 9/27/12.
LIVINGSTON, PATTERSON,
STRICKLAND & SIEGEL, P.A.
Attorneys for Petitioners
46 North Washington Boulevard,
Suite 1
Sarasota, FL 34236
Telephone: (941) 365-0550
By: John M. Ervin
Florida Bar No. 0048591
jervin@lpspa.com
plblair@lpspa.com
John Patterson
Florida Bar No. 0120242
jpatterson@lpspa.com
gpitts@lpspa.com
October 5, 12, 2012
12-3840S

PUBLISH YOUR LEGAL NOTICES
IN THE GULF COAST BUSINESS REVIEW

For more information, call:
(800) 403-2493 Hillsborough, Pasco
(727) 447-7784 Pinellas
(941) 906-9386 Manatee, Sarasota, Lee
(239) 594-5387 Collier
Or email: legal@review.net

GULF COAST Business Review
www.review.net

FIRST INSERTION
NOTICE OF APPLICATION FOR TAX DEED
Notice is hereby given that TRI-STATE FUNDING LLLP SAVING, the holder of the certificate listed below, has filed said certificate for a tax deed to be issued. The certificate number and year of issuance, the description of the property, and the names in which the property is assessed are as follows:

Certificate Number: 13394.000
Year of Issuance: 2009
Tax Deed File #: 12-0203 TD

Description of Property: 2005-02-0055 LOTS 13 14 & S 1/2 VAC ALLEY BAYWOOD DOC 79
Name in which the property is assessed: NANCY E ZIMMER & LYNN A ZIMMER & STEVEN J WAINUSKIS & BARBARA D WAINUSKIS
All of said property being in the County of Sarasota, State of Florida. Unless the certificate is redeemed according to law, the property described in the certificate will be sold to the highest bidder at the Sarasota County Court House, 2000 Main Street, Historic Courtroom, East Wing, Sarasota, Florida, at 9:00 a.m. on the 16TH day of NOVEMBER, 2012.

Karen E. Rushing
Clerk Of The Circuit Court
Sarasota County, Florida
By: T. Lake, Deputy Clerk
October 12, 19, 26; November 2, 2012
12-3918S

FIRST INSERTION
NOTICE OF APPLICATION FOR TAX DEED
Notice is hereby given that USAMER-IBANK MAGNOLIA TC 2 LLC, the holder of the certificate listed below, has filed said certificate for a tax deed to be issued. The certificate number and year of issuance, the description of the property, and the names in which the property is assessed are as follows:

Certificate Number: 219.000
Year of Issuance: 2010
Tax Deed File #: 12-0257 TD

Description of Property: 0025-11-0009 LOT 337 SUBJ TO RIGHT OF FLIGHT ESMT TO SARASOTA MANATEE AIRPORT AUTHORITY PER OR 3098/2224 TRI-PAR ESTATES UNIT 3
Name in which the property is assessed: SUZANNE BRICKLEY
All of said property being in the County of Sarasota, State of Florida. Unless the certificate is redeemed according to law, the property described in the certificate will be sold to the highest bidder at the Sarasota County Court House, 2000 Main Street, Historic Courtroom, East Wing, Sarasota, Florida, at 9:00 a.m. on the 16TH day of NOVEMBER, 2012.

Karen E. Rushing
Clerk Of The Circuit Court
Sarasota County, Florida
By: T. Lake, Deputy Clerk
October 12, 19, 26; November 2, 2012
12-3928S

NOTICE TO CREDITORS
IN THE CIRCUIT COURT FOR SARASOTA COUNTY, FLORIDA
PROBATE DIVISION
File No. 2012 CP 003639 NC
IN RE: ESTATE OF JOSEPH P. SIMON, JR., Deceased.
The administration of the estate of JOSEPH P. SIMON, JR., deceased, whose date of death was July 1, 2012, is pending in the Circuit Court for Sarasota County, Florida, Probate Division, the address of which is PO Box 3079, Sarasota, FL 34230. The names and addresses of the personal representatives' attorney are set forth below.
All creditors of the decedent and other persons having claims or demands against decedent's estate on whom a copy of this notice is required to be served must file their claims with this court WITHIN THE LATER OF 3 MONTHS AFTER THE TIME OF

THIRD INSERTION
THE FIRST PUBLICATION OF THIS NOTICE OR 30 DAYS AFTER THE DATE OF SERVICE OF A COPY OF THIS NOTICE ON THEM.
All other creditors of the decedent and other persons having claims or demands against decedent's estate must file their claims with this court WITHIN 3 MONTHS AFTER THE DATE OF THE FIRST PUBLICATION OF THIS NOTICE.
ALL CLAIMS NOT FILED WITHIN THE TIME PERIODS SET FORTH IN SECTION 733.702 OF THE FLORIDA PROBATE CODE WILL BE FOREVER BARRED.
NOTWITHSTANDING THE TIME PERIOD SET FORTH ABOVE, ANY CLAIM FILED TWO (2) YEARS OR MORE AFTER THE DECEDENT'S DATE OF DEATH IS BARRED.
The date of first publication of this notice is October 5, 2012.
Personal Representatives:
JOSEPH W. SIMON

44 Walworth Avenue
Scarsdale, NY 10583

LESLIE S. KNIBB
2960 Chain Bridge Road, NW
Washington, DC 20016

ERNEST W. SIMON
519 Willow Avenue, Apt. #8
Hoboken, NJ 07030
ELIZABETH C. MARSHALL
Florida Bar No. 0440884
WILLIAMS PARKER HARRISON DIETZ & GETZEN
200 S. Orange Ave.
Sarasota, FL 34236
Telephone: 941-366-4800
Designation of Email
Addresses for service:
Primary:
emarshall@williamsparke.com
Secondary:
bbird@williamsparke.com
October 5, 12, 2012
12-3873S

NOTICE OF ACTION
IN THE CIRCUIT COURT OF THE TWELFTH JUDICIAL CIRCUIT, IN AND FOR SARASOTA COUNTY, FLORIDA
COUNTY CIVIL DIVISION
CASE NO.: 2012 CC 004052
TOP REALTY GROUP OF FLORIDA LLC AS TRUSTEE FOR 855 POLARIS LAND TRUST, Plaintiff, vs.
JEAN M. SOPKO, any Unknown Person or Corporation Claiming any Interest in 855 Polaris Rd. Unit 18, Venice, Florida 34293, Defendants.
TO: JEAN M. SOPKO
LAST KNOWN ADDRESS: 855 POLARIS ROAD, UNIT 18, VENICE, FLORIDA 34293
CURRENT ADDRESS: UNKNOWN
And any unknown parties who are or may be interested in the subject matter of this action whose name and residences, after diligent search and inquiry, are unknown to Plaintiff and which said unknown parties may claim as heirs, devisees, grantees, assignees, lienors, creditors, trustees or other claimants claiming by, through, under

FOURTH INSERTION
or against the said Defendant, JEAN M. SOPKO, who is not known to be dead or alive, or any Unknown Person or Corporation Claiming any Interest in 855 Polaris Rd. Unit 18, Venice, Florida 34293.
YOU ARE HEREBY NOTIFIED that an action has been filed against you to quiet title on the following real described property in SARASOTA County, Florida, to wit:
CONDOMINIUM UNIT 4793, BUILDING 4794, SOUTH VENICE UNIT 18, ACCORDING TO THE DECLARATION OF CONDOMINIUM THEREOF, AS RECORDED IN OFFICIAL RECORDS BOOK 6, PAGE 55, OF THE PUBLIC RECORDS OF SARASOTA COUNTY, FLORIDA.
You are required to serve a copy of your written defenses, if any, to Plaintiff's attorney, Alexander Scott Dennison, Esquire, Florida Defense Law, P.A. 1227 Second Street, Sarasota, Florida, 34236, on or before thirty (30) days from Date of First Publication of this Notice and file the original with the clerk of this court either before service

on Plaintiff's attorney or immediately thereafter. If you fail to do so, a default will be entered against you for the relief demanded in the Complaint.
In accordance with the Americans With Disabilities Act, persons needing a reasonable accommodation to participate in this proceeding should contact the Clerk of the Circuit Court no later than seven business days prior to the proceeding at the Sarasota County Courthouse. Telephone 941-861-7425 (Sarasota and Venice) or 1-800-955-8770 via Florida Relay Service.
WITNESS my hand and the seal of this Court on this 10th day of September, 2012.

Karen E. Rushing
Clerk of the Court
(SEAL) By: Eva Olivia
Deputy Clerk
Attorney for Plaintiff:
Alexander Scott Dennison, Esquire
FLORIDA DEFENSE LAW, P.A.
1227 Second Street
Sarasota, Florida, 34236
Tel. (941) 706-4472
September 21, 28; October 5, 12, 2012
12-3515S

SECOND INSERTION

NOTICE OF SALE
IN THE CIRCUIT COURT OF THE
12TH JUDICIAL CIRCUIT, IN
AND FOR SARASOTA COUNTY,
FLORIDA
CIVIL DIVISION
CASE NO.: 2011 CA 005624 NC
SEC.: A

CITIMORTGAGE, INC.

Plaintiff, v.
MICHAEL ANTHONY PAYNE;
JOANN PAYNE; ANY AND ALL
UNKNOWN PARTIES CLAIMING
BY, THROUGH, UNDER, AND
AGAINST THE HEREIN NAMED
INDIVIDUAL DEFENDANT(S)
WHO ARE NOT KNOWN TO BE
DEAD OR ALIVE, WHETHER
SAID UNKNOWN PARTIES
MAY CLAIM AN INTEREST AS
SPOUSES, HEIRS, DEVISEES,
GRANTEES, OR OTHER
CLAIMANTS; MORTGAGE
ELECTRONIC REGISTRATION
SYSTEMS, INC.; AND VILLA
NOVA CONDOMINIUM
ASSOCIATION, INC.
Defendant(s).

NOTICE IS HEREBY GIVEN pursuant to an Order of Final Summary Judgment of Foreclosure dated September 18, 2012, entered in Civil Case No. 2011 CA 005624 NC of the Circuit Court of the Twelfth Judicial Circuit in and for Sarasota County, Florida, wherein the Clerk of the Circuit Court will sell to the highest bidder for cash on 23rd day of October, 2012, at 9:00 a.m. online at the website: <https://www.sarasota.realforeclose.com>, relative to the following described property as set forth in the Final Judgment, to wit:

UNIT 1724-D, VILLA NOVA,
PHASE 6, A CONDOMINIUM

ACCORDING TO THE DECLARATION OF CONDOMINIUM RECORDED IN OFFICIAL RECORDS BOOK 1306, PAGE 578, AND AMENDMENTS THERETO, AND AS PER PLAT THEREOF, RECORDED IN CONDOMINIUM BOOK 12, PAGE 35, AND AMENDMENTS THERETO OF THE PUBLIC RECORDS OF SARASOTA COUNTY, FLORIDA.

Any person claiming an interest in the surplus from the sale, if any, other than the property owner as of the date of the Lis Pendens must file a claim within 60 days after the sale.

This is an attempt to collect a debt and any information obtained may be used for that purpose.

In accordance with the Americans With Disabilities Act, persons needing a reasonable accommodation to participate in this proceeding should contact the Clerk of the Circuit Court no later than seven business days prior to the proceeding at the Sarasota County Courthouse. Telephone 941-861-7425 (Sarasota and Venice) or 1-800-955-8770 via Florida Relay Service.

MORRIS|HARDWICK|
SCHNEIDER, LLC

By: Susan Sparks, Esq., FBN: 33626
9409 Philadelphia Road
Baltimore, Maryland 21237

Mailing Address:

MORRIS|HARDWICK|SCHNEIDER
5110 Eisenhower Blvd., Suite 120
Tampa, Florida 33634
Toll Free: 1-866-503-4930
MHSinbox@closingsource.net
5764776
FL-97001133-11
October 5, 12, 2012 12-38475

NOTICE OF SALE
IN THE CIRCUIT COURT,
TWELFTH JUDICIAL CIRCUIT, IN
AND FOR SARASOTA COUNTY,
FLORIDA

CASE NO.: 2011 CA 010492 NC
Wells Fargo Bank, N.A., a national
banking association, successor by
merger to Wachovia Bank, N.A.,
successor by merger to SouthTrust
Bank,
Plaintiff, vs.

Kenneth H. White, an individual;
Kathleen B. White, an individual;
McIntosh Business Park
Condominium Association, Inc.,
a Florida non-profit corporation;
McIntosh Park of Commerce
Property Owner's Association, Inc.,
a Florida non-profit corporation;
Sarasota County, a body corporate
and politic; and Ken White Paving,
Inc., a Florida corporation,
Defendants.

Notice is given that under a Uniform Final Judgment of Mortgage Foreclosure dated September 25, 2012 in Case No. 2011-CA-010492-NC in the Circuit Court of the Twelfth Judicial Circuit in and for Sarasota County, Florida, in which Wells Fargo Bank, N.A., is Plaintiff and Kenneth H. White, Kathleen B. White, McIntosh Business Park Condominium Association, Inc., McIntosh Park of Commerce Property Owner's Association, Inc., Sarasota County, and Ken White Paving, Inc., are Defendants, the Clerk of the Court will sell to the highest and best bidder for cash online at www.sarasota.realforeclose.com, beginning at 9:00 a.m. or as soon as possible thereafter on October 29, 2012, the following described

property set forth in the Uniform Final Judgment of Mortgage Foreclosure:

SEE ATTACHED EXHIBIT "A"
EXHIBIT A

Unit K, McIntosh Business Park, an Industrial condominium according to the Declaration of Condominium recorded in Official Records Instrument No. 2000122836 and as per plat thereof recorded in Condominium Book 34, pages 30 to 30B, Public Records of Sarasota County, Florida.

TOGETHER WITH:

All buildings, structures and improvements of every nature whatsoever now or hereafter situated on the said property, and all furniture, furnishings, fixtures, machinery, equipment, inventory and materials on site, and personal property of every nature whatsoever now or hereafter owned by the Mortgagor and located in, on, or used or intended to be used in connection with or with the operation of said property, buildings, structures or other improvements, including all extensions, additions, improvements, betterments, renewals and replacements to any of the foregoing; and all of the right, title and interest of the Mortgagor in any such personal property or fixtures subject to a conditional sales contract, chattel Mortgage or

similar lien or claim together with the benefit of any deposits or payments now or hereafter made by the Mortgagor or on its behalf.

Together with all and singular the tenements, hereditaments, easements and appurtenances thereunto belonging, or in any wise appertaining, and the rents, issues, and profits thereof, and also all the estate, right, title, interest and all claims and demands whatsoever, in law as well as in equity, of said Mortgagor in and to the same, and every part and parcel thereof; and also specifically but not by way of limitation all gas and electric fixtures, heaters, water pumps, air conditioning equipment, machinery, ranges, bath tubs, sinks, water closets, water basins, pipes, faucets, and other plumbing and heating fixtures, mantels, refrigerating plants and ice boxes, window screens, screen doors, venetian blinds, cornices, storm shutters and awnings, which are now or may hereafter pertain to or be used with, in or on said premises, even though they be detached or detachable, are and shall be deemed to be fixtures and accessories to the freehold and a part of the realty.

IF YOU ARE A PERSON CLAIMING A RIGHT TO FUNDS REMAINING AFTER THE SALE, YOU MUST FILE A CLAIM WITH

THE CLERK NO LATER THAN 60 DAYS AFTER THE SALE. IF YOU FAIL TO FILE A CLAIM, YOU WILL NOT BE ENTITLED TO ANY REMAINING FUNDS. AFTER 60 DAYS, ONLY THE OWNER OF RECORD AS THE DATE OF THE LIS PENDENS MAY CLAIM THE SURPLUS.

In accordance with the Americans With Disabilities Act, persons needing a reasonable accommodation to participate in this proceeding should contact the Clerk of the Circuit Court no later than seven business days prior to the proceeding at the Sarasota County Courthouse. Telephone 941-861-7425 (Sarasota and Venice) or 1-800-955-8770 via Florida Relay Service.

Dated this 2nd day of October, 2012.

SMITH, GAMBRELL &
RUSSELL, LLP
James R. McCachren, III
Florida Bar No.: 0986585
Primary Email:
jrmccachren@sgrlaw.com
Secondary Email:
lculver@sgrlaw.com
cwilliams@sgrlaw.com
James H. Cummings
Florida Bar No. 27657
Primary Email:
jcumings@sgrlaw.com
Secondary Email:
dthall@sgrlaw.com
cwilliams@sgrlaw.com
50 N. Laura St., Suite 2600
Jacksonville, FL 32202
Telephone: (904) 598-6109
Facsimile: (904) 598-6209
Attorneys for Plaintiff,
Wells Fargo Bank, N.A.
October 5, 12, 2012 12-38205

SECOND INSERTION

NOTICE OF FORECLOSURE SALE
IN THE CIRCUIT COURT OF THE
12TH JUDICIAL CIRCUIT, IN
AND FOR SARASOTA COUNTY,
FLORIDA

CIVIL DIVISION:
CASE NO.: 2009 CA 009167 NC

THE BANK OF NEW YORK
MELLON FORMERLY KNOWN
AS THE BANK OF NEW YORK
AS SUCCESSOR TRUSTEE TO
JPMORGAN CHASE BANK,
N.A., AS TRUSTEE FOR THE
CERTIFICATEHOLDERS
OF STRUCTURED ASSET
MORTGAGE INVESTMENTS II
TRUST 2006-ARI MORTGAGE
PASS-THROUGH CERTIFICATES,
SERIES 2006-ARI,
Plaintiff, vs.
JAROSLAV HORNACEK;
FIRST HORIZON HOME LOAN
CORPORATION; KIRSTEN
PEDERSON; UNKNOWN TENANT
(S); IN POSSESSION OF THE
SUBJECT PROPERTY,
Defendant(s).

NOTICE IS HEREBY GIVEN pursuant to Final Judgment of Foreclosure dated the 18th day of September 2012 and entered in Case No. 2009 CA 009167 NC, of the Circuit Court of the 12TH Judicial Circuit in and for Sarasota County, Florida, wherein THE BANK OF NEW YORK MELLON FORMERLY KNOWN AS THE BANK OF NEW YORK AS SUCCESSOR TRUSTEE TO JPMORGAN CHASE BANK, N.A., AS TRUSTEE FOR THE CERTIFICATEHOLDERS OF STRUCTURED ASSET MORTGAGE INVESTMENTS II TRUST 2006-ARI MORTGAGE PASS-THROUGH CERTIFICATES, SERIES 2006-ARI is the Plaintiff and

JAROSLAV HORNACEK, FIRST HORIZON HOME LOAN CORPORATION, KIRSTEN PEDERSON AND UNKNOWN TENANT(S) IN POSSESSION OF THE SUBJECT PROPERTY are defendants. The Clerk of this Court shall sell to the highest and best bidder for cash electronically at www.sarasota.realforeclose.com at 9:00 AM on the 25th day of October 2012, the following described property as set forth in said Final Judgment, to wit:

LOT 8, BLOCK B, SPRINGHILL PARK, ACCORDING TO THE PLAT THEREOF RECORDED IN PLAT BOOK 5, PAGE 30, OF THE PUBLIC RECORDS OF SARASOTA COUNTY, FLORIDA. LESS; COMMENCE AT THE NORTHEAST CORNER OF SAID LOT 8, THENCE WEST ALONG NORTH LOT LINE 165 FEET, MORE OR LESS, TO THE NORTHWEST CORNER OF SAID LOT; THENCE SOUTH ALONG EASTERLY LINE OF SECOND STREET 75 FEET; THENCE EAST AND PARALLEL TO THE NORTH LOT LINE, A DISTANCE OF 165 FEET, MORE OR LESS, TO THE EASTERLY LOT LINE; THENCE NORTH TO POINT OF BEGINNING. ALSO LESS; BEGIN AT THE NORTHEAST CORNER OF LOT 7, BLOCK B, SPRINGHILL PARK, AS RECORDED IN PLAT BOOK 5, PAGE 30, OF THE PUBLIC RECORDS OF SARASOTA COUNTY, FLORIDA, THENCE NORTHWESTERLY ALONG NORTHERLY BOUNDARY OF SAID LOT 7, 206.57 FEET TO

THE MOST NORTHERLY CORNER OF SAID LOT 7; THENCE NORTHEASTERLY ALONG THE WESTERLY BOUNDARY OF LOT 8, BLOCK B, SPRINGHILL PARK SUBDIVISION, 7.3 FEET; THENCE SOUTHEASTERLY 206.75 FEET TO THE POINT OF BEGINNING.

ANY PERSON CLAIMING AN INTEREST IN THE SURPLUS FROM THE SALE, IF ANY, OTHER THAN THE PROPERTY OWNER AS OF THE DATE OF THE LIS PENDENS MUST FILE A CLAIM WITHIN 60 DAYS AFTER THE SALE.

In accordance with the Americans With Disabilities Act, persons needing a reasonable accommodation to participate in this proceeding should contact the Clerk of the Circuit Court no later than seven business days prior to the proceeding at the Sarasota County Courthouse. Telephone 941-861-7425 (Sarasota and Venice) or 1-800-955-8770 via Florida Relay Service.

Dated this 29 day of September, 2012.

By: Nicole J. Saviano, Esq.
Bar Number: 73162

Submitted by:
LAW OFFICES OF
MARSHALL C. WATSON, P.A.
1800 NW 49th Street, Suite 120
Fort Lauderdale, Florida 33309
Telephone: (954) 453-0365
Facsimile: (954) 771-6052
Toll Free: 1-800-441-2438
DESIGNATED PRIMARY E-MAIL
FOR SERVICE PURSUANT TO FLA.
R. JUD. ADMIN 2.516
eservice@marshallwatson.com
09-31942
October 5, 12, 2012 12-38075

SECOND INSERTION

NOTICE OF SALE
IN THE CIRCUIT COURT OF THE
TWELFTH JUDICIAL CIRCUIT IN
AND FOR SARASOTA
COUNTY, FLORIDA

CASE NO. 2010 CA 008369 NC
WELLS FARGO BANK, N.A.

Plaintiff, v.
THOMAS ROBERT CRONSHAW;
TASHARA AMBER CRONSHAW;
UNKNOWN TENANT 1;
UNKNOWN TENANT 2; AND ALL
UNKNOWN PARTIES CLAIMING
BY, THROUGH, UNDER OR
AGAINST THE ABOVE NAMED
DEFENDANT(S), WHO (IS/
ARE) NOT KNOWN TO BE
DEAD OR ALIVE, WHETHER
SAID UNKNOWN PARTIES
CLAIM AS HEIRS, DEVISEES,
GRANTEES, ASSIGNEES,
LIENORS, CREDITORS,
TRUSTEES, SPOUSES, OR
OTHER CLAIMANTS; WACHOVIA
BANK, N.A.
Defendants.

Notice is hereby given that, pursuant to the Summary Final Judgment of Foreclosure entered on September 24, 2012, in this cause, in the Circuit Court of Sarasota County, Florida, the clerk shall sell the property situated in Sarasota County, Florida, described as:

A PART OF LOTS 1, 2, 5 AND 6, BLOCK R, PLAT OF ENGLEWOOD, AS PER PLAT THEREOF RECORDED IN PLAT BOOK A, PAGE 29, PUBLIC RECORDS OF SARASOTA COUNTY, FLORIDA, BEING MORE PARTICULARLY DESCRIBED AS FOLLOWS: THE E 47 FEET OF LOT 1, BLOCK R AND THE W 87 FEET OF LOT 5, BLOCK R, AND

THEN 1/2 OF THE W 87 FEET OF LOT 6, BLOCK R, TOGETHER WITH A TRIANGULAR PART OF LOT 2, BLOCK R, BEING DESCRIBED AS FOLLOWS:

COMMENCE AT THE NE CORNER OF ABOVE DESCRIBED LOT 2 FOR A P.O.B.; RUN THENCE WESTERLY ALONG THE BOUNDARY LINE OF SAID LOT 2, 47 FEET TO THE SW CORNER OF THE E 47 FEET OF SAID LOT 1; THENCE SOUTHEASTERLY 84.28 FEET TO THE SW CORNER OF THE N 1/2, OF SAID LOT 6; THENCE NORTHERLY ALONG THE EASTERLY BOUNDARY LINE OF SAID LOT 2, 70 FEET TO THE P.O.B. TOGETHER WITH:

PART OF LOT 1, BLOCK R, PLAT OF ENGLEWOOD, AS PER PLAT THEREOF RECORDED IN PLAT BOOK A, PAGE 29, PUBLIC RECORDS OF SARASOTA COUNTY, FLORIDA, DESCRIBED AS FOLLOWS: STARTING AT A FIXED STAKE 180 FEET IN AN EASTERLY DIRECTION FROM THE NW CORNER OF SAID LOT 1; THENCE 139 FEET, MORE OR LESS IN A SOUTHERLY DIRECTION TO A STAKE; THENCE EASTERLY 50 FEET TO A STAKE; THENCE 139 FEET MORE OR LESS, TO A STAKE AND WENTWORTH STREET IN A NORTHERLY DIRECTION; THENCE ALONG WENTWORTH STREET, 50 FEET TO THE POINT OF BE-

GINNING. TOGETHER WITH THE WEST 87 FEET OF LOT 5, BLOCK R, PLAT OF ENGLEWOOD, AS PER PLAT THEREOF RECORDED IN PLAT BOOK A, PAGE 29, OF THE PUBLIC RECORDS OF SARASOTA COUNTY, FLORIDA.

a/k/a 449 W. WENTWORTH ST., ENGLEWOOD, FL 34223 at public sale, to the highest and best bidder, for cash, online at www.sarasota.realforeclose.com, Sarasota County, Florida, on October 30, 2012 at 09:00 AM.

Any person claiming an interest in the surplus from the sale, if any, other than the property owner as of the date of the lis pendens must file a claim within 60 days after the sale.

In accordance with the Americans With Disabilities Act, persons needing a reasonable accommodation to participate in this proceeding should contact the Clerk of the Circuit Court no later than seven business days prior to the proceeding at the Sarasota County Courthouse. Telephone 941-861-7425 (Sarasota and Venice) or 1-800-955-8770 via Florida Relay Service.

Dated at St. Petersburg, Florida, this 2 day of October, 2012.

Karen E. Rushing
Clerk of the Circuit Court
/s/ Tara M. McDonald, Esquire
Tara M. McDonald, Esquire
Florida Bar No. 43941

DOUGLAS C. ZAHM, P.A.
12425 28th Street North, Suite 200
St. Petersburg, FL 33716
Telephone No. (727) 536-4911
Fax No. (727) 539-1094
Attorney for Plaintiff
888101375
October 5, 12, 2012 12-38655

SECOND INSERTION

NOTICE OF JUDICIAL SALE
PURSUANT TO §45.031, P.L. STAT.
IN THE CIRCUIT COURT OF THE
TWELFTH JUDICIAL CIRCUIT IN
AND FOR SARASOTA COUNTY,
FLORIDA

CASE NO.: 2009CA013486NC
2222 TAMiami TRAIL, LLC,
a Florida limited liability company,
Plaintiff, vs.

BLUE SIESTA, L.L.C., a Florida
limited liability company, et al.,
Defendants.

To Defendants BLUE SIESTA, L.L.C., a Florida limited liability company, JOHN A. LIERANCE, an individual, BLUE SIESTA REALTY, L.L.C., a Florida limited liability company, THE CENTER FOR ADVANCED WELLNESS NORTH, LLC, a Florida limited liability company, J.P. PETERSON, LLC, a Florida limited liability company, THE CENTER FOR ADVANCED WELLNESS, L.L.C., a Florida limited liability company, CAMBRIDGE CLINIC, P.L., a Florida limited liability company, CAMBRIDGE CLINIC NORTH, P.L., a Florida limited liability company, PHYSICIAN SERVICES OF SARASOTA, INC., a Florida corporation, DR. JOHN A. LIEURANCE, P.A., a Florida corporation, PAM LIEURANCE, an individual, and JOHN DOE 1, and JANE DOE 1, and all others whom it may concern:

Notice is hereby given that pursuant to the Final Judgment of Fore-

closure entered on June 21, 2012, in Case No.: 2009CA013486NC in the Circuit Court of the Twelfth Judicial Circuit in and for Sarasota County, Florida, in which 2222 TAMiami TRAIL, LLC, 20 N. Orange Ave., Suite 1600, Orlando FL 32801, is the Plaintiff, and BLUE SIESTA, L.L.C., et al., are the Defendants, that the Clerk shall offer for sale the following described real property located in Sarasota County:

Lots 42, 43 and 44, Block C, DESOTA PARK, according to the plat thereof recorded in Plat Book 1, Page 61, of the Public Records of Sarasota County, Florida, LESS that portion for Road Right-of-Way ("Land");

which includes all and singular the tenements, hereditaments, appurtenances, privileges, rights, interests, dower, reversions, remainders, easements, and all structures and improvements of every kind and description appertaining to the

Land all of which, together with all of the personal property, fixtures and intangibles associated with, relating to, or appertaining to the use and occupancy of the Land, including but not

limited to: (a) all structures and improvements now or hereafter on the Land; (b) all right, title, and interest of Blue Siesta, L.L.C. to the minerals, soil, flowers, shrubs, crops, trees, timber, emblems and other products now or hereafter on, under or above the Land, or any part or parcel thereof; (c) all of Blue Siesta, L.L.C.'s right, title, interest, and privileges arising under all contracts and permits entered into or obtained in connection with the development or operation of the Land, including by way of example and not in limitation: all development and construction permits, approvals, resolutions, variances, licenses, and franchises granted by municipal, county, state, and federal governmental authorities, or any of their respective agencies; all architectural, engineering, and construction contracts; all drawings, plans, specifications and plats; and all contracts and agreements for the furnishing of utilities; (d) all of Blue Siesta, L.L.C.'s interest in all utility security deposits or bonds now or hereafter deposited in connection with the Land; (e) all of Blue Siesta, L.L.C.'s interest as lessor in and to all leases or rental arrangements now or hereafter

affecting all or any part of the Land and all other rents and profits derived from the Land, all income or proceeds from the development of or economic activity upon any part of the Land; (f) all of Blue Siesta, L.L.C.'s interest in and to any and all contracts and agreements for the sale of the Land, or any part thereof or any interest therein, whether now existing or arising hereafter, and all of Blue Siesta, L.L.C.'s interest in and right to earnest money deposits made upon such contracts and agreements; (g) all land improvements to and upon the Land, including water, sanitary, and storm sewer systems, and all related equipment and appurtenances thereto, whether now existing or hereafter located in, upon, over or under the Land; (h) all machinery, apparatus, equipment, fittings, and fixtures, whether actually or constructively attached to the Land, and all trade, domestic, and ornamental fixtures, and articles of personal property of every kind and nature whatsoever now or hereafter located in, upon, over or under the Land, or any part thereof, and used or usable in connection with any present or future operation or development of the Land, and now owned or

hereafter acquired by Blue Siesta, L.L.C., including by way of example and not in limitation: heating, air conditioning, freezing, lighting, laundry, incinerating, and power equipment; engines, pipes, wells, water filtering systems and softening devices, water heaters, pumps, tanks, and motors; all swimming pools and appurtenances thereto; all electrical and plumbing installations; all furniture, furnishings, wall and floor coverings, blinds, elevators, appliances, television antennas and cables, storm and screen windows and doors, and lighting fixtures; all building materials and equipment now or hereafter delivered to the Land or stored at an off-site location; and (i) all right, title and interest of Blue Siesta, L.L.C. in and to all unearned premiums accrued, accruing, or to accrue under any and all insurance policies now or hereafter existing which covers all or any portion of the Land; all proceeds or sums payable for the loss of or damage to all or any portion of the Land; all payments received under warranties applicable to all or any portion of the Land; and any other amounts received in satisfaction of claims for defects in all or any portion of the Land, which includes all

buildings and improvements, if any, situated upon said Land.

The above property will be sold on October 18, 2012, at 9:00 a.m., or as soon as possible thereafter, to the highest and best bidder for cash at www.sarasota.realforeclose.com, in accordance with 45.031, Fla. Stat. Any person claiming an interest in the surplus from the sale, if any, other than the property owner as of the date of the Lis Pendens must file a claim within sixty (60) days after the sale.

In accordance with the Americans With Disabilities Act, persons needing a reasonable accommodation to participate in this proceeding should contact the Clerk of the Circuit Court no later than seven business days prior to the proceeding at the Sarasota County Courthouse. Telephone 941-861-7425 (Sarasota and Venice) or 1-800-955-8770 via Florida Relay Service.

DATED this 26th day of September, 2012.

WINDERWEEDLE, HAINES,
WARD & WOODMAN, P.A.
390 N. Orange Avenue, Suite 1500
Post Office Box 1391
Orlando, FL 32802-1391
(407) 423-4246
(407) 423-7014 (Fax)
Attorneys for Plaintiff
/s/ Michael C. Caborn, Esquire
Florida Bar No. 0162477
October 5, 12, 2012 12-37885

SECOND INSERTION

NOTICE OF SALE
IN THE CIRCUIT COURT OF THE
TWELFTH JUDICIAL CIRCUIT IN
AND FOR SARASOTA
COUNTY, FLORIDA

CASE NO. 2010 CA 010331 NC
US BANK, NA
Plaintiff, v.
ANNETTE R. CALO; UNKNOWN
SPOUSE OF ANNETTE R.
CALO; UNKNOWN TENANT 1;
UNKNOWN TENANT 2; AND
ALL UNKNOWN PARTIES
CLAIMING BY, THROUGH,
UNDER OR AGAINST THE ABOVE
NAMED DEFENDANT(S), WHO
(IS/ARE) NOT KNOWN TO BE
DEAD OR ALIVE, WHETHER
SAID UNKNOWN PARTIES
CLAIM AS HEIRS, DEVISEES,
GRANTEES, ASSIGNEES,
LIENORS, CREDITORS,
TRUSTEES, SPOUSES, OR
OTHER CLAIMANTS; CITY
OF SARASOTA, FLORIDA, A
MUNICIPAL CORPORATION;
FLORIDA HOUSING FINANCE
CORPORATION; SUNTRUST
MORTGAGE, INC.
Defendants.

Notice is hereby given that, pursuant to the Summary Final Judgment of Foreclosure entered on September 24, 2012, in this cause, in the Circuit Court of Sarasota County, Florida, the clerk shall sell the property situated in Sarasota County, Florida, described as:

THE EAST 10 FEET OF LOT
15479 AND LOTS 15480 ABD
15481, UNIT 59, SOUTH VENICE,
ACCORDING TO THE
PLAT THEREOF, RECORDED
IN PLAT BOOK 7, PAGE 31, OF
THE PUBLIC RECORDS OF
SARASOTA COUNTY,
FLORIDA.

a/k/a 132 EAST BAFFIN DRIVE,
VENICE, FL 34293-3507

at public sale, to the highest and best bidder, for cash, online at www.sarasota.realforeclose.com, Sarasota County, Florida, on October 30, 2012 at 09:00 AM.

Any person claiming an interest in the surplus from the sale, if any, other than the property owner as of the date of the lis pendens must file a claim within 60 days after the sale.

In accordance with the Americans With Disabilities Act, persons needing a reasonable accommodation to participate in this proceeding should contact the Clerk of the Circuit Court no later than seven business days prior to the proceeding at the Sarasota County Courthouse. Telephone 941-861-7425 (Sarasota and Venice) or 1-800-955-8770 via Florida Relay Service.

Dated at St. Petersburg, Florida, this 2 day of October, 2012.

Karen E. Rushing
Clerk of the Circuit Court
s\ Tara M. McDonald, Esquire
Tara M. McDonald, Esquire
Florida Bar No. 43941
DOUGLAS C. ZAHM, P.A.
12425 28th Street North, Suite 200
St. Petersburg, FL 33716
Telephone No. (727) 536-4911
Fax No. (727) 539-1094
Attorney for Plaintiff
665101298
October 5, 12, 2012 12-3863S

SECOND INSERTION

NOTICE OF FORECLOSURE SALE
IN THE CIRCUIT COURT OF THE
12TH JUDICIAL CIRCUIT, IN
AND FOR SARASOTA COUNTY,
FLORIDA

CIVIL DIVISION:
CASE NO.: 2010CA012135NC
GMAC MORTGAGE, LLC,
Plaintiff, vs.
HOLLY PARKS A/K/A HOLLY
E HAND; SUNTRUST BANK;
UNKNOWN SPOUSE OF HOLLY
E PARKS A/K/A HOLLY E HAND;
UNKNOWN TENANT (S); IN
POSSESSION OF THE SUBJECT
PROPERTY,
Defendants.

NOTICE IS HEREBY GIVEN pursuant to Final Judgment of Foreclosure dated the 18th day of September, 2012, and entered in Case No. 2010CA012135NC, of the Circuit Court of the 12TH Judicial Circuit in and for Sarasota County, Florida, wherein GMAC MORTGAGE, LLC is the Plaintiff and HOLLY PARKS A/K/A HOLLY E HAND; SUNTRUST BANK; UNKNOWN SPOUSE OF HOLLY E PARKS N/K/A PATRICK PARKS; UNKNOWN TENANT N/K/A KARI HASSAL; UNKNOWN TENANT (S); IN POSSESSION OF THE SUBJECT PROPERTY are defendants. The Clerk of this Court shall sell to the highest and best bidder for cash electronically at www.sarasota.realforeclose.com at, 9:00 AM on the 26th day of October, 2012, the following described property as set forth in said Final Judgment, to wit:

LOT 1, BLOCK 799, 19TH ADDITION TO PORT CHARLOTTE SUBDIVISION, ACCORDING TO THE PLAT THEREOF RECORDED IN PLAT BOOK 14, PAGE 7, OF THE PUBLIC RECORDS OF SARASOTA COUNTY, FLORIDA.

ANY PERSON CLAIMING AN INTEREST IN THE SURPLUS FROM THE SALE, IF ANY, OTHER THAN THE PROPERTY OWNER AS OF THE DATE OF THE LIS PENDENS MUST FILE A CLAIM WITHIN 60 DAYS AFTER THE SALE.

In accordance with the Americans With Disabilities Act, persons needing a reasonable accommodation to participate in this proceeding should contact the Clerk of the Circuit Court no later than seven business days prior to the proceeding at the Sarasota County Courthouse. Telephone 941-861-7425 (Sarasota and Venice) or 1-800-955-8770 via Florida Relay Service.

Dated this 01 day of OCTOBER, 2012.

By: Michelle Zelina, Esq.
Bar Number: 85613

Submitted by:
LAW OFFICES OF
MARSHALL C. WATSON, P.A.
1800 NW 49th Street, Suite 120
Fort Lauderdale, Florida 33309
Telephone: (954) 453-0365
Facsimile: (954) 771-6052
Toll Free: 1-800-441-2438
DESIGNATED PRIMARY E-MAIL
FOR SERVICE PURSUANT TO FLA.
R. JUD. ADMIN 2.516
eservice@marshallwatson.com
10-32714
October 5, 12, 2012 12-3836S

SECOND INSERTION

NOTICE OF FORECLOSURE SALE
IN THE CIRCUIT COURT OF THE
12TH JUDICIAL CIRCUIT, IN
AND FOR SARASOTA COUNTY,
FLORIDA

CIVIL DIVISION:
CASE NO.: 58-2010-CA-005174 NC
GMAC MORTGAGE, LLC,
Plaintiff, vs.
STEVEN FARRELL; SUZANNE
FARRELL; KEY BANK,
N.A.; PREMIER MORTGAGE
FUNDING, INC., A DISSOLVED
CORPORATION; UNKNOWN
TENANT (S); IN POSSESSION OF
THE SUBJECT PROPERTY,
Defendants.

NOTICE IS HEREBY GIVEN pursuant to Final Judgment of Foreclosure dated the 18th day of September, 2012, and entered in Case No. 58-2010-CA-005174 NC, of the Circuit Court of the 12TH Judicial Circuit in and for Sarasota County, Florida, wherein GMAC MORTGAGE, LLC is the Plaintiff and STEVEN FARRELL; SUZANNE FARRELL; KEY BANK, N.A.; PREMIER MORTGAGE FUNDING, INC., A DISSOLVED CORPORATION; UNKNOWN TENANT N/K/A HEATHER E. LAVOIE; UNKNOWN TENANT (S); IN POSSESSION OF THE SUBJECT PROPERTY are defendants. The Clerk of this Court shall sell to the highest and best bidder for cash electronically at www.sarasota.realforeclose.com at, 9:00 AM on the 26th day of October, 2012, the following described property as set forth in said Final Judgment, to wit:

LOT 14, BLOCK 470, 8TH ADDITION TO PORT CHARLOTTE SUBDIVISION, A SUBDIVISION ACCORDING TO THE PLAT THEREOF, RECORDED IN PLAT BOOK 12, PAGES 20, 20A THROUGH 20Z, INCLUSIVE, PUBLIC RECORDS OF SARASOTA COUNTY, FLORIDA.

ANY PERSON CLAIMING AN INTEREST IN THE SURPLUS FROM THE SALE, IF ANY, OTHER THAN THE PROPERTY OWNER AS OF THE DATE OF THE LIS PENDENS MUST FILE A CLAIM WITHIN 60 DAYS AFTER THE SALE.

In accordance with the Americans With Disabilities Act, persons needing a reasonable accommodation to participate in this proceeding should contact the Clerk of the Circuit Court no later than seven business days prior to the proceeding at the Sarasota County Courthouse. Telephone 941-861-7425 (Sarasota and Venice) or 1-800-955-8770 via Florida Relay Service.

Dated this 01 day of OCTOBER, 2012.

By: Michelle Zelina, Esq.
Bar Number: 85613

Submitted by:
LAW OFFICES OF
MARSHALL C. WATSON, P.A.
1800 NW 49th Street, Suite 120
Fort Lauderdale, Florida 33309
Telephone: (954) 453-0365
Facsimile: (954) 771-6052
Toll Free: 1-800-441-2438
DESIGNATED PRIMARY E-MAIL
FOR SERVICE PURSUANT TO FLA.
R. JUD. ADMIN 2.516
eservice@marshallwatson.com
10-16220
October 5, 12, 2012 12-3835S

SECOND INSERTION

NOTICE OF FORECLOSURE SALE
IN THE CIRCUIT COURT OF THE
12TH JUDICIAL CIRCUIT, IN
AND FOR SARASOTA COUNTY,
FLORIDA

CIVIL DIVISION:
CASE NO.: 2011 CA 003165 NC
FANNIE MAE ("FEDERAL
NATIONAL MORTGAGE
ASSOCIATION"),
Plaintiff, vs.
RONDA MORADO A/K/A RONDA
L MORADO AKA RONDA LEE
MORADO; UNKNOWN
TENANT (S); IN POSSESSION OF
THE SUBJECT PROPERTY,
Defendants.

NOTICE IS HEREBY GIVEN pursuant to Final Judgment of Foreclosure dated the 18th day of September, 2012, and entered in Case No. 2011 CA 003165 NC, of the Circuit Court of the 12TH Judicial Circuit in and for Sarasota County, Florida, wherein FANNIE MAE ("FEDERAL NATIONAL MORTGAGE ASSOCIATION") is the Plaintiff and RONDA MORADO A/K/A RONDA L MORADO AKA RONDA LEE MORADO; UNKNOWN TENANT N/K/A KATIE G. GONZALEZ; UNKNOWN TENANT (S); IN POSSESSION OF THE SUBJECT PROPERTY are defendants. The Clerk of this Court shall sell to the highest and best bidder for cash electronically at www.sarasota.realforeclose.com at, 9:00 AM on the 26th day of October, 2012, the following described property as set forth in said Final Judgment, to wit:

LOT 12, BLOCK 2076, 45TH ADDITION TO PORT CHARLOTTE SUBDIVISION, ACCORDING TO THE PLAT THEREOF, RECORDED IN PLAT BOOK 19, PAGES 38, 38A THROUGH 38GG, INCLUSIVE, OF THE PUBLIC RECORDS OF SARASOTA COUNTY, FLORIDA.

ANY PERSON CLAIMING AN INTEREST IN THE SURPLUS FROM THE SALE, IF ANY, OTHER THAN THE PROPERTY OWNER AS OF THE DATE OF THE LIS PENDENS MUST FILE A CLAIM WITHIN 60 DAYS AFTER THE SALE.

In accordance with the Americans With Disabilities Act, persons needing a reasonable accommodation to participate in this proceeding should contact the Clerk of the Circuit Court no later than seven business days prior to the proceeding at the Sarasota County Courthouse. Telephone 941-861-7425 (Sarasota and Venice) or 1-800-955-8770 via Florida Relay Service.

Dated this 1 day of October, 2012.

By: Elisabeth Porter, Esq.
Bar Number: 645648

Submitted by:
LAW OFFICES OF
MARSHALL C. WATSON, P.A.
1800 NW 49th Street, Suite 120
Fort Lauderdale, Florida 33309
Telephone: (954) 453-0365
Facsimile: (954) 771-6052
Toll Free: 1-800-441-2438
DESIGNATED PRIMARY E-MAIL
FOR SERVICE PURSUANT TO FLA.
R. JUD. ADMIN 2.516
eservice@marshallwatson.com
10-35981
October 5, 12, 2012 12-3832S

SECOND INSERTION

NOTICE OF FORECLOSURE SALE
IN THE CIRCUIT COURT OF THE
12TH JUDICIAL CIRCUIT, IN
AND FOR SARASOTA COUNTY,
FLORIDA

CIVIL DIVISION:
CASE NO.: 2009 CA 012541 NC
DEUTSCHE BANK NATIONAL
TRUST COMPANY, AS TRUSTEE
FOR MORGAN STANLEY HOME
EQUITY LOAN TRUST 2006-3,
MORTGAGE PASS-THROUGH
CERTIFICATES, SERIES 2006-3,
Plaintiff, vs.
DENNEL RICH; ARNOLD RICH;
UNKNOWN TENANT (S); IN
POSSESSION OF THE SUBJECT
PROPERTY,
Defendant(s).

NOTICE IS HEREBY GIVEN pursuant to Final Judgment of Foreclosure dated the 18th day of September 2012 and entered in Case No. 2009 CA 012541 NC, of the Circuit Court of the 12TH Judicial Circuit in and for Sarasota County, Florida, wherein DEUTSCHE BANK NATIONAL TRUST COMPANY, AS TRUSTEE FOR MORGAN STANLEY HOME EQUITY LOAN TRUST 2006-3, MORTGAGE PASS-THROUGH CERTIFICATES, SERIES 2006-3 is the Plaintiff and DENNEL RICH, ARNOLD RICH and UNKNOWN TENANT(S) IN POSSESSION OF THE SUBJECT PROPERTY are defendants. The Clerk of this Court shall sell to the highest and best bidder for cash electronically at www.sarasota.realforeclose.com at, 9:00 AM on the 25th day of October 2012 the following described property as set forth in said Final Judgment, to wit:

LOT 89, RIDGEWOOD ESTATES, 5TH ADDITION, ACCORDING TO THE PLAT THEREOF RECORDED IN PLAT BOOK 13, PAGE 11, OF THE PUBLIC RECORDS OF SARASOTA COUNTY, FLORIDA

ANY PERSON CLAIMING AN INTEREST IN THE SURPLUS FROM THE SALE, IF ANY, OTHER THAN THE PROPERTY OWNER AS OF THE DATE OF THE LIS PENDENS MUST FILE A CLAIM WITHIN 60 DAYS AFTER THE SALE.

In accordance with the Americans With Disabilities Act, persons needing a reasonable accommodation to participate in this proceeding should contact the Clerk of the Circuit Court no later than seven business days prior to the proceeding at the Sarasota County Courthouse. Telephone 941-861-7425 (Sarasota and Venice) or 1-800-955-8770 via Florida Relay Service.

Dated this 29 day of September, 2012.

Nicole J. Saviano, Esq.
Bar Number: 73162

Submitted by:
LAW OFFICES OF
MARSHALL C. WATSON, P.A.
1800 NW 49th Street, Suite 120
Fort Lauderdale, Florida 33309
Telephone: (954) 453-0365
Facsimile: (954) 771-6052
Toll Free: 1-800-441-2438
DESIGNATED PRIMARY E-MAIL
FOR SERVICE PURSUANT TO FLA.
R. JUD. ADMIN 2.516
eservice@marshallwatson.com
09-46955
October 5, 12, 2012 12-3815S

SECOND INSERTION

NOTICE OF SALE
PURSUANT TO CHAPTER 45
IN THE CIRCUIT COURT OF THE
TWELFTH JUDICIAL CIRCUIT
IN AND FOR SARASOTA COUNTY,
FLORIDA

CIVIL DIVISION
CASE NO. 2010 CA 005945 NC
Division No. C
BANK OF AMERICA, N.A.
Plaintiff(s), vs.
ELIZABETH BARNETT A/K/A
ELIZABETH K. BARNETT; et al.,
Defendant(s)

NOTICE IS HEREBY GIVEN pursuant to an Order or Final Judgment of Foreclosure dated September 18, 2012, and entered in Case 2010 CA 005945 NC of the Circuit Court of the 12TH Judicial Circuit in and for SARASOTA County, Florida, wherein BANK OF AMERICA, N.A. is the Plaintiff and , ELIZABETH BARNETT A/K/A ELIZABETH K. BARNETT; and LAKES OF CAPRI CONDOMINIUM ASSOCIATION, INC; and BANK OF AMERICA, N.A. are the Defendants, the clerk shall sell to the highest and best bidder for cash www.sarasota.realforeclose.com, the Clerk's website for on-line auctions, at 9:00 A.M. on the 16 day of January, 2012, the following described property as set forth in said Order of Final Judgment, to wit:

UNIT 215, LAKES OF CAPRI CONDOMINIUM, A CONDOMINIUM ACCORDING TO THE DECLARATION OF CONDOMINIUM RECORDED IN OFFICIAL RECORDS BOOK 1631, PAGE 261, AND AMENDMENTS THERETO, AND AS PER PLAT THEREOF, RECORDED IN CONDOMINIUM BOOK 21, PAGE 21, AND AMENDMENTS THERETO OF THE PUBLIC RECORDS OF SARASOTA COUNTY, FLORIDA.

IF YOU ARE A PERSON CLAIMING A RIGHT TO FUNDS REMAINING AFTER THE SALE, YOU MUST FILE A CLAIM WITH THE CLERK OF COURT NO LATER THAN 60 DAYS AFTER THE SALE. IF YOU FAIL TO FILE A CLAIM, YOU WILL NOT BE ENTITLED TO ANY REMAINING FUNDS. AFTER 60 DAYS, ONLY THE OWNER OF RECORD AS OF THE DATE OF THE LIS PENDENS MAY CLAIM THE SURPLUS.

In accordance with the Americans With Disabilities Act, persons needing a reasonable accommodation to participate in this proceeding should contact the Clerk of the Circuit Court no later than seven business days prior to the proceeding at the Sarasota County Courthouse. Telephone 941-861-7425 (Sarasota and Venice) or 1-800-955-8770 via Florida Relay Service.

DATED this 27 day of September, 2012.

By: /s/ Lisa Wysong
Lisa N. Wysong, Esq./
Florida Bar # 521671

GILBERT GARCIA GROUP, P.A.
Attorney for Plaintiff(s)
2005 Pan Am Circle, Suite 110
Tampa, Florida 33607
(813) 443-5087
emailservice@gilbertgrouplaw.com
972233.000366/NS
October 5, 12, 2012 12-3769S

SECOND INSERTION

NOTICE OF SALE
IN THE CIRCUIT COURT OF THE
TWELFTH JUDICIAL CIRCUIT IN
AND FOR SARASOTA
COUNTY, FLORIDA

CASE NO. 2010 CA 010508 NC
INTERSTATE ADVISORS, LLC
Plaintiff, v.

GREISY S. MARTINEZ;
ROSA GUTIERREZ; SABINO
MARTINEZ; UNKNOWN SPOUSE
OF GREISY S. MARTINEZ;
UNKNOWN SPOUSE OF ROSA
GUTIERREZ; UNKNOWN
SPOUSE OF SABINO MARTINEZ;
UNKNOWN TENANT 1;
UNKNOWN TENANT 2; AND ALL
UNKNOWN PARTIES CLAIMING
BY, THROUGH, UNDER OR
AGAINST THE ABOVE NAMED
DEFENDANT(S), WHO (IS/
ARE) NOT KNOWN TO BE
DEAD OR ALIVE, WHETHER
SAID UNKNOWN PARTIES
CLAIM AS HEIRS, DEVISEES,
GRANTEES, ASSIGNEES,
LIENORS, CREDITORS,
TRUSTEES, SPOUSES, OR OTHER
CLAIMANTS; HIDDEN LAKE
VILLAGE OF SARASOTA, INC.
Defendants.

Notice is hereby given that, pursuant to the Summary Final Judgment of Foreclosure entered on September 24, 2012, in this cause, in the Circuit Court of Sarasota County, Florida, the clerk shall sell the property situated in Sarasota County, Florida, described as:

UNIT 2702-A, HIDDEN LAKE VILLAGE, A CONDOMINIUM, ACCORDING TO THE DECLARATION OF CONDOMINIUM RECORDED IN OFFICIAL RECORDS BOOK 1368, PAGE 1482, AND AMENDMENTS

THERETO, AND AS PER PLAT THEREOF, RECORDED IN CONDOMINIUM BOOK 14, PAGE 16 AND AMENDMENTS THERETO OF THE PUBLIC RECORDS OF SARASOTA COUNTY, FLORIDA.

a/k/a 2702 HIDDEN LAKE DRIVE S., UNIT A, SARASOTA, FL 34237

at public sale, to the highest and best bidder, for cash, online at www.sarasota.realforeclose.com, Sarasota County, Florida, on October 30, 2012 at 09:00 AM.

Any person claiming an interest in the surplus from the sale, if any, other than the property owner as of the date of the lis pendens must file a claim within 60 days after the sale.

In accordance with the Americans With Disabilities Act, persons needing a reasonable accommodation to participate in this proceeding should contact the Clerk of the Circuit Court no later than seven business days prior to the proceeding at the Sarasota County Courthouse. Telephone 941-861-7425 (Sarasota and Venice) or 1-800-955-8770 via Florida Relay Service.

Dated at St. Petersburg, Florida, this 2 day of October, 2012.

Karen E. Rushing
Clerk of the Circuit Court
s\ Tara M. McDonald, Esquire
Tara M. McDonald, Esquire
Florida Bar No. 43941
DOUGLAS C. ZAHM, P.A.
12425 28th Street North, Suite 200
St. Petersburg, FL 33716
Telephone No. (727) 536-4911
Fax No. (727) 539-1094
Attorney for Plaintiff
525100015
October 5, 12, 2012 12-3860S

SECOND INSERTION

NOTICE OF FORECLOSURE SALE
IN THE CIRCUIT COURT OF THE
12TH JUDICIAL CIRCUIT, IN
AND FOR SARASOTA COUNTY,
FLORIDA

CIVIL DIVISION:
CASE NO.: 58-2010-CA-002068 NC
GMAC MORTGAGE LLC,
Plaintiff, vs.

WILLIAM W FARLEY A/K/A
WILLIAM FARLEY; SKIPPI
FARLEY; UNKNOWN
TENANT (S); IN POSSESSION OF
THE SUBJECT PROPERTY,
Defendants.

NOTICE IS HEREBY GIVEN pursuant to Final Judgment of Foreclosure dated the 18th day of September, 2012, and entered in Case No. 58-2010-CA-002068 NC, of the Circuit Court of the 12TH Judicial Circuit in and for Sarasota County, Florida, wherein GMAC MORTGAGE LLC is the Plaintiff and WILLIAM W FARLEY A/K/A WILLIAM FARLEY; SKIPPI FARLEY; UNKNOWN TENANT N/K/A DAVID G. MANN; UNKNOWN TENANT (S); IN POSSESSION OF THE SUBJECT PROPERTY are defendants. The Clerk of this Court shall sell to the highest and best bidder for cash electronically at www.sarasota.realforeclose.com at, 9:00 AM on the 26th day of October, 2012, the following described property as set forth in said Final Judgment, to wit:

TRACT O, FORTY-NINTH ADDITION TO PORT CHARLOTTE SUBDIVISION, ACCORDING TO THE PLAT THEREOF RECORDED IN PLAT BOOK 21, PAGES 1, 1A THROUGH 11T, OF THE PUBLIC RECORDS OF SARASOTA COUNTY, FLORIDA. LESS THEREFROM THAT CERTAIN PARCEL CONVEYED IN WAR-

RANTY DEED RECORDED IN OFFICIAL RECORDS INSTRUMENT NO. 2000007370, OF THE PUBLIC RECORDS OF SARASOTA COUNTY, FLORIDA. TOGETHER WITH ALL THE TENEMENTS, HEREDITAMENTS AND APPURTENANCES THERETO BELONGING OR IN ANYWISE APPERTAINING.

ANY PERSON CLAIMING AN INTEREST IN THE SURPLUS FROM THE SALE, IF ANY, OTHER THAN THE PROPERTY OWNER AS OF THE DATE OF THE LIS PENDENS MUST FILE A CLAIM WITHIN 60 DAYS AFTER THE SALE.

In accordance with the Americans With Disabilities Act, persons needing a reasonable accommodation to participate in this proceeding should contact the Clerk of the Circuit Court no later than seven business days prior to the proceeding at the Sarasota County Courthouse. Telephone 941-861-7425 (Sarasota and Venice) or 1-800-955-8770 via Florida Relay Service.

Dated this 01 day of OCTOBER, 2012.

By: Michelle Zelina, Esq.
Bar Number: 85613

Submitted by:
LAW OFFICES OF
MARSHALL C. WATSON, P.A.
1800 NW 49th Street, Suite 120
Fort Lauderdale, Florida 33309
Telephone: (954) 453-0365
Facsimile: (954) 771-6052
Toll Free: 1-800-441-2438
DESIGNATED PRIMARY E-MAIL
FOR SERVICE PURSUANT TO FLA.
R. JUD. ADMIN 2.516
eservice@marshallwatson.com
10-10615
October 5, 12, 2012 12-3834S

NOTICE OF FORECLOSURE SALE
IN THE CIRCUIT COURT OF THE
12TH JUDICIAL CIRCUIT, IN
AND FOR SARASOTA COUNTY,
FLORIDA

CIVIL DIVISION:
CASE NO.: 2009 CA 015609 NC
CITIBANK, N.A., AS TRUSTEE
FOR CERTIFICATEHOLDERS
OF STRUCTURED ASSET
MORTGAGE INVESTMENTS II
TRUST 2007-AR6, MORTGAGE
PASS-THROUGH CERTIFICATES,
SERIES 2007-AR6,
Plaintiff, vs.

NEHEMAN A JALLER A/K/A
NEHEMAN ALBERTO JALLER;
UNKNOWN TENANT (S); IN
POSSESSION OF THE SUBJECT
PROPERTY
Defendant(s).

NOTICE IS HEREBY GIVEN pursuant to Final Judgment of Foreclosure dated the 18th day of September 2012 and entered in Case No. 2009 CA 015609 NC, of the Circuit Court of the 12TH Judicial Circuit in and for Sarasota County, Florida, wherein CITIBANK, N.A., AS TRUSTEE FOR CERTIFICATEHOLDERS OF STRUCTURED ASSET MORTGAGE INVESTMENTS II TRUST 2007-AR6, MORTGAGE PASS-THROUGH CERTIFICATES, SERIES 2007-AR6 is the Plaintiff and NEHEMAN A JALLER A/K/A NEHEMAN ALBERTO JALLER, UNKNOWN TENANT N/K/A JOHN THOMAS and UNKNOWN TENANT IN POSSESSION OF THE SUBJECT PROPERTY are defendants. The Clerk of this Court shall sell to the highest and best bidder for cash electronically at www.sarasota.realforeclose.com at, 9:00 AM on the 25th day of October 2012, the following described property

as set forth in said Final Judgment, to wit:

LOT 7, BLOCK 654, 14TH ADDITION TO PORT CHARLOTTE SUBDIVISION, ACCORDING TO THE PLAT THEREOF, AS RECORDED IN PLAT BOOK 13, AT PAGES 13, 13A THROUGH 13Q, OF THE PUBLIC RECORDS OF SARASOTA COUNTY, FLORIDA

ANY PERSON CLAIMING AN INTEREST IN THE SURPLUS FROM THE SALE, IF ANY, OTHER THAN THE PROPERTY OWNER AS OF THE DATE OF THE LIS PENDENS MUST FILE A CLAIM WITHIN 60 DAYS AFTER THE SALE.

In accordance with the Americans With Disabilities Act, persons needing a reasonable accommodation to participate in this proceeding should contact the Clerk of the Circuit Court no later than seven business days prior to the proceeding at the Sarasota County Courthouse. Telephone 941-861-7425 (Sarasota and Venice) or 1-800-955-8770 via Florida Relay Service.

Dated this 29 day of September, 2012.

By: Nicole J. Saviano, Esq.
Bar Number: 73162

Submitted by:
LAW OFFICES OF
MARSHALL C. WATSON, P.A.
1800 NW 49th Street, Suite 120
Fort Lauderdale, Florida 33309
Telephone: (954) 453-0365
Facsimile: (954) 771-6052
Toll Free: 1-800-441-2438
DESIGNATED PRIMARY E-MAIL
FOR SERVICE PURSUANT TO FLA.
R. JUD. ADMIN 2.516
eservice@marshallwatson.com
09-57090
October 5, 12, 2012 12-3810S

SECOND INSERTION

NOTICE TO CREDITORS
IN THE CIRCUIT COURT FOR
SARASOTA COUNTY, FLORIDA
PROBATE DIVISION
File No. 2012CP003576NC
IN RE: ESTATE OF
RUTH KEPNES
Deceased

The administration of the estate of RUTH KEPNES, deceased, whose date of death was August 10, 2012, is pending in the Circuit Court for SARASOTA County, Florida, Probate Division, the address of which is P.O. Box 3079, Sarasota, Florida 34230. The names and addresses of the personal representative and the personal representative's attorney are set forth below.

All creditors of the decedent and other persons having claims or demands against decedent's estate on whom a copy of this notice is required to be served must file their claims with this court WITHIN THE LATER OF 3 MONTHS AFTER THE TIME OF THE FIRST PUBLICATION OF THIS NOTICE OR 30 DAYS AFTER THE DATE OF SERVICE OF A COPY OF THIS NOTICE ON THEM.

All other creditors of the decedent and other persons having claims or demands against decedent's estate must file their claims with this court WITHIN 3 MONTHS AFTER THE DATE OF THE FIRST PUBLICATION OF THIS NOTICE.

ALL CLAIMS NOT FILED WITHIN THE TIME PERIODS SET FORTH IN SECTION 733.702 OF THE FLORIDA PROBATE CODE WILL BE FOREVER BARRED.

NOTWITHSTANDING THE TIME PERIODS SET FORTH ABOVE, ANY CLAIM FILED TWO (2) YEARS OR MORE AFTER THE DECEDENT'S DATE OF DEATH IS BARRED.

The date of first publication of this notice is October 5, 2012.

Personal Representative:

WAYNE F. SEITL
3665 Bee Ridge Rd., Suite 300
Sarasota, Florida 34233
Attorney for Personal Representative:
JONATHAN T. ANDERSON
Attorney for WAYNE F. SEITL
Florida Bar Number: 188530
WOOD, SEITL & ANDERSON, P.A.
3665 Bee Ridge Road, Suite 300
Sarasota, Florida 34233-1056
Telephone: (941) 954-5772
Fax: (941) 925-9164
October 5, 12, 2012 12-3800S

SECOND INSERTION

NOTICE TO CREDITORS
IN THE CIRCUIT COURT FOR
SARASOTA COUNTY, FLORIDA
PROBATE DIVISION
File No. 2012 CP 003516 NC
IN RE: ESTATE OF
ALAN GIDWITZ, DECEASED.

The administration of the estate of Alan Gidwitz, deceased, whose date of death was August 1, 2012, and whose last four digits of his social security number are 0355, file number 2012 CP 003516 NC is pending in the Circuit Court for Sarasota County, Florida, Probate Division, the address of which is 2000 Main Street, Room 102, Sarasota, Florida 34237. The names and addresses of the personal representative and the personal representative's attorney are set forth below.

All creditors of the decedent and other persons having claims or demands against decedent's estate, on whom a copy of this notice is required to be served, must file their claims of this court WITHIN THE LATER OF 3 MONTHS AFTER THE TIME OF THE FIRST PUBLICATION OF THIS NOTICE OR 30 DAYS AFTER THE DATE OF SERVICE OF A COPY OF THIS NOTICE ON THEM.

All other creditors of the decedent and other persons having claims or demands against decedent's estate must file their claims with this court WITHIN 3 MONTHS AFTER THE DATE OF THE FIRST PUBLICATION OF THIS NOTICE.

ALL CLAIMS NOT FILED WITHIN THE TIME PERIODS SET FORTH IN SECTION 733.702 OF THE FLORIDA PROBATE CODE WILL BE FOREVER BARRED.

NOTWITHSTANDING THE TIME PERIODS SET FORTH ABOVE, ANY CLAIM FILED TWO (2) YEARS OR MORE AFTER THE DECEDENT'S DATE OF DEATH IS BARRED.

The date of first publication of this notice is October 5, 2012.

Personal Representative:

Joyce Gidwitz
2377 Gulf of Mexico Drive 2D2,
Longboat Key, Florida 34228
Attorney for Personal Representative:
Maureen T. Reynolds
Florida Bar No. 0078384
REED SMITH, LLP
10 S. Wacker Dr., Suite 4000
Chicago, Illinois 60606
Telephone: (312) 207-1000
October 5, 12, 2012 12-3798S

SECOND INSERTION

NOTICE TO CREDITORS
IN THE CIRCUIT COURT FOR
SARASOTA COUNTY, FLORIDA
PROBATE DIVISION
File No. 2012 CP 003587 NC
IN RE: ESTATE OF
GRIGORI TKACH
Deceased.

The administration of the estate of GRIGORI TKACH, deceased, whose date of death was July 2, 2012, is pending in the Circuit Court for SARASOTA County, Florida, Probate Division, the address of which is PO Box 3079, Sarasota, FL 34230. The names and addresses of the personal representative and the personal representative's attorney are set forth below.

All creditors of the decedent and other persons having claims or demands against decedent's estate on whom a copy of this notice is required to be served must file their claims with this court WITHIN THE LATER OF 3 MONTHS AFTER THE TIME OF THE FIRST PUBLICATION OF THIS NOTICE OR 30 DAYS AFTER THE DATE OF SERVICE OF A COPY OF THIS NOTICE ON THEM.

All other creditors of the decedent and other persons having claims or demands against decedent's estate must file their claims with this court WITHIN 3 MONTHS AFTER THE DATE OF THE FIRST PUBLICATION OF THIS NOTICE.

ALL CLAIMS NOT FILED WITHIN THE TIME PERIODS SET FORTH IN SECTION 733.702 OF THE FLORIDA PROBATE CODE WILL BE FOREVER BARRED.

NOTWITHSTANDING THE TIME PERIODS SET FORTH ABOVE, ANY CLAIM FILED TWO (2) YEARS OR MORE AFTER THE DECEDENT'S DATE OF DEATH IS BARRED.

The date of first publication of this notice is October 5, 2012.

Personal Representative:

EVGENIA TKACH
5995 Marigold Road
Venice, Florida 34293
Attorney for Personal Representative:
Annette Z.P. Ross
Attorney for EVGENIA TKACH
Florida Bar Number: 0141259
901 Venetia Bay Blvd., Suite 351
Venice, FL 34285
Telephone: (941) 480-1948
Fax: (941) 480-9277
E-Mail: aross80974@aol.com
October 5, 12, 2012 12-3871S

SECOND INSERTION

NOTICE TO CREDITORS
IN THE CIRCUIT COURT FOR
SARASOTA COUNTY, FLORIDA
PROBATE DIVISION
File No.: 2012 CP 003531 NC
IN RE: ESTATE OF
ANDREA LEE RODY,
Deceased.

The administration of the estate of ANDREA LEE RODY, deceased, whose date of death was August 6, 2012; File Number 2012CP003531NC, is pending in the Circuit Court for Sarasota County, Florida, Probate Division, the address of which is 2000 Main Street, Sarasota, FL 34237. The names and addresses of the personal representative and the personal representative's attorney are set forth below.

All creditors of the decedent and other persons having claims or demands against decedent's estate, on whom a copy of this notice is required to be served, must file their claims with this court WITHIN THE LATER OF 3 MONTHS AFTER THE TIME OF THE FIRST PUBLICATION OF THIS NOTICE OR 30 DAYS AFTER THE DATE OF SERVICE OF A COPY OF THIS NOTICE ON THEM.

All other creditors of the decedent and other persons having claims or demands against decedent's estate, must file their claims with this court WITHIN 3 MONTHS AFTER THE DATE OF THE FIRST PUBLICATION OF THIS NOTICE.

ALL CLAIMS NOT FILED WITHIN THE TIME PERIODS SET FORTH IN SECTION 733.702 OF THE FLORIDA PROBATE CODE WILL BE FOREVER BARRED.

NOTWITHSTANDING THE TIME PERIOD SET FORTH ABOVE, ANY CLAIM FILED TWO (2) YEARS OR MORE AFTER THE DECEDENT'S DATE OF DEATH IS BARRED.

The date of first publication of this notice is: October 5, 2012.

SHIRLEY LEE RODY

Personal Representative
362 Tahitian Drive
Ellenton, FL 34222
Robert D. Hines
Attorney for Personal Representative
Email: rhines@hnh-law.com
Florida Bar No. 0413550
HINES NORMAN HINES, P.L.
1312 W. Fletcher Avenue
Suite B
Tampa, FL 33612
Telephone: 813-265-0100
October 5, 12, 2012 12-3795S

SECOND INSERTION

NOTICE OF FORECLOSURE SALE
IN THE CIRCUIT COURT OF THE
TWELFTH JUDICIAL CIRCUIT IN
AND FOR SARASOTA COUNTY
GENERAL JURISDICTION
DIVISION
CASE NO. 2009 CA 006805 NC
JPMORGAN CHASE BANK, NA,
Plaintiff, vs.
JOSHUA E BEACHY, et al.,
Defendants.

NOTICE IS HEREBY GIVEN pursuant to a Summary Final Judgment of Foreclosure filed September 24th, 2012 entered in Civil Case No. 2009 CA 006805 NC of the Circuit Court of the TWELFTH Judicial Circuit in and for Sarasota County, Nokomis, Florida, the Clerk of Court will sell to the highest and best bidder for cash electronically at www.sarasota.realestate.com in accordance with Chapter 45, Florida Statutes on the 22nd day of January, 2013 at 09:00 AM on the following described property as set forth in said Summary Final Judgment, to-wit:

LOT 4, LAUREL LANDINGS ESTATES, ACCORDING TO THE PLAT THEREOF AS RECORDED IN PLAT BOOK 36, PAGE(S) 23 AND 23A THROUGH 23E, PUBLIC RECORDS OF SARASOTA COUNTY, FLORIDA.

Any person claiming an interest in the surplus from the sale, if any, other than the property owner as of the date of the lis pendens, must file a claim within 60 days after the sale.

In accordance with the Americans With Disabilities Act, persons needing a reasonable accommodation to participate in this proceeding should contact the Clerk of the Circuit Court no later than seven business days prior to the proceeding at the Sarasota County Courthouse. Telephone 941-861-7425 (Sarasota and Venice) or 1-800-955-8770 via Florida Relay Service.

Lindsey Davis, Esq.
McCALLA RAYMER, LLC
Attorney For Plaintiff
225 East Robinson St. Suite 660
Orlando, FL 32801
Phone: (407) 674-1850
Fax: (321) 248-0420
Email:
MRService@mccallarayer.com
Fla. Bar No.: 65711
727164
11-02784-3
October 5, 12, 2012 12-3774S

SECOND INSERTION

NOTICE OF SALE
IN THE CIRCUIT CIVIL COURT OF
THE TWELFTH JUDICIAL
CIRCUIT OF FLORIDA, IN AND
FOR SARASOTA COUNTY
CIVIL DIVISION
Case No. 58-2011-CA-007834 NC
Division C
MIDFIRST BANK
Plaintiff, vs.
VICTOR JOHNSON, ZENA Y.
JOHNSON, AND UNKNOWN
TENANTS/OWNERS,
Defendants.

Notice is hereby given, pursuant to Final Judgment of Foreclosure for Plaintiff entered in this cause on September 24, 2012, in the Circuit Court of Sarasota County, Florida, The Clerk of the Court will sell the property situated in Sarasota County, Florida described as: LOT 5, BLOCK "C", NEW-TOWN HEIGHTS, ACCORDING TO THE PLAT THEREOF, RECORDED IN PLAT BOOK 1, PAGE 108 OF THE PUBLIC RECORDS OF SARASOTA COUNTY, FLORIDA.

and commonly known as: 3026 GILLESPIE AVE, SARASOTA, FL 34234; including the building, appurtenances, and fixtures located therein, at public sale, to the highest and best bidder, for cash, Sales are held online at: https://www.sarasota.realestate.com, on November 21, 2012 at 9:00 A.M..

Any persons claiming an interest in the surplus from the sale, if any, other than the property owner as of the date of the lis pendens must file a claim within 60 days after the sale.

In accordance with the Americans With Disabilities Act, persons needing a reasonable accommodation to participate in this proceeding should contact the Clerk of the Circuit Court no later than seven business days prior to the proceeding at the Sarasota County Courthouse. Telephone 941-861-7425 (Sarasota and Venice) or 1-800-955-8770 via Florida Relay Service.
Dated this 24th day of September, 2012.

By: Karen E. Rushing
Frances Grace Cooper, Esquire
Attorney for Plaintiff
Edward B. Pritchard
(813) 229-0900 x1309
KASS SHULER, P.A.
P.O. Box 800
Tampa, FL 33601-0800
October 5, 12, 2012 12-3771S

SECOND INSERTION

NOTICE TO CREDITORS
IN THE CIRCUIT COURT FOR
SARASOTA COUNTY,
FLORIDA
PROBATE DIVISION
File No. 2012 CP 003626 NC
IN RE: ESTATE OF
RUTH SMITH,
Deceased.

The administration of the estate of RUTH SMITH, deceased, whose date of death was August 13, 2012; File Number 2012 CP 003626 NC, is pending in the Circuit Court for Sarasota County, Florida, Probate Division, the address of which is P. O. Box 3079, Sarasota, FL 34230. The names and addresses of the personal representative and the personal representative's attorney are set forth below.

All creditors of the decedent and other persons having claims or demands against decedent's estate, on whom a copy of this notice is required to be served, must file their claims with this court WITHIN THE LATER OF 3 MONTHS AFTER THE TIME OF THE FIRST PUBLICATION OF THIS NOTICE OR 30 DAYS AFTER THE DATE OF SERVICE OF A COPY OF THIS NOTICE ON THEM.

All other creditors of the decedent and other persons having claims or demands against decedent's estate must file their claims with this court WITHIN 3 MONTHS AFTER THE DATE OF THE FIRST PUBLICATION OF THIS NOTICE.

ALL CLAIMS NOT FILED WITHIN THE TIME PERIODS SET FORTH IN SECTION 733.702 OF THE FLORIDA PROBATE CODE WILL BE FOREVER BARRED.

NOTWITHSTANDING THE TIME PERIOD SET FORTH ABOVE, ANY CLAIM FILED TWO (2) YEARS OR MORE AFTER THE DECEDENT'S DATE OF DEATH IS BARRED.

The date of first publication of this notice is: October 5, 2012.

Signed on 9/27/12.

THOMAS E. SMITH
Personal Representative
96 Clearview Drive
Hopkins, SC 29061
Charla M. Burchett
Attorney for Personal Representative
Email: cmb@burchettlaw.com ;
court@burchettlaw.com
Florida Bar No. 0813230
CHARLA M. BURCHETT, PLC
766 Hudson Avenue, Suite C
Sarasota, FL 34230-3079
Telephone: (941) 951-1866
Fax: (941) 951-9955
October 5, 12, 2012 12-3794S

SECOND INSERTION

NOTICE TO CREDITORS
IN THE CIRCUIT COURT FOR
SARASOTA COUNTY, FLORIDA
PROBATE DIVISION
File No. 2012 CP 003663 NC
IN RE: ESTATE OF
BERYL E. TATRO
Deceased.

The administration of the estate of BERYL E. TATRO, deceased, whose date of death was September 16, 2012, is pending in the Circuit Court for SARASOTA County, Florida, Probate Division, the address of which is PO Box 3079, Sarasota, Florida 34230. The names and addresses of the personal representatives and the personal representative's attorney are set forth below.

All creditors of the decedent and other persons having claims or demands against decedent's estate on whom a copy of this notice is required to be served must file their claims with this court WITHIN THE LATER OF 3 MONTHS AFTER THE TIME OF THE FIRST PUBLICATION OF THIS NOTICE OR 30 DAYS AFTER THE DATE OF SERVICE OF A COPY OF THIS NOTICE ON THEM.

All other creditors of the decedent and other persons having claims or demands against decedent's estate, must file their claims with this court WITHIN 3 MONTHS AFTER THE DATE OF THE FIRST PUBLICATION OF THIS NOTICE.

ALL CLAIMS NOT FILED WITHIN THE TIME PERIODS SET FORTH IN SECTION 733.702 OF THE FLORIDA PROBATE CODE WILL BE FOREVER BARRED.

NOTWITHSTANDING THE TIME PERIOD SET FORTH ABOVE, ANY CLAIM FILED TWO (2) YEARS OR MORE AFTER THE DECEDENT'S DATE OF DEATH IS BARRED.

The date of first publication of this notice is October 5, 2012.

Personal Representatives:

Charles L. Hanscomb
203 Colonade Circle
Naples, Florida 34103
Attorney for Personal Representatives:
John A. Moran
Attorney for Charles L. Hanscomb
Florida Bar Number: 0718335
DUNLAP & MORAN PA
Post Office Box 3948
Sarasota, FL 34230
Telephone: (941) 366-0115
Fax: (941) 365-4660
E-Mail: jrieker@dunlapmoran.com
Secondary E-Mail:
jmassistant@dunlapmoran.com
October 5, 12, 2012 12-3837S

SECOND INSERTION

NOTICE TO CREDITORS
IN THE CIRCUIT COURT FOR
SARASOTA COUNTY, FLORIDA
PROBATE DIVISION
File No. 2012-CP-003460 NC
IN RE: ESTATE OF
MARIA DOLORES LOPEZ a/k/a
DOLORES MARIA LOPEZ,
Deceased.

The administration of the estate of MARIA DOLORES LOPEZ a/k/a DOLORES MARIA LOPEZ, deceased, whose date of death was August 4, 2012; File Number 2012-CP-003460 NC, is pending in the Circuit Court for Sarasota County, Florida, Probate Division, the address of which is PO Box 3079, Sarasota, FL 34230. The names and addresses of the personal representative and the personal representative's attorney are set forth below.

All creditors of the decedent and other persons having claims or demands against decedent's estate on whom a copy of this notice is required to be served must file their claims with this court WITHIN THE LATER OF 3 MONTHS AFTER THE TIME OF THE FIRST PUBLICATION OF THIS NOTICE OR 30 DAYS AFTER THE DATE OF SERVICE OF A COPY OF THIS NOTICE ON THEM.

All other creditors of the decedent and other persons having claims or demands against decedent's estate must file their claims with this court WITHIN 3 MONTHS AFTER THE DATE OF THE FIRST PUBLICATION OF THIS NOTICE.

ALL CLAIMS NOT FILED WITHIN THE TIME PERIODS SET FORTH IN SECTION 733.702 OF THE FLORIDA PROBATE CODE WILL BE FOREVER BARRED.

NOTWITHSTANDING THE TIME PERIOD SET FORTH ABOVE, ANY CLAIM FILED TWO (2) YEARS OR MORE AFTER THE DECEDENT'S DATE OF DEATH IS BARRED.

The date of first publication of this notice is October 5, 2012.

RICHARD A. LOPEZ

Personal Representative
9 Columbia Place
Brooklyn, NY 11201
Elizabeth C. Marshall
Attorney for Personal Representative
Email: emarshall@williamsparker.com
Florida Bar No. 0440884
WILLIAMS PARKER HARRISON
DIETZ & GETZEN
200 S. Orange Ave.
Sarasota, FL 34236
Telephone: 941-366-4800
October 5, 12, 2012 12-3872S

SECOND INSERTION

NOTICE TO CREDITORS
IN THE CIRCUIT COURT FOR
SARASOTA COUNTY, FLORIDA
PROBATE DIVISION
File No. 2012 CP 3246 NC
Twelfth Judicial Circuit
IN RE: ESTATE OF
DIANE H. FRITSCHLE
Deceased.

The administration of the estate of DIANE H. FRITSCHLE, deceased, whose date of death was June 30, 2012, and whose social security number was xxx-xx-6119, is pending in the Circuit Court for Sarasota County, Florida, Probate Division, the address of which is 2002 Ringling Blvd., Sarasota, Florida 34237. The names and addresses of the personal representative and the personal representative's attorney are set forth below.

All creditors of the decedent and other persons having claims or demands against decedent's estate on whom a copy of this notice is required to be served must file their claims with this court WITHIN THE LATER OF 3 MONTHS AFTER THE TIME OF THE FIRST PUBLICATION OF THIS NOTICE OR 30 DAYS AFTER THE DATE OF SERVICE OF A COPY OF THIS NOTICE ON THEM.

All other creditors of the decedent and other persons having claims or demands against decedent's estate must file their claims with this court WITHIN 3 MONTHS AFTER THE DATE OF THE FIRST PUBLICATION OF THIS NOTICE.

ALL CLAIMS NOT FILED WITHIN THE TIME PERIODS SET FORTH IN SECTION 733.702 OF THE FLORIDA PROBATE CODE WILL BE FOREVER BARRED.

NOTWITHSTANDING THE TIME PERIOD SET FORTH ABOVE, ANY CLAIM FILED TWO (2) YEARS OR MORE AFTER THE DECEDENT'S DATE OF DEATH IS BARRED.

The date of first publication of this notice is: October 5, 2012.

Personal Representative:

Amy Coughlin
706 Oakwood Avenue
Dayton, Ohio 45419
Attorney for Personal Representative:
John M. Compton
E-Mail Address:
jcompton@nhslaw.com
Florida Bar No. 0128058
NORTON, HAMMERSLEY,
LOPEZ & SKOKOS, P.A.
1819 Main Street, Suite 610
Sarasota, Florida 34236
Telephone: (941) 954-4691
October 5, 12, 2012 12-3841S

SECOND INSERTION

NOTICE TO CREDITORS
IN THE CIRCUIT COURT FOR
SARASOTA COUNTY, FLORIDA
PROBATE DIVISION
File No. 2012-CP 003498 NC
Division Sarasota
IN RE: ESTATE OF
MARVIN P. KANE
Deceased.

The administration of the estate of MARVIN P. KANE, deceased, whose date of death was August 28, 2012; File Number 2012-CP 003498 NC, is pending in the Circuit Court for Sarasota County, Florida, Probate Division, the address of which is P.O. Box 3079, Sarasota, FL 34230-3079. The names and addresses of the personal representative and the personal representative's attorney are set forth below.

All creditors of the decedent and other persons having claims or demands against decedent's estate, on whom a copy of this notice is required to be served must file their claims with this court WITHIN THE LATER OF 3 MONTHS AFTER THE TIME OF THE FIRST PUBLICATION OF THIS NOTICE OR 30 DAYS AFTER THE DATE OF SERVICE OF A COPY OF THIS NOTICE ON THEM.

All other creditors of the decedent and other persons having claims or demands against decedent's estate must file their claims with this court WITHIN 3 MONTHS AFTER THE DATE OF THE FIRST PUBLICATION OF THIS NOTICE.

ALL CLAIMS NOT FILED WITHIN THE TIME PERIODS SET FORTH IN SECTION 733.702 OF THE FLORIDA PROBATE CODE WILL BE FOREVER BARRED.

NOTWITHSTANDING THE TIME PERIOD SET FORTH ABOVE, ANY CLAIM FILED TWO (2) YEARS OR MORE AFTER THE DECEDENT'S DATE OF DEATH IS BARRED.

The date of first publication of this notice is: October 5, 2012.

DAVID G. KANE

Personal Representative
204 Birch Rd.
Peachtree City GA 30269
STEVEN J. KANE
Personal Representative
14 West 14th St., Apt 9-A
New York NY 10011
H. GREG LEE
Attorney for Personal Representatives
Email: hglee@hgreglee.com
Florida Bar No. 0351301
H. GREG LEE, P.A.
2014 Fourth St.
Sarasota FL 34237
Telephone: (941) 954-0067
Facsimile: (941) 365-1492
October 5, 12, 2012 12-3839S

SECOND INSERTION

NOTICE TO CREDITORS
IN THE CIRCUIT COURT
IN AND FOR
SARASOTA COUNTY, FLORIDA
PROBATE DIVISION
File No. 2012-CP-003381-NC
IN RE: The Estate of:
PAMELA ZOE ANDERSON,
Deceased.

The administration of the estate of Pamela Zoe Anderson, deceased, whose date of death was August 21, 2012 is pending in the Circuit Court for Sarasota County, Florida, Probate Division, File Number 2012-CP-003381-NC, the address of which is Post Office Box 3079, Sarasota, Florida 34230. The names and addresses of the personal representative and the personal representative's attorney are set forth below.

All creditors of the decedent and other persons who have claims or demands against decedent's estate, including unmaturred, contingent, or unliquidated claims, and who have been served a copy of this notice, must file their claims with this court WITHIN THE LATER OF THREE (3) MONTHS AFTER THE DATE OF THE FIRST PUBLICATION OF THIS NOTICE OR THIRTY (30) DAYS AFTER THE DATE OF SERVICE OF A COPY OF THIS NOTICE ON THEM.

All other creditors of the decedent and other persons who have claims or demands against decedent's estate, including unmaturred, contingent, or unliquidated claims, must file their claims with this court WITHIN THREE (3) MONTHS AFTER THE DATE OF THE FIRST PUBLICATION OF THIS NOTICE.

ALL CLAIMS NOT SO FILED WILL BE FOREVER BARRED.

NOTWITHSTANDING THE TIME PERIODS SET FORTH ABOVE, ANY CLAIM FILED TWO (2) YEARS OR MORE AFTER THE DECEDENT'S DATE OF DEATH IS BARRED.

THE DATE OF FIRST PUBLICATION OF THIS NOTICE IS: OCTOBER 5, 2012.

Personal Representatives:
George R. McLain
1800 Second Street, Suite 735
Sarasota, FL 34236
Attorney for Personal Representative:
George R. McLain
Florida Bar No. 115510
METCALFE & MCCLAIN, P.A.
1800 Second Street, #735
Sarasota, Florida 34236
(941) 365-4174
george.mclain@metcalfeclain.com
terri.nickel@metcalfeclain.com
October 5, 12, 2012 12-3797S

SECOND INSERTION

NOTICE OF FORECLOSURE SALE IN THE CIRCUIT COURT OF THE TWELFTH JUDICIAL CIRCUIT, IN AND FOR SARASOTA COUNTY, FLORIDA

CIVIL DIVISION
CASE NO.: 2010-CA-007888-NC
JPMORGAN CHASE BANK, NATIONAL ASSOCIATION
Plaintiff, vs.
SANDRA M. CAMPBELL, et al
Defendants.

NOTICE IS HEREBY GIVEN pursuant to a Summary Final Judgment of foreclosure dated September 18, 2012, and entered in Case No. 2010-CA-007888-NC of the Circuit Court of the TWELFTH Judicial Circuit in and for SARASOTA COUNTY, Florida, wherein JPMORGAN CHASE BANK, NATIONAL ASSOCIATION, is Plaintiff, and SANDRA M. CAMPBELL, et al are Defendants, the clerk will sell to the highest and best bidder for cash, beginning at 09:00 AM at www.sarasota.realforeclose.com, in accordance with Chapter 45, Florida Statutes, on the 23 day of October, 2012, the following described property as set forth in said Summary Final Judgment, to wit:
Unit 135, Building 1, Sarasota Palms, a Condominium, according to the Declaration of Condominium, as recorded in

Official Records Instrument #2004247151, and as amended, and as per plat thereof, as recorded in Condominium Book 37, Page 26, 26A, as amended, of the Public Records of Sarasota County, Florida.

Any person claiming an interest in the surplus funds from the sale, if any, other than the property owner as of the date of the lis pendens must file a claim within 60 days after the sale.

In accordance with the Americans With Disabilities Act, persons needing a reasonable accommodation to participate in this proceeding should contact the Clerk of the Circuit Court no later than seven business days prior to the proceeding at the Sarasota County Courthouse. Telephone 941-861-7425 (Sarasota and Venice) or 1-800-955-8770 via Florida Relay Service.
Dated this 24th day of September, 2012.

By: Drew T. Melville, Esq.,
Florida Bar No. 34986
Attorney for Plaintiff

PHELAN HALLINAN PLC
2727 West Cypress Creek Road
Ft. Lauderdale, FL 33309
T: 954-462-7000
F: 954-462-7001
PH #: 20776
October 5, 12, 2012 12-3805S

SECOND INSERTION

NOTICE OF FORECLOSURE SALE IN THE CIRCUIT COURT OF THE 12TH JUDICIAL CIRCUIT, IN AND FOR SARASOTA COUNTY, FLORIDA

CIVIL DIVISION:
CASE NO.: 58-2010-CA-002550 NC
DEUTSCHE BANK TRUST COMPANY AMERICAS AS TRUSTEE,
Plaintiff, vs.
CHRISTIE A. HAYS; GARY P. HAYS; UNKNOWN TENANT(S); IN POSSESSION OF THE SUBJECT PROPERTY,
Defendant(s).

NOTICE IS HEREBY GIVEN pursuant to Final Judgment of Foreclosure dated the 18th day of July, 2012, and entered in Case No. 58-2010-CA-002550 NC, of the Circuit Court of the 12TH Judicial Circuit in and for Sarasota County, Florida, wherein DEUTSCHE BANK TRUST COMPANY AMERICAS AS TRUSTEE is the Plaintiff and CHRISTIE A. HAYS, GARY P. HAYS and UNKNOWN TENANT(S); IN POSSESSION OF THE SUBJECT PROPERTY are defendants. The Clerk of this Court shall sell to the highest and best bidder for cash electronically at www.sarasota.realforeclose.com at 9:00 AM on the 26th day of October, 2012, the following described property as set forth in said Final Judgment, to wit:

LOT 24, BLOCK 1584, THIRTY-SECOND ADDITION TO PORT CHARLOTTE SUBDIVISION, ACCORDING TO THE MAP OR PLAT THEREOF RECORDED IN PLAT BOOK 15, PAGES 16, 16A THROUGH 16L, OF THE PUBLIC RECORDS OF SARASOTA COUNTY, FLORIDA.

ANY PERSON CLAIMING AN INTEREST IN THE SURPLUS FROM THE SALE, IF ANY, OTHER THAN THE PROPERTY OWNER AS OF THE DATE OF THE LIS PENDENS MUST FILE A CLAIM WITHIN 60 DAYS AFTER THE SALE.

In accordance with the Americans With Disabilities Act, persons needing a reasonable accommodation to participate in this proceeding should contact the Clerk of the Circuit Court no later than seven business days prior to the proceeding at the Sarasota County Courthouse. Telephone 941-861-7425 (Sarasota and Venice) or 1-800-955-8770 via Florida Relay Service.
Dated this 01 day of October, 2012.

By: Michelle Zelina, Esq.
Bar Number: 85613

Submitted by:
LAW OFFICES OF
MARSHALL C. WATSON, P.A.
1800 NW 49th Street, Suite 120
Fort Lauderdale, Florida 33309
Telephone: (954) 453-0365
Facsimile: (954) 771-6052
Toll Free: 1-800-441-2438
DESIGNATED PRIMARY E-MAIL FOR SERVICE PURSUANT TO FLA. R. JUD. ADMIN 2.516
eservice@marshallwatson.com
09-57407
October 5, 12, 2012 12-3830S

SECOND INSERTION

RE-NOTICE OF FORECLOSURE SALE IN THE CIRCUIT COURT OF THE 12TH JUDICIAL CIRCUIT, IN AND FOR SARASOTA COUNTY, FLORIDA

CIVIL DIVISION:
CASE NO.: 2009 CA 008114 NC
BANK OF AMERICA NA,
Plaintiff, vs.
HOANG VAN; SAN PALERMO AT SARASOTA HOMEOWNERS ASSOCIATION, INC; THUY THAI; UNKNOWN TENANT(S); IN POSSESSION OF THE SUBJECT PROPERTY,
Defendant(s).

NOTICE IS HEREBY GIVEN pursuant to an Order Resetting Foreclosure Sale dated the 20th day of September, 2012, and entered in Case No. 2009 CA 008114 NC, of the Circuit Court of the 12TH Judicial Circuit in and for Sarasota County, Florida, wherein BANK OF AMERICA NA is the Plaintiff and HOANG VAN; SAN PALERMO AT SARASOTA HOMEOWNERS ASSOCIATION, INC; THUY THAI; UNKNOWN TENANT N/K/A BRIAN WALTERS; UNKNOWN TENANT(S); IN POSSESSION OF THE SUBJECT PROPERTY are defendants. The Clerk of this Court shall sell to the highest and best bidder for cash electronically at www.sarasota.realforeclose.com at 9:00 AM on the 24th day of October, 2012, the following described property as set forth in said Final Judgment, to wit:

LOT 81, SAN PALERMO, ACCORDING TO THE PLAT THEREOF, RECORDED IN PLAT BOOK 45, PAGES 9 THROUGH 9D, INCLUSIVE, OF THE PUBLIC RECORDS OF SARASOTA COUNTY, FLORIDA.

ANY PERSON CLAIMING AN INTEREST IN THE SURPLUS FROM THE SALE, IF ANY, OTHER THAN THE PROPERTY OWNER AS OF THE DATE OF THE LIS PENDENS MUST FILE A CLAIM WITHIN 60 DAYS AFTER THE SALE.

In accordance with the Americans With Disabilities Act, persons needing a reasonable accommodation to participate in this proceeding should contact the Clerk of the Circuit Court no later than seven business days prior to the proceeding at the Sarasota County Courthouse. Telephone 941-861-7425 (Sarasota and Venice) or 1-800-955-8770 via Florida Relay Service.
Dated this 01 day of October, 2012.

By: Wendy Manswell, Esq.
Bar Number: 12027

Submitted by:
LAW OFFICES OF
MARSHALL C. WATSON, P.A.
1800 NW 49th Street, Suite 120
Fort Lauderdale, Florida 33309
Telephone: (954) 453-0365
Facsimile: (954) 771-6052
Toll Free: 1-800-441-2438
DESIGNATED PRIMARY E-MAIL FOR SERVICE PURSUANT TO FLA. R. JUD. ADMIN 2.516
eservice@marshallwatson.com
09-26988
October 5, 12, 2012 12-3825S

SECOND INSERTION

NOTICE OF SALE IN THE CIRCUIT COURT OF THE TWELFTH JUDICIAL CIRCUIT IN AND FOR SARASOTA COUNTY, FLORIDA

CASE NO. 2010 CA 011345 NC
CITIMORTGAGE, INC.,
Plaintiff, v.
SCOTT D. PALMER et al.,
Defendants.

NOTICE IS HEREBY GIVEN that, pursuant to the Uniform Final Judgment of Mortgage Foreclosure entered on September 24, 2012 in the above-captioned action, the following property situated in Sarasota County, Florida, described as:

LOT 4, BLOCK B, OF THE REVISED PLAT OF POINSETTIA PARK, AS PER PLAT THEREOF RECORDED IN PLAT BOOK 1, PAGE 180, OF THE PUBLIC RECORDS OF SARASOTA COUNTY, FLORIDA.

Shall be sold by the Clerk of Court on the 31st day of October, 2012 on-line at 9:00 a.m. (Eastern Time) at www.sarasota.realforeclose.com to the highest bidder, for cash, after giving notice as required by section 45.031, Florida Statutes.

Any person claiming an interest in the surplus from the sale, if any, other than the owner as of the date of the Lis Pendens must file a claim within 60 days after the sale. The court, in its discretion, may enlarge the time of the sale. Notice of the changed time of sale shall be published as provided herein.

In accordance with the Americans With Disabilities Act, persons needing a reasonable accommodation to participate in this proceeding should contact the Clerk of the Circuit Court no later than seven business days prior to the proceeding at the Sarasota County Courthouse. Telephone 941-861-7425 (Sarasota and Venice) or 1-800-955-8770 via Florida Relay Service.

Suzanne Delaney
THORNE & STOREY, P.A.
212 Pasadena Place
Orlando, FL 32803
(407) 488-1222
Attorneys for Plaintiff
Fl. Bar No.: 0957941
October 5, 12, 2012 12-3778S

SECOND INSERTION

NOTICE TO CREDITORS (summary administration) IN THE CIRCUIT COURT FOR SARASOTA COUNTY, FLORIDA PROBATE DIVISION
File No. 2012 CP 3445
IN RE: ESTATE OF GERALDINE K. WORLEY
Deceased.

TO ALL PERSONS HAVING CLAIMS OR DEMANDS AGAINST THE ABOVE ESTATE:

You are hereby notified that an Order of Summary Administration has been entered in the estate of Geraldine K. Worley, deceased, File Number 2012 CP 3445, by the Circuit Court for Sarasota County, Florida, Probate Division, the address of which is 2000 Main St., PO Box 3079 Sarasota, FL 34230; that the decedent's date of death was June 13th, 2012; that the total value of the estate is \$10,850.00 and that the names and addresses of those to whom it has been assigned by such order are:

Name Address
Joanna Pellegrini, Suc Trustee of James L. Worley, Jr. and Geraldine K. Worley Trust dated 5/28/03

7063 Whisper Creek Dr.
Wentzville, MO 63385
ALL INTERESTED PERSONS ARE NOTIFIED THAT:

All creditors of the estate of the decedent and persons having claims or demands against the estate of the decedent other than those for whom provision for full payment was made in the Order of Summary Administration must file their claims with this court WITHIN THE TIME PERIODS SET FORTH IN SECTION 733.702 OF THE FLORIDA PROBATE CODE. ALL CLAIMS AND DEMANDS NOT SO FILED WILL BE FOREVER BARRED. NOTWITHSTANDING ANY OTHER APPLICABLE TIME PERIOD, ANY CLAIM FILED TWO (2) YEARS OR MORE AFTER THE DECEDENT'S DATE OF DEATH IS BARRED.

The date of first publication of this Notice is October 5, 2012.

Personal Giving Notice:
Joanna Pellegrini
7063 Whisper Creek Dr.
Wentzville, MO 63385
KANETSKY, MOORE & DeBOER P.A.
ATTORNEYS AT LAW
Attorneys for Person Giving Notice
227 S. NOKOMIS AVE.
P.O. BOX 1767
VENICE, FL 34284-1767
Telephone: (941) 485-1571
By: Erik R. Liberman, Esq.
Florida Bar No. 393053
E-Mail Address: ERL@KMDPA.COM
October 5, 12, 2012 12-3796S

SECOND INSERTION

NOTICE OF FORECLOSURE SALE IN THE CIRCUIT COURT OF THE TWELFTH JUDICIAL CIRCUIT, IN AND FOR SARASOTA COUNTY, FLORIDA

CIRCUIT CIVIL DIVISION
Case No.: 2010-CA-010679 NC
THE BANK OF NEW YORK MELLON, AS TRUSTEE FOR CITI HOME EQUITY LOAN TRUST 2002-1;
Plaintiff, vs.
BETTIE BALLARD, et al.,
Defendants.

NOTICE IS HEREBY GIVEN pursuant to an Order or Final Judgment entered in Case No. 2010-CA-010679 NC of the Circuit Court of the TWELFTH Judicial Circuit in and for SARASOTA County, Florida, wherein, THE BANK OF NEW YORK MELLON, AS TRUSTEE FOR CITI HOME EQUITY LOAN TRUST 2002-1, Plaintiff, and, BETTIE BALLARD, et al., are Defendants, Clerk of the Court will sell to the highest bidder for cash at www.sarasota.realforeclosure.com at the hour of 9:00 AM on the 22nd day of January 2013, the following described property:

LOT 10, BLOCK 4, EASTWOOD OAKS SUBDIVISION, UNIT 4, AS PER PLAT THEREOF, AS RECORDED IN PLAT BOOK 12 AT PAGE 25 & 25A, OF THE PUBLIC RECORDS OF SARASOTA COUNTY, FLORIDA.

Any person claiming an interest in the surplus from the sale, if any, other than the property owner as of the date of the Lis Pendens must file a claim within 60 days after the sale.

In accordance with the Americans With Disabilities Act, persons needing a reasonable accommodation to participate in this proceeding should contact the Clerk of the Circuit Court no later than seven business days prior to the proceeding at the Sarasota County Courthouse. Telephone 941-861-7425 (Sarasota and Venice) or 1-800-955-8770 via Florida Relay Service.
DATED this 26 day of September, 2012.

By: Sarah M. Barbaccia
FBN 30043

MORALES LAW GROUP
14750 NW 77th Ct., Ste 303
Miami Lakes, FL 33016
MLG # 11-000291-1
October 5, 12, 2012 12-3775S

SECOND INSERTION

NOTICE OF FORECLOSURE SALE IN THE CIRCUIT COURT OF THE 12TH JUDICIAL CIRCUIT, IN AND FOR SARASOTA COUNTY, FLORIDA

CIVIL DIVISION:
CASE NO.: 2011 CA 004966 NC
BAC HOME LOANS SERVICING, LP FKA COUNTRYWIDE HOME LOANS SERVICING LP,
Plaintiff, vs.
DEREK COUGHLIN; UNKNOWN SPOUSE OF DEREK COUGHLIN;
KIRSTEN COUGHLIN F/K/A
KIRSTEN SPONSELLER;
UNKNOWN TENANT;
IN POSSESSION OF THE SUBJECT PROPERTY,
Defendant(s).

NOTICE IS HEREBY GIVEN pursuant to Final Judgment of Foreclosure dated the 18th day of September, 2012, and entered in Case No. 2011 CA 004966 NC, of the Circuit Court of the 12TH Judicial Circuit in and for Sarasota County, Florida, wherein BAC HOME LOANS SERVICING, LP FKA COUNTRYWIDE HOME LOANS SERVICING LP is the Plaintiff and DEREK COUGHLIN, UNKNOWN SPOUSE OF DEREK COUGHLIN, KIRSTEN COUGHLIN FKA KIRSTEN SPONSELLER and UNKNOWN TENANT(S) NKA DANNY COPPOLO IN POSSESSION OF THE SUBJECT PROPERTY are defendants. The Clerk of this Court shall sell to the highest and best bidder for cash electronically at www.sarasota.realforeclose.com at 9:00 AM on the 26th day of October, 2012, the following described property as set forth in said Final Judgment, to

wit:
LOT 16, EUCLID SUBDIVISION, ACCORDING TO THE PLAT THEREOF, AS RECORDED IN PLAT BOOK 9, PAGE 42, OF THE PUBLIC RECORDS OF SARASOTA COUNTY, FLORIDA.

ANY PERSON CLAIMING AN INTEREST IN THE SURPLUS FROM THE SALE, IF ANY, OTHER THAN THE PROPERTY OWNER AS OF THE DATE OF THE LIS PENDENS MUST FILE A CLAIM WITHIN 60 DAYS AFTER THE SALE.

In accordance with the Americans With Disabilities Act, persons needing a reasonable accommodation to participate in this proceeding should contact the Clerk of the Circuit Court no later than seven business days prior to the proceeding at the Sarasota County Courthouse. Telephone 941-861-7425 (Sarasota and Venice) or 1-800-955-8770 via Florida Relay Service.
Dated this 01 day of October, 2012.

By: Wendy Manswell, Esq.
Bar Number: 12027

Submitted by:
LAW OFFICES OF
MARSHALL C. WATSON, P.A.
1800 NW 49th Street, Suite 120
Fort Lauderdale, Florida 33309
Telephone: (954) 453-0365
Facsimile: (954) 771-6052
Toll Free: 1-800-441-2438
DESIGNATED PRIMARY E-MAIL FOR SERVICE PURSUANT TO FLA. R. JUD. ADMIN 2.516
eservice@marshallwatson.com
09-57407
October 5, 12, 2012 12-3823S

SECOND INSERTION

NOTICE OF FORECLOSURE SALE IN THE CIRCUIT COURT OF THE 12TH JUDICIAL CIRCUIT, IN AND FOR SARASOTA COUNTY, FLORIDA

CIVIL DIVISION:
CASE NO.: 58-2009-CA-009521 NC
BAC HOME LOANS SERVICING, L.P. F/K/A COUNTRYWIDE HOME LOANS SERVICING, L.P.,
Plaintiff, vs.
RICHARD A. LADNY A/K/A RICHARD LADNY; BANK OF AMERICA, N.A. F/K/A COUNTRYWIDE BANK, N.A.; UNKNOWN SPOUSE OF RICHARD A. LADNY A/K/A RICHARD LADNY; UNKNOWN TENANT(S); IN POSSESSION OF THE SUBJECT PROPERTY,
Defendant(s).

NOTICE IS HEREBY GIVEN pursuant to Final Judgment of Foreclosure dated the 18th day of September, 2012, and entered in Case No. 58-2009-CA-009521 NC, of the Circuit Court of the 12TH Judicial Circuit in and for Sarasota County, Florida, wherein BAC HOME LOANS SERVICING, L.P. F/K/A COUNTRYWIDE HOME LOANS SERVICING, L.P. is the Plaintiff and RICHARD A. LADNY A/K/A RICHARD LADNY; BANK OF AMERICA, N.A. F/K/A COUNTRYWIDE BANK, N.A.; UNKNOWN TENANT N/K/A MAGGIE SANCHEZ; UNKNOWN TENANT(S); IN POSSESSION OF THE SUBJECT PROPERTY are defendants. The Clerk of this Court shall sell to the highest and best bidder for cash electronically at www.sarasota.realforeclose.com at 9:00 AM on the 26th day of October, 2012, the following described property as set forth in said Final Judgment, to wit:

LOT 51, LESS THE WEST 81.15 FEET THEREOF, FIRST AD-

DITION TO OAK SHORES, ACCORDING TO THE PLAT THEREOF RECORDED IN PLAT BOOK 8, PAGES 29 AND 29A, OF THE PUBLIC RECORDS OF SARASOTA COUNTY, FLORIDA, TOGETHER WITH ANY RIGHTS IN THE LAKE DESCRIBED IN QUIT CLAIM DEED RECORDED IN OFFICIAL RECORDS BOOK 496, PAGE 639, OF THE PUBLIC RECORDS OF SARASOTA COUNTY, FLORIDA.

ANY PERSON CLAIMING AN INTEREST IN THE SURPLUS FROM THE SALE, IF ANY, OTHER THAN THE PROPERTY OWNER AS OF THE DATE OF THE LIS PENDENS MUST FILE A CLAIM WITHIN 60 DAYS AFTER THE SALE.

In accordance with the Americans With Disabilities Act, persons needing a reasonable accommodation to participate in this proceeding should contact the Clerk of the Circuit Court no later than seven business days prior to the proceeding at the Sarasota County Courthouse. Telephone 941-861-7425 (Sarasota and Venice) or 1-800-955-8770 via Florida Relay Service.
Dated this 01 day of October, 2012.

By: Wendy Manswell, Esq.
Bar Number: 12027

Submitted by:
LAW OFFICES OF
MARSHALL C. WATSON, P.A.
1800 NW 49th Street, Suite 120
Fort Lauderdale, Florida 33309
Telephone: (954) 453-0365
Facsimile: (954) 771-6052
Toll Free: 1-800-441-2438
DESIGNATED PRIMARY E-MAIL FOR SERVICE PURSUANT TO FLA. R. JUD. ADMIN 2.516
eservice@marshallwatson.com
09-16998
October 5, 12, 2012 12-3824S

SECOND INSERTION

NOTICE OF FORECLOSURE SALE IN THE CIRCUIT COURT OF THE 12TH JUDICIAL CIRCUIT, IN AND FOR SARASOTA COUNTY, FLORIDA

CIVIL DIVISION:
CASE NO.: 2011 CA 009651 NC
THE BANK OF NEW YORK MELLON F/K/A THE BANK OF NEW YORK, AS TRUSTEE FOR THE CERTIFICATEHOLDERS OF CWALT, INC., ALTERNATIVE LOAN TRUST 2005-63,
MORTGAGE PASS-THROUGH CERTIFICATES, SERIES 2005-63,
Plaintiff, vs.
MIREYA C. ALDAY-EAVEY A/K/A MIREYA EAVEY; MICHAEL A. EAVEY A/K/A MICHAEL ANDREW EAVEY; UNKNOWN TENANT; IN POSSESSION OF THE SUBJECT PROPERTY,
Defendant(s).

NOTICE IS HEREBY GIVEN pursuant to Final Judgment of Foreclosure dated the 18th day of September, 2012, and entered in Case No. 2011 CA 009651 NC, of the Circuit Court of the 12TH Judicial Circuit in and for Sarasota County, Florida, wherein THE BANK OF NEW YORK MELLON F/K/A THE BANK OF NEW YORK, AS TRUSTEE FOR THE CERTIFICATEHOLDERS OF CWALT, INC., ALTERNATIVE LOAN TRUST 2005-63, MORTGAGE PASS-THROUGH CERTIFICATES, SERIES 2005-63 is the Plaintiff and MIREYA C. ALDAY-EAVEY A/K/A MIREYA EAVEY, MICHAEL A. EAVEY A/K/A MICHAEL ANDREW EAVEY and UNKNOWN TENANT(S); IN POSSESSION OF THE SUBJECT PROPERTY are defendants. The Clerk of this Court shall sell to the highest and best bidder for cash electronically at www.sarasota.

realforeclose.com at 9:00 AM on the 26th day of October, 2012, the following described property as set forth in said Final Judgment, to wit:

LOT 5, BLOCK 655, 14TH ADDITION TO PORT CHARLOTTE, AS PER PLAT THEREOF RECORDED IN PLAT BOOK 13, PAGE(S) 13, 13A THROUGH 13Q, OF THE PUBLIC RECORDS OF SARASOTA COUNTY, FLORIDA

ANY PERSON CLAIMING AN INTEREST IN THE SURPLUS FROM THE SALE, IF ANY, OTHER THAN THE PROPERTY OWNER AS OF THE DATE OF THE LIS PENDENS MUST FILE A CLAIM WITHIN 60 DAYS AFTER THE SALE.

In accordance with the Americans With Disabilities Act, persons needing a reasonable accommodation to participate in this proceeding should contact the Clerk of the Circuit Court no later than seven business days prior to the proceeding at the Sarasota County Courthouse. Telephone 941-861-7425 (Sarasota and Venice) or 1-800-955-8770 via Florida Relay Service.
Dated this 1 day of October, 2012.

By: Marjorie Levine, Esq.
Bar Number: 96413

Submitted by:
LAW OFFICES OF
MARSHALL C. WATSON, P.A.
1800 NW 49th Street, Suite 120
Fort Lauderdale, Florida 33309
Telephone: (954) 453-0365
Facsimile: (954) 771-6052
Toll Free: 1-800-441-2438
DESIGNATED PRIMARY E-MAIL FOR SERVICE PURSUANT TO FLA. R. JUD. ADMIN 2.516
eservice@marshallwatson.com
11-08223
October 5, 12, 2012 12-3828S

SECOND INSERTION

NOTICE OF RESCHEDULED FORECLOSURE SALE IN THE CIRCUIT COURT OF THE TWELFTH JUDICIAL CIRCUIT IN AND FOR SARASOTA COUNTY, FLORIDA
CIVIL ACTION
CASE NO.: 58-2011-CA-007975 NC
DIVISION: C

REGIONS BANK DBA AMSOUTH BANK,
Plaintiff, vs.
KARL MCCLINTOCK A/K/A KARL L. MCCLINTOCK, et al,
Defendant(s).

NOTICE IS HEREBY GIVEN pursuant to an Order Rescheduling Foreclosure Sale dated September 27, 2012 and entered in Case No. 58-2011-CA-007975 NC of the Circuit Court of the TWELFTH Judicial Circuit in and for SARASOTA County, Florida wherein REGIONS BANK DBA AMSOUTH BANK, is the Plaintiff and KARL MCCLINTOCK A/K/A KARL L. MCCLINTOCK; PAULA MCCLINTOCK A/K/A PAULA A MCCLINTOCK; REGIONS BANK; SOUTH VENICE CIVIC ASSOCIATION, INC.; are the Defendants, The Clerk will sell to the highest and best bidder for cash at WWW.SARASOTA.REALFORECLOSE.COM at 9:00AM, on 10/31/2012, the following described property as set forth in said Final Judgment:

LOTS 4003, 4004, 4005 AND 4011, SOUTH VENICE, UNIT NO. 14, ACCORDING TO THE PLAT THEREOF RECORDED IN PLAT BOOK 6, PAGE 50, OF THE PUBLIC RECORDS OF SARASOTA COUNTY, FLORIDA,

A/K/A 4161 MERCURY ROAD, VENICE, FL 34293
Any person claiming an interest in the surplus from the sale, if any, other than the property owner as of the date of the Lis Pendens must file a claim within sixty (60) days after the sale.

In accordance with the Americans With Disabilities Act, persons needing a reasonable accommodation to participate in this proceeding should contact the Clerk of the Circuit Court no later than seven business days prior to the proceeding at the Sarasota County Courthouse. Telephone 941-861-7425 (Sarasota and Venice) or 1-800-955-8770 via Florida Relay Service.

By: John Jefferson
Florida Bar No. Pending

RONALD R WOLFE & ASSOCIATES, P.L.
P.O. Box 25018
Tampa, Florida 33622-5018
(813) 251-4766
F11020482
October 5, 12, 2012 12-3857S

SECOND INSERTION

NOTICE OF FORECLOSURE SALE IN THE CIRCUIT COURT OF THE 12TH JUDICIAL CIRCUIT, IN AND FOR SARASOTA COUNTY, FLORIDA
CIVIL DIVISION:
CASE NO.: 2008 CA 018323 NC
COUNTRYWIDE HOME LOANS, INC.,
Plaintiff, vs.

LAWRENCE F. ENGELL, JR. A/K/A LAWRENCE E. ENGELL, JR. A/K/A LAWRENCE F. ENGELL; UNKNOWN SPOUSE OF LAWRENCE F. ENGELL JR. A/K/A LAWRENCE E. ENGELL, JR. A/K/A LAWRENCE F. ENGELL; UNKNOWN TENANT(S) IN POSSESSION OF THE SUBJECT PROPERTY,
Defendant(s).

NOTICE IS HEREBY GIVEN pursuant to Final Judgment of Foreclosure dated the 18th day of September 2012 and entered in Case No. 2008 CA 018323 NC, of the Circuit Court of the 12TH Judicial Circuit in and for Sarasota County, Florida, wherein BAC HOME LOANS SERVICING, FP F/K/A COUNTRYWIDE HOME LOANS INC is the Plaintiff and LAWRENCE F. ENGELL, JR. A/K/A LAWRENCE E. ENGELL JR A/K/A LAWRENCE F. ENGELL, UNKNOWN TENANT(S) N/K/A JESSIE POTTER and UNKNOWN TENANT(S) IN POSSESSION OF THE SUBJECT PROPERTY are defendants. The Clerk of this Court shall sell to the highest and best bidder for cash electronically at www.sarasota.realforeclose.com at 9:00 AM on the 25th day of October 2012 the following described property as set forth in said Final Judgment, to wit:

EAST 75 FEET OF LOT 1, BLOCK 942, 15TH ADDITION TO PORT CHARLOTTE SUBDIVISION, A SUBDIVISION ACCORDING TO THE PLAT THEREOF AS RECORDED IN PLAT BOOK 13, PAGES 14, 14A-14B, OF THE PUBLIC RECORDS OF SARASOTA COUNTY, FLORIDA.

ANY PERSON CLAIMING AN INTEREST IN THE SURPLUS FROM THE SALE, IF ANY, OTHER THAN THE PROPERTY OWNER AS OF THE DATE OF THE LIS PENDENS MUST FILE A CLAIM WITHIN 60 DAYS AFTER THE SALE.

In accordance with the Americans With Disabilities Act, persons needing a reasonable accommodation to participate in this proceeding should contact the Clerk of the Circuit Court no later than seven business days prior to the proceeding at the Sarasota County Courthouse. Telephone 941-861-7425 (Sarasota and Venice) or 1-800-955-8770 via Florida Relay Service.

Dated this 28 day of September, 2012.

By: Wendy Manswell, Esq.
Bar Number: 12027

Submitted by:
LAW OFFICES OF
MARSHALL C. WATSON, P.A.
1800 NW 49th Street, Suite 120
Fort Lauderdale, Florida 33309
Telephone: (954) 453-0365
Facsimile: (954) 771-6052
Toll Free: 1-800-441-2438
DESIGNATED PRIMARY E-MAIL
FOR SERVICE PURSUANT TO FLA.
R. JUD. ADMIN 2.516
eservice@marshallwatson.com
08-50422
October 5, 12, 2012 12-3784S

SECOND INSERTION

AMENDED NOTICE OF FORECLOSURE SALE IN THE CIRCUIT COURT IN AND FOR SARASOTA COUNTY, FLORIDA

CASE NO: 2008-CA-013282-NC/C
THE BANK OF NEW YORK, AS TRUSTEE FOR THE BENEFIT OF THE CERTIFICATEHOLDERS CWALT, ALTERNATIVE LOAN TRUST 2007-OA6, MORTGAGE PASS-THROUGH CERTIFICATES, SERIES 2007-OA6
Plaintiff, vs.
SLAWOMIR S. KASZUBOWSKI A/K/A SLAWOMIR KASZUBOWSKI; UNKNOWN SPOUSE OF SLAWOMIR S. KASZUBOWSKI A/K/A SLAWOMIR KASZUBOWSKI; UNKNOWN TENANT I; UNKNOWN TENANT II; VILLAGIO CONDOMINIUM ASSOCIATION, INC., and any unknown heirs, devisees, grantees, creditors, and other unknown persons or unknown spouses claiming by, through and under any of the above-named Defendants,
Defendants.

NOTICE is hereby given that the Clerk of the Circuit Court of Sarasota County, Florida, will on the 19th day of October 2012, at 9:00am www.sarasota.realforeclose.com in accordance with Chapter 45 Florida Statutes, offer for sale and sell at public outcry to the highest and best bidder for cash, the following-described property situate in Sarasota County, Florida:

Unit 205, Building 4, VILLAGIO, a Condominium, according to the Declaration of Condominium recorded in Official Records Instrument #2003257048 and amendments thereto, Public Records of Sarasota County, Florida. Together with an undivided interest in the common elements appurtenant thereto, as set forth in said Declaration.

pursuant to the Final Judgment entered in a case pending in said Court, the style of which is indicated above.

Any person or entity claiming an interest in the surplus, if any, resulting from the foreclosure sale, other than the property owner as of the date of the Lis Pendens, must file a claim on same with the Clerk of Court within 60 days after the foreclosure sale.

In accordance with the Americans With Disabilities Act, persons needing a reasonable accommodation to participate in this proceeding should contact the Clerk of the Circuit Court no later than seven business days prior to the proceeding at the Sarasota County Courthouse. Telephone 941-861-7425 (Sarasota and Venice) or 1-800-955-8770 via Florida Relay Service.

DATED this 1 day of October, 2012.

/s/ MARY E. YOUNG, Esquire
BUTLER & HOSCH, P.A.
3185 South Conway Road, Suite E
Orlando, Florida 32812
Telephone: (407) 381-5200
Fax: (407) 381-5577
Florida Bar No: 599891
Service Emails:
my599891@butlerandhosch.com
FLpleadings@butlerandhosch.com
B&H # 260851
October 5, 12, 2012 12-3817S

SECOND INSERTION

NOTICE OF SALE IN THE CIRCUIT COURT OF THE TWELFTH JUDICIAL CIRCUIT IN AND FOR SARASOTA COUNTY, FLORIDA
CIVIL DIVISION
Case #: 2010-CA-008531-NC
DIVISION: C

BAC Home Loans Servicing, L.P. f/k/a Countrywide Home Loans Servicing, L.P.
Plaintiff, -vs.-

Mark R. Aten and Allison L. Aten, Husband and Wife; Mortgage Electronic Registration Systems, Inc., as Nominee for Silver State Financial Services, Inc. d/b/a Silver State Mortgage; Unknown Tenants in Possession #1; Unknown Tenants in Possession #2; If living, and all Unknown Parties claiming by, through, under and against the above named Defendant(s) who are not known to be dead or alive, whether said Unknown Parties may claim an interest as Spouse, Heirs, Devisees, Grantees, or Other Claimants
Defendant(s).

NOTICE IS HEREBY GIVEN pursuant to an Order of Final Judgment of Foreclosure dated September 24, 2012, entered in Civil Case No. 2010-CA-008531-NC of the Circuit Court of the 12th Judicial Circuit in and for Sarasota County, Florida, wherein BAC Home Loans Servicing, L.P. f/k/a Countrywide Home Loans Servicing, L.P., Plaintiff and Mark R. Aten and Allison L. Aten, Husband and Wife are defendant(s), I, will sell to the highest and best bidder for cash VIA THE INTERNET AT WWW.SARASOTA.REALFORECLOSE.COM, AT 9:00 A.M. on November 1, 2012, the following described property as set forth in said Final Judgment, to-wit:

LOT 7694 AND 7695, SOUTH VENICE UNIT NO. 28, AS PER PLAT THEREOF AS RECORDED IN PLAT BOOK 6, PAGE 77, OF THE PUBLIC RECORDS OF SARASOTA COUNTY, FLORIDA

ANY PERSON CLAIMING AN INTEREST IN THE SURPLUS FROM THE SALE, IF ANY, OTHER THAN THE PROPERTY OWNER AS OF THE DATE OF THE LIS PENDENS MUST FILE A CLAIM WITHIN 60 DAYS AFTER THE SALE.

In accordance with the Americans With Disabilities Act, persons needing a reasonable accommodation to participate in this proceeding should contact the Clerk of the Circuit Court no later than seven business days prior to the proceeding at the Sarasota County Courthouse. Telephone 941-861-7425 (Sarasota and Venice) or 1-800-955-8770 via Florida Relay Service.

By: Ella Roberts, Esquire
FL Bar # 75943

SHAPIRO, FISHMAN & GACHÉ, LLP
Attorneys for Plaintiff
2424 North Federal Highway,
Suite 360
Boca Raton, Florida 33431
Telephone: (561) 998-6700
Fax: (561) 998-6707
10-179534 FCO1 CWF
October 5, 12, 2012 12-3849S

SECOND INSERTION

NOTICE OF SALE IN THE CIRCUIT COURT OF THE TWELFTH JUDICIAL CIRCUIT IN AND FOR SARASOTA COUNTY, FLORIDA
CIVIL DIVISION
Case #: 2009-CA-005936-NC
DIVISION: C

Deutsche Bank National Trust Company, as Trustee for Long Beach Mortgage Loan Trust 2005-2
Plaintiff, -vs.-

Jose Maria Eduardo Hernandez; Mortgage Electronic Registration Systems, Inc.; Gary A. Weisberg, d/b/a Trail Properties; State of Florida Department of Revenue; Unknown Parties in Possession #1; Unknown Parties in Possession #2; If living, and all Unknown Parties claiming by, through, under and against the above named Defendant(s) who are not known to be dead or alive, whether said Unknown Parties may claim an interest as Spouse, Heirs, Devisees, Grantees, or Other Claimants
Defendant(s).

NOTICE IS HEREBY GIVEN pursuant to an Order rescheduling foreclosure sale dated June 18, 2012, entered in Civil Case No. 2009-CA-005936-NC of the Circuit Court of the 12th Judicial Circuit in and for Sarasota County, Florida, wherein Deutsche Bank National Trust Company, as Trustee for Long Beach Mortgage Loan Trust 2005-2, Plaintiff and Jose Maria Eduardo Hernandez are defendant(s), I, Clerk of Court, KAREN E. RUSHING, will sell to the highest and best bidder for cash VIA THE INTERNET AT WWW.SARASOTA.REALFORECLOSE.COM, AT 9:00 A.M. on November 2, 2012, the following described property as set forth in said Final Judgment, to-wit:

LOT 110, GREEN MANOR ESTATES SUBDIVISION, UNIT NO. 3, ACCORDING TO THE PLAT THEREOF, RECORDED IN PLAT BOOK 15, PAGES 7 AND 7A, OF THE PUBLIC RECORDS OF SARASOTA COUNTY, FLORIDA.

ANY PERSON CLAIMING AN INTEREST IN THE SURPLUS FROM THE SALE, IF ANY, OTHER THAN THE PROPERTY OWNER AS OF THE DATE OF THE LIS PENDENS MUST FILE A CLAIM WITHIN 60 DAYS AFTER THE SALE.

In accordance with the Americans With Disabilities Act, persons needing a reasonable accommodation to participate in this proceeding should contact the Clerk of the Circuit Court no later than seven business days prior to the proceeding at the Sarasota County Courthouse. Telephone 941-861-7425 (Sarasota and Venice) or 1-800-955-8770 via Florida Relay Service.

By: Ella Roberts, Esquire
FL Bar # 75943

SHAPIRO, FISHMAN & GACHÉ, LLP
Attorneys for Plaintiff
2424 North Federal Highway,
Suite 360
Boca Raton, Florida 33431
Telephone: (561) 998-6700
Fax: (561) 998-6707
09-126118 FCO1 W50
October 5, 12, 2012 12-3851S

SECOND INSERTION

NOTICE OF SALE IN THE CIRCUIT COURT OF THE TWELFTH JUDICIAL CIRCUIT IN AND FOR SARASOTA COUNTY, FLORIDA
CIVIL DIVISION
Case #: 2011-CA-004912-NC
DIVISION: C

Regions Bank d/b/a Regions Mortgage, Successor by Merger to Union Planters Bank, National Association
Plaintiff, -vs.-
Frederick D. Ramirez and Linda Terzich, Husband and Wife; First Tennessee Bank National Association, Successor-in-Interest to First Horizon Home Loan Corporation; Unknown Tenants in Possession #1; If living, and all Unknown Parties claiming by, through, under and against the above named Defendant(s) who are not known to be dead or alive, whether said Unknown Parties may claim an interest as Spouse, Heirs, Devisees, Grantees, or Other Claimants
Defendant(s).

NOTICE IS HEREBY GIVEN pursuant to an Order of Final Judgment of Foreclosure dated September 24, 2012, entered in Civil Case No. 2011-CA-004912-NC of the Circuit Court of the 12th Judicial Circuit in and for Sarasota County, Florida, wherein Regions Bank d/b/a Regions Mortgage, Successor by Merger to Union Planters Bank, National Association, Plaintiff and Frederick D. Ramirez and Linda Terzich, Husband and Wife are defendant(s), I, will sell to the highest and best bidder for cash VIA THE INTERNET AT WWW.SARASOTA.REALFORECLOSE.COM, AT 9:00 A.M. on October 31, 2012, the following described property as set forth in said Final Judgment, to-wit:

LOT 138, RIDGEWOOD ESTATES, 2ND ADDITION, ACCORDING TO THE MAP OR PLAT THEREOF, AS RECORDED IN PLAT BOOK 12, PAGE 9, OF THE PUBLIC RECORDS OF SARASOTA COUNTY, FLORIDA.

ANY PERSON CLAIMING AN INTEREST IN THE SURPLUS FROM THE SALE, IF ANY, OTHER THAN THE PROPERTY OWNER AS OF THE DATE OF THE LIS PENDENS MUST FILE A CLAIM WITHIN 60 DAYS AFTER THE SALE.

In accordance with the Americans With Disabilities Act, persons needing a reasonable accommodation to participate in this proceeding should contact the Clerk of the Circuit Court no later than seven business days prior to the proceeding at the Sarasota County Courthouse. Telephone 941-861-7425 (Sarasota and Venice) or 1-800-955-8770 via Florida Relay Service.

By: Ella Roberts, Esquire
FL Bar # 75943

SHAPIRO, FISHMAN & GACHÉ, LLP
Attorneys for Plaintiff
2424 North Federal Highway,
Suite 360
Boca Raton, Florida 33431
Telephone: (561) 998-6700
Fax: (561) 998-6707
11-215982 FCO1 UPN
October 5, 12, 2012 12-3854S

SECOND INSERTION

NOTICE OF FORECLOSURE SALE IN THE CIRCUIT COURT OF THE 12TH JUDICIAL CIRCUIT, IN AND FOR SARASOTA COUNTY, FLORIDA
CIVIL DIVISION:
CASE NO.:

58-2010-CA-007960 NC
THE BANK OF NEW YORK MELLON FKA THE BANK OF NEW YORK AS SUCCESSOR TO JP MORGAN CHASE BANK, N.A. AS TRUSTEE FOR HOLDERS OF SAMI II 2006-AR6, MTG PASS-THROUGH CERTS, SERIES 2006-AR6,
Plaintiff, vs.

DAVID MILLER A/K/A DAVID L. MILLER; CLERK OF THE COURTS OF SARASOTA COUNTY, FLORIDA; STATE OF FLORIDA DEPARTMENT OF REVENUE; UNITED STATES OF AMERICA DEPARTMENT OF THE TREASURY; STEPHANIE MILLER; UNKNOWN SPOUSE OF DAVID MILLER A/K/A DAVID L. MILLER; UNKNOWN TENANT(S); IN POSSESSION OF THE SUBJECT PROPERTY,
Defendant(s).

NOTICE IS HEREBY GIVEN pursuant to Final Judgment of Foreclosure dated the 18th day of September, 2012, and entered in Case No. 58-2010-CA-007960 NC, of the Circuit Court of the 12TH Judicial Circuit in and for Sarasota County, Florida, wherein THE BANK OF NEW YORK MELLON FKA THE BANK OF NEW YORK AS SUCCESSOR TO JP MORGAN CHASE BANK, N.A. AS TRUSTEE FOR HOLDERS OF SAMI II 2006-AR6, MTG PASS-THROUGH CERTS, SERIES 2006-AR6 is the Plaintiff and DAVID MILLER A/K/A DAVID L. MILLER, CLERK OF THE COURTS OF SARASOTA COUNTY, FLORIDA, STATE OF FLORIDA

DEPARTMENT OF REVENUE, UNITED STATES OF AMERICA DEPARTMENT OF THE TREASURY, STEPHANIE MILLER, UNKNOWN SPOUSE OF DAVID MILLER A/K/A DAVID L. MILLER and UNKNOWN TENANT(S) IN POSSESSION OF THE SUBJECT PROPERTY are defendants. The Clerk of this Court shall sell to the highest and best bidder for cash electronically at www.sarasota.realforeclose.com at 9:00 AM on the 26th day of October, 2012, the following described property as set forth in said Final Judgment, to wit:

Exhibit "A"
Situat, lying and being in the County of Sarasota, State of Florida, and described as follows:
The North 105 feet to the following described property: Begin at the Northwest corner of Lot 116, First Addition to Oak Shores, recorded in Plat Book 8, Pages 29 and 29 A, of the Public Records of Sarasota County, Florida; thence North 89 degrees 58' West, 50 feet; thence North 210 feet; thence South 89 degrees 58' East, 275 feet more or less to shore of Canal B; thence Southerly along the Shoreline of Canal B to the North line of said Lot 116; thence North 89 degrees 56' West, 160 feet more or less to the Point of Beginning. Less the West 25 feet for road assessment. Lying and being in the NE 1/4 Section 28, Township 38 South, Range 18 East, Sarasota County, Florida. Together with a perpetual non-exclusive for ingress and egress over the West 25 feet of the following described parcel of land: Begin at the Northwest corner of Lot 116, First addition to Oak Shores, as per Plat Book 8, Pages 29 and 29A, of the Public Records of Sarasota County, Florida; thence North 89

degrees 58' West, 50 feet; thence North 210 feet; thence South 89 degrees 58' East, 275 feet more or less, to shore of Canal B; thence Southerly along the Shoreline of Canal B to the North of said Lot 116; thence North 89 degrees 58' West, 160 feet more or less, to the Point of Beginning.

Be the same, more or less, but subject to all legal highways.
Parcel No. 0054-01-0030
Commonly known as: 701 Locklear Avenue, Sarasota, Florida 34237

ANY PERSON CLAIMING AN INTEREST IN THE SURPLUS FROM THE SALE, IF ANY, OTHER THAN THE PROPERTY OWNER AS OF THE DATE OF THE LIS PENDENS MUST FILE A CLAIM WITHIN 60 DAYS AFTER THE SALE.

In accordance with the Americans With Disabilities Act, persons needing a reasonable accommodation to participate in this proceeding should contact the Clerk of the Circuit Court no later than seven business days prior to the proceeding at the Sarasota County Courthouse. Telephone 941-861-7425 (Sarasota and Venice) or 1-800-955-8770 via Florida Relay Service.

Dated this 02 day of October, 2012.
By: Lucetta Pierre-Louis, Esq.
Bar Number: 86807

Submitted by:
LAW OFFICES OF
MARSHALL C. WATSON, P.A.
1800 NW 49th Street, Suite 120
Fort Lauderdale, Florida 33309
Telephone: (954) 453-0365
Facsimile: (954) 771-6052
Toll Free: 1-800-441-2438
DESIGNATED PRIMARY E-MAIL
FOR SERVICE PURSUANT TO FLA.
R. JUD. ADMIN 2.516
eservice@marshallwatson.com
10-11106
October 5, 12, 2012 12-3829S

SECOND INSERTION

NOTICE OF FORECLOSURE SALE IN THE CIRCUIT COURT OF THE TWELFTH JUDICIAL CIRCUIT IN AND FOR SARASOTA COUNTY, FLORIDA

Case No. 2008-CA-014105 NC
Federal Home Loan Mortgage Corporation
Plaintiff Vs.
DANIEL W. DUBBS;
DEBRA K. DUBBS; et al
Defendants

NOTICE IS HEREBY GIVEN that, in accordance with the Final Judgment of Foreclosure dated September 24, 2012, and entered in Case No. Case No. 2008-CA-014105 NC, of the Circuit Court of the 12th Judicial Circuit in and for SARASOTA County, Florida, Federal Home Loan Mortgage Corporation is Plaintiff and DANIEL W. DUBBS; DEBRA K. DUBBS; et al; are defendants. The Clerk of Court will sell to the highest and best bidder for cash by electronic sale at www.sarasota.realforeclose.com at 9:00 a.m., on the 29 day of October, 2012, the following described property as set forth in said Final Judgment, to wit:

PART OF LOTS 1 AND 2, BLOCK "D", GLENWOOD PARK, UNIT NO. 1, MORE PARTICULARLY DESCRIBED AS FOLLOWS. COMMENCE AT THE NORTHWEST CORNER OF SAID LOT 1, BEING THE POINT OF INTERSECTION OF THE EAST LINE OF EAST AVENUE AND THE SOUTH LINE OF WOOD STREET IN THE CITY OF SARASOTA, FLORIDA FOR A POINT OF BEGINNING; THENCE SOUTH ALONG THE EAST LINE OF SAID EAST AVENUE A DISTANCE OF 108 FEET TO THE

SOUTHWEST CORNER OF SAID LOT 2. THENCE EAST ALONG THE SOUTH LINE OF LOT 2, A DISTANCE OF 79.65 FEET TO A POINT; THENCE NORTH ACROSS LOTS 2 AND 1, A DISTANCE OF 108 FEET TO THE SOUTH LINE OF WOOD STREET; THENCE WEST ALONG THE SAID SOUTH LINE OF WOOD STREET A DISTANCE OF 78.9 FEET TO THE POINT OF BEGINNING; BEING A PART OF LOTS 1 AND 2 OF BLOCK "D", GLENWOOD PARK, UNIT NO. 1, AS PER PLAT THEREOF RECORDED IN PLAT BOOK 2, PAGE 134, OF THE PUBLIC RECORDS OF SARASOTA COUNTY, FLORIDA. LESS THAT CERTAIN LAND DESCRIBED IN WARRANTY DEED TO THE CITY OF SARASOTA RECORDED IN OFFICIAL RECORDS BOOK 2422, PAGE 412, OF THE PUBLIC RECORDS OF SARASOTA COUNTY, FLORIDA AND MORE PARTICULARLY DESCRIBED AS FOLLOWS: COMMENCING AT THE NORTHEAST CORNER OF LOT 1, BLOCK "D", GLENWOOD PARK SUBDIVISION AS RECORDED IN PLAT BOOK 2, PAGE 134 OF THE PUBLIC RECORDS OF SARASOTA COUNTY, FLORIDA, GO WESTWARDLY ALONG THE NORTHERN LINE OF SAID LOT 1 AND THE SOUTHERLY RIGHT OF WAY LINE OF WOOD STREET 105.4 FT. TO THE POINT OF BEGINNING, THENCE CONTINUE 12 FT. ALONG SAID LINE TO THE

WESTERLY LINE OF SAID LOT 1 AND THE EASTERLY RIGHT OF WAY OF EAST AVENUE; THENCE GO SOUTHERLY ALONG THE WESTERLY LINE OF SAID LOT 1 AND THE EASTERLY RIGHT OF WAY OF EAST AVENUE 12 FT.; THENCE GO 16.96 FT., MORE OR LESS TO THE POINT OF BEGINNING. MORE COMMONLY KNOWN AS 2104 WOOD STREET, SARASOTA, FLORIDA TAX ID: 2034050038 AS DESCRIBED IN MORTGAGE INSTRUMENT NO. 2005277745

Any person claiming an interest in the surplus from the sale, if any, other than the property owner as of the date of the lis pendens must file a claim within 60 days after the sale.

This notice is provided pursuant to Administrative Order No. 2.065.

In accordance with the Americans With Disabilities Act, persons needing a reasonable accommodation to participate in this proceeding should contact the Clerk of the Circuit Court no later than seven business days prior to the proceeding at the Sarasota County Courthouse. Telephone 941-861-7425 (Sarasota and Venice) or 1-800-955-8770 via Florida Relay Service.

Dated this 28 day of September, 2012.

By: Connie Delisser, Esq.
Bar No.: 293740
FLEService@udren.com
fleservice@delisser@udren.com
UDREN LAW OFFICES, P.C.
4651 Sheridan Street, Suite 460
Hollywood, FL 33021
Telephone 954-378-1757
Fax 954-378-1758
File # 10120820
October 5, 12, 2012 12-3821S

SECOND INSERTION

NOTICE OF ACTION
IN THE CIRCUIT COURT OF THE
12TH JUDICIAL CIRCUIT, IN
AND FOR SARASOTA COUNTY,
FLORIDA
CIVIL DIVISION
CASE NO.: 58-2011-CA-008709 NC
ONWEST BANK, FSB,
Plaintiff, vs.
DONALD J. ENGELS, AS
SUCCESSOR TRUSTEE
OF THE AMENDED AND
RESTATED REVOCABLE TRUST
AGREEMENT OF GENEVIEVE
SPAIN DATED SEPTEMBER 22,
1995, et al,
Defendants.

TO:
UNKNOWN BENEFICIARIES OF
THE AMENDED AND RESTATED
REVOCABLE TRUST AGREEMENT
OF GENEVIEVE SPAIN DATED SEP-
TEMBER 22, 1995
LAST ADDRESS UNKNOWN
CURRENT RESIDENCE UNKNOWN

YOU ARE NOTIFIED that an action
for Foreclosure of Mortgage on the fol-
lowing described property:
UNIT 366, BUILDING 29,
FARMINGTON VISTAS AT
THE PLANTATION, ACCORD-
ING TO THE DECLARATION
OF CONDOMINIUM THERE-
OF RECORDED IN OFFICIAL
RECORD BOOK 1499, PAGE
1332, AND AS AMENDED,
PUBLIC RECORD OF SARA-
SOTA COUNTY, FLORIDA.

has been filed against you and you
are required to serve a copy of your
written defenses, if any, to it, on
Marshall C. Watson, P.A., Attorney
for Plaintiff, whose address is 1800
NW 49TH STREET, SUITE 120,
FT. LAUDERDALE FL 33309 on
or before 11/5/2012 a date which
is within thirty (30) days after the
first publication of this Notice in the
GULF COAST BUSINESS REVIEW
and file the original with the Clerk
of this Court either before service on
Plaintiff's attorney or immediately
thereafter; otherwise a default will be
entered against you for the relief
demanded in the complaint.

In accordance with the Americans
With Disabilities Act, persons need-
ing a reasonable accommodation to
participate in this proceeding should
contact the Clerk of the Circuit
Court no later than seven business
days prior to the proceeding at the
Sarasota County Courthouse. Tele-
phone 941-861-7425 (Sarasota and
Venice) or 1-800-955-8770 via Flori-
da Relay Service.

WITNESS my hand and the seal of
this Court this 27 day of September,
2012.

Karen E. Rushing
As Clerk of the Court
(SEAL) By M. Foulks
As Deputy Clerk

MARSHALL C. WATSON, P.A.,
Attorney for Plaintiff
1800 NW 49TH STREET, SUITE 120,
FT. LAUDERDALE FL 33309
11-11433
October 5, 12, 2012 12-3785S

SECOND INSERTION

NOTICE OF ACTION
IN THE CIRCUIT COURT OF THE
TWELFTH JUDICIAL CIRCUIT
IN AND FOR SARASOTA COUNTY,
FLORIDA
CIVIL DIVISION
CASE NO.: 58-2012-CA-003522 NC
GENERATION MORTGAGE
COMPANY,
Plaintiff, v.
THE UNKNOWN SPOUSE,
HEIRS, DEVISEES, GRANTEEES,
ASSIGNEES, LIENORS,
CREDITORS, TRUSTEES
AND ALL OTHER PARTIES
CLAIMING AN INTEREST BY,
THROUGH, UNDER OR AGAINST
THE ESTATE OF DONALD E.
HOASTETTLER A/K/A DONALD
EDMUND HOSTETTLER; et al.,
Defendant(s).

TO: THE UNKNOWN SPOUSE,
HEIRS, DEVISEES, GRANTEEES, AS-
SIGNEES, LIENOR, CREDITORS,
TRUSTEES AND ALL OTHER PART-
TIES CLAIM AN INTEREST BY,
THROUGH, UNDER OR AGAINST
THE ESTATE OF DONALD E.
HOSTETTLER A/K/A DONALD ED-
MUND HOSTETTLER
Subject Property Address:

605 Briarwood Road
Venice, FL 34293
Last Known Address: Unknown

ALL OTHER UNKNOWN PAR-
TIES CLAIMING INTERESTS BY,
THROUGH, UNDER, AND AGAINST
A NAMED DEFENDANT(S) WHO
ARE NOT KNOWN TO BE DEAD
OR ALIVE, WHETHER SAME UN-
KNOWN PARTIES MAY CLAIM AN
INTEREST AS SPOUSES, HEIRS,
DEVISEES, GRANTEEES, OR OTHER
CLAIMANTS

Last Known Address: Unknown
Current Address: Unknown

YOU ARE NOTIFIED that an ac-
tion to foreclose a mortgage on the
following property in Sarasota County,
Florida:

LOT 1351, VENICE GARDENS
UNIT NO. 29, ACCORD-
ING TO THE MAP OR PLAT
THEREOF, AS RECORDED IN

SECOND INSERTION

NOTICE OF FORECLOSURE SALE
IN THE CIRCUIT COURT OF THE
TWELFTH JUDICIAL CIRCUIT IN
AND FOR SARASOTA COUNTY,
FLORIDA
GENERAL JURISDICTION
DIVISION
CASE NO. 2009 CA 016201 NC
BAC HOME LOANS SERVICING,
L.P. F/K/A COUNTRYWIDE HOME
LOANS SERVICING, L.P.,
Plaintiff, vs.
RICARDO MONTANEZ, et al.
Defendant.

NOTICE IS HEREBY GIVEN pursu-
ant to a Final Judgment of Foreclosure
dated JUNE 11, 2012, and entered
in 2009 CA 016201 NC of the Circuit
Court of the Twelfth Judicial Circuit
in and for Sarasota County, Florida,
wherein BAC HOME LOANS SER-
VICING, L.P. F/K/A COUNTRYWIDE
HOME LOANS SERVICING, L.P., is
the Plaintiff and RICARDO MON-
TANEZ; UNKNOWN SPOUSE OF
RICARDO MONTANEZ; CROCKER'S
LAKE COMMUNITY ASSOCIATION,
INC.; PALMER RANCH MASTER
PROPERTY OWNERS ASSOCIA-
TION, INC.; VINTAGE GRAND CONDO-
MINIUM ASSOCIATION, INC.;
JOHN DOE N/K/A SHANE DENIZA-
RD are the Defendant(s). Karen Rush-
ing as the Clerk of the Circuit Court will
sell to the highest and best bidder for
cash www.sarasota.realforeclose.com,
at 09:00 AM on OCTOBER 24, 2012,
the following described property as set
forth in said Final Judgment, to wit:

UNIT 17, BUILDING 11, VIN-
TAGE GRAND CONDOMIN-
IUM, ACCORDING TO THE
DECLARATION OF CONDO-
MINIUM RECORDED IN OF-
FICIAL RECORDS INSTRU-
MENT NO. 2005281688, AND
AMENDMENTS THERETO,
OF THE PUBLIC RECORDS
OF SARASOTA COUNTY,
FLORIDA

Any person claiming an interest in the
surplus from the sale, if any, other than
the property owner as of the date of the
lis pendens must file a claim within 60
days after the sale.

In accordance with the Americans
With Disabilities Act, persons need-
ing a reasonable accommodation to
participate in this proceeding should
contact the Clerk of the Circuit
Court no later than seven business
days prior to the proceeding at the
Sarasota County Courthouse. Tele-
phone 941-861-7425 (Sarasota and
Venice) or 1-800-955-8770 via Flori-
da Relay Service.

Dated this 2nd day of October, 2012.

By: Ivy J. Papsidero
FL Bar No, 47817
for Jonathan Meisels
Florida Bar: 29235

ROBERTSON, ANSCHUTZ
& SCHNEID, PL
Attorneys for Plaintiff
3010 North Military Trail, Suite 300
Boca Raton, Florida 33431
Telephone: 561-241-6901
Fax: 561-241-9181
10-01848
October 5, 12, 2012 12-3848S

SECOND INSERTION

AMENDED NOTICE OF SALE
IN THE CIRCUIT COURT OF THE
TWELFTH JUDICIAL CIRCUIT IN
AND FOR SARASOTA COUNTY,
STATE OF FLORIDA
CASE NO: 2012 CA 002719 NC
JAMES T. VAN WINKLE, JR. and
MARY E. VAN WINKLE, AS
TRUSTEES UAD 3/09/2001,
Plaintiff, vs.
PATRICIA BRISTOL nka
PATRICIA WATSON, CITY OF
SARASOTA, et al.
Defendant(s.)

NOTICE IS HEREBY GIVEN pursu-
ant to the Final Judgment/Order of
Foreclosure dated August 20, 2012, and
that Order rescheduling the foreclosure
sale dated October 1, 2012, entered in
Civil Case No. 2012 CA 002719 NC of
the Circuit Court of the Twelfth Judi-
cial Circuit in and for Sarasota County,
Florida, wherein JAMES T. VAN WIN-
KLE, JR. and MARY E. VAN WINKLE,
AS TRUSTEES UAD 3/09/2001, are
the Plaintiffs and PATRICIA BRISTOL
nka PATRICIA WATSON, et al, and
any and all known parties are Defen-
dants. I will sell the following property
located in Sarasota County, Florida:

Lot 1 and 2, Block L, AMARYL-
LIS PARK SUBDIVISION, as
recorded in Plat book 2, Page 56,
of the Public Records of Sarasota
County, Florida.

I will sell to the highest and best bid-
der for cash, via Internet: www.sara-
sota.realforeclose.com, at 9:00 A.M on
October 22, 2012. The highest bidder
shall immediately post with the Clerk,
a deposit equal to 5% of the final bid.
The deposit must be cash or cashier's
check payable to the Clerk of the Circuit
Court. Final payment must be made on
or before 5:00 p.m. of the date of the
sale by cash or cashier's check.

ANY PERSON CLAIMING AN INTER-
EST IN THE SURPLUS FROM
THE SALE, IF ANY, OTHER THAN
THE PROPERTY OWNER AS OF
THE DATE OF THE LIS PENDENS
MUST FILE A CLAIM WITHIN SIXTY
(60) DAYS AFTER THE SALE.

In accordance with the Americans
With Disabilities Act, persons need-
ing a reasonable accommodation to
participate in this proceeding should
contact the Clerk of the Circuit
Court no later than seven business
days prior to the proceeding at the
Sarasota County Courthouse. Tele-
phone 941-861-7425 (Sarasota and
Venice) or 1-800-955-8770 via Florida
Relay Service.

Dated this 2nd day of October, 2012.

/s/ Laurie B Sams
Lauriesams@comcast.net
Attorney for Plaintiff
3859 Bee Ridge Road, Suite 202
Sarasota, FL 34233
(941) 923-1685
Florida Bar # 1366001
October 5, 12, 2012 12-3822S

SECOND INSERTION

NOTICE OF ACTION
IN THE COUNTY COURT OF THE
TWELFTH JUDICIAL CIRCUIT IN
AND FOR SARASOTA COUNTY,
FLORIDA

CASE NO. 2012 CC 5561 NC
SARASOTA VILLAGE GARDENS
CONDOMINIUM ASSOCIATION,
INC., a Florida not-for-profit
corporation,
Plaintiff, vs.

JOANN DAVID, AS PERSONAL
REPRESENTATIVE OF THE
ESTATE OF HELEN M. HAFTL,
DECEASED; MOIRA DOHERTY;
RICHARD WOODMENDER; ANY
UNKNOWN HEIRS, DEVISEES,
GRANTEES, ASSIGNEES,
CREDITORS, LIENORS,
TRUSTEES OF HELEN M. HAFTL,
DECEASED; ALL UNKNOWN
PARTIES CLAIMING INTERESTS
BY, THROUGH, UNDER OR
AGAINST A NAMED DEFENDANT
TO THIS ACTION, OR HAVING
OR CLAIMING TO HAVE ANY
RIGHT, TITLE OR INTEREST
IN THE PROPERTY HEREIN
DESCRIBED; and BANK OF
AMERICA, NA
Defendants.

TO: ANY UNKNOWN HEIRS, DE-
VISEES, GRANTEEES, ASSIGNEES,
CREDITORS, LIENORS, TRUST-
EES OF HELEN M. HAFTL, DE-
CEASED; and ALL UNKNOWN PAR-
TIES CLAIMING INTERESTS BY,
THROUGH, UNDER OR AGAINST
A NAMED DEFENDANT TO THIS
ACTION, OR HAVING OR CLAIM-
ING TO HAVE ANY RIGHT, TITLE
OR INTEREST IN THE PROPERTY
HEREIN DESCRIBED, if living, and
if deceased, any respective unknown
heirs, devisees, grantees, assignees,
creditors, lienors, and trustees, and
all other persons claiming by, through,
under or against them, and all parties
having any right, title or interest in the
property herein described including
heirs, devisees and creditors of them.

The property herein described is as
follows:
Unit No. 80B VILLAGE GAR-
DENS CONDOMINIUM,
Phase II, as per Declaration of
Condominium recorded in Of-
ficial Record Book 1302, Page(s)
1441-1496 incl, and amend-
ments thereto recorded in Of-

SECOND INSERTION

NOTICE OF SALE
IN THE CIRCUIT CIVIL COURT OF
THE TWELFTH JUDICIAL
CIRCUIT OF FLORIDA, IN AND
FOR SARASOTA COUNTY
CIVIL DIVISION
Case No. 58-2009-CA-014025-NC
Division C

WACHOVIA MORTGAGE, FSB.
FKA WORLD SAVINGS BANK
Plaintiff, vs.
STEVEN D. MANSFIELD AND
KATHERYN MANSFIELD,
LAS PALMAS OF SARASOTA
CONDOMINIUM ASSOCIATION,
INC.; NATIONAL CITY BANK,
AND UNKNOWN
TENANTS/OWNERS,
Defendants.

Notice is hereby given, pursuant to Fi-
nal Judgment of Foreclosure for Plain-
tiff entered in this cause on September
26, 2011, in the Circuit Court of Sara-
sota County, Florida, The Clerk of the
Court will sell the property situated in
Sarasota County, Florida described as:
CONDOMINIUM UNIT 3-117,
LAS PALMAS OF SARASOTA,
A LUXURY CONDOMINIUM,
TOGETHER WITH AN UN-
DIVIDED INTEREST IN THE
COMMON ELEMENTS, AC-
CORDING TO THE DECLA-
RATION OF CONDOMINIUM
THEREOF RECORDED IN IN-
STRUMENT #2004247846, AS
AMENDED IN INSTRUMENT
#2004247847, OF THE PUB-
LIC RECORDS OF SARASOTA
COUNTY, FLORIDA.

and commonly known as: 4763 TRA-
VINI CIRCLE UNIT 3-117, SARASO-
TA, FL 34235; including the building,
appartenances, and fixtures located
therein, at public sale, to the highest
and best bidder, for cash, Sales are held
online at: <https://www.sarasota.realforeclose.com>, on October 24, 2012 at
9:00 A.M..

Any persons claiming an interest in
the surplus from the sale, if any, other
than the property owner as of the date
of the lis pendens must file a claim
within 60 days after the sale.

In accordance with the Americans
With Disabilities Act, persons need-
ing a reasonable accommodation to
participate in this proceeding should
contact the Clerk of the Circuit Court
no later than seven business days prior
to the proceeding at the Sarasota County
Courthouse. Telephone 941-861-7425
(Sarasota and Venice) or 1-800-955-
8770 via Florida Relay Service.

Karen E. Rushing
By: Frances Grace Cooper, Esquire
Attorney for Plaintiff

Edward B. Pritchard
(813) 229-0900 x1309
KASS SHULER, P.A.
P.O. Box 800
Tampa, FL 33601-0800
October 5, 12, 2012 12-3819S

SECOND INSERTION

NOTICE TO CREDITORS
IN THE CIRCUIT COURT FOR
SARASOTA COUNTY, FLORIDA
PROBATE DIVISION
File No.: 2012-CP-2700-NC
IN RE: ESTATE OF
MARY J. HOLDER,
Deceased.

The administration of the estate
of MARY J. HOLDER, deceased,
whose date of death was May 16,
2012; File Number 2012CP-2700-
NC, is pending in the Circuit Court
for Sarasota County, Florida, Probate
Division, the address of which is P.O.
Box 3079, Sarasota, FL 34230. The
names and addresses of the personal
representative and the personal rep-
resentative's attorney are set forth
below.

All creditors of the decedent and
other persons having claims or de-
mands against decedent's estate, on
whom a copy of this notice is re-
quired to be served must file their
claims with this court WITHIN
THE LATER OF 3 MONTHS AF-
TER THE TIME OF THE FIRST
PUBLICATION OF THIS NOTICE
OR 30 DAYS AFTER THE DATE
OF SERVICE OF A COPY OF THIS
NOTICE ON THEM.

All other creditors of the decedent

SECOND INSERTION

NOTICE OF FORECLOSURE SALE
IN THE CIRCUIT COURT OF THE
12TH JUDICIAL CIRCUIT, IN
AND FOR SARASOTA COUNTY,
FLORIDA
CIVIL DIVISION:

CASE NO.: 2009 CA 020405 NC
THE BANK OF NEW YORK
MELLON FKA THE BANK OF
NEW YORK AS SUCCESSOR TO
JP MORGAN CHASE BANK, N.A.
AS TRUSTEE OF SAMI II
2006-AR3,
Plaintiff, vs.
GUY M. BROOKS A/K/A GUY
BROOKS; LIBERTY SAVINGS
BANK FSB; KELLY C. BROOKS
A/K/A KELLY BROOKS;
UNKNOWN TENANT(S); IN
POSSESSION OF THE SUBJECT
PROPERTY,
Defendant(s).

NOTICE IS HEREBY GIVEN pur-
suant to Final Judgment of Foreclo-
sure dated the 18th day of September,
2012, and entered in Case No. 2009
CA 020405 NC, of the Circuit Court
of the 12TH Judicial Circuit in and for
Sarasota County, Florida, wherein THE
BANK OF NEW YORK MELLON
FKA THE BANK OF NEW YORK
AS SUCCESSOR TO JP MORGAN
CHASE BANK, N.A. AS TRUSTEE
OF SAMI II 2006-AR3 is the Plaintiff
and GUY M. BROOKS A/K/A GUY
BROOKS, LIBERTY SAVINGS BANK
FSB, KELLY C. BROOKS A/K/A
KELLY BROOKS and UNKNOWN
TENANT(S); IN POSSESSION OF
THE SUBJECT PROPERTY are defen-
dants. The Clerk of this Court shall
sell to the highest and best bidder for
cash electronically at [www.sarasota.
realforeclose.com](http://www.sarasota.realforeclose.com) at 9:00 AM on the

26th day of October, 2012, the follo-
wing described property as set forth in
said Final Judgment, to wit:
LOTS 10396 & 10397, SOUTH
VENICE, UNIT NO. 39, AC-
CORDING TO THE PLAT
THEREOF AS RECORDED IN
PLAT BOOK 6, PAGE 95, OF THE
PUBLIC RECORDS OF SARA-
SOTA COUNTY, FLORIDA.

ANY PERSON CLAIMING AN INTER-
EST IN THE SURPLUS FROM
THE SALE, IF ANY, OTHER THAN
THE PROPERTY OWNER AS OF
THE DATE OF THE LIS PENDENS
MUST FILE A CLAIM WITHIN 60
DAYS AFTER THE SALE.

In accordance with the Americans
With Disabilities Act, persons need-
ing a reasonable accommodation to
participate in this proceeding should
contact the Clerk of the Circuit Court
no later than seven business days prior
to the proceeding at the Sarasota County
Courthouse. Telephone 941-861-7425
(Sarasota and Venice) or 1-800-955-
8770 via Florida Relay Service.

Dated this 01 day of October, 2012.

By: Wendy Manswell, Esq.
Bar Number: 12027

and other persons having claims or de-
mands against decedent's estate must
file their claims with this court WITH-
IN 3 MONTHS AFTER THE DATE
OF THE FIRST PUBLICATION OF
THIS NOTICE.

ALL CLAIMS NOT FILED WITH-
IN THE TIME PERIODS SET FORTH
IN SECTION 733.702 OF THE FLOR-
IDA PROBATE CODE WILL BE FOR-
EVER BARRED.

NOTWITHSTANDING THE
TIME PERIOD SET FORTH
ABOVE, ANY CLAIM FILED TWO
(2) YEARS OR MORE AFTER THE
DECEDENT'S DATE OF DEATH IS
BARRED.

The date of first publication of this
notice is: October 5th, 2012.

H. GREG LEE,
Personal Representative
2014 Fourth Street
Sarasota, Florida 34237

H. Greg Lee
Attorney for Personal Representative
Florida Bar No. 351301
H. GREG LEE, P.A.
2014 Fourth Street
Sarasota, FL 34237
Telephone: (941) 954-0067
Facsimile: (941) 365-1492
October 5, 12, 2012 12-3838S

SECOND INSERTION

NOTICE OF ACTION
IN THE CIRCUIT COURT IN
AND FOR SARASOTA COUNTY,
FLORIDA -
CIVIL ACTION

Case #. 2012 CA 007291 NC
CITY OF SARASOTA, FLORIDA,
a municipal corporation,
Plaintiff, v.

JACQUELINE R. LAMPKIN;
CAROLINE WHEELER;
CURTIS ROBINSON; CLYDE
ROBINSON, JR.; AND THE
UNKNOWN SPOUSE, HEIRS,
DEVISEES, GRANTEEES,
CREDITORS OR OTHER PARTIES
CLAIMING BY, THROUGH,
UNDER OR AGAINST DOROTHY
SIMS A/K/A DOROTHY
MITCHELL, WHO IS KNOWN TO
BE DEAD,
Defendants.

TO: Unknown spouse, heirs, devisees,
grantees, creditors, or other parties
claiming by, through, under or against
Dorothy Sims a/k/a Dorothy Mitchell,
who is known to be dead

The natural Defendants are Jacque-
line R. Lampkin; Caroline Wheeler;
Curtis Robinson, and Clyde Robinson,
Jr. There are no corporate Defendants.
The unknown Defendants in this ac-
tion are:

Unknown spouse, heirs, devisees,
grantees, creditors, or other parties
claiming by, through, under or against
Dorothy Sims a/k/a Dorothy Mitchell,
who is known to be dead

A Complaint has been filed to fore-
close to mortgage liens against certain
real property in Sarasota County, Flori-
da. The Complaint has been filed in
the Circuit Court of the Twelfth Judi-
cial Circuit in and for Sarasota County,
Florida. The action is styled City of
Sarasota, Florida versus Jacqueline R.

Lampkin, et al.
The real property which Plaintiff,
City of Sarasota, Florida seeks to fore-
close is the following:
Lot 10, Block 5, Southside Ad-
dition to Newtown, according
to the map or plat thereof as
recorded in Plat Book 1, Page
30, Public Records of Sarasota
County, Florida.

This is Parcel ID No. 2024-
07-0054 located at 1658 22nd
Street, Sarasota, FL 34234.

Each Defendant is required to serve
written defenses to the Complaint
on Plaintiff's attorney Michael A.
Connolly at Fournier, Connolly, War-
ren & Shamsey, P.A., 1 South School
Avenue, Suite 700, Sarasota, Florida
34237 on or before the 05 day of No-
vember, 2012; and to file the origi-
nal of the defense with the Clerk of
Circuit Court either before service on
the Plaintiff's attorney or immediately
thereafter, showing what right, title,
interest or lien the Defendant has in
or to the property described above. If
any Defendant fails to do so, a default
will be entered against that Defendant
for the relief demanded in the Com-
plaint.

WITNESS my hand and the seal of
this Court on this 24 day of September,
2012.

KAREN E. RUSHING
Clerk of Circuit Court
(SEAL) By: Colin Overholt
Deputy Clerk

Plaintiff's Attorney
MICHAEL A. CONNOLLY
FOURNIER, CONNOLLY,
WARREN & SHAMSEY, P.A.
1 South School Avenue, Suite 700
Sarasota, Florida 34237
October 5, 12, 2012 12-3803S

SECOND INSERTION

NOTICE OF SALE
IN THE CIRCUIT COURT OF THE
TWELFTH JUDICIAL CIRCUIT
IN AND FOR SARASOTA COUNTY,
FLORIDA

CASE NO.: 2012-CA-4578 NC
SARASOTA FLEX SPACE
WAREHOUSING, LLC,
Plaintiff, v.
JAMES C. DION, LLC;
SARASOTA BUSINESS
CENTER II CONDOMINIUM;
and SARASOTA BUSINESS
CENTER II CONDOMINIUM
ASSOCIATION INC.
Defendants.

NOTICE IS HEREBY GIVEN that pursuant to a Uniform Final Judgment of Mortgage Foreclosure dated the 25th day of September, 2012 and entered in Civil Action Number: 2012-CA-4578 in the Circuit Court of the Twelfth Judicial Circuit, in and for Sarasota County, Florida, wherein SARASOTA FLEX SPACE WAREHOUSING, LLC is the Plaintiff, and JAMES C. DION, LLC is the Defendant, I, Karen E. Rushing, Clerk of the above-entitled Court, will sell to the highest and best bidder, or bidders, for cash, on the 29th day of October, 2012, at 9:00 a.m., except as set forth herein, at www.sarasota.realforeclose.com, the real and personal property described as follows as set forth in said Uniform Final Judgment of Mortgage Foreclosure situated in Sarasota County, Florida:

Unit 12, Building E, SARASOTA BUSINESS CENTER II, a Condominium, according to the Declaration of Condominium recorded in the Official Records as Instrument #2005104096, as amended, and as per plat thereof recorded in Condominium Book 37, Page 44, Public Records of Sarasota County, Florida.

ANY PERSON CLAIMING AN INTEREST IN THE SURPLUS FROM THE SALE, IF ANY, OTHER THAN THE PROPERTY OWNER AS OF THE DATE OF THE LIS PENDENS, MUST FILE A CLAIM WITHIN 60 DAYS AFTER THE SALE.

Dated this 2 day of October, 2012.

FRED E. MOORE, ESQUIRE
FBN: 273480
Primary Email:
fmoore@blalockwalters.com
Secondary Email:
eservice@blalockwalters.com
MARISA J. DAVIES, ESQUIRE
FBN: 795771
Primary Email:
mdavies@blalockwalters.com
Secondary Email:
eservice@blalockwalters.com
BLALOCK WALTERS, P.A.
802 11th Street West
Bradenton, Florida 34205
Telephone: 941.748.0100
Facsimile: 941.745.2093
Attorneys for Plaintiff.
589563/1
October 5, 12, 2012 12-3816S

SECOND INSERTION

NOTICE OF FORECLOSURE SALE
IN THE CIRCUIT COURT OF THE
12TH JUDICIAL CIRCUIT, IN
AND FOR SARASOTA COUNTY,
FLORIDA

CIVIL DIVISION:
CASE NO.: 2012 CA 000635 NC
BANK OF AMERICA, N.A.,
Plaintiff, vs.
SUSAN L. WEBER; RYAN
MCCRACKEN,
Defendant(s).

NOTICE IS HEREBY GIVEN pursuant to Final Judgment of Foreclosure dated the 18th day of September, 2012, and entered in Case No. 2012 CA 000635 NC, of the Circuit Court of the 12TH Judicial Circuit in and for Sarasota County, Florida, wherein BANK OF AMERICA, N.A. is the Plaintiff and SUSAN L. WEBER; RYAN MCCRACKEN; UNKNOWN TENANT(S) IN POSSESSION OF THE SUBJECT PROPERTY are defendants. The Clerk of this Court shall sell to the highest and best bidder for cash electronically at www.sarasota.realforeclose.com at 9:00 AM on the 26th day of October, 2012, the following described property as set forth in said Final Judgment, to wit:

LOT 11, BLOCK 1781, THIRTY-FOURTH ADDITION TO PORT CHARLOTTE SUBDIVISION, A SUBDIVISION, ACCORDING TO THE MAP OR PLAT THEREOF AS RECORDED IN PLAT BOOK 15, PAGE 18, PUBLIC RECORDS OF SARASOTA COUNTY, FLORIDA

ANY PERSON CLAIMING AN INTEREST IN THE SURPLUS FROM THE SALE, IF ANY, OTHER THAN THE PROPERTY OWNER AS OF THE DATE OF THE LIS PENDENS MUST FILE A CLAIM WITHIN 60 DAYS AFTER THE SALE.

In accordance with the Americans With Disabilities Act, persons needing a reasonable accommodation to participate in this proceeding should contact the Clerk of the Circuit Court no later than seven business days prior to the proceeding at the Sarasota County Courthouse. Telephone 941-861-7425 (Sarasota and Venice) or 1-800-955-8770 via Florida Relay Service.

Dated this 01 day of October, 2012.

By: Marjorie Levine, Esq.
Bar Number: 96413
Submitted by:
LAW OFFICES OF
MARSHALL C. WATSON, P.A.
1800 NW 49th Street, Suite 120
Fort Lauderdale, Florida 33309
Telephone: (954) 453-0365
Facsimile: (954) 771-6052
Toll Free: 1-800-441-2438
DESIGNATED PRIMARY E-MAIL
FOR SERVICE PURSUANT TO FLA.
R. JUD. ADMIN 2.516
eservice@marshallwatson.com
11-09213
October 5, 12, 2012 12-3826S

SECOND INSERTION

NOTICE OF SALE
IN THE CIRCUIT COURT OF THE
TWELFTH JUDICIAL CIRCUIT
IN AND FOR SARASOTA COUNTY,
FLORIDA

CIVIL DIVISION
Case #: 2008-CA-016805-NC
DIVISION: A

BAC Home Loans Servicing, L.P.
f/k/a Countrywide Home Loans
Servicing, L.P.
Plaintiff, vs.-
Sandra L. Benson; Kimberly Stanfel;
Mortgage Electronic Registration
Systems, Inc. as Nominee for
Quicken Loans, Inc.
Defendant(s).

NOTICE IS HEREBY GIVEN pursuant to an Order of Final Judgment of Foreclosure dated September 24, 2012, entered in Civil Case No. 2008-CA-016805-NC of the Circuit Court of the 12th Judicial Circuit in and for Sarasota County, Florida, wherein BAC Home Loans Servicing, L.P. f/k/a Countrywide Home Loans Servicing, L.P., Plaintiff and Sandra L. Benson and Kimberly Stanfel are defendant(s), I, will sell to the highest and best bidder for cash VIA THE INTERNET AT WWW.SARASOTA.REALFORECLOSE.COM , AT 9:00 A.M. on October 29, 2012, the following described property as set forth in said Final Judgment, to-wit:

LOT 1446, SARASOTA SPRINGS, UNIT NO. 12, ACCORDING TO THE PLAT THEREOF, RECORDED IN PLAT BOOK 8, PAGE 42, OF THE PUBLIC RECORDS OF SARASOTA COUNTY, FLORIDA.

ANY PERSON CLAIMING AN INTEREST IN THE SURPLUS FROM THE SALE, IF ANY, OTHER THAN THE PROPERTY OWNER AS OF THE DATE OF THE LIS PENDENS MUST FILE A CLAIM WITHIN 60 DAYS AFTER THE SALE.

In accordance with the Americans With Disabilities Act, persons needing a reasonable accommodation to participate in this proceeding should contact the Clerk of the Circuit Court no later than seven business days prior to the proceeding at the Sarasota County Courthouse. Telephone 941-861-7425 (Sarasota and Venice) or 1-800-955-8770 via Florida Relay Service.

By: Ella Roberts, Esquire
FL Bar # 75943
SHAPIRO, FISHMAN &
GACHÉ, LLP
Attorneys for Plaintiff
2424 North Federal Highway,
Suite 360
Boca Raton, Florida 33431
Telephone: (561) 998-6700
Fax: (561) 998-6707
10-169144 FCO1 CWF
October 5, 12, 2012 12-3850S

SECOND INSERTION

NOTICE OF SALE
IN THE CIRCUIT COURT OF THE
TWELFTH JUDICIAL CIRCUIT
IN AND FOR SARASOTA COUNTY,
FLORIDA

CIVIL DIVISION
Case #: 2010-CA-009276-NC
DIVISION: A

Federal National Mortgage
Association
Plaintiff, vs.-
Thanh Thi Vo a/k/a Thanh T. Vo and
Ca T. Thai, Wife and Husband; Bank
of America, National Association;
Fidelity Bank f/k/a Fidelity National
Bank; Grove Pointe Homeowners
Association, Inc.;
Defendant(s).

NOTICE IS HEREBY GIVEN pursuant to an Order of Final Judgment of Foreclosure dated September 18, 2012, entered in Civil Case No. 2010-CA-009276-NC of the Circuit Court of the 12th Judicial Circuit in and for Sarasota County, Florida, wherein Federal National Mortgage Association, Plaintiff and Thanh Thi Vo a/k/a Thanh T. Vo and Ca T. Thai, Wife and Husband are defendant(s), I, will sell to the highest and best bidder for cash VIA THE INTERNET AT WWW.SARASOTA.REALFORECLOSE.COM , AT 9:00 A.M. on November 2, 2012, the following described property as set forth in said Final Judgment, to-wit:

LOT 257, GROVE POINTE, UNIT 1, ACCORDING TO THE PLAT THEREOF, AS RECORDED IN PLAT BOOK 34, PAGE 1, OF THE PUBLIC RECORDS OF SARASOTA COUNTY, FLORIDA.

ANY PERSON CLAIMING AN INTEREST IN THE SURPLUS FROM THE SALE, IF ANY, OTHER THAN THE PROPERTY OWNER AS OF THE DATE OF THE LIS PENDENS MUST FILE A CLAIM WITHIN 60 DAYS AFTER THE SALE.

In accordance with the Americans With Disabilities Act, persons needing a reasonable accommodation to participate in this proceeding should contact the Clerk of the Circuit Court no later than seven business days prior to the proceeding at the Sarasota County Courthouse. Telephone 941-861-7425 (Sarasota and Venice) or 1-800-955-8770 via Florida Relay Service.

By: Ella Roberts, Esquire
FL Bar # 75943
SHAPIRO, FISHMAN &
GACHÉ, LLP
Attorneys for Plaintiff
2424 North Federal Highway,
Suite 360
Boca Raton, Florida 33431
Telephone: (561) 998-6700
Fax: (561) 998-6707
10-184283 FCO1 WCC
October 5, 12, 2012 12-3852S

SECOND INSERTION

NOTICE OF SALE
IN THE CIRCUIT COURT OF THE
TWELFTH JUDICIAL CIRCUIT
IN AND FOR SARASOTA COUNTY,
FLORIDA

CIVIL DIVISION
Case #: 2009-CA-002012-NC
DIVISION: A

Litton Loan Servicing, LP
Plaintiff, vs.-
Michelle R. Johnson; Unknown
Parties in Possession #1; If living,
and all Unknown Parties claiming
by, through, under and against the
above named Defendant(s) who
are not known to be dead or alive,
whether said Unknown Parties
may claim an interest as Spouse,
Heirs, devisees, grantees, or Other
Claimants
Defendant(s).

NOTICE IS HEREBY GIVEN pursuant to an Order of Final Judgment of Foreclosure dated September 24, 2012, entered in Civil Case No. 2009-CA-002012-NC of the Circuit Court of the 12th Judicial Circuit in and for Sarasota County, Florida, wherein Green Tree Servicing LLC, Plaintiff and Michelle R. Johnson are defendant(s), I, will sell to the highest and best bidder for cash VIA THE INTERNET AT WWW.SARASOTA.REALFORECLOSE.COM , AT 9:00 A.M. on October 29, 2012, the following described property as set forth in said Final Judgment, to-wit:

LOT 15, BLOCK 213 OF EDGEWOOD SECTION OF VENICE, ACCORDING TO THE PLAT THEREOF, AS RECORDED IN PLAT BOOK 2, PAGE 166, OF THE PUBLIC RECORDS OF SARASOTA COUNTY, FLORIDA.

ANY PERSON CLAIMING AN INTEREST IN THE SURPLUS FROM THE SALE, IF ANY, OTHER THAN THE PROPERTY OWNER AS OF THE DATE OF THE LIS PENDENS MUST FILE A CLAIM WITHIN 60 DAYS AFTER THE SALE.

In accordance with the Americans With Disabilities Act, persons needing a reasonable accommodation to participate in this proceeding should contact the Clerk of the Circuit Court no later than seven business days prior to the proceeding at the Sarasota County Courthouse. Telephone 941-861-7425 (Sarasota and Venice) or 1-800-955-8770 via Florida Relay Service.

By: Ella Roberts, Esquire
FL Bar # 75943
SHAPIRO, FISHMAN &
GACHÉ, LLP
Attorneys for Plaintiff
2424 North Federal Highway,
Suite 360
Boca Raton, Florida 33431
Telephone: (561) 998-6700
Fax: (561) 998-6707
09-125641 FCO1 GRT
October 5, 12, 2012 12-3853S

SECOND INSERTION

NOTICE OF FORECLOSURE SALE
IN THE CIRCUIT COURT OF THE
TWELFTH JUDICIAL CIRCUIT
IN AND FOR SARASOTA COUNTY,
FLORIDA

CIVIL ACTION
CASE NO.: 2010-CA-004053-NC
DIVISION: A

CHASE HOME FINANCE LLC
SUCCESSOR BY MERGER
TO CHASE MANHATTAN
MORTGAGE CORPORATION,
Plaintiff, vs.
LEONARD J. MILAZZO , et al,
Defendant(s).

NOTICE IS HEREBY GIVEN pursuant to a Final Judgment of Mortgage Foreclosure dated September 18, 2012 and entered in Case No. 2010-CA-004053-NC of the Circuit Court of the Twelfth Judicial Circuit in and for SARASOTA County, Florida wherein JPMORGAN CHASE BANK, NATIONAL ASSOCIATION, SUCCESSOR BY MERGER TO CHASE HOME FINANCE LLC 1, is the Plaintiff and LEONARD J. MILAZZO; THE UNKNOWN SPOUSE OF LEONARD J. MILAZZO N/K/A ANNA MILAZZO; CHASE BANK USA, NATIONAL ASSOCIATION SUCCESSOR BY MERGER TO CHASE MANHATTAN BANK USA, N.A.; GROVE POINTE HOMEOWNERS ASSOCIATION, INC.; are the Defendants. The Clerk will sell to the highest and best bidder for cash at WWW.SARASOTA.REALFORECLOSE.COM at 9:00AM, on the 23rd day of October, 2012, the following described property as set forth in said Final Judgment:

LOT 150, GROVE POINTE SUBDIVISION, UNIT 1, AS PER PLAT THEREOF, RECORDED IN PLAT BOOK 34, PAGE 1, PUBLIC RECORDS OF SARASOTA COUNTY, FLORIDA.

A/K/A 4857 POST POINTE DRIVE, SARASOTA, FL 34233
Any person claiming an interest in the surplus from the sale, if any, other than the property owner as of the date of the Lis Pendens must file a claim within sixty (60) days after the sale.

In accordance with the Americans With Disabilities Act, persons needing a reasonable accommodation to participate in this proceeding should contact the Clerk of the Circuit Court no later than seven business days prior to the proceeding at the Sarasota County Courthouse. Telephone 941-861-7425 (Sarasota and Venice) or 1-800-955-8770 via Florida Relay Service.

By: Matthew Marks
Florida Bar No. 524336
RONALD R. WOLFE
& ASSOCIATES, P.L.
P.O. Box 25018
Tampa, Florida 33622-5018
(813) 251-4766
F10023072
October 5, 12, 2012 12-3856S

SECOND INSERTION

NOTICE OF ACTION
IN THE CIRCUIT COURT IN
AND FOR SARASOTA COUNTY,
FLORIDA

CASE NO.: 2012 CA 001646 NC
WELLS FARGO BANK, NA
Plaintiff, vs.

BERNARD C. SCHIEFER A/K/A
BERNARD SCHIEFER; WESLEY
S. CALDWELL, III (DECEASED);
UNKNOWN TENANT I;
UNKNOWN TENANT II;
UNKNOWN SPOUSE OF
BERNARD C. SCHIEFER A/K/A
BERNARD SCHIEFER; PNC
BANK, NATIONAL
ASSOCIATION; JANYS R.
DILLENBACK-CALDWELL
INDIVIDUALLY AND AS
EXECUTRIX AND AS TRUSTEE
OF THE ASHLEY CALDWELL &
FERRIS CALDWELL TRUST;
THERESA CALDWELL AS
TRUSTEE OF THE ASHLEY
CALDWELL & FERRIS
CALDWELL TRUST II; UNITED
STATES OF AMERICA,
DEPARTMENT OF TREASURY -
INTERNAL REVENUE SERVICE;
ANY UNKNOWN HEIRS,
DEVISEES, GRANTEES,
ASSIGNEES, LIENORS,
CREDITORS, TRUSTEES,
AND OTHER UNKNOWN PERSONS
OR UNKNOWN SPOUSES
CLAIMING BY, THROUGH AND
UNDER ANY OF THE
ABOVE-NAMED DEFENDANTS,
and any unknown heirs, devisees,
grantees, creditors, and other
unknown persons or unknown
spouses claiming by, through
and under any of the above-named
Defendants,
Defendants.

TO:
ANY UNKNOWN HEIRS, DEVI-
SEES, GRANTEES, ASSIGNEES,
LIENORS, CREDITORS, TRUSTEES,
AND OTHER UNKNOWN PERSONS
OR UNKNOWN SPOUSES CLAIM-
ING BY, THROUGH AND UNDER
ANY OF THE ABOVE-NAMED DE-
FENDANTS

LAST KNOWN ADDRESS STATED,
CURRENT RESIDENCE UNKNOWN

And any unknown heirs, devisees,
grantees, creditors and other unknown
persons or unknown spouses claim-
ing by, through and under the above-
named Defendant(s), if deceased or
whose last known addresses are un-
known.

YOU ARE HEREBY NOTIFIED
that an action to foreclose Mortgage
covering the following real and personal
property described as follows, to-wit:
LOT 1, BLOCK 444, 9TH ADD
TO PORT CHARLOTTE SUB-
DIVISION, A SUBDIVISION,
ACCORDING TO THE PLAT
THEREOF, AS RECORDED
IN PLAT BOOK 12, PAGES
21, 21A-21S, OF THE PUBLIC
RECORDS OF SARASOTA
COUNTY, FLORIDA.

has been filed against you and you
are required to serve a copy of your
written defenses, if any, to it on Mark
William Hernandez, Butler & Hosch,
P.A., 3185 South Conway Road, Suite
E, Orlando, Florida 32812 and file the
original with the Clerk of the above-
entitled Court on or before 30 days
from the first publication, otherwise
a Judgment may be entered against
you for the relief demanded in the
Complaint.

In accordance with the Americans
With Disabilities Act, persons need-
ing a reasonable accommodation to
participate in this proceeding should
contact the Clerk of the Circuit
Court no later than seven business
days prior to the proceeding at the
Sarasota County Courthouse. Tele-
phone 941-861-7425 (Sarasota and
Venice) or 1-800-955-8770 via Flori-
da Relay Service.

WITNESS my hand and seal of said
Court on the 28 day of September,
2012.

KAREN E. RUSHING, CLERK
CLERK OF THE CIRCUIT COURT
(COURT SEAL) By: M. Foulks
Deputy Clerk

BUTLER & HOSCH, P.A.
3185 South Conway Road, Suite E
Orlando, Florida 32812
Telephone: (407) 381-5200
Fax: (407) 381-5577
B&H # 309904
October 5, 12, 2012 12-3818S

SECOND INSERTION

NOTICE OF FORECLOSURE SALE
IN THE CIRCUIT COURT OF THE
12TH JUDICIAL CIRCUIT, IN
AND FOR SARASOTA COUNTY,
FLORIDA

CIVIL DIVISION:
CASE NO.: 58-2010-CA-009863 NC
THE BANK OF NEW YORK
MELLON FKA THE BANK OF
NEW YORK, AS TRUSTEE FOR
THE CERTIFICATEHOLDERS
CWALT, INC., ALTERNATIVE
LOAN TRUST 2006-OA21,
MORTGAGE PASS-THROUGH
CERTIFICATES, SERIES 2006-
OA21,
Plaintiff, vs.

JUAN AGOSTO A/K/A JUAN
R. AGOSTO; MORTGAGE
ELECTRONIC REGISTRATION
SYSTEMS, INCORPORATED, AS
NOMINEE FOR FIRST MAGNUS
FINANCIAL CORPORATION;
PALMER RANCH MASTER
PROPERTY OWNERS
ASSOCIATION, INC.; STATE
OF FLORIDA DEPARTMENT
OF REVENUE; TURTLE ROCK
COMMUNITY ASSOCIATION,
INC.; UNKNOWN SPOUSE OF
JUAN AGOSTO A/K/A JUAN R.
AGOSTO; UNKNOWN TENANT
(S); IN POSSESSION OF THE
SUBJECT PROPERTY,
Defendant(s).

NOTICE IS HEREBY GIVEN pursuant to Final Judgment of Foreclosure dated the 18th day of September 2012 and entered in Case No. 58-2010-CA-009863 NC, of the Circuit Court of the 12TH Judicial Circuit in and for Sarasota County, Florida, wherein THE BANK OF NEW YORK MELLON FKA THE BANK OF NEW YORK, AS TRUSTEE FOR THE CERTIFICATEHOLDERS CWALT, INC., ALTERNATIVE LOAN TRUST 2006-OA21, MORTGAGE PASS-THROUGH CERTIFICATES, SERIES 2006-OA21 is the Plaintiff and JUAN AGOSTO A/K/A JUAN R. AGOSTO, MORTGAGE ELECTRONIC REGISTRATION SYSTEMS, INCORPORATED, AS NOMINEE FOR FIRST MAGNUS FINANCIAL CORPORATION, PALMER RANCH MASTER PROPERTY OWNERS ASSOCIATION, INC., STATE OF FLORIDA

DEPARTMENT OF REVENUE, TUR-
TLE ROCK COMMUNITY ASSOCIA-
TION, INC., UNKNOWN SPOUSE
OF JUAN AGOSTO A/K/A JUAN R.
AGOSTO N/K/A JUAN R. AGOSTO
AND UNKNOWN TENANT(S) IN
POSSESSION OF THE SUBJECT
PROPERTY are defendants. The Clerk
of this Court shall sell to the highest
and best bidder for cash electronically
at www.sarasota.realforeclose.com at,
9:00 AM on the 23rd day of October
2012 the following described property
as set forth in said Final Judgment, to
wit:

LOT 24, PARCEL D, TURTLE
ROCK, UNIT 2, AS PER PLAT
THEREOF RECORDED IN
PLAT BOOK 37, PAGES 26, 26A
THROUGH 26E, PUBLIC RE-
CORDS OF SARASOTA COUN-
TY, FLORIDA.

ANY PERSON CLAIMING AN INTEREST IN THE SURPLUS FROM THE SALE, IF ANY, OTHER THAN THE PROPERTY OWNER AS OF THE DATE OF THE LIS PENDENS MUST FILE A CLAIM WITHIN 60 DAYS AFTER THE SALE.

In accordance with the Americans
With Disabilities Act, persons need-
ing a reasonable accommodation to
participate in this proceeding should
contact the Clerk of the Circuit Court
no later than seven business days
prior to the proceeding at the Sarasota
County Courthouse. Telephone 941-861-7425
(Sarasota and Venice) or 1-800-955-
8770 via Florida Relay Service.

Dated this 28 day of September,
2012.

Marjorie Levine, Esq.
Bar Number: 96413
Submitted by:
LAW OFFICES OF
MARSHALL C. WATSON, P.A.
1800 NW 49th Street, Suite 120
Fort Lauderdale, Florida 33309
Telephone: (954) 453-0365
Facsimile: (954) 771-6052
Toll Free: 1-800-441-2438
DESIGNATED PRIMARY E-MAIL
FOR SERVICE PURSUANT TO FLA.
R. JUD. ADMIN 2.516
eservice@marshallwatson.com
10-40260
October 5, 12, 2012 12-3806S

SECOND INSERTION

NOTICE OF FORECLOSURE SALE
IN THE CIRCUIT COURT OF THE
12TH JUDICIAL CIRCUIT, IN
AND FOR SARASOTA COUNTY,
FLORIDA

CIVIL DIVISION:
CASE NO.: 2009 CA 005026 NC
DEUTSCHE BANK NATIONAL
TRUST COMPANY AS
TRUSTEE FOR HSI
ASSET SECURITIZATION
CORPORATION 2005-NC2
MORTGAGE PASS-THROUGH
CERTIFICATES, SERIES
2005-NC2,
Plaintiff, vs.

HUNG MINH NGUYEN;
NEW CENTURY MORTGAGE
CORPORATION; MAI TRUC
NGUYEN; UNKNOWN TENANT
(S) IN POSSESSION OF THE
SUBJECT PROPERTY,
Defendant(s).

NOTICE IS HEREBY GIVEN pursuant to Final Judgment of Foreclosure dated the 18th day of September 2012 and entered in Case No. 2009 CA 005026 NC, of the Circuit Court of the 12TH Judicial Circuit in and for Sarasota County, Florida, wherein DEUTSCHE BANK NATIONAL TRUST COMPANY AS TRUSTEE FOR HSI ASSET SECURITIZATION CORPORATION 2005-NC2 MORTGAGE PASS-THROUGH CERTIFICATES, SERIES 2005-NC2 is the Plaintiff and HUNG MINH NGUYEN, NEW CENTURY MORTGAGE CORPORATION, MAI TRUC NGUYEN and UNKNOWN TENANT (S) IN POSSESSION OF THE SUBJECT PROPERTY are defendants. The Clerk of this Court shall sell to the highest and best bidder for cash electronically at www.sarasota.realforeclose.com at 9:00 AM on the 25th day of October 2012 the following described property as set forth in said Final Judgment, to-wit:

SEE ATTACHED EXHIBIT "A"
EXHIBIT "A"
BEGIN AT THE SW CORNER
OF TRACT 6, BLOCK 3, SEC-
TION 2, TOWNSHIP 37 SOUTH,
RANGE 18 EAST, AS PER PLAT
OF BEE RIDGE FARMS SUBDI-
VISION, ACCORDING TO THE
PLAT THEREOF, RECORDED
IN PLAT BOOK A, PAGE 40,

OF THE PUBLIC RECORDS OF
SARASOTA COUNTY, FLOR-
IDA. SAID POINT BEING ON
THE EAST RIGHT OF WAY OF
MCINTOSH ROAD (WIDTH
48 FEET); THENCE NORTH
ALONG THE EAST RIGHT OF
WAY OF MCINTOSH ROAD,
170 FEET FOR A POINT OF
BEGINNING; THENCE EAST
261 FEET; THENCE NORTH
100 FEET; THENCE WEST 261
FEET TO THE EAST RIGHT OF
WAY OF MCINTOSH ROAD;
THENCE SOUTH ALONG THE
EAST RIGHT OF WAY OF MC-
INTOSH ROAD; 100 FEET TO
THE POINT OF BEGINNING.
LYING AND BEING IN SEC-
TION 2, TOWNSHIP 37 SOUTH,
RANGE 18 EAST, SARASOTA
COUNTY, FLORIDA; LESS THE
WEST 18.0 FEET THEREOF.

ANY PERSON CLAIMING AN INTEREST IN THE SURPLUS FROM THE SALE, IF ANY, OTHER THAN THE PROPERTY OWNER AS OF THE DATE OF THE LIS PENDENS MUST FILE A CLAIM WITHIN 60 DAYS AFTER THE SALE.

In accordance with the Americans With
Disabilities Act, persons needing a reason-
able accommodation to participate in this
proceeding should contact the Clerk of the
Circuit Court no later than seven business
days prior to the proceeding at the Sarasota
County Courthouse. Telephone 941-861-
7425 (Sarasota and Venice) or 1-800-955-
8770 via Florida Relay Service.

Dated this 29 day of September,
2012.

Nicole J. Saviano, Esq.
Bar Number: 73162
Submitted by:
LAW OFFICES OF
MARSHALL C. WATSON, P.A.
1800 NW 49th Street, Suite 120
Fort Lauderdale, Florida 33309
Telephone: (954) 453-0365
Facsimile: (954) 771-6052
Toll Free: 1-800-441-2438
DESIGNATED PRIMARY E-MAIL
FOR SERVICE PURSUANT TO FLA.
R. JUD. ADMIN 2.516
eservice@marshallwatson.com
09-17833
October 5, 12, 2012 12-3814S

SECOND INSERTION

NOTICE OF FORECLOSURE SALE IN THE CIRCUIT COURT OF THE 12TH JUDICIAL CIRCUIT, IN AND FOR SARASOTA COUNTY, FLORIDA

CIVIL DIVISION:
CASE NO.: 2008 CA 007126 NC
CHASE HOME FINANCE LLC,
Plaintiff, vs.

NADINE S. RALEY; ROBERT L. RALEY; UNKNOWN SPOUSE OF NADINE S. RALEY; JOHN DOE; JANE DOE AS UNKNOWN TENANT (S) IN POSSESSION OF THE SUBJECT PROPERTY,
Defendant(s).

NOTICE IS HEREBY GIVEN pursuant to Final Judgment of Foreclosure dated the 18th day of September 2012 and entered in Case No. 2008 CA 007126 NC, of the Circuit Court of the 12TH Judicial Circuit in and for Sarasota County, Florida, wherein CHASE HOME FINANCE LLC is the Plaintiff and NADINE S. RALEY, LONGWOOD RUN COMMUNITY ASSOCIATION, INC, JANE DOE, JOHN DOE, LONGWOOD VILLAS OF SARASOTA HOMEOWNERS ASSOCIATION, INC., ROBERT L. RALEY and UNKNOWN SPOUSE OF NADINE S. RALEY IN POSSESSION OF THE SUBJECT PROPERTY are defendants. The Clerk of this Court shall sell to the highest and best bidder for cash electronically at www.sarasota.realforeclose.com at, 9:00 AM on the 23rd day of October 2012 the following described property as set forth in said Final Judgment, to wit:

LOT 4, LONGWOOD VILLAS, UNIT ONE, AS PER PLAT THEREOF RECORDED IN PLAT BOOK 30, PAGE (S) 29 AND 29A, OF THE PUBLIC RECORDS OF SARASOTA COUNTY, FLORIDA.

ANY PERSON CLAIMING AN INTEREST IN THE SURPLUS FROM THE SALE, IF ANY, OTHER THAN THE PROPERTY OWNER AS OF THE DATE OF THE LIS PENDENS MUST FILE A CLAIM WITHIN 60 DAYS AFTER THE SALE.

In accordance with the Americans With Disabilities Act, persons needing a reasonable accommodation to participate in this proceeding should contact the Clerk of the Circuit Court no later than seven business days prior to the proceeding at the Sarasota County Courthouse. Telephone 941-861-7425 (Sarasota and Venice) or 1-800-955-8770 via Florida Relay Service.

Dated this 28th day of September, 2012.

By: Jimmy Edwards, Esq.
Bar Number: 81855

Submitted by:
LAW OFFICES OF
MARSHALL C. WATSON, P.A.
1800 NW 49th Street, Suite 120
Fort Lauderdale, Florida 33309
Telephone: (954) 453-0365
Facsimile: (954) 771-6052
Toll Free: 1-800-441-2438
DESIGNATED PRIMARY E-MAIL
FOR SERVICE PURSUANT TO FLA.
R. JUD. ADMIN 2.516
eservice@marshallwatson.com
08-22627
October 5, 12, 2012 12-3781S

SECOND INSERTION

NOTICE OF SALE IN THE CIRCUIT COURT OF THE TWELFTH JUDICIAL CIRCUIT IN AND FOR SARASOTA COUNTY, FLORIDA

CASE NO. 2011 CA 000848 NC
US BANK NATIONAL
ASSOCIATION, AS TRUSTEE
FOR CMLTI 2007-10
Plaintiff, v.

J. BERNADETTE DEMARK DURST; UNKNKOWN SPOUSE OF J. BERNADETTE DEMARK-DURST; UNKNOWN TENANT 1; UNKNOWN TENANT 2; AND ALL UNKNOWN PARTIES CLAIMING BY, THROUGH, UNDER OR AGAINST THE ABOVE NAMED DEFENDANT(S), WHO (IS/ARE) NOT KNOWN TO BE DEAD OR ALIVE, WHETHER SAID UNKNOWN PARTIES CLAIM AS HEIRS, DEVISEES, GRANTEES, ASSIGNEES, LIENORS, CREDITORS, TRUSTEES, SPOUSES, OR OTHER CLAIMANTS; FIRST STATE BANK; STEARNS BANK NATIONAL ASSOCIATION
Defendants.

Notice is hereby given that, pursuant to the Summary Final Judgment of Foreclosure entered on September 24, 2012, in this cause, in the Circuit Court of Sarasota County, Florida, the clerk shall sell the property situated in Sarasota County, Florida, described as:

LOT 39, LOMA LINDA PARK, ACCORDING TO THE PLAT THEREOF, RECORDED IN PLAT BOOK 5, PAGE 38, OF THE PUBLIC RECORDS OF SARASOTA COUNTY, FLORIDA.

a/k/a 2323 PROSPECT STREET, SARASOTA, FL 34239

at public sale, to the highest and best bidder, for cash, online at www.sarasota.realforeclose.com, Sarasota County, Florida, on October 31, 2012 at 09:00 AM.

Any person claiming an interest in the surplus from the sale, if any, other than the property owner as of the date of the lis pendens must file a claim within 60 days after the sale.

In accordance with the Americans With Disabilities Act, persons needing a reasonable accommodation to participate in this proceeding should contact the Clerk of the Circuit Court no later than seven business days prior to the proceeding at the Sarasota County Courthouse. Telephone 941-861-7425 (Sarasota and Venice) or 1-800-955-8770 via Florida Relay Service.

Dated at St. Petersburg, Florida, this 2 day of October, 2012.

Karen E. Rushing
Clerk of the Circuit Court
s\ Tara M. McDonald, Esquire
Tara M. McDonald, Esquire
Florida Bar No. 43941

DOUGLAS C. ZAHM, P.A.
12425 28th Street North, Suite 200
St. Petersburg, FL 33716
Telephone No. (727) 536-4911
Fax No. (727) 539-1094
Attorney for Plaintiff
885101330
October 5, 12, 2012 12-3866S

SECOND INSERTION

NOTICE OF SALE IN THE CIRCUIT COURT OF THE TWELFTH JUDICIAL CIRCUIT IN AND FOR SARASOTA COUNTY, FLORIDA

CASE NO. 2011 CA 007194 NC
WELLS FARGO BANK, N.A.
Plaintiff, v.

LAURIE L. CORBY; ROY A. CORBY; UNKNOWN TENANT 1; UNKNOWN TENANT 2; AND ALL UNKNOWN PARTIES CLAIMING BY, THROUGH, UNDER OR AGAINST THE ABOVE NAMED DEFENDANT(S), WHO (IS/ARE) NOT KNOWN TO BE DEAD OR ALIVE, WHETHER SAID UNKNOWN PARTIES CLAIM AS HEIRS, DEVISEES, GRANTEES, ASSIGNEES, LIENORS, CREDITORS, TRUSTEES, SPOUSES, OR OTHER CLAIMANTS; JOCKEY CLUB OF NORTH PORT PROPERTY OWNERS' ASSOCIATION, INC.
Defendants.

Notice is hereby given that, pursuant to the Summary Final Judgment of Foreclosure entered on September 24, 2012, in this cause, in the Circuit Court of Sarasota County, Florida, the clerk shall sell the property situated in Sarasota County, Florida, described as:

LOT 31, BLOCK 2623, 52ND ADDITION TO PORT CHARLOTTE SUBDIVISION, ACCORDING TO THE PLAT THEREOF, AS RECORDED IN PLAT BOOK 21, PAGES 13, 13A THROUGH 13NN, INCLUSIVE, OF THE PUBLIC RECORDS OF SARASOTA COUNTY, FLORIDA.

a/k/a 2685 PAN AMERICAN BLVD., NORTH PORT, FL 34287-1785

at public sale, to the highest and best bidder, for cash, online at www.sarasota.realforeclose.com, Sarasota County, Florida, on October 31, 2012 at 09:00 AM.

Any person claiming an interest in the surplus from the sale, if any, other than the property owner as of the date of the lis pendens must file a claim within 60 days after the sale.

In accordance with the Americans With Disabilities Act, persons needing a reasonable accommodation to participate in this proceeding should contact the Clerk of the Circuit Court no later than seven business days prior to the proceeding at the Sarasota County Courthouse. Telephone 941-861-7425 (Sarasota and Venice) or 1-800-955-8770 via Florida Relay Service.

Dated at St. Petersburg, Florida, this 2 day of October, 2012.

Karen E. Rushing
Clerk of the Circuit Court
s\ Tara M. McDonald, Esquire
Tara M. McDonald, Esquire
Florida Bar No. 43941

DOUGLAS C. ZAHM, P.A.
12425 28th Street North, Suite 200
St. Petersburg, FL 33716
Telephone No. (727) 536-4911
Fax No. (727) 539-1094
Attorney for Plaintiff
885101460
October 5, 12, 2012 12-3864S

SECOND INSERTION

NOTICE OF SALE IN THE CIRCUIT COURT OF THE TWELFTH JUDICIAL CIRCUIT IN AND FOR SARASOTA COUNTY, FLORIDA

CASE NO. 58-2011-CA-003589NC
MIDFIRST BANK
Plaintiff, v.

TREVOR HOLLINGER; ALLISON HINSHAW; UNKNOWN TENANT 1; UNKNOWN TENANT 2; AND ALL UNKNOWN PARTIES CLAIMING BY, THROUGH, UNDER OR AGAINST THE ABOVE NAMED DEFENDANT(S), WHO (IS/ARE) NOT KNOWN TO BE DEAD OR ALIVE, WHETHER SAID UNKNOWN PARTIES CLAIM AS HEIRS, DEVISEES, GRANTEES, ASSIGNEES, LIENORS, CREDITORS, TRUSTEES, SPOUSES, OR OTHER CLAIMANTS; VENICE GARDENS CIVIC ASSOCIATION, INC.
Defendants.

Notice is hereby given that, pursuant to the Summary Final Judgment of Foreclosure entered on September 04, 2012, and the Order Rescheduling Foreclosure Sale entered on September 27, 2012, in this cause, in the Circuit Court of Sarasota County, Florida, the clerk shall sell the property situated in Sarasota County, Florida, described as:

LOT 302, VENICE GARDENS SUBDIVISION, UNIT 5, A SUBDIVISION, ACCORDING TO THE PLAT THEREOF, AS RECORDED IN PLAT BOOK 9, PAGE 75, PUBLIC RECORDS OF SARASOTA COUNTY, FLORIDA.

a/k/a 1782 PALM DR., VENICE, FL 34293-2730

at public sale, to the highest and best bidder, for cash, online at www.sarasota.realforeclose.com, Sarasota County, Florida, on November 02, 2012 at 09:00 AM.

Any person claiming an interest in the surplus from the sale, if any, other than the property owner as of the date of the lis pendens must file a claim within 60 days after the sale.

In accordance with the Americans With Disabilities Act, persons needing a reasonable accommodation to participate in this proceeding should contact the Clerk of the Circuit Court no later than seven business days prior to the proceeding at the Sarasota County Courthouse. Telephone 941-861-7425 (Sarasota and Venice) or 1-800-955-8770 via Florida Relay Service.

Dated at St. Petersburg, Florida, this 2 day of October, 2012.

Karen E. Rushing
Clerk of the Circuit Court
s\ Tara M. McDonald, Esquire
Tara M. McDonald, Esquire
Florida Bar No. 43941

DOUGLAS C. ZAHM, P.A.
12425 28th Street North, Suite 200
St. Petersburg, FL 33716
Telephone No. (727) 536-4911
Fax No. (727) 539-1094
Attorney for Plaintiff
111110157
October 5, 12, 2012 12-3861S

SECOND INSERTION

NOTICE OF FORECLOSURE SALE IN THE CIRCUIT COURT OF THE 12TH JUDICIAL CIRCUIT, IN AND FOR SARASOTA COUNTY, FLORIDA

CIVIL DIVISION:
CASE NO.: 2009 CA 005699 NC
COUNTRYWIDE HOME LOANS
SERVICING LP,
Plaintiff, vs.

TERRY BRYAN ENGERT A/K/A TERRY B ENGERT; KELLY J KLOTS; TIMOTHY M KLOTS; UNKNOWN SPOUSE OF TERRY BRYAN ENGERT A/K/A TERRY B ENGERT; UNKNOWN TENANT (S) IN POSSESSION OF THE SUBJECT PROPERTY,
Defendant(s).

NOTICE IS HEREBY GIVEN pursuant to Final Judgment of Foreclosure dated the 18th day of September 2012 and entered in Case No. 2009 CA 005699 NC, of the Circuit Court of the 12TH Judicial Circuit in and for Sarasota County, Florida, wherein COUNTRYWIDE HOME LOANS SERVICING LP is the Plaintiff and TERRY BRYAN ENGERT A/K/A TERRY B. ENGERT, TIMOTHY M KLOTS, KELLY J KLOTS and UNKNOWN TENANT(S) IN POSSESSION OF THE SUBJECT PROPERTY are defendants. The Clerk of this Court shall sell to the highest and best bidder for cash electronically at www.sarasota.realforeclose.com at, 9:00 AM on the 25th day of October 2012, the following described property as set forth in said Final Judgment, to wit:

LOT 1654, LAKE SARASOTA, UNIT NO. 18, ACCORDING TO THE PLAT THEREOF RECORDED IN PLAT BOOK 9, PAGE 24 OF THE PUBLIC RECORDS OF SARASOTA COUNTY, FLORIDA.

ANY PERSON CLAIMING AN INTEREST IN THE SURPLUS FROM THE SALE, IF ANY, OTHER THAN THE PROPERTY OWNER AS OF THE DATE OF THE LIS PENDENS MUST FILE A CLAIM WITHIN 60 DAYS AFTER THE SALE.

In accordance with the Americans With Disabilities Act, persons needing a reasonable accommodation to participate in this proceeding should contact the Clerk of the Circuit Court no later than seven business days prior to the proceeding at the Sarasota County Courthouse. Telephone 941-861-7425 (Sarasota and Venice) or 1-800-955-8770 via Florida Relay Service.

Dated this 28 day of September, 2012.

By: Marjorie Levine, Esq.
Bar Number: 96413

Submitted by:
LAW OFFICES OF
MARSHALL C. WATSON, P.A.
1800 NW 49th Street, Suite 120
Fort Lauderdale, Florida 33309
Telephone: (954) 453-0365
Facsimile: (954) 771-6052
Toll Free: 1-800-441-2438
DESIGNATED PRIMARY E-MAIL
FOR SERVICE PURSUANT TO FLA.
R. JUD. ADMIN 2.516
eservice@marshallwatson.com
08-51050
October 5, 12, 2012 12-3812S

SECOND INSERTION

NOTICE OF FORECLOSURE SALE IN THE CIRCUIT COURT OF THE 12TH JUDICIAL CIRCUIT, IN AND FOR SARASOTA COUNTY, FLORIDA

CIVIL DIVISION:
CASE NO.: 2008 CA 014435 NC
AURORA LOAN SERVICES, LLC,
Plaintiff, vs.

LESLIE H LIEBENBERG; U.S. HOME CORPORATION; SHELAGH A LIEBENBERG; JOHN DOE; JANE DOE AS UNKNOWN TENANT (S) IN POSSESSION OF THE SUBJECT PROPERTY,
Defendant(s).

NOTICE IS HEREBY GIVEN pursuant to Final Judgment of Foreclosure dated the 18th day of September 2012 and entered in Case No. 2008 CA 014435 NC, of the Circuit Court of the 12TH Judicial Circuit in and for Sarasota County, Florida, wherein BAYVIEW LOAN SERVICING, LLC, A DELAWARE LIMITED LIABILITY COMPANY AS SERVICER FOR E-TRADE BANK is the Plaintiff and LESLIE H LIEBENBERG, RIVENDELL COMMUNITY ASSOCIATION, INC., U.S. HOME CORPORATION and SHELAGH A LIEBENBERG IN POSSESSION OF THE SUBJECT PROPERTY are defendants. The Clerk of this Court shall sell to the highest and best bidder for cash electronically at www.sarasota.realforeclose.com at, 9:00 AM on the 23rd day of October 2012, the following described property as set forth in said Final Judgment, to wit:

LOT 113, RIVENDELL, UNIT 5, THE WOODLANDS SUBDIVISION, AS PER PLAT THEREOF RECORDED IN PLAT BOOK 42, PAGES 35, 35A THROUGH 35G, OF THE PUBLIC RECORDS OF SARASOTA COUNTY, FLORIDA.

ANY PERSON CLAIMING AN INTEREST IN THE SURPLUS FROM THE SALE, IF ANY, OTHER THAN THE PROPERTY OWNER AS OF THE DATE OF THE LIS PENDENS MUST FILE A CLAIM WITHIN 60 DAYS AFTER THE SALE.

In accordance with the Americans With Disabilities Act, persons needing a reasonable accommodation to participate in this proceeding should contact the Clerk of the Circuit Court no later than seven business days prior to the proceeding at the Sarasota County Courthouse. Telephone 941-861-7425 (Sarasota and Venice) or 1-800-955-8770 via Florida Relay Service.

Dated this 28 day of September, 2012.

By: Greg Homsey, Esq.
Bar Number: 81859

Submitted by:
LAW OFFICES OF
MARSHALL C. WATSON, P.A.
1800 NW 49th Street, Suite 120
Fort Lauderdale, Florida 33309
Telephone: (954) 453-0365
Facsimile: (954) 771-6052
Toll Free: 1-800-441-2438
DESIGNATED PRIMARY E-MAIL
FOR SERVICE PURSUANT TO FLA.
R. JUD. ADMIN 2.516
eservice@marshallwatson.com
08-36798
October 5, 12, 2012 12-3780S

SECOND INSERTION

NOTICE OF FORECLOSURE SALE IN THE CIRCUIT COURT OF THE 12TH JUDICIAL CIRCUIT, IN AND FOR SARASOTA COUNTY, FLORIDA

CIVIL DIVISION:
CASE NO.: 2011 CA 008830 NC
FANNIE MAE ("FEDERAL
NATIONAL MORTGAGE
ASSOCIATION"),
Plaintiff, vs.

RUTH E. BRAMBLE A/K/A RUTH E BRAMBLE; VIVIENDA CONDOMINIUM ASSOCIATION, INC.; UNKNOWN TENANT; IN POSSESSION OF THE SUBJECT PROPERTY,
Defendants.

NOTICE IS HEREBY GIVEN pursuant to Final Judgment of Foreclosure dated the 18th day of September, 2012, and entered in Case No. 2011 CA 008830 NC, of the Circuit Court of the 12TH Judicial Circuit in and for Sarasota County, Florida, wherein FANNIE MAE ("FEDERAL NATIONAL MORTGAGE ASSOCIATION") is the Plaintiff and RUTH E. BRAMBLE A/K/A RUTH E BRAMBLE; VIVIENDA CONDOMINIUM ASSOCIATION, INC.; UNKNOWN TENANT (S); IN POSSESSION OF THE SUBJECT PROPERTY are defendants. The Clerk of this Court shall sell to the highest and best bidder for cash electronically at www.sarasota.realforeclose.com at, 9:00 AM on the 26th day of October, 2012, the following described property as set forth in said Final Judgment, to wit:

UNIT 20, VIVIENDA, PHASE II, SECTION II, A CONDOMINIUM, ACCORDING TO THE DECLARATION

OF CONDOMINIUM, RECORDED IN OFFICIAL RECORDS BOOK 1149, PAGES 1292 THROUGH 1308, AS AMENDED, AND AS PER PLAT THEREOF RECORDED IN CONDOMINIUM BOOK 9, PAGES 31 AND 31A, OF THE PUBLIC RECORDS OF SARASOTA COUNTY, FLORIDA.

ANY PERSON CLAIMING AN INTEREST IN THE SURPLUS FROM THE SALE, IF ANY, OTHER THAN THE PROPERTY OWNER AS OF THE DATE OF THE LIS PENDENS MUST FILE A CLAIM WITHIN 60 DAYS AFTER THE SALE.

In accordance with the Americans With Disabilities Act, persons needing a reasonable accommodation to participate in this proceeding should contact the Clerk of the Circuit Court no later than seven business days prior to the proceeding at the Sarasota County Courthouse. Telephone 941-861-7425 (Sarasota and Venice) or 1-800-955-8770 via Florida Relay Service.

Dated this 1 day of October, 2012.

By: Elisabeth Porter, Esq.
Bar Number: 645648

Submitted by:
LAW OFFICES OF
MARSHALL C. WATSON, P.A.
1800 NW 49th Street, Suite 120
Fort Lauderdale, Florida 33309
Telephone: (954) 453-0365
Facsimile: (954) 771-6052
Toll Free: 1-800-441-2438
DESIGNATED PRIMARY E-MAIL
FOR SERVICE PURSUANT TO FLA.
R. JUD. ADMIN 2.516
eservice@marshallwatson.com
10-29877
October 5, 12, 2012 12-3831S

SECOND INSERTION

NOTICE OF FORECLOSURE SALE IN THE CIRCUIT COURT OF THE 12TH JUDICIAL CIRCUIT, IN AND FOR SARASOTA COUNTY, FLORIDA

CIVIL DIVISION:
CASE NO.: 2009 CA 002508 NC
CHASE HOME FINANCE LLC,
Plaintiff, vs.

JERILYN M MILLER; NATIONAL CITY BANK; VISTAS ON BENEVA CONDOMINIUM ASSOCIATION INC; JOHN W MILLER; UNKNOWN TENANT (S) IN POSSESSION OF THE SUBJECT PROPERTY,
Defendant(s).

NOTICE IS HEREBY GIVEN pursuant to Final Judgment of Foreclosure dated the 18th day of September 2012 and entered in Case No. 2009 CA 002508 NC, of the Circuit Court of the 12TH Judicial Circuit in and for Sarasota County, Florida, wherein JPMORGAN CHASE BANK, N.A. is the Plaintiff and JERILYN M MILLER, NATIONAL CITY BANK, VISTAS ON BENEVA CONDOMINIUM ASSOCIATION INC., JOHN W MILLER, UNKNOWN TENANT(S) N/K/A AARON KESSLER and UNKNOWN TENANT (S) IN POSSESSION OF THE SUBJECT PROPERTY are defendants. The Clerk of this Court shall sell to the highest and best bidder for cash electronically at www.sarasota.realforeclose.com at, 9:00 AM on the 25th day of October 2012, the following described property as set forth in said Final Judgment, to wit:

UNIT 805, VISTAS ON BENEVA, A CONDOMINIUM, ACCORDING TO THE DECLARATION OF CONDOMINIUM THEREOF, AS RECORDED IN OFFI-

CIAL RECORDS INSTRUMENT NO. 2004132741, AS THEREAFTER AMENDED, AND AS PER PLAT THEREOF, RECORDED IN CONDOMINIUM BOOK 37, PAGE 7, AS THEREAFTER AMENDED, OF THE PUBLIC RECORDS OF SARASOTA COUNTY, FLORIDA.

ANY PERSON CLAIMING AN INTEREST IN THE SURPLUS FROM THE SALE, IF ANY, OTHER THAN THE PROPERTY OWNER AS OF THE DATE OF THE LIS PENDENS MUST FILE A CLAIM WITHIN 60 DAYS AFTER THE SALE.

In accordance with the Americans With Disabilities Act, persons needing a reasonable accommodation to participate in this proceeding should contact the Clerk of the Circuit Court no later than seven business days prior to the proceeding at the Sarasota County Courthouse. Telephone 941-861-7425 (Sarasota and Venice) or 1-800-955-8770 via Florida Relay Service.

Dated this 29 day of September, 2012.

By: Nicole J. Saviano, Esq.
Bar Number: 73162

Submitted by:
LAW OFFICES OF
MARSHALL C. WATSON, P.A.
1800 NW 49th Street, Suite 120
Fort Lauderdale, Florida 33309
Telephone: (954) 453-0365
Facsimile: (954) 771-6052
Toll Free: 1-800-441-2438
DESIGNATED PRIMARY E-MAIL
FOR SERVICE PURSUANT TO FLA.
R. JUD. ADMIN 2.516
eservice@marshallwatson.com
09-09791
October 5, 12, 2012 12-3811S

SECOND INSERTION

RE-NOTICE OF FORECLOSURE SALE IN THE CIRCUIT COURT OF THE 12TH JUDICIAL CIRCUIT, IN AND FOR SARASOTA COUNTY, FLORIDA

CIVIL DIVISION:
CASE NO.: 2010 CA 008727 NC
AURORA LOAN SERVICES, LLC,
Plaintiff, vs.

JAMES BOBACK, JR. A/K/A JAMES E. BOBACK, JR.; UNKNOWN SPOUSE OF JAMES BOBACK, JR. A/K/A JAMES E. BOBACK, JR.; UNKNOWN TENANT (S); IN POSSESSION OF THE SUBJECT PROPERTY,
Defendant(s).

NOTICE IS HEREBY GIVEN pursuant to an Order Resetting Foreclosure Sale dated the 22nd day of August 2012 and entered in Case No. 2010 CA 008727 NC, of the Circuit Court of the 12TH Judicial Circuit in and for Sarasota County, Florida, wherein AURORA LOAN SERVICES, LLC is the Plaintiff and JAMES BOBACK, JR. A/K/A JAMES E. BOBACK, JR., UNKNOWN SPOUSE OF NELLIE A. BOBACK, UNKNOWN SPOUSE OF JAMES BOBACK, JR. A/K/A JAMES E. BOBACK, JR. N/K/A JAMES E. BOBACK, JR. and UNKNOWN TENANT (S) IN POSSESSION OF THE SUBJECT PROPERTY are defendants. The Clerk of this Court shall sell to the highest and best bidder for cash electronically at www.sarasota.realforeclose.com at, 9:00 AM on the 22nd day of October 2012 the following described property as set forth in said Final Judgment, to wit:

LOT 33, BLOCK 472, 8TH ADDITION TO PORT CHARLOTTE SUBDIVISION, A SUBDIVISION ACCORDING TO THE PLAT THEREOF, AS RECORDED IN PLAT BOOK 12, PAGE 20, OF THE PUBLIC RECORDS OF SARASOTA COUNTY, FLORIDA.

ANY PERSON CLAIMING AN INTEREST IN THE SURPLUS FROM THE SALE, IF ANY, OTHER THAN THE PROPERTY OWNER AS OF THE DATE OF THE LIS PENDENS MUST FILE A CLAIM WITHIN 60 DAYS AFTER THE SALE.

In accordance with the Americans With Disabilities Act, persons needing a reasonable accommodation to participate in this proceeding should contact the Clerk of the Circuit Court no later than seven business days prior to the proceeding at the Sarasota County Courthouse. Telephone 941-861-7425 (Sarasota and Venice) or 1-800-955-8770 via Florida Relay Service.

Dated this 28 day of September, 2012.

By: Elisabeth Porter, Esq.
Bar Number: 645648

Submitted by:
LAW OFFICES OF
MARSHALL C. WATSON, P.A.
1800 NW 49th Street, Suite 120
Fort Lauderdale, Florida 33309
Telephone: (954) 453-0365
Facsimile: (954) 771-6052
Toll Free: 1-800-441-2438
DESIGNATED PRIMARY E-MAIL
FOR SERVICE PURSUANT TO FLA.
R. JUD. ADMIN 2.516
eservice@marshallwatson.com
10-35017
October 5, 12, 2012 12-3783S

SECOND INSERTION

NOTICE OF SALE
IN THE CIRCUIT CIVIL COURT OF
THE TWELFTH JUDICIAL
CIRCUIT OF FLORIDA, IN AND
FOR SARASOTA COUNTY
CIVIL DIVISION
Case No. 58-2011-CA-002653 NC
Division C

US BANK, N.A.
Plaintiff, vs.
TIFFANY A. FARRELL A/K/A
TIFFANY FARRELL A/K/A
TIFFANY FERRELL F/K/A
TIFFANY A. C. DUCKWORTH,
BENJAMIN FARRELL, AND
UNKNOWN TENANTS/OWNERS,
Defendants.

Notice is hereby given, pursuant to Final Judgment of Foreclosure for Plaintiff entered in this cause on September 24, 2012, in the Circuit Court of Sarasota County, Florida, The Clerk of the Court will sell the property situated in Sarasota County, Florida described as:

LOT 3, BLOCK B, TERRACE GARDENS, ACCORDING TO THE MAP OR PLAT THEREOF AS RECORDED IN PLAT BOOK 4, PAGE 89, PUBLIC RECORDS OF SARASOTA COUNTY, FLORIDA.

and commonly known as: 129 S SHADE AVE, SARASOTA, FL 34237;

including the building, appurtenances, and fixtures located therein, at public sale, to the highest and best bidder, for cash, Sales are held online at: https://www.sarasota.realforeclose.com, on October 31, 2012 at 9:00 A.M..

Any persons claiming an interest in the surplus from the sale, if any, other than the property owner as of the date of the lis pendens must file a claim within 60 days after the sale.

In accordance with the Americans With Disabilities Act, persons needing a reasonable accommodation to participate in this proceeding should contact the Clerk of the Circuit Court no later than seven business days prior to the proceeding at the Sarasota County Courthouse. Telephone 941-861-7425 (Sarasota and Venice) or 1-800-955-8770 via Florida Relay Service.

Dated this 24th day of September, 2012.

Karen E. Rushing
By: Frances Grace Cooper, Esquire
Attorney for Plaintiff

Edward B. Pritchard
(813) 229-0900 x1309
KASS SHULER, P.A.
P.O. Box 800
Tampa, FL 33601-0800
October 5, 12, 2012 12-3772S

SECOND INSERTION

NOTICE OF FORECLOSURE SALE
IN THE CIRCUIT COURT IN
AND FOR SARASOTA COUNTY,
FLORIDA

CASE NO. 2009 CA 012555 NC
JP MORGAN CHASE BANK,
NATIONAL ASSOCIATION,
Plaintiff, vs.

APRIL FOSSETT; UNKNOWN
SPOUSE OF APRIL FOSSETT;
BANK OF AMERICA, N.A.;
UNKNOWN TENANT #1;
UNKNOWN TENANT #2;
UNKNOWN TENANT #3;
UNKNOWN TENANT #4,
Defendant(s)

NOTICE is hereby given that the Clerk of the Circuit Court of Sarasota County, Florida, will on the 29th day of October 2012, at 9:00am www.sarasota.realforeclose.com in accordance with Chapter 45 Florida Statutes, offer for sale and sell at public outcry to the highest and best bidder for cash, the following-described property situate in Sarasota County, Florida:

LOTS 15, BLOCK 6, CITRUS HIGHLANDS SUBDIVISION, AS PER PLAT THEREOF RECORDED IN PLAT BOOK 8, PAGE 59 AND 59A, OF THE PUBLIC RECORDS OF SARASOTA COUNTY, FLORIDA.

pursuant to the Final Judgment en-

tered in a case pending in said Court, the style of which is indicated above.

Any person or entity claiming an interest in the surplus, if any, resulting from the foreclosure sale, other than the property owner as of the date of the Lis Pendens, must file a claim on same with the Clerk of Court within 60 days after the foreclosure sale.

In accordance with the Americans With Disabilities Act, persons needing a reasonable accommodation to participate in this proceeding should contact the Clerk of the Circuit Court no later than seven business days prior to the proceeding at the Sarasota County Courthouse. Telephone 941-861-7425 (Sarasota and Venice) or 1-800-955-8770 via Florida Relay Service.

DATED this 26 day of September, 2012.

Wendy S. Griffith, Esquire
BUTLER & HOSCH, P.A.
3185 South Conway Road, Suite E
Orlando, Florida 32812
Telephone: (407) 381-5200
Fax: (407) 381-5577
Florida Bar No: 72840
Service Emails:
wg72840@butlerandhosch.com
FLPleadings@butlerandhosch.com
B&H # 296057
October 5, 12, 2012 12-3765S

SECOND INSERTION

NOTICE OF SALE
IN THE CIRCUIT COURT OF THE
TWELFTH JUDICIAL CIRCUIT IN
AND FOR SARASOTA
COUNTY, FLORIDA

CASE NO. 2011 CA 001162 NC
U.S. BANK, N.A.
Plaintiff, vs.

H. ROBERT HOFFERBERTH
A/K/A ROBERT HOFFERBERTH
INDIVIDUALLY AND AS
CO-TRUSTEE OF THE

HOFFERBERTH FAMILY
TRUST DATED THE 29TH DAY
OF MARCH 2007; JEAN A.
HOFFERBERTH, INDIVIDUALLY
AND AS CO-TRUSTEE OF

THE HOFFERBERTH FAMILY
TRUST DATED THE 29TH DAY
OF MARCH 2007; UNKNOWN
TENANT 1; UNKNOWN TENANT

2; AND ALL UNKNOWN PARTIES
CLAIMING BY, THROUGH,
UNDER OR AGAINST THE
ABOVE NAMED DEFENDANT(S),
WHO (IS/ARE) NOT KNOWN TO
BE DEAD OR ALIVE, WHETHER
SAID UNKNOWN PARTIES
CLAIM AS HEIRS, DEVISEES,
GRANTEES, ASSIGNEES,
LIENORS, CREDITORS,
TRUSTEES, SPOUSES, OR
OTHER CLAIMANTS; LL
CONDOMINIUM ASSOCIATION,
INC.

Defendants.

Notice is hereby given that, pursuant to the Summary Final Judgment of Foreclosure entered on September 24, 2012, in this cause, in the Circuit Court of Sarasota County, Florida, the clerk shall sell the property situated in Sarasota County, Florida, described as:

UNIT 19, LOS LAGOS CONDOMINIUM, A CONDOMINIUM, TOGETHER WITH AN UNDIVIDED INTEREST IN THE COMMON ELEMENTS APPURTENANT THERETO, ACCORDING TO THE DECLAR-

ATION OF CONDOMINIUM THEREOF, AS RECORDED IN OFFICIAL RECORDS BOOK 1604, AT PAGES 612 TO 648, INCLUSIVE, AND SUBSEQUENT AMENDMENTS THERETO AND AS PER PLAT THEREOF RECORDED IN CONDOMINIUM BOOK 20, PAGE 46, AND AS AMENDED, OF THE PUBLIC RECORDS OF SARASOTA COUNTY, FLORIDA.

a/k/a 3013 CLARK RD. UNIT 19, SARASOTA, FL 34231

at public sale, to the highest and best bidder, for cash, online at www.sarasota.realforeclose.com, Sarasota County, Florida, on October 31, 2012 at 09:00 AM.

Any person claiming an interest in the surplus from the sale, if any, other than the property owner as of the date of the lis pendens must file a claim within 60 days after the sale.

In accordance with the Americans With Disabilities Act, persons needing a reasonable accommodation to participate in this proceeding should contact the Clerk of the Circuit Court no later than seven business days prior to the proceeding at the Sarasota County Courthouse. Telephone 941-861-7425 (Sarasota and Venice) or 1-800-955-8770 via Florida Relay Service.

Dated at St. Petersburg, Florida, this 2 day of October, 2012.

Karen E. Rushing
Clerk of the Circuit Court
Tara M. McDonald, Esquire
Tara M. McDonald, Esquire
Florida Bar No. 43941

DOUGLAS C. ZAHM, P.A.
12425 28th Street North, Suite 200
St. Petersburg, FL 33716
Telephone No. (727) 536-4911
Fax No. (727) 539-1094
Attorney for Plaintiff
665101858
October 5, 12, 2012 12-3868S

SECOND INSERTION

NOTICE OF SALE
IN THE CIRCUIT CIVIL COURT OF
THE TWELFTH JUDICIAL
CIRCUIT OF FLORIDA, IN AND
FOR SARASOTA COUNTY
CIVIL DIVISION
Case No. 2011 CA 001528 NC
Division C

WELLS FARGO BANK, N.A.
Plaintiff, vs.
LORI PIERCE, SOUTH VENICE
CIVIC ASSOCIATION, INC.
UNKNOWN TENANT (S) AND
UNKNOWN TENANTS/OWNERS,
Defendants.

Notice is hereby given, pursuant to Final Judgment of Foreclosure for Plaintiff entered in this cause on September 24, 2012, in the Circuit Court of Sarasota County, Florida, The Clerk of the Court will sell the property situated in Sarasota County, Florida described as:

LOT 2971 AND 2972, SOUTH VENICE SUBDIVISION, UNIT 10, A SUBDIVISION ACCORDING TO THE PLAT THEREOF AS RECORDED IN PLAT BOOK 6, PAGE 46, OF THE PUBLIC RECORDS OF SARASOTA COUNTY, FLORIDA.

and commonly known as: 720 CY-PRESS ROAD, VENICE, FL 34293; including the building, appurtenances, and fixtures located therein, at public sale, to the highest and best bidder, for cash, Sales are held online at: https://www.sarasota.realforeclose.com, on OCTOBER 31, 2012 at 9:00 A.M..

Any persons claiming an interest in the surplus from the sale, if any, other than the property owner as of the date of the lis pendens must file a claim within 60 days after the sale.

In accordance with the Americans With Disabilities Act, persons needing a reasonable accommodation to participate in this proceeding should contact the Clerk of the Circuit Court no later than seven business days prior to the proceeding at the Sarasota County Courthouse. Telephone 941-861-7425 (Sarasota and Venice) or 1-800-955-8770 via Florida Relay Service.

Dated this 24th day of September, 2012.

Karen E. Rushing
By: Frances Grace Cooper, Esquire
Attorney for Plaintiff

Lauren A. Ross
(813) 229-0900 x1556
KASS SHULER, P.A.
P.O. Box 800
Tampa, FL 33601-0800
October 5, 12, 2012 12-3773S

SECOND INSERTION

NOTICE OF FORECLOSURE SALE
IN THE CIRCUIT COURT IN
AND FOR SARASOTA COUNTY,
FLORIDA

CASE NO. 2010 CA 002524 NC
JP MORGAN CHASE BANK,
NATIONAL ASSOCIATION,
Plaintiff, vs.

GLENN E. KORTE; BARBARA
A. MARMAN KORTE; REGIONS
BANK AS SUCCESSOR BY
MERGER WITH AMSOUTH
BANK; UNKNOWN TENANT #1;
UNKNOWN TENANT #2,
Defendant(s)

NOTICE is hereby given that the Clerk of the Circuit Court of Sarasota County, Florida, will on the 22nd day of January 2013, at 9:00am www.sarasota.realforeclose.com in accordance with Chapter 45 Florida Statutes, offer for sale and sell at public outcry to the highest and best bidder for cash, the following-described property situate in Sarasota County, Florida:

LOT 2, BLOCK 300, GOLDEN BEACH, UNIT 3, SUBDIVISION ACCORDING TO THE PLAT THEREOF, RECORDED IN PLAT BOOK 9, PAGE 45, OF THE PUBLIC RECORDS OF SARASOTA COUNTY, FLORIDA.

pursuant to the Final Judgment entered in a case pending in said Court, the style of which is indicated above.

Any person or entity claiming an interest in the surplus from the foreclosure sale, other than the property owner as of the date of the Lis Pendens, must file a claim on same with the Clerk of Court within 60 days after the foreclosure sale.

In accordance with the Americans With Disabilities Act, persons needing a reasonable accommodation to participate in this proceeding should contact the Clerk of the Circuit Court no later than seven business days prior to the proceeding at the Sarasota County Courthouse. Telephone 941-861-7425 (Sarasota and Venice) or 1-800-955-8770 via Florida Relay Service.

DATED this 26 day of September, 2012.

Wendy S. Griffith, Esquire
BUTLER & HOSCH, P.A.
3185 South Conway Road, Suite E
Orlando, Florida 32812
Telephone: (407) 381-5200
Fax: (407) 381-5577
Florida Bar No: 72840
Service Emails:
wg72840@butlerandhosch.com
FLPleadings@butlerandhosch.com
B&H # 295669
October 5, 12, 2012 12-3766S

SECOND INSERTION

NOTICE OF SALE PURSUANT TO
CHAPTER 45
IN THE CIRCUIT COURT OF THE
TWELFTH JUDICIAL CIRCUIT
IN AND FOR SARASOTA COUNTY,
FLORIDA
CIVIL ACTION
CASE NO.: 2008 CA 015271 NC
DIVISION: C

WACHOVIA MORTGAGE, FSB,
F.K.A WORLD SAVINGS BANK,
Plaintiff, vs.
MARY E. KURTZ, et al,
Defendant(s).

NOTICE IS HEREBY GIVEN Pursuant to a Final Judgment of Foreclosure dated June 26, 2012, and entered in Case No. 2008 CA 015271 NC of the Circuit Court of the Twelfth Judicial Circuit in and for Sarasota County, Florida in which Wachovia Mortgage, FSB, f.k.a World Savings Bank, is the Plaintiff and Mary E. Kurtz, et al, are defendants, I will sell to the highest and best bidder for cash in/on the Internet: www.sarasota.realforeclose.com, Sarasota County, Florida at 9:00am on the 29th day of October, 2012, the following described property as set forth in said Final Judgment of Foreclosure:

LOT 72, SHERWOOD ESTATES, UNIT NO. 2, AS PER PLAT THEREOF RECORDED IN PLAT BOOK 10, PAGE 43, OF THE PUBLIC RECORDS OF SARASOTA COUNTY, FLORIDA
A/K/A 4616 EAST LAKE CIRCLE, SARASOTA, FLORIDA 34232

Any person claiming an interest in the surplus from the sale, if any, other than the property owner as of the date of the Lis Pendens must file a claim within 60 days after the sale.

In accordance with the Americans With Disabilities Act, persons needing a reasonable accommodation to participate in this proceeding should contact the Clerk of the Circuit Court no later than seven business days prior to the proceeding at the Sarasota County Courthouse. Telephone 941-861-7425 (Sarasota and Venice) or 1-800-955-8770 via Florida Relay Service.

DATED this 26 day of September, 2012.

Albertelli Law
Attorney for Plaintiff
P.O. Box 23028
Tampa, FL 33623
(813) 221-4743
(813) 221-9171 facsimile
eService:
servealaw@albertellilaw.com
CH - 08-09352
October 5, 12, 2012 12-3845S

SECOND INSERTION

NOTICE OF SALE PURSUANT TO
CHAPTER 45
IN THE CIRCUIT COURT OF THE
TWELFTH JUDICIAL CIRCUIT
IN AND FOR SARASOTA COUNTY,
FLORIDA
CIVIL ACTION
CASE NO.: 2008 CA 018903 NC
DIVISION: A

WACHOVIA MORTGAGE, F.S.B.
F/K/A WORLD SAVINGS BANK,
F.S.B.,
Plaintiff, vs.
LEONID LEBED, et al,
Defendants.

NOTICE IS HEREBY GIVEN Pursuant to a Final Judgment of Foreclosure dated June 25, 2012, and entered in Case No. 2008 CA 018903 NC of the Circuit Court of the Twelfth Judicial Circuit in and for Sarasota County, Florida in which Wachovia Mortgage, F.S.B. f/k/a World Savings Bank, F.S.B., is the Plaintiff and Leonid Lebed, Lyudmila Lebed, Wachovia Mortgage, F.S.B. f/k/a World Savings Bank, F.S.B., are defendants, I will sell to the highest and best bidder for cash in/on the Internet: www.sarasota.realforeclose.com, Sarasota County, Florida at 9:00am on the 19th day of October, 2012, the following described property as set forth in said Final Judgment of Foreclosure:

LOTS 19524, 19525, 19526 AND 19527, SOUTH VENICE, UNIT 75, ACCORDING TO THE PLAT THEREOF, AS RECORDED IN PLAT BOOK 7, PAGE 76, OF THE PUBLIC RECORDS OF SARASOTA COUNTY, FLORIDA.

A/K/A 450 PONDEROSA ROAD, VENICE, FL 34293

Any person claiming an interest in the surplus from the sale, if any, other than the property owner as of the date of the Lis Pendens, must file a claim within 60 days after the sale.

In accordance with the Americans With Disabilities Act, persons needing a reasonable accommodation to participate in this proceeding should contact the Clerk of the Circuit Court no later than seven business days prior to the proceeding at the Sarasota County Courthouse. Telephone 941-861-7425 (Sarasota and Venice) or 1-800-955-8770 via Florida Relay Service.

Dated: September 27, 2012.
FLORIDA FORECLOSURE ATTORNEYS, PLLC
By: /s/ Brad Abramson
Brad S. Abramson, Esquire
(FBN 87554)
babramson@ffaplcc.com
601 Cleveland Street, Suite 690
Clearwater, FL 33755
(727) 446-4826
CA11-00928 /AA
October 5, 12, 2012 12-3759S

SECOND INSERTION

NOTICE OF FORECLOSURE SALE
IN THE CIRCUIT COURT OF THE
TWELFTH JUDICIAL CIRCUIT,
IN AND FOR SARASOTA COUNTY,
FLORIDA

CIRCUIT CIVIL DIVISION
Case No.: 58-2009-CA-015110 NC
THE BANK OF NEW YORK
MELLON F/K/A/ THE BANK OF
NEW YORK AS TRUSTEE FOR
THE CERTIFICATEHOLDERS
OF CWABS, INC. ASSET-BACKED
NOTES TRUST 2007-SD1;
Plaintiff, vs.

JOHN G. MURGES, et al.,
Defendants.

NOTICE IS HEREBY GIVEN pursuant to an Order or Final Judgment entered in Case No. 58-2009-CA-015110 NC of the Circuit Court of the TWELFTH Judicial Circuit in and for SARASOTA County, Florida, wherein, THE BANK OF NEW YORK MELLON F/K/A/ THE BANK OF NEW YORK AS TRUSTEE FOR THE CERTIFICATEHOLDERS OF CWABS, INC. ASSET-BACKED NOTES TRUST 2007-SD1, Plaintiff, and, JOHN G. MURGES, et al., are Defendants, the Clerk of the Court will sell to the highest bidder for cash at www.sarasota.realforeclosure.com at the hour of 9:00 AM on the 26TH day of OCTOBER 2012, the following described property:

LOT 68, THE SETTLEMENT, UNIT III, ACCORDING TO THE PLAT THEREOF RECORDED IN PLAT BOOK 33, PAGE 34, 34A THROUGH 34C, INCLUSIVE, OF THE PUBLIC RECORDS OF SARASOTA COUNTY, FLORIDA.

Any person claiming an interest in the surplus from the sale, if any, other than the property owner as of the date of the Lis Pendens must file a claim within 60 days after the sale.

In accordance with the Americans With Disabilities Act, persons needing a reasonable accommodation to participate in this proceeding should contact the Clerk of the Circuit Court no later than seven business days prior to the proceeding at the Sarasota County Courthouse. Telephone 941-861-7425 (Sarasota and Venice) or 1-800-955-8770 via Florida Relay Service.

DATED this 26 day of September, 2012.

By: Sarah M. Barbaccia
FBN 30043
MORALES LAW GROUP, P.A.
14750 NW 77th Ct., Ste 303
Miami Lakes, FL 33016
October 5, 12, 2012 12-3776S

SECOND INSERTION

NOTICE OF SALE
IN THE CIRCUIT COURT OF THE
TWELFTH JUDICIAL CIRCUIT
IN AND FOR SARASOTA COUNTY,
FLORIDA, CIVIL ACTION

CASE NO.: 2009 CA 010019 NC
BAC HOME LOANS SERVICING
L.P. F/K/A COUNTRYWIDE HOME
LOANS SERVICING L.P.,
Plaintiff, vs.

JAMES W MORELAND, et al,
Defendant(s).

Notice is hereby given that, pursuant to a Order Rescheduling dated September 25th, 2012 entered in Civil Case Number 2009 CA 010019 NC, in the Circuit Court for Sarasota County, Florida, wherein BAC HOME LOANS SERVICING L.P. F/K/A COUNTRYWIDE HOME LOANS SERVICING L.P. is the Plaintiff, and JAMES W MORELAND, et al., are the Defendants, Sarasota County Clerk of Court will sell the property situated in Sarasota County, Florida, described as:

LOT 10, BLOCK 1260, 27TH ADDITION TO PORT CHARLOTTE SUBDIVISION, ACCORDING TO THE PLAT THEREOF AS RECORDED IN PLAT BOOK 15, PAGES 11, 11A THROUGH 11M, INCLUSIVE, OF THE PUBLIC RECORDS OF SARASOTA COUNTY, FLORIDA.

at public sale, to the highest and best bidder, for cash, at www.sarasota.realforeclose.com at 09:00 AM, on the 26th day of October, 2012. Any person claiming an interest in the surplus from the sale, if any, other than the property owner as of the date of the lis pendens must file a claim within 60 days after the sale.

In accordance with the Americans With Disabilities Act, persons needing a reasonable accommodation to participate in this proceeding should contact the Clerk of the Circuit Court no later than seven business days prior to the proceeding at the Sarasota County Courthouse. Telephone 941-861-7425 (Sarasota and Venice) or 1-800-955-8770 via Florida Relay Service.

Dated: September 27, 2012.
FLORIDA FORECLOSURE ATTORNEYS, PLLC
By: /s/ Brad Abramson
Brad S. Abramson, Esquire
(FBN 87554)
babramson@ffaplcc.com
601 Cleveland Street, Suite 690
Clearwater, FL 33755
(727) 446-4826
CA11-00928 /AA
October 5, 12, 2012 12-3768S

SECOND INSERTION

NOTICE OF SALE
IN THE CIRCUIT COURT OF THE
TWELFTH JUDICIAL CIRCUIT
IN AND FOR
SARASOTA COUNTY, FLORIDA

CASE NO. 2011 CA 005812 NC
U.S. BANK, N.A. AS TRUSTEE
OF THE FLORIDA MORTGAGE
RESOLUTION TRUST, SERIES
2012-4,
Plaintiff, vs.

JAMES A. BENNETT,
Defendants.

NOTICE IS HEREBY GIVEN that, pursuant to the Uniform Final Summary Judgment of Mortgage Foreclosure entered on September 24, 2012 in the above-captioned action, the following property situated in Sarasota County, Florida, described as:

THE FOLLOWING DESCRIBED LAND, SITUATE, LYING AND BEING IN SARASOTA COUNTY, FLORIDA, TO-WIT: TRACT 21, LESS THE SOUTH 150 FEET, OF VENICE GROVES SUBDIVISION, AS PER PLAT THEREOF RECORDED IN PLAT BOOK 3, PAGE 2, OF THE PUBLIC RECORDS OF SARASOTA COUNTY, FLORIDA.

Shall be sold by the Clerk of Court on the 31st day of October, 2012 on-line at 9:00 a.m. (Eastern Time) at www.sarasota.realforeclose.com to the highest bidder, for cash, after giving notice as required by section 45.031, Florida Statutes.

Any person claiming an interest in the surplus from the sale, if any, other than the owner as of the date of the Lis Pendens must file a claim within 60 days after the sale. The court, in its discretion, may enlarge the time of the sale. Notice of the changed time of sale shall be published as provided herein.

In accordance with the Americans With Disabilities Act, persons needing a reasonable accommodation to participate in this proceeding should contact the Clerk of the Circuit Court no later than seven business days prior to the proceeding at the Sarasota County Courthouse. Telephone 941-861-7425 (Sarasota and Venice) or 1-800-955-8770 via Florida Relay Service.

Suzanne Delaney
THORNE & STOREY, P.A.

212 Pasadena Place
Orlando, FL 32803
(407) 488-1222
Attorneys for Plaintiff
Fl. Bar No.: 0957941
October 5, 12, 2012 12-3779S

SECOND INSERTION

NOTICE OF FORECLOSURE SALE
IN THE CIRCUIT COURT OF THE
TWELFTH JUDICIAL CIRCUIT, IN
AND FOR SARASOTA COUNTY,
FLORIDA

CIVIL ACTION
CASE NO.: 58 2009 CA 003137 NC
DIVISION: A

CHASE HOME FINANCE LLC,
Plaintiff, vs.
NICOLE E. TEDESCO, et al,
Defendant(s).

NOTICE IS HEREBY GIVEN pursuant to a Final Judgment of Mortgage Foreclosure dated September 24, 2012 and entered in Case No. 58 2009 CA 003137 NC of the Circuit Court of the TWELFTH Judicial Circuit in and for SARASOTA County, Florida wherein CHASE HOME FINANCE LLC is the Plaintiff and NICOLE E. TEDESCO; TIMOTHY J. PRINGLE; JPMORGAN CHASE BANK, N.A.; are the Defendants, The Clerk will sell to the highest and best bidder for cash at WWW.SARASOTA.REALFORECLOSE.COM at 9:00AM, on the 29th day of October, 2012, the following described property as set forth in said Final Judgment:

LOT 8, BLOCK 287, 1ST ADDITION TO PORT CHARLOTTE SUBDIVISION, A SUBDIVISION ACCORDING TO THE PLAT THEREOF, RECORDED IN PLAT BOOK 11, PAGES 29, 29A THROUGH 29J, OF THE PUBLIC RECORDS OF SARASOTA COUNTY, FLORIDA.

A/K/A 4306 WORCESTER AVENUE, NORTH PORT, FL 342860000

Any person claiming an interest in the surplus from the sale, if any, other than the property owner as of the date of the Lis Pendens must file a claim within sixty (60) days after the sale.

In accordance with the Americans With Disabilities Act, persons needing a reasonable accommodation to participate in this proceeding should contact the Clerk of the Circuit Court no later than seven business days prior to the proceeding at the Sarasota County Courthouse. Telephone 941-861-7425 (Sarasota and Venice) or 1-800-955-8770 via Florida Relay Service.

By: Salina B. Klinghammer
Florida Bar No. 86041

RONALD R WOLFE &
ASSOCIATES, P.L.
P.O. Box 25018
Tampa, Florida 33622-5018
(813) 251-4766
F09020224
October 5, 12, 2012 12-3791S

**PUBLISH YOUR
LEGAL NOTICES
IN THE GULF COAST BUSINESS REVIEW**
(800) 403-2493 Hillsborough, Pasco
(727) 447-7784 Pinellas
(941) 906-9386 Manatee, Sarasota, Lee
(239) 594-5387 Collier

SECOND INSERTION

NOTICE OF FORECLOSURE SALE IN THE CIRCUIT COURT OF THE 12TH JUDICIAL CIRCUIT, IN AND FOR SARASOTA COUNTY, FLORIDA

CIVIL DIVISION:
CASE NO.: 2010 CA 007951 NC
CITIMORTGAGE, INC.,
Plaintiff, vs.
GARY L VALLE; THERESA VALLE;
UNKNOWN TENANT (S) #1;
UNKNOWN TENANT (S) #2; IN
POSSESSION OF THE SUBJECT
PROPERTY,
Defendant(s).

NOTICE IS HEREBY GIVEN pursuant to Final Judgment of Foreclosure dated the 18th day of September 2012 and entered in Case No. 2010 CA 007951 NC, of the Circuit Court of the 12TH Judicial Circuit in and for Sarasota County, Florida, wherein CITIMORTGAGE, INC. is the Plaintiff and GARY L VALLE, UNKNOWN TENANT (S) N/K/A LUKE BLUVOISE, UNKNOWN TENANT(S) and THERESA VALLE IN POSSESSION OF THE SUBJECT PROPERTY are defendants. The Clerk of this Court shall sell to the highest and best bidder for cash electronically at www.sarasota.realforeclose.com at, 9:00 AM on the 23rd day of October 2012 the following described property as set forth in said Final Judgment, to wit:

LOT 41, BLOCK A, WARM MINERAL SPRINGS, UNIT 90, A SUBDIVISION ACCORDING TO THE PLAT THEREOF AS RECORDED IN PLAT BOOK 17, PAGE 4, OF THE PUBLIC RECORDS OF SARASOTA COUNTY, FLORIDA

ANY PERSON CLAIMING AN INTEREST IN THE SURPLUS FROM THE SALE, IF ANY, OTHER THAN THE PROPERTY OWNER AS OF THE DATE OF THE LIS PENDENS MUST FILE A CLAIM WITHIN 60 DAYS AFTER THE SALE.

In accordance with the Americans With Disabilities Act, persons needing a reasonable accommodation to participate in this proceeding should contact the Clerk of the Circuit Court no later than seven business days prior to the proceeding at the Sarasota County Courthouse. Telephone 941-861-7425 (Sarasota and Venice) or 1-800-955-8770 via Florida Relay Service.

Dated this 28 day of September, 2012.

By: Elisabeth Porter, Esq.
Bar Number: 645648

Submitted by:
LAW OFFICES OF
MARSHALL C. WATSON, P.A.
1800 NW 49th Street, Suite 120
Fort Lauderdale, Florida 33309
Telephone: (954) 453-0365
Facsimile: (954) 771-6052
Toll Free: 1-800-441-2438
DESIGNATED PRIMARY E-MAIL
FOR SERVICE PURSUANT TO FLA.
R. JUD. ADMIN 2.516
eservice@marshallwatson.com
10-04030
October 5, 12, 2012 12-3782S

SECOND INSERTION

NOTICE OF SALE IN THE CIRCUIT COURT OF THE TWELFTH JUDICIAL CIRCUIT IN AND FOR SARASOTA COUNTY, FLORIDA

CASE NO. 2010 CA 007087 NC
WELLS FARGO BANK, N.A.
Plaintiff, v.
KEVIN W. ENDEE; KAREN M. ENDEE; UNKNOWN TENANT 1; UNKNOWN TENANT 2; AND ALL UNKNOWN PARTIES CLAIMING BY, THROUGH, UNDER OR AGAINST THE ABOVE NAMED DEFENDANT(S), WHO (IS/ARE) NOT KNOWN TO BE DEAD OR ALIVE, WHETHER SAID UNKNOWN PARTIES CLAIM AS HEIRS, DEVISEES, GRANTEEES, ASSIGNEES, LIENORS, CREDITORS, TRUSTEES, SPOUSES, OR OTHER CLAIMANTS; AMERICAN EXPRESS TRAVEL RELATED SERVICES COMPANY, INC.
Defendants.

Notice is hereby given that, pursuant to the Summary Final Judgment of Foreclosure entered on September 24, 2012, in this cause, in the Circuit Court of Sarasota County, Florida, the clerk shall sell the property situated in Sarasota County, Florida, described as:

Lot 15, Block 1795 of 37th Addition to Port Charlotte Subdivision, a Subdivision according to the Plat thereof, as recorded in Plat Book 16, at Pages 4, 4A through 4H, in the Public Records of Sarasota County, Florida.

a/k/a 2214 HOPWOOD RD., NORTH PORT, FL 34287
at public sale, to the highest and best bidder, for cash, online at www.sarasota.realforeclose.com, Sarasota County, Florida, on October 30, 2012 at 09:00 AM.

Any person claiming an interest in the surplus from the sale, if any, other than the property owner as of the date of the lis pendens must file a claim within 60 days after the sale.

In accordance with the Americans With Disabilities Act, persons needing a reasonable accommodation to participate in this proceeding should contact the Clerk of the Circuit Court no later than seven business days prior to the proceeding at the Sarasota County Courthouse. Telephone 941-861-7425 (Sarasota and Venice) or 1-800-955-8770 via Florida Relay Service.
Dated at St. Petersburg, Florida, this 2 day of October, 2012.

Karen E. Rushing
Clerk of the Circuit Court
s/ Tara M. McDonald, Esquire
Tara M. McDonald, Esquire
Florida Bar No. 43941
DOUGLAS C. ZAHM, P.A.
12425 28th Street North, Suite 200
St. Petersburg, FL 33716
Telephone No. (727) 536-4911
Fax No. (727) 539-1094
Attorney for Plaintiff
888101219
October 5, 12, 2012 12-3867S

SECOND INSERTION

NOTICE OF SALE IN THE CIRCUIT CIVIL COURT OF THE TWELFTH JUDICIAL CIRCUIT OF FLORIDA, IN AND FOR SARASOTA COUNTY CIVIL DIVISION

Case No. 2009-CA-002184-NC
Division C
CITIMORTGAGE, INC,
SUCCESSOR BY MERGER TO ABN AMRO MORTGAGE GROUP, INC.
Plaintiff, vs.
ROBERT H. WILSON, JR A/K/A ROBERT H. WILSON, LINDA J. WILSON A/K/A LINDA WILSON, SARASOTA EASTPOINTE HOMEOWNERS ASSOCIATION, INC, BANK OF AMERICA, NATIONAL ASSOCIATION, ANY AND ALL UNKNOWN PARTIES CLAIMING BY, THROUGH, UNDER, AND AGAINST THE HEREIN NAMED INDIVIDUAL DEFENDANT(S) WHO ARE NOT KNOWN TO BE DEAD OR ALIVE, WHETHER SAID UNKNOWN PARTIES MAY CLAIM AN INTEREST AS SPOUSES, HEIRS, DEVISEES, GRANTEEES OR OTHER CLAIMANTS, AND UNKNOWN TENANTS/OWNERS,
Defendants.

Notice is hereby given, pursuant to Final Judgment of Foreclosure for Plaintiff entered in this cause on , in the Circuit Court of Sarasota County, Florida, The Clerk of the Court will sell the property situated in Sarasota County, Florida described as:

LOT 12, EASTPOINTE, PHASE 1, ACCORDING TO THE PLAT THEREOF, AS RECORDED IN PLAT BOOK 31, PAGE 1 & 1A, OF THE PUBLIC RECORDS OF SARASOTA COUNTY, FLORIDA.

and commonly known as: 5335 SARAPOINTE DR, SARASOTA, FL 34232; including the building, appurtenances, and fixtures located therein, at public sale, to the highest and best bidder, for cash, Sales are held online at: https://www.sarasota.realforeclose.com, on NOVEMBER 2, 2012 at 9:00 A.M..

Any persons claiming an interest in the surplus from the sale, if any, other than the property owner as of the date of the lis pendens must file a claim within 60 days after the sale.

In accordance with the Americans With Disabilities Act, persons needing a reasonable accommodation to participate in this proceeding should contact the Clerk of the Circuit Court no later than seven business days prior to the proceeding at the Sarasota County Courthouse. Telephone 941-861-7425 (Sarasota and Venice) or 1-800-955-8770 via Florida Relay Service.

Karen E. Rushing
Attorney for Plaintiff
Edward B. Pritchard
(813) 229-0900 x1309
KASS SHULER, P.A.
P.O. Box 800
Tampa, FL 33601-0800
October 5, 12, 2012 12-3770S

SECOND INSERTION

NOTICE OF SALE PURSUANT TO CHAPTER 45 IN THE CIRCUIT COURT OF THE TWELFTH JUDICIAL CIRCUIT IN AND FOR SARASOTA COUNTY, FLORIDA

CIVIL ACTION
CASE NO.: 2010 CA 009102 NC
DIVISION: C
WELLS FARGO BANK, N.A.,
Plaintiff, vs.
STEPHEN P. SIEG, et al,
Defendants.

NOTICE IS HEREBY GIVEN Pursuant to a Final Judgment of Foreclosure dated September 18, 2012, and entered in Case No. 2010 CA 009102 NC of the Circuit Court of the Twelfth Judicial Circuit in and for Sarasota County, Florida in which Wells Fargo Bank, N.A., is the Plaintiff and Stephen P. Sieg, Fairways and Greens Condominium Association, Inc., are defendants, I will sell to the highest and best bidder for cash in/on the Internet: www.sarasota.realforeclose.com, Sarasota County, Florida at 9:00am on the 23rd day of October, 2012, the following described property as set forth in said Final Judgment of Foreclosure:

UNIT D-2, BUILDING 2, THE FAIRWAYS AND GREENS, PHASE ONE, A CONDOMINIUM ACCORDING TO THE DECLARATION OF CONDOMINIUM RECORDED IN OFFICIAL RECORDS BOOK 1396, PAGE 1521 AND AS AMENDED IN OFFICIAL RECORDS BOOK 1441, PAGE 2127, AND AS PER PLAT THEREOF RECORDED IN CONDOMINIUM BOOK 15, PAGES 16 THROUGH 16B, OF THE PUBLIC RECORDS OF SARASOTA COUNTY, FLORIDA, TOGETHER WITH AN UNDIVIDED INTEREST IN THE COMMON ELEMENTS APPURTENANT THERETO. A/K/A 3300 BENEVA RD., UNIT 224, SARASOTA FL 34232-4574

Any person claiming an interest in the surplus from the sale, if any, other than the property owner as of the date of the Lis Pendens, must file a claim within 60 days after the sale.

In accordance with the Americans With Disabilities Act, persons needing a reasonable accommodation to participate in this proceeding should contact the Clerk of the Circuit Court no later than seven business days prior to the proceeding at the Sarasota County Courthouse. Telephone 941-861-7425 (Sarasota and Venice) or 1-800-955-8770 via Florida Relay Service.

Albertelli Law
Attorney for Plaintiff
P.O. Box 23028
Tampa, FL 33623
(813) 221-4743
(813) 221-9171 facsimile
eService:
servealaw@albertellilaw.com
CH - 10-50643
October 5, 12, 2012 12-3761S

SECOND INSERTION

NOTICE OF SALE IN THE CIRCUIT COURT OF THE TWELFTH JUDICIAL CIRCUIT IN AND FOR SARASOTA COUNTY, FLORIDA

CIVIL DIVISION
Case #: 2008-CA-013736-NC
DIVISION: C
U.S. Bank National Association, as Indenture Trustee of the HomeBanc Mortgage Trust 2005-1
Plaintiff, -vs.-
Joshua D. Wynne a/k/a Joshua Wynne and Charlotte M. Wynne a/k/a Michelle Wynne, Husband and Wife; Regions Bank; United States of America Department of Treasury
Defendant(s).

NOTICE IS HEREBY GIVEN pursuant to an Order of Final Judgment of Foreclosure dated September 24, 2012, entered in Civil Case No. 2008-CA-013736-NC of the Circuit Court of the 12th Judicial Circuit in and for Sarasota County, Florida, wherein U.S. Bank National Association, as Indenture Trustee of the HomeBanc Mortgage Trust 2005-1, Plaintiff and Joshua D. Wynne a/k/a Joshua Wynne and Charlotte M. Wynne a/k/a Michelle Wynne, Husband and Wife are defendant(s), I, Clerk of Court, KAREN E. RUSHING, will sell to the highest and best bidder for cash VIA THE INTERNET AT WWW.SARASOTA.REALFORECLOSE.COM, AT 9:00 A.M. on October 29, 2012, the following described property as set forth in said Final Judgment, to-wit:

THE WEST 1/2 OF THE SOUTH 240 FEET OF THE EAST 414.86 FEET OF THE SOUTHWEST 1/4 OF THE NORTHWEST 1/4 OF THE NORTHEAST 1/4 SECTION 10, TOWNSHIP 36 SOUTH, RANGE 18 EAST, SARASOTA COUNTY, FLORIDA, LESS AND EXCEPT ROAD RIGHT OF WAY.

ANY PERSON CLAIMING AN INTEREST IN THE SURPLUS FROM THE SALE, IF ANY, OTHER THAN THE PROPERTY OWNER AS OF THE DATE OF THE LIS PENDENS MUST FILE A CLAIM WITHIN 60 DAYS AFTER THE SALE.

In accordance with the Americans With Disabilities Act, persons needing a reasonable accommodation to participate in this proceeding should contact the Clerk of the Circuit Court no later than seven business days prior to the proceeding at the Sarasota County Courthouse. Telephone 941-861-7425 (Sarasota and Venice) or 1-800-955-8770 via Florida Relay Service.

By: Ella Roberts, Esquire
FL Bar # 75943

SHAPIRO, FISHMAN & GACHÉ, LLP
Attorneys for Plaintiff
2424 North Federal Highway,
Suite 360
Boca Raton, Florida 33431
Telephone: (561) 998-6700
Fax: (561) 998-6707
08-106646 FC01 W50
October 5, 12, 2012 12-3855S

SECOND INSERTION

NOTICE OF FORECLOSURE SALE IN THE CIRCUIT COURT OF THE 12TH JUDICIAL CIRCUIT, IN AND FOR SARASOTA COUNTY, FLORIDA

CIVIL DIVISION
CASE NO. 2009 CA 014828 NC
FANNIE MAE ("FEDERAL NATIONAL MORTGAGE ASSOCIATION")
Plaintiff, vs.
MARY L. SPAIN; et al.,
Defendants.

NOTICE IS HEREBY GIVEN pursuant to a Final Judgment of Foreclosure filed September 18, 2012, and entered in Case No. 2009 CA 014828 NC, of the Circuit Court of the 12th Judicial Circuit in and for SARASOTA County, Florida. FANNIE MAE ("FEDERAL NATIONAL MORTGAGE ASSOCIATION") is Plaintiff and MARY L. SPAIN; UNKNOWN SPOUSE OF MARY L. SPAIN; ANY AND ALL UNKNOWN PARTIES CLAIMING BY, THROUGH, UNDER, AND AGAINST THE HEREIN NAMED INDIVIDUAL DEFENDANT(S) WHO ARE NOT KNOWN TO BE DEAD OR ALIVE, WHETHER SAID UNKNOWN PARTIES MAY CLAIM AN INTEREST AS SPOUSES, HEIRS, DEVISEES, GRANTEEES OR OTHER CLAIMANTS; JOHN DOE; JANE DOE AS UNKNOWN TENANTS IN POSSESSION; GULF GATE EAST HOMEOWNERS ASSOCIATION, INC.; are defendants. The Clerk of Court will sell to the highest and best bidder for cash by electronic sale at: www.sarasota.realforeclose.com, at 9:00 a.m., on the 23rd day of October, 2012, the following described property as set forth in said Final Judgment, to wit:

LOT 20, BLOCK 9, GULF GATE EAST, UNIT NO. 3 ACCORDING TO THE PLAT THEREOF RECORDED IN PLAT BOOK 29, PAGES 17 AND 17A, OF THE PUBLIC RECORDS OF SARASOTA COUNTY, FLORIDA.

A person claiming an interest in the surplus from the sale, if any, other than the property owner as of the date of the lis pendens must file a claim within 60 days after the sale.

In accordance with the Americans With Disabilities Act, persons needing a reasonable accommodation to participate in this proceeding should contact the Clerk of the Circuit Court no later than seven business days prior to the proceeding at the Sarasota County Courthouse. Telephone 941-861-7425 (Sarasota and Venice) or 1-800-955-8770 via Florida Relay Service.

Stacy Robins, Esq.
Fla. Bar No.: 008079

Submitted by:
KAHANE & ASSOCIATES, P.A.
8201 Peters Road, Ste.3000
Plantation, FL 33324
Telephone: (954) 382-3486
Telefacsimile: (954) 382-5380
Designated service email:
notice@kahaneandassociates.com
File No.: 10-19878 LBPS
October 5, 12, 2012 12-3846S

SECOND INSERTION

NOTICE OF FORECLOSURE SALE IN THE CIRCUIT COURT OF THE TWELFTH JUDICIAL CIRCUIT IN AND FOR SARASOTA COUNTY, FLORIDA

GENERAL JURISDICTION DIVISION
CASE NO.: 2012 CA 002036 NC
The Bank of New York Mellon FKA The Bank of New York, as Trustee for the Certificateholders of the CWABS Inc., Asset-Backed Certificates, Series 2006-SD4
Plaintiff, vs.
Joyce Whitlock; et al.,
Defendants.

NOTICE IS HEREBY GIVEN pursuant to a Summary Final Judgment of Foreclosure dated September 24, 2012, entered in Case No. 2012 CA 002036 NC of the Circuit Court of the Twelfth Judicial Circuit, in and for Sarasota County, Florida, wherein The Bank of New York Mellon FKA The Bank of New York, as Trustee for the Certificateholders of the CWABS Inc., Asset-Backed Certificates, Series 2006-SD4 is the Plaintiff and Joyce Whitlock; Donald Whitlock; Unknown Tenant #1; Unknown Tenant #2 are the Defendants, that the clerk of courts will sell to the highest and best bidder for cash by electronic sale at www.sarasota.realforeclose.com, beginning at 9:00 AM on the 01 day of November, 2012, the following described property as set forth in said Final Judgment, to wit:

FROM A CONCRETE MONUMENT AT THE INTERSECTION OF THE NORTH LINE OF THE NW 1/4 OF THE NE 1/4 OF SECTION 12, TOWNSHIP 36 SOUTH, RANGE 17 EAST, SARASOTA COUNTY, FLORIDA, AND THE EASTERLY LINE OF THE 66 FOOT RIGHT-OF-WAY OF TAMIAMI TRAIL (U.S. 41) RUN SOUTH-EASTERLY ALONG EASTERLY LINE OF TAMIAMI TRAIL 391.6 FEET TO THE SOUTH LINE OF A 25 FOOT STREET; THENCE EASTERLY

ALONG THE SOUTH SIDE OF SAID STREET 755.2 FEET TO AN IRON PIPE WHICH IS THE POINT OF BEGINNING; THENCE SOUTH 100 FEET TO AN IRON PIPE; THENCE 118.2 FEET TO A CONCRETE MONUMENT; THENCE NORTH 100 FEET TO A CONCRETE MONUMENT; THENCE WEST 119 FEET TO THE POINT OF BEGINNING; TOGETHER WITH AN EASEMENT FOR INGRESS AND EGRESS OVER A STRIP OF LAND 25 FEET WIDE LYING IMMEDIATELY NORTH OF THE ABOVE-DESCRIBED PROPERTY EXTENDED FROM THE TAMIAMI TRAIL TO TH EASTERLY BOUNDARY OF SAID PROPERTY

ANY PERSON CLAIMING AN INTEREST IN THE SURPLUS FROM THE SALE, IF ANY, OTHER THAN THE PROPERTY OWNER AS OF THE DATE OF THE LIS PENDENS, MUST FILE A CLAIM WITHIN 60 DAYS AFTER THE SALE.

In accordance with the Americans With Disabilities Act, persons needing a reasonable accommodation to participate in this proceeding should contact the Clerk of the Circuit Court no later than seven business days prior to the proceeding at the Sarasota County Courthouse. Telephone 941-861-7425 (Sarasota and Venice) or 1-800-955-8770 via Florida Relay Service.

Dated this 27th day of September, 2012.

By: Jessica Jo Fagen, Esq.
Florida Bar No. 50668
BROCK & SCOTT, PLLC
Attorney for Plaintiff
1501 N.W. 49th Street, Suite 200
Ft. Lauderdale, FL 33309
Phone: (954) 618-6955, ext. 6105
Fax: (954) 618-6954
FLCourtDocs@brockandscott.com
12-F00968
October 5, 12, 2012 12-3762S

SECOND INSERTION

NOTICE OF FORECLOSURE SALE IN THE CIRCUIT COURT OF THE 12TH JUDICIAL CIRCUIT, IN AND FOR SARASOTA COUNTY, FLORIDA

CIVIL DIVISION:
CASE NO.: 2009 CA 006131 NC
COUNTRYWIDE HOME LOANS SERVICING LP,
Plaintiff, vs.
SANDY LEAL A/K/A SANDY ANN LEAL; CROCKERS LAKE COMMUNITY ASSOCIATION, INC.; PALMER RANCH MASTER PROPERTY OWNERS ASSOCIATION, INC.; VINTAGE GRAND CONDOMINIUM ASSOCIATION, INC.; UNKNOWN SPOUSE OF SANDY LEAL A/K/A SANDY ANN LEAL; UNKNOWN TENANT (S) IN POSSESSION OF THE SUBJECT PROPERTY,
Defendant(s).

NOTICE IS HEREBY GIVEN pursuant to Final Judgment of Foreclosure dated the 18th day of September 2012 and entered in Case No. 2009 CA 006131 NC, of the Circuit Court of the 12TH Judicial Circuit in and for Sarasota County, Florida, wherein BANK OF AMERICA, N.A., SUCCESSOR BY MERGER TO BAC HOME LOANS SERVICING, LP FKA COUNTRYWIDE HOME LOANS SERVICING is the Plaintiff and SANDY LEAL AKA SANDY ANN LEAL, CROCKERS LAKE COMMUNITY ASSOCIATION, INC., PALMER RANCH MASTER PROPERTY OWNERS ASSOCIATION, INC., VINTAGE GRAND CONDOMINIUM ASSOCIATION, INC., UNKNOWN SPOUSE OF SANDY LEAL AKA SANDY ANN LEAL NKA SERGIO GARCIA, UNKNOWN TENANT (S) NKA MUHAMMAD IAHHIM and UNKNOWN TENANT (S) IN POSSESSION OF THE SUBJECT PROPERTY are defendants. The Clerk of this Court shall sell to the highest and best bidder for cash electronically at www.sarasota.realforeclose.com at, 9:00 AM on the 25th day of October

2012 the following described property as set forth in said Final Judgment, to wit:

UNIT 28, BUILDING 5, VINTAGE GRAND CONDOMINIUM, ACCORDING TO THE DECLARATION OF CONDOMINIUM RECORDED IN OFFICIAL RECORDS INSTRUMENT NO. 2005281688, AND AMENDMENTS THERETO, OF THE PUBLIC RECORDS OF SARASOTA COUNTY, FLORIDA, TOGETHER WITH AN UNDIVIDED INTEREST IN THE COMMON ELEMENTS APPURTENANT THERETO.

ANY PERSON CLAIMING AN INTEREST IN THE SURPLUS FROM THE SALE, IF ANY, OTHER THAN THE PROPERTY OWNER AS OF THE DATE OF THE LIS PENDENS MUST FILE A CLAIM WITHIN 60 DAYS AFTER THE SALE.

In accordance with the Americans With Disabilities Act, persons needing a reasonable accommodation to participate in this proceeding should contact the Clerk of the Circuit Court no later than seven business days prior to the proceeding at the Sarasota County Courthouse. Telephone 941-861-7425 (Sarasota and Venice) or 1-800-955-8770 via Florida Relay Service.

Dated this 1 day of October, 2012.
Lucetta Pierre-Louis, Esq
Bar Number: 86807

Submitted by:
LAW OFFICES OF
MARSHALL C. WATSON, P.A.
1800 NW 49th Street, Suite 120
Fort Lauderdale, Florida 33309
Telephone: (954) 453-0365
Facsimile: (954) 771-6052
Toll Free: 1-800-441-2438
DESIGNATED PRIMARY E-MAIL
FOR SERVICE PURSUANT TO FLA.
R. JUD. ADMIN 2.516
eservice@marshallwatson.com
09-14807
October 5, 12, 2012 12-3813S

SECOND INSERTION

NOTICE OF FORECLOSURE SALE IN THE CIRCUIT COURT OF THE TWELFTH JUDICIAL CIRCUIT, IN AND FOR SARASOTA COUNTY, FLORIDA

CIVIL ACTION
CASE NO.: 58-2009-CA-003726 NC
DIVISION: A
CHASE HOME FINANCE LLC
SUCCESSOR BY MERGER
TO CHASE MANHATTAN MORTGAGE CORPORATION,
Plaintiff, vs.
JUDITH L. BRAUDE, AS TRUSTEE OF THE REVOCABLE TRUST OF JUDITH L. BRAUDE, et al,
Defendant(s).

NOTICE IS HEREBY GIVEN pursuant to a Final Judgment of Mortgage Foreclosure dated September 24, 2012 and entered in Case No. 58-2009-CA-003726 NC of the Circuit Court of the TWELFTH Judicial Circuit in and for SARASOTA County, Florida wherein JPMORGAN CHASE BANK, NATIONAL ASSOCIATION, SUCCESSOR BY MERGER TO CHASE HOME FINANCE LLC, is the Plaintiff and JUDITH L. BRAUDE, AS TRUSTEE OF THE REVOCABLE TRUST OF JUDITH L. BRAUDE; THE UNKNOWN BENEFICIARIES OF THE REVOCABLE TRUST OF JUDITH L. BRAUDE; JUDITH L. BRAUDE; ANY AND ALL UNKNOWN PARTIES CLAIMING BY, THROUGH, UNDER, AND AGAINST THE HEREIN NAMED INDIVIDUAL DEFENDANT(S) WHO ARE NOT KNOWN TO BE DEAD OR ALIVE, WHETHER SAID UNKNOWN PARTIES MAY CLAIM AN INTEREST AS SPOUSE, HEIRS, DEVISEES, GRANTEEES, OR OTHER CLAIMANTS; THIRD FEDERAL SAVINGS AND LOAN ASSOCIATION OF CLEVELAND; GULFSTREAM TOWERS ASSOCIATION, INC., A CONDOMINIUM; are the Defendants, The Clerk will sell to the

highest and best bidder for cash at WWW.SARASOTA.REALFORECLOSE.COM at 9:00AM, on the 29th day of October, 2012, the following described property as set forth in said Final Judgment:

UNIT 707, GULFSTREAM TOWERS, A CONDOMINIUM ACCORDING TO THE DECLARATION OF CONDOMINIUM RECORDED IN O.R. BOOK 505, PAGE 53, AS AMENDED AND AS PER PLAT THEREOF RECORDED IN CONDOMINIUM BOOK 1, PAGES 13, 14, 15, 16 AND 17, OF THE PUBLIC RECORDS OF SARASOTA COUNTY, FLORIDA. TOGETHER WITH ANY AND ALL AMENDMENTS TO THE DECLARATION AND ANY UNDIVIDED INTEREST IN THE COMMON ELEMENTS OR APPURTENANCES THERETO.

A/K/A 33 S GULFSTREAM AVENUE #707, SARASOTA, FL 342360000

Any person claiming an interest in the surplus from the sale, if any, other than the property owner as of the date of the Lis Pendens must file a claim within sixty (60) days after the sale.

In accordance with the Americans With Disabilities Act, persons needing a reasonable accommodation to participate in this proceeding should contact the Clerk of the Circuit Court no later than seven business days prior to the proceeding at the Sarasota County Courthouse. Telephone 941-861-7425 (Sarasota and Venice) or 1-800-955-8770 via Florida Relay Service.

By: Shilpini Vora Burris
Florida Bar No. 27205
RONALD R WOLFE & ASSOCIATES, P.L.
P.O. Box 25018
Tampa, Florida 33622-5018
(813) 251-4766
F09023544
October 5, 12, 2012 12-3789S

SECOND INSERTION

NOTICE OF SALE IN THE CIRCUIT COURT OF THE TWELFTH JUDICIAL CIRCUIT IN AND FOR SARASOTA COUNTY, FLORIDA
CASE NO. 2011 CA 002530 NC
MIDFIRST BANK
Plaintiff, v.
TIMOTHY MARTIN; SVETLANA MARTIN; UNKNOWN TENANT 1; UNKNOWN TENANT 2; AND ALL UNKNOWN PARTIES CLAIMING BY, THROUGH, UNDER OR AGAINST THE ABOVE NAMED DEFENDANT(S), WHO (IS/ARE) NOT KNOWN TO BE DEAD OR ALIVE, WHETHER SAID UNKNOWN PARTIES CLAIM AS HEIRS, DEVISEES, GRANTEES, ASSIGNEES, LIENORS, CREDITORS, TRUSTEES, SPOUSES, OR OTHER CLAIMANTS;
Defendants.

Notice is hereby given that, pursuant to the Summary Final Judgment of Foreclosure entered on September 24, 2012, in this cause, in the Circuit Court of Sarasota County, Florida, the clerk shall sell the property situated in Sarasota County, Florida, described as:

LOT 1450, LAKE SARASOTA, UNIT 16, AS PER PLAT THEREOF RECORDED IN PLAT BOOK 9, PAGE 22, OF THE PUBLIC RECORDS OF SARASOTA COUNTY, FLORIDA
a/k/a 3930 CHAUCER LANE, SARASOTA, FL 34241

at public sale, to the highest and best bidder, for cash, online at www.sarasota.realforeclose.com, Sarasota County, Florida, on October 31, 2012 at 09:00 AM.

Any person claiming an interest in the surplus from the sale, if any, other than the property owner as of the date of the lis pendens must file a claim within 60 days after the sale.

In accordance with the Americans With Disabilities Act, persons needing a reasonable accommodation to participate in this proceeding should contact the Clerk of the Circuit Court no later than seven business days prior to the proceeding at the Sarasota County Courthouse. Telephone 941-861-7425 (Sarasota and Venice) or 1-800-955-8770 via Florida Relay Service.

Dated at St. Petersburg, Florida, this 2 day of October, 2012.

Karen E. Rushing
Clerk of the Circuit Court
s\ Tara M. McDonald, Esquire
Tara M. McDonald, Esquire
Florida Bar No. 43941

DOUGLAS C. ZAHM, P.A.
12425 28th Street North, Suite 200
St. Petersburg, FL 33716
Telephone No. (727) 536-4911
Fax No. (727) 539-1094
Attorney for Plaintiff
111110126
October 5, 12, 2012 12-3862S

SECOND INSERTION

NOTICE OF RESCHEDULED FORECLOSURE SALE IN THE CIRCUIT COURT OF THE TWELFTH JUDICIAL CIRCUIT, IN AND FOR SARASOTA COUNTY, FLORIDA
CIVIL ACTION
CASE NO.: 2011-CA-003052-NC
DIVISION: A
WELLS FARGO BANK, NA
DBA AMERICAS SERVICING COMPANY,
Plaintiff, vs.
OREN SCHNEIDEROVITCH, et al,
Defendant(s).

NOTICE IS HEREBY GIVEN pursuant to an Order Rescheduling Foreclosure Sale dated September 25, 2012 and entered in Case NO. 2011-CA-003052-NC of the Circuit Court of the TWELFTH Judicial Circuit in and for SARASOTA County, Florida wherein WELLS FARGO BANK, NA DBA AMERICAS SERVICING COMPANY, is the Plaintiff and OREN SCHNEIDEROVITCH; THE UNKNOWN SPOUSE OF OREN SCHNEIDEROVITCH N/K/A DANIEL SCHNEIDEROVITCH; AMERIFIRST FINANCIAL CORPORATION; CITY OF NORTH PORT; are the Defendants, The Clerk will sell to the highest and best bidder for cash at WWW.SARASOTA.REALFORECLOSE.COM at 9:00AM, on 10/25/2012, the following described property as set forth in said Final Judgment:

LOT 20, BLOCK 324, 5TH ADDITION TO PORT CHARLOTTE SUBDIVISION, A SUBDIVISION ACCORDING TO THE PLAT THEREOF, RECORDED IN PLAT BOOK 11, PAGES 33, 33A THROUGH 33R, INCLUSIVE, OF THE PUBLIC RECORDS OF SARASOTA COUNTY, FLORIDA.

A/K/A 2623 N ASHLAND LANE, NORTH PORT, FL 34286

Any person claiming an interest in the surplus from the sale, if any, other than the property owner as of the date of the Lis Pendens must file a claim within sixty (60) days after the sale.

In accordance with the Americans With Disabilities Act, persons needing a reasonable accommodation to participate in this proceeding should contact the Clerk of the Circuit Court no later than seven business days prior to the proceeding at the Sarasota County Courthouse. Telephone 941-861-7425 (Sarasota and Venice) or 1-800-955-8770 via Florida Relay Service.

By: Ivan D. Ivanov
Florida Bar No. 39023

RONALD R WOLFE & ASSOCIATES, P.L.
P.O. Box 25018
Tampa, Florida 33622-5018
(813) 251-4766
F11014329
October 5, 12, 2012 12-3793S

SECOND INSERTION

NOTICE OF FORECLOSURE SALE IN THE CIRCUIT COURT OF THE TWELFTH JUDICIAL CIRCUIT, IN AND FOR SARASOTA COUNTY, FLORIDA
CIVIL ACTION
CASE NO.: 2008 CA 020214 NC
DIVISION: A
CHASE HOME FINANCE LLC
SUCCESSOR BY MERGER
TO CHASE MANHATTAN
MORTGAGE CORPORATION,
Plaintiff, vs.
THOMAS M. HEINZEL, et al,
Defendant(s).

NOTICE IS HEREBY GIVEN pursuant to a Final Judgment of Mortgage Foreclosure dated September 24, 2012 and entered in Case No. 2008 CA 020214 NC of the Circuit Court of the TWELFTH Judicial Circuit in and for SARASOTA County, Florida wherein JPMORGAN CHASE BANK, NATIONAL ASSOCIATION, SUCCESSOR BY MERGER TO CHASE HOME FINANCE LLC, is the Plaintiff and THOMAS M. HEINZEL; KELLY J. HEINZEL; AMERICAN GENERAL HOME EQUITY, INC.; are the Defendants, The Clerk will sell to the highest and best bidder for cash at WWW.SARASOTA.REALFORECLOSE.COM at 9:00AM, on the 29th day of October, 2012, the following described property as set forth in said Final Judgment:

LOT 857, 858, AND THE SOUTHWESTERLY 1/2 OF LOT 859, SOUTH VENICE, UNIT NO. 3, AS PER PLAT THEREOF, RECORDED IN PLAT BOOK 6, PAGE 31, PUBLIC RECORDS OF SARASOTA COUNTY, FLORIDA

A/K/A 315 SOUTHLAND ROAD, VENICE, FL 342930000

Any person claiming an interest in the surplus from the sale, if any, other than the property owner as of the date of the Lis Pendens must file a claim within sixty (60) days after the sale.

In accordance with the Americans With Disabilities Act, persons needing a reasonable accommodation to participate in this proceeding should contact the Clerk of the Circuit Court no later than seven business days prior to the proceeding at the Sarasota County Courthouse. Telephone 941-861-7425 (Sarasota and Venice) or 1-800-955-8770 via Florida Relay Service.

By: Salina B. Klinghammer
Florida Bar No. 86041

RONALD R WOLFE & ASSOCIATES, P.L.
P.O. Box 25018
Tampa, Florida 33622-5018
(813) 251-4766
F08108624
October 5, 12, 2012 12-3790S

SECOND INSERTION

NOTICE OF SALE IN THE CIRCUIT COURT OF THE TWELFTH JUDICIAL CIRCUIT OF THE STATE OF FLORIDA, IN AND FOR SARASOTA COUNTY CIVIL DIVISION
CASE NO. 2009 CA 004668 NC
LIBERTY SAVINGS BANK, FSB,
Plaintiff, vs.
BRYAN E. COOPER A/K/A BRYAN COOPER; UNKNOWN SPOUSE OF BRYAN E. COOPER A/K/A BRYAN COPPER; IF LIVING, INCLUDING ANY UNKNOWN SPOUSE OF SAID DEFENDANT(S), IF REMARRIED, AND IF DECEASED, THE RESPECTIVE UNKNOWN HEIRS, DEVISEES, GRANTEES, ASSIGNEES, CREDITORS, LIENORS, AND TRUSTEES, AND ALL OTHER PERSONS CLAIMING BY, THROUGH, UNDER OR AGAINST THE NAMED DEFENDANT(S); LIBERTY SAVINGS BANK, FSB; JOHN DOE; JANE DOE;
Defendant(s)

Notice is hereby given that, pursuant to a Final Summary Judgment of Foreclosure entered on 09/10/2012 in the above-styled cause, in the Circuit Court of Sarasota County, Florida, the office of Karen E. Rushing clerk of the circuit court will sell the property situate in Sarasota County, Florida, described as:

LOT 15, BLOCK 92, SOUTH GATE, UNIT NO 23, ACCORDING TO THE PLAT THEREOF, AS RECORDED IN PLAT BOOK 10, PAGE 22, OF THE PUBLIC RECORDS OF SARASOTA COUNTY, FLORIDA.

at public sale, to the highest and best bidder, for cash, www.sarasota.realforeclose.com at 9:00 o'clock, A.M., on October 18, 2012

Any person claiming an interest in the surplus from the sale, if any, other than the property owner as of the date of the lis pendens, must file a claim within 60 days after the sale.

In accordance with the Americans With Disabilities Act, persons needing a reasonable accommodation to participate in this proceeding should contact the Clerk of the Circuit Court no later than seven business days prior to the proceeding at the Sarasota County Courthouse. Telephone 941-861-7425 (Sarasota and Venice) or 1-800-955-8770 via Florida Relay Service.
Date: 09/27/2012

ATTORNEY FOR PLAINTIFF
By Craig T Smith
Florida Bar # 20315

THIS INSTRUMENT
PREPARED BY:
LAW OFFICES OF
DANIEL C. CONSUEGRA
9204 King Palm Drive
Tampa, Florida 33619-1328
Phone: 813-915-8660
Attorneys for Plaintiff
October 5, 12, 2012 12-3764S

SECOND INSERTION

NOTICE OF FORECLOSURE SALE IN THE CIRCUIT COURT OF THE TWELFTH JUDICIAL CIRCUIT IN AND FOR SARASOTA COUNTY, FLORIDA
CIVIL ACTION
CASE NO.: 2011-CA-000289-NC
DIVISION: A
WELLS FARGO BANK, NA,
Plaintiff, vs.
SIMONE M. MICALA/K/A
SIMONE M. BUDD A/K/A
SIMONE BUDD, et al,
Defendant(s).

NOTICE IS HEREBY GIVEN pursuant to a Final Judgment of Mortgage Foreclosure dated September 24, 2012 and entered in Case No. 2011-CA-000289-NC of the Circuit Court of the TWELFTH Judicial Circuit in and for SARASOTA County, Florida wherein WELLS FARGO BANK, NA is the Plaintiff and SIMONE M. MICALA A/K/A SIMONE M. BUDD A/K/A SIMONE BUDD; THE UNKNOWN SPOUSE OF SIMONE M. MICALA A/K/A SIMONE M. BUDD A/K/A SIMONE BUDD N/K/A CHRIS BUDD; WELLS FARGO BANK, NATIONAL ASSOCIATION, AS SUCCESSOR BY MERGER TO WACHOVIA BANK, NATIONAL ASSOCIATION; are the Defendants, The Clerk will sell to the highest and best bidder for cash at WWW.SARASOTA.REALFORECLOSE.COM at 9:00AM, on the 31st day of October, 2012, the following described property as set forth in said Final Judgment:

LOT15,BLOCK1922,41STADDITION TO PORT CHARLOTTE SUBDIVISION, ACCORDING TO THE PLAT THEREOF RECORDED IN PLAT BOOK 16, PAGE 42, OF THE PUBLIC RECORDS OF SARASOTA COUNTY,FLORIDA.

A/K/A 4827 CHICOPA STREET, NORTH PORT, FL 34287

Any person claiming an interest in the surplus from the sale, if any, other than the property owner as of the date of the Lis Pendens must file a claim within sixty (60) days after the sale.

In accordance with the Americans With Disabilities Act, persons needing a reasonable accommodation to participate in this proceeding should contact the Clerk of the Circuit Court no later than seven business days prior to the proceeding at the Sarasota County Courthouse. Telephone 941-861-7425 (Sarasota and Venice) or 1-800-955-8770 via Florida Relay Service.

By: Stephen Peterson
Florida Bar No. 0091587

RONALD R WOLFE & ASSOCIATES, P.L.
P.O. Box 25018
Tampa, Florida 33622-5018
(813) 251-4766
F1012464
October 5, 12, 2012 12-3859S

SECOND INSERTION

NOTICE OF RESCHEDULED FORECLOSURE SALE IN THE CIRCUIT COURT OF THE TWELFTH JUDICIAL CIRCUIT IN AND FOR SARASOTA COUNTY, FLORIDA
CIVIL ACTION
CASE NO.: 58-2011-CA-007172 NC
DIVISION: C
SUNTRUST MORTGAGE, INC.,
Plaintiff, vs.
DEJAN LAZIC, et al,
Defendant(s).

NOTICE IS HEREBY GIVEN pursuant to an Order Rescheduling Foreclosure Sale dated September 25, 2012 and entered in Case NO. 58-2011-CA-007172 NC of the Circuit Court of the TWELFTH Judicial Circuit in and for SARASOTA County, Florida wherein SUNTRUST MORTGAGE, INC., is the Plaintiff and DEJAN LAZIC; ANA LAZIC; MILENKO LAZIC; THE UNKNOWN SPOUSE OF MILENKO LAZIC N/K/A GORDANA LAZIC; MORTGAGE ELECTRONIC REGISTRATION SYSTEMS, INCORPORATED, AS NOMINEE FOR SUNTRUST MORTGAGE, INC.; are the Defendants, The Clerk will sell to the highest and best bidder for cash at WWW.SARASOTA.REALFORECLOSE.COM at 9:00AM, on 10/26/2012, the following described property as set forth in said Final Judgment:

LOT 37, BLOCK 937, SECOND REPLAT IN FIFTEENTH ADDITION TO PORT CHARLOTTE SUBDIVISION, ACCORDING TO THE PLAT THEREOF RECORDED IN PLAT BOOK 19, PAGES 3, 3A THROUGH 3C, INCLUSIVE, OF THE PUBLIC RECORDS OF SARASOTA COUNTY, FLORIDA

A/K/A 8821 PICKWICK ROAD, NORTH PORT, FL 34287

Any person claiming an interest in the surplus from the sale, if any, other than the property owner as of the date of the Lis Pendens must file a claim within sixty (60) days after the sale.

In accordance with the Americans With Disabilities Act, persons needing a reasonable accommodation to participate in this proceeding should contact the Clerk of the Circuit Court no later than seven business days prior to the proceeding at the Sarasota County Courthouse. Telephone 941-861-7425 (Sarasota and Venice) or 1-800-955-8770 via Florida Relay Service.

By: Luke Kiel
Florida Bar No. Pending

RONALD R WOLFE & ASSOCIATES, P.L.
P.O. Box 25018
Tampa, Florida 33622-5018
(813) 251-4766
F11015677
October 5, 12, 2012 12-3858S

SECOND INSERTION

AMENDED NOTICE OF FORECLOSURE SALE IN THE CIRCUIT COURT IN AND FOR SARASOTA COUNTY, FLORIDA
CASE NO. 2007-CA-10315-SC-H
BANK OF NEW YORK
AS TRUSTEE FOR THE
CERTIFICATEHOLDERS CWALT,
INC. ALTERNATIVE LOAN
TRUST 2006-OA12, MORTGAGE
PASS-THROUGH CERTIFICATES,
SERIES 2006-OA12
Plaintiff, vs.

TAMARA A. PATZER A/K/A TAMARA PATZER; MORTGAGE ELECTRONIC REGISTRATION SYSTEMS, INC., AS NOMINEE FOR AMERICAS WHOLESALE LENDER, AND any unknown heirs, devisees, grantees, creditors, and other unknown persons or unknown spouses claiming by, through and under any of the above-named Defendants,
Defendants.

NOTICE is hereby given that the Clerk of the Circuit Court of Sarasota County, Florida, will on the 24th day of October 2012, at 9:00am www.sarasota.realforeclose.com in accordance with Florida Statutes, offer for sale and sell at public outcry to the highest and best bidder for cash, the following-described property situate in Sarasota County, Florida:

Lot 368 less the Westerly 528.16 feet thereof; Lot 369, less the Northerly 129.0 feet of the Westerly 675.36 feet thereof, and the East one-half of Lot 370, ENGLEWOOD GARDENS, according to the plat thereof recorded in Plat Book 4, Pages 28 and 28A, Public Records of Sarasota County, Florida, Subject to an easement to use a 50 by 147.20

foot parcel for yard and drain field purpose adjacent to the existing house of Lot 369, Englewood Gardens, so long as said house continues to exist, said parcel described as the South 50 feet of the West 675.36 feet of Lot 368, ENGLEWOOD GARDENS, as per Plat Book 4, Pages 28 and 28A, Public Records of Sarasota County, Florida, less the Westerly 528.16 feet thereof, Sarasota County Records.

pursuant to the Final Judgment entered in a case pending in said Court, the style of which is indicated above.

Any person or entity claiming an interest in the surplus, if any, resulting from the foreclosure sale, other than the property owner as of the date of the Lis Pendens, must file a claim on same with the Clerk of Court within 60 days after the foreclosure sale.

In accordance with the Americans With Disabilities Act, persons needing a reasonable accommodation to participate in this proceeding should contact the Clerk of the Circuit Court no later than seven business days prior to the proceeding at the Sarasota County Courthouse. Telephone 941-861-7425 (Sarasota and Venice) or 1-800-955-8770 via Florida Relay Service.

DATED this 26 day of September, 2012.

Mark William Hernandez, Esquire
BUTLER & HOSCH, P.A.
3185 South Conway Road, Suite E
Orlando, Florida 32812
Telephone: (407) 381-5200
Fax: (407) 381-5577
Florida Bar No: 0069051
Service Emails:
mh69051@butlerandhosch.com
FLPleadings@butlerandhosch.com
B&H # 252195
October 5, 12, 2012 12-3767S

SECOND INSERTION

NOTICE OF FORECLOSURE SALE IN THE CIRCUIT COURT OF THE 12TH JUDICIAL CIRCUIT, IN AND FOR SARASOTA COUNTY, FLORIDA
CIVIL DIVISION:

CASE NO.: 2009 CA 007862 NC
THE BANK OF NEW YORK
MELLON TRUST COMPANY,
NATIONAL ASSOCIATION FKA
THE BANK OF NEW YORK
TRUST COMPANY, N.A. AS
SUCCESSOR TO JPMORGAN
CHASE BANK N.A. AS TRUSTEE
FOR RAMP 2003RS10,
Plaintiff, vs.
ELIAZER SALGADO A/K/A
ELIAZOR SALGADO;
CITIFINANCIAL EQUITY
SERVICES, INC.; EDILIA LOPEZ;
UNKNOWN TENANT(S); IN
POSSESSION OF THE SUBJECT
PROPERTY,
Defendant(s).

NOTICE IS HEREBY GIVEN pursuant to Final Judgment of Foreclosure dated the 18th day of September 2012 and entered in Case No. 2009 CA 007862 NC, of the Circuit Court of the 12TH Judicial Circuit in and for Sarasota County, Florida, wherein THE BANK OF NEW YORK MELLON TRUST COMPANY, NATIONAL ASSOCIATION FKA THE BANK OF NEW YORK TRUST COMPANY, N.A. AS SUCCESSOR TO JPMORGAN CHASE BANK N.A. AS TRUSTEE FOR RAMP 2003RS10 is the Plaintiff and ELIAZER SALGADO A/K/A ELIAZOR SALGADO, CITIFINANCIAL EQUITY SERVICES, INC., EDILIA LOPEZ, UNKNOWN TENANT(S) and UNKNOWN TENANT(S) IN POSSESSION OF THE SUBJECT PROPERTY are defendants. The Clerk of this Court shall sell to the highest and best bidder for cash electronically at www.

sarasota.realforeclose.com at, 9:00 AM on the 25th day of October 2012, the following described property as set forth in said Final Judgment, to wit:

LOT 24, BLOCK 106, 7TH ADDITION TO PORT CHARLOTTE SUBDIVISION, ACCORDING TO THE PLAT THEREOF, RECORDED IN PLAT BOOK 12, PAGE 19, OF THE PUBLIC RECORDS OF SARASOTA COUNTY, FLORIDA.

ANY PERSON CLAIMING AN INTEREST IN THE SURPLUS FROM THE SALE, IF ANY, OTHER THAN THE PROPERTY OWNER AS OF THE DATE OF THE LIS PENDENS MUST FILE A CLAIM WITHIN 60 DAYS AFTER THE SALE.

In accordance with the Americans With Disabilities Act, persons needing a reasonable accommodation to participate in this proceeding should contact the Clerk of the Circuit Court no later than seven business days prior to the proceeding at the Sarasota County Courthouse. Telephone 941-861-7425 (Sarasota and Venice) or 1-800-955-8770 via Florida Relay Service.

Dated this 28 day of September, 2012.

By: Michelle Zelina, Esq.
Bar Number: 85613

Submitted by:
LAW OFFICES OF
MARSHALL C. WATSON, P.A.
1800 NW 49th Street, Suite 120
Fort Lauderdale, Florida 33309
Telephone: (954) 453-0365
Facsimile: (954) 771-6052
Toll Free: 1-800-441-2438
DESIGNATED PRIMARY E-MAIL FOR SERVICE PURSUANT TO FLA. R. JUD. ADMIN 2.516
eservice@marshallwatson.com
09-27716
October 5, 12, 2012 12-3808S

SECOND INSERTION

RE-NOTICE OF FORECLOSURE SALE IN THE CIRCUIT COURT OF THE 12TH JUDICIAL CIRCUIT, IN AND FOR SARASOTA COUNTY, FLORIDA
CIVIL DIVISION:
CASE NO.: 09-09103
FEDERAL NATIONAL
MORTGAGE ASSOCIATION,
Plaintiff, vs.

SYLVIA R KELLY; AMERICAN EXPRESS CENTURION BANK; CITIBANK (SOUTH DAKOTA) N.A.; DODGE ENTERPRISE, INC.; FIA CARD SERVICES, N.A., F/K/A BANK OF AMERICA; MJRA CORPORATION; UNKNOWN SPOUSE OF LIZANNE VENETTA; UNKNOWN SPOUSE OF SYLVIA R KELLY; WHISPERING OAKS OWNERS' ASSOCIATION, INC.; LIZANNE VENETTA; UNKNOWN TENANT(S); IN POSSESSION OF THE SUBJECT PROPERTY,
Defendants.

NOTICE IS HEREBY GIVEN pursuant to an Order Rescheduling Foreclosure Sale dated the 20 day of September, 2012, and entered in Case No. 09-09103, of the Circuit Court of the 12TH Judicial Circuit in and for Sarasota County, Florida, wherein FEDERAL NATIONAL MORTGAGE ASSOCIATION is the Plaintiff and SYLVIA R KELLY; AMERICAN EXPRESS CENTURION BANK; CITIBANK (SOUTH DAKOTA) N.A.; DODGE ENTERPRISE, INC.; FIA CARD SERVICES, N.A., F/K/A BANK OF AMERICA; MJRA CORPORATION; UNKNOWN SPOUSE OF SYLVIA R KELLY; WHISPERING OAKS OWNERS' ASSOCIATION, INC.; LIZANNE VENETTA; UNKNOWN TENANT(S); IN POSSESSION OF THE SUBJECT PROPERTY are defendants. The Clerk of this Court

shall sell to the highest and best bidder for cash electronically at www.sarasota.realforeclose.com at, 9:00 AM on the 24th day of October, 2012, the following described property as set forth in said Final Judgment, to wit:

LOT 2 OF WHISPERING OAKS, PHASE 2, ACCORDING TO THE PLAT THEREOF AS RECORDED IN PLAT BOOK 35, PAGE(S) 14 & 14A, OF THE PUBLIC RECORDS OF SARASOTA COUNTY, FLORIDA
ANY PERSON CLAIMING AN INTEREST IN THE SURPLUS FROM THE SALE, IF ANY, OTHER THAN THE PROPERTY OWNER AS OF THE DATE OF THE LIS PENDENS MUST FILE A CLAIM WITHIN 60 DAYS AFTER THE SALE.

In accordance with the Americans With Disabilities Act, persons needing a reasonable accommodation to participate in this proceeding should contact the Clerk of the Circuit Court no later than seven business days prior to the proceeding at the Sarasota County Courthouse. Telephone 941-861-7425 (Sarasota and Venice) or 1-800-955-8770 via Florida Relay Service.

Dated this 1 day of October, 2012.
By: Elisabeth Porter, Esq.
Bar Number: 645648

Submitted by:
LAW OFFICES OF
MARSHALL C. WATSON, P.A.
1800 NW 49th Street, Suite 120
Fort Lauderdale, Florida 33309
Telephone: (954) 453-0365
Facsimile: (954) 771-6052
Toll Free: 1-800-441-2438
DESIGNATED PRIMARY E-MAIL FOR SERVICE PURSUANT TO FLA. R. JUD. ADMIN 2.516
eservice@marshallwatson.com
09-22091
October 5, 12, 2012 12-3833S

SECOND INSERTION

NOTICE OF SALE
IN THE CIRCUIT COURT OF THE
TWELFTH JUDICIAL CIRCUIT IN
AND FOR SARASOTA
COUNTY, FLORIDA
CASE NO. 58-2010-CA-004726
WELLS FARGO BANK, N.A.,
SUCCESSOR BY MERGER TO
WELLS FARGO HOME
MORTGAGE, INC. F/K/A
NORWEST MORTGAGE, INC.
Plaintiff, v.
CHRISTINA M. NICHOLS;
UNKNOWN SPOUSE OF
CHRISTINA M. NICHOLS;
UNKNOWN TENANT 1;
UNKNOWN TENANT 2; AND ALL
UNKNOWN PARTIES CLAIMING
BY, THROUGH, UNDER OR
AGAINST THE ABOVE NAMED
DEFENDANT(S), WHO (IS/
ARE) NOT KNOWN TO BE
DEAD OR ALIVE, WHETHER
SAID UNKNOWN PARTIES
CLAIM AS HEIRS, DEVISEES,
GRANTEES, ASSIGNEES,
LIENORS, CREDITORS,
TRUSTEES, SPOUSES, OR

OTHER CLAIMANTS; CITY
OF SARASOTA, FLORIDA, A
MUNICIPAL CORPORATION
Defendants.
Notice is hereby given that, pursuant to the Summary Final Judgment of Foreclosure entered on September 24, 2012, in this cause, in the Circuit Court of Sarasota County, Florida, the clerk shall sell the property situated in Sarasota County, Florida, described as:
LOT 22 AND THE EAST 21 FEET OF LOT 23, BLOCK "A", JACKSON HIGHLANDS SUBDIVISION, AS PER PLAT THEREOF RECORDED IN PLAT BOOK 1, PAGE 148, OF THE PUBLIC RECORDS OF SARASOTA COUNTY, FLORIDA.
a/k/a 2441 ARAPAHO STREET, SARASOTA, FL 34231
at public sale, to the highest and best bidder, for cash, online at www.sarasota.realforeclose.com , Sarasota County, Florida, on October 30, 2012 at 09:00 AM.
Any person claiming an interest in the surplus from the sale, if any, other

than the property owner as of the date of the lis pendens must file a claim within 60 days after the sale.
In accordance with the Americans With Disabilities Act, persons needing a reasonable accommodation to participate in this proceeding should contact the Clerk of the Circuit Court no later than seven business days prior to the proceeding at the Sarasota County Courthouse. Telephone 941-861-7425 (Sarasota and Venice) or 1-800-955-8770 via Florida Relay Service.
Dated at St. Petersburg, Florida, this 2 day of October, 2012.
Karen E. Rushing
Clerk of the Circuit Court
Tara M. McDonald, Esquire
Tara M. McDonald, Esquire
Florida Bar No. 43941
DOUGLAS C. ZAHM, P.A.
12425 28th Street North, Suite 200
St. Petersburg, FL 33716
Telephone No. (727) 536-4911
Fax No. (727) 539-1094
Attorney for Plaintiff
888100721
October 5, 12, 2012 12-3870S

NOTICE OF FORECLOSURE SALE
IN THE CIRCUIT COURT OF THE
TWELFTH JUDICIAL CIRCUIT
IN AND FOR SARASOTA COUNTY,
FLORIDA
CIVIL DIVISION
CASE NO.: 58-2011-CA-009393-NC
FREEDOM MORTGAGE
CORPORATION
Plaintiff, v.
CHAD E. JOHNSON, et al.,
Defendants,
NOTICE IS HEREBY GIVEN pursuant to a Final Summary Judgment dated September 10, 2012, entered in Civil Case No.: 58-2011-CA-009393-NC, of the Circuit Court of the TWELFTH Judicial Circuit in and for SARASOTA County, Florida, wherein FREEDOM MORTGAGE CORPORATION, is Plaintiff, and CHAD E. JOHNSON; STEFANIE JOHNSON; UNKNOWN TENANT #1; UNKNOWN TENANT#2; ALL OTHER UNKNOWN PARTIES CLAIMING INTERESTS BY, THROUGH, UNDER AND AGAINST A NAMED DEFENDANT(S) WHO ARE NOT

SECOND INSERTION

KNOWN TO BE DEAD OR ALIVE, WHETHER SAME UNKNOWN PARTIES MAY CLAIM AN INTEREST AS SPOUSES, HEIRS, DEVISEES, GRANTEES, OR OTHER CLAIMANTS, are Defendants
KAREN E. RUSHING, the Clerk of Court, shall sell to the highest bidder for cash online at www.sarasota.realforeclose.com at 9:00 a.m. on the 18th day of October, 2012 the following described real property as set forth in said Final Summary Judgment, to wit:
LOT 24, BLOCK 2433, OF 49TH ADDITION TO PORT CHARLOTTE SUBDIVISION, A SUBDIVISION ACCORDING TO THE PLAT THEREOF AS RECORDED IN PLAT BOOK 21, PAGE 1, OF THE PUBLIC RECORDS OF SARASOTA COUNTY, FLORIDA.
If you are a person claiming a right to funds remaining after the sale, you must file a claim with the clerk no later than 60 days after the sale. If you fail to file a claim you will not be entitled to any remaining funds. After 60 days,

only the owner of record as of the date of the lis pendens may claim the surplus.
In accordance with the Americans With Disabilities Act, persons needing a reasonable accommodation to participate in this proceeding should contact the Clerk of the Circuit Court no later than seven business days prior to the proceeding at the Sarasota County Courthouse. Telephone 941-861-7425 (Sarasota and Venice) or 1-800-955-8770 via Florida Relay Service.
Dated this 27th day of September, 2012.
By: Liana R. Hall, Esquire
Fla. Bar No.: 73813
Primary Email:
LHall@erlaw.com
Secondary Email:
ERWParalegal.Sales@erlaw.com
Attorney for Plaintiff:
ELIZABETH R. WELLBORN, P.A.
350 Jim Moran Blvd. Suite 100
Deerfield Beach, FL 33442
Telephone: (954) 354-3544
Facsimile: (954) 354-3545
File # 1131T-01113
October 5, 12, 2012 12-3786S

SECOND INSERTION

NOTICE OF SALE
IN THE CIRCUIT COURT OF THE
TWELFTH JUDICIAL CIRCUIT IN
AND FOR SARASOTA
COUNTY, FLORIDA
CASE NO. 2011 CA 006137 NC
US BANK NATIONAL
ASSOCIATION, AS TRUSTEE
FOR WACHOVIA MORTGAGE
LOAN TRUST, ASSET-BACKED
CERTIFICATES, SERIES
2006-AMN1
Plaintiff, v.
JEFFREY R. RADCLIFFE;
UNKNOWN SPOUSE OF
JEFFREY R. RADCLIFFE;
UNKNOWN TENANT 1;
UNKNOWN TENANT 2; AND ALL
UNKNOWN PARTIES CLAIMING
BY, THROUGH, UNDER OR
AGAINST THE ABOVE NAMED
DEFENDANT(S), WHO (IS/ARE)
NOT KNOWN TO BE DEAD
OR ALIVE, WHETHER SAID
UNKNOWN PARTIES CLAIM AS
HEIRS, DEVISEES, GRANTEES,
ASSIGNEES, LIENORS,
CREDITORS, TRUSTEES,
SPOUSES, OR OTHER

CLAIMANTS; MORTGAGE
ELECTRONIC REGISTRATION
SYSTEMS, INC.
Defendants.
Notice is hereby given that, pursuant to the Summary Final Judgment of Foreclosure entered on September 24, 2012, in this cause, in the Circuit Court of Sarasota County, Florida, the clerk shall sell the property situated in Sarasota County, Florida, described as:
LOT 1, BLOCK 198, 6TH ADDITION TO PORT CHARLOTTE SUBDIVISION, A SUBDIVISION ACCORDING TO THE PLAT THEREOF AS RECORDED IN PLAT BOOK 11, PAGES 34, 34A THROUGH 34G, INCLUSIVE, PUBLIC RECORDS OF SARASOTA COUNTY, FLORIDA.
a/k/a 5420 SISTER TERRACE, NORTH PORT, FL 34286
at public sale, to the highest and best bidder, for cash, online at www.sarasota.realforeclose.com , Sarasota County, Florida, on October 31, 2012 at 09:00 AM.
Any person claiming an interest in the surplus from the sale, if any, other

than the property owner as of the date of the lis pendens must file a claim within 60 days after the sale.
In accordance with the Americans With Disabilities Act, persons needing a reasonable accommodation to participate in this proceeding should contact the Clerk of the Circuit Court no later than seven business days prior to the proceeding at the Sarasota County Courthouse. Telephone 941-861-7425 (Sarasota and Venice) or 1-800-955-8770 via Florida Relay Service.
Dated at St. Petersburg, Florida, this 2 day of October, 2012.
Karen E. Rushing
Clerk of the Circuit Court
Tara M. McDonald, Esquire
Tara M. McDonald, Esquire
Florida Bar No. 43941
DOUGLAS C. ZAHM, P.A.
12425 28th Street North, Suite 200
St. Petersburg, FL 33716
Telephone No. (727) 536-4911
Fax No. (727) 539-1094
Attorney for Plaintiff
88510444
October 5, 12, 2012 12-3869S

NOTICE OF FORECLOSURE SALE
IN THE CIRCUIT COURT OF THE
12TH JUDICIAL CIRCUIT IN
AND FOR SARASOTA COUNTY,
FLORIDA
CIVIL DIVISION:
CASE NO.: 2009 CA 005452 NC
COUNTRYWIDE HOME LOANS
SERVING, L.P.,
Plaintiff, vs.
EDWARD T. CURRY A/K/A
EDWARD CURRY; GAIL
CURRY A/K/A GAIL A. CURRY;
LONGWOOD VILLAS OF
SARASOTA HOMEOWNERS
ASSOCIATION, INC.; REGIONS
BANK F/K/A AMSOUTH BANK;
UNKNOWN TENANT (S) IN
POSSESSION OF THE SUBJECT
PROPERTY,
Defendant(s).
NOTICE IS HEREBY GIVEN pursuant to Final Judgment of Foreclosure dated the 18th day of September 2012 and entered in Case No. 2009 CA 005452 NC, of the Circuit Court of the 12TH Judicial Circuit in and for Sarasota County, Florida, wherein COUNTRYWIDE HOME LOANS SERVIC-

SECOND INSERTION

ING, L.P. is the Plaintiff and EDWARD T. CURRY A/K/A EDWARD CURRY, GAIL CURRY A/K/A GAIL A. CURRY, LONGWOOD VILLAS OF SARASOTA HOMEOWNERS ASSOCIATION, INC., REGIONS BANK F/K/A AMSOUTH BANK and UNKNOWN TENANT(S) IN POSSESSION OF THE SUBJECT PROPERTY are defendants. The Clerk of this Court shall sell to the highest and best bidder for cash electronically at www.sarasota.realforeclose.com at 9:00 AM on the 25th day of October 2012, the following described property as set forth in said Final Judgment, to wit:
LOT 15 OF LONGWOOD VILLAS SUBDIVISION UNIT FIVE, ACCORDING TO THE MAP OR PLAT THEREOF RECORDED IN PLAT BOOK 34, PAGES 27, 27A THROUGH 27B OF THE PUBLIC RECORDS OF SARASOTA COUNTY, FLORIDA.
ANY PERSON CLAIMING AN INTEREST IN THE SURPLUS FROM THE SALE, IF ANY, OTHER THAN THE PROPERTY OWNER AS OF THE DATE OF THE LIS PENDENS

MUST FILE A CLAIM WITHIN 60 DAYS AFTER THE SALE.
In accordance with the Americans With Disabilities Act, persons needing a reasonable accommodation to participate in this proceeding should contact the Clerk of the Circuit Court no later than seven business days prior to the proceeding at the Sarasota County Courthouse. Telephone 941-861-7425 (Sarasota and Venice) or 1-800-955-8770 via Florida Relay Service.
Dated this 01 day of October, 2012.
By: Lucetta Pierre-Louis, Esq.
Bar Number: 86807
Submitted by:
LAW OFFICES OF
MARSHALL C. WATSON, P.A.
1800 NW 49th Street, Suite 120
Fort Lauderdale, Florida 33309
Telephone: (954) 453-0365
Facsimile: (954) 771-6052
Toll Free: 1-800-441-2438
DESIGNATED PRIMARY E-MAIL
FOR SERVICE PURSUANT TO FLA.
R. JUD. ADMIN 2.516
eservice@marshallwatson.com
09-08089
October 5, 12, 2012 12-3809S

SECOND INSERTION

NOTICE OF SALE PURSUANT TO
CHAPTER 45
IN THE CIRCUIT COURT OF THE
TWELFTH JUDICIAL CIRCUIT
IN AND FOR SARASOTA COUNTY,
FLORIDA
CIVIL ACTION
CASE NO.: 2009 CA 016678 NC
DIVISION: A
JPMORGAN CHASE BANK,
NATIONAL ASSOCIATION,
SUCCESSOR IN INTEREST TO
WASHINGTON MUTUAL BANK,
FA,
Plaintiff, vs.
ROBERT O. WILLIAMS, JR., et al,
Defendants.
NOTICE IS HEREBY GIVEN Pursuant to a Final Judgment of Foreclosure dated September 18, 2012, and entered in Case No. 2009 CA 016678 NC of the Circuit Court of the Twelfth Judicial Circuit in and for Sarasota County, Florida in which JPMorgan Chase Bank, National Association, successor in interest to Washington Mutual Bank, FA, is the Plaintiff and Robert O. Williams, Jr., State of Florida, The Unknown Spouse of Robert O. Williams, Jr. n/k/a Michelle Williams, are defendants, I will sell to the highest and best bidder for cash in/on the Internet: www.sarasota.realforeclose.com , Sarasota County, Florida at 9:00am on the 23rd day of October, 2012, the following described property as set forth in said Final Judgment of Foreclosure:
LOTS 14337 AND 14338, SOUTH VENICE, UNIT 55, ACCORDING TO THE PLAT THEREOF AS RECORDED IN PLAT BOOK 7, PAGE 22, OF THE PUBLIC RECORDS OF SARASOTA COUNTY, FLORIDA.
A/K/A 560 YALE ROAD, VENICE, FL 34293
Any person claiming an interest in the surplus from the sale, if any, other than the property owner as of the date of the Lis Pendens, must file a claim within 60 days after the sale.
In accordance with the Americans With Disabilities Act, persons needing a reasonable accommodation to participate in this proceeding should contact the Clerk of the Circuit Court no later than seven business days prior to the proceeding at the Sarasota County Courthouse. Telephone 941-861-7425 (Sarasota and Venice) or 1-800-955-8770 via Florida Relay Service.
ALBERTELLI LAW
Attorney for Plaintiff
P.O. Box 23028
Tampa, FL 33623
(813) 221-4743
(813) 221-9171 facsimile
eService:
servealaw@albertellilaw.com
CH - 09-26164
October 5, 12, 2012 12-3758S

SECOND INSERTION

NOTICE OF RESCHEDULED SALE
IN THE CIRCUIT COURT OF THE
TWELFTH JUDICIAL CIRCUIT
IN AND FOR SARASOTA COUNTY,
FLORIDA
CIVIL ACTION
CASE NO.: 2009 CA 011338 NC
DIVISION: A
WACHOVIA MORTGAGE, FSB
A/K/A WORLD SAVINGS BANK,
FSB,
Plaintiff, vs.
RUSLAN PONOMARENKO, et al,
Defendants.
NOTICE IS HEREBY GIVEN Pursuant to an Order Rescheduling Foreclosure Sale dated September 24, 2012, and entered in Case No. 2009 CA 011338 NC of the Circuit Court of the Twelfth Judicial Circuit in and for Sarasota County, Florida in which Wachovia Mortgage, FSB a/k/a World Savings Bank, FSB, is the Plaintiff and Ruslan Ponomarenko, Sviatlana Dunchyk, are defendants, I will sell to the highest and best bidder for cash in/on the Internet: www.sarasota.realforeclose.com , Sarasota County, Florida at 9:00am on the 24th day of October, 2012, the following described property as set forth in said Final Judgment of Foreclosure:
LOT 5, BLOCK 575, 18TH ADDITION TO PORT CHARLOTTE SUBDIVISION, ACCORDING TO THE PLAT THEREOF, AS RECORDED IN PLAT BOOK 14, AT PAGE(S) 6, 6A THROUGH 6V, INCLUSIVE, OF THE PUBLIC RECORDS OF SARASOTA COUNTY, FLORIDA.
A/K/A : 2590 DE GARMO STREET, NORTH PORT, FL 34286
Any person claiming an interest in the surplus from the sale, if any, other than the property owner as of the date of the Lis Pendens, must file a claim within 60 days after the sale.
In accordance with the Americans With Disabilities Act, persons needing a reasonable accommodation to participate in this proceeding should contact the Clerk of the Circuit Court no later than seven business days prior to the proceeding at the Sarasota County Courthouse. Telephone 941-861-7425 (Sarasota and Venice) or 1-800-955-8770 via Florida Relay Service.
ALBERTELLI LAW
Attorney for Plaintiff
P.O. Box 23028
Tampa, FL 33623
(813) 221-4743
(813) 221-9171 facsimile
eService:
servealaw@albertellilaw.com
09-20503
October 5, 12, 2012 12-3760S

SECOND INSERTION

NOTICE OF RESCHEDULED
FORECLOSURE SALE
IN THE CIRCUIT COURT OF THE
TWELFTH JUDICIAL CIRCUIT, IN
AND FOR SARASOTA COUNTY,
FLORIDA
CIVIL ACTION
CASE NO.: 2008 CA 000208 SC
DIVISION: C
U.S. BANK NATIONAL
ASSOCIATION, TRUSTEE FOR
JP MORGAN ACQUISITION
TRUST-2006 ACC,
Plaintiff, vs.
DAVID CULVER, et al,
Defendant(s).
NOTICE IS HEREBY GIVEN pursuant to an Order Rescheduling Foreclosure Sale dated September 24, 2012 and entered in Case No. 2008 CA 000208 SC of the Circuit Court of the TWELFTH Judicial Circuit in and for SARASOTA County, Florida wherein U.S. BANK NATIONAL ASSOCIATION, TRUSTEE FOR JP MORGAN ACQUISITION TRUST-2006 ACC, is the Plaintiff and DAVID CULVER; DONNA CULVER; ANNE CLAIBORNE CHIPLEY; are the Defendants. The Clerk will sell to the highest and best bidder for cash at WWW.SARASOTA.REALFORECLOSE.COM at 9:00AM, on 10/29/2012, the following described property as set forth in said Final Judgment:
LOT 19, BLOCK B, GROVE PARK, ACCORDING TO THE PLAT THEREOF RECORDED IN PLAT BOOK 1, PAGE 109, OF THE PUBLIC RECORDS OF SARASOTA COUNTY, FLORIDA.
A/K/A 4084 GROVELAND AVENUE, SARASOTA, FL 34231
Any person claiming an interest in the surplus from the sale, if any, other than the property owner as of the date of the Lis Pendens must file a claim within sixty (60) days after the sale.
In accordance with the Americans With Disabilities Act, persons needing a reasonable accommodation to participate in this proceeding should contact the Clerk of the Circuit Court no later than seven business days prior to the proceeding at the Sarasota County Courthouse. Telephone 941-861-7425 (Sarasota and Venice) or 1-800-955-8770 via Florida Relay Service.
By: Ashleigh L. Price
Florida Bar No. 51416
RONALD R WOLFE &
ASSOCIATES, P.L.
P.O. Box 25018
Tampa, Florida 33622-5018
(813) 251-4766
F07067946
October 5, 12, 2012 12-3792S

SECOND INSERTION

NOTICE OF FORECLOSURE SALE
IN THE CIRCUIT COURT OF THE
TWELFTH JUDICIAL CIRCUIT
IN AND FOR SARASOTA COUNTY,
FLORIDA
GENERAL JURISDICTION
DIVISION
CASE NO.: 2010 CA 012886 NC
CitiMortgage, Inc.
Plaintiff, vs.
Christopher R. Koloski a/k/a Chris
R. Koloski,
Defendants.
NOTICE IS HEREBY GIVEN pursuant to a Summary Final Judgment of Foreclosure dated August 21, 2012, entered in Case No. 2010 CA 012886 NC of the Circuit Court of the TWELFTH Judicial Circuit, in and for Sarasota County, Florida, wherein CitiMortgage, Inc. is the Plaintiff and Christopher R. Koloski a/k/a Chris R. Koloski; Clare L. Koloski; Tarmac America, LLC.; Pine Ranch Owners Association, Inc. are the Defendants, that the clerk of courts will sell to the highest and best bidder for cash by electronic sale at www.sarasota.realforeclose.com, beginning at 9:00 AM on the 19 day of November, 2012, the following described property as set forth in said Final Judgment, to wit:
LOT 5, PINE RANCH SUBDIVISION, ACCORDING TO THE PLAT THEREOF AS RECORDED IN PLAT BOOK 23, PAGE 46 AND 46 A/B, PUBLIC RECORDS OF SARASOTA COUNTY, FLORIDA.
ANY PERSON CLAIMING AN INTEREST IN THE SURPLUS FROM THE SALE, IF ANY, OTHER THAN THE PROPERTY OWNER AS OF THE DATE OF THE LIS PENDENS, MUST FILE A CLAIM WITHIN 60 DAYS AFTER THE SALE.
In accordance with the Americans With Disabilities Act, persons needing a reasonable accommodation to participate in this proceeding should contact the Clerk of the Circuit Court no later than seven business days prior to the proceeding at the Sarasota County Courthouse. Telephone 941-861-7425 (Sarasota and Venice) or 1-800-955-8770 via Florida Relay Service.
Dated this 26th day of September, 2012.
By: Jessica Jo Fagen, Esq.
Florida Bar No. 50668
BROCK & SCOTT, PLLC
Attorney for Plaintiff
1501 N.W. 49th Street,
Suite 200
Pt. Lauderdale, FL 33309
Phone: (954) 618-6955, ext. 6105
Fax: (954) 618-6954
FLCourtDocs@brockandscott.com
11-F00766
October 5, 12, 2012 12-3763S

SECOND INSERTION

NOTICE OF FORECLOSURE SALE
IN THE CIRCUIT COURT OF THE
TWELFTH JUDICIAL CIRCUIT
IN AND FOR
SARASOTA COUNTY, FLORIDA
CASE NO.: 2012CA002890NC
FEDERAL NATIONAL
MORTGAGE ASSOCIATION,
Plaintiff, vs.
BRIAN J. WENTZ, TRACEY L.
WENTZ, WELLS FARGO BANK
NATIONAL ASSOCIATION
SUCCESSOR BY MERGER TO
WACHOVIA BANK NATIONAL
ASSOCIATION UNKNOWN
TENANT(S) IN POSSESSION #1
and #2, and ALL OTHER
UNKNOWN PARTIES, et al.,
Defendant(s).
NOTICE IS HEREBY GIVEN pursuant to a Final Summary Judgment of Foreclosure dated September 10, 2012, entered in Civil Case No.: 2012CA002890NC of the Circuit Court of the Twelfth Judicial Circuit in and for Sarasota County, Florida, wherein FEDERAL NATIONAL MORTGAGE ASSOCIATION, Plaintiff, and BRIAN J. WENTZ, TRACEY L. WENTZ, WELLS FARGO BANK NATIONAL ASSOCIATION SUCCESSOR BY MERGER TO WACHOVIA BANK NATIONAL ASSOCIATION, are Defendants.
KAREN E. RUSHING, the Clerk of the Circuit Court, will sell to the highest bidder for cash, www.sarasota.realforeclose.com, at 09:00 AM, on the 18th day of October, 2012, the following described real property as set forth in said Final Summary Judgment, to

SECOND INSERTION

wit:
LOTS 9 AND 10, BLOCK 222, 8TH ADDITION TO PORT CHARLOTTE SUBDIVISION, ACCORDING TO THE PLAT THEREOF, AS RECORDED IN PLAT BOOK 12, PAGE 20, OF THE PUBLIC RECORDS OF SARASOTA COUNTY, FLORIDA.
If you are a person claiming a right to funds remaining after the sale, you must file a claim with the clerk no later than 60 days after the sale. If you fail to file a claim you will not be entitled to any remaining funds. After 60 days, only the owner of record as of the date of the lis pendens may claim the surplus.
In accordance with the Americans With Disabilities Act, persons needing a reasonable accommodation to participate in this proceeding should contact the Clerk of the Circuit Court no later than seven business days prior to the proceeding at the Sarasota County Courthouse. Telephone 941-861-7425 (Sarasota and Venice) or 1-800-955-8770 via Florida Relay Service.
Dated: September 27, 2011
By: Brian Rosaler, Esq.
Attorney for Plaintiff:
Brian L. Rosaler, Esq.
POPKIN & ROSALER, P.A.
1701 West Hillsboro Boulevard
Suite 400
Deerfield Beach, FL 33442
Telephone: (954) 360-9030
Facsimile: (954) 420-5187
11-26922
October 5, 12, 2012 12-3777S

THIRD INSERTION

NOTICE OF SUSPENSION
TO: Anthony C. Spikes
Case No: 201103203

A Notice of Suspension to suspend your license and eligibility for licensure has been filed against you. You have the right to request a hearing pursuant to Sections 120.569 and 120.57, Florida Statutes, by mailing a request for same to the Florida Department of Agriculture and Consumer Services, Division of Licensing, Post Office Box 3168, Tallahassee, Florida 32315-3168. If a request for hearing is not received by 21 days from the date of the last publication, the right to hearing in this matter will be waived and the Department will dispose of this cause in accordance with law.
Sept. 28; Oct. 5, 12, 19, 2012 12-3700S

SAVE TIME
Fax your Legal Notice
Sarasota / Manatee Counties 941.954.8530
Hillsborough County 813.221.9403
Pinellas County 727.447.3944
Lee County 239.936.1001
Collier County 239.263.0112
Wednesday Noon
Deadline
Friday Publication
SAVE TIME
GULF COAST
Business Review
www.review.net

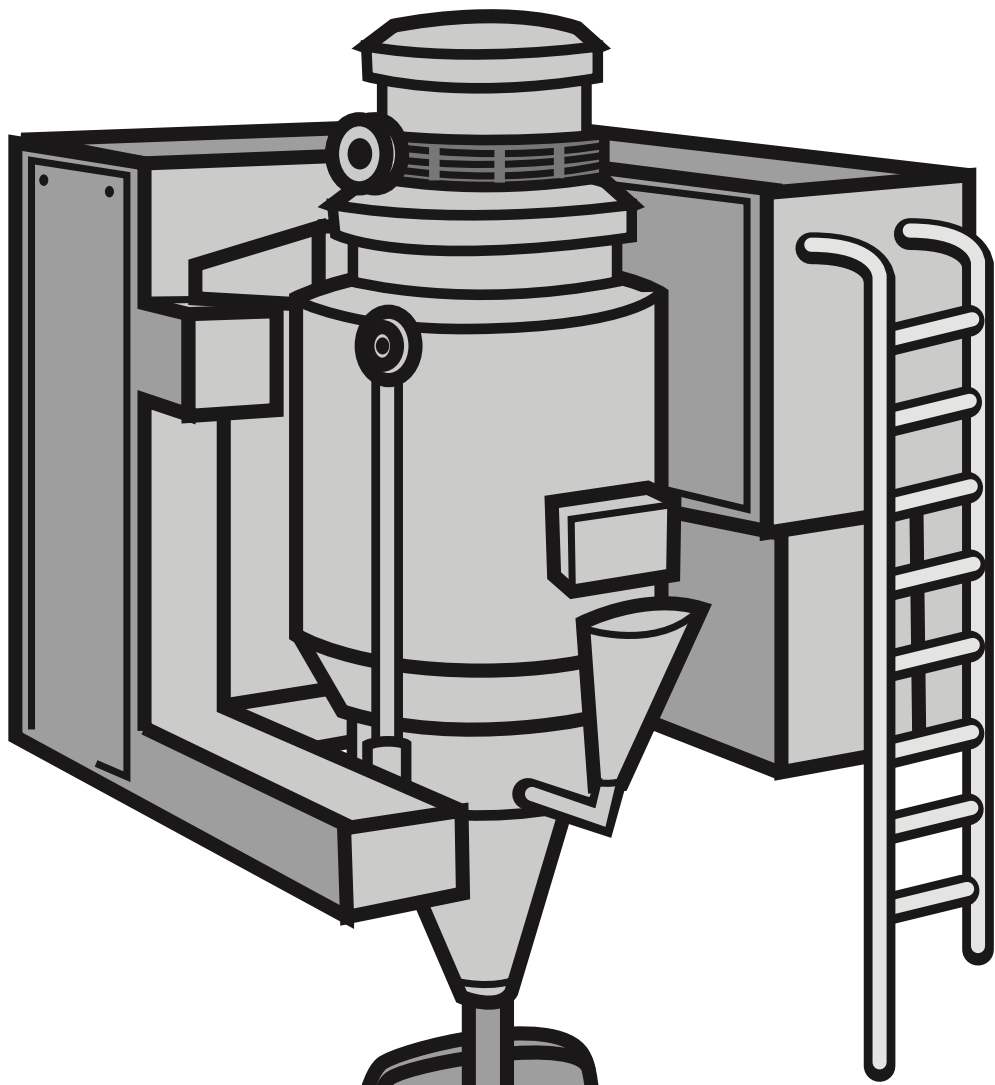

A special printing of
a classic story illustrating
the importance of
protecting capitalism.

TOM SMITH AND HIS INCREDIBLE BREAD MACHINE

By R.W. Grant

Illustrations by Austin McKinley

This is the legend of a man whose name
Was a household word: a man whose fame
Burst on the world like an atom bomb.
Smith was his last name; first name: Tom.

The argument goes on today.
"He was a villain," some will say.
"No! A hero!" others declare.
Or was he both? Well, I despair;
The fight will last 'til kingdom come;
Was Smith a hero? Or was Smith a bum?
So, listen to the story and it's up to you
To decide for yourself as to which is true!

Now, Smith, an inventor, had specialized
In toys. So people were surprised
When they found that he instead
Of making toys, was baking bread!
The news was flashed by CBS
Of his incredible success.
Then NBC jumped in in force,
Followed by the Times, of course.
The reason for their rapt attention,
The nature of his new invention,
The way to make bread he'd conceived
Cost less than people could believe!
And not just make it! This device
Could in addition wrap and slice!
The price per loaf, one loaf or many:
The miniscule sum of under one penny!

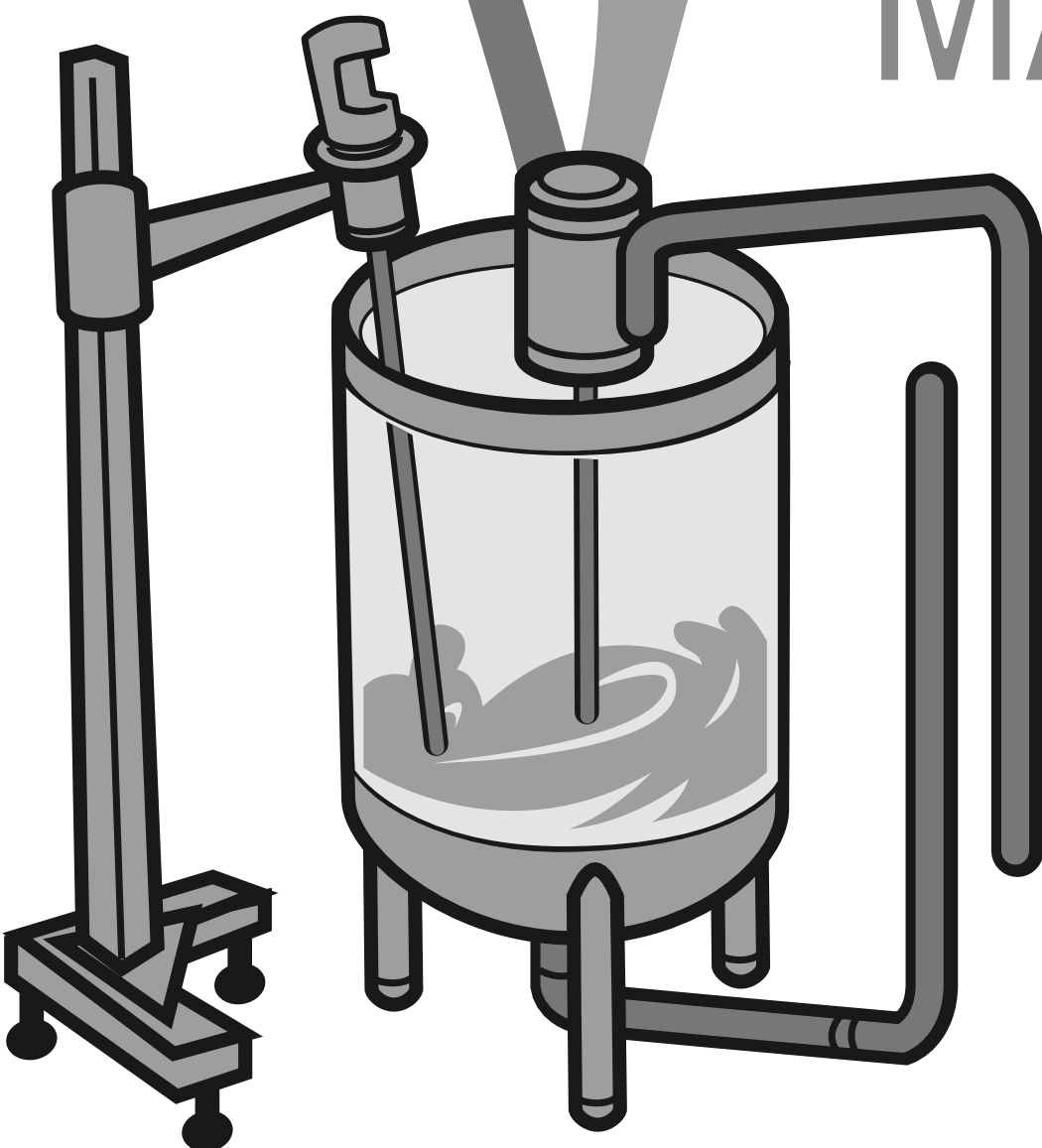

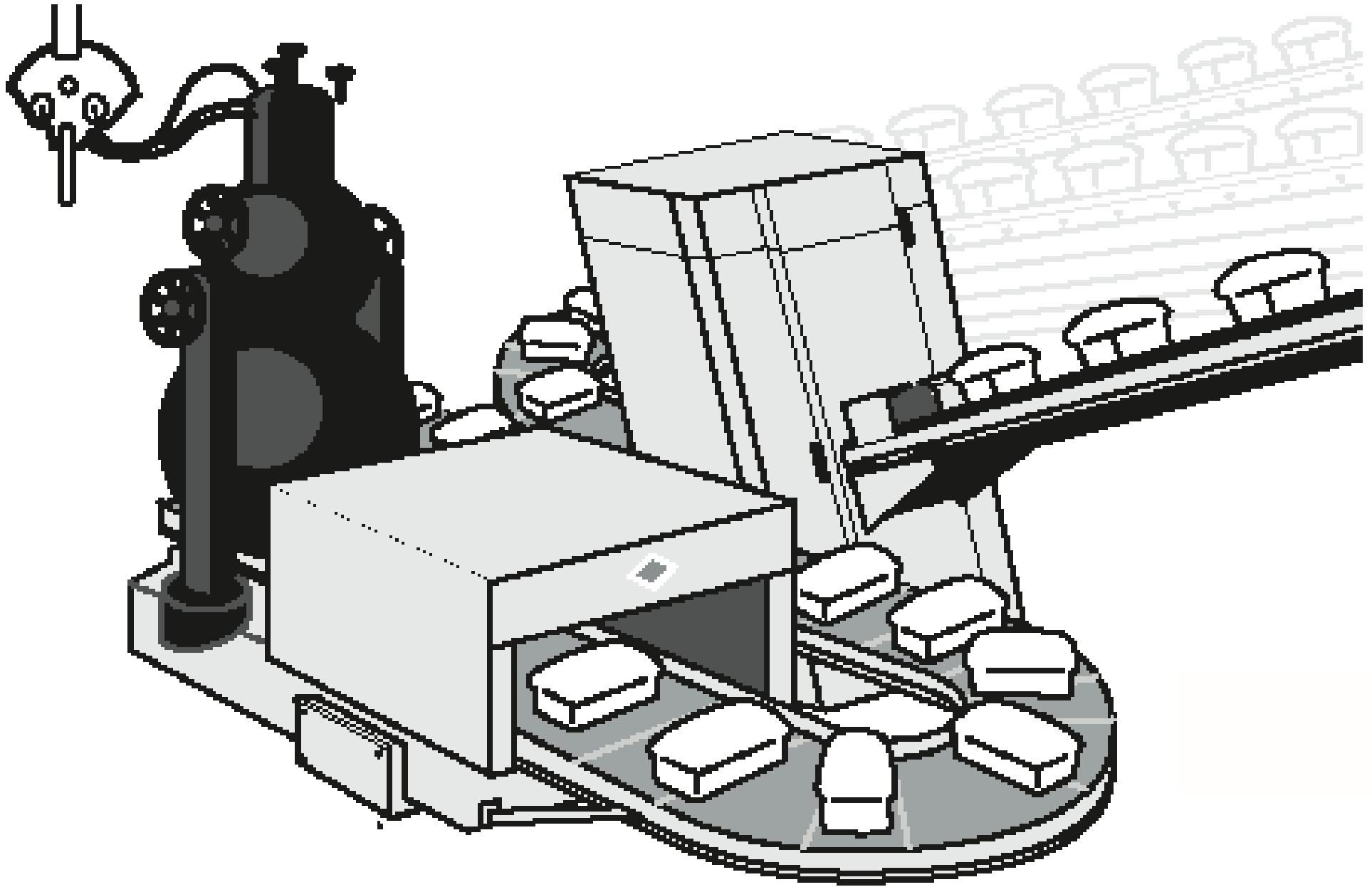

This is the legend of a man whose name
Was a household word: a man whose
fame

Burst on the world like an atom bomb.
Smith was his last name; first name: Tom.

The argument goes on today.
"He was a villain," some will say.
"No! A hero!" others declare.
Or was he both? Well, I despair;
The fight will last 'til kingdom come;
Was Smith a hero? Or was Smith a bum?
So, listen to the story and it's up to you
To decide for yourself as to which is true!

Now, Smith, an inventor, had specialized
In toys. So people were surprised
When they found that he instead
Of making toys, was baking bread!
The news was flashed by CBS
Of his incredible success.
Then NBC jumped in in force,
Followed by the Times, of course.
The reason for their rapt attention,
The nature of his new invention,
The way to make bread he'd conceived
Cost less than people could believe!
And not just make it! This device
Could in addition wrap and slice!
The price per loaf, one loaf or many:
The miniscule sum of under one penny!

Can you imagine what this meant?
Can you comprehend the consequent?
The first time yet the world well fed!
And all because of Tom Smith's bread!

Not the last to see the repercussions

Were the Red Chinese, and, of course, the
Russians,
For Capitalist bread in such array

Threw the whole red block into black dis-
may!
Nonetheless, the world soon found
That bread was plentiful the world
around.
Thanks to Smith and all that bread,
A grateful world was at last well fed!

But isn't it a wondrous thing
How quickly fame is flown?
Smith, the hero of today
Tomorrow, scarcely known!
Yes, the fickle years passed by.
Smith was a billionaire.

But Smith himself was now forgot,
Though bread was everywhere.
People, asked from where it came,
Would very seldom know.

They would simply eat and ask,
'Was not it always so?'

However, Smith cared not a bit,
For millions ate his bread,
And "Everything is fine," thought he.
"I'm rich and they are fed!"

Everything was fine, he thought?
He reckoned not with fate.
Note the sequence of events
Starting on the date
On which inflation took its toll,
And to a slight extent,

The price on every loaf increased:
It went to one full cent!

A sharp reaction quickly came.
People were concerned.
White House aide expressed dismay.
Then the nation learned
That Russia lodged a sharp protest.
India did the same.
"Exploitation of the Poor!"
Yet, who was there to blame?

And though the clamor ebbed and flowed,
All that Tom would say
Was that it was but foolish talk.
Which soon would die away.
And it appeared that he was right.
Though on and on it ran,
The argument went 'round and 'round
But stopped where it began.

There it stopped, and people cried,
"For heaven's sake, we can't decide!
It's relative! Beyond dispute,
There's no such thing as 'absolute'!
And though we try with all our might,
Since nothing's ever black or white,
All that we can finally say is
'Everything one shade of grey is!'
So people cried out, "Give us light!
We can't tell what's wrong from right!"



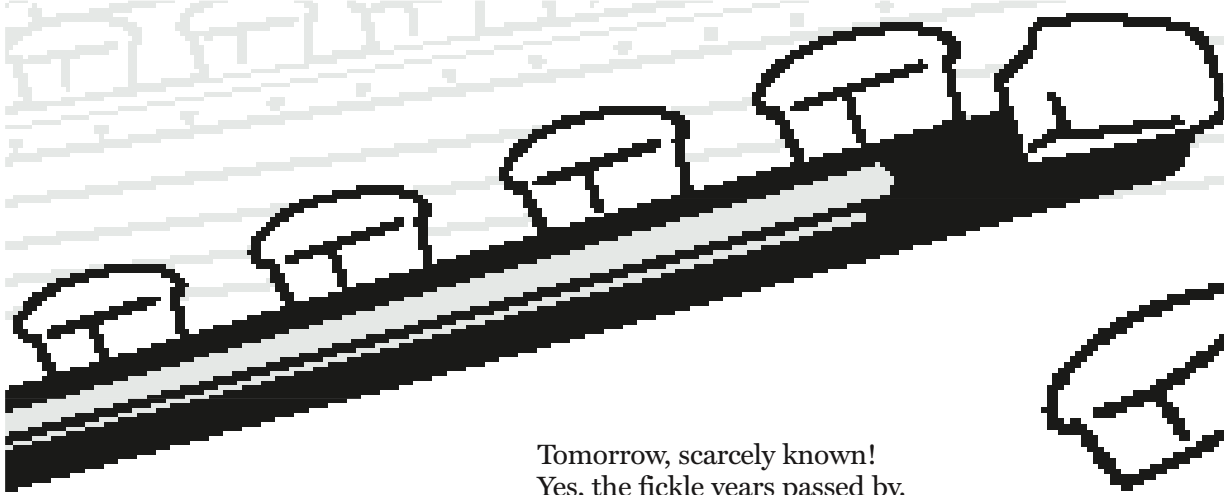

This is the legend of a man whose name
Was a household word: a man whose fame
Burst on the world like an atom bomb.
Smith was his last name; first name:
Tom.

The argument goes on today.
"He was a villain," some will say.
"No! A hero!" others declare.
Or was he both? Well, I despair;
The fight will last 'til kingdom come;
Was Smith a hero? Or was Smith a bum?
So, listen to the story and it's up to you
To decide for yourself as to which is true!

Now, Smith, an inventor, had specialized
In toys. So people were surprised
When they found that he instead
Of making toys, was baking bread!
The news was flashed by CBS
Of his incredible success.
Then NBC jumped in in force,
Followed by the Times, of course.
The reason for their rapt attention,
The nature of his new invention,
The way to make bread he'd conceived
Cost less than people could believe!
And not just make it! This device
Could in addition wrap and slice!
The price per loaf, one loaf or many:
The miniscule sum of under one penny!

Can you imagine what this meant?
Can you comprehend the consequent?
The first time yet the world well fed!
And all because of Tom Smith's bread!

Not the last to see the repercussions
Were the Red Chinese, and, of course,
the Russians,
For Capitalist bread in such array

Threw the whole red block into black dismay!
Nonetheless, the world soon found
That bread was plentiful the world around.
Thanks to Smith and all that bread,
A grateful world was at last well fed!

But isn't it a wondrous thing
How quickly fame is flown?
Smith, the hero of today

Tomorrow, scarcely known!
Yes, the fickle years passed by.
Smith was a billionaire.

But Smith himself was now forgot,
Though bread was everywhere.
People, asked from where it came,
Would very seldom know.

They would simply eat and ask,
"Was not it always so?"

However, Smith cared not a bit,
For millions ate his bread,
And "Everything is fine," thought he.
"I'm rich and they are fed!"

Everything was fine, he thought?
He reckoned not with fate.
Note the sequence of events
Starting on the date
On which inflation took its toll,
And to a slight extent,
The price on every loaf increased:
It went to one full cent!

A sharp reaction quickly came.
People were concerned.

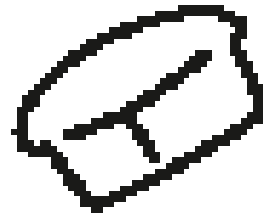
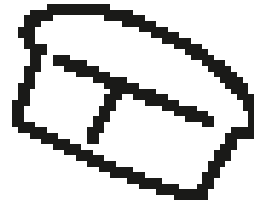
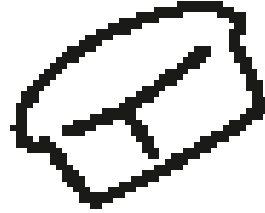

White House aide expressed dismay.
Then the nation learned
That Russia lodged a sharp protest.
India did the same.
"Exploitation of the Poor!"
Yet, who was there to blame?

And though the clamor ebbed and flowed,
All that Tom would say
Was that it was but foolish talk.
Which soon would die away.
And it appeared that he was right.
Though on and on it ran,
The argument went 'round and 'round
But stopped where it began.

There it stopped, and people cried,
"For heaven's sake, we can't decide!
It's relative! Beyond dispute,
There's no such thing as 'absolute'!
And though we try with all our might,
Since nothing's ever black or white,
All that we can finally say is
'Everything one shade of grey is!'
So people cried out, "Give us light!
We can't tell what's wrong from right!"

To comprehend confusion,
We seek wisdom at its source.
To whom, then did the people turn?
The Intellectuals, of course!

And what could be a better time
For them to take the lead,
Than at their International Conference
On Inhumanity and Greed.
For at this weighty conference,
Once each year we face

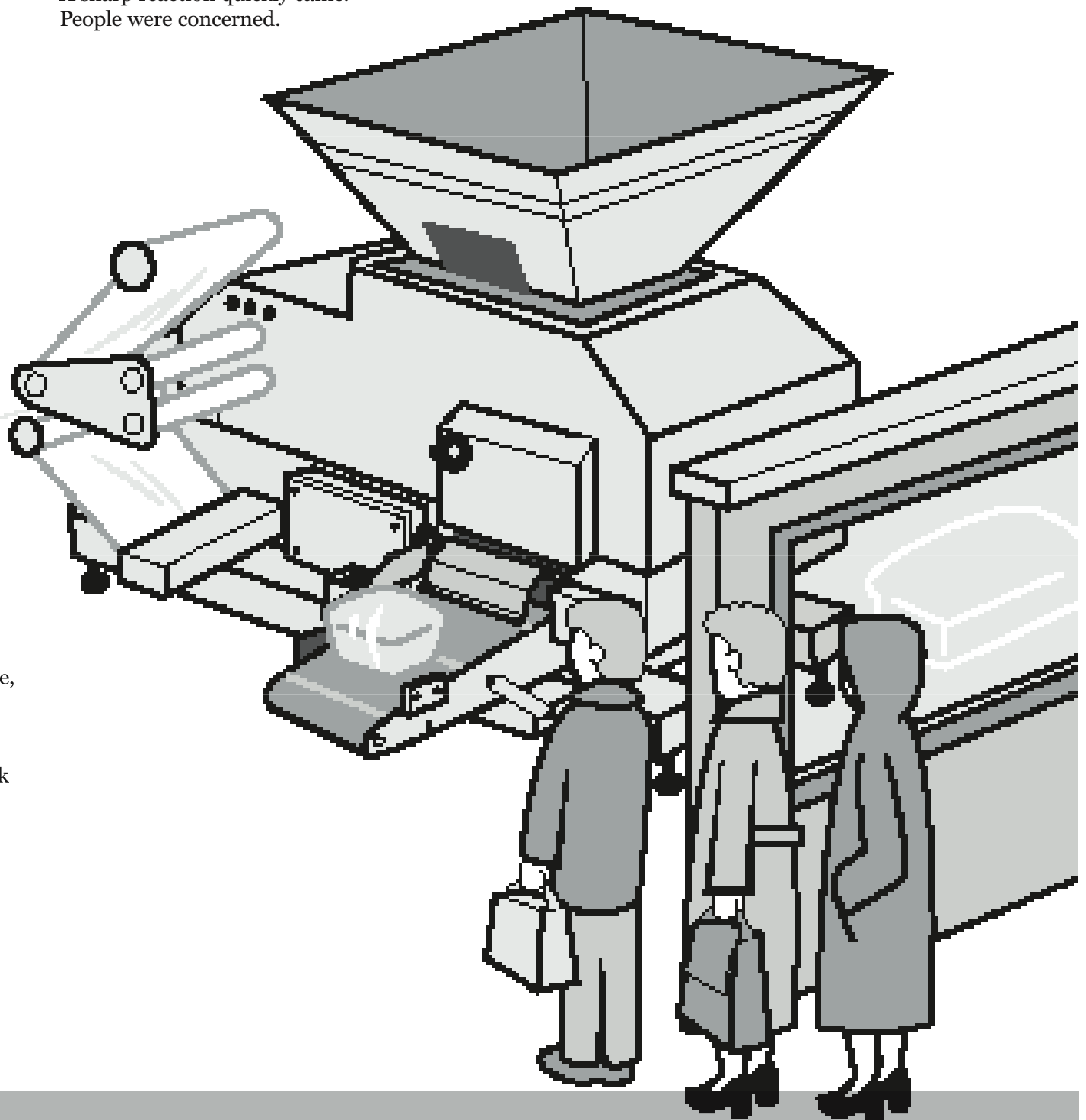

This is the legend of a man whose name
Was a household word: a man whose
fame
Burst on the world like an atom bomb.
Smith was his last name; first name: Tom.

The argument goes on today.
“He was a villain,” some will say.
“No! A hero!” others declare.
Or was he both? Well, I despair;
The fight will last ‘til kingdom come;
Was Smith a hero? Or was Smith a bum?
So, listen to the story and it’s up to you
To decide for yourself as to which is true!

Now, Smith, an inventor, had specialized
In toys. So people were surprised
When they found that he instead
Of making toys, was baking bread!
The news was flashed by CBS
Of his incredible success.
Then NBC jumped in in force,
Followed by the Times, of course.
The reason for their rapt attention,
The nature of his new invention,
The way to make bread he’d conceived
Cost less than people could believe!
And not just make it! This device
Could in addition wrap and slice!
The price per loaf, one loaf or many:
The miniscule sum of under one penny!

Can you imagine what this meant?
Can you comprehend the consequent?
The first time yet the world well fed!
And all because of Tom Smith’s bread!

Not the last to see the repercussions
Were the Red Chinese, and, of course, the
Russians,
For Capitalist bread in such array

Threw the whole red block into black
dismay!
Nonetheless, the world soon found
That bread was plentiful the world
around.
Thanks to Smith and all that bread,
A grateful world was at last well fed!

But isn’t it a wondrous thing
How quickly fame is flown?
Smith, the hero of today
Tomorrow, scarcely known!
Yes, the fickle years passed by.
Smith was a billionaire.

But Smith himself was now forgot,
Though bread was everywhere.
People, asked from where it came,
Would very seldom know.

They would simply eat and ask,
“Was not it always so?”

However, Smith cared not a bit,
For millions ate his bread,
And “Everything is fine,” thought he.
“I’m rich and they are fed!”

Everything was fine, he thought?
He reckoned not with fate.
Note the sequence of events
Starting on the date
On which inflation took its toll,
And to a slight extent,
The price on every loaf increased:
It went to one full cent!

A sharp reaction quickly came.
People were concerned.
White House aide expressed dismay.
Then the nation learned
That Russia lodged a sharp protest.
India did the same.
“Exploitation of the Poor!”
Yet, who was there to blame?

And though the clamor ebbed and flowed,
All that Tom would say
Was that it was but foolish talk.
Which soon would die away.
And it appeared that he was right.
Though on and on it ran,
The argument went ‘round and ‘round
But stopped where it began.

There it stopped, and people cried,
“For heaven’s sake, we can’t decide!
It’s relative! Beyond dispute,
There’s no such thing as ‘absolute’!
And though we try with all our might,
Since nothing’s ever black or white,
All that we can finally say is
‘Everything one shade of grey is!’”
So people cried out, “Give us light!
We can’t tell what’s wrong from right!”

To comprehend confusion,
We seek wisdom at its source.
To whom, then did the people turn?
The Intellectuals, of course!

And what could be a better time
For them to take the lead,
Than at their International Conference
On Inhumanity and Greed.
For at this weighty conference,
Once each year we face
The moral conscience of the world—
Concentrated in one place.

At that mighty conference were
A thousand, more or less,
Of intellectuals and bureaucrats,
And those who write the press.
And from Yale and Harvard
The professors; all aware
The fate of Smith would now be known.
Excitement filled the air!

“The time has come,” the chairman said
“To speak of many things:
Of duty, bread and selfishness,
And the evil that it brings.
For, speaking thus we can amend
That irony of fate
That gives to unenlightened minds
The power to create.

“Since reason tells us that it can’t,
Therefore let us start
Not by thinking with the mind,
But only with the heart!
Since we believe in people, then,”
At last the chairman said,
“We must meet our obligation
To see that they are fed!”

And so it went, one by one,
Denouncing private greed;
Denouncing those who’d profit thus
From other people’s need!

Then, suddenly each breath was held,
For there was none more wise
Than the nation’s foremost Pundit
Who now rose to summarize:

“My friends,” he said, (they all exhaled)
“We see in these events
The flouting of the Higher Law—
And its consequence.
We must again remind ourselves
Just why mankind is cursed:
Because we fail to realize
Society comes first!

“Smith placed himself above the group
To profit from his brothers.
He failed to see the Greater Good,
Is Service, friends, to Others!”

With boldness and with vision, then,
They ratified the motion
To dedicate to all mankind
Smith’s bread-and their devotion!

The conference finally ended.
It had been a huge success.
The intellectuals had spoken.
Now others did the rest.

The professors joined in all the fuss,
And one was heard to lecture thus:
(For clarity, he spoke in terms
Of Mother Nature, birds and worms):

“That early birds should get the worm
Is clearly quite unfair.
Wouldn’t it much nicer be
If all of them would share?
But selfishness and private greed

Seem part of nature’s plan,
Which Mother Nature has decreed
For bird. But also Man?
The system which I question now,
As you are well aware,
(I’m sure you’ve heard the term before
Is Business, Laissez-Faire!

“So students, let me finally say
That we must find a nobler way.
So, let us fix the race that all
May finish side-by-side;
The playing field forever flat,
The score forever tied.
To achieve this end, of course,
We turn to government-and force.
So, if we have to bring Smith do
As indeed we should,
I’m sure you will agree with me,
It’s for the Greater Good!”

Comments in the nation’s press
Now scorned Smith and his plunder:
“What right had he to get so rich
On other people’s hunger?”
A prize cartoon depicted Smith
With fat and drooping jowls
Snatching bread from hungry babes,
Indifferent to their howls.

One night, a TV star cried out,
“Forgive me if I stumble,
But I don’t think, I kid you not,
That Smith is very humble!”
Growing bolder, he leaped up,
(Silencing the cheers)
“Humility!” he cried to all—
And then collapsed in tears!

The clamor rises all about;
Now hear the politician shout:
“What’s Smith done, so rich to
be?

