

PUBLIC NOTICES

An American Tradition

Public notice is an important tool in assuring an informed citizenry. Notices are mandated by legislatures to make sure there is a public window into the activities of governments, officers of the court and others holding a public trust. There are four key elements to a valid public notice. It should be executed by an entity outside the one mandated to provide notice, so proper checks and balances are in place.

A public notice informs citizens of government or government-related activities that affect citizens' everyday lives. A public notice typically has four elements:

- **Independent:** A public notice is published in a forum independent of the government, typically in a local newspaper.
- **Archivable:** A public notice is archived in a secure and publicly available format.
- **Accessible:** A public notice is capable of being accessed by all segments of society.
- **Verifiable:** The public and the source of the notice are able to verify that the notice was published, usually by an affidavit provided by the publisher.

(Adapted from the Public Resource Notice Center)

Types of Public Notices

There are three standard types:

- **Citizen participation notices** inform the public about proposed government action and allow the public time to react to such proposals.

One such example is a public hearing notice.

- **Business and commerce notices**

relate to government contracts and purchases. Notices of contract bids allow citizens to ensure that the government is operating in accordance with principles of equal opportunity and is acting responsibly in spending taxpayer money.

- **Court notices** are required of many non-governmental entities that

use public powers or institutions in some way. Examples include notices of home mortgage foreclosures, which can provide a public alert of widespread credit problems, fraud in underwriting and a basis for analyses of housing trends.

This notice allows the public to object to an appointment based on any conflict of interest.

The history of public notices

Public notices existed long before the emergence of newspapers. The concept itself began when early civilizations posted notices in public squares. This crude method was eventually refined with the publication of the first English language newspaper in 1665 — a court newspaper called the Oxford Gazette. After being renamed The London Gazette, this official newspaper carried notices from the King's Court, London

officials and outlying regions.

The American system is modeled after the British system. State governments published public notices before America's founding, and the newly-created federal government followed suit. In 1789, the Acts of the First Congress required the Secretary of State to publish all bills, orders, resolutions and congressional votes in at least three publicly available newspapers.

An important premise both in federal

and local governments of the United States, as well as in many republics around the world, is that information about government activities must be accessible for the electorate to make well-informed decisions.

Public notices in newspapers still provide this accessibility to citizens who want to know more about government activities. Public notice laws serve to outline the most effective method of reaching the public.

Public notice supports due process

Public notices are integral to democratic governance and stem from the right to "due process of law" guaranteed by the federal and state constitutions. Due process of law protects Americans' rights from arbitrary or wrongful violations. This concept has two parts: substantive due process and procedural due process.

Substantive due process refers to the

types of rights that are protected. Procedural due process refers to the means of protecting those rights.

Substantive due process ensures that certain basic rights are not violated, while procedural due process may require suitable notice and a hearing before a government or court-appointed body can act in a way that may affect those basic rights.

Public notices play a vital role in

substantive and procedural due process because they provide a window into government actions and also afford notice to citizens of actions about to take place so they may exercise their constitutional right to be heard. Notification not only informs the individual or entity most directly affected, but it also informs the public, which has an interest in knowing how public powers are being used.

WHY NEWSPAPERS?

Newspapers are the primary source

Newspapers, founded on the constitutional right of free press, have been serving the public's right to know in America since pre-colonial times and on the European continent since the 17th century. Because of their traditional information role in society and their long-established independence, newspapers remain the primary source for publishing public notices.

Upholding the public's right to know is essential to our country's way of life. Our government governs with the consent of the people, and this consent must be informed. Local newspapers keep the public informed about the inner workings of their respective state and local governments, thereby allowing citizens to participate more fully in the democratic process. Without this participation, the potential for misguided policies increases.

Newspaper tradition

Newspapers allow the government to notify the public of government actions. The government has a fundamental responsibility to ensure adequate notification to the public of its actions. Therefore, the government has a duty to make sure the methods used in satisfying this responsibility are the most effective.

Newspapers provide neutrality from government and credible distance from political pressures or partisan disagreements. Local and community newspapers serve as third-party reporters to the public, publishing information that can be beneficial or sometimes detrimental to the government's public image. They provide an environment for notices that the

public traditionally has regarded as neutral. Public notices in this print environment gain credibility because of the long history of trust in the local newspaper.

Placing notices on government Web sites undermines this neutral interest and removes a critical check and balance. While it may seem appealing on the surface in an age of ever-more sophisticated government Web sites, the potential for mishandling is great.

On the other hand, public notices in independent newspapers increase government transparency by opening up the decision-making process to the public's eyes. Without this oversight, local governments could enact controversial policies without input from the public.

Newspapers serve as effective monitors of governments and ensure that they publish information as required by law. Public notices are typically required by a statute or a regulation. The independent press can provide a valuable civic role by helping to monitor that the notices were published when required. If governments were responsible for publishing their own notices, no neutral and independent entity would have the incentive and the means to track public-notice publication.

Newspapers: The best medium for public notices

Newspapers, for the most of the republic's history, have been the accepted medium for public notices. This is exactly where the public, even infrequent readers, expects to find them. In addition, specialized publications, such as legal newspapers, are well known for

providing public notices to the population through legal communities. Other general interest newspapers, such as county seat weeklies, are the forum where county citizens expect to locate notices of important public business. Furthermore, the vast majority of these notices arrive at citizens' homes in a context that compels readership (amid local news, sports features and other content).

Another reason for the effectiveness of newspapers is that newspapers provide valid evidence of readership.

Legislatures are rightly concerned about web-only notices, given the digital divide between rich and poor, rural and urban residents. The Internet is either too costly or simply geographically unavailable to large segments of society.

Notices become historical records

The newspaper as paper of record is an important factor in the public policy of notices. Government Web sites cannot provide a secure archival history the way newspapers can. Electronic records lack permanence and can easily be intentionally or accidentally erased. Even the Library of Congress has recognized this shortcoming and has embarked upon a major project to attempt to archive digital records that are in danger of being "forever lost" due to Internet impermanence.

Despite these problems, the federal courts unwisely approved a rule change to the Federal Rules of Civil Procedure recently that would

THE RISKS OF NOTICES ONLY ON THE INTERNET

Although it has been part of American society for a quarter-century as a network for scholars and government agencies, the Internet has been widely used by citizens for about 15 years.

Because of its structure with computer clients and servers, information packets and open-network codes, the Internet remains vulnerable and sometimes unstable. Power surges, corrupted software and downed servers can disrupt access. Government agencies cannot ensure that information located on a server is secure.

Even a highly technological site like that of the Pentagon's has been affected. In June 2007, the Pentagon was forced to take about 1,500 computers off-line because of a cyber-attack. Then-Defense Department Secretary Robert Gates stated that the Pentagon sees hundreds of attacks every day.

Public notices guard our constitutional right to due process of law by informing citizens of government action and providing proof of publication via notarized affidavits of publication. Unlike the time-tested and trusted local newspapers that citizens have come to rely on for public notices, the Internet is an unstable medium for information. While it is valuable tool in disseminating information, it has not yet reached a level of sophistication and technological stability that would justify its supplanting newspapers as the primary venue for public notices.

It is still uncertain how a "Net" affidavit could show proof of a public notice publication when constant technological change makes any attempt at archiving and accessing such a document online for any significant time dubious.

No less problematic for the Internet is its reach. Those who live in rural areas where broadband does not exist and others who simply cannot afford the Internet cannot access web public notices. In situations where foreclosures are on the rise due, in part, to predatory mortgage lending, more, not less, access to public notices is needed to better inform citizens about their rights and their choices.

It is difficult to justify, then, moving public notices from newspapers only to public-notice Web sites administered either by already over-burdened state governments or by third-party vendors who lack the experience and long-term viability newspapers have proven in publishing notices.

So far in the Internet age, newspapers remain the most trusted and primary method for providing citizens access to public notices.

move notices of federal asset forfeitures out of newspapers and onto a Web site administered by the Department of Justice. Yet, the courts have little research to show that the Justice Department's Web site will produce viable, accessible, archivable notices.

While Internet web pages pose serious archiving challenges, newspapers, on the other hand, become historical documents. They are oriented and published with a date on every page. They cannot be deceptively altered after printing as a web page could. Historians, judges, lawyers, genealogists and researchers, to name only a few, use newspapers and public notices in particular as sources for records.

Newspaper notices protect due process

Procedural due process, as granted by the U.S. Constitution and interpreted

by courts, generally requires an individual to receive notice and a hearing before he or she is deprived of certain rights or property. For example, before a person's home is sold by a county sheriff at a foreclosure sale, he or she must receive notice of the foreclosure sale and an opportunity to save the house from foreclosure. If the owner does not receive the notice, he may challenge the sale in court. The court may then void the sale or prevent the sale from happening to protect due process.

Newspapers are generally paid to run public notices, which recognizes that their publication creates a cost in paper, ink and delivery.



GULF COAST housing permits

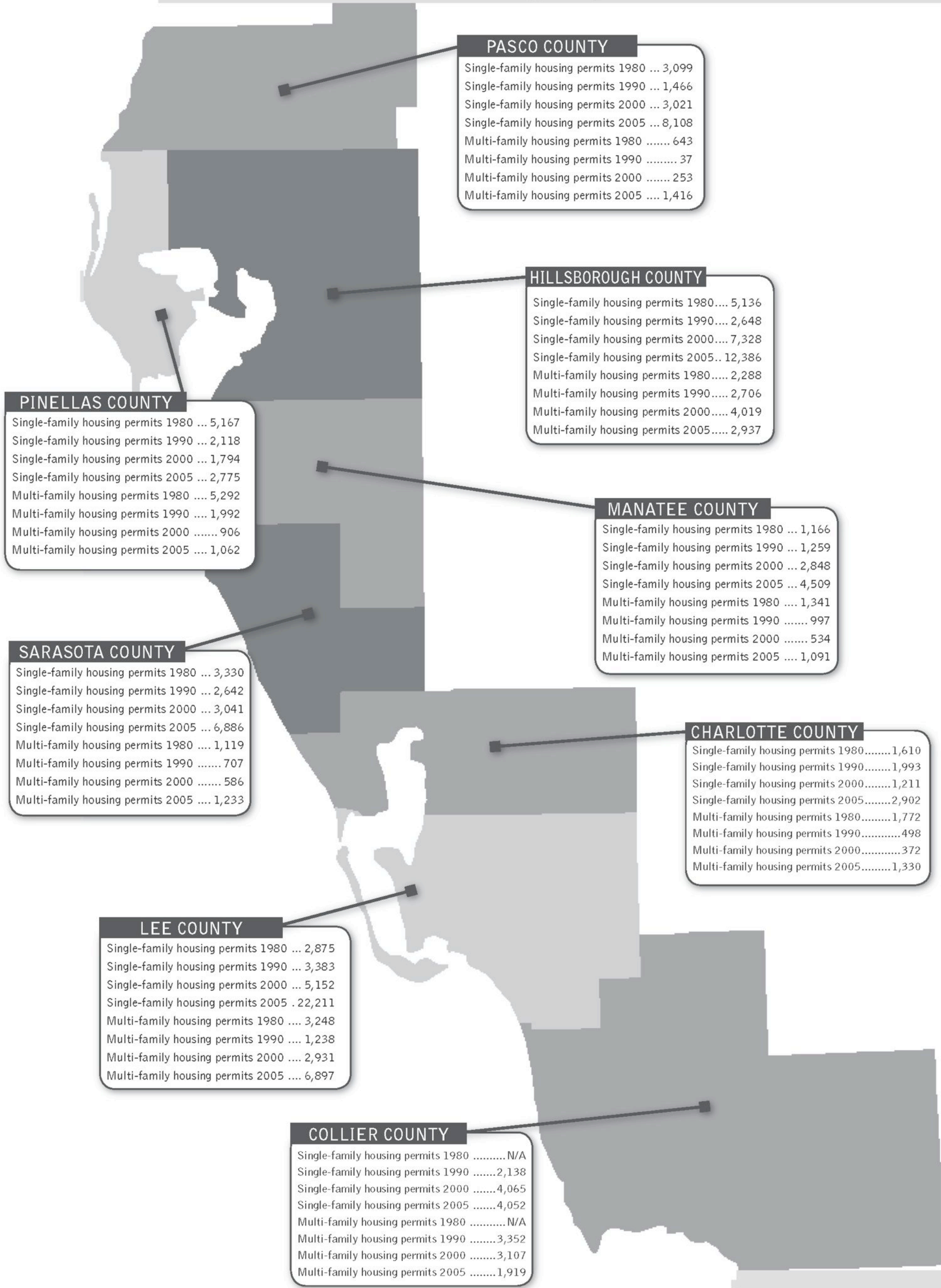

PASCO COUNTY

Single-family housing permits 1980 ... 3,099
 Single-family housing permits 1990 ... 1,466
 Single-family housing permits 2000 ... 3,021
 Single-family housing permits 2005 ... 8,108
 Multi-family housing permits 1980 643
 Multi-family housing permits 1990 37
 Multi-family housing permits 2000 253
 Multi-family housing permits 2005 1,416

HILLSBOROUGH COUNTY

Single-family housing permits 1980.... 5,136
 Single-family housing permits 1990.... 2,648
 Single-family housing permits 2000.... 7,328
 Single-family housing permits 2005.. 12,386
 Multi-family housing permits 1980..... 2,288
 Multi-family housing permits 1990..... 2,706
 Multi-family housing permits 2000..... 4,019
 Multi-family housing permits 2005..... 2,937

PINELLAS COUNTY

Single-family housing permits 1980 ... 5,167
 Single-family housing permits 1990 ... 2,118
 Single-family housing permits 2000 ... 1,794
 Single-family housing permits 2005 ... 2,775
 Multi-family housing permits 1980 5,292
 Multi-family housing permits 1990 1,992
 Multi-family housing permits 2000 906
 Multi-family housing permits 2005 1,062

MANATEE COUNTY

Single-family housing permits 1980 ... 1,166
 Single-family housing permits 1990 ... 1,259
 Single-family housing permits 2000 ... 2,848
 Single-family housing permits 2005 ... 4,509
 Multi-family housing permits 1980 1,341
 Multi-family housing permits 1990 997
 Multi-family housing permits 2000 534
 Multi-family housing permits 2005 1,091

SARASOTA COUNTY

Single-family housing permits 1980 ... 3,330
 Single-family housing permits 1990 ... 2,642
 Single-family housing permits 2000 ... 3,041
 Single-family housing permits 2005 ... 6,886
 Multi-family housing permits 1980 1,119
 Multi-family housing permits 1990 707
 Multi-family housing permits 2000 586
 Multi-family housing permits 2005 1,233

CHARLOTTE COUNTY

Single-family housing permits 1980.....1,610
 Single-family housing permits 1990.....1,993
 Single-family housing permits 2000.....1,211
 Single-family housing permits 2005.....2,902
 Multi-family housing permits 1980.....1,772
 Multi-family housing permits 1990.....498
 Multi-family housing permits 2000.....372
 Multi-family housing permits 2005.....1,330

LEE COUNTY

Single-family housing permits 1980 ... 2,875
 Single-family housing permits 1990 ... 3,383
 Single-family housing permits 2000 ... 5,152
 Single-family housing permits 2005 . 22,211
 Multi-family housing permits 1980 3,248
 Multi-family housing permits 1990 1,238
 Multi-family housing permits 2000 2,931
 Multi-family housing permits 2005 6,897

COLLIER COUNTY

Single-family housing permits 1980 N/A
 Single-family housing permits 1990 2,138
 Single-family housing permits 2000 4,065
 Single-family housing permits 2005 4,052
 Multi-family housing permits 1980 N/A
 Multi-family housing permits 1990 3,352
 Multi-family housing permits 2000 3,107
 Multi-family housing permits 2005 1,919

FIRST INSERTION

NOTICE TO CREDITORS
IN THE CIRCUIT COURT FOR
SARASOTA COUNTY, FLORIDA
PROBATE DIVISION
File No. 2013 CP004382NC
Division PROBATE
IN RE: ESTATE OF
CHRISTOPHER G. BERLINER
Deceased.

The administration of the estate of CHRISTOPHER G. BERLINER, deceased, whose date of death was October 26, 2013, is pending in the Circuit Court for SARASOTA County, Florida, Probate Division, the address of which is PO Box 3079, Sarasota, Florida 34236. The names and addresses of the personal representatives and the personal representatives' attorney are set forth below.

All creditors of the decedent and other persons having claims or demands against decedent's estate on whom a copy of this notice is required to be served must file their claims with this court WITHIN THE LATER OF 3 MONTHS AFTER THE TIME OF THE FIRST PUBLICATION OF THIS NOTICE OR 30 DAYS AFTER THE DATE OF SERVICE OF A COPY OF THIS NOTICE ON THEM.

All other creditors of the decedent and other persons having claims or demands against decedent's estate must file their claims with this court WITHIN 3 MONTHS AFTER THE DATE OF THE FIRST PUBLICATION OF THIS NOTICE.

ALL CLAIMS NOT FILED WITHIN THE TIME PERIODS SET FORTH IN SECTION 733.702 OF THE FLORIDA PROBATE CODE WILL BE FOREVER BARRED.

NOTWITHSTANDING THE TIME PERIODS SET FORTH ABOVE, ANY CLAIM FILED TWO (2) YEARS OR MORE AFTER THE DECEDENT'S DATE OF DEATH IS BARRED.

The date of first publication of this notice is December 20, 2013.

Co-Personal Representatives:

Frederick W. Berliner

546 Hall Hill Rd

Ancram, New York 12502

Benjamin C Berliner Jr

833 Tennessee Ln

Sarasota, Florida 34234

Attorney for Personal Representative:

DAVID W. PAYNE

Attorney for Co-Personal

Representatives

Florida Bar Number: 0958530

PAYNE LAW GROUP, P.A.

240 S Pineapple Ave, Suite 401

Sarasota, FL 34236

Telephone: (941) 487-2800

Fax: (941) 487-2801

E-Mail: dpayne@lawnav.com

Secondary E-Mail:

ppowers@lawnav.com

December 20, 27, 2013 13-05927S

FIRST INSERTION

NOTICE TO CREDITORS
IN THE CIRCUIT COURT FOR
SARASOTA COUNTY, FLORIDA
PROBATE DIVISION
File No. 2013 CP 4608 NC
IN RE: ESTATE OF:
FRANK A. SCHMIDT, JR.
Deceased.

The administration of the estate of Frank A. Schmidt, Jr., deceased, whose date of death was July 20, 2013, is pending in the Circuit Court for Sarasota County, Florida, Probate Division, the address of which is 2000 Main St, Sarasota, FL 34237. The names and addresses of the personal representative and the personal representative's attorney are set forth below.

All creditors of the decedent and other persons having claims or demands against decedent's estate, on whom a copy of this notice is required to be served must file their claims with this court WITHIN THE LATER OF 3 MONTHS AFTER THE TIME OF THE FIRST PUBLICATION OF THIS NOTICE OR 30 DAYS AFTER THE DATE OF SERVICE OF A COPY OF THIS NOTICE ON THEM.

All other creditors of the decedent and other persons having claims or demands against decedent's estate must file their claims with this court WITHIN 3 MONTHS AFTER THE DATE OF THE FIRST PUBLICATION OF THIS NOTICE.

ALL CLAIMS NOT FILED WITHIN THE TIME PERIODS SET FORTH IN SECTION 733.702 OF THE FLORIDA PROBATE CODE WILL BE FOREVER BARRED.

NOTWITHSTANDING THE TIME PERIOD SET FORTH ABOVE, ANY CLAIM FILED TWO (2) YEARS OR MORE AFTER THE DECEDENT'S DATE OF DEATH IS BARRED.

The date of first publication of this notice is Dec. 20, 2013.

J. Geoffrey Pflugner

Personal Representative

c/o Todd D. Kaplan

Icard, Merrill, Cullis, Timm, Furen,

& Ginsburg, P.A.

8470 Enterprise Circle, Suite 201

Bradenton, FL 34202

Telephone: 941-907-0006

Fax: 941-487-5371

Todd D. Kaplan

Attorney for Personal Representative

Email: tkaplan@icardmerrill.com

Florida Bar No. 0613371

Icard, Merrill, Cullis, Timm, Furen,

& Ginsburg, P.A.

8470 Enterprise Circle,

Suite 201

Bradenton, FL 34202

Telephone: 941-907-0006

Fax: 941-487-5371

December 20, 27, 2013 13-05963S

FIRST INSERTION

NOTICE TO CREDITORS
IN THE CIRCUIT COURT FOR
SARASOTA COUNTY, FLORIDA
PROBATE DIVISION
File No. 2013 CP 4618 NC
Division Probate
IN RE: ESTATE OF
MONICA THOMSON
Deceased.

The administration of the estate of MONICA THOMSON, deceased, whose date of death was April 3, 2013, is pending in the Circuit Court for Sarasota County, Florida, Probate Division, the address of which is 2000 Main Street, Sarasota, Florida 34230. The names and addresses of the personal representative and the personal representative's attorney are set forth below.

All creditors of the decedent and other persons having claims or demands against decedent's estate on whom a copy of this notice is required to be served must file their claims with this court WITHIN THE LATER OF 3 MONTHS AFTER THE TIME OF THE FIRST PUBLICATION OF THIS NOTICE OR 30 DAYS AFTER THE DATE OF SERVICE OF A COPY OF THIS NOTICE ON THEM.

All other creditors of the decedent and other persons having claims or demands against decedent's estate must file their claims with this court WITHIN 3 MONTHS AFTER THE DATE OF THE FIRST PUBLICATION OF THIS NOTICE.

ALL CLAIMS NOT FILED WITHIN THE TIME PERIODS SET FORTH IN SECTION 733.702 OF THE FLORIDA PROBATE CODE WILL BE FOREVER BARRED.

NOTWITHSTANDING THE TIME PERIODS SET FORTH ABOVE, ANY CLAIM FILED TWO (2) YEARS OR MORE AFTER THE DECEDENT'S DATE OF DEATH IS BARRED.

The date of first publication of this notice is December 20, 2013.

Personal Representative:

Edwin M. Boyer

C/O Boyer, Jackson, Bowman

& Boyer P.A.

46 N. Washington Blvd., Ste. 21

Sarasota, Florida 34236

Edwin M. Boyer, Esq.

Attorney

Florida Bar Number: 0252719

BOYER, JACKSON, BOWMAN &

BOYER, P.A.

46 No. Washington Blvd., Ste 21

Sarasota, FL 34236

Telephone: (941) 365-2304

E-Mail: aboyer@boyerjackson.com

Fax: (941) 364-9896

E-Mail: emboyer@boyerjackson.com

December 20, 27, 2013 13-05975S

FIRST INSERTION

NOTICE TO CREDITORS
IN THE CIRCUIT COURT FOR
SARASOTA COUNTY, FLORIDA
PROBATE DIVISION
File: 2013-CP-004537-SC
Division Probate
IN RE: ESTATE OF
MILDRED FELLIN
Deceased.

The administration of the estate of Mildred Fellin, deceased, whose date of death was November 12, 2013, is pending in the Circuit Court for Sarasota County, Florida, Probate Division, the address of which is PO Box 3079, Sarasota, Florida 34230. The names and addresses of the personal representative and the personal representative's attorney are set forth below.

All creditors of the decedent and other persons having claims or demands against decedent's estate on whom a copy of this notice is required to be served must file their claims with this court WITHIN THE LATER OF 3 MONTHS AFTER THE TIME OF THE FIRST PUBLICATION OF THIS NOTICE OR 30 DAYS AFTER THE DATE OF SERVICE OF A COPY OF THIS NOTICE ON THEM.

All other creditors of the decedent and other persons having claims or demands against decedent's estate must file their claims with this court WITHIN 3 MONTHS AFTER THE DATE OF THE FIRST PUBLICATION OF THIS NOTICE.

ALL CLAIMS NOT FILED WITHIN THE TIME PERIODS SET FORTH IN SECTION 733.702 OF THE FLORIDA PROBATE CODE WILL BE FOREVER BARRED.

NOTWITHSTANDING THE TIME PERIODS SET FORTH ABOVE, ANY CLAIM FILED TWO (2) YEARS OR MORE AFTER THE DECEDENT'S DATE OF DEATH IS BARRED.

The date of first publication of this notice is December 20, 2013.

Personal Representative:

John J. Fellin

832 Diane Circle

Englewood, Florida 34223

Attorney for Personal Representative:

Charles Diez, Jr.

Attorney for John J. Fellin

Florida Bar Number: 0196446

Diez & Floyd, P.A.

737 South Indiana Avenue

Suite A

Englewood, FL 34223

Telephone: (941) 474-5506

Fax: (941) 474-5507

E-Mail: diezandfloyd@a

diezandfloydpa.comcastbiz.net

December 20, 27, 2013 13-05912S

FIRST INSERTION

NOTICE TO CREDITORS
IN THE CIRCUIT COURT FOR
SARASOTA COUNTY, FLORIDA
PROBATE DIVISION
File No. 2013 CP 4659 NC
Division Probate
IN RE: ESTATE OF
JACOB WEINTRAUB
Deceased.

The administration of the estate of Jacob Weintraub, deceased, whose date of death was May 28, 2013, is pending in the Circuit Court for Sarasota County, Florida, Probate Division, the address of which is 2000 Main Street, Sarasota, FL 34237. The names and addresses of the personal representative and the personal representative's attorney are set forth below.

All creditors of the decedent and other persons having claims or demands against decedent's estate on whom a copy of this notice is required to be served must file their claims with this court WITHIN THE LATER OF 3 MONTHS AFTER THE TIME OF THE FIRST PUBLICATION OF THIS NOTICE OR 30 DAYS AFTER THE DATE OF SERVICE OF A COPY OF THIS NOTICE ON THEM.

All other creditors of the decedent and other persons having claims or demands against decedent's estate must file their claims with this court WITHIN 3 MONTHS AFTER THE DATE OF THE FIRST PUBLICATION OF THIS NOTICE.

ALL CLAIMS NOT FILED WITHIN THE TIME PERIODS SET FORTH IN SECTION 733.702 OF THE FLORIDA PROBATE CODE WILL BE FOREVER BARRED.

NOTWITHSTANDING THE TIME PERIODS SET FORTH ABOVE, ANY CLAIM FILED TWO (2) YEARS OR MORE AFTER THE DECEDENT'S DATE OF DEATH IS BARRED.

The date of first publication of this notice is December 20, 2013.

Personal Representative:

Frances Weintraub

Petitioner

Attorney for Personal Representative:

Ira S. Wiesner

Attorney for Petitioner

Florida Bar Number: 222887

Professional Association,

Advocates in Aging

328 N. Rhodes Avenue

Sarasota, Florida 34237

Telephone: (941) 365-9900

Fax: (941) 365-4479

E-Mail: advocates@wiesnerlaw.com

Secondary E-Mail:

sarah@wiesnerlaw.com

December 20, 27, 2013 13-05978S

FIRST INSERTION

NOTICE TO CREDITORS
IN THE CIRCUIT COURT FOR
SARASOTA COUNTY, FLORIDA
PROBATE DIVISION
File No. 2013CP004696NC
Division PROBATE
IN RE: ESTATE OF
PEGGY L. ALBRITTON,
Deceased.

The administration of the estate of PEGGY L. ALBRITTON, deceased, whose date of death was November 13, 2013, is pending in the Circuit Court for Sarasota County, Florida, Probate Division, the address of which is Clerk of Circuit Court, Post Office Box 3079, Sarasota, FL 34230. The names and addresses of the trustees and the trustees' attorney are set forth below.

All creditors of the decedent and other persons having claims or demands against decedent's estate on whom a copy of this notice is required to be served must file their claims with this court WITHIN THE LATER OF 3 MONTHS AFTER THE TIME OF THE FIRST PUBLICATION OF THIS NOTICE OR 30 DAYS AFTER THE DATE OF SERVICE OF A COPY OF THIS NOTICE ON THEM.

All other creditors of the decedent and other persons having claims or demands against decedent's estate must file their claims with this court WITHIN 3 MONTHS AFTER THE DATE OF THE FIRST PUBLICATION OF THIS NOTICE.

ALL CLAIMS NOT FILED WITHIN THE TIME PERIODS SET FORTH IN SECTION 733.702 OF THE FLORIDA PROBATE CODE WILL BE FOREVER BARRED.

NOTWITHSTANDING THE TIME PERIOD SET FORTH ABOVE, ANY CLAIM FILED TWO (2) YEARS OR MORE AFTER THE DECEDENT'S DATE OF DEATH IS BARRED.

The date of first publication of this notice is December 20, 2013.

Trustees:

Robert C. Albritton, Jr.

Address: 3692 Walden Pond Drive

Sarasota, FL 34240

Linda Gail Strong

Address: 4167 Malden Drive

Sarasota, FL 34241

Attorney for Trustees:

Attorney Name: Charles H. Ball, Esq.

Florida Bar #160370

Address: 1444 1st St.

Sarasota, FL 34236

Telephone Number: 941-952-1500

Fax Number: 941-953-5736

December 20, 27, 2013 13-05962S

FIRST INSERTION

NOTICE TO CREDITORS
IN THE CIRCUIT COURT FOR
SARASOTA COUNTY, FLORIDA
PROBATE DIVISION
File # 2013CP004671NC
Division PROBATE
IN RE: ESTATE OF
EDWARD O. STEINWACHS
Deceased.

The administration of the estate of EDWARD O. STEINWACHS, deceased, whose date of death was October 27, 2013, is pending in the Circuit Court for SARASOTA County, Florida, Probate Division, the address of which is P.O. Box 3079, Sarasota, FL 34230. The names and addresses of the personal representative and the personal representative's attorney are set forth below.

All creditors of the decedent and other persons having claims or demands against decedent's estate on whom a copy of this notice is required to be served must file their claims with this court WITHIN THE LATER OF 3 MONTHS AFTER THE TIME OF THE FIRST PUBLICATION OF THIS NOTICE OR 30 DAYS AFTER THE DATE OF SERVICE OF A COPY OF THIS NOTICE ON THEM.

All other creditors of the decedent and other persons having claims or demands against decedent's estate must file their claims with this court WITHIN 3 MONTHS AFTER THE DATE OF THE FIRST PUBLICATION OF THIS NOTICE.

ALL CLAIMS NOT FILED WITHIN THE TIME PERIODS SET FORTH IN SECTION 733.702 OF THE FLORIDA PROBATE CODE WILL BE FOREVER BARRED.

NOTWITHSTANDING THE TIME PERIODS SET FORTH ABOVE, ANY CLAIM FILED TWO (2) YEARS OR MORE AFTER THE DECEDENT'S DATE OF DEATH IS BARRED.

The date of first publication of this notice is December 20, 2013.

Personal Representative:

DONALD E. STEINWACHS

3420 Gulfmead Drive

Sarasota, Florida 34242

Attorney for Personal Representative:

JONATHAN T. ANDERSON

Attorney for DONALD E.

STEINWACHS

WOOD, SEITL & ANDERSON, P.A.

Florida Bar Number: 188530

3665 Bee Ridge Road, Suite 300

Sarasota, FL 34233

Telephone: (941) 954-5772

Fax: (941) 925-9164

E-Mail: jonathan@wsa-law.com

December 20, 27, 2013 13-05979S

FIRST INSERTION

Notice to Creditors
IN THE CIRCUIT COURT OF THE
TWELFTH JUDICIAL CIRCUIT IN
AND FOR SARASOTA COUNTY,
FLORIDA
PROBATE DIVISION
CASE NO. 2013 CP 003794 NC
In re the Estate of:
MILLER, DAVID F.
Deceased.

The ancillary administration of the estate of DAVID F. MILLER, deceased, whose date of death was May 18, 2012, is pending in the Twelfth Circuit Court for Sarasota County, Florida Probate Division, the address of which is 2000 Main Street, Sarasota Florida, 34237. The estate is testate. The names and addresses of the personal representative and the personal representative's attorney are set forth below.

All creditors of the decedent and other persons having claims or demands against decedent's estate on whom a copy of this notice is required to be served must file their claims with this court WITHIN THE LATER OF 3 MONTHS AFTER THE DATE OF THE FIRST PUBLICATION OF THIS NOTICE OR 30 DAYS AFTER THE DATE OF SERVICE OF A COPY OF THIS NOTICE ON THEM.

All other creditors of the decedent and other persons having claims or demands against decedent's estate must file their claims with this court WITHIN 3 MONTHS AFTER THE DATE OF THE FIRST PUBLICATION OF THIS NOTICE.

ALL CLAIMS NOT SO FILED WILL BE FOREVER BARRED.

NOTWITHSTANDING THE TIME PERIOD SET FORTH ABOVE, ANY CLAIM FILED TWO (2) YEARS OR MORE AFTER THE DECEDENT'S DATE OF DEATH IS BARRED.

The date of the first publication of this Notice is December 20, 2013

Personal Representative:

Diane A. Miller

4 Summit Place

Croton, NY 10520

Attorney for Personal Representative:

Jeffrey A. King, Esq.

Florida Bar No. 342238

1800 Second Street, Suite 895

Sarasota, Florida 34236

Telephone: (941) 954-5585

Email: bravesfan51@aol.com

December 20, 27, 2013 13-05913S

FIRST INSERTION

NOTICE TO CREDITORS
IN THE CIRCUIT COURT FOR
SARASOTA COUNTY, FLORIDA
PROBATE DIVISION
File No.: 2013-CP-004007-NC
IN RE: ESTATE OF
JEANNETTE C. JUDGE
Deceased.

The administration of the estate of JEANNETTE C. JUDGE, deceased, File no.: 2013-CP-004007-NC, is pending in the Circuit Court for Sarasota County, Florida, Probate Division, the address of which is P.O. Box 3079, Sarasota, FL 34230. The names and addresses of the personal representative and the personal representative's attorney are set forth below.

All creditors of the decedent and other persons having claims or demands against decedent's estate, including unmaturred, contingent or unliquidated claims, or whom a copy of this notice is served must file their claims with this court WITHIN THE LATER OF THREE (3) MONTHS AFTER THE DATE OF THE FIRST PUBLICATION OF THIS NOTICE OR THIRTY (30) DAYS AFTER THE DATE OF SERVICE OF A COPY OF THIS NOTICE ON THEM.

All other creditors of the decedent and other persons

FIRST INSERTION

NOTICE TO CREDITORS
IN THE CIRCUIT COURT FOR
SARASOTA COUNTY, FLORIDA
PROBATE DIVISION
File No. 2013 CP 4571 NC
IN RE: ESTATE OF
WILLIAM A. DOYLE
Deceased.

The administration of the estate of WILLIAM A. DOYLE, deceased, whose date of death was October 29, 2013; File Number 2013 CP 4571 NC, is pending in the Circuit Court for Sarasota County, Florida, Probate Division, the address of which is 2000 Main St., Sarasota, FL 34237. The names and addresses of the personal representative and the personal representative's attorney are set forth below.

All creditors of the decedent and other persons having claims or demands against decedent's estate, on whom a copy of this notice is required to be served must file their claims with this court ON OR BEFORE THE LATER OF 3 MONTHS AFTER THE TIME OF THE FIRST PUBLICATION OF THIS NOTICE OR 30 DAYS AFTER THE DATE OF SERVICE OF A COPY OF THIS NOTICE ON THEM.

All other creditors of the decedent and other persons having claims or demands against decedent's estate must file their claims with this court WITHIN 3 MONTHS AFTER THE DATE OF THE FIRST PUBLICATION OF THIS NOTICE.

ALL CLAIMS NOT FILED WITHIN THE TIME PERIODS SET FORTH IN SECTION 733.702 OF THE FLORIDA PROBATE CODE WILL BE FOREVER BARRED.

NOTWITHSTANDING THE TIME PERIOD SET FORTH ABOVE, ANY CLAIM FILED TWO (2) YEARS OR MORE AFTER THE DECEDENT'S DATE OF DEATH IS BARRED.

The date of first publication of this notice is: December 20, 2013.

GREGORY F. DOYLE
Personal Representative
c/o Michael L. Foreman
Email: mforeman@icardmerrill.com
Florida Bar No. 118485
Icard, Merrill, Cullis,
Timm, Furen & Ginsburg, P.A.
2033 Main St., Suite 600
Sarasota, FL 34237
Telephone: 941-366-8100;
Fax: 941-366-6384

Michael L. Foreman
Attorney for Personal Representative
Email: mforeman@icardmerrill.com
Florida Bar No. 118485
Icard, Merrill, Cullis,
Timm, Furen & Ginsburg, P.A.
2033 Main St.,
Suite 600
Sarasota, FL 34237
Telephone: 941-366-8100
Fax: 941-366-6384

December 20, 27, 2013 13-05977S

FIRST INSERTION

NOTICE OF PUBLIC SALE OF
PERSONAL PROPERTY

Notice is hereby given that the undersigned will sell, to satisfy lien of the owner, at public sale by Competitive bidding on 01-09-2014 at 9:30 am at the Extra Space Storage facility located at:

4173 Clark Road Sarasota, FL 34233
941-925-4006

The personal goods stored therein by the following may include, but are not limited to general household, furniture, boxes, clothes, and appliances.

568 Cindy Brown-Furniture, 96 Joyce Neegele-Furniture, 16 William Walker Jr-Household Items, 462 Angela Adams-Furniture, 991 Bouazzouli Adil-Flowers, 117 Casie Porter-Personal, 833 Stephen Testa-Furniture

Purchases must be made with cash only and paid at the time of sale. All goods are sold as is and must be removed at the time of purchase. Extra Space Storage reserves the right to bid. Sale is subject to adjournment.

December 20, 27, 2013 13-05948S

FIRST INSERTION

NOTICE OF PUBLIC SALE

In accordance with Florida State Law Self Storage Facility Act 83.801-83.809, ss.4(a) and to satisfy an operator's lien, the contents of the following units will be sold at a public auction to the highest bidder for cash on or thereafter:

Date: Jan. 9th, 2014
Time: 3:00 p.m., or after
At: Patriot Self Storage, 2245 Bobcat Village Center Rd., North Port, FL 34288
Unit# - 1027, Garry Tarazie Burks, furniture and personal
Unit# - 2301, Edward Owen Engquist III, household and personal.
Patriot Self Storage reserves the right to cancel the sale at any time for any reason.

December 20, 27, 2013 13-05997S

FIRST INSERTION

NOTICE TO CREDITORS
IN THE CIRCUIT COURT FOR
SARASOTA COUNTY, FLORIDA
PROBATE DIVISION
File # 2013CP004670NC
Division PROBATE
IN RE: ESTATE OF
MARGARET B. STEINWACHS
Deceased

The administration of the estate of MARGARET B. STEINWACHS, deceased, whose date of death was November 16, 2013, is pending in the Circuit Court for SARASOTA County, Florida, Probate Division, the address of which is P.O. Box 3079, Sarasota, FL 34230. The names and addresses of the personal representative and the personal representative's attorney are set forth below.

All creditors of the decedent and other persons having claims or demands against decedent's estate on whom a copy of this notice is required to be served must file their claims with this court WITHIN THE LATER OF 3 MONTHS AFTER THE TIME OF THE FIRST PUBLICATION OF THIS NOTICE OR 30 DAYS AFTER THE DATE OF SERVICE OF A COPY OF THIS NOTICE ON THEM.

All other creditors of the decedent and other persons having claims or demands against decedent's estate must file their claims with this court WITHIN 3 MONTHS AFTER THE DATE OF THE FIRST PUBLICATION OF THIS NOTICE.

ALL CLAIMS NOT FILED WITHIN THE TIME PERIODS SET FORTH IN SECTION 733.702 OF THE FLORIDA PROBATE CODE WILL BE FOREVER BARRED.

NOTWITHSTANDING THE TIME PERIODS SET FORTH ABOVE, ANY CLAIM FILED TWO (2) YEARS OR MORE AFTER THE DECEDENT'S DATE OF DEATH IS BARRED.

The date of first publication of this notice is December 20, 2013.

Personal Representative:
DONALD E. STEINWACHS
3420 Gulfmead Drive
Sarasota, Florida 34242
Attorney for Personal Representative:
JONATHAN T. ANDERSON
Attorney for DONALD E.
STEINWACHS
WOOD, SEITL & ANDERSON, P.A.
Florida Bar Number: 188530
3665 Bee Ridge Road, Suite 300
Sarasota, FL 34233
Telephone: (941) 954-5772
Fax: (941) 925-9164
E-Mail: jonathan@wsa-law.com
December 20, 27, 2013 13-05980S

FIRST INSERTION

NOTICE TO CREDITORS
IN THE CIRCUIT COURT FOR
SARASOTA COUNTY, FLORIDA
PROBATE DIVISION
File No. 2013 CP 4582 NC
IN RE: ESTATE OF
WESLEY J. REYNOLDS
Deceased.

The administration of the estate of WESLEY J. REYNOLDS, deceased, whose date of death was November 23, 2013, is pending in the Circuit Court for SARASOTA County, Florida, Probate Division, the address of which is P.O. Box 3079, Sarasota, Florida 34230-3079. The names and addresses of the personal representative and the personal representative's attorney are set forth below.

All creditors of the decedent and other persons having claims or demands against decedent's estate on whom a copy of this notice is required to be served must file their claims with this court WITHIN THE LATER OF 3 MONTHS AFTER THE TIME OF THE FIRST PUBLICATION OF THIS NOTICE OR 30 DAYS AFTER THE DATE OF SERVICE OF A COPY OF THIS NOTICE ON THEM.

All other creditors of the decedent and other persons having claims or demands against decedent's estate must file their claims with this court WITHIN 3 MONTHS AFTER THE DATE OF THE FIRST PUBLICATION OF THIS NOTICE.

ALL CLAIMS NOT FILED WITHIN THE TIME PERIODS SET FORTH IN SECTION 733.702 OF THE FLORIDA PROBATE CODE WILL BE FOREVER BARRED.

NOTWITHSTANDING THE TIME PERIOD SET FORTH ABOVE, ANY CLAIM FILED TWO (2) YEARS OR MORE AFTER THE DECEDENT'S DATE OF DEATH IS BARRED.

The date of first publication of this notice is December 20, 2013.

Personal Representative:
JAMES T. ALCOCK
44216 Brandywyne Road
Canton, Michigan 48187
Attorney for Personal Representative:
EUGENE O. GEORGE
E-Mail:
egeoorge@bowmangeorge.com
Florida Bar No. 127285
BOWMAN, GEORGE, SCHEB,
KIMBROUGH & KOACH, P.A.
2750 Ringling Blvd., Suite 3
Sarasota, Florida 34237
Telephone: (941) 366-5510
December 20, 27, 2013 13-06004S

FIRST INSERTION

NOTICE TO CREDITORS
IN THE CIRCUIT COURT FOR
SARASOTA COUNTY, FLORIDA
PROBATE DIVISION
File No. 13-3728
IN RE: ESTATE OF
Louise Clark Grimes
Deceased.

The administration of the Louise Clark Grimes, deceased, whose date of death was May 21, 2013, and whose social security number is .../1238, is pending in the Circuit Court for Sarasota County, Florida, Probate Division, the address of which is 2000 Main Street, Sarasota, FL 34237. The names and addresses of the personal representative and the personal representative's attorney are set forth below.

All creditors of the decedent and other persons having claims or demands against decedent's estate on whom a copy of this notice is required to be served must file their claims with this court WITHIN THE LATER OF 3 MONTHS AFTER THE TIME OF THE FIRST PUBLICATION OF THIS NOTICE OR 30 DAYS AFTER THE DATE OF SERVICE OF A COPY OF THIS NOTICE ON THEM.

All other creditors of the decedent and other persons having claims or demands against decedent's estate must file their claims with this court WITHIN 3 MONTHS AFTER THE DATE OF THE FIRST PUBLICATION OF THIS NOTICE.

ALL CLAIMS NOT FILED WITHIN THE TIME PERIODS SET FORTH IN SECTION 733.702 OF THE FLORIDA PROBATE CODE WILL BE FOREVER BARRED.

NOTWITHSTANDING THE TIME PERIOD SET FORTH ABOVE, ANY CLAIM FILED TWO (2) YEARS OR MORE AFTER THE DECEDENT'S DATE OF DEATH IS BARRED.

The date of first publication of this notice is December 20, 2013.

Personal Representative:
Louis Charles Grimes
2731 Lamplighter Drive
Sarasota, Florida 34234

Attorney for Personal Representative:
Charles A. Goff
E-Mail Address: casogoff3@aol.com
Florida Bar No. 137187
Casoria & Goff, P.A.
1040 Bayview Drive, #422
Ft. Lauderdale, Florida 33304
Telephone: (954) 564-4600
December 20, 27, 2013 13-05976S

FIRST INSERTION

NOTICE TO CREDITORS
IN THE CIRCUIT COURT FOR
SARASOTA COUNTY, FLORIDA
PROBATE DIVISION
File No. 2013 CP 004712 NC
Division PR
IN RE: ESTATE OF
JAMES F. PIPPENGER
Deceased.

The administration of the estate of JAMES F. PIPPENGER, deceased, whose date of death was September 28, 2013, is pending in the Circuit Court for Sarasota County, Florida, Probate Division, the address of which is P. O. Box 3079, Sarasota, Florida 34230-3079. The names and addresses of the personal representative and the personal representative's attorney are set forth below.

All creditors of the decedent and other persons having claims or demands against decedent's estate on whom a copy of this notice is required to be served must file their claims with this court WITHIN THE LATER OF 3 MONTHS AFTER THE TIME OF THE FIRST PUBLICATION OF THIS NOTICE OR 30 DAYS AFTER THE DATE OF SERVICE OF A COPY OF THIS NOTICE ON THEM.

All other creditors of the decedent and other persons having claims or demands against decedent's estate must file their claims with this court WITHIN 3 MONTHS AFTER THE DATE OF THE FIRST PUBLICATION OF THIS NOTICE.

ALL CLAIMS NOT FILED WITHIN THE TIME PERIODS SET FORTH IN SECTION 733.702 OF THE FLORIDA PROBATE CODE WILL BE FOREVER BARRED.

NOTWITHSTANDING THE TIME PERIODS SET FORTH ABOVE, ANY CLAIM FILED TWO (2) YEARS OR MORE AFTER THE DECEDENT'S DATE OF DEATH IS BARRED.

The date of first publication of this notice is December 20, 2013.

Personal Representative:
Louise A. Pippenger
5551 Dunrobin Drive Unit 4108
Sarasota, Florida 34238
Attorney for Personal Representative:
Kent J. Anderson
Attorney
Florida Bar Number: 0252638
KENT J. ANDERSON, P.A.
7101 South Tamiami Trail, Suite A
Sarasota, Florida 34231-5556
Telephone: (941) 923-2771
Fax: (941)923-2774
E-Mail:
kanderson@amtlaw.com
Secondary E-Mail: None
December 20, 27, 2013 13-06003S

FIRST INSERTION

NOTICE TO CREDITORS
IN THE CIRCUIT COURT FOR
SARASOTA COUNTY, FLORIDA
PROBATE DIVISION
File No. 2013-CP 004569 NC
IN RE: ESTATE OF
MARY M. WAGONER
Deceased.

The administration of the estate of MARY M. WAGONER, deceased, whose date of death was October 31, 2013; File Number 2013-CP 004569 NC, is pending in the Circuit Court for Sarasota County, Florida, Probate Division, the address of which is P.O. Box 3079, Sarasota FL 34230-3079. The names and addresses of the personal representative and the personal representative's attorney are set forth below.

All creditors of the decedent and other persons having claims or demands against decedent's estate, on whom a copy of this notice is required to be served must file their claims with this court WITHIN THE LATER OF 3 MONTHS AFTER THE TIME OF THE FIRST PUBLICATION OF THIS NOTICE OR 30 DAYS AFTER THE DATE OF SERVICE OF A COPY OF THIS NOTICE ON THEM.

All other creditors of the decedent and other persons having claims or demands against decedent's estate must file their claims with this court WITHIN 3 MONTHS AFTER THE DATE OF THE FIRST PUBLICATION OF THIS NOTICE.

ALL CLAIMS NOT FILED WITHIN THE TIME PERIODS SET FORTH IN SECTION 733.702 OF THE FLORIDA PROBATE CODE WILL BE FOREVER BARRED.

NOTWITHSTANDING THE TIME PERIOD SET FORTH ABOVE, ANY CLAIM FILED TWO (2) YEARS OR MORE AFTER THE DECEDENT'S DATE OF DEATH IS BARRED.

The date of first publication of this notice is: December 20, 2013.

ELIZABETH SWIFT
Personal Representative
48 Catfish Lane
Lake Placid FL 33852

H. Greg Lee
Attorney for Personal Representative
Email: hglee@hgree.com
Florida Bar No. 0351301
H. GREG LEE, P.A.
2014 Fourth Street
Sarasota, FL 34237
Telephone: (941) 954-0067
Facsimile: (941) 365-1492
December 20, 27, 2013 13-05931S

FIRST INSERTION

NOTICE OF SALE
IN THE CIRCUIT COURT OF THE
TWELFTH JUDICIAL CIRCUIT OF
THE STATE OF FLORIDA, IN AND
FOR SARASOTA COUNTY
CIVIL DIVISION
CASE NO.

58-2009-CA-010271-XXXX-NC
SUNTRUST MORTGAGE, INC.,
Plaintiff, vs.
RICHARD S. SIMS; MORTGAGE
ELECTRONIC REGISTRATION
SYSTEMS INCORPORATED,
ACTING SOLELY AS NOMINEE
FOR SUNTRUST MORTGAGE,
INC.; PAMELA BETTIS SIMS;
UNKNOWN TENANT(S);
Defendant(s)

Notice is hereby given that, pursuant to a Final Summary Judgment of Foreclosure entered on 09/17/2013 in the above styled cause, in the Circuit Court of Sarasota County, Florida, the office of Karen E. Rushing clerk of the circuit court will sell the property situate in Sarasota County, Florida, described as:

LOT 42, BLOCK 6, VENICE EAST, SECTION ONE, ACCORDING TO THE PLAT THEREOF, AS RECORDED IN PLAT BOOK 12, PAGE 13, OF THE PUBLIC RECORDS OF SARASOTA COUNTY, FLORIDA.

at public sale, to the highest and best bidder, for cash, www.sarasota.realforeclose.com at 9:00 o'clock, A.M., on January 15, 2014

Any person claiming an interest in the surplus from the sale, if any, other than the property owner as of the date of the lis pendens, must file a claim within 60 days after the sale.

If you are a person with a disability who needs any accommodation in order to participate in this proceeding, you are entitled, at no cost to you, to the provision of certain assistance. Please contact the Sarasota County Jury Office, P.O. Box 3079, Sarasota, Florida 34230-3079, (941)861-7400, at least seven (7) days before your scheduled court appearance, or immediately upon receiving this notification if the time before the scheduled appearance is less than seven (7) days; if you are hearing or voice impaired, call 711.

ATTORNEY FOR PLAINTIFF
By Josh D. Donnelly
Florida Bar #64788

Date: 12/17/2013
THIS INSTRUMENT PREPARED BY:
Law Offices Of Daniel C. Consuegra
9204 King Palm Drive
Tampa, FL 33619-1328
Phone: 813-915-8660
Attorneys for Plaintiff
139705-T
December 20, 27, 2013 13-05988S

FIRST INSERTION

NOTICE OF FORECLOSURE SALE
IN THE CIRCUIT COURT OF THE
12TH JUDICIAL CIRCUIT, IN
AND FOR SARASOTA COUNTY,
FLORIDA

CIVIL DIVISION:
CASE NO.: 58-2010-CA-001751 NC
AURORA LOAN SERVICES, LLC,
Plaintiff, vs.
HARVEY JOHN HOWARD;
BANK OF AMERICA, N.A.; THE
UNKNOWN SPOUSE OF HARVEY
JOHN HOWARD; UNKNOWN
TENANT(S); IN POSSESSION OF
THE SUBJECT PROPERTY,
Defendants.

NOTICE IS HEREBY GIVEN pursuant to Final Judgment of Foreclosure dated the 3rd day of December, 2013, and entered in Case No. 58-2010-CA-001751 NC, of the Circuit Court of the 12TH Judicial Circuit in and for Sarasota County, Florida, wherein AURORA LOAN SERVICES, LLC is the Plaintiff and HARVEY JOHN HOWARD; BANK OF AMERICA, N.A. and UNKNOWN TENANT(S); IN POSSESSION OF THE SUBJECT PROPERTY are defendants. The Clerk of this Court shall sell to the highest and best bidder for cash electronically at www.sarasota.realforeclose.com at 9:00 AM on the 13th day of January, 2014, the following described property as set forth in said Final Judgment, to wit:

LOT 2485, SARASOTA SPRINGS, UNIT NO. 21, ACCORDING TO THE PLAT THEREOF RECORDED IN

PLAT BOOK PAGE 80, OF THE PUBLIC RECORDS OF SARASOTA COUNTY, FLORIDA.

ANY PERSON CLAIMING AN INTEREST IN THE SURPLUS FROM THE SALE, IF ANY, OTHER THAN THE PROPERTY OWNER AS OF THE DATE OF THE LIS PENDENS MUST FILE A CLAIM WITHIN 60 DAYS AFTER THE SALE.

If you are a person with a disability who needs any accommodation in order to participate in this proceeding, you are entitled, at no cost to you, to the provision of certain assistance. Please contact the Sarasota County Jury Office, P.O. Box 3079, Sarasota, Florida 34230-3079, (941)861-7400, at least seven (7) days before your scheduled court appearance, or immediately upon receiving this notification if the time before the scheduled appearance is less than seven (7) days; if you are hearing or voice impaired, call 711.

Dated this 17 day of December, 2013.

By: Michael D.P. Phillips
Bar #653268

Choice Legal Group, P.A.
1800 NW 49th Street, Suite 120
Fort Lauderdale, Florida 33309
Telephone: (954) 453-0365
Facsimile: (954) 771-6052
Toll Free: 1-800-441-2438
DESIGNATED PRIMARY E-MAIL
FOR SERVICE PURSUANT TO FLA
R. JUD. ADMIN 2.516
eservice@legallgroup.com
10-05575
December 20, 27, 2013 13-05998S

FIRST INSERTION

NOTICE OF SALE
IN THE CIRCUIT COURT OF THE
TWELFTH JUDICIAL CIRCUIT OF
THE STATE OF FLORIDA, IN AND
FOR SARASOTA COUNTY
CIVIL DIVISION
CASE NO.

58-2009-CA-000458-XXXX-NC
U.S. BANK NATIONAL
ASSOCIATION, AS TRUSTEE
FOR TBW MORTGAGE-BACKED
TRUST SERIES 2006-3,
MORTGAGE-BACKED
PASS-THROUGH CERTIFICATES,
SERIES 2006-3,,
Plaintiff, vs.

JOSHUA SCHROCK; THE
UNKNOWN SPOUSE OF
JOSHUA SCHROCK; IF
LIVING, INCLUDING ANY
UNKNOWN SPOUSE OF SAID
DEFENDANT(S), IF REMARRIED,
AND IF DECEASED, THE
RESPECTIVE UNKNOWN
HEIRS, DEVISEES, GRANTEEES,
ASSIGNEES, CREDITORS,
LIENORS, AND TRUSTEES,
AND ALL OTHER PERSONS
CLAIMING BY, THROUGH,
UNDER OR AGAINST THE
NAMED DEFENDANT(S);
BRANCH BANKING AND
TRUST COMPANY; THE DUCK
KEY OWNERS' ASSOCIATION,
INC.; WHETHER DISSOLVED
OR PRESENTLY EXISTING,
TOGETHER WITH ANY
GRANTEES, ASSIGNEES,
CREDITORS, LIENORS,
OR TRUSTEES OF SAID
DEFENDANT(S) AND ALL
OTHER PERSONS CLAIMING
BY, THROUGH, UNDER, OR
AGAINST DEFENDANT(S);
UNKNOWN TENANT #1;
UNKNOWN TENANT #2;
Defendant(s)

Notice is hereby given that, pursuant to a Final Summary Judgment of Foreclosure entered on 12/04/2013 in the above styled cause, in the Circuit Court of Sarasota County, Florida, the office of Karen E. Rushing clerk of the circuit court will sell the property situate in Sarasota County, Florida, described as:

LOT 28, Block 23, 13TH ADDITION TO PORT CHARLOTTE SUBDIVISION, according to the plat thereof, as recorded in Plat Book 13, Page 12, of the Public Records of Sarasota County, Florida.

at public sale, to the highest and best bidder, for cash, www.sarasota.realforeclose.com at 9:00 o'clock, A.M., on January 14, 2014

Any person claiming an interest in the surplus from the sale, if any, other than the property owner as of the date of the lis pendens, must file a claim within 60 days after the sale.

If you are a person with a disability who needs any accommodation in order to participate in this proceeding, you are entitled, at no cost to you, to the provision of certain assistance. Please contact the Sarasota County Jury Office, P.O. Box 3079, Sarasota, Florida 34230-3079, (941)861-7400, at least seven (7) days before your scheduled court appearance, or immediately upon receiving this notification if the time before the scheduled appearance is less than seven (7) days; if you are hearing or voice impaired, call 711.

ATTORNEY FOR PLAINTIFF
By Josh D. Donnelly
Florida Bar #64788

Date: 12/17/2013
THIS INSTRUMENT PREPARED BY:
Law Offices Of Daniel C. Consuegra
9204 King Palm Drive
Tampa, FL 33619-1328
Phone: 813-915-8660
Attorneys for Plaintiff
139705-T
December 20, 27, 2013 13-05990S

FIRST INSERTION

NOTICE OF SALE
IN THE CIRCUIT COURT OF THE
TWELFTH JUDICIAL CIRCUIT
IN AND FOR SARASOTA COUNTY,
FLORIDA

Case No. 2013 CA 002369 NC
VILLAGIO CONDOMINIUM
ASSOCIATION, INC., a Florida
not-for-profit corporation,
Plaintiff, v.

CAROL A. MCCONWAY A/K/A
CAROL MCCONWAY, DECEASED,
AND ANY UNKNOWN PARTY
WHO MAY CLAIM AS HEIR,
DEVISEE, GRANTEE, ASSIGNEE,
LIENOR, CREDITOR,
TRUSTEE OR OTHER CLAIMANT,
BY, THROUGH, UNDER OR
AGAINST CAROL MCCONWAY
A/K/A CAROL MCCONWAY;
JOHN D. MCCONWAY; DENIS
MCCONWAY, JR.; ALLISON
LEIGH MCCONWAY,
Defendants.

Notice is hereby given pursuant to the Summary Final Judgment of foreclosure entered in the above-styled Case Number 2013 CA 002369 NC, in the Circuit Court of SARASOTA, Florida, that the Clerk of Court will sell the following property, in SARASOTA County, Florida, described as:

Unit 207, Building 20, VILLAGIO, a Condominium, according to the Declaration of Condominium recorded in Official Records Instrument Number 2003257048, and amendments thereto, of the Public Records of Sarasota County, Florida; together with the right of use of Carport Numbers 44 & 45, according to the Declaration of Condominium recorded in Official Records Instrument Number 2003257048, and amend-

ments thereto, of the Public Records of Sarasota County, Florida,

said property having a street address of 1005 Villaggio Circle, Bldg. # 207, Sarasota, FL 34237, at public sale, to the highest and best bidder for cash, at www.sarasota.realforeclose.com, at 9:00 A.M. on January 27, 2014. The highest bidder shall immediately post with the Clerk, a deposit equal to 5% of the final bid. The deposit must be cash or cashier's check payable to the Clerk of Court and will be applied to the sale price at the time of final payment. Final payment must be made on or before 5:00 p.m. of the day of the sale by cash or cashier's check.

Any person claiming an interest in the surplus from the sale, if any, other than the property owner as of the date of the lis pendens must file a claim within sixty (60) days after the sale.

If you are a person with a disability who needs any accommodation in order to participate in this proceeding, you are entitled, at no cost to you, to the provision of certain assistance. Please contact the Sarasota County Jury Office, P.O. Box 3079, Sarasota, Florida 34230-3079, (941)861-7400, at least seven (7) days before your scheduled court appearance, or immediately upon receiving this notification if the time before the scheduled appearance is less than seven (7) days; if you are hearing or voice impaired, call 711.

Dated this 17th day of December, 2013.

By: LEAH K. BURTON, ESQUIRE
Leah K. Burton, Esq.
The Law Offices of Kevin T. Wells, P.A.
1800 2nd Street, Suite 808
Sarasota, FL 34236
December 20, 27, 2013 13-05973S

FIRST INSERTION

NOTICE OF SALE PURSUANT TO CHAPTER 45 IN THE CIRCUIT COURT OF THE TWELFTH JUDICIAL CIRCUIT IN AND FOR SARASOTA COUNTY, FLORIDA CIVIL ACTION CASE NO.: 58-2012-CA-008372 NC DIVISION: A

BAYVIEW LOAN SERVICING, LLC, A.D., Plaintiff, vs. JOSEPH MARCINKIEWICZ A/K/A JOSEPH A. MARCINKIEWICZ, et al, Defendant(s).

NOTICE IS HEREBY GIVEN Pursuant to a Final Judgment of Foreclosure dated December 2, 2013, and entered in Case No. 58-2012-CA-008372 NC of the Circuit Court of the Twelfth Judicial Circuit in and for Sarasota County, Florida in which Bayview Loan Servicing, LLC, a D, is the Plaintiff and Joseph Marcinkewicz a/k/a Joseph A. Marcinkewicz, Rosalina Iris Sansaricq f/k/a Rosalina Marcinkewicz f/k/a Rosalina I. Marcinkewicz, Option One Mortgage Corporation, are defendants, the Sarasota County Clerk of the Circuit Court will sell to the highest and best bidder for cash in/on the Internet: www.sarasota.realforeclose.com , Sarasota County, Florida at 9:00am on the 7th day of January, 2014, the following described property as set forth in said Final Judgment of Foreclosure:

LOT 456, VENICE GARDENS, UNIT 7, AS PER PLAT THEREOF AS RECORDED IN PLAT BOOK 10, PAGE 02, OF THE PUBLIC RECORDS OF SARASOTA COUNTY, FLORIDA.

A/K/A 430-43 BRIARWOOD RD, VENICE, FL 34293

Any person claiming an interest in the surplus from the sale, if any, other than the property owner as of the date of the Lis Pendens must file a claim within 60 days after the sale.

If you are a person with a disability who needs any accommodation in order to participate in this proceeding, you are entitled, at no cost to you, to the provision of certain assistance. Please contact the Sarasota County Jury Office, P.O. Box 3079, Sarasota, Florida 34230-3079, (941)861-7400, at least seven (7) days before your scheduled court appearance, or immediately upon receiving this notification if the time before the scheduled appearance is less than seven (7) days; if you are hearing or voice impaired, call 711.

Albertelli Law Attorney for Plaintiff P.O. Box 23028 Tampa, FL 33623 (813) 221-4743 (813) 221-9171 facsimile eService: servealaw@albertellilaw.com TS - 11-82268 December 20, 27, 2013 13-05879S

FIRST INSERTION

NOTICE OF SALE PURSUANT TO CHAPTER 45 IN THE CIRCUIT COURT OF THE TWELFTH JUDICIAL CIRCUIT IN AND FOR SARASOTA COUNTY, FLORIDA CIVIL ACTION CASE NO.: 2011 CA 000752 NC WELLS FARGO BANK, N.A., Plaintiff, vs. JOSEPH F. MAIORANA, et al, Defendant(s).

NOTICE IS HEREBY GIVEN Pursuant to a Final Judgment of Foreclosure dated September 23, 2013, and entered in Case No. 2011 CA 000752 NC of the Circuit Court of the Twelfth Judicial Circuit in and for Sarasota County, Florida in which Wells Fargo Bank, N.A., is the Plaintiff and Joseph F. Maiorana, Sarasota County, Florida, Victoria Keane, Barbara J. Maiorana, Sarasota County Clerk of the Circuit Court, State of Florida, Tenant #1 n/k/a Ray Hale, are defendants, the Sarasota County Clerk of the Circuit Court will sell to the highest and best bidder for cash in/on the Internet: www.sarasota.realforeclose.com , Sarasota County, Florida at 9:00am on the 22nd day of January, 2014, the following described property as set forth in said Final Judgment of Foreclosure:

LOT 17, BLOCK 473, 8TH ADDITION TO PORT CHARLOTTE SUBDIVISION, ACCORDING TO THE PLAT THEREOF, AS RECORDED IN PLAT BOOK 12, PAGES 20A THROUGH 20Z, INCLUSIVE, OF THE PUBLIC RECORDS OF SARASOTA COUNTY, FLORIDA.

A/K/A 2323 PILGER AVE, NORTH PORT, FL 34286-6146

Any person claiming an interest in the surplus from the sale, if any, other than the property owner as of the date of the Lis Pendens must file a claim within 60 days after the sale.

If you are a person with a disability who needs any accommodation in order to participate in this proceeding, you are entitled, at no cost to you, to the provision of certain assistance. Please contact the Sarasota County Jury Office, P.O. Box 3079, Sarasota, Florida 34230-3079, (941)861-7400, at least seven (7) days before your scheduled court appearance, or immediately upon receiving this notification if the time before the scheduled appearance is less than seven (7) days; if you are hearing or voice impaired, call 711.

Albertelli Law Attorney for Plaintiff P.O. Box 23028 Tampa, FL 33623 (813) 221-4743 (813) 221-9171 facsimile eService: servealaw@albertellilaw.com BM - 10-61932 December 20, 27, 2013 13-05885S

FIRST INSERTION

NOTICE OF SALE PURSUANT TO CHAPTER 45 IN THE CIRCUIT COURT OF THE TWELFTH JUDICIAL CIRCUIT IN AND FOR SARASOTA COUNTY, FLORIDA CIVIL ACTION CASE NO.: 58-2010-CA-012744 NC DIVISION: C WELLS FARGO BANK, N.A., Plaintiff, vs. ROBERT D. KRIEG, et al, Defendant(s).

NOTICE IS HEREBY GIVEN Pursuant to a Final Judgment of Foreclosure dated September 24, 2013, and entered in Case No. 58-2010-CA-012744 NC of the Circuit Court of the Twelfth Judicial Circuit in and for Sarasota County, Florida in which Wells Fargo Bank, N.A., is the Plaintiff and Robert D. Krieg, Oak Ford Golf Club Owners Association, Inc., are defendants, the Sarasota County Clerk of the Circuit Court will sell to the highest and best bidder for cash in/on the Internet: www.sarasota.realforeclose.com , Sarasota County, Florida at 9:00am on the 22nd day of January, 2014, the following described property as set forth in said Final Judgment of Foreclosure:

LOT 98, OAK FORD GOLF CLUB SUBDIVISION, ACCORDING TO THE PLAT THEREOF RECORDED IN PLAT BOOK 34, PAGES 31, 31A THROUGH 31Y, OF THE PUBLIC RECORDS OF SARASOTA COUNTY, FLORIDA.

A/K/A 1582 OAKFORD RD., SARASOTA, FL 34240-7003

Any person claiming an interest in the surplus from the sale, if any, other than the property owner as of the date of the Lis Pendens must file a claim within 60 days after the sale.

If you are a person with a disability who needs any accommodation in order to participate in this proceeding, you are entitled, at no cost to you, to the provision of certain assistance. Please contact the Sarasota County Jury Office, P.O. Box 3079, Sarasota, Florida 34230-3079, (941)861-7400, at least seven (7) days before your scheduled court appearance, or immediately upon receiving this notification if the time before the scheduled appearance is less than seven (7) days; if you are hearing or voice impaired, call 711.

Albertelli Law Attorney for Plaintiff P.O. Box 23028 Tampa, FL 33623 (813) 221-4743 (813) 221-9171 facsimile eService: servealaw@albertellilaw.com BM - 10-56968 December 20, 27, 2013 13-05886S

FIRST INSERTION

NOTICE OF FORECLOSURE SALE IN THE CIRCUIT COURT OF THE TWELFTH JUDICIAL CIRCUIT IN AND FOR SARASOTA COUNTY, FLORIDA GENERAL JURISDICTION DIVISION CASE NO. 2012 CA 003647 NC NATIONSTAR MORTGAGE LLC., Plaintiff, vs. LOREN D. FILLER AND ROSE M. FILLER, et al, Defendant(s).

NOTICE IS HEREBY GIVEN Pursuant to a Final Judgment of Foreclosure dated DECEMBER 2, 2013, and entered in Case No. 2012 CA 003647 NC of the Circuit Court of the Twelfth Judicial Circuit in and for Sarasota County, Florida, wherein NATIONSTAR MORTGAGE LLC., is the Plaintiff and LOREN D. FILLER; ROSE M. FILLER; UNKNOWN TENANT(S) are the Defendant(s). Karen Rushing as the Clerk of the Circuit Court will sell to the highest and best bidder for cash, www.sarasota.realforeclose.com, at 09:00 AM on JANUARY 6, 2014, the following described property as set forth in said Final Judgment, to wit:

LOT 12, BLOCK 1144, 25TH ADDITION TO PORT CHARLOTTE SUBDIVISION, ACCORDING TO THE PLAT THEREOF, AS RECORDED IN PLAT BOOK 15, AT PAGES 2, 2A THROUGH 2Q OF THE PUBLIC RECORDS OF SARASOTA COUNTY, FLORIDA.

Any person claiming an interest in the surplus from the sale, if any, other than the property owner as of the date of the Lis Pendens must file a claim within 60 days after the sale.

If you are a person with a disability who needs any accommodation in order to participate in this proceeding, you are entitled, at no cost to you, to the provision of certain assistance. Please contact the Sarasota County Jury Office, P.O. Box 3079, Sarasota, Florida 34230-3079, (941)861-7400, at least seven (7) days before your scheduled court appearance, or immediately upon receiving this notification if the time before the scheduled appearance is less than seven (7) days; if you are hearing or voice impaired, call 711.

Dated this 12th day of December, 2013.

By: Liana R. hall FL Bar No. 73813 for Laura Elise Goorland Florida Bar: 55402 Robertson, Anschutz & Schneid, PL Attorneys for Plaintiff 6409 Congress Avenue, Suite 100 Boca Raton, Florida 33487 11-20908 December 20, 27, 2013 13-05925S

FIRST INSERTION

NOTICE OF SALE PURSUANT TO CHAPTER 45 IN THE CIRCUIT COURT OF THE TWELFTH JUDICIAL CIRCUIT IN AND FOR SARASOTA COUNTY, FLORIDA CIVIL ACTION CASE NO.: 2011 CA 000312 NC WELLS FARGO BANK, N.A., Plaintiff, vs. LUBOV MELNICHENKO, et al, Defendant(s).

NOTICE IS HEREBY GIVEN Pursuant to a Final Judgment of Foreclosure dated September 24, 2013, and entered in Case No. 2011 CA 000312 NC of the Circuit Court of the Twelfth Judicial Circuit in and for Sarasota County, Florida in which Wells Fargo Bank, N.A., is the Plaintiff and Lubov Melnichenko, Tenant #1 n/k/a Galina Melnichenko, are defendants, the Sarasota County Clerk of the Circuit Court will sell to the highest and best bidder for cash in/on the Internet: www.sarasota.realforeclose.com , Sarasota County, Florida at 9:00am on the 22nd day of January, 2014, the following described property as set forth in said Final Judgment of Foreclosure:

LOT 1, BLOCK 558, OF EIGHTEENTH ADDITION TO PORT CHARLOTTE SUBDIVISION, ACCORDING TO THE PLAT THEREOF, AS RECORDED IN PLAT BOOK 14, PAGES 6, 6A THROUGH 6V, OF THE PUBLIC RECORDS OF SARASOTA COUNTY, FLORIDA.

A/K/A 2652 PEAKE STREET, NORTH PORT, FL 34286

Any person claiming an interest in the surplus from the sale, if any, other than the property owner as of the date of the Lis Pendens must file a claim within 60 days after the sale.

If you are a person with a disability who needs any accommodation in order to participate in this proceeding, you are entitled, at no cost to you, to the provision of certain assistance. Please contact the Sarasota County Jury Office, P.O. Box 3079, Sarasota, Florida 34230-3079, (941)861-7400, at least seven (7) days before your scheduled court appearance, or immediately upon receiving this notification if the time before the scheduled appearance is less than seven (7) days; if you are hearing or voice impaired, call 711.

Albertelli Law Attorney for Plaintiff P.O. Box 23028 Tampa, FL 33623 (813) 221-4743 (813) 221-9171 facsimile eService: servealaw@albertellilaw.com BM-09-27808 December 20, 27, 2013 13-05884S

FIRST INSERTION

NOTICE OF SALE PURSUANT TO CHAPTER 45 IN THE CIRCUIT COURT OF THE TWELFTH JUDICIAL CIRCUIT IN AND FOR SARASOTA COUNTY, FLORIDA CIVIL ACTION CASE NO.: 2010 CA 011888 NC HSBC BANK USA, Plaintiff, vs. BEVERLY B. PAINTING, et al, Defendant(s).

NOTICE IS HEREBY GIVEN Pursuant to a Final Judgment of Foreclosure dated September 23, 2013, and entered in Case No. 2010 CA 011888 NC of the Circuit Court of the Twelfth Judicial Circuit in and for Sarasota County, Florida in which HSBC Bank USA, is the Plaintiff and Beverly B. Painting, Iberiabank, Tenant #1 n.k.a MARK HERRINGTON, are defendants, the Sarasota County Clerk of the Circuit Court will sell to the highest and best bidder for cash in/on the Internet: www.sarasota.realforeclose.com , Sarasota County, Florida at 9:00am on the 22nd day of January, 2014, the following described property as set forth in said Final Judgment of Foreclosure:

LOT 23, LOCKWOOD GARDENS SUBDIVISION ACCORDING TO THE PLAT THEREOF, AS RECORDED IN PLAT BOOK 17, AT PAGES 19, OF THE PUBLIC RECORDS SARASOTA COUNTY, FLORIDA.

A/K/A 3350 BAILEY STREET, SARASOTA, FL 34237-4712

Any person claiming an interest in the surplus from the sale, if any, other than the property owner as of the date of the Lis Pendens must file a claim within 60 days after the sale.

If you are a person with a disability who needs any accommodation in order to participate in this proceeding, you are entitled, at no cost to you, to the provision of certain assistance. Please contact the Sarasota County Jury Office, P.O. Box 3079, Sarasota, Florida 34230-3079, (941)861-7400, at least seven (7) days before your scheduled court appearance, or immediately upon receiving this notification if the time before the scheduled appearance is less than seven (7) days; if you are hearing or voice impaired, call 711.

Albertelli Law Attorney for Plaintiff P.O. Box 23028 Tampa, FL 33623 (813) 221-4743 (813) 221-9171 facsimile eService: servealaw@albertellilaw.com BM - 10-51850 December 20, 27, 2013 13-05881S

FIRST INSERTION

NOTICE OF SALE IN THE CIRCUIT COURT OF THE TWELFTH JUDICIAL CIRCUIT IN AND FOR SARASOTA COUNTY, FLORIDA CIVIL DIVISION Case #: 2011-CA-009151-NC DIVISION: A

Bank of America, National Association as Successor by Merger to BAC Home Loans Servicing, L.P. f/k/a Countrywide Home Loans Servicing, L.P. Plaintiff, -vs.- Laurie Messina; Cedar Hammock Owners' Association, Inc.; Unknown Parties in Possession #1, If living, and all Unknown Parties claiming by, through, under and against the above named Defendant(s) who are not known to be dead or alive, whether said Unknown Parties may claim an interest as Spouse, Heirs, Devisees, Grantees, or Other Claimants; Unknown Parties in Possession #2, If living, and all Unknown Parties claiming by, through, under and against the above named Defendant(s) who are not known to be dead or alive, whether said Unknown Parties may claim an interest as Spouse, Heirs, Devisees, Grantees, or Other Claimants Defendant(s).

NOTICE IS HEREBY GIVEN Pursuant to an Order dated December 2, 2013, entered in Civil Case No. 2011-CA-009151-NC of the Circuit Court of the 12th Judicial Circuit in and for Sarasota County, Florida, wherein Bank of America, National Association as Successor by Merger to BAC Home Loans Servicing, L.P. f/k/a Countrywide Home Loans Servicing, L.P., Plaintiff and Laurie Messina are defendant(s), I, Clerk of Court, Karen E. Rushing, will sell to the highest and best bidder for cash VIA THE INTERNET AT WWW.SARASOTA.REALFORECLOSE.COM , AT 9:00 A.M. on January 2, 2014, the following described property as set forth in said Final Judgment, to-wit:

THAT PART OF LOT 1, BLOCK "C", AND TRACT 1, CEDAR HAMMOCK SUBDIVISION, AS PER PLAT THEREOF, RECORDED IN PLAT BOOK 28, PAGES 21 THROUGH 21-D, OF THE PUBLIC RECORDS OF SARASOTA COUNTY, FLORIDA, BEING MORE PARTICULARLY DESCRIBED AS FOLLOWS: BEGIN AT THE NORTHWEST CORNER OF LOT 1, BLOCK C, CEDAR HAMMOCK SUBDIVISION, AS PER PLAT THEREOF, RECORDED IN PLAT BOOK 28, PAGES 21 THROUGH 21-D, OF THE PUBLIC RECORDS OF SARASOTA COUNTY, FLORIDA, THENCE SOUTH 05°18'31" WEST, A DISTANCE OF 81.73 FEET; THENCE SOUTH 68°27'07" EAST, 109.99 FEET; THENCE NORTH 50°17'52" EAST, 12.59 FEET; THENCE NORTH 31°49'48" WEST, 130.39 FEET; THENCE SOUTHWESTERLY, ALONG A CURVE WHOSE RADIUS IS 50.00 FEET, AND WHOSE RADIUS POINT BEARS NORTH 16°12'17" WEST, FROM SAID POINT, SAID CURVE HAVING A CENTRAL ANGLE OF 41°55'02", AND AN ARC DISTANCE OF 36.59 FEET, TO THE POINT OF BEGINNING.

ANY PERSON CLAIMING AN INTEREST IN THE SURPLUS FROM THE SALE, IF ANY, OTHER THAN THE PROPERTY OWNER AS OF THE DATE OF THE LIS PENDENS MUST FILE A CLAIM WITHIN 60 DAYS AFTER THE SALE.

If you are a person with a disability who needs any accommodation in order to participate in this proceeding, you are entitled, at no cost to you, to the provision of certain assistance. Please contact the Sarasota County Jury Office, P.O. Box 3079, Sarasota, Florida 34230-3079, (941)861-7400, at least seven (7) days before your scheduled court appearance, or immediately upon receiving this notification if the time before the scheduled appearance is less than seven (7) days; if you are hearing or voice impaired, call 711.

Submitted By: ATTORNEY FOR PLAINTIFF: SHAPIRO, FISHMAN & GACHE, LLP 2424 North Federal Highway, Suite 360 Boca Raton, Florida 33431 (561) 998-6700 (561) 998-6707 10-192887 FC01 CWF December 20, 27, 2013 13-05903S

FIRST INSERTION

NOTICE OF SALE PURSUANT TO CHAPTER 45 IN THE CIRCUIT COURT OF THE TWELFTH JUDICIAL CIRCUIT IN AND FOR SARASOTA COUNTY, FLORIDA CIVIL ACTION CASE NO.: 2011 CA 001013 NC DIVISION: A

DEUTSCHE BANK NATIONAL TRUST COMPANY, AS TRUSTEE OF THE INDYMAC INDX MORTGAGE TRUST 2006-AR4, MORTGAGE PASS-THROUGH CERTIFICATES, SERIES 2006-AR4 UNDER THE POOLING AND SERVICING AGREEMENT DATED MARCH 1, 2006, Plaintiff, vs. JEFFREY G. GREENWALD, et al, Defendant(s).

NOTICE IS HEREBY GIVEN Pursuant to a Final Judgment of Foreclosure dated September 24, 2013, and entered in Case No. 2011 CA 001013 NC of the Circuit Court of the Twelfth Judicial Circuit in and for Sarasota County, Florida in which Deutsche Bank National Trust Company, as Trustee of the IndyMac INDX Mortgage Trust 2006-AR4, Mortgage Pass-Through Certificates, Series 2006-AR4 under the Pooling and Servicing Agreement dated March 1, 2006, is the Plaintiff and Jeffrey G. Greenwald, Mortgage Electronic Registration Systems, Inc., as nominee for Mortgageit, Inc., The Unknown Spouse of Jeffrey Greenwald n/k/a Aida Greenwald, Amy E. Greenwald, Rommy Rodas, Any And All Unknown Parties Claiming by, Through, Under, And Against The Herein named Individual Defendant(s) Who are not Known To Be Dead Or Alive, Whether Said Unknown Parties May Claim An Interest in Spouses, Heirs, Devisees, Grantees, Or Other Claimants are de-

pendants, the Sarasota County Clerk of the Circuit Court will sell to the highest and best bidder for cash in/on the Internet: www.sarasota.realforeclose.com , Sarasota County, Florida at 9:00am on the 22nd day of January, 2014, the following described property as set forth in said Final Judgment of Foreclosure:

LOTS 17276, 17277 AND 17278, SOUTH VENICE, UNIT NO. 65, AS PER PLAT THEREOF RECORDED IN PLAT BOOK 7, PAGE 44, OF THE PUBLIC RECORDS OF SARASOTA COUNTY, FLORIDA.

A/K/A 1271 ROSEDALE ROAD, VENICE, FL 34293

Any person claiming an interest in the surplus from the sale, if any, other than the property owner as of the date of the Lis Pendens must file a claim within 60 days after the sale.

If you are a person with a disability who needs any accommodation in order to participate in this proceeding, you are entitled, at no cost to you, to the provision of certain assistance. Please contact the Sarasota County Jury Office, P.O. Box 3079, Sarasota, Florida 34230-3079, (941)861-7400, at least seven (7) days before your scheduled court appearance, or immediately upon receiving this notification if the time before the scheduled appearance is less than seven (7) days; if you are hearing or voice impaired, call 711.

Albertelli Law Attorney for Plaintiff P.O. Box 23028 Tampa, FL 33623 (813) 221-4743 (813) 221-9171 facsimile eService: servealaw@albertellilaw.com BM-10-33771 December 20, 27, 2013 13-05880S

FIRST INSERTION

NOTICE OF FORECLOSURE SALE IN THE CIRCUIT COURT OF THE 12TH JUDICIAL CIRCUIT, IN AND FOR SARASOTA COUNTY, FLORIDA CIVIL DIVISION:

CASE NO.: 2012 CA 001639 NC DEUTSCHE BANK NATIONAL TRUST COMPANY, AS TRUSTEE FOR MORGAN STANLEY CAPITAL I INC. TRUST 2006-HE2, Plaintiff, vs. EMILY DEEBES; HIDDEN LAKE VILLAGE OF SARASOTA, INC.; MORTGAGE ELECTRONIC REGISTRATION SYSTEMS, INCORPORATED, AS NOMINEE FOR WMC MORTGAGE CORP.; UNKNOWN SPOUSE OF EMILY DEEBES; UNKNOWN TENANT IN POSSESSION OF THE SUBJECT PROPERTY, Defendants.

NOTICE IS HEREBY GIVEN Pursuant to Final Judgment of Foreclosure dated the 2nd day of December, 2013, and entered in Case No. 2012 CA 001639 NC, of the Circuit Court of the 12TH Judicial Circuit in and for Sarasota County, Florida, wherein DEUTSCHE BANK NATIONAL TRUST COMPANY, AS TRUSTEE FOR MORGAN STANLEY CAPITAL I INC. TRUST 2006-HE2 is the Plaintiff and EMILY DEEBES; HIDDEN LAKE VILLAGE OF SARASOTA, INC.; MORTGAGE ELECTRONIC REGISTRATION SYSTEMS, INCORPORATED, AS NOMINEE FOR WMC MORTGAGE CORP.; UNKNOWN SPOUSE OF EMILY DEEBES; UNKNOWN TENANT IN POSSESSION OF THE SUBJECT PROPERTY are defendants. The Clerk of this Court shall sell to the highest and best bidder for cash electronically at www.sarasota.realforeclose.com at 9:00 AM on the 7th day of January, 2014, the following described property as set forth in said Final Judgment, to wit:

UNIT 2629-D, HIDDEN LAKE VILLAGE, A CONDOMINIUM ACCORDING TO THE DECLARATION OF CONDOMINIUM RECORDED IN OFFICIAL RECORDS BOOK 1368, PAGE 1482, AS AMENDED, AND AS PER PLAT THEREOF RECORDED IN CONDOMINIUM BOOK 14, PAGES 16, 16A THROUGH 16H, PUBLIC RECORDS OF SARASOTA COUNTY, FLORIDA.

ANY PERSON CLAIMING AN INTEREST IN THE SURPLUS FROM THE SALE, IF ANY, OTHER THAN THE PROPERTY OWNER AS OF THE DATE OF THE LIS PENDENS MUST FILE A CLAIM WITHIN 60 DAYS AFTER THE SALE.

If you are a person with a disability who needs any accommodation in order to participate in this proceeding, you are entitled, at no cost to you, to the provision of certain assistance. Please contact the Sarasota County Jury Office, P.O. Box 3079, Sarasota, Florida 34230-3079, (941)861-7400, at least seven (7) days before your scheduled court appearance, or immediately upon receiving this notification if the time before the scheduled appearance is less than seven (7) days; if you are hearing or voice impaired, call 711.

Dated this 13 day of December, 2013. By: Bruce K. Fay Bar #97308

Choice Legal Group, P.A. 1800 NW 49th Street, Suite 120 Fort Lauderdale, Florida 33309 Telephone: (954) 453-0365 Facsimile: (954) 771-6052 Toll Free: 1-800-441-2438 DESIGNATED PRIMARY E-MAIL FOR SERVICE PURSUANT TO FLA R. JUD. ADMIN 2.516 eservice@clelegalgroup.com 11-16124 December 20, 27, 2013 13-05937S

HOW TO PUBLISH YOUR LEGAL NOTICE IN THE BUSINESS OBSERVER

FOR MORE INFORMATION, CALL:
 (813) 221-9505 Hillsborough, Pasco
 (727) 447-7784 Pinellas
 (941) 906-9386 Manatee, Sarasota, Lee
 Or e-mail: legal@businessobserverfl.com
 (239) 263-0122 Collier
 (407) 654-5500 Orange
 (941) 249-4900 Charlotte

FIRST INSERTION

NOTICE OF FORECLOSURE SALE IN THE CIRCUIT COURT OF THE 12TH JUDICIAL CIRCUIT, IN AND FOR SARASOTA COUNTY, FLORIDA

CIVIL DIVISION:
CASE NO.: 2012 CA 005246 NC
WELLS FARGO FINANCIAL SYSTEM FLORIDA, INC., PLAINTIFF, VS.
TRANCLE BYRD; WELLS FARGO BANK, NA; PLESSIE M. BYRD; UNKNOWN TENANT IN POSSESSION OF THE SUBJECT PROPERTY, DEFENDANTS.

NOTICE IS HEREBY GIVEN pursuant to Final Judgment of Foreclosure dated the 2nd day of December, 2013, and entered in Case No. 2012 CA 005246 NC, of the Circuit Court of the 12TH Judicial Circuit in and for Sarasota County, Florida, wherein WELLS FARGO FINANCIAL SYSTEM FLORIDA, INC. is the Plaintiff and WELLS FARGO BANK, NA; PLESSIE M. BYRD and UNKNOWN TENANT(S) IN POSSESSION OF THE SUBJECT PROPERTY are defendants. The Clerk of this Court shall sell to the highest and best bidder for cash electronically at www.sarasota.realforeclose.com at 9:00 AM on the 7th day of January, 2014, the following described property as set forth in said Final Judgment, to wit:

LOT 2, NEW LEISURE LAKES, UNIT NO. 1, ACCORDING TO THE PLAT THEREOF RECORDED IN PLAT BOOK 11, PAGE 8, PUBLIC RECORDS OF SARASOTA COUNTY, FLORIDA
ANY PERSON CLAIMING AN INTEREST IN THE SURPLUS FROM THE SALE, IF ANY, OTHER THAN THE PROPERTY OWNER AS OF THE DATE OF THE LIS PENDENS MUST FILE A CLAIM WITHIN 60 DAYS AFTER THE SALE.

If you are a person with a disability who needs any accommodation in order to participate in this proceeding, you are entitled, at no cost to you, to the provision of certain assistance. Please contact the Sarasota County Jury Office, P.O. Box 3079, Sarasota, Florida 34230-3079, (941)861-7400, at least seven (7) days before your scheduled court appearance, or immediately upon receiving this notification if the time before the scheduled appearance is less than seven (7) days; if you are hearing or voice impaired, call 711.

Dated this 13 day of December, 2013.
By: Bruce K. Fay
Bar #97308

Choice Legal Group, P.A.
1800 NW 49th Street, Suite 120
Fort Lauderdale, Florida 33309
Telephone: (954) 453-0365
Facsimile: (954) 771-6052
Toll Free: 1-800-441-2438
DESIGNATED PRIMARY E-MAIL FOR SERVICE PURSUANT TO FLA R. JUD. ADMIN 2.516
eservice@clegalgroup.com
11-16809
December 20, 27, 2013 13-05940S

FIRST INSERTION

NOTICE OF FORECLOSURE SALE IN THE CIRCUIT COURT OF THE 12TH JUDICIAL CIRCUIT, IN AND FOR SARASOTA COUNTY, FLORIDA

CIVIL DIVISION:
CASE NO.: 2012 CA 010480 NC
FEDERAL NATIONAL MORTGAGE ASSOCIATION, Plaintiff, vs.
MELISSA REPRESS WILEY; UNKNOWN SPOUSE OF MELISSA REPRESS WILEY; UNKNOWN TENANT IN POSSESSION OF THE SUBJECT PROPERTY, Defendants.

NOTICE IS HEREBY GIVEN pursuant to Final Judgment of Foreclosure dated the 2nd day of December, 2013, and entered in Case No. 2012 CA 010480 NC, of the Circuit Court of the 12TH Judicial Circuit in and for Sarasota County, Florida, wherein FEDERAL NATIONAL MORTGAGE ASSOCIATION is the Plaintiff and MELISSA REPRESS WILEY and UNKNOWN TENANT(S) IN POSSESSION OF THE SUBJECT PROPERTY are defendants. The Clerk of this Court shall sell to the highest and best bidder for cash electronically at www.sarasota.realforeclose.com at 9:00 AM on the 8th day of January, 2014, the following described property as set forth in said Final Judgment, to wit:

LOT 1597, LAKE SARASOTA, UNIT NO. 17 AS PER PLAT THEREOF RECORDED IN PLAT BOOK 9, PAGE 23, OF THE PUBLIC RECORDS OF SARASOTA COUNTY, FLORIDA
ANY PERSON CLAIMING AN INTEREST IN THE SURPLUS FROM THE SALE, IF ANY, OTHER THAN THE PROPERTY OWNER AS OF THE DATE OF THE LIS PENDENS MUST FILE A CLAIM WITHIN 60 DAYS AFTER THE SALE.

If you are a person with a disability who needs any accommodation in order to participate in this proceeding, you are entitled, at no cost to you, to the provision of certain assistance. Please contact the Sarasota County Jury Office, P.O. Box 3079, Sarasota, Florida 34230-3079, (941)861-7400, at least seven (7) days before your scheduled court appearance, or immediately upon receiving this notification if the time before the scheduled appearance is less than seven (7) days; if you are hearing or voice impaired, call 711.

Dated this 12 day of December, 2013.
By: Bruce K. Fay
Bar #97308

Submitted by:
Choice Legal Group, P.A.
1800 NW 49th Street, Suite 120
Fort Lauderdale, Florida 33309
Telephone: (954) 453-0365
Facsimile: (954) 771-6052
Toll Free: 1-800-441-2438
DESIGNATED PRIMARY E-MAIL FOR SERVICE PURSUANT TO FLA R. JUD. ADMIN 2.516
eservice@clegalgroup.com
12-16016
December 20, 27, 2013 13-05917S

FIRST INSERTION

NOTICE OF FORECLOSURE SALE IN THE CIRCUIT COURT OF THE TWELFTH JUDICIAL CIRCUIT, IN AND FOR SARASOTA COUNTY, FLORIDA

CASE NO: 2011-CA-004610 NC
AURORA LOAN SERVICES, LLC Plaintiff, v.
JAMES BROWNING; TUESDAY BROWNING; SARASOTA COUNTY PUBLIC HOSPITAL BOARD; CITY OF NORTH PORT FLORIDA; MORTGAGE ELECTRONIC REGISTRATION SYSTEMS AS NOMINEE FOR IRWIN MORTGAGE CORPORATION; UNKNOWN TENANT, Defendants.

NOTICE IS hereby given that the undersigned, Karen E. Rushing, Clerk of the Circuit Court of Sarasota County, Florida, will on the 13th day of January, 2014, at 9:00 A.M., EST, on line at www.sarasota.realforeclose.com, in accordance with Chapter 45, F.S., offer for sale and sell at public outcry to the highest and best bidder for cash, the following described property situated in Sarasota County, Florida, to wit:

LOT 10, BLOCK 1250, TWENTY-SEVENTH ADDITION TO PORT CHARLOTTE SUBDIVISION, ACCORDING TO THE PLAT THEREOF AS RECORDED IN PLAT BOOK 15, PAGE(S) 11, 11A THRU 11M, OF THE PUBLIC RECORDS OF SARASOTA COUNTY, FLORIDA
PROPERTY ADDRESS: 4104 POMEROY STREET, NORTH PORT, FL 34286

pursuant to the Consent Final Judgment of Mortgage Foreclosure entered in a case pending in said Court, the style and case number of which is set forth above.

Any person claiming an interest in the surplus from the sale, if any, other than the property owner as of the date of the Lis Pendens must file a claim within 60 days after the sale.

If you are a person with a disability who needs any accommodation in order to participate in this proceeding, you are entitled, at no cost to you, to the provision of certain assistance. Please contact the Sarasota County Jury Office, P.O. Box 3079, Sarasota, Florida 34230-3079, (941)861-7400, at least seven (7) days before your scheduled court appearance, or immediately upon receiving this notification if the time before the scheduled appearance is less than seven (7) days; if you are hearing or voice impaired, call 711.

Submitted by:
SARASOTA COUNTY JURY OFFICE
1115 East Gonzalez Street
Pensacola, FL 32503
Telephone: (850) 462-1500
Facsimile: (850) 462-1599
December 20, 27, 2013 13-05996S

SUBMITTED on this 17th day of December, 2013.

SIROTE & PERMUTT, P.C.
Kathryn L. Kasper, Esq.
FL Bar #621188
Attorney for Plaintiff
Sirote & Permutt, P.C.
1115 East Gonzalez Street
Pensacola, FL 32503
Telephone: (850) 462-1500
Facsimile: (850) 462-1599
December 20, 27, 2013 13-05996S

FIRST INSERTION

NOTICE OF FORECLOSURE SALE IN THE CIRCUIT COURT OF THE 12TH JUDICIAL CIRCUIT, IN AND FOR SARASOTA COUNTY, FLORIDA

CIVIL DIVISION:
CASE NO.: 2008 CA 015213 SC
AURORA LOAN SERVICES, LLC, Plaintiff, vs.
AHMED A. ZAPATA; MARINA E. RODRIGUEZ; JOHN DOE; JANE DOE UNKNOWN TENANT(S) IN POSSESSION OF THE SUBJECT PROPERTY, Defendants.

NOTICE IS HEREBY GIVEN pursuant to an Order Resetting Foreclosure Sale dated the 10th day of December, 2013, and entered in Case No. 2008 CA 015213 SC, of the Circuit Court of the 12TH Judicial Circuit in and for Sarasota County, Florida, wherein NATIONSTAR MORTGAGE LLC is the Plaintiff and AHMED A. ZAPATA; MARINA E. RODRIGUEZ and UNKNOWN TENANT(S) IN POSSESSION OF THE SUBJECT PROPERTY are defendants. The Clerk of this Court shall sell to the highest and best bidder for cash electronically at www.sarasota.realforeclose.com at 9:00 AM on the 14th day of January, 2014, the following described property as set forth in said Final Judgment, to wit:

LOT 25, BLOCK 541, 18TH ADDITION TO PORT CHARLOTTE SUBDIVISION, ACCORDING TO THE PLAT THEREOF, AS RECORDED IN PLAT BOOK 14, AT PAGES, 6, 6A THROUGH 6V, OF THE PUBLIC RECORDS OF SARASOTA COUNTY, FLORIDA.

ANY PERSON CLAIMING AN INTEREST IN THE SURPLUS FROM THE SALE, IF ANY, OTHER THAN THE PROPERTY OWNER AS OF THE DATE OF THE LIS PENDENS MUST FILE A CLAIM WITHIN 60 DAYS AFTER THE SALE.

If you are a person with a disability who needs any accommodation in order to participate in this proceeding, you are entitled, at no cost to you, to the provision of certain assistance. Please contact the Sarasota County Jury Office, P.O. Box 3079, Sarasota, Florida 34230-3079, (941)861-7400, at least seven (7) days before your scheduled court appearance, or immediately upon receiving this notification if the time before the scheduled appearance is less than seven (7) days; if you are hearing or voice impaired, call 711.

Dated this 17th day of December, 2013.

Submitted by:
Carri L. Pereyra
Bar #17441
Choice Legal Group, P.A.
1800 NW 49th Street, Suite 120
Fort Lauderdale, Florida 33309
Telephone: (954) 453-0365
Facsimile: (954) 771-6052
Toll Free: 1-800-441-2438
DESIGNATED PRIMARY E-MAIL FOR SERVICE PURSUANT TO FLA R. JUD. ADMIN 2.516
eservice@clegalgroup.com
08-39210
December 20, 27, 2013 13-06001S

FIRST INSERTION

NOTICE OF SALE PURSUANT TO CHAPTER 45 IN THE CIRCUIT COURT OF THE TWELFTH JUDICIAL CIRCUIT IN AND FOR SARASOTA COUNTY, FLORIDA

CIVIL ACTION
CASE NO.: 2011 CA 004013 NC
DIVISION: C
DEUTSCHE BANK NATIONAL TRUST COMPANY, AS TRUSTEE OF THE INDYMAC INDEX MORTGAGE LOAN TRUST 2004-AR5, MORTGAGE PASS-THROUGH CERTIFICATES, SERIES 2004-AR5 UNDER THE POOLING AND SERVICING AGREEMENT DATED AUGUST 1, 2004, Plaintiff, vs.

INGRID WEND, et al, Defendant(s).
NOTICE IS HEREBY GIVEN Pursuant to a Final Judgment of Foreclosure dated October 15, 2013, and entered in Case No. 2011 CA 004013 NC of the Circuit Court of the Twelfth Judicial Circuit in and for Sarasota County, Florida in which Deutsche Bank National Trust Company, as Trustee of the IndyMac INDX Mortgage Loan Trust 2004-AR5, Mortgage Pass-Through Certificates, Series 2004-AR5 under the Pooling and Servicing Agreement dated August 1, 2004, is the Plaintiff and Ingrid Wend, OneWest Bank, FSB, successor in interest to, IndyMac Bank, FSB, are defendants, the Sarasota County Clerk of the Circuit Court will sell to the highest and best bidder for cash in/on the Internet: www.sarasota.realforeclose.com, Sarasota County, Florida at 9:00am on the 24th day of January, 2014, the following described property as set forth in said Final Judgment of Foreclosure:

LOT 1, BLOCK 117, 8TH ADDITION TO PORT CHARLOTTE SUBDIVISION, A SUBDIVISION ACCORDING TO THE PLAT THEREOF AS RECORDED IN PLAT BOOK 12, PAGES 20, 20A-20Z2, OF THE PUBLIC RECORDS OF SARASOTA COUNTY, FLORIDA.

A/K/A 3106 MAYFLOWER TER., NORTH PORT, FL 34286-7594
Any person claiming an interest in the surplus from the sale, if any, other than the property owner as of the date of the Lis Pendens must file a claim within 60 days after the sale.

If you are a person with a disability who needs any accommodation in order to participate in this proceeding, you are entitled, at no cost to you, to the provision of certain assistance. Please contact the Sarasota County Jury Office, P.O. Box 3079, Sarasota, Florida 34230-3079, (941)861-7400, at least seven (7) days before your scheduled court appearance, or immediately upon receiving this notification if the time before the scheduled appearance is less than seven (7) days; if you are hearing or voice impaired, call 711.

Dated this 13 day of December, 2013.
By: Bruce K. Fay
Bar #97308
Choice Legal Group, P.A.
1800 NW 49th Street, Suite 120
Fort Lauderdale, Florida 33309
Telephone: (954) 453-0365
Facsimile: (954) 771-6052
Toll Free: 1-800-441-2438
DESIGNATED PRIMARY E-MAIL FOR SERVICE PURSUANT TO FLA R. JUD. ADMIN 2.516
eservice@clegalgroup.com
09-29003
December 20, 27, 2013 13-05966S

FIRST INSERTION

ADVERTISEMENT OF SALE

NOTICE IS HEREBY GIVEN THAT BUDGET SELF STORAGE INTENDS TO SELL THE PERSONAL PROPERTY DESCRIBED BELOW TO ENFORCE A LIEN IMPOSED ON SAID PROPERTY UNDER THE FLORIDA SELF STORAGE FACILITY ACT STATUTES (SECTION 83.801-83.809). THE OWNER WILL SELL AT PUBLIC SALE ON WEDNESDAY, THE 8TH OF JANUARY 8TH 2014, AT THE LOCATIONS AND TIMES INDICATED BELOW.

BUDGET SELF STORAGE

5425 N. Washington Blvd Sarasota, FL 34234 @ ...2.00PM. THE FOLLOWING:

NAME	UNIT#	ITEMS STORED
Gary Thorton	A02 & E45E46	Restaurant Equipment
Denesa Ford-Edwards	B11	Household Goods
Rosalind L Mccloud	B17 & G21	Household Items
Robert D Blankenship	C10	Furniture/Boxes
Sierra Cunningham	c19	Household Items
Joseph B Smith	c31	Furniture/Boxes
Evette Carter	D26	Personal Items
Crina White	D30	Household Items
Michael Peterson	E25	Household Items
Vivian Robinson	E34	Household Items
Mamie Lawson	E41	HHG
Kenneth L Edmondson	F01	Personal
Jack L Vanlent	F13	Household Misc
Desiree Mitchell	F18	Household Goods
Terrence Jefferson	F38	Household Items
F.S. McPhail	G26	Household Goods
Shateera R Wyche	G48	Furniture/household misc
Taqisha Jackson	H07	Furniture/Household Clothing/Toys
Christopher Young	1012	Furniture/household items
Krista Bowley	1082	Furniture/household items
Lucretia Clark	1121	Household Goods
Harry V Walters	1240	Household Goods
Carmen Colon Rivera	1236	Beds bikes household items
Jocquitta T Williams	1246	Furniture/Pictures
Robert S Lee	L09	Misc Items
Cody Costello	CC04	Household Goods
Teddy Foster	B01	Clothing/Boxes
Marc Lafferty	XX04	Household Items
Jacqueline Hill	XX40	Household Items

4029 Bee Ridge Rd., Sarasota, FL. 34233... @ 4:00 PM. THE FOLLOWING:

NAME	UNIT#	ITEMS STORED
Rachel Padro	122	HHG
Chris Orr	508	HHG
Devon Johnson	606	business inv
Don Crebo	631/711	business needs/business
Mark Brown	636	household
Madeline Gove	651	household
Gregory Braun	655	HHG
Nicholas Pirchio	677	household
James Achille	816	HOUSEHOLD
Jennifer Peterson	1107	HHG

SALE SUBJECT TO CANCELLATION IN THE EVENT OF SETTLEMENT. SHOULD IT BE IMPOSSIBLE TO DISPOSE OF THESE GOODS ON THE DAY OF SALE, THE SALE WILL BE CONTINUED ON SUCH SUCCEEDING DAYS THEREAFTER AS MAY BE NECESSARY TO COMPLETE THE SALE.

December 20, 27, 2013 13-05949S

FIRST INSERTION

NOTICE OF FORECLOSURE SALE IN THE CIRCUIT COURT OF THE 12TH JUDICIAL CIRCUIT, IN AND FOR SARASOTA COUNTY, FLORIDA

CIVIL DIVISION
CASE NO. 58-2009 CA 021185 NC
FANNIE MAE ("FEDERAL NATIONAL MORTGAGE ASSOCIATION") Plaintiff, vs.

JOHN MUNSHOWER A/K/A JOHN G. MUNSHOWER; et al; Defendants.

NOTICE IS HEREBY GIVEN pursuant to a Final Judgment of Foreclosure dated December 3, 2013, and entered in Case No. 58-2009 CA 021185 NC, of the Circuit Court of the 12th Judicial Circuit in and for SARASOTA County, Florida. FANNIE MAE ("FEDERAL NATIONAL MORTGAGE ASSOCIATION") is Plaintiff and JOHN MUNSHOWER A/K/A JOHN G. MUNSHOWER; UNKNOWN SPOUSE OF JOHN MUNSHOWER A/K/A JOHN G. MUNSHOWER IF ANY; ANY AND ALL UNKNOWN PARTIES CLAIMING BY, THROUGH, UNDER, AND AGAINST THE HEREIN NAMED INDIVIDUAL DEFENDANT(S) WHO ARE NOT KNOWN TO BE DEAD OR ALIVE, WHETHER SAID UNKNOWN PARTIES MAY CLAIM AN INTEREST AS SPOUSES, HEIRS, DEVISEES, GRANTEEES OR OTHER CLAIMANTS; JOHN DOE; AND JANE DOE AS UNKNOWN TENANTS IN POSSESSION; LAYTON ENTERPRISES, LLC; HIDDEN LAKE VILLAGE OF SARASOTA, INC.; are defendants. The Clerk of Court will sell to the highest and best bidder for cash by electronic sale at: www.sarasota.realforeclose.com, at 9:00 A.M., on the 13th day of January, 2014, the following described property as set forth in said Final Judgment, to wit:

UNIT NO. 2616A, HIDDEN LAKE VILLAGE, A CONDOMINIUM, AND AN UNDIVIDED 1/254 INTEREST IN THE LAND, COMMON ELEMENTS AND COMMON EXPENSES

APPURTENANT TO SAID UNIT, ALL IN ACCORDANCE WITH AN SUBJECT TO THE COVENANTS, CONDITIONS, RESTRICTIONS, TERMS AND OTHER PROVISIONS OF THAT DECLARATION OF CONDOMINIUM OF HIDDEN LAKE VILLAGE, A CONDOMINIUM, AS RECORDED IN O.R. BOOK 1368, PAGES 1482 THROUGH 1546, INCLUSIVE, AND AS SHOWN BY PLOT PLANS OF THE CONDOMINIUM RECORDED IN CONDOMINIUM BOOK 14, PAGES 16 THROUGH 16 H, INCLUSIVE, ALL OF THE PUBLIC RECORDS OF SARASOTA COUNTY, FLORIDA.

A person claiming an interest in the surplus from the sale, if any, other than the property owner as of the date of the lis pendens must file a claim within 60 days after the sale.

If you are a person with a disability who needs any accommodation in order to participate in this proceeding, you are entitled, at no cost to you, to the provision of certain assistance. Please contact the Sarasota County Jury Office, P.O. Box 3079, Sarasota, Florida 34230-3079, (941)861-7400, at least seven (7) days before your scheduled court appearance, or immediately upon receiving this notification if the time before the scheduled appearance is less than seven (7) days; if you are hearing or voice impaired, call 711.

Dated this 16th day of December, 2013.

Submitted by:
Stacy D. Robins, Esq.
Bar No.: 008079
Kahane & Associates, P.A.
8201 Peters Road,
Ste.3000
Plantation, FL 33324
Telephone: (954) 382-3486
Telefacsimile: (954) 382-5380
Designated service email:
notice@kahaneandassociates.com
File No.: 10-18980 LBPS
December 20, 27, 2013 13-05970S

FIRST INSERTION

RE-NOTICE OF FORECLOSURE SALE IN THE CIRCUIT COURT OF THE 12TH JUDICIAL CIRCUIT, IN AND FOR SARASOTA COUNTY, FLORIDA

CIVIL DIVISION:
CASE NO.: 2009 CA 008496 NC
SUNTRUST MORTGAGE, INC., Plaintiff, vs.
ROBERT M. LONG, JR AKA ROBERT LONG; BRIAN T. MCGLOONE A/K/A BRIAN MCGLOONE A/K/A BRIAN T. MC GLOONE A/K/A BRIAN MC GLOONE; UNKNOWN TENANT(S); IN POSSESSION OF THE SUBJECT PROPERTY, Defendants.

NOTICE IS HEREBY GIVEN pursuant to an Order Resetting Foreclosure Sale dated the 5th day of December, 2013, and entered in Case No. 2009 CA 008496 NC, of the Circuit Court of the 12TH Judicial Circuit in and for Sarasota County, Florida, wherein NATIONSTAR MORTGAGE, LLC is the Plaintiff and ROBERT M. LONG, JR AKA ROBERT LONG; BRIAN T. MCGLOONE A/K/A BRIAN MCGLOONE A/K/A BRIAN T. MC GLOONE A/K/A BRIAN MC GLOONE; UNKNOWN TENANT(S); IN POSSESSION OF THE SUBJECT PROPERTY are defendants. The Clerk of this Court shall sell to the highest and best bidder for cash electronically at www.sarasota.realforeclose.com at 9:00 AM on the 10th day of January, 2014, the following described property as set forth in said Final Judgment, to wit:

LOT 24, BLOCK 176, SECOND ADDITION TO PORT CHARLOTTE SUBDIVISION, ACCORDING TO THE PLAT THEREOF RECORDED IN PLAT BOOK 11, PAGES 30, 30A THRU 30G, OF THE PUBLIC RECORDS OF SARASOTA COUNTY, FLORIDA.

ANY PERSON CLAIMING AN INTEREST IN THE SURPLUS FROM THE SALE, IF ANY, OTHER THAN THE PROPERTY OWNER AS OF THE DATE OF THE LIS PENDENS MUST FILE A CLAIM WITHIN 60 DAYS AFTER THE SALE.

If you are a person with a disability who needs any accommodation in order to participate in this proceeding, you are entitled, at no cost to you, to the provision of certain assistance. Please contact the Sarasota County Jury Office, P.O. Box 3079, Sarasota, Florida 34230-3079, (941)861-7400, at least seven (7) days before your scheduled court appearance, or immediately upon receiving this notification if the time before the scheduled appearance is less than seven (7) days; if you are hearing or voice impaired, call 711.

Dated this 13 day of December, 2013.
By: Bruce K. Fay
Bar #97308

Choice Legal Group, P.A.
1800 NW 49th Street, Suite 120
Fort Lauderdale, Florida 33309
Telephone: (954) 453-0365
Facsimile: (954) 771-6052
Toll Free: 1-800-441-2438
DESIGNATED PRIMARY E-MAIL FOR SERVICE PURSUANT TO FLA R. JUD. ADMIN 2.516
eservice@clegalgroup.com
09-29003
December 20, 27, 2013 13-05939S

FIRST INSERTION

NOTICE OF SALE IN THE CIRCUIT COURT OF THE TWELFTH JUDICIAL CIRCUIT, IN AND FOR SARASOTA COUNTY, FLORIDA

CASE NO. 2010 CA 005905 NC
WELLS FARGO BANK, N.A. AS TRUSTEE OF WAMU MORTGAGE PASS-THROUGH CERTIFICATES, SERIES 2005-PR4 TRUST; Plaintiff, vs.
THERESA F. DAVIS A/K/A THERESA F. NEVIS; DONALD L. NEVIS, SR.; ET AL; Defendants

NOTICE IS HEREBY GIVEN that, in accordance with the Final Judgment of Foreclosure dated December 2, 2013 entered in Civil Case No. 2010 CA 005905 NC of the Circuit Court of the TWELFTH Judicial Circuit in and for Sarasota County, Florida, wherein WELLS FARGO BANK, N.A. AS TRUSTEE OF WAMU MORTGAGE PASS-THROUGH CERTIFICATES, SERIES 2005-PR4 TRUST, Plaintiff and THERESA F. NEVIS A/K/A THERESA F. NEVIS A/K/A THERESA F. DAVIS, Et Al; are defendant(s). The Clerk will sell to the highest and best bidder for cash, AT www.sarasota.realforeclose.com IN ACCORDANCE WITH CHAPTER 45, FLORIDA STATUTES, AT 9:00 AM, January 6, 2014 the following described property as set forth in said Final Judgment, to-wit:

LOT 3, BLOCK 1474, 30th ADDITION TO PORT CHARLOTTE SUBDIVISION, ACCORDING TO THE PLAT THEREOF, AS RECORDED IN PLAT BOOK 15, PAGE(S) 14, 14A

THROUGH 14Q, INCLUSIVE, OF THE PUBLIC RECORDS OF SARASOTA COUNTY, FLORIDA.

Property Address: 6261 KEATING AVE., NORTH PORT, FL 34286

ANY PERSON CLAIMING AN INTEREST IN THE SURPLUS FROM THE SALE, IF ANY, OTHER THAN THE PROPERTY OWNER AS OF THE DATE OF THE LIS PENDENS MUST FILE A CLAIM WITHIN 60 DAYS AFTER THE SALE.

If you are a person with a disability who needs any accommodation in order to participate in this proceeding, you are entitled, at no cost to you, to the provision of certain assistance. Please contact the Sarasota County Jury Office, P.O. Box 3079, Sarasota, Florida 34230-3079, (941)861-7400, at least seven (7) days before your scheduled court appearance, or immediately upon receiving this notification if the time before the scheduled appearance is less than seven (7) days; if you are hearing or voice impaired, call 711.

DATED this 13 day of December, 2013.

Submitted by:
Dionne McFarlane-Douglas, Esq.
FBN 90480
Attorneys for Plaintiff
Marinosi Law Group, P.C.
100 West Cypress Creek Road,
Suite 1045
Fort Lauderdale, FL 33309
Phone: (954)-644-8704;
Fax (954) 772-9601
ServiceFL@mlg-defaultlaw.com
ServiceFL2@mlg-defaultlaw.com
11-05417
December 20, 27, 2013 13-05944S

FIRST INSERTION

NOTICE OF FORECLOSURE SALE IN THE CIRCUIT COURT OF THE 12TH JUDICIAL CIRCUIT IN AND FOR SARASOTA COUNTY, FLORIDA

CASE NO.: 2009 CA 010118 NC BANK OF AMERICA, N.A., Plaintiff, vs. LOUANN M. NUDI, et al. Defendants,

NOTICE IS HEREBY GIVEN pursuant to a Final Judgment of Foreclosure dated November 14, 2013, entered in Civil Case No.: 2009 CA 010118 NC of the 12th Judicial Circuit in Sarasota, Sarasota County, Florida, Karen E. Rushing, the Clerk of the Court, will sell to the highest and best bidder for cash online at www.sarasota.realforeclose.com at 9:00 A.M. EST on the 8 day of January 2014 the following described property as set forth in said Final Judgment, to-wit:

LOT 10, IN BLOCK 38, OF MANASOTA LAND AND TIMBER COMPANY SUBDIVISION, ACCORDING TO THE PLAT THEREOF, AS RECORDED IN PLAT BOOK A, AT PAGE 27, OF THE PUBLIC RECORDS OF SARASOTA COUNTY, FLORIDA.

Any person claiming an interest in the surplus from the sale, if any, other than the property owner as of the date of the lis pendens must file a claim within 60 days after the sale.

If you are a person with a disability who needs any accommodation in this proceeding, you are entitled, at no cost to you, to the provision of certain assistance. Please contact the Sarasota County Jury Office, P.O. Box 3079, Sarasota, Florida 34230-3079, (941)861-7400, at least seven (7) days before your scheduled court appearance, or immediately upon receiving this notification if the time before the scheduled appearance is less than seven (7) days; if you are hearing or voice impaired, call 711.

Dated this 16 day of December, 2013. By: /s/ Maria Fernandez-Gomez Maria Fernandez-Gomez, Esq. Fla. Bar No. 998494

TRIPP SCOTT, P.A. Attorneys for Plaintiff 110 S.E. Sixth St., 15th Floor Fort Lauderdale, FL 33301 Telephone (954) 765-2999 Facsimile (954) 761 8475 Email: mfg@trippscott.com 13-021527 December 20, 27, 2013 13-05958S

FIRST INSERTION

NOTICE OF FORECLOSURE SALE IN THE CIRCUIT COURT OF THE 12TH JUDICIAL CIRCUIT, IN AND FOR SARASOTA COUNTY, FLORIDA

CIVIL DIVISION: CASE NO.: 2010 CA 001668 NC BANK OF AMERICA, N.A., Plaintiff, vs. PAUL GLUSHKU A/K/A PAUL P. GLUSHKU; SVETLANA GLUSHKU; UNKNOWN TENANT(S); IN POSSESSION OF THE SUBJECT PROPERTY, Defendants.

NOTICE IS HEREBY GIVEN pursuant to Final Judgment of Foreclosure dated the 3rd day of December, 2013, and entered in Case No. 2010 CA 001668 NC, of the Circuit Court of the 12TH Judicial Circuit in and for Sarasota County, Florida, wherein BANK OF AMERICA, N.A. is the Plaintiff and PAUL GLUSHKU A/K/A PAUL P. GLUSHKU; SVETLANA GLUSHKU; UNKNOWN TENANT(S); IN POSSESSION OF THE SUBJECT PROPERTY are defendants. The Clerk of this Court shall sell to the highest and best bidder for cash electronically at www.sarasota.realforeclose.com at 9:00 AM on the 13th day of January, 2014, the following described property as set forth in said Final Judgment, to wit:

LOT 1, BLOCK 2405, 49TH ADDITION TO PORT CHARLOTTE SUBDIVISION, ACCORDING TO THE PLAT THEREOF RECORDED IN PLAT BOOK 13,

FIRST INSERTION

NOTICE OF FORECLOSURE SALE IN THE CIRCUIT COURT OF THE 12TH JUDICIAL CIRCUIT IN AND FOR SARASOTA COUNTY, FLORIDA

CASE NO.: 2009 CA 013302 NC BAC HOME LOANS SERVICING, L.P. F/K/A COUNTRYWIDE HOME LOANS SERVICING, L.P. Plaintiff, vs. THERESA BOROS, et al. Defendants,

NOTICE IS HEREBY GIVEN pursuant to an Order entered Resetting the Foreclosure Sale dated November 27, 2013 entered in Civil Case No.: 2009 CA 013302 NC of the Circuit Court of the 12TH Judicial Circuit in and for Sarasota County, Florida, Karen E. Rushing Clerk of the Circuit Court will sell to the highest and best bidder for cash at www.sarasota.realforeclose.com at 9:00 am on the 2nd day of January, 2013 the following described property as set forth in said Summary Final Judgment, to-wit:

LOT 2, VENETIAN GOLF & RIVER CLUB, PHASE 3-1, ACCORDING TO THE PLAT THEREOF RECORDED IN PLAT BOOK 45, PAGE 6, OF THE PUBLIC RECORDS OF SARASOTA COUNTY, FLORIDA

Any person claiming an interest in the surplus from the sale, if any, other than the property owner as of the date of the lis pendens must file a claim within 60 days after the sale.

If you are a person with a disability who needs any accommodation in order to participate in this proceeding, you are entitled, at no cost to you, to the provision of certain assistance. Please contact the Sarasota County Jury Office, P.O. Box 3079, Sarasota, Florida 34230-3079, (941)861-7400, at least seven (7) days before your scheduled court appearance, or immediately upon receiving this notification if the time before the scheduled appearance is less than seven (7) days; if you are hearing or voice impaired, call 711.

Dated this 16th day of December, 2013. By: /s/ Maria Fernandez-Gomez Maria Fernandez-Gomez, Esq. Fla. Bar No. 998494

TRIPP SCOTT, P.A. Attorneys for Plaintiff 110 S.E. Sixth St., 15th Floor Fort Lauderdale, FL 33301 Telephone (954) 765-2999 Facsimile (954) 761 8475 Email: mfg@trippscott.com 11-004588 December 20, 27, 2013 13-05959S

NOTICE OF FORECLOSURE SALE IN THE CIRCUIT COURT OF THE 12TH JUDICIAL CIRCUIT, IN AND FOR SARASOTA COUNTY, FLORIDA

CASE NO.: 58-2010-CA-001739 NC BANK OF AMERICA, N.A. AS SUCCESSOR BY MERGER TO BAC HOME LOANS SERVICING, L.P. FKA COUNTRYWIDE HOME LOANS SERVICING, L.P., Plaintiff, vs. UNKNOWN HEIRS, BENEFICIARIES, DEVISEES, ASSIGNEES, LIENORS, CREDITORS, TRUSTEES AND ALL OTHERS WHO MAY CLAIM AN INTEREST IN THE ESTATE OF ROSALIE MURPHY, DECEASED; GORDON MIKITKA; GERARD STEPHEN MURPHY; KEVIN PATRICK MURPHY; SEAN DAVID MURPHY; UNKNOWN SPOUSE OF ROSALIE MURPHY; UNKNOWN TENANT(S); IN POSSESSION OF THE SUBJECT PROPERTY, Defendants.

NOTICE IS HEREBY GIVEN pursuant to Final Judgment of Foreclosure dated the 3rd day of December, 2013, and entered in Case No. 58-2010-CA-001739 NC, of the Circuit Court of the 12TH Judicial Circuit in and for Sarasota County, Florida, wherein BANK OF AMERICA, N.A. AS SUCCESSOR BY MERGER TO BAC HOME LOANS SERVICING, L.P. FKA COUNTRYWIDE HOME LOANS SERVICING, L.P. is the Plaintiff and UNKNOWN HEIRS, BENEFICIARIES, DEVISEES, ASSIGNEES, LIENORS, CREDITORS, TRUSTEES AND ALL OTHERS WHO MAY CLAIM AN INTEREST IN THE ESTATE OF ROSALIE MURPHY, DECEASED; GORDON MIKITKA; GERARD STEPHEN MURPHY; KEVIN PATRICK MURPHY; SEAN DAVID MURPHY and UNKNOWN TENANT(S) IN POSSESSION OF THE SUBJECT PROPERTY

are defendants. The Clerk of this Court shall sell to the highest and best bidder for cash electronically at www.sarasota.realforeclose.com at 9:00 AM on the 13th day of January, 2014, the following described property as set forth in said Final Judgment, to wit:

SEE EXHIBIT "A" EXHIBIT "A" 10-01050470 THE FOLLOWING PROPERTY SITUATED IN SARASOTA COUNTY, FLORIDA, TO WIT:

A PARCEL IN THE SW 1/4, SECTION 13, TOWNSHIP 36 SOUTH, RANGE 18 EAST, DESCRIBED AS: BEGINNING AT THE NW CORNER OF LOT 17, BLOCK B PEACEFUL VISTA HOMES, AS PER PLAT THEREOF RECORDED IN PLAT BOOK 5, PAGE 40, OF THE PUBLIC RECORDS OF SARASOTA COUNTY, FLORIDA; THENCE NORTH 1 DEGREE 34 MINUTES WEST, ALONG THE EXTENSION OF THE WEST LINE OF SAID LOT 17, FOR A DISTANCE OF 100 FEET TO THE POINT OF BEGINNING; THENCE CONTINUE NORTH 1 DEGREE 34 MINUTES WEST, A DISTANCE OF 92 FEET; THENCE NORTH 88 DEGREES 26 MINUTES AND PARALLEL TO THE NORTH LINE OF SAID LOT 17, A DISTANCE OF 125 FEET; THENCE SOUTH 1 DEGREE 34 MINUTES EAST, 92 FEET; THENCE SOUTH 88 DEGREES 26 MINUTES WEST, 125 FEET TO THE POINT OF BEGINNING;

ALSO: THE SOUTH 25 FEET OF THE FOLLOWING DESCRIBED PARCEL: BEGIN AT THE NW CORNER OF LOT 17, BLOCK B, PEACEFUL VISTA HOMES, AS PER PLAT THEREOF AS RECORDED IN PLAT BOOK

FIRST INSERTION

NOTICE OF RESCHEDULED SALE IN THE CIRCUIT COURT OF THE TWELFTH JUDICIAL CIRCUIT IN AND FOR SARASOTA COUNTY, FLORIDA

CIVIL ACTION CASE NO.: 2008 CA 010630 SC DIVISION: A

U.S. BANK NATIONAL ASSOCIATION, AS TRUSTEE, FOR THE BENEFIT OF CITIGROUP MORTGAGE LOAN TRUST INC. ASSET-BACKED PASS-THROUGH CERTIFICATES SERIES 2007-AHL2, Plaintiff, vs. SCOTT E. LONGBRAKE A/K/A SCOTT LONGBRAKE, et al, Defendant(s).

NOTICE IS HEREBY GIVEN Pursuant to an Order Rescheduling Foreclosure Sale dated on or about December 3, 2013, and entered in Case No. 2008 CA 010630 SC of the Circuit Court of the Twelfth Judicial Circuit in and for Sarasota County, Florida in which U.S. Bank National Association, As Trustee, For The Benefit Of Citigroup Mortgage Loan Trust Inc. Asset-Backed Pass-Through Certificates Series 2007-AHL2, is the Plaintiff and Scott E. Longbrake A/K/A Scott Longbrake, Jane Doe N/K/A Leslie Cole, John Doe N/K/A Carl Cole, Unknown Spouse Of Scott E. Longbrake A/K/A Scott Longbrake, are defendants, the Sarasota County Clerk of the Circuit Court will sell to the highest and best bidder for cash in/on the Internet: www.sarasota.realforeclose.com, Sarasota County, Florida at 9:00am on the 7th day of January, 2014, the following described

property as set forth in said Final Judgment of Foreclosure: LOT 19, BLOCK 444, 9TH ADDITION TO PORT CHARLOTTE SUBDIVISION, A SUBDIVISION ACCORDING TO THE PLAT THEREOF, RECORDED IN PLAT BOOK 12, PAGES 21, 21A THROUGH 21S, OF THE PUBLIC RECORDS OF SARASOTA COUNTY, FLORIDA.

A/K/A 2483 ALTOONA AVENUE, NORTH PORT, FL 34286 Any person claiming an interest in the surplus from the sale, if any, other than the property owner as of the date of the Lis Pendens must file a claim within 60 days after the sale.

If you are a person with a disability who needs any accommodation in order to participate in this proceeding, you are entitled, at no cost to you, to the provision of certain assistance. Please contact the Sarasota County Jury Office, P.O. Box 3079, Sarasota, Florida 34230-3079, (941)861-7400, at least seven (7) days before your scheduled court appearance, or immediately upon receiving this notification if the time before the scheduled appearance is less than seven (7) days; if you are hearing or voice impaired, call 711.

Albertelli Law Attorney for Plaintiff P.O. Box 23028 Tampa, FL 33623 (813) 221-4743 (813) 221-9171 facsimile eService: servealaw@albertellilaw.com 10-60147 December 20, 27, 2013 13-05882S

FIRST INSERTION

NOTICE OF PUBLIC SALE: NOTICE OF PUBLIC SALE: J&G WFR Inc dba Direct Towing gives Notice of Foreclosure of Lien and intent to sell these vehicles on 1/3/2014 9:00:00 AM at 3951 N Osprey Ave, Sarasota, FL 34234 pursuant to subsection 713.78 of the Florida Statutes. J&G WFR Inc dba Direct Towing reserves the right to accept or reject any and/or all bids.

KLAVB6922YB272550 2000 DAEW LEGANZA SE 1LNCM93E3MY718013 1991 LINC MARK VII LSC 1G3WH12M6SD319293 1995 OLDS CUTLASS SUPREME SL 1G1JC1249Y7218712 2000 CHEV CAVALIER December 20, 2013 13-05964S

FIRST INSERTION

NOTICE OF FORECLOSURE SALE IN THE CIRCUIT COURT OF THE 12TH JUDICIAL CIRCUIT, IN AND FOR SARASOTA COUNTY, FLORIDA

CASE NO.: 2012 CA 004676 NC NATIONSTAR MORTGAGE, LLC Plaintiff Vs. BLANCA GARDINI A/K/A BLANCA I. GARDINI, INDIVIDUALLY AND AS TRUSTEE OF THE BIANCA I. GARDINI INTER VIVOS TRUST; ET AL Defendants

NOTICE IS HEREBY GIVEN pursuant to an Order Rescheduling Foreclosure Sale dated November 20th, 2013, and entered in Case No. 2012 CA 004676 NC, of the Circuit Court of the Twelfth Judicial Circuit in and for Sarasota County, Florida. Nationstar Mortgage, LLC, Plaintiff and BLANCA GARDINI A/K/A BLANCA I. GARDINI, INDIVIDUALLY AND AS TRUSTEE OF THE BIANCA I. GARDINI INTER VIVOS TRUST; ET AL, are defendants. The Clerk of the Court will sell to the highest and best bidder for cash www.sarasota.realforeclose.com, SALE BEGINNING AT 9:00 AM ON THE PRESCRIBED DATE this January 15th, 2014, the following described property as set forth in the Final Judgment, dated September 9th, 2013:

LOT 31, BLOCK 631, 14TH ADDITION TO PORT CHARLOTTE SUBDIVISION, A SUBDIVISION ACCORDING TO THE PLAT THEREOF,

RECORDED IN PLAT BOOK 13, PAGE 13, OF THE PUBLIC RECORDS OF SARASOTA COUNTY, FLORIDA.

Property Address: 6121 Surf Avenue, North Port, FL 34286-0000 A person claiming an interest in the surplus from the sale, if any, other than the property owner as of the date of the lis pendens must file a claim within 60 days after the sale.

This notice is provided pursuant to Administrative Order No.2.065. If you are a person with a disability who needs any accommodation in order to participate in this proceeding, you are entitled, at no cost to you, to the provision of certain assistance. Please contact the Sarasota County Jury Office, P.O. Box 3079, Sarasota, Florida 34230-3079, (941)861-7400, at least seven (7) days before your scheduled court appearance, or immediately upon receiving this notification if the time before the scheduled appearance is less than seven (7) days; if you are hearing or voice impaired, call 711.

Dated this 16 day of December, 2013. By: Maria Camps, Esquire F. Bar #930441 FLEService@udren.com UDREN LAW OFFICES, P.C. 2101 West Commercial Blvd., Suite 5000 Fort Lauderdale, FL 33309 Telephone 954-378-1757 Fax 954-378-1758 MJU #11090600-1 December 20, 27, 2013 13-05960S

RE-NOTICE OF FORECLOSURE SALE IN THE CIRCUIT COURT OF THE TWELFTH JUDICIAL CIRCUIT, IN AND FOR SARASOTA COUNTY, FLORIDA

Case No. 2012 CA 004676 NC NATIONSTAR MORTGAGE, LLC Plaintiff Vs. BLANCA GARDINI A/K/A BLANCA I. GARDINI, INDIVIDUALLY AND AS TRUSTEE OF THE BIANCA I. GARDINI INTER VIVOS TRUST; ET AL Defendants

NOTICE IS HEREBY GIVEN pursuant to an Order Rescheduling Foreclosure Sale dated November 20th, 2013, and entered in Case No. 2012 CA 004676 NC, of the Circuit Court of the Twelfth Judicial Circuit in and for Sarasota County, Florida. Nationstar Mortgage, LLC, Plaintiff and BLANCA GARDINI A/K/A BLANCA I. GARDINI, INDIVIDUALLY AND AS TRUSTEE OF THE BIANCA I. GARDINI INTER VIVOS TRUST; ET AL, are defendants. The Clerk of the Court will sell to the highest and best bidder for cash www.sarasota.realforeclose.com, SALE BEGINNING AT 9:00 AM ON THE PRESCRIBED DATE this January 15th, 2014, the following described property as set forth in the Final Judgment, dated September 9th, 2013:

5, PAGE 40, OF THE PUBLIC RECORDS OF SARASOTA COUNTY, FLORIDA; THENCE NORTH 1 DEGREE 34 MINUTES WEST ALONG THE WEST LINE EXTENDED OF SAID LOT 17, 192 FEET FOR A POINT OF BEGINNING; THENCE NORTH 1 DEGREE 34 MINUTES WEST, 1107.82 FEET TO THE NORTH LINE OF THE SW 1/4, SECTION 13, TOWNSHIP 36 SOUTH, RANGE 18 EAST; THENCE NORTH 89 DEGREES 32 MINUTES 30 SECONDS EAST ALONG SAID NORTH LINE, 175.03 FEET; THENCE SOUTH 1 DEGREE 34 MINUTES EAST, 954.85 FEET; THENCE SOUTH 22 DEGREES 57 MINUTES 30 SECONDS WEST, 120.44 FEET; THENCE SOUTH 88 DEGREES 26 MINUTES WEST, 125 FEET TO THE POINT OF BEGINNING; BEING IN SECTION 13, TOWNSHIP 36 SOUTH, RANGE 18 EAST;

TOGETHER WITH A NON-EXCLUSIVE PERPETUAL EASEMENT 50 FEET WIDE FOR INGRESS AND EGRESS OVER AND UPON THE FOLLOWING DESCRIBED PARCEL:

BEGIN AT THE NORTHEAST CORNER OF LOT 17, BLOCK B, PEACEFUL VISTA HOMES SUBDIVISION, AS RECORDED IN PLAT BOOK 6, PAGE 40, OF THE PUBLIC RECORDS OF SARASOTA COUNTY, FLORIDA; THENCE NORTH ALONG AN EXTENSION OF THE WEST LINE OF WILLIS AVENUE A DISTANCE OF 192 FEET; THENCE EAST AT RIGHT ANGLE A DISTANCE OF 50 FEET; THENCE SOUTH A DISTANCE OF 192 FEET TO THE INTERSECTION OF THE EAST LINE

OF SAID WILLIS AVENUE; THENCE WEST 50 FEET TO THE POINT OF BEGINNING.

BEING THE SAME PROPERTY CONVEYED TO ROSALIE MURPHY BY DEED FROM WILLIAM M. ESTES AND LOUISE C. ESTES, HUSBAND AND WIFE RECORDED 05/09/1990 IN DEED BOOK 2209 PAGE 1298; IN THE PUBLIC RECORDS OF SARASOTA COUNTY, FLORIDA.

ANY PERSON CLAIMING AN INTEREST IN THE SURPLUS FROM THE SALE, IF ANY, OTHER THAN THE PROPERTY OWNER AS OF THE DATE OF THE LIS PENDENS MUST FILE A CLAIM WITHIN 60 DAYS AFTER THE SALE.

If you are a person with a disability who needs any accommodation in order to participate in this proceeding, you are entitled, at no cost to you, to the provision of certain assistance. Please contact the Sarasota County Jury Office, P.O. Box 3079, Sarasota, Florida 34230-3079, (941)861-7400, at least seven (7) days before your scheduled court appearance, or immediately upon receiving this notification if the time before the scheduled appearance is less than seven (7) days; if you are hearing or voice impaired, call 711.

Dated this 17 day of December, 2013. By: Michael D.P. Phillips Bar #653268 Choice Legal Group, P.A. 1800 NW 49th Street, Suite 120 Fort Lauderdale, Florida 33309 Telephone: (954) 453-0365 Facsimile: (954) 771-6052 Toll Free: 1-800-441-2438 DESIGNATED PRIMARY E-MAIL FOR SERVICE PURSUANT TO FLA R. JUD. ADMIN 2.516 eservice@clegalgroup.com 10-01886 December 20, 27, 2013 13-05999S

FIRST INSERTION

RE-NOTICE OF FORECLOSURE SALE IN THE CIRCUIT COURT OF THE TWELFTH JUDICIAL CIRCUIT, IN AND FOR SARASOTA COUNTY, FLORIDA

Case No. 2012 CA 004676 NC NATIONSTAR MORTGAGE, LLC Plaintiff Vs. BLANCA GARDINI A/K/A BLANCA I. GARDINI, INDIVIDUALLY AND AS TRUSTEE OF THE BIANCA I. GARDINI INTER VIVOS TRUST; ET AL Defendants

NOTICE IS HEREBY GIVEN pursuant to an Order Rescheduling Foreclosure Sale dated November 20th, 2013, and entered in Case No. 2012 CA 004676 NC, of the Circuit Court of the Twelfth Judicial Circuit in and for Sarasota County, Florida. Nationstar Mortgage, LLC, Plaintiff and BLANCA GARDINI A/K/A BLANCA I. GARDINI, INDIVIDUALLY AND AS TRUSTEE OF THE BIANCA I. GARDINI INTER VIVOS TRUST; ET AL, are defendants. The Clerk of the Court will sell to the highest and best bidder for cash www.sarasota.realforeclose.com, SALE BEGINNING AT 9:00 AM ON THE PRESCRIBED DATE this January 15th, 2014, the following described property as set forth in the Final Judgment, dated September 9th, 2013:

LOT 31, BLOCK 631, 14TH ADDITION TO PORT CHARLOTTE SUBDIVISION, A SUBDIVISION ACCORDING TO THE PLAT THEREOF,

RECORDED IN PLAT BOOK 13, PAGE 13, OF THE PUBLIC RECORDS OF SARASOTA COUNTY, FLORIDA.

Property Address: 6121 Surf Avenue, North Port, FL 34286-0000 A person claiming an interest in the surplus from the sale, if any, other than the property owner as of the date of the lis pendens must file a claim within 60 days after the sale.

This notice is provided pursuant to Administrative Order No.2.065. If you are a person with a disability who needs any accommodation in order to participate in this proceeding, you are entitled, at no cost to you, to the provision of certain assistance. Please contact the Sarasota County Jury Office, P.O. Box 3079, Sarasota, Florida 34230-3079, (941)861-7400, at least seven (7) days before your scheduled court appearance, or immediately upon receiving this notification if the time before the scheduled appearance is less than seven (7) days; if you are hearing or voice impaired, call 711.

Dated this 16 day of December, 2013. By: Maria Camps, Esquire F. Bar #930441 FLEService@udren.com UDREN LAW OFFICES, P.C. 2101 West Commercial Blvd., Suite 5000 Fort Lauderdale, FL 33309 Telephone 954-378-1757 Fax 954-378-1758 MJU #11090600-1 December 20, 27, 2013 13-05960S

RECORDED IN PLAT BOOK 13, PAGE 13, OF THE PUBLIC RECORDS OF SARASOTA COUNTY, FLORIDA.

Property Address: 6121 Surf Avenue, North Port, FL 34286-0000 A person claiming an interest in the surplus from the sale, if any, other than the property owner as of the date of the lis pendens must file a claim within 60 days after the sale.

This notice is provided pursuant to Administrative Order No.2.065. If you are a person with a disability who needs any accommodation in order to participate in this proceeding, you are entitled, at no cost to you, to the provision of certain assistance. Please contact the Sarasota County Jury Office, P.O. Box 3079, Sarasota, Florida 34230-3079, (941)861-7400, at least seven (7) days before your scheduled court appearance, or immediately upon receiving this notification if the time before the scheduled appearance is less than seven (7) days; if you are hearing or voice impaired, call 711.

Dated this 16 day of December, 2013. By: Maria Camps, Esquire F. Bar #930441 FLEService@udren.com UDREN LAW OFFICES, P.C. 2101 West Commercial Blvd., Suite 5000 Fort Lauderdale, FL 33309 Telephone 954-378-1757 Fax 954-378-1758 MJU #11090600-1 December 20, 27, 2013 13-05960S

NOTICE OF PUBLIC AUCTION Notice is hereby given that on 1/3/14 at 10:30 am, the following mobile homes will be sold at public auction pursuant to F.S. 715.109: 1970 ROCK #12193. Last Tenants: Margaret Tibbits Hiler & Johnna Roberts Norment. 1972 FEST #32J102TS791. Last Tenant: Dean Anthony Tersigni. Sale to be held at Realty Systems- Arizona Inc 4000 Tuttle Ave Sarasota, FL 34234 813-241-8269 December 20, 27, 2013 13-05981S

NOTICE OF PUBLIC SALE In Accordance with Florida State Law Self Storage Facility Act 83.801-83.809, ss.4(a) and to satisfy an operator's lien, the contents of the following units will be sold at a public auction to the highest bidder for cash on: Date: January 9th 2014, 4:00 PM or AFTER At: Patriot Self Storage, 6029 Talon Bay Dr., North Port, FL 34287 Household Items - Unit #1315 Jeremy Dean Jackson Gordon December 20, 27, 2013 13-05965S

SAVE TIME



E-mail your Legal Notice

legal@businessobserverfl.com

Business Observer

Wednesday
Noon Deadline
Friday Publication

FIRST INSERTION

NOTICE OF FORECLOSURE SALE IN THE CIRCUIT COURT OF THE TWELFTH JUDICIAL CIRCUIT IN AND FOR SARASOTA COUNTY, FLORIDA

GENERAL JURISDICTION DIVISION
CASE NO. 2013 CA 003958 NC
CITIMORTGAGE, INC.,
Plaintiff, vs.

PATRICK D. HORTON A/K/A PATRICK HORTON, et al.
Defendant(s).

NOTICE IS HEREBY GIVEN pursuant to a Final Judgment of Foreclosure dated NOVEMBER 21, 2013, and entered in Case No. 2013 CA 003958 NC of the Circuit Court of the Twelfth Judicial Circuit in and for Sarasota County, Florida, wherein CITIMORTGAGE, INC., is the Plaintiff and PATRICK D. HORTON A/K/A PATRICK HORTON; JPMORGAN CHASE BANK, NA; UNKNOWN TENANTS are the Defendant(s). Karen Rushing as the Clerk of the Circuit Court will sell to the highest and best bidder for cash, www.sarasota.realforeclose.com, at 09:00 AM on JANUARY 6, 2014, the following described property as set forth in said Final Judgment, to wit:

LOT 4, BLOCK 358, 10TH ADDITION TO PORT CHARLOTTE SUBDIVISION, ACCORDING TO THE PLAT THEREOF, RECORDED IN PLAT BOOK 12, PAGE 22, OF THE PUBLIC RECORDS OF SARASOTA COUNTY, FLORIDA.

Any person claiming an interest in the surplus from the sale, if any, other than the property owner as of the date of the lis pendens must file a claim within 60 days after the sale.

If you are a person with a disability who needs any accommodation in order to participate in this proceeding, you are entitled, at no cost to you, to the provision of certain assistance. Please contact the Sarasota County Jury Office, P.O. Box 3079, Sarasota, Florida 34230-3079, (941)861-7400, at least seven (7) days before your scheduled court appearance, or immediately upon receiving this notification if the time before the scheduled appearance is less than seven (7) days; if you are hearing or voice impaired, call 711.

Dated this 12th day of December, 2013.

By: Liana R. Hall
FL Bar No. 73813
for Geoffrey A. Levy
Florida Bar: 83392

Submitted by:
Robertson, Anschutz & Schneider, PL
Attorneys for Plaintiff
6409 Congress Avenue, Suite 100
Boca Raton, Florida 33487
12-14674
December 20, 27, 2013 13-05924S

FIRST INSERTION

Notice Under Fictitious Name Law Pursuant to Section 865.09, Florida Statutes

NOTICE IS HEREBY GIVEN that the undersigned, desiring to engage in business under fictitious name of Hill Law Firm, P.A. located at 458 S. Tamiami Trail, in the County of Sarasota in the City of Osprey, Florida 34229 intends to register the said name with the Division of Corporations of the Florida Department of State, Tallahassee, Florida.

Dated at Sarasota, Florida, this 17th day of December, 2013.
The Law Office of Cindy Hill Ford, P.A.
December 20, 2013 13-05982S

FIRST INSERTION

NOTICE OF PUBLIC SALE OF PERSONAL PROPERTY METRO SELF STORAGE

Notice is hereby given that the undersigned self storage unit(s) will be sold at a public sale by competitive bidding, in their entirety to the highest bidder, on or after date and time below to satisfy the lien of Metro Self Storage for rental and other charges due from the undersigned. The said property has been stored and generally described below is located at the respective address. The sale will begin at the date and time below on or after on said date and will continue hour by hour until all units are sold. Auctioneer Lic# AU4167 and AB2825, 10% Buyers Premium.
Tuesday January 7 2014
10:00 AM

619 Cattleman Rd
Sarasota, FL 34232
B8 Danny Huddleston
T12 Lori Mudge
The contents consist of general, household and miscellaneous items. The terms of the sale will be cash only and must be paid for at the time of the sale. All goods are sold as is. Metro Self Storage reserves the right to withdraw any or all units for the sale at any time. All contents must be removed within 48 hours or sooner.
December 20, 27, 2013 13-05947S

FIRST INSERTION

NOTICE OF SALE IN THE CIRCUIT COURT OF THE TWELFTH JUDICIAL CIRCUIT IN AND FOR SARASOTA COUNTY, FLORIDA

CIVIL DIVISION
Case #: 2008-CA-019302-NC
DIVISION: A

EverHome Mortgage Company
Plaintiff, vs.-
Robert L. Charnley and Veronica Charnley, Husband and Wife;
Citifinancial Equity Services, Inc.; Clerk of the Circuit Court of Sarasota County, Florida
Defendant(s).

NOTICE IS HEREBY GIVEN pursuant to an Order dated August 28, 2013, entered in Civil Case No. 2008-CA-019302-NC of the Circuit Court of the 12th Judicial Circuit in and for Sarasota County, Florida, wherein EverHome Mortgage Company, Plaintiff and Robert L. Charnley and Veronica Charnley, Husband and Wife are defendant(s), I, Clerk of Court, Karen E. Rushing, will sell to the highest and best bidder for cash VIA THE INTERNET AT WWW.SARASOTA.REALFORECLOSE.COM, AT 9:00 A.M. on January 7, 2014, the following described property as set forth in said Final Judgment, to-wit:

LOT 30, BLOCK 1812, 37TH ADDITION TO PORT CHARLOTTE SUBDIVISION, A SUBDIVISION ACCORDING TO THE PLAT THEREOF, AS RECORDED IN PLAT BOOK 16, PAGES 4, 4A-4H, OF THE PUBLIC RECORDS OF SARASOTA COUNTY, FLORIDA.

ANY PERSON CLAIMING AN INTEREST IN THE SURPLUS FROM THE SALE, IF ANY, OTHER THAN THE PROPERTY OWNER AS OF THE DATE OF THE LIS PENDENS MUST FILE A CLAIM WITHIN 60 DAYS AFTER THE SALE.

If you are a person with a disability who needs any accommodation in order to participate in this proceeding, you are entitled, at no cost to you, to the provision of certain assistance. Please contact the Sarasota County Jury Office, P.O. Box 3079, Sarasota, Florida 34230-3079, (941)861-7400, at least seven (7) days before your scheduled court appearance, or immediately upon receiving this notification if the time before the scheduled appearance is less than seven (7) days; if you are hearing or voice impaired, call 711.

Submitted By:
ATTORNEY FOR PLAINTIFF:
SHAPIRO, FISHMAN & GACHÉ, LLP
2424 North Federal Highway, Suite 360
Boca Raton, Florida 33431
(561) 998-6700
(561) 998-6707
08-117432 FCO1 AMC
December 20, 27, 2013 13-05905S

FIRST INSERTION

AMENDED NOTICE OF SALE UNDER F.S. CHAPTER 45 IN THE CIRCUIT COURT OF THE TWELFTH JUDICIAL CIRCUIT, IN AND FOR SARASOTA COUNTY, FLORIDA

CASE NO: 2011-CA-004660-NC
ACM LIBERTY RESIDENTIAL LLC,
Plaintiff, v.
PETRONILLA FERMIN PEREZ, et al.,
Defendants.

NOTICE IS GIVEN that, in accordance with the Final Judgment of Foreclosure dated October 21, 2013 in the above styled cause, I will sell to the highest and best bidder for cash ONLINE AT www.sarasota.realforeclose.com, at 9:00 a.m. on January 21, 2014, the following described property:

Property Address: 4254 LA ROSA AVENUE, NORTH PORT, FL 34285.
Legal Description: LOT 19, BLOCK 543, OF THE 18TH ADDITION TO PORT CHARLOTTE SUBDIVISION, AS PER PLAT THEREOF RECORDED IN PLAT BOOK 14, PAGES 6, 6A THROUGH 6V OF THE PUBLIC RECORDS OF SARASOTA COUNTY, FLORIDA.

This Notice of Sale will be published in the BUSINESS OBSERVER by Panza, Maurer & Maynard, P.A., 3600 North Federal Highway, 3rd Floor, Fort Lauderdale, Florida, 33308-6225, (954)390-0100.

ANY PERSON CLAIMING AN INTEREST IN THE SURPLUS FROM THE SALE, IF ANY, OTHER THAN THE PROPERTY OWNER AS OF THE DATE OF THE LIS PENDENS MUST FILE A CLAIM WITHIN 60 DAYS AFTER THE SALE.

If you are a person with a disability who needs any accommodation in order to participate in this proceeding, you are entitled, at no cost to you, to the provision of certain assistance. Please contact the Sarasota County Jury Office, P.O. Box 3079, Sarasota, Florida 34230-3079, (941)861-7400, at least seven (7) days before your scheduled court appearance, or immediately upon receiving this notification if the time before the scheduled appearance is less than seven (7) days; if you are hearing or voice impaired, call 711.

BY: /s/ Pascale Achille
PASCALE ACHILLE, ESQ.
Florida Bar No. 13403
PANZA, MAURER & MAYNARD, P.A.
Attorneys for Plaintiff
3600 North Federal Highway,
3rd Floor
Fort Lauderdale, FL 33308-6225
(954)390-0100
(954)390-7991 fax
December 20, 27, 2013 13-05955S

FIRST INSERTION

NOTICE OF SALE IN THE CIRCUIT COURT OF THE TWELFTH JUDICIAL CIRCUIT, IN AND FOR SARASOTA COUNTY, FLORIDA

CASE NO. 2009 CA 000246 NC
NATIONSTAR MORTGAGE, LLC,
Plaintiff, v.
DION THORNTON, et al.,
Defendants.

Notice is hereby given, pursuant to the Uniform Final Judgment of Mortgage Foreclosure entered in this case on October 17, 2013, in the Circuit Court of the Twelfth Judicial Circuit in and for Sarasota County, Florida, the property situated in Sarasota County, Florida, described as:

CONDOMINIUM UNIT NO. 204, TIVOLI-BY-THE-SEA CONDOMINIUM, ACCORDING TO THE DECLARATION THEREOF, AS RECORDED IN OFFICIAL RECORDS BOOK 1076, PAGE 1899, AND AS PER PLAT RECORDED IN CONDOMINIUM PLAT BOOK 8, PAGE 38, BOTH OF THE PUBLIC RECORDS OF SARASOTA COUNTY, FLORIDA.

Property Address: 625 Beach Road Unit 204, Sarasota, FL 34242
including the building, appurtenances, and fixtures located therein, will be sold at public sale, to the highest bidder, for cash, electronically at www.sarasota.realforeclose.com, on January 6, 2014 at 9:00 a.m.

Any persons claiming an interest in the surplus from the sale, if any, other than the property owner, as of the date of the Lis Pendens, must file a claim within 60 days after the sale.

If you are a person with a disability who needs any accommodation in order to participate in this proceeding, you are entitled, at no cost to you, to the provision of certain assistance. Please contact the Sarasota County Jury Office, P.O. Box 3079, Sarasota, Florida 34230-3079, (941)861-7400, at least seven (7) days before your scheduled court appearance, or immediately upon receiving this notification if the time before the scheduled appearance is less than seven (7) days; if you are hearing or voice impaired, call 711.

Dated this 16th day of December 2013.
BROAD AND CASSEL
Edward Welch, Esquire
Florida Bar No. 685089
Attorneys for Plaintiff
One North Clematis Street, \ Suite 500
West Palm Beach, FL 33401
Telephone: (561) 832-3300
Facsimile: (561) 655-1109
Email: ewelch@broadandcassel.com
December 20, 27, 2013 13-05950S

FIRST INSERTION

NOTICE OF SALE IN THE CIRCUIT COURT OF THE TWELFTH JUDICIAL CIRCUIT, IN AND FOR SARASOTA COUNTY, FLORIDA

CASE NO.: 2013 CA 6851 NC
STEPHAN A. WITZER, as Trustee
u/a/d February 7, 1985,
Plaintiff, vs.
JAMILETH ZURITA,
Defendant.

NOTICE IS HEREBY GIVEN pursuant to an Order of Final Judgment of Foreclosure dated December 16, 2013 entered in Civil Case No.: 2013 CA 6851 NC, of the Circuit Court of the Twelfth Judicial Circuit in and for Sarasota County, Florida, wherein Stephen A. Witzer, as Trustee u/a/d February 7, 1985, is the Plaintiff and Jamileth Zurita is the Defendant. I will sell to the highest bidder for cash via foreclosure sale conducted via the Internet at www.sarasota.realforeclose.com at 9:00 a.m. on January 28, 2014 the following described property as set forth in said Final Judgment, to-wit:

Lot 8, Block 1296, 26th Addition to Port Charlotte Subdivision, a subdivision according to the plat thereof recorded in Plat Book 15, pages 3, 3A thru 3S, of the Public Records of Sarasota County, Florida.

ANY PERSON CLAIMING AN INTEREST IN THE SURPLUS FROM THE SALE, IF ANY, OTHER THAN THE PROPERTY OWNER AS OF THE DATE OF THE LIS PENDENS MUST FILE A CLAIM WITHIN 60 DAYS AFTER THE SALE.

If you are a person with a disability who needs any accommodation in order to participate in this proceeding, you are entitled, at no cost to you, to the provision of certain assistance. Please contact the Sarasota County Jury Office, P.O. Box 3079, Sarasota, Florida 34230-3079, (941)861-7400, at least seven (7) days before your scheduled court appearance, or immediately upon receiving this notification if the time before the scheduled appearance is less than seven (7) days; if you are hearing or voice impaired, call 711.

DATED at Sarasota, Sarasota County, Florida this 17th day of December, 2013.
ALEXANDER G. PADEREWSKI
December 20, 27, 2013 13-05993S

FIRST INSERTION

NOTICE OF SALE IN THE CIRCUIT COURT OF THE TWELFTH JUDICIAL CIRCUIT, IN AND FOR SARASOTA COUNTY, FLORIDA

CIVIL DIVISION
Case #: 2011-CA-010511-NC
DIVISION: C

EverBank, Successor by Merger to EverHome Mortgage Company
Plaintiff, vs.-
Patrick A. Yeamans; Unknown Parties in Possession #1
Defendant(s).

NOTICE IS HEREBY GIVEN pursuant to an Order dated November 22, 2013, entered in Civil Case No. 2011-CA-010511-NC of the Circuit Court of the 12th Judicial Circuit in and for Sarasota County, Florida, wherein EverBank, Successor by Merger to EverHome Mortgage Company, Plaintiff and Patrick A. Yeamans are defendant(s), I, Clerk of Court, Karen E. Rushing, will sell to the highest and best bidder for cash VIA THE INTERNET AT WWW.SARASOTA.REALFORECLOSE.COM, AT 9:00 A.M. on December 27, 2013, the following described property as set forth in said Final Judgment, to-wit:

LOT 13, BLOCK 899, 20TH ADDITION TO PORT CHARLOTTE SUBDIVISION, ACCORDING TO THE PLAT THEREOF, RECORDED IN PLAT BOOK 14, PAGE 8, 8A-8K, OF THE PUBLIC RECORDS OF SARASOTA COUNTY, FLORIDA.

ANY PERSON CLAIMING AN INTEREST IN THE SURPLUS FROM THE SALE, IF ANY, OTHER THAN THE PROPERTY OWNER AS OF THE DATE OF THE LIS PENDENS MUST FILE A CLAIM WITHIN 60 DAYS AFTER THE SALE.

If you are a person with a disability who needs any accommodation in order to participate in this proceeding, you are entitled, at no cost to you, to the provision of certain assistance. Please contact the Sarasota County Jury Office, P.O. Box 3079, Sarasota, Florida 34230-3079, (941)861-7400, at least seven (7) days before your scheduled court appearance, or immediately upon receiving this notification if the time before the scheduled appearance is less than seven (7) days; if you are hearing or voice impaired, call 711.

Submitted By:
ATTORNEY FOR PLAINTIFF:
SHAPIRO, FISHMAN & GACHÉ, LLP
2424 North Federal Highway, Suite 360
Boca Raton, Florida 33431
(561) 998-6700
(561) 998-6707
11-232572 FCO1 AMC
December 20, 27, 2013 13-05906S

FIRST INSERTION

NOTICE OF SALE IN THE CIRCUIT COURT OF THE TWELFTH JUDICIAL CIRCUIT, IN AND FOR SARASOTA COUNTY, FLORIDA

CASE NO: 2009 CA 015851 NC
BAC HOME LOANS SERVICING, LP,
Plaintiff, vs.
DEAN WILLIAMS,
Defendants.

NOTICE IS GIVEN that, in accordance with the Plaintiff's Final Judgment of Foreclosure entered on December 8, 2013 in the above-styled case, I will sell to the highest and best bidder for cash on January 10, 2014 at 9:00 A.M., at www.sarasota.realforeclose.com, the following described property:

LOT 533, OF DESOTO LAKES UNIT NO. 8 SUBDIVISION, ACCORDING TO THE PLAT THEREOF, AS RECORDED IN PLAT BOOK 9, AT PAGE 13, OF THE PUBLIC RECORDS OF SARASOTA COUNTY, FLORIDA.

Property Address: 4017 Prado Dr., Sarasota, FL 34235
ANY PERSON CLAIMING AN INTEREST IN THE SURPLUS FROM THE SALE, IF ANY, OTHER THAN THE PROPERTY OWNER AS OF THE DATE OF THE LIS PENDENS MUST FILE A CLAIM WITHIN 60 DAYS AFTER THE SALE.

If you are a person with a disability who needs any accommodation in order to participate in this proceeding, you are entitled, at no cost to you, to the provision of certain assistance. Please contact the Sarasota County Jury Office, P.O. Box 3079, Sarasota, Florida 34230-3079, (941)861-7400, at least seven (7) days before your scheduled court appearance, or immediately upon receiving this notification if the time before the scheduled appearance is less than seven (7) days; if you are hearing or voice impaired, call 711.

Dated: December 16, 2013.
Kelley L. Church, Esquire
Florida Bar No.: 100194
Quintairos, Prieto, Wood & Boyer, P.A.
255 South Orange Ave., Ste. 900
Orlando, FL 32801-3454
(407) 872-6011
(407)872-6012 Facsimile
E-mail: servicecopies@qpwbllaw.com
E-mail: kchurch@qpwbllaw.com
Matter # 66255
December 20, 27, 2013 13-05961S

FIRST INSERTION

NOTICE OF SALE IN THE CIRCUIT COURT OF THE TWELFTH JUDICIAL CIRCUIT IN AND FOR SARASOTA COUNTY, FLORIDA

CIVIL ACTION
CASE NO.: 58 2010 CA 002705 NC
NATIONSTAR MORTGAGE LLC,
Plaintiff vs.
ADAM PHILLIPS, et al.
Defendant(s)

Notice is hereby given that, pursuant to a Consent Uniform Final Judgment of Foreclosure, dated December 4, 2013, entered in Civil Case Number 58 2010 CA 002705 NC, in the Circuit Court for Sarasota County, Florida, wherein NATIONSTAR MORTGAGE LLC is the Plaintiff, and ADAM PHILLIPS, et al., are the Defendants, Sarasota County Clerk of Court will sell the property situated in Sarasota County, Florida, described as:

LOT 17, BLOCK 601, 18TH ADDITION TO PORT CHARLOTTE SUBDIVISION, A SUBDIVISION ACCORDING TO THE PLAT THEREOF AS RECORDED IN PLAT BOOK 14, PAGES 6, 6A-6V, OF THE PUBLIC RECORDS OF SARASOTA COUNTY, FLORIDA.

at public sale, to the highest and best bidder, for cash, at www.sarasota.realforeclose.com at 09:00 AM, on the 13th day of January, 2014. Any person claiming an interest in the surplus from the sale, if any, other than the property owner as of the date of the lis pendens must file a claim within 60 days after the sale.

If you are a person with a disability who needs any accommodation in order to participate in this proceeding, you are entitled, at no cost to you, to the provision of certain assistance. Please contact the Sarasota County Jury Office, P.O. Box 3079, Sarasota, Florida 34230-3079, (941)861-7400, at least seven (7) days before your scheduled court appearance, or immediately upon receiving this notification if the time before the scheduled appearance is less than seven (7) days; if you are hearing or voice impaired, call 711.

Dated: December 16, 2013
By: /s/ Brad Abramson
Brad Abramson, Esquire
(FBN 87554)

FLORIDA FORECLOSURE ATTORNEYS, PLLC
4855 Technology Way,
Suite 500
Boca Raton, FL 33431
(727) 446-4826
emailservice@ffapllc.com
Our File No: CA11-02838 /OA
December 20, 27, 2013 13-05953S

FIRST INSERTION

NOTICE OF SALE IN THE CIRCUIT COURT OF THE TWELFTH JUDICIAL CIRCUIT, IN AND FOR SARASOTA COUNTY, FLORIDA

CIVIL ACTION
CASE NO. 2013 CA 004965 NC
BUSEY BANK, an Illinois banking corporation,
Plaintiff, v.
ANTHONY DELOACH and LAURIE JO DELOACH, husband and wife; et al.
Defendant.

Notice is hereby given that, pursuant to Uniform Final Judgment of Mortgage Foreclosure entered in this cause in the Circuit Court of Sarasota County, Florida, the Clerk of the Circuit Court of Sarasota County, Florida will sell at public sale to the highest and best bidder for cash, online at: www.sarasota.realforeclose.com, on January 21, 2014 at 9:00 A.M. the property situated in Sarasota County, Florida described as follows:

Lots 28, 29, and 30, Tower Commerce Park, according to the map or plat thereof as recorded in Plat Book 33, Page 2, of the Public Records of Sarasota County, Florida.

Any person claiming an interest in the surplus from the sale, if any, other than the property owner as of the date of the Lis Pendens must file a claim within sixty (60) days after the sale.

If you are a person with a disability who needs any accommodation in order to participate in this proceeding, you are entitled, at no cost to you, to the provision of certain assistance. Please contact the Sarasota County Jury Office, P.O. Box 3079, Sarasota, Florida 34230-3079, (941)861-7400, at least seven (7) days before your scheduled court appearance, or immediately upon receiving this notification if the time before the scheduled appearance is less than seven (7) days; if you are hearing or voice impaired, call 711.

DATED this 17th day of December, 2013.

By: Luis E. Rivera II
Florida Bar No. 0013913
HENDERSON, FRANKLIN,
STARNES & HOLT, P.A.
Attorneys for Plaintiff
Post Office Box 280
Fort Myers, Florida 33902-0280
Telephone: 239.344.1323
Facsimile: 239.344.1533
December 20, 27, 2013 13-05992S

FIRST INSERTION

NOTICE OF FORECLOSURE SALE IN THE CIRCUIT COURT OF THE 12TH JUDICIAL CIRCUIT, IN AND FOR SARASOTA COUNTY, FLORIDA
GENERAL JURISDICTION DIVISION
CASE NO.: 2008 CA 014498 SC
COUNTRYWIDE HOME LOANS, INC.,
Plaintiff, vs.
DARREN J. NIGRO, __NIGRO, UNKNOWN SPOUSE OF DARREN J. NIGRO, IF MARRIED; DENISE ANN HAYWARD, ORAZIO NIGRO, PATRICIA G. NIGRO; JOHN DOE AND JANE DOE
Defendant(s).
NOTICE IS HEREBY GIVEN pursuant to a Uniform Final Judgment of Foreclosure Dated April 16, 2013 entered in Civil Case No. 2008 CA 014498 SC of the Circuit Court of the 12TH Judicial Circuit in and for Sarasota County, Sarasota County, Florida, wherein COUNTRYWIDE HOME LOANS, INC is the Plaintiff and DARREN J. NIGRO, ORAZIO NIGRO AND PATRICIA NIGRO, et al, are Defendants. The clerk shall sell to the highest and best bidder for cash at Sarasota County's Public Auction website: www.sarasota.realforeclose.com at 09:00 AM on January 14, 2014, the following described property as set forth in said Uniform Final Judgment of Foreclosure, to-wit:

LOT 11, IN BLOCK 182, OF SECOND ADDITION TO PORT CHARLOTTE SUBDIVISION, ACCORDING TO THE MAP OR PLAT THEREOF, AS RECORDED IN PLAT BOOK 11, AT PAGES 30, 30A THROUGH 30G, OF THE PUBLIC RECORDS OF SARASOTA COUNTY, FLORIDA

Any person claiming an interest in the surplus from the sale, if any, other than the property owner as of the date of the Lis Pendens, must file a claim within 60 days after the sale.

If you are a person with a disability who needs any accommodation in order to participate in this proceeding, you are entitled, at no cost to you, to the provision of certain assistance. Please contact the Sarasota County Jury Office, P.O. Box 3079, Sarasota, Florida 34230-3079, (941)861-7400, at least seven (7) days before your scheduled court appearance, or immediately upon receiving this notification if the time before the scheduled appearance is less than seven (7) days; if you are hearing or voice impaired, call 711.

Tania Marie Amar, Esq.
FRENKEL LAMBERT WEISS
WEISMAN & GORDON, LLP
One East Broward Blvd., Suite 1111
Fort Lauderdale, FL 33301
Tel: (954) 522-3233
Fax: (954) 200-7700
E-mail: tamar@flwlaw.com
FL Bar #: 84692
DESIGNATED PRIMARY E-MAIL FOR SERVICE PURSUANT TO FLA. R. JUD. ADMIN 2.516
flservice@flwlaw.com
04-062319-F00
December 20, 27, 2013 13-05919S

FIRST INSERTION

NOTICE OF ACTION IN THE CIRCUIT COURT OF THE TWELFTH JUDICIAL CIRCUIT IN AND FOR SARASOTA COUNTY, FLORIDA
CIVIL ACTION
CASE NO.: 58-2013-CA-001743 NC
WELLS FARGO BANK, N.A.,
Plaintiff, vs.
SHERYL L. FRALICK, et al,
Defendant(s).

To:
TED D. FRALICK
Last Known Address: 3922 Vana Drive, Sarasota, FL 34241
Current Address: Unknown
ANY AND ALL UNKNOWN PARTIES CLAIMING BY, THROUGH, UNDER, AND AGAINST THE HEREIN NAMED INDIVIDUAL DEFENDANT(S) WHO ARE NOT KNOWN TO BE DEAD OR ALIVE, WHETHER SAID UNKNOWN PARTIES MAY CLAIM AN INTEREST AS SPOUSES, HEIRS, DEVISEES, GRANTEES, OR OTHER CLAIMANTS
Last Known Address: Unknown
Current Address: Unknown

YOU ARE NOTIFIED that an action to foreclose a mortgage on the following property in Sarasota County, Florida:

LOT 1636, LAKE SARASOTA, UNIT NO. 18 ACCORDING TO THE PLAT THEREOF, AS RECORDED IN PLAT BOOK 9, PAGE 24, OF THE PUBLIC RECORDS OF SARASOTA COUNTY, FLORIDA.
A/K/A 3922 VANA DR SARASOTA FL 34241-5942

has been filed against you and you are required to serve a copy of your written defenses within 30 days after the first publication, if any, on Albertelli Law, Plaintiff's attorney, whose address is P.O. Box 23028, Tampa, FL 33623, and file the original with this Court either before January 20, 2014 service on Plaintiff's attorney, or immediately thereafter; otherwise, a default will be entered against you for the relief demanded in the Complaint or petition.

This notice shall be published once a week for two consecutive weeks in the Business Observer.

If you are a person with a disability who needs any accommodation in order to participate in this proceeding, you are entitled, at no cost to you, to the provision of certain assistance. Please contact the Sarasota County Jury Office, P.O. Box 3079, Sarasota, Florida 34230-3079, (941)861-7400, at least seven (7) days before your scheduled court appearance, or immediately upon receiving this notification if the time before the scheduled appearance is less than seven (7) days; if you are hearing or voice impaired, call 711.

WITNESS my hand and the seal of this court on the 9th day of December, 2013.

KAREN E. RUSHING, CLERK
Clerk of the Circuit Court
(SEAL) By: L. Szymanski
Deputy Clerk

Albertelli Law
P.O. Box 23028
Tampa, FL 33623
CR - 007501F01
December 20, 27, 2013 13-05934S

FIRST INSERTION

NOTICE OF RESCHEDULED SALE IN THE CIRCUIT COURT OF THE TWELFTH JUDICIAL CIRCUIT IN AND FOR SARASOTA COUNTY, FLORIDA
CIVIL ACTION
CASE NO.: 2008 CA 017877 NC
DIVISION: C

WACHOVIA MORTGAGE, FS.B.
F.K.A. WORLD SAVINGS BANK,
Plaintiff, vs.
KATHLEEN M. DEFREEST, et al,
Defendant(s).

NOTICE IS HEREBY GIVEN Pursuant to an Order Rescheduling Foreclosure Sale dated December 9, 2013, and entered in Case No. 2008 CA 017877 NC of the Circuit Court of the Twelfth Judicial Circuit in and for Sarasota County, Florida in which Wachovia Mortgage, FS.B. f.k.a. World Savings Bank, is the Plaintiff and Kathleen M. DeFreest, Phillip DeFreest, Swifton Villas Condominium Association Inc., Tenant #1 n/k/a Arthur Killingbeck, are defendants, the Sarasota County Clerk of the Circuit Court will sell to the highest and best bidder for cash in/on the Internet: www.sarasota.realforeclose.com, Sarasota County, Florida at 9:00am on the 24th day of January, 2014, the following described property as set forth in said Final Judgment of Foreclosure:

VILLA NO. 104, SWIFTON VILLAS, SECTION B, A CONDOMINIUM, ACCORDING TO THE DECLARATION OF CONDOMINIUM RECORDED IN OFFICIAL RECORDS BOOK 884, PAGES 161 THROUGH 175, INCLUSIVE, AS AMENDED, AND AS PER PLAT THEREOF RECORDED IN CONDOMINIUM BOOK 4, PAGE 34, AS AMENDED, OF THE PUBLIC RECORDS OF SARASOTA COUNTY, FLORIDA. TOGETHER WITH AN UNDIVIDED INTEREST IN THE COMMON ELEMENTS APPURTENANT THERETO

A/K/A 2806 SWIFTON DRIVE,
#104, SARASOTA, FL 34231

Any person claiming an interest in the surplus from the sale, if any, other than the property owner as of the date of the Lis Pendens must file a claim within 60 days after the sale.

If you are a person with a disability who needs any accommodation in order to participate in this proceeding, you are entitled, at no cost to you, to the provision of certain assistance. Please contact the Sarasota County Jury Office, P.O. Box 3079, Sarasota, Florida 34230-3079, (941)861-7400, at least seven (7) days before your scheduled court appearance, or immediately upon receiving this notification if the time before the scheduled appearance is less than seven (7) days; if you are hearing or voice impaired, call 711.

Albertelli Law
Attorney for Plaintiff
P.O. Box 23028
Tampa, FL 33623
(813) 221-4743
(813) 221-9171 facsimile
eService: servealaw@albertellilaw.com
08-11481
December 20, 27, 2013 13-05968S

FIRST INSERTION

NOTICE OF RESCHEDULED SALE IN THE CIRCUIT COURT OF THE TWELFTH JUDICIAL CIRCUIT IN AND FOR SARASOTA COUNTY, FLORIDA
CIVIL ACTION
CASE NO.: 2009 CA 010248 NC
U.S. BANK NATIONAL ASSOCIATION, AS TRUSTEE FOR THE BENEFIT OF BARBORVIEW 2005-08 TRUST FUND,
Plaintiff, vs.
MARGARITA H. QUEVEDO, et al,
Defendant(s).

NOTICE IS HEREBY GIVEN Pursuant to an Order Rescheduling Foreclosure Sale dated on or about November 27, 2013, and entered in Case No. 2009 CA 010248 NC of the Circuit Court of the Twelfth Judicial Circuit in and for Sarasota County, Florida in which U.S. Bank National Association, as Trustee For the Benefit of Barborview 2005-08 Trust Fund, is the Plaintiff and Felix P. Quevedo, Margarita H. Quevedo, Mortgage Electronic Registration Services, Inc., acting solely as nominee for Countrywide Bank, a Division of Treasury Bank, N.A., Serenade on Palmer Ranch Condominium Association, Inc., are defendants, the Sarasota County Clerk of the Circuit Court will sell to the highest and best bidder for cash in/on the Internet: www.sarasota.realforeclose.com, Sarasota County, Florida at 9:00am on the 27th day of January, 2014, the following described property as set forth in said Final Judgment of Foreclosure:

UNIT 207, IN BUILDING 7, OF SERENADE ON PALMER RANCH CONDOMINIUM, ACCORDING TO THE DECLARATION OF CONDOMINIUM RECORDED IN OFFICIAL RECORDS INSTRUMENT NUMBER 2005045834 AND AMENDMENTS THERETO, OF THE PUBLIC RECORDS OF SARASOTA COUNTY.

A/K/A 5174 NORTH RIDGE ROAD UNIT 7-2, SARASOTA, FL 34238

Any person claiming an interest in the surplus from the sale, if any, other than the property owner as of the date of the Lis Pendens must file a claim within 60 days after the sale.

If you are a person with a disability who needs any accommodation in order to participate in this proceeding, you are entitled, at no cost to you, to the provision of certain assistance. Please contact the Sarasota County Jury Office, P.O. Box 3079, Sarasota, Florida 34230-3079, (941)861-7400, at least seven (7) days before your scheduled court appearance, or immediately upon receiving this notification if the time before the scheduled appearance is less than seven (7) days; if you are hearing or voice impaired, call 711.

Albertelli Law
Attorney for Plaintiff
P.O. Box 23028
Tampa, FL 33623
(813) 221-4743
(813) 221-9171 facsimile
eService: servealaw@albertellilaw.com
BM - 10-44146
December 20, 27, 2013 13-05984S

FIRST INSERTION

NOTICE OF RESCHEDULED SALE IN THE CIRCUIT COURT OF THE TWELFTH JUDICIAL CIRCUIT IN AND FOR SARASOTA COUNTY, FLORIDA
CIVIL ACTION
CASE NO.: 2011 CA 008539 NC
WILMINGTON TRUST COMPANY, AS SUCCESSOR TRUSTEE TO BANK OF AMERICA NATIONAL ASSOCIATION AS SUCCESSOR BY MERGER TO LASALLE BANK NATIONAL ASSOCIATION AS TRUSTEE OF LXS 2007-6 TRUST FUND,
Plaintiff, vs.
APRIL D. MANSUR, et al,
Defendant(s).

NOTICE IS HEREBY GIVEN Pursuant to an Order Rescheduling Foreclosure Sale dated on or about November 22, 2013, and entered in Case No. 2011 CA 008539 NC of the Circuit Court of the Twelfth Judicial Circuit in and for Sarasota County, Florida in which Wilmington Trust Company, as successor trustee to Bank of America National Association as successor by merger to LaSalle Bank National Association as trustee of LXS 2007-6 Trust Fund, is the Plaintiff and April D. Mansur, Mortgage Electronic Registration Systems, Inc., acting solely as nominee for Optimum Financial Services, LLC, are defendants, the Sarasota County Clerk of the Circuit Court will sell to the highest and best bidder for cash in/on the Internet: www.sarasota.realforeclose.com, Sarasota County, Florida at 9:00am on the 24th day of January, 2014, the following described property as set forth in said Final Judgment of Foreclosure:

LOT 40, BLOCK 1442, TWENTY-NINTH ADDITION TO PORT CHARLOTTE SUBDIVISION, ACCORDING TO THE PLAT THEREOF AS RECORDED IN PLAT BOOK 15, PAGES 13, 13A THROUGH 13N, INCLUSIVE, OF THE PUBLIC RECORDS OF SARASOTA COUNTY, FLORIDA.

A/K/A 4415 BALSEY ST, NORTH PORT, FL 34286

Any person claiming an interest in the surplus from the sale, if any, other than the property owner as of the date of the Lis Pendens must file a claim within 60 days after the sale.

If you are a person with a disability who needs any accommodation in order to participate in this proceeding, you are entitled, at no cost to you, to the provision of certain assistance. Please contact the Sarasota County Jury Office, P.O. Box 3079, Sarasota, Florida 34230-3079, (941)861-7400, at least seven (7) days before your scheduled court appearance, or immediately upon receiving this notification if the time before the scheduled appearance is less than seven (7) days; if you are hearing or voice impaired, call 711.

Albertelli Law
Attorney for Plaintiff
P.O. Box 23028
Tampa, FL 33623
(813) 221-4743
(813) 221-9171 facsimile
eService: servealaw@albertellilaw.com
BM - 11-78661
December 20, 27, 2013 13-05969S

FIRST INSERTION

NOTICE OF FORECLOSURE SALE PURSUANT TO CHAPTER 45 IN THE CIRCUIT COURT OF THE TWELFTH JUDICIAL CIRCUIT IN AND FOR SARASOTA COUNTY, FLORIDA

CASE NO. 582009CA000461NC
CITIBANK N.A. AS TRUSTEE FOR BSALTA 20
Plaintiff(s),
vs.
MARC PELLETZ; et al,
Defendant(s).

NOTICE IS HEREBY GIVEN that Sale will be made pursuant to an Order or Final Summary Judgment. Final Judgment was awarded on August 30, 2013 in Civil Case No.: 582009CA000461NC, of the Circuit Court of the TWELFTH Judicial Circuit in and for SARASOTA County, Florida, wherein, CITIBANK N.A. AS TRUSTEE FOR BSALTA 20 is the Plaintiff, and, MARC PELLETZ; UNKNOWN SPOUSE OF MARC PELLETZ; UNKNOWN TENANT N/K/A SUE HAMILTON; AND UNKNOWN TENANT(S) IN POSSESSION are Defendants.

The clerk of the court, Karen E. Rushing, will sell to the highest bidder for cash online at www.sarasota.realforeclose.com at 9:00 AM on January 7, 2014, the following described real property as set forth in said Final Summary Judgment, to wit:

THE NORTH 40 FEET OF LOT 108 TOGETHER WITH THE SOUTH 40 FEET OF LOT 109, OAK SHORES FIRST ADDITION, ACCORDING TO THE PLAT THEREOF AS RECORDED IN PLAT BOOK 8, PAGE 29 AND 29A, OF THE PUBLIC RECORDS OF SARASOTA COUNTY, FLORIDA

PROPERTY ADDRESS: 810 LOCKLEAR AVENUE, SARASOTA, FL 34237

ANY PERSON CLAIMING AN INTEREST IN THE SURPLUS FUNDS FROM THE SALE, IF ANY, OTHER THAN THE PROPERTY OWNER AS OF THE DATE OF THE LIS PENDENS MUST FILE A CLAIM WITHIN 60 DAYS AFTER THE SALE.

If you are a person with a disability who needs any accommodation in order to participate in this proceeding, you are entitled, at no cost to you, to the provision of certain assistance. Please contact the Sarasota County Jury Office, P.O. Box 3079, Sarasota, Florida 34230-3079, (941)861-7400, at least seven (7) days before your scheduled court appearance, or immediately upon receiving this notification if the time before the scheduled appearance is less than seven (7) days; if you are hearing or voice impaired, call 711.

Dated this 17 day of December, 2013.

BY: Sarah M. Barbaccia
FBN 30043

Aldridge Connors, LLP
Attorney for Plaintiff(s)
1615 South Congress Avenue,
Suite 200
Delray Beach, FL 33445
Phone: 561.392.6391
Fax: 561.392.6965
Primary E-Mail:
ServiceMail@aqlawllp.com
1271-582B
December 20, 27, 2013 13-05985S

FIRST INSERTION

NOTICE OF SALE PURSUANT TO CHAPTER 45 IN THE CIRCUIT COURT OF THE TWELFTH JUDICIAL CIRCUIT IN AND FOR SARASOTA COUNTY, FLORIDA

CIVIL DIVISION
CASE NO. 2012 CA 002971 NC
THE BANK OF NEW YORK MELLON FKA THE BANK OF NEW YORK AS SUCCESSOR TRUSTEE TO JPMORGAN CHASE BANK, N.A. AS TRUSTEE FOR THE HOLDERS OF SAMI II TRUST 2006-AR3, MORTGAGE PASS-THROUGH CERTIFICATES, SERIES 2006-AR3
Plaintiff, vs.
Beth Moran A/K/A Beth M. Moran A/K/A Elizabeth M. Moran, et al,
Defendants/

NOTICE IS HEREBY GIVEN pursuant to an Order or Final Judgment of Foreclosure dated November 19, 2012, and entered in Case No. 2012 CA 002971 NC of the Circuit Court of the TWELFTH Judicial Circuit in and for Sarasota County, Florida, wherein THE BANK OF NEW YORK MELLON FKA THE BANK OF NEW YORK AS SUCCESSOR TRUSTEE TO JPMORGAN CHASE BANK, N.A. AS TRUSTEE FOR THE HOLDERS OF SAMI II TRUST 2006-AR3, MORTGAGE PASS-THROUGH CERTIFICATES, SERIES 2006-AR3 is the Plaintiff and Beth Moran A/K/A Beth M. Moran A/K/A Elizabeth M. Moran, Suntrust Bank, The Independent Savings Plan Company D/B/A Ispc, the Defendants, I will sell to the highest and best bidder for cash www.sarasota.realforeclose.com, the Clerk's website for on-line auctions at 9:00 a.m. on January 17, 2014, the following described property as set forth in said Order of Final Judgment, to wit:

The South 36 Feet Of Lot 2, Block

A, And The North 54 Feet Of Lot 3, Block A, Of Survey Of Lots 1 And 2, Indian Beach Subdivision, According To The Plat Thereof, Recorded In Deed Book 307, Page 373, Of The Public Records Of Sarasota County, Florida.

IF YOU ARE A PERSON CLAIMING A RIGHT TO FUNDS REMAINING AFTER THE SALE, YOU MUST FILE A CLAIM WITH THE CLERK OF COURT NO LATER THAN 60 DAYS AFTER THE SALE. IF YOU FAIL TO FILE A CLAIM, YOU WILL NOT BE ENTITLED TO ANY REMAINING FUNDS. AFTER 60 DAYS, ONLY THE OWNER OF RECORD AS OF THE DATE OF THE LIS PENDENS MAY CLAIM THE SURPLUS.

If you are a person with a disability who needs any accommodation in order to participate in this proceeding, you are entitled, at no cost to you, to the provision of certain assistance. Please contact the Sarasota County Jury Office, P.O. Box 3079, Sarasota, Florida 34230-3079, (941)861-7400, at least seven (7) days before your scheduled court appearance, or immediately upon receiving this notification if the time before the scheduled appearance is less than seven (7) days; if you are hearing or voice impaired, call 711.

DATED AT SARASOTA County, Florida, this 13th day of Dec, 2013.

By: Kalei McElroy Blair, Esq./
Florida Bar #44613
GILBERT GARCIA GROUP, P.A.,
Attorney for Plaintiff
2005 Pan Am Circle,
Suite 110
Tampa, FL 33607
Phone: (813) 443-5087
Fax: (813) 443-5089
emailservice@gilbertgroup.com
720241.1122/nls
December 20, 27, 2013 13-05941S

FIRST INSERTION

NOTICE OF SALE IN THE CIRCUIT COURT OF THE TWELFTH JUDICIAL CIRCUIT IN AND FOR SARASOTA COUNTY, FLORIDA

CASE NO. 2010 CA 012149 NC
US BANK NATIONAL ASSOCIATION, AS TRUSTEE FOR CREDIT SUISSE FIRST BOSTON MORTGAGE SECURITIES CORP., CSFB MORTGAGE PASS-THROUGH CERTIFICATES, SERIES 2005-8
Plaintiff, v.
LOIS E. TROIANO; UNKNOWN SPOUSE OF LOIS E. TROIANO; UNKNOWN TENANT 1; UNKNOWN TENANT 2; AND ALL UNKNOWN PARTIES CLAIMING BY, THROUGH, UNDER OR AGAINST THE ABOVE NAMED DEFENDANT(S), WHO (IS/ ARE) NOT KNOWN TO BE DEAD OR ALIVE, WHETHER SAID UNKNOWN PARTIES CLAIM AS HEIRS, DEVISEES, GRANTEES, ASSIGNEES, LIENORS, CREDITORS, TRUSTEES, SPOUSES, OR OTHER CLAIMANTS; WELLS FARGO BANK, N.A., SUCCESSOR BY MERGER TO WACHOVIA BANK, NATIONAL ASSOCIATION; WOODMERE LAKES HOMEOWNER'S ASSOCIATION, INC.
Defendants.

Notice is hereby given that, pursuant to the Summary Final Judgment of Foreclosure entered on December 06, 2013, in this cause, in the Circuit Court of Sarasota County, Florida, the clerk shall sell the property situated in Sarasota County, Florida, described as:

LOT 39, WOODMERE LAKES, UNIT 1, ACCORDING TO THE PLAT THEREOF RECORDED

IN PLAT BOOK 37, PAGE 28, OF THE PUBLIC RECORDS OF SARASOTA COUNTY, FLORIDA.

a/k/a 4343 MANFIELD DRIVE, VENICE, FL 34293
at public sale, to the highest and best bidder, for cash, online at www.sarasota.realforeclose.com, on January 10, 2014 beginning at 09:00 AM.

If you are a person claiming a right to funds remaining after the sale, you must file a claim with the clerk no later than 60 days after the sale. If you fail to file a claim you will not be entitled to any remaining funds.

If you are a person with a disability who needs any accommodation in order to participate in this proceeding, you are entitled, at no cost to you, to the provision of certain assistance. Please contact the Sarasota County Jury Office, P.O. Box 3079, Sarasota, Florida 34230-3079, (941)861-7400, at least seven (7) days before your scheduled court appearance, or immediately upon receiving this notification if the time before the scheduled appearance is less than seven (7) days; if you are hearing or voice impaired, call 711.

Dated at St. Petersburg, Florida, this 13th day of December 2013.

By: /s/ Angela L. Leiner, Esquire
Angela L. Leiner
FBN#85112

Douglas C. Zahm, P.A.
Designated Email Address:
efiling@dczahm.com
12425 28th Street North,
Suite 200
St. Petersburg, FL 33716
Telephone No. (727) 536-4911
Attorney for the Plaintiff
885100986
December 20, 27, 2013 13-05946S

FIRST INSERTION

NOTICE OF FORECLOSURE SALE IN THE CIRCUIT COURT OF THE TWELFTH JUDICIAL CIRCUIT, IN AND FOR SARASOTA COUNTY, FLORIDA
CIVIL DIVISION

CASE NO.: 2013 CA 000399 NC
JPMORGAN CHASE BANK, NATIONAL ASSOCIATION, SUCCESSOR IN INTEREST BY PURCHASE FROM THE FDIC AS RECEIVER OF WASHINGTON MUTUAL BANK F/K/A WASHINGTON MUTUAL BANK, FA
Plaintiff, vs.
ST. PAUL'S SCHOOL, et al
Defendants.

NOTICE IS HEREBY GIVEN pursuant to a Summary Final Judgment of foreclosure dated November 19, 2013, and entered in Case No. 2013 CA 000399 NC of the Circuit Court of the TWELFTH Judicial Circuit in and for SARASOTA COUNTY, Florida, wherein JPMORGAN CHASE BANK, NATIONAL ASSOCIATION, SUCCESSOR IN INTEREST BY PURCHASE FROM THE FDIC AS RECEIVER OF WASHINGTON MUTUAL BANK F/K/A WASHINGTON MUTUAL BANK, FA, is Plaintiff, and ST. PAUL'S SCHOOL, et al are Defendants, the clerk will sell to the highest and best bidder for cash, beginning at 09:00 AM at www.sarasota.realforeclose.com, in accordance with Chapter 45, Florida Statutes, on the 21 day of January, 2014, the following described property as set forth in said Summary Final Judgment, to wit:

LOT 11, BLOCK 8, GOLDEN BEACH, UNIT NO. 2, AS PER PLAT THEREOF RECORDED IN PLAT BOOK 7, PAGES 96

AND 96A, OF THE PUBLIC RECORDS OF SARASOTA COUNTY, FLORIDA.

SUBJECT TO covenants, restrictions, easements of record and taxes for the current year.

Parcel Identification Number: 0177-09-0037

Any person claiming an interest in the surplus funds from the sale, if any, other than the property owner as of the date of the lis pendens must file a claim within 60 days after the sale.

If you are a person with a disability who needs any accommodation in order to participate in this proceeding, you are entitled, at no cost to you, to the provision of certain assistance. Please contact the Sarasota County Jury Office, P.O. Box 3079, Sarasota, Florida 34230-3079, (941)861-7400, at least seven (7) days before your scheduled court appearance, or immediately upon receiving this notification if the time before the scheduled appearance is less than seven (7) days; if you are hearing or voice impaired, call 711.

Dated: December 13, 2013

By: /s/ Heather J. Koch
Phelan Hallinan, PLC
Heather J. Koch, Esq.,
Florida Bar No. 89107
Emilio R. Lenzi, Esq.,
Florida Bar No. 0668273

Phelan Hallinan, PLC
Attorneys for Plaintiff
2727 West Cypress Creek Road
Ft. Lauderdale, FL 33309
Tel: 954-462-7000
Fax: 954-462-7001
Service by email:
FL.Service@PhelanHallinan.com
December 20, 27, 2013 13-05922S

FIRST INSERTION

NOTICE OF FORECLOSURE SALE IN THE CIRCUIT COURT OF THE TWELFTH JUDICIAL CIRCUIT IN AND FOR SARASOTA COUNTY, FLORIDA
CIVIL ACTION
CASE NO.: 58 2012 CA 008120 NC DIVISION: C
BANK OF AMERICA, N.A., SUCCESSOR BY MERGER TO BAC HOME LOANS SERVICING, LP, FKA COUNTRYWIDE HOME LOANS SERVICING LP, Plaintiff, vs.
THE UNKNOWN HEIRS, DEVISEES, GRANTEEES, ASSIGNEES, LIENORS, CREDITORS, TRUSTEES, OR OTHER CLAIMANTS CLAIMING BY, THROUGH, UNDER, OR AGAINST ALAN P. HUNT, DECEASED, et al, Defendant(s).
NOTICE IS HEREBY GIVEN pursuant to a Final Judgment of Mortgage Foreclosure dated December 16, 2013 and entered in Case No. 58 2012 CA 008120 NC of the Circuit Court of the TWELFTH Judicial Circuit in and for SARASOTA County, Florida wherein NATIONSTAR MORTGAGE LLC, 1 Plaintiff name has changed pursuant to order previously entered, is the Plaintiff and THE UNKNOWN HEIRS, DEVISEES, GRANTEEES, ASSIGNEES, LIENORS, CREDITORS, TRUSTEES, OR OTHER CLAIMANTS CLAIMING BY, THROUGH, UNDER, OR AGAINST ALAN P. HUNT, DECEASED; HOWARD PRI HUNT, JR. A/K/A HOWARD P. HUNT, JR. A/K/A HOWARD P. HUNT A/K/A HOWARD HUNT A/K/A SONNY HUNT AS HEIR OF THE ESTATE OF ALAN P. HUNT A/K/A ALAN PRICE HUNT A/K/A ALAN PRI HUNT A/K/A ALAN HUNT, DECEASED; JPMORGAN CHASE BANK, N.A.; HERON

SHORES HOMEOWNERS, INC.; GE CAPITAL RETAIL BANK; COMMONWEALTH CREDIT UNION, INC.; FARMERS NATIONAL BANK OF DANVILLE; are the Defendants, The Clerk will sell to the highest and best bidder for cash at WWW.SARASOTA.REALFORECLOSE.COM at 9:00AM, on the 24th day of January, 2014, the following described property as set forth in said Final Judgment:
LOT 34, HERON SHORES, ACCORDING TO THE PLAT THEREOF RECORDED IN PLAT BOOK 30, PAGE 21, OF THE PUBLIC RECORDS OF SARASOTA COUNTY, FLORIDA.

A/K/A 3126 HERON SHORES DRIVE, VENICE, FL 34293
Any person claiming an interest in the surplus from the sale, if any, other than the property owner as of the date of the Lis Pendens must file a claim within sixty (60) days after the sale.
If you are a person with a disability who needs any accommodation in order to participate in this proceeding, you are entitled, at no cost to you, to the provision of certain assistance. Please contact the Sarasota County Jury Office, P.O. Box 3079, Sarasota, Florida 34230-3079, (941)861-7400, at least seven (7) days before your scheduled court appearance, or immediately upon receiving this notification if the time before the scheduled appearance is less than seven (7) days; if you are hearing or voice impaired, call 711.
By: Lisa M. Lewis
Florida Bar No. 0086178
Ronald R Wolfe & Associates, P.L.
P.O. Box 25018
Tampa, Florida 33622-5018
(813) 251-4766
(813) 251-1541 Fax
F12001627
December 20, 27, 2013 13-05974S

FIRST INSERTION

NOTICE OF FORECLOSURE SALE IN THE CIRCUIT COURT OF THE 12th JUDICIAL CIRCUIT IN AND FOR SARASOTA COUNTY, FLORIDA
CASE NO.: 2010 CA 003777 NC DIV. A
WELLS FARGO BANK, N.A., ALSO KNOWN AS WACHOVIA MORTGAGE, A DIVISION OF WELLS FARGO BANK, N.A., FORMERLY KNOWN AS WACHOVIA MORTGAGE, FSB, FORMERLY KNOWN AS WORLD SAVINGS BANK, FSB Plaintiff, vs.
PAMELA HORROW, REGIONS BANK, Defendants.
NOTICE IS HEREBY GIVEN pursuant to a Summary Final Judgment of Foreclosure dated December 16, 2013, and entered in Case No. 2010 CA 003777 NC Div. A of the Circuit Court of the 12th Judicial Circuit, in and for SARASOTA County, Florida, where in WELLS FARGO BANK, N.A., ALSO KNOWN AS WACHOVIA MORTGAGE, A DIVISION OF WELLS FARGO BANK, N.A., FORMERLY KNOWN AS WACHOVIA MORTGAGE, FSB, FORMERLY KNOWN AS WORLD SAVINGS BANK, FSB, is the Plaintiff and PAMELA HORROW, REGIONS BANK, are the Defendants, the Clerk of Court shall offer for sale to the highest bidder for cash on January 21, 2014, at 9:00 A.M., at www.sarasota.realforeclose.com, the following described property as set forth in said Summary Final Judgment lying and being situate in SARASOTA County, Florida, to wit:
Lot 10, and the East 1/2 of Lot 8, Block 0, Cottage in the Pines, according to the map or plat thereof, as recorded in Plat Book 5, Page

24, of the Public Records of Sarasota County, Florida.
ANY PERSON CLAIMING AN INTEREST IN THE SURPLUS FROM THE SALE, IF ANY, OTHER THAN THE PROPERTY OWNER AS OF THE DATE OF THE LIS PENDENS MUST FILE A CLAIM WITHIN 60 DAYS AFTER THE SALE. THE CLERK SHALL RECEIVE A SERVICE CHARGE OF UP TO \$70 FOR SERVICES IN MAKING, RECORDING, AND CERTIFYING THE SALE AND TITLE THAT SHALL BE ASSESSED AS COSTS. THE COURT, IN ITS DISCRETION, MAY ENLARGE THE TIME OF THE SALE. NOTICE OF THE CHANGED TIME OF SALE SHALL BE PUBLISHED AS PROVIDED HEREIN.
If you are a person with a disability who needs any accommodation in order to participate in this proceeding, you are entitled, at no cost to you, to the provision of certain assistance. Please contact the Sarasota County Jury Office, P.O. Box 3079, Sarasota, Florida 34230-3079, (941)861-7400, at least seven (7) days before your scheduled court appearance, or immediately upon receiving this notification if the time before the scheduled appearance is less than seven (7) days; if you are hearing or voice impaired, call 711.
DATED this 16th day of December, 2013.
By: Arnold M. Straus, Jr.
Arnold M. Straus, Jr.
Fla Bar 275328
STRAUS & EISLER, P.A.
Attorneys for Plaintiff
10081 Pines Blvd., Suite C
Pembroke Pines, FL 33024
954-431-2000
Service.pines@strausesler.com
December 20, 27, 2013 13-05957S

FIRST INSERTION

RE-NOTICE OF FORECLOSURE SALE IN THE CIRCUIT COURT OF THE 12TH JUDICIAL CIRCUIT, IN AND FOR SARASOTA COUNTY, FLORIDA
CIVIL DIVISION:
CASE NO.: 2012 CA 009076 NC
JPMORGAN CHASE BANK, NATIONAL ASSOCIATION, SUCCESSOR IN INTEREST BY PURCHASE FROM THE FDIC AS RECEIVER OF WASHINGTON MUTUAL BANK F/K/A WASHINGTON MUTUAL BANK, FA Plaintiff, vs.
JOHN A. BENCIE; MARA VILLA II CONDOMINIUM ASSOCIATION, INC.; MV MANAGEMENT ASSOCIATION, INC.; PALMER RANCH MASTER PROPERTY OWNERS ASSOCIATION, INC.; PRESTANCIA COMMUNITY ASSOCIATION, INC.; USAA FEDERAL SAVINGS BANK; UNKNOWN TENANT IN POSSESSION OF THE SUBJECT

PROPERTY, Defendants.
NOTICE IS HEREBY GIVEN pursuant to an Order Resetting Foreclosure Sale dated the 10th day of December, 2013, and entered in Case No. 2012 CA 009076 NC, of the Circuit Court of the 12TH Judicial Circuit in and for Sarasota County, Florida, wherein JPMORGAN CHASE BANK, NATIONAL ASSOCIATION, SUCCESSOR IN INTEREST BY PURCHASE FROM THE FDIC AS RECEIVER OF WASHINGTON MUTUAL BANK F/K/A WASHINGTON MUTUAL BANK, FA is the Plaintiff and JOHN A. BENCIE; MARA VILLA II CONDOMINIUM ASSOCIATION, INC.; MV MANAGEMENT ASSOCIATION, INC.; PALMER RANCH MASTER PROPERTY OWNERS ASSOCIATION, INC.; PRESTANCIA COMMUNITY ASSOCIATION, INC.; USAA FEDERAL SAVINGS BANK; UNKNOWN TENANT IN POSSESSION OF THE SUBJECT PROPERTY are defendants. The Clerk of this Court shall sell to the highest and best bidder for cash electronically at www.sarasota.

realforeclose.com at 9:00 AM on the 14th day of January, 2014, the following described property as set forth in said Final Judgment, to wit:
UNIT 75, MARA VILLA, A CONDOMINIUM, ACCORDING TO THE DECLARATION OF CONDOMINIUM RECORDED IN OFFICIAL RECORDS BOOK 2258, PAGE 720, AND AS PER PLAT THEREOF, RECORDED IN CONDOMINIUM BOOK 29, PAGE 12, OF THE PUBLIC RECORDS OF SARASOTA COUNTY, FLORIDA, TOGETHER WITH COVERED PARKING SPACE AND STORAGE AREA DESIGNATED AS L.C.E. NUMBER B-1
ANY PERSON CLAIMING AN INTEREST IN THE SURPLUS FROM THE SALE, IF ANY, OTHER THAN THE PROPERTY OWNER AS OF THE DATE OF THE LIS PENDENS MUST FILE A CLAIM WITHIN 60 DAYS AFTER THE SALE.
If you are a person with a disability who needs any accommodation in order to participate in this

proceeding, you are entitled, at no cost to you, to the provision of certain assistance. Please contact the Sarasota County Jury Office, P.O. Box 3079, Sarasota, Florida 34230-3079, (941)861-7400, at least seven (7) days before your scheduled court appearance, or immediately upon receiving this notification if the time before the scheduled appearance is less than seven (7) days; if you are hearing or voice impaired, call 711.
DATED this 17th day of December, 2013.
By: Carri L. Pereyra
Bar #17441
Choice Legal Group, P.A.
1800 NW 49th Street,
Suite 120
Fort Lauderdale, Florida 33309
Telephone: (954) 453-0365
Facsimile: (954) 771-6052
Toll Free: 1-800-441-2438
DESIGNATED PRIMARY E-MAIL FOR SERVICE PURSUANT TO FLA R. JUD. ADMIN 2.516
eservice@clelegalgroup.com
11-21765
December 20, 27, 2013 13-06002S

FIRST INSERTION

NOTICE OF SALE IN THE CIRCUIT COURT OF THE TWELFTH JUDICIAL CIRCUIT OF THE STATE OF FLORIDA, IN AND FOR SARASOTA COUNTY CIVIL DIVISION
CASE NO. 58-2009-CA-003529-XXA-NC
U.S. BANK NATIONAL ASSOCIATION ND, Plaintiff, vs.
RONALD L. SPENCE; UNKNOWN SPOUSE OF RONALD L. SPENCE; IF LIVING, INCLUDING ANY UNKNOWN SPOUSE OF SAID DEFENDANT(S), IF REMARRIED, AND IF DECEASED, THE RESPECTIVE UNKNOWN HEIRS, DEVISEES, GRANTEEES, ASSIGNEES, CREDITORS, LIENORS, AND TRUSTEES, AND ALL OTHER PERSONS CLAIMING BY, THROUGH, UNDER OR AGAINST THE NAMED DEFENDANT(S); LAS PALMAS OF SARASOTA CONDOMINIUM ASSOCIATION, INC.; WHETHER DISSOLVED OR PRESENTLY EXISTING, TOGETHER WITH ANY GRANTEEES, ASSIGNEES, CREDITORS, LIENORS, OR TRUSTEES OF SAID DEFENDANT(S) AND ALL OTHER PERSONS CLAIMING BY, THROUGH, UNDER, OR AGAINST DEFENDANT(S); UNKNOWN TENANT #1; UNKNOWN TENANT #2; Defendant(s)
Notice is hereby given that, pursuant to a Final Summary Judgment of Foreclosure entered on 06/11/2012 in the above styled cause, in the Circuit Court of Sarasota County, Florida, the office of Karen E. Rushing clerk of the circuit court will sell the property situate in Sarasota County, Florida, described as:
CONDOMINIUM UNIT NO.

5-115, LAS PALMAS OF SARASOTA, A LUXURY CONDOMINIUM, ACCORDING TO THE DECLARATION THEREOF, AS RECORDED IN INSTRUMENT 2004247846, AS AMENDED IN INSTRUMENT NO. 2004247847, BOTH OF THE PUBLIC RECORDS OF SARASOTA COUNTY, FLORIDA.
at public sale, to the highest and best bidder, for cash, www.sarasota.realforeclose.com at 9:00 o'clock, A.M., on January 13, 2014
Any person claiming an interest in the surplus from the sale, if any, other than the property owner as of the date of the lis pendens, must file a claim within 60 days after the sale.
If you are a person with a disability who needs any accommodation in order to participate in this proceeding, you are entitled, at no cost to you, to the provision of certain assistance. Please contact the Sarasota County Jury Office, P.O. Box 3079, Sarasota, Florida 34230-3079, (941)861-7400, at least seven (7) days before your scheduled court appearance, or immediately upon receiving this notification if the time before the scheduled appearance is less than seven (7) days; if you are hearing or voice impaired, call 711.
ATTORNEY FOR PLAINTIFF
By Josh D. Donnelly
Florida Bar #64788
Date: 12/17/2013
THIS INSTRUMENT PREPARED BY:
Law Offices Of Daniel C. Consuegra
9204 King Palm Drive
Tampa, FL 33619-1328
Phone: 813-915-8660
Attorneys for Plaintiff
35498
December 20, 27, 2013 13-05989S

FIRST INSERTION

NOTICE OF SALE PURSUANT TO CHAPTER 45 IN THE CIRCUIT COURT OF THE TWELFTH JUDICIAL CIRCUIT IN AND FOR SARASOTA COUNTY, FLORIDA
CIVIL ACTION
CASE NO.: 2008 CA 017255 NC DIVISION: A
BAC HOME LOANS SERVICING, LP, Plaintiff, vs.
MITCHELL ROBERTS, et al, Defendant(s).
NOTICE IS HEREBY GIVEN Pursuant to a Final Judgment of Foreclosure dated September 24, 2013, and entered in Case No. 2008 CA 017255 NC of the Circuit Court of the Twelfth Judicial Circuit in and for Sarasota County, Florida in which BAC HOME LOANS SERVICING, LP, is the Plaintiff and Mitchell Roberts, Jane Doe as in Possession of the Subject Property NKA Victoria Vancleave, John Doe as in Possession of the Subject Property NKA Rayan Vancleave, Riverside Bank of the Gulf Coast, The Village at BEEKMAN Place Condominium Association, Inc., Unknown Spouse of Mitchell Roberts NKA Emily Roberts, are defendants, the Sarasota County Clerk of the Circuit Court will sell to the highest and best bidder for cash in/on the Internet: www.sarasota.realforeclose.com, Sarasota County, Florida at 9:00am on the 22nd day of January, 2014, the following described property as set forth in said Final Judgment of Foreclosure:
UNIT 6, THE VILLAGE AT BEEKMAN PLACE, SECTION 1, A LAND CONDOMINIUM, ACCORDING TO THE DECLARATION OF CONDOMINIUM

RECORDED IN OFFICIAL RECORDS BOOK 2348, PAGES 2795 THROUGH 2860, INCLUSIVE AND AS PER PLAT THEREOF, AS RECORDED IN CONDOMINIUM BOOK 29, PAGE 33D, INCLUSIVE, ALL OF THE PUBLIC RECORDS OF SARASOTA COUNTY, FLORIDA, TOGETHER WITH AN UNDIVIDED SHARE IN THE COMMON ELEMENTS APPURTENANT THERETO.
A/K/A 4354 EDINBRIDGE CIRCLE SARASOTA, FL 34235
Any person claiming an interest in the surplus from the sale, if any, other than the property owner as of the date of the Lis Pendens must file a claim within 60 days after the sale.
If you are a person with a disability who needs any accommodation in order to participate in this proceeding, you are entitled, at no cost to you, to the provision of certain assistance. Please contact the Sarasota County Jury Office, P.O. Box 3079, Sarasota, Florida 34230-3079, (941)861-7400, at least seven (7) days before your scheduled court appearance, or immediately upon receiving this notification if the time before the scheduled appearance is less than seven (7) days; if you are hearing or voice impaired, call 711.
Dated this 17 day of December, 2013.
By: Nicole A. Ramjattan
Florida Bar: 0089204
Jamie Epstein
Florida Bar: 68691
Robertson, Anschutz & Schneid, PL
Attorneys for Plaintiff
6409 Congress Avenue,
Suite 100
Boca Raton, Florida 33487
13-20960
December 20, 27, 2013 13-05995S

FIRST INSERTION

NOTICE OF FORECLOSURE SALE IN THE CIRCUIT COURT OF THE TWELFTH JUDICIAL CIRCUIT IN AND FOR SARASOTA COUNTY, FLORIDA
CASE NO. 2008 CA 016663 NC
THE BANK OF NEW YORK MELLON F/K/A THE BANK OF NEW YORK AS SUCCESSOR TO JPMORGAN CHASE BANK, N.A., AS TRUSTEE FOR THE BENEFIT OF THE CERTIFICATEHOLDERS OF POPULAR ABS, INC. Plaintiff, vs.
CARLOS A. CASTILLO AND LUIS BURELLI, et al. Defendant(s).
NOTICE IS HEREBY GIVEN pursuant to a Final Judgment of Foreclosure dated AUGUST 27, 2013, and entered in CasE No. 2008 CA 016663 NC of the Circuit Court of the Twelfth Judicial Circuit in and for Sarasota County, Florida, wherein THE BANK OF NEW YORK MELLON F/K/A THE BANK OF NEW YORK AS SUCCESSOR TO JPMORGAN CHASE BANK, N.A., AS TRUSTEE FOR THE BENEFIT OF THE CERTIFICATEHOLDERS OF POPULAR ABS, INC. MORTGAGE PASS-THROUGH CERTIFICATES SERIES 2005-6, is the Plaintiff and CARLOS A. CASTILLO; LUIS BURELLI; UNKNOWN SPOUSE OF CARLOS CASTILLO N/K/A WANDA CASTILLO; TENANT #1 N/K/A VICTOR HERNANDEZ are the Defendant(s). Karen Rushing as the Clerk of the Circuit Court will sell to the highest and best bidder for cash, www.sarasota.realforeclose.com, at 9:00 AM on JANUARY 7, 2014, the following described property as set forth in said Final Judgment, to wit:
LOT 99, THE GROVES, ACCORDING TO THE PLAT THEREOF RECORDED IN PLAT BOOK 27, PAGE 4, OF THE PUBLIC RECORDS OF SARASOTA COUNTY, FLORIDA.

ANY PERSON CLAIMING AN INTEREST IN THE SURPLUS FROM THE SALE, IF ANY, OTHER THAN THE PROPERTY OWNER AS OF THE DATE OF THE LIS PENDENS MUST FILE A CLAIM WITHIN 60 DAYS AFTER THE SALE.
If you are a person with a disability who needs any accommodation in order to participate in this proceeding, you are entitled, at no cost to you, to the provision of certain assistance. Please contact the Sarasota County Jury Office, P.O. Box 3079, Sarasota, Florida 34230-3079, (941)861-7400, at least seven (7) days before your scheduled court appearance, or immediately upon receiving this notification if the time before the scheduled appearance is less than seven (7) days; if you are hearing or voice impaired, call 711.
DATED this 17 day of December, 2013.
By: Nicole A. Ramjattan
Florida Bar: 0089204
Jamie Epstein
Florida Bar: 68691
Robertson, Anschutz & Schneid, PL
Attorneys for Plaintiff
6409 Congress Avenue,
Suite 100
Boca Raton, Florida 33487
13-20960
December 20, 27, 2013 13-05995S

FIRST INSERTION

NOTICE OF FORECLOSURE SALE IN THE CIRCUIT COURT OF THE 12TH JUDICIAL CIRCUIT, IN AND FOR SARASOTA COUNTY, FLORIDA
CIVIL DIVISION:
CASE NO.: 2010 CA 000203 NC
AURORA LOAN SERVICES, LLC, Plaintiff, vs.
ROBIN M. POTTS; CHARLESTON PARK HOME OWNERS ASSOCIATION, INC.; JOCKEY CLUB OF NORTH PORT PROPERTY OWNERS' ASSOCIATION, INC.; RONALD ALAN POTTS A/K/A RONALD A. POTTS; UNKNOWN TENANT(S); IN POSSESSION OF THE SUBJECT PROPERTY, Defendants.
NOTICE IS HEREBY GIVEN pursuant to Final Judgment of Foreclosure dated the 6th day of December, 2013, and entered in Case No. 2010 CA 000203 NC, of the Circuit Court of the 12TH Judicial Circuit in and for Sarasota County, Florida, wherein FEDERAL NATIONAL MORTGAGE ASSOCIATION is the Plaintiff and ROBIN M. POTTS; CHARLESTON PARK HOME OWNERS ASSOCIATION, INC.; JOCKEY CLUB OF NORTH PORT PROPERTY OWNERS' ASSOCIATION, INC.; RONALD ALAN POTTS A/K/A RONALD A. POTTS and UNKNOWN TENANT(S) IN POSSESSION OF THE SUBJECT PROPERTY are defendants. The Clerk of this Court shall sell to the highest and best bidder for cash electronically at www.sarasota.realforeclose.com at 9:00 AM on the 10th day of January, 2014, the following described property as set forth in said Final Judgment, to wit:

NOTICE OF SALE IN THE CIRCUIT COURT OF THE TWELFTH JUDICIAL CIRCUIT OF THE STATE OF FLORIDA, IN AND FOR SARASOTA COUNTY CIVIL DIVISION
CASE NO. 58-2011-CA-000033-XXA-NC
CITIMORTGAGE, INC. AS SUCCESSOR BY MERGER TO ABN AMRO MORTGAGE GROUP, INC., Plaintiff, vs.
LEIGH PATMAGRIAN; UNKNOWN SPOUSE OF LEIGH PATMAGRIAN; WILLIAM S. PATMAGRIAN; UNKNOWN SPOUSE OF WILLIAM S. PATMAGRIAN; IF LIVING, INCLUDING ANY UNKNOWN SPOUSE OF SAID DEFENDANT(S), IF REMARRIED, AND IF DECEASED, THE RESPECTIVE UNKNOWN HEIRS, DEVISEES, GRANTEEES, ASSIGNEES, CREDITORS, LIENORS, AND TRUSTEES, AND ALL OTHER PERSONS CLAIMING BY, THROUGH, UNDER OR AGAINST THE NAMED DEFENDANT(S); UNKNOWN TENANT #1; UNKNOWN TENANT #2; Defendant(s)
Notice is hereby given that, pursuant to a Final Summary Judgment of Foreclosure entered on 09/19/2013 in the above styled cause, in the Circuit Court of Sarasota County, Florida, the office of Karen E. Rushing clerk of the circuit court will sell the property situate in Sarasota County, Florida, described as:
THE NORTH 1/2 OF LOT 34, ALL OF LOT 35, AND THE SOUTH 1/2 OF LOT 36, BLOCK 'A', GROVE PARK, ACCORDING TO THE PLAT THEREOF, RECORDED IN PLAT BOOK 1, PAGE 109 OF THE PUBLIC RECORDS OF SARASOTA COUNTY, FLORIDA.
at public sale, to the highest and best bidder, for cash, www.sarasota.realforeclose.com at 9:00 o'clock, A.M., on January 17, 2014
Any person claiming an interest in the surplus from the sale, if any, other than the property owner as of the date of the lis pendens, must file a claim within 60 days after the sale.
If you are a person with a disability who needs any accommodation in order to participate in this proceeding, you are entitled, at no cost to you, to the provision of certain assistance. Please contact the Sarasota County Jury Office, P.O. Box 3079, Sarasota, Florida 34230-3079, (941)861-7400, at least seven (7) days before your scheduled court appearance, or immediately upon receiving this notification if the time before the scheduled appearance is less than seven (7) days; if you are hearing or voice impaired, call 711.
ATTORNEY FOR PLAINTIFF
By Josh D. Donnelly
Florida Bar #64788
Date: 12/17/2013
THIS INSTRUMENT PREPARED BY:
Law Offices Of Daniel C. Consuegra
9204 King Palm Drive
Tampa, FL 33619-1328
Phone: 813-915-8660
Attorneys for Plaintiff
83478
December 20, 27, 2013 13-05987S

FIRST INSERTION

NOTICE OF FORECLOSURE SALE IN THE CIRCUIT COURT OF THE 12TH JUDICIAL CIRCUIT, IN AND FOR SARASOTA COUNTY, FLORIDA
CIVIL DIVISION:
CASE NO.: 2010 CA 000203 NC
AURORA LOAN SERVICES, LLC, Plaintiff, vs.
ROBIN M. POTTS; CHARLESTON PARK HOME OWNERS ASSOCIATION, INC.; JOCKEY CLUB OF NORTH PORT PROPERTY OWNERS' ASSOCIATION, INC.; RONALD ALAN POTTS A/K/A RONALD A. POTTS; UNKNOWN TENANT(S); IN POSSESSION OF THE SUBJECT PROPERTY, Defendants.
NOTICE IS HEREBY GIVEN pursuant to Final Judgment of Foreclosure dated the 6th day of December, 2013, and entered in Case No. 2010 CA 000203 NC, of the Circuit Court of the 12TH Judicial Circuit in and for Sarasota County, Florida, wherein FEDERAL NATIONAL MORTGAGE ASSOCIATION is the Plaintiff and ROBIN M. POTTS; CHARLESTON PARK HOME OWNERS ASSOCIATION, INC.; JOCKEY CLUB OF NORTH PORT PROPERTY OWNERS' ASSOCIATION, INC.; RONALD ALAN POTTS A/K/A RONALD A. POTTS and UNKNOWN TENANT(S) IN POSSESSION OF THE SUBJECT PROPERTY are defendants. The Clerk of this Court shall sell to the highest and best bidder for cash electronically at www.sarasota.realforeclose.com at 9:00 AM on the 10th day of January, 2014, the following described property as set forth in said Final Judgment, to wit:

LOT 11, BLOCK 2623, OF THE 52ND ADDITION TO PORT CHARLOTTE SUBDIVISION, ACCORDING TO THE PLAT THEREOF, RECORDED IN PLAT BOOK 21, PAGES 13, 13A-13NN, OF THE PUBLIC RECORDS OF SARASOTA COUNTY, FLORIDA.
ANY PERSON CLAIMING AN INTEREST IN THE SURPLUS FROM THE SALE, IF ANY, OTHER THAN THE PROPERTY OWNER AS OF THE DATE OF THE LIS PENDENS MUST FILE A CLAIM WITHIN 60 DAYS AFTER THE SALE.
If you are a person with a disability who needs any accommodation in order to participate in this proceeding, you are entitled, at no cost to you, to the provision of certain assistance. Please contact the Sarasota County Jury Office, P.O. Box 3079, Sarasota, Florida 34230-3079, (941)861-7400, at least seven (7) days before your scheduled court appearance, or immediately upon receiving this notification if the time before the scheduled appearance is less than seven (7) days; if you are hearing or voice impaired, call 711.
DATED this 11th day of Dec., 2013.
By: Carri L. Pereyra
Bar #17441
Choice Legal Group, P.A.
1800 NW 49th Street, Suite 120
Fort Lauderdale, Florida 33309
Telephone: (954) 453-0365
Facsimile: (954) 771-6052
Toll Free: 1-800-441-2438
DESIGNATED PRIMARY E-MAIL FOR SERVICE PURSUANT TO FLA R. JUD. ADMIN 2.516
eservice@clelegalgroup.com
09-75326
December 20, 27, 2013 13-05889S

FIRST INSERTION

NOTICE OF FORECLOSURE SALE PURSUANT TO CHAPTER 45 IN THE CIRCUIT COURT OF THE TWELFTH JUDICIAL CIRCUIT IN AND FOR SARASOTA COUNTY, FLORIDA

CASE NO. 2009 CA 001381 NC WACHOVIA MORTGAGE FSB N/K/A WELLS FARGO BANK, N.A., Plaintiff(s), vs. NICHOLAS JODHAN; et al., Defendant(s).

NOTICE IS HEREBY GIVEN that Sale will be made pursuant to an Order or Final Summary Judgment. Final Judgment was awarded on April 9, 2012 in Civil Case No.:2009 CA 001381 NC, of the Circuit Court of the TWELFTH Judicial Circuit in and for SARASOTA County, Florida, wherein, WACHOVIA MORTGAGE FSB N/K/A WELLS FARGO BANK, N.A is the Plaintiff, and, NICHOLAS JODHAN; GINGER JODHAN; STONEBRIDGE COMMUNITY ASSOCIATION, INC.; UNITED STATES OF AMERICA; AND UNKNOWN TENANT(S) IN POSSESSION are Defendants.

The clerk of the court, Karen E. Rushing, will sell to the highest bidder for cash online at www.sarasota.realforeclose.com at 9:00 AM on January 3, 2014, the following described real property as set forth in said Final Summary Judgment, to wit:

LOT 100, STONEBRIDGE, UNIT 2, ACCORDING TO THE PLAT THEREOF, RECORDED IN PLAT BOOK 38, PAGE 41, OF THE PUBLIC RECORDS OF SARASOTA COUNTY, FLORIDA ANY PERSON CLAIMING AN INTEREST IN THE SURPLUS FUNDS FROM THE SALE, IF ANY, OTHER THAN THE PROPERTY OWNER AS OF THE DATE OF THE LIS PENDENS MUST FILE A CLAIM WITHIN 60 DAYS AFTER THE SALE.

If you are a person with a disability who needs any accommodation in order to participate in this proceeding, you are entitled, at no cost to you, to the provision of certain assistance. Please contact the Sarasota County Jury Office, P.O. Box 3079, Sarasota, Florida 34230-3079, (941)861-7400, at least seven (7) days before your scheduled court appearance, or immediately upon receiving this notification if the time before the scheduled appearance is less than seven (7) days; if you are hearing or voice impaired, call 711.

Dated this 09 day of DEC, 2013.
BY: Nalini Singh
Fla. Bar # 43700
Aldridge Connors, LLP
Attorney for Plaintiff(s)
1615 South Congress Avenue,
Suite 200
Delray Beach, FL 33445
Phone: 561.392.6391
Fax: 561.392.6965
Primary E-Mail:
ServiceMail@aclawllp.com
1175-2608B
December 20, 27, 2013 13-05888S

FIRST INSERTION

NOTICE OF SALE IN THE CIRCUIT COURT OF THE TWELFTH JUDICIAL CIRCUIT IN AND FOR SARASOTA COUNTY, FLORIDA

CASE NO.: 2013 CA 005575 NC KING'S GATE CLUB, INC., a Florida not-for-profit corporation, Plaintiff, v.

ERWIN L. MCMASTER, DECEASED, AND ANY UNKNOWN PARTY WHO MAY CLAIM AS HEIR, DEVISEE, GRANTEE, ASSIGNEE, LIENOR, CREDITOR, TRUSTEE OR OTHER CLAIMANT, BY, THROUGH, UNDER OR AGAINST ERWIN L. MCMASTER, DECEASED; MARIAN MCMASTER; SUSAN MCMASTER, Defendants.

Notice is hereby given pursuant to the Summary Final Judgment of foreclosure entered in the above-styled Case Number 2013 CA 005575 NC, in the Circuit Court of SARASOTA, Florida, that the Clerk of Court will sell the following property, in SARASOTA County, Florida, described as:

Certificate #318, of KING'S GATE CLUB, INC., a Florida not-for-profit corporation, together with that certain double-wide mobile home situated on Lot No. 318 in KING'S GATE CLUB.

said property having a street address of 318 Castle Drive, Nokomis, FL 34275, at public sale, to the highest and best bidder for cash, at www.sarasota.realforeclose.com, at 9:00 A.M. on January 28, 2014. The highest bidder shall immediately post with the Clerk, a deposit equal to 5% of the final bid. The deposit must be cash or cashier's check payable to the Clerk of Court and will be applied to the sale price at the time of final payment. Final payment must be made on or before 5:00 p.m. of the day of the sale by cash or cashier's check.

Any person claiming an interest in the surplus from the sale, if any, other than the property owner as of the date of the lis pendens must file a claim within sixty (60) days after the sale.

If you are a person with a disability who needs any accommodation in order to participate in this proceeding, you are entitled, at no cost to you, to the provision of certain assistance. Please contact the Sarasota County Jury Office, P.O. Box 3079, Sarasota, Florida 34230-3079, (941)861-7400, at least seven (7) days before your scheduled court appearance, or immediately upon receiving this notification if the time before the scheduled appearance is less than seven (7) days; if you are hearing or voice impaired, call 711.

Dated this 17th day of December, 2013.
By: LEAH K. BURTON, ESQUIRE
Leah K. Burton, Esq.
The Law Offices of Kevin T. Wells, P.A.
1800 2nd Street, Suite 808
Sarasota, FL 34236
December 20, 27, 2013 13-05972S

FIRST INSERTION

NOTICE OF RESCHEDULED SALE IN THE CIRCUIT COURT OF THE TWELFTH JUDICIAL CIRCUIT IN AND FOR SARASOTA COUNTY, FLORIDA CIVIL ACTION

CASE NO.: 2008 CA 010381 NC DIVISION: A

LASALLE BANK NATIONAL ASSOCIATION, AS TRUSTEE FOR FIRST FRANKLIN MORTGAGE LOAN TRUST 2007-FF1, MORTGAGE LOAN ASSET-BACKED CERTIFICATES, SERIES 2007-FF1, Plaintiff, vs. NINA BURWELL, et al, Defendant(s).

NOTICE IS HEREBY GIVEN Pursuant to an Order Rescheduling Foreclosure Sale dated on or about November 25, 2013, and entered in Case No. 2008 CA 010381 NC of the Circuit Court of the Twelfth Judicial Circuit in and for Sarasota County, Florida in which Lasalle Bank National Association, As Trustee For First Franklin Mortgage Loan Trust 2007-FF1, Mortgage Loan Asset-backed Certificates, Series 2007-FF1, is the Plaintiff and Nina Burwell are defendants, the Sarasota County Clerk of the Circuit Court will sell to the highest and best bidder for cash in/ on the Internet: www.sarasota.realforeclose.com, Sarasota County, Florida at 9:00am on the 27th day of January, 2014, the following described property as set forth in said Final Judgment of Foreclosure:

LOT 31, OF GLEN OAKS COUNTRY CLUB ESTATES, IN UNIT 1, ACCORDING TO THE PLAT THEREOF, AS RECORDED IN PLAT BOOK 17, AT PAGE 7 AND 7A, OF THE PUBLIC RECORDS OF SARASOTA COUNTY, FLORIDA.

A/K/A 3860 ALLENWOOD ST, SARASOTA, FL 34232-1206

Any person claiming an interest in the surplus from the sale, if any, other than the property owner as of the date of the Lis Pendens must file a claim within 60 days after the sale.

If you are a person with a disability who needs any accommodation in order to participate in this proceeding, you are entitled, at no cost to you, to the provision of certain assistance. Please contact the Sarasota County Jury Office, P.O. Box 3079, Sarasota, Florida 34230-3079, (941)861-7400, at least seven (7) days before your scheduled court appearance, or immediately upon receiving this notification if the time before the scheduled appearance is less than seven (7) days; if you are hearing or voice impaired, call 711.

Albertelli Law Attorney for Plaintiff
P.O. Box 23028
Tampa, FL 33623
(813) 221-4743
(813) 221-9171 facsimile
eService: servealaw@albertellilaw.com
BM - 10-42161
December 20, 27, 2013 13-05983S

FIRST INSERTION

NOTICE OF SALE PURSUANT TO CHAPTER 45 IN THE CIRCUIT COURT OF THE 12TH JUDICIAL CIRCUIT, IN AND FOR SARASOTA COUNTY, FLORIDA

CASE No.: 2009 CA 011853 NC The Bank of New York Mellon f/k/a The Bank of New York as Trustee for the Certificate holders of CWALT 2004-J8, Plaintiff, vs. Barbara J. Ulmer, Unknown Tenant #1 and Unknown Tenant #2, Defendants.

NOTICE OF SALE IS HEREBY GIVEN pursuant to a Summary Final Judgment of Foreclosure dated November 14, 2013, and entered in Case No. 2009 CA 011853 NC of the Circuit Court of the 12th Judicial Circuit in and for Sarasota County, Florida, wherein The Bank of New York Mellon f/k/a The Bank of New York as Trustee for the Certificate holders of CWALT 2004-J8, is Plaintiff and Barbara J. Ulmer, Unknown Tenant #1 and Unknown Tenant #2, are Defendants, I will sell to the highest and best bidder for cash via online at www.sarasota.realforeclose.com at 9:00A.M. on the 8th day of January, 2014, the following described property as set forth in said Summary Final Judgment, to wit:

Lot 16, Block 1978, 42nd Addition to Port Charlotte Subdivision, according to the Plat thereof as recorded in Plat Book 17, Pages 52, 52A through 52B, inclusive, of the public records of Sarasota County, Florida.

and all fixtures and personal property located therein or thereon, which are included as security in Plaintiff's mortgage.

Any person claiming an interest in the surplus funds from the sale, if any, other than the property owner as of the date of the lis pendens must file a claim within 60 days after the sale.

If you are a person with a disability who needs any accommodation in order to participate in this proceeding, you are entitled, at no cost to you, to the provision of certain assistance. Please contact the Sarasota County Jury Office, P.O. Box 3079, Sarasota, Florida 34230-3079, (941)861-7400, at least seven (7) days before your scheduled court appearance, or immediately upon receiving this notification if the time before the scheduled appearance is less than seven (7) days; if you are hearing or voice impaired, call 711.

Dated this 17th day of December 2013.
Clarfield, Okon, Salomone & Pincus, P.L.
By: Jonathan Giddens
FL Bar No. 0840041
Clarfield, Okon, Salomone & Pincus, P.L.
(813) 221-4743
West Palm Beach, FL 33401
(561) 713-1400
pleadings@cosplaw.com
December 20, 27, 2013 13-05986S

FIRST INSERTION

NOTICE OF SALE PURSUANT TO CHAPTER 45 IN THE CIRCUIT COURT OF THE TWELFTH JUDICIAL CIRCUIT IN AND FOR SARASOTA COUNTY, FLORIDA CIVIL ACTION

CASE NO.: 2012 CA 006714 NC DEUTSCHE BANK TRUST COMPANY AMERICAS, AS TRUSTEE FOR RALI 2007-QS10, Plaintiff, vs. EILEEN A. CARR, et al, Defendant(s).

NOTICE IS HEREBY GIVEN Pursuant to a Final Judgment of Foreclosure dated December 2, 2013, and entered in Case No. 2012 CA 006714 NC of the Circuit Court of the Twelfth Judicial Circuit in and for Sarasota County, Florida in which Deutsche Bank Trust Company Americas, as Trustee for RALI 2007-QS10, is the Plaintiff and Eileen A. Carr, Robert E. Carr, Tenant # 1, Tenant # 2, The Unknown Spouse of Eileen A. Carr, The Unknown Spouse of Robert E. Carr, are defendants, the Sarasota County Clerk of the Circuit Court will sell to the highest and best bidder for cash in/on the Internet: www.sarasota.realforeclose.com, Sarasota County, Florida at 9:00am on the 7th day of January, 2014, the following described property as set forth in said Final Judgment of Foreclosure:

LOT 11, BLOCK 2498, OF 50TH ADDITION TO PORT CHARLOTTE SUBDIVISION, ACCORDING TO THE PLAT THEREOF, AS RECORDED IN PLAT BOOK 21, PAGES 7, 7A THROUGH 7H, OF THE PUBLIC RECORDS OF SARASOTA COUNTY, FLORIDA.

A/K/A 5739 KENWOOD DR NORTH PORT FL 34287-3028

Any person claiming an interest in the surplus from the sale, if any, other than the property owner as of the date of the Lis Pendens must file a claim within 60 days after the sale.

If you are a person with a disability who needs any accommodation in order to participate in this proceeding, you are entitled, at no cost to you, to the provision of certain assistance. Please contact the Sarasota County Jury Office, P.O. Box 3079, Sarasota, Florida 34230-3079, (941)861-7400, at least seven (7) days before your scheduled court appearance, or immediately upon receiving this notification if the time before the scheduled appearance is less than seven (7) days; if you are hearing or voice impaired, call 711.

Dated this 17th day of December, 2013.
Albertelli Law Attorney for Plaintiff
P.O. Box 23028
Tampa, FL 33623
(813) 221-4743
(813) 221-9171 facsimile
eService: servealaw@albertellilaw.com
TS - 009299F01
December 20, 27, 2013 13-05967S

FIRST INSERTION

NOTICE OF SALE IN THE CIRCUIT COURT OF THE TWELFTH JUDICIAL CIRCUIT IN AND FOR SARASOTA COUNTY, FLORIDA

CASE No. 2013 CA 006871 NC BIRD BAY CONDOMINIUM ASSOCIATION, INC., a Florida not-for-profit corporation, Plaintiff, v. DAVID RILEY, Defendant.

Notice is hereby given pursuant to the Summary Final Judgment of foreclosure entered in the above-styled Case Number 2013 CA 006871 NC, in the Circuit Court of SARASOTA, Florida, that the Clerk of Court will sell the following property, in SARASOTA County, Florida, described as:

Unit 202, Building 49, BIRD BAY V, a Condominium, according to the Declaration of Condominium recorded in Official Records Book 1514, Page 478, and amendments thereto, and as per plat thereof, recorded in Condominium Book 18, Page 49, and amendments thereto, of the Public Records of Sarasota County, Florida,

said property having a street address of 634 E. Bird Bay Drive, #202, Venice, FL 34285, at public sale, to the highest and best bidder for cash, at www.sarasota.realforeclose.com, at 9:00 A.M. on January 28, 2014. The highest bidder shall immediately post with the Clerk, a deposit equal to 5% of the final bid. The deposit must be cash or cashier's check payable to the Clerk of Court and will be applied to the sale price at the time of final payment. Final payment must be made on or before 5:00 p.m. of the day of the sale by cash or cashier's check.

Any person claiming an interest in the surplus from the sale, if any, other than the property owner as of the date of the lis pendens must file a claim within sixty (60) days after the sale.

If you are a person with a disability who needs any accommodation in order to participate in this proceeding, you are entitled, at no cost to you, to the provision of certain assistance. Please contact the Sarasota County Jury Office, P.O. Box 3079, Sarasota, Florida 34230-3079, (941)861-7400, at least seven (7) days before your scheduled court appearance, or immediately upon receiving this notification if the time before the scheduled appearance is less than seven (7) days; if you are hearing or voice impaired, call 711.

Dated this 17th day of December, 2013.
By: LEAH K. BURTON, ESQUIRE
Leah K. Burton, Esq.
The Law Offices of Kevin T. Wells, P.A.
1800 2nd Street,
Suite 808
Sarasota, FL 34236
December 20, 27, 2013 13-05971S

FIRST INSERTION

NOTICE OF FORECLOSURE SALE IN THE CIRCUIT COURT OF THE TWELFTH JUDICIAL CIRCUIT IN AND FOR SARASOTA COUNTY, FLORIDA

CASE NO.: 2009-CA-015574-NC (A) FEDERAL NATIONAL MORTGAGE ASSOCIATION, Plaintiff, vs.

ELIZABETH M. MARRAPODI; CHRISTOPHER MARRAPODI; UNKNOWN TENANT #1; UNKNOWN TENANT #2 UNKNOWN TENANT(S) IN POSSESSION #1 and #2, and ALL OTHER UNKNOWN PARTIES, et al., Defendant(s).

NOTICE IS HEREBY GIVEN pursuant to a Final Summary Judgment of Foreclosure dated September 16, 2013, entered in Civil Case No.: 2009-CA-015574-NC (A) of the Circuit Court of the Twelfth Judicial Circuit in and for Sarasota County, Florida, wherein FEDERAL NATIONAL MORTGAGE ASSOCIATION, Plaintiff, and ELIZABETH M. MARRAPODI; CHRISTOPHER MARRAPODI, are Defendants.

KAREN E. RUSHING, The Clerk of the Circuit Court, will sell to the highest bidder for cash, www.sarasota.realforeclose.com, at 09:00 AM, on the 14th day of January, 2014, the following described real property as set forth in said Final Summary Judgment, to wit:

LOT 21, IN BLOCK 471, OF 8TH ADDITION TO PORT CHARLOTTE SUBDIVISION, ACCORDING TO THE PLAT THEREOF, AS RECORDED IN PLAT BOOK 12, AT PAGE(S) 20, 20A THROUGH 20, INCLUSIVE, OF THE PUBLIC RECORDS OF SARASOTA COUNTY, FLORIDA.

If you are a person claiming a right to funds remaining after the sale, you must file a claim with

the clerk no later than 60 days after the sale. If you fail to file a claim you will not be entitled to any remaining funds. After 60 days, only the owner of record as of the date of the lis pendens may claim the surplus.

If you cannot afford an attorney, contact Gulfoast Legal Services at (941)366-1746 or www.gulfoastlegal.org, or Legal Aid of Manasota at (941) 366-0038 or www.legalaid-ofmanasota.org. If you do not qualify for free legal assistance or do not know an attorney, you may call an attorney referral service (listed in the phone book), or contact the Florida Bar Lawyer Referral Service at (800)342-8011.

IF YOU ARE A PERSON WITH A DISABILITY WHO NEEDS ANY ACCOMMODATION IN ORDER TO PARTICIPATE IN THIS PROCEEDING, YOU ARE ENTITLED, AT NO COST TO YOU, TO THE PROVISION OF CERTAIN ASSISTANCE. PLEASE CONTACT THE SARASOTA COUNTY JURY OFFICE, P.O. BOX 3079, SARASOTA, FLORIDA 34230-3079, (941)861-7400, AT LEAST SEVEN (7) DAYS BEFORE YOUR SCHEDULED COURT APPEARANCE, OR IMMEDIATELY UPON RECEIVING THIS NOTIFICATION IF THE TIME BEFORE THE SCHEDULED APPEARANCE IS LESS THAN SEVEN (7) DAYS; IF YOU ARE HEARING OR VOICE IMPAIRED, CALL 711.

Dated: 12/11/13
By: Corey M. Ohayon
Fla. Bar No: 0051323
Attorney for Plaintiff:
Brian L. Rosaler, Esquire
Popkin & Rosaler, P.A.
1701 West Hillsboro Boulevard,
Suite 400
Deerfield Beach, FL 33442
Telephone: (954) 360-9030;
Facsimile: (954) 420-5187
11-27885
December 20, 27, 2013 13-05956S

NOTICE OF SALE IN THE CIRCUIT COURT OF THE TWELFTH JUDICIAL CIRCUIT OF THE STATE OF FLORIDA, IN AND FOR SARASOTA COUNTY CIVIL DIVISION

CASE NO. 58-2012-CA-001174-0000-NC U.S. BANK, NATIONAL ASSOCIATION, AS TRUSTEE FOR STRUCTURED ASSET INVESTMENT LOAN TRUST MORTGAGE PASS-THROUGH CERTIFICATES, SERIES 2006-4, Plaintiff, vs.

PEDRO R. FERRAN; WILLIAM J. KARY; KELLY A. KARY; LINDSAY DEGG; IF LIVING, INCLUDING ANY UNKNOWN SPOUSE OF SAID DEFENDANT(S), IF REMARRIED, AND IF DECEASED, THE RESPECTIVE UNKNOWN HEIRS, DEVISEES, GRANTEEES, ASSIGNEES, CREDITORS, LIENORS, AND TRUSTEES, AND ALL OTHER PERSONS

NOTICE OF FORECLOSURE SALE IN THE CIRCUIT COURT OF THE TWELFTH JUDICIAL CIRCUIT IN AND FOR SARASOTA COUNTY, FLORIDA

CASE NO.: 2012 CA 004836 NC FEDERAL NATIONAL MORTGAGE ASSOCIATION, Plaintiff, vs. WILLIAM PINTO; UNKNOWN SPOUSE OF WILLIAM PINTO; CITY OF SARASOTA; UNKNOWN TENANT(S) IN POSSESSION #1 and #2, and ALL OTHER UNKNOWN PARTIES, et al., Defendant(s).

NOTICE IS HEREBY GIVEN pursuant to a Final Summary Judgment of Foreclosure dated September 24, 2013, entered in Civil Case No.: 2012 CA 004836 NC of the Circuit Court of the Twelfth Judicial Circuit in and

CLAIMING BY, THROUGH, UNDER OR AGAINST THE NAMED DEFENDANT(S); NICE CITY HOMES, LLC; STATE OF FLORIDA DEPARTMENT OF REVENUE; CLERK OF THE CIRCUIT COURT OF SARASOTA COUNTY; UNITED STATES OF AMERICA; CAVALRY PORTFOLIO SERVICES, LLC AS ASSIGNEE OF CAVALRY SPV I, LLC AS ASSIGNEE OF KIA FINANCIAL SERVICES; PARK VIEW CONDOMINIUM ASSOCIATION, INC.; WHETHER DISSOLVED OR PRESENTLY EXISTING, TOGETHER WITH ANY GRANTEEES, ASSIGNEES, CREDITORS, LIENORS, OR TRUSTEES OF SAID DEFENDANT(S) AND ALL OTHER PERSONS CLAIMING BY, THROUGH, UNDER, OR AGAINST DEFENDANT(S); UNKNOWN TENANT #1; UNKNOWN TENANT #2; Defendant(s)

for Sarasota County, Florida, wherein FEDERAL NATIONAL MORTGAGE ASSOCIATION, Plaintiff, and WILLIAM PINTO; CITY OF SARASOTA, are Defendants.

KAREN E. RUSHING, The Clerk of the Circuit Court, will sell to the highest bidder for cash, www.sarasota.realforeclose.com, at 09:00 AM, on the 22nd day of January, 2014, the following described real property as set forth in said Final Summary Judgment, to wit:

LOT 13, BLOCK 58, 4TH ADDITION TO PORT CHARLOTTE SUBDIVISION, A SUBDIVISION ACCORDING TO THE PLAT THEREOF, AS RECORDED IN PLAT BOOK 11, PAGES 32, 32A-32H, OF THE PUBLIC RECORDS OF SARASOTA COUNTY, FLORIDA.

Notice is hereby given that, pursuant to a Final Summary Judgment of Foreclosure entered on 11/18/2013 in the above styled cause, in the Circuit Court of Sarasota County, Florida, the office of Karen E. Rushing clerk of the circuit court will sell the property situate in Sarasota County, Florida, described as: CONDOMINIUM UNIT NO. 1, BUILDING 966, PARK VIEW CONDOMINIUM, ACCORDING TO THE DECLARATION THEREOF, AS RECORDED IN INSTRUMENT NO. 2005108535, OF THE PUBLIC RECORDS OF SARASOTA COUNTY, FLORIDA.

at public sale, to the highest and best bidder, for cash, www.sarasota.realforeclose.com at 9:00 o'clock, A.M., on January 17, 2014.

Any person claiming an interest in the surplus from the sale, if any, other than the property owner as of the date of the lis pendens, must file a claim within 60 days after the sale.

If you cannot afford an attorney, contact Gulfoast Legal Services at (941) 366-0038 or www.legalaidofmanasota.org If you do not qualify for free legal assistance or do not know an attorney, you may call an attorney referral service (listed in the phone book), or contact the Florida Bar Lawyer Referral Service at (800) 342-8011.

If you are a person with a disability who needs any accommodation in order to participate in this proceeding, you are entitled, at no cost to you, to the provision of certain assistance. Please

If you are a person with a disability who needs any accommodation in order to participate in this proceeding, you are entitled, at no cost to you, to the provision of certain assistance. Please contact the Sarasota County Jury Office, P.O. Box 3079, Sarasota, Florida 34230-3079, (941)861-7400, at least seven (7) days before your scheduled court appearance, or immediately upon receiving this notification if the time before the scheduled appearance is less than seven (7) days; if you are hearing or voice impaired, call 711.

ATTORNEY FOR PLAINTIFF
By Josh D. Donnelly
Florida Bar #64788

Date: 12/17/2013
THIS INSTRUMENT PREPARED BY:
Law Offices Of Daniel C. Consuegra
9204 King Palm Drive
Tampa, FL 33619-1328
Phone: 813-915-8660
Attorneys for Plaintiff
114642
December 20, 27, 2013 13-05991S

FIRST INSERTION

NOTICE OF FORECLOSURE SALE IN THE CIRCUIT COURT OF THE TWELFTH JUDICIAL CIRCUIT IN AND FOR SARASOTA COUNTY, FLORIDA

CASE NO.: 2012 CA 004836 NC FEDERAL NATIONAL MORTGAGE ASSOCIATION, Plaintiff, vs. WILLIAM PINTO; UNKNOWN SPOUSE OF WILLIAM PINTO; CITY OF SARASOTA; UNKNOWN TENANT(S) IN POSSESSION #1 and #2, and ALL OTHER UNKNOWN PARTIES, et al., Defendant(s).

NOTICE IS HEREBY GIVEN pursuant to a Final Summary Judgment of Foreclosure dated September 24, 2013, entered in Civil Case No.: 2012 CA 004836 NC of the Circuit Court of the Twelfth Judicial Circuit in and

for Sarasota County, Florida, wherein FEDERAL NATIONAL MORTGAGE ASSOCIATION, Plaintiff, and WILLIAM PINTO; CITY OF SARASOTA, are Defendants.

KAREN E. RUSHING, The Clerk of the Circuit Court, will sell to the highest bidder for cash, www.sarasota.realforeclose.com, at 09:00 AM, on the 22nd day of January, 2014, the following described real property as set forth in said Final Summary Judgment, to wit:

LOT 13, BLOCK 58, 4TH ADDITION TO PORT CHARLOTTE SUBDIVISION, A SUBDIVISION ACCORDING TO THE PLAT THEREOF, AS RECORDED IN PLAT BOOK 11, PAGES 32, 32A-32H, OF THE PUBLIC RECORDS OF SARASOTA COUNTY, FLORIDA.

If you are a person claiming a right to funds remaining after the sale, you must file a claim with the clerk no later than 60 days after the sale. If you fail to file a claim you will not be entitled to any remaining funds. After 60 days, only the owner of record as of the date of the lis pendens may claim the surplus.

If you cannot afford an attorney, contact Gulfoast Legal Services at (941) 366-0038 or www.legalaidofmanasota.org If you do not qualify for free legal assistance or do not know an attorney, you may call an attorney referral service (listed in the phone book), or contact the Florida Bar Lawyer Referral Service at (800) 342-8011.

If you are a person with a disability who needs any accommodation in order to participate in this proceeding, you are entitled, at no cost to you, to the provision of certain assistance. Please

contact the Sarasota County Jury Office, P.O. Box 3079, Sarasota, Florida 34230-3079, (941)861-7400, at least seven (7) days before your scheduled court appearance, or immediately upon receiving this notification if the time before the scheduled appearance is less than seven (7) days; if you are hearing or voice impaired, call 711.

Dated: 12/17/13
By: Anthony C. Basalone
Florida Bar No.: 098242.
Attorney for Plaintiff:
Brian L. Rosaler, Esquire
Popkin & Rosaler, P.A.
1701 West Hillsboro Boulevard,
Suite 400
Deerfield Beach, FL 33442
Telephone: (954) 360-9030;
Facsimile: (954) 420-5187
12-34004
December 20, 27, 2013 13-05994S

FIRST INSERTION

NOTICE OF FORECLOSURE SALE IN THE CIRCUIT COURT OF THE 12TH JUDICIAL CIRCUIT, IN AND FOR SARASOTA COUNTY, FLORIDA

CIVIL DIVISION:
CASE NO.: 2012 CA 009085 NC
NATIONSTAR MORTGAGE, LLC., Plaintiff, vs.
PAUL MAJESKI; MORRILL ENCLAVE CONDOMINIUM ASSOCIATION, INC.; UNKNOWN TENANT (S) IN POSSESSION OF THE SUBJECT PROPERTY, Defendants.

NOTICE IS HEREBY GIVEN pursuant to Final Judgment of Foreclosure dated the 2nd day of December, 2013, and entered in Case No. 2012 CA 009085 NC, of the Circuit Court of the 12TH Judicial Circuit in and for Sarasota County, Florida, wherein NATIONSTAR MORTGAGE, LLC. is the Plaintiff and PAUL MAJESKI; MORRILL ENCLAVE CONDOMINIUM ASSOCIATION, INC. and UNKNOWN TENANT (S) IN POSSESSION OF THE SUBJECT PROPERTY are defendants. The Clerk of this Court shall sell to the highest and best bidder for cash electronically at www.sarasota.realforeclose.com at, 9:00 AM on the 7th day of January, 2014, the following described property as set forth in said Final Judgment, to wit:

CONDOMINIUM UNIT NO. 11, BUILDING 6, OF MORRILL ENCLAVE, A CONDOMINIUM, ACCORDING TO THE DECLARATION THEREOF, AS RECORDED OFFICIAL RECORDS INSTRUMENT 2006-220900, AND ALL AMENDMENTS THERETO, OF THE PUBLIC RECORDS OF SARASOTA COUNTY, FLORIDA

ANY PERSON CLAIMING AN INTEREST IN THE SURPLUS FROM THE SALE, IF ANY, OTHER THAN THE PROPERTY OWNER AS OF THE DATE OF THE LIS PENDENS MUST FILE A CLAIM WITHIN 60 DAYS AFTER THE SALE.

If you are a person with a disability who needs any accommodation in order to participate in this proceeding, you are entitled, at no cost to you, to the provision of certain assistance. Please contact the Sarasota County Jury Office, P.O. Box 3079, Sarasota, Florida 34230-3079, (941)861-7400, at least seven (7) days before your scheduled court appearance, or immediately upon receiving this notification if the time before the scheduled appearance is less than seven (7) days; if you are hearing or voice impaired, call 711.

Dated this 11 day of December, 2013.

By: Bruce K. Fay
Bar #97308

Choice Legal Group, P.A.
1800 NW 49th Street, Suite 120
Fort Lauderdale, Florida 33309
Telephone: (954) 453-0365
Facsimile: (954) 771-6052
Toll Free: 1-800-441-2438
DESIGNATED PRIMARY E-MAIL FOR SERVICE PURSUANT TO FLA R. JUD. ADMIN 2.516
eservice@clegalgroup.com
11-24404
December 20, 27, 2013 13-05891S

FIRST INSERTION

NOTICE OF SALE PURSUANT TO CHAPTER 45 IN THE CIRCUIT COURT OF THE TWELFTH JUDICIAL CIRCUIT IN AND FOR SARASOTA COUNTY, FLORIDA

CIVIL DIVISION
CASE NO. 2012 CA 009128 NC
THE BANK OF NEW YORK MELLON FKA THE BANK OF NEW YORK, AS TRUSTEE FOR THE CERTIFICATEHOLDERS CWABS, INC., ASSET-BACKED NOTES SERIES 2005-SD3 Plaintiff, vs.
Mack M. Williams, et al, Defendants/

NOTICE IS HEREBY GIVEN pursuant to an Order or Final Judgment of Foreclosure dated September 16, 2013, and entered in Case No. 2012 CA 009128 NC of the Circuit Court of the Twelfth Judicial Circuit in and for Sarasota County, Florida, wherein THE BANK OF NEW YORK MELLON FKA THE BANK OF NEW YORK, AS TRUSTEE FOR THE CERTIFICATEHOLDERS CWABS, INC., ASSET-BACKED NOTES SERIES 2005-SD3 is the Plaintiff and Mack M. Williams, Gail D. Williams, Lucille Curry, City Of Sarasota, the Defendants, I will sell to the highest and best bidder for cash www.sarasota.realforeclose.com, the Clerk's website for on-line auctions at 9:00 a.m. on January 14, 2014, the following described property as set forth in said Order of Final Judgment, to wit:

Lot 5, Block C, First Addition To Newtown Heights, As Per Plat Thereof Recorded In Plat Book 1, Page 199, Of The Public Records Of Sarasota County, Florida.

IF YOU ARE A PERSON CLAIMING A RIGHT TO FUNDS REMAINING AFTER THE SALE, YOU MUST FILE A CLAIM WITH THE CLERK OF COURT NO LATER THAN 60 DAYS AFTER THE SALE. IF YOU FAIL TO FILE A CLAIM, YOU WILL NOT BE ENTITLED TO ANY REMAINING FUNDS. AFTER 60 DAYS, ONLY THE OWNER OF RECORD AS OF THE DATE OF THE LIS PENDENS MAY CLAIM THE SURPLUS.

If you are a person with a disability who needs any accommodation in order to participate in this proceeding, you are entitled, at no cost to you, to the provision of certain assistance. Please contact the Sarasota County Jury Office, P.O. Box 3079, Sarasota, Florida 34230-3079, (941)861-7400, at least seven (7) days before your scheduled court appearance, or immediately upon receiving this notification if the time before the scheduled appearance is less than seven (7) days; if you are hearing or voice impaired, call 711.

DATED at Sarasota County, Florida, this 9th day of Dec., 2013.

By: Kalei McElroy Blair, Esq./
Florida Bar #44613
GILBERT GARCIA GROUP, P.A.,
Attorney for Plaintiff(s)
2005 PAN AM CIRCLE, SUITE 110
TAMPA, FL 33607
Phone: (813) 443-5087
Fax: (813) 443-5089
emailservice@gilbertgroup.com
972233.2639/nls
December 20, 27, 2013 13-05895S

FIRST INSERTION

NOTICE OF SALE PURSUANT TO CHAPTER 45 IN THE CIRCUIT COURT OF THE TWELFTH JUDICIAL CIRCUIT IN AND FOR SARASOTA COUNTY, FLORIDA

CIVIL ACTION
CASE NO.: 2010 CA 006718 NC
DIVISION: C
BANK OF AMERICA, NATIONAL ASSOCIATION AS SUCCESSOR BY MERGER TO LASALLE BANK NA AS TRUSTEE FOR WAMU MORTGAGE PASS-THROUGH CERTIFICATES SERIES 2007-OA6 TRUST, Plaintiff, vs.
ROSEMARY B. DALY A/K/A ROSEMARY DALY, et al, Defendant(s).

NOTICE IS HEREBY GIVEN Pursuant to a Final Judgment of Foreclosure dated September 23, 2013, and entered in Case No. 2010 CA 006718 NC of the Circuit Court of the Twelfth Judicial Circuit in and for Sarasota County, Florida in which Bank of America, National Association as successor by merger to LaSalle Bank NA as trustee for WaMu Mortgage Pass-Through Certificates Series 2007-OA6 Trust, is the Plaintiff and Rosemary B. Daly a/k/a Rosemary Daly, Laurel Woodlands Association of Homeowners, Inc., William Schulte a/k/a William Brian Schulte, are defendants, the Sarasota County Clerk of the Circuit Court will sell to the highest and best bidder for cash in/on the Internet: www.sarasota.realforeclose.com, Sarasota County, Florida at 9:00am on the 22nd day of January, 2014, the following described property as set forth in said Final Judgment of Foreclosure:

LOT 38, LAUREL WOODLANDS, ACCORDING TO THE PLAT THEREOF RECORDED IN PLAT BOOK 31, PAGE 42, OF THE PUBLIC RECORDS OF SARASOTA COUNTY, FLORIDA.

A/K/A 1126 HOOVER ST., NOKOMIS, FL 34275-4405

Any person claiming an interest in the surplus from the sale, if any, other than the property owner as of the date of the Lis Pendens must file a claim within 60 days after the sale.

If you are a person with a disability who needs any accommodation in order to participate in this proceeding, you are entitled, at no cost to you, to the provision of certain assistance. Please contact the Sarasota County Jury Office, P.O. Box 3079, Sarasota, Florida 34230-3079, (941)861-7400, at least seven (7) days before your scheduled court appearance, or immediately upon receiving this notification if the time before the scheduled appearance is less than seven (7) days; if you are hearing or voice impaired, call 711.

Albertelli Law
Attorney for Plaintiff
P.O. Box 23028
Tampa, FL 33607
(813) 221-4743
(813) 221-9171 facsimile
eService:servealaw@albertellilaw.com
BM - 10-41781
December 20, 27, 2013 13-05878S

FIRST INSERTION

NOTICE OF SALE PURSUANT TO CHAPTER 45 IN THE CIRCUIT COURT OF THE TWELFTH JUDICIAL CIRCUIT IN AND FOR SARASOTA COUNTY, FLORIDA

CIVIL DIVISION
CASE NO. 2010-CA-000681 NC
THE BANK OF NEW YORK MELLON FKA THE BANK OF NEW YORK, AS TRUSTEE FOR THE CERTIFICATEHOLDERS OF THE CWABS INC., ASSET-BACKED CERTIFICATES, 2007-12 Plaintiff, vs.
Dale Hutchison, et al, Defendants/

NOTICE IS HEREBY GIVEN pursuant to an Order or Final Judgment of Foreclosure dated November 7, 2011, and entered in Case No. 2010-CA-000681 NC of the Circuit Court of the Twelfth Judicial Circuit in and for Sarasota County, Florida, wherein THE BANK OF NEW YORK MELLON FKA THE BANK OF NEW YORK, AS TRUSTEE FOR THE CERTIFICATEHOLDERS OF THE CWABS INC., ASSET-BACKED CERTIFICATES, 2007-12 is the Plaintiff and Dale Hutchison, the Defendants, I will sell to the highest and best bidder for cash www.sarasota.realforeclose.com, the Clerk's website for on-line auctions at 9:00 a.m. on January 13, 2014, the following described property as set forth in said Order of Final Judgment, to wit:

The Northerly 1/2 Of Lot 11642 And All Of Lots 11643 And 11644, South Venice, Unit No. 44, According To The Plat Thereof, Recorded In Plat Book 7, Page 5, Of The Public Records Of Sarasota County, Florida.

IF YOU ARE A PERSON CLAIMING A RIGHT TO FUNDS REMAINING AFTER THE SALE, YOU MUST FILE A CLAIM WITH THE CLERK OF COURT NO LATER THAN 60 DAYS AFTER THE SALE. IF YOU FAIL TO FILE A CLAIM, YOU WILL NOT BE ENTITLED TO ANY REMAINING FUNDS. AFTER 60 DAYS, ONLY THE OWNER OF RECORD AS OF THE DATE OF THE LIS PENDENS MAY CLAIM THE SURPLUS.

If you are a person with a disability who needs any accommodation in order to participate in this proceeding, you are entitled, at no cost to you, to the provision of certain assistance. Please contact the Sarasota County Jury Office, P.O. Box 3079, Sarasota, Florida 34230-3079, (941)861-7400, at least seven (7) days before your scheduled court appearance, or immediately upon receiving this notification if the time before the scheduled appearance is less than seven (7) days; if you are hearing or voice impaired, call 711.

DATED at SARASOTA County, Florida, this 13th day of Dec, 2013.

By: Kalei McElroy Blair, Esq./
Florida Bar #44613
GILBERT GARCIA GROUP, P.A.,
Attorney for Plaintiff
2005 Pan Am Circle, Suite 110
Tampa, FL 33607
Phone: (813) 443-5087
Fax: (813) 443-5089
emailservice@gilbertgroup.com
972233.0048/nls
December 20, 27, 2013 13-05942S

FIRST INSERTION

NOTICE OF SALE PURSUANT TO CHAPTER 45 IN THE CIRCUIT COURT OF THE TWELFTH JUDICIAL CIRCUIT IN AND FOR SARASOTA COUNTY, FLORIDA

CIVIL ACTION
CASE NO.: 58-2010-CA-006735 NC
DIVISION: C
WELLS FARGO BANK, N.A., SUCCESSOR IN INTEREST TO WACHOVIA MORTGAGE, F.S.B. F/K/A WORLD SAVINGS BANK, F.S.B., Plaintiff, vs.
ANGELIQUE M. WENTLANDT, et al, Defendant(s).

NOTICE IS HEREBY GIVEN Pursuant to a Final Judgment of Foreclosure dated December 2, 2013, and entered in Case No. 58-2010-CA-006735 NC of the Circuit Court of the Twelfth Judicial Circuit in and for Sarasota County, Florida in which Wells Fargo Bank, N.A., successor in interest to Wachovia Mortgage, F.S.B. f/k/a World Savings Bank, F.S.B., is the Plaintiff and Angelique M. Wentlandt, The City of Sarasota, a Municipal Corporation of the State of Florida, are defendants, the Sarasota County Clerk of the Circuit Court will sell to the highest and best bidder for cash in/on the Internet: www.sarasota.realforeclose.com, Sarasota County, Florida at 9:00am on the 6th day of January, 2014, the following described property as set forth in said Final Judgment of Foreclosure:

THE WEST 12.52 FEET OF LOT 13 AND LOT 12 LESS THE WEST 22.52 FEET, BLOCK 944, FIFTEENTH ADDITION TO PORT CHARLOTTE SUBDIVISION, ACCORDING TO THE PLAT THEREOF IN PLAT BOOK 13, PAGE 14, OF THE PUBLIC RECORDS OF SARASOTA COUNTY, FLORIDA.

A/K/A 8300 AGRESS AVENUE, NORTH PORT, FL 34287

Any person claiming an interest in the surplus from the sale, if any, other than the property owner as of the date of the Lis Pendens must file a claim within 60 days after the sale.

If you are a person with a disability who needs any accommodation in order to participate in this proceeding, you are entitled, at no cost to you, to the provision of certain assistance. Please contact the Sarasota County Jury Office, P.O. Box 3079, Sarasota, Florida 34230-3079, (941)861-7400, at least seven (7) days before your scheduled court appearance, or immediately upon receiving this notification if the time before the scheduled appearance is less than seven (7) days; if you are hearing or voice impaired, call 711.

Albertelli Law
Attorney for Plaintiff
P.O. Box 23028
Tampa, FL 33623
(813) 221-4743
(813) 221-9171 facsimile
eService:servealaw@albertellilaw.com
TS - 10-40349
December 20, 27, 2013 13-05883S

FIRST INSERTION

NOTICE OF SALE IN THE CIRCUIT CIVIL COURT OF THE TWELFTH JUDICIAL CIRCUIT OF FLORIDA, IN AND FOR SARASOTA COUNTY

CIVIL DIVISION
Case No. 58 2009 CA 021869 NC
Division A
EMC MORTGAGE CORPORATION Plaintiff, vs.
STEVEN HIOTT, DENISE HIOTT, ANY AND ALL UNKNOWN PARTIES CLAIMING BY, THROUGH, UNDER, AND AGAINST THE HEREIN NAMED INDIVIDUAL DEFENDANT(S) WHO ARE NOT KNOWN TO BE DEAD OR ALIVE, WHETHER SAID UNKNOWN PARTIES MAY CLAIM AN INTEREST AS SPOUSES, HEIRS, DEVISEES, GRANTEES OR OTHER CLAIMANTS, WESTLAKE ESTATES OWNERS ASSOCIATION, INC., AND UNKNOWN TENANTS/OWNERS, Defendants.

Notice is hereby given, pursuant to Final Judgment of Foreclosure for Plaintiff entered in this cause on December 3, 2013, in the Circuit Court of Sarasota County, Florida, The Clerk of the Court will sell the property situated in Sarasota County, Florida described as:

LOT 56, WESTLAKE ESTATES SUBDIVISION, AS PER PLAT THEREOF RECORDED IN PLAT BOOK 25, PAGES 7 AND 7A, OF THE PUBLIC RECORDS OF SARASOTA COUNTY, FLORIDA.

and commonly known as: 5406 CREEPING HAMMOCK DR, SARASOTA, FL 34231; including the building, appurtenances, and fixtures located therein, at public sale, to the highest and best bidder, for cash, Sales are held online at: <https://www.sarasota.realforeclose.com>, on January 10, 2014 at 9:00 A.M.

Any persons claiming an interest in the surplus from the sale, if any, other than the property owner as of the date of the lis pendens must file a claim within 60 days after the sale.

If you are a person with a disability who needs any accommodation in order to participate in this proceeding, you are entitled, at no cost to you, to the provision of certain assistance. Please contact the Sarasota County Jury Office, P.O. Box 3079, Sarasota, Florida 34230-3079, (941)861-7400, at least seven (7) days before your scheduled court appearance, or immediately upon receiving this notification if the time before the scheduled appearance is less than seven (7) days; if you are hearing or voice impaired, call 711.

Karen E. Rushing
By: Frances Grace Cooper, Esquire
Attorney for Plaintiff
Edward B. Pritchard
(813) 229-0900 x1309
Kass Shuler, P.A.
P.O. Box 800
Tampa, FL 33601-0800
ForeclosureService@kasslaw.com
319850/1036917/amm1
December 20, 27, 2013 13-05943S

FIRST INSERTION

NOTICE OF FORECLOSURE SALE IN THE CIRCUIT COURT OF THE 12TH JUDICIAL CIRCUIT, IN AND FOR SARASOTA COUNTY, FLORIDA

CIVIL DIVISION:
CASE NO.: 2012 CA 010462 NC
BANK OF AMERICA, N.A., Plaintiff, vs.

CATHERINE L. GRAY; JPMORGAN CHASE BANK, NA; CATHERINE L. GRAY AS TRUSTEE OF THE CATHERINE L. GRAY LIVING TRUST DATED MARCH 17, 2006; UNKNOWN BENEFICIARIES OF THE CATHERINE L. GRAY LIVING TRUST DATED MARCH 17, 2006; UNKNOWN TENANT IN POSSESSION OF THE SUBJECT PROPERTY, Defendants.

NOTICE IS HEREBY GIVEN pursuant to Final Judgment of Foreclosure dated the 5th day of December, 2013, and entered in Case No. 2012 CA 010462 NC, of the Circuit Court of the 12TH Judicial Circuit in and for Sarasota County, Florida, wherein BANK OF AMERICA, N.A. is the Plaintiff and CATHERINE L. GRAY; JPMORGAN CHASE BANK, NA; CATHERINE L. GRAY AS TRUSTEE OF THE CATHERINE L. GRAY LIVING TRUST DATED MARCH 17, 2006; UNKNOWN BENEFICIARIES OF THE CATHERINE L. GRAY LIVING TRUST DATED MARCH 17, 2006 AND UNKNOWN TENANT (S) IN POSSESSION OF THE SUBJECT PROPERTY are defendants. The Clerk of this Court shall sell to the highest and best bidder for cash electronically at www.sarasota.realforeclose.com at, 9:00 AM on the 10th day of January, 2014, the following described property as set forth in said Final Judgment, to wit:

LOT 14, BLOCK 1743, 34TH ADDITION TO PORT CHARLOTTE SUBDIVISION, A SUBDIVISION, ACCORDING TO THE PLAT THEREOF, AS RECORDED IN PLAT BOOK 15, PAGE 18, 18-A THROUGH 18-M, OF THE PUBLIC RECORDS OF SARASOTA COUNTY, FLORIDA

ANY PERSON CLAIMING AN INTEREST IN THE SURPLUS FROM THE SALE, IF ANY, OTHER THAN THE PROPERTY OWNER AS OF THE DATE OF THE LIS PENDENS MUST FILE A CLAIM WITHIN 60 DAYS AFTER THE SALE.

If you are a person with a disability who needs any accommodation in order to participate in this proceeding, you are entitled, at no cost to you, to the provision of certain assistance. Please contact the Sarasota County Jury Office, P.O. Box 3079, Sarasota, Florida 34230-3079, (941)861-7400, at least seven (7) days before your scheduled court appearance, or immediately upon receiving this notification if the time before the scheduled appearance is less than seven (7) days; if you are hearing or voice impaired, call 711.

Dated this 11 day of December, 2013.

By: Michael D.P. Phillips
Bar #653268
Choice Legal Group, P.A.
1800 NW 49th Street,
Suite 120
Fort Lauderdale, Florida 33309
Telephone: (954) 453-0365
Facsimile: (954) 771-6052
Toll Free: 1-800-441-2438
DESIGNATED PRIMARY E-MAIL FOR SERVICE PURSUANT TO FLA R. JUD. ADMIN 2.516
eservice@clegalgroup.com
08-01476
December 20, 27, 2013 13-05890S

FIRST INSERTION

NOTICE OF SALE IN THE CIRCUIT COURT OF THE TWELFTH JUDICIAL CIRCUIT OF THE STATE OF FLORIDA, IN AND FOR SARASOTA COUNTY

CIVIL DIVISION
CASE NO.
58-2010-CA-007470-XXXX-NC
CAPITAL ONE, N.A., Plaintiff, vs.

MARK S. LOTZ; UNKNOWN SPOUSE OF MARK S. LOTZ; JAMIE F. LOTZ; UNKNOWN SPOUSE OF JAMIE F. LOTZ; IF LIVING, INCLUDING ANY UNKNOWN SPOUSE OF SAID DEFENDANT(S), IF REMARRIED, AND IF DECEASED, THE RESPECTIVE UNKNOWN HEIRS, DEVISEES, GRANTEES, ASSIGNEES, CREDITORS, LIENORS, AND TRUSTEES, AND ALL OTHER PERSONS CLAIMING BY, THROUGH, UNDER OR AGAINST THE NAMED DEFENDANT(S); MORTGAGE ELECTRONIC REGISTRATION SYSTEMS INC., AS NOMINEE FOR B.F. SAUL MORTGAGE COMPANY; WHETHER DISSOLVED OR PRESENTLY EXISTING, TOGETHER WITH ANY GRANTEES, ASSIGNEES, CREDITORS, LIENORS, OR TRUSTEES OF SAID DEFENDANT(S) AND ALL OTHER PERSONS CLAIMING BY, THROUGH, WHETHER UNDER, OR AGAINST DEFENDANT(S); UNKNOWN TENANT #1; UNKNOWN TENANT #2; Defendant(s)

Notice is hereby given that, pursuant to a Final Summary Judgment of Foreclosure entered on 08/20/2012 in the above styled cause, in the Circuit Court of Sarasota County, Florida, the office

of Karen E. Rushing clerk of the circuit court will sell the property situate in Sarasota County, Florida, described as: LOT 14 AND THE EAST 1/2 OF LOT 12, BLOCK A, LEWIS COMBS SUBDIVISION, ACCORDING TO THE PLAT THEREOF, AS RECORDED IN PLAT BOOK 1, PAGE 22, OF THE PUBLIC RECORDS OF SARASOTA COUNTY, FLORIDA.

at public sale, to the highest and best bidder, for cash, www.sarasota.realforeclose.com at 9:00 o'clock, A.M., on January 8, 2014

Any person claiming an interest in the surplus from the sale, if any, other than the property owner as of the date of the lis pendens, must file a claim within 60 days after the sale.

If you are a person with a disability who needs any accommodation in order to participate in this proceeding, you are entitled, at no cost to you, to the provision of certain assistance. Please contact the Sarasota County Jury Office, P.O. Box 3079, Sarasota, Florida 34230-3079, (941)861-7400, at least seven (7) days before your scheduled court appearance, or immediately upon receiving this notification if the time before the scheduled appearance is less than seven (7) days; if you are hearing or voice impaired, call 711.

ATTORNEY FOR PLAINTIFF
By Josh D. Donnelly
Florida Bar #64788
Date: 12/11/2013
THIS INSTRUMENT PREPARED BY:
Law Offices Of Daniel C. Consuegra
9204 King Palm Drive
Tampa, FL 33619-1328
Phone: 813-915-8660
Attorneys for Plaintiff
68806
December 20, 27, 2013 13-05892S

FIRST INSERTION

NOTICE OF SALE PURSUANT TO CHAPTER 45 IN THE TWELFTH JUDICIAL CIRCUIT IN AND FOR SARASOTA COUNTY, FLORIDA

CIVIL
CASE NO.: 2010-CA-000953-NC
WILMINGTON SAVINGS FUND SOCIETY, FSB, NOT IN ITS INDIVIDUAL CAPACITY BUT SOLELY AS TRUSTEE OF THE PRIMESTAR-H FUND I TRUST, Plaintiff, vs.

MIDGE IVIE-TYNER A/K/A MIDGE IVIE TURNER; UNKNOWN SPOUSE OF MIDGE IVIE-TYNER A/K/A MIDGE IVIE TUNER; GATOR CREEK ESTATES IMPROVEMENT ASSOCIATION, INC.; UNKNOWN TENANT #1; UNKNOWN TENANT #2 Defendant(s).

NOTICE IS HEREBY GIVEN pursuant to an Order or Final Judgment of Foreclosure dated December 3, 2013, and entered in Case No. 2010-CA-000953-NC of the Circuit Court of the Twelfth Judicial Circuit in and for SARASOTA County, Florida, wherein WILMINGTON SAVINGS FUND SOCIETY, FSB, NOT IN ITS INDIVIDUAL CAPACITY BUT SOLELY AS TRUSTEE OF THE PRIMESTAR-H FUND I TRUST is the Plaintiff and MIDGE IVIE-TYNER A/K/A MIDGE IVIE TURNER; UNKNOWN SPOUSE OF MIDGE IVIE-TYNER A/K/A MIDGE IVIE TUNER; GATOR CREEK ESTATES IMPROVEMENT ASSOCIATION, INC.; UNKNOWN TENANT #1; UNKNOWN TENANT #2 are the Defendants. All Judicial Foreclosure Sales are held online via the Internet at www.sarasota.realforeclose.com pursuant to Florida Statute 45.031(10), at 9:00 AM EST on the 13th day of January, 2014, the following described property as set forth in

said Order of Final Judgment, to wit: LOT 48, GATOR CREEK ESTATES, UNIT 1, ACCORDING TO THE PLAT THEREOF RECORDED IN PLAT BOOK 23, PAGES 2, 2A, 2B AND 2C, OF THE PUBLIC RECORDS OF SARASOTA COUNTY, FLORIDA.

IF YOU ARE A PERSON CLAIMING A RIGHT TO FUNDS REMAINING AFTER THE SALE, YOU MUST FILE A CLAIM WITH THE CLERK OF COURT NO LATER THAN 60 DAYS AFTER THE SALE. IF YOU FAIL TO FILE A CLAIM, YOU WILL NOT BE ENTITLED TO ANY REMAINING FUNDS. AFTER 60 DAYS, ONLY THE OWNER OF RECORD AS OF THE DATE OF THE LIS PENDENS MAY CLAIM THE SURPLUS.

If you are a person with a disability who needs any accommodation in order to participate in this proceeding, you are entitled, at no cost to you, to the provision of certain assistance. Please contact the Sarasota County Jury Office, P.O. Box 3079, Sarasota, Florida 34230-3079, (941)861-7400, at least seven (7) days before your scheduled court appearance, or immediately upon receiving this notification if the time before the scheduled appearance is less than seven (7) days; if you are hearing or voice impaired, call 711.

By: /s/ Kent D. McPhail
Kent D. McPhail, Esq.
Fla. Bar # 852767
Primary E-Mail:
flservice@dumasmcpmail.com
DUMAS & MCPHAIL, L.L.C.
Attorney for Plaintiff
126 Government Street (36602)
Post Office Box 870
Mobile, AL 36601
(251) 438-2333
FL-13-0095
December 20, 27, 2013 13-05893S

FIRST INSERTION

NOTICE OF FORECLOSURE SALE IN THE CIRCUIT COURT OF THE 12th JUDICIAL CIRCUIT, IN AND FOR SARASOTA COUNTY, FLORIDA
 GENERAL JURISDICTION DIVISION
CASE NO. 2012 CA 000778 NC
OCWEN LOAN SERVICING, LLC, PLAINTIFF, VS. TERESA JUNE BURGE, ET AL., DEFENDANT(S).
 NOTICE IS HEREBY GIVEN pursuant to a Final Judgment of Foreclosure dated December 2, 2013 and entered in Case No. 2012 CA 000778 NC in the Circuit Court of the 12th Judicial Circuit in and for Sarasota County, Florida wherein OCWEN LOAN SERVICING, LLC was the Plaintiff and TERESA JUNE BURGE, ET AL., the Defendant(s). The Clerk will sell to the highest and best bidder for cash, by electronic sale beginning at 9:00 a.m. on the prescribed date at www.sarasota.realforeclose.com on the 7th day of January, 2014, the following described property as set forth in said Final Judgment:
 LOT 22, BLOCK 7, VENICE GROVES SUBDIVISION, A SUBDIVISION ACCORDING TO THE RECORDED PLAT THEREOF, RECORDED IN PLAT BOOK 3, PAGES 2 AND 2A, INCLUSIVE, PUBLIC RECORDS OF SARASOTA COUNTY, FLORIDA.
 ANY PERSON CLAIMING AN INTEREST IN THE SURPLUS FROM THE SALE, IF ANY, OTHER THAN THE PROPERTY OWNER, AS OF THE DATE OF THE LIS PENDENS, MUST FILE A CLAIM WITHIN SIXTY (60) DAYS AFTER THE SALE.
 If you are a person with a disability who needs any accommodation in order to participate in this proceeding, you are entitled, at no cost to you, to the provision of certain assistance. Please contact the Sarasota County Jury Office, P.O. Box 3079, Sarasota, Florida 34230-3079, (941)861-7400, at least seven (7) days before your scheduled court appearance, or immediately upon receiving this notification if the time before the scheduled appearance is less than seven (7) days; if you are hearing or voice impaired, call 711.
 This 11th day of December, 2013,
 s/Stephen M. Huttman
 Stephen M. Huttman
 Florida Bar # 102673
 Bus. Email: shuttman@penderlaw.com
 Pendergast & Morgan, P.A.
 115 Perimeter Center Place
 South Terraces Suite 1000
 Atlanta, GA 30346
 Telephone: 678-775-0700
 PRIMARY SERVICE:
 flfc@penderlaw.com
 Attorney for Plaintiff
 FAX: 678-381-8548
 11-13135 dgl_fl
 December 20, 27, 2013 13-05896S

FIRST INSERTION

NOTICE OF FORECLOSURE SALE IN THE CIRCUIT COURT OF THE 12th JUDICIAL CIRCUIT, IN AND FOR SARASOTA COUNTY, FLORIDA
 GENERAL JURISDICTION DIVISION
CASE NO. 2011 CA 006774 NC
U.S. BANK NATIONAL ASSOCIATION AS TRUSTEE RASC 2007KS3, PLAINTIFF, VS. ANTONIA RAMOS, ET AL., DEFENDANT(S).
 NOTICE IS HEREBY GIVEN pursuant to a Final Judgment of Foreclosure dated December 2, 2013 and entered in Case No. 2011 CA 006774 NC in the Circuit Court of the 12th Judicial Circuit in and for Sarasota County, Florida wherein U.S. Bank National Association as Trustee RASC 2007KS3 was the Plaintiff and ANTONIA RAMOS, ET AL., the Defendant(s). The Clerk will sell to the highest and best bidder for cash, by electronic sale beginning at 9:00 a.m. on the prescribed date at www.sarasota.realforeclose.com on the 3rd day of March, 2014, the following described property as set forth in said Final Judgment:
 LOT 5, BLOCK 3, SOUTHRIDGE SUBDIVISION, UNIT 1, ACCORDING TO A PLAT THEREOF RECORDED IN PLAT BOOK 12, PAGES 12 AND 12A OF THE PUBLIC RECORDS OF SARASOTA COUNTY, FLORIDA.
 ANY PERSON CLAIMING AN INTEREST IN THE SURPLUS FROM THE SALE, IF ANY, OTHER THAN THE PROPERTY OWNER, AS OF THE DATE OF THE LIS PENDENS, MUST FILE A CLAIM WITHIN SIXTY (60) DAYS AFTER THE SALE.
 If you are a person with a disability who needs any accommodation in order to participate in this proceeding, you are entitled, at no cost to you, to the provision of certain assistance. Please contact the Sarasota County Jury Office, P.O. Box 3079, Sarasota, Florida 34230-3079, (941)861-7400, at least seven (7) days before your scheduled court appearance, or immediately upon receiving this notification if the time before the scheduled appearance is less than seven (7) days; if you are hearing or voice impaired, call 711.
 This 11th day of December, 2013,
 s/Stephen M. Huttman
 Stephen M. Huttman
 Florida Bar # 102673
 Bus. Email: shuttman@penderlaw.com
 Pendergast & Morgan, P.A.
 115 Perimeter Center Place
 South Terraces Suite 1000
 Atlanta, GA 30346
 Telephone: 678-775-0700
 PRIMARY SERVICE:
 flfc@penderlaw.com
 Attorney for Plaintiff
 FAX: 678-381-8548
 11-04113 dgl_fl
 December 20, 27, 2013 13-05897S

FIRST INSERTION

NOTICE OF ACTION IN THE CIRCUIT COURT OF THE TWELFTH JUDICIAL CIRCUIT IN AND FOR SARASOTA COUNTY, FLORIDA
 CIVIL DIVISION
CASE NO. 2013 CA 006917 NC
DIV C
SUNCOAST SCHOOLS FEDERAL CREDIT UNION, Plaintiff, v. DOROTHY GROTEFENT, et al, Defendants.
 TO: UNKNOWN HEIRS OF DOROTHY GROTEFENT, and all unknown parties claiming by, through, under or against the above named Defendant(s), who are not known to be dead or alive, whether said unknown parties claim as heirs, devisees, grantees, assignees, lienors, creditors, trustees, spouses, or other claimants.
 Current Residence Unknown, but whose last known address was: UNKNOWN
 YOU ARE NOTIFIED that an action to foreclose a mortgage on the following property in SARASOTA County, Florida, to-wit:
 LOT 845, KENSINGTON PARK, UNIT 7, AS PER PLAT THEREOF RECORDED IN PLAT BOOK 16, 16A AND 16B, OF THE PUBLIC RECORDS OF SARASOTA COUNTY, FLORIDA.
 has been filed against you and you are required to serve a copy of your written defenses, if any, to it on Robert M. Copen, Esquire, Robert M. Copen, P.A., 10225 Ulmerton Road, Suite 5A, Largo, FL 33771, on or before 1-20-2014 or within thirty (30) days after the first publication of this Notice of Action, and file the original with the Clerk of this Court at 2000 Main Street, Sarasota FL 34237, either before service on Plaintiff's attorney or immediately thereafter; otherwise, a default will be entered against you for the relief demanded in the complaint petition.
 If you are a person with a disability who needs any accommodation in order to participate in this proceeding, you are entitled, at no cost to you, to the provision of certain assistance. Please contact the Sarasota County Jury Office, P.O. Box 3079, Sarasota, Florida 34230-3079, (941)861-7400, at least seven (7) days before your scheduled court appearance, or immediately upon receiving this notification if the time before the scheduled appearance is less than seven (7) days; if you are hearing or voice impaired, call 711.
 WITNESS my hand and seal of the Court on this 9 day of December 2013.
 KAREN E. RUSHING
 Clerk of the Court
 (SEAL) By G. Kopinsky
 Deputy Clerk
 Robert M. Copen, P.A.
 10225 Ulmerton Rd, Suite 5A
 Largo, FL 33771
 Phone 757-588-4550
 December 20, 27, 2013 13-05918S

FIRST INSERTION

NOTICE OF SALE IN THE CIRCUIT COURT OF THE TWELFTH JUDICIAL CIRCUIT IN & FOR SARASOTA COUNTY, FLORIDA
Case No.: 2012 CA 009896 NC
BANK OF AMERICA, N.A., ACTING BY AND THROUGH GREEN TREE SERVICING LLC, AS SERVICING AGENT 345 ST. PETER STREET 1100 LANDMARK TOWERS ST. PAUL, MN 55102, Plaintiff, v. KOLIO J. STOIANOF, THE UNKNOWN SPOUSE OF KOLIO J. STOIANOF, Defendants.
 NOTICE IS HEREBY GIVEN THAT, pursuant to Plaintiff's Final Judgment of Foreclosure entered in the above-captioned action, I will sell the property situated in Sarasota County, Florida, described as follows, to wit:
 THE EAST 35 FEET OF LOT 14 AND LOT 15, LESS THE EAST 45 FEET, BLOCK 942, 38TH ADDITION TO PORT CHARLOTTE SUBDIVISION, AS PER PLAT THEREOF RECORDED IN PLAT BOOK 16, PAGES 5, 5A AND 5B, OF THE PUBLIC RECORDS OF SARASOTA COUNTY, FLORIDA.
 Commonly known as: 8241 DOROTHY AVENUE, NORTH PORT, FLORIDA 34287, at public sale, to the highest and best bidder, for cash at www.sarasota.realforeclose.com at 9:00 AM (EST), or as soon as possible thereafter, on the 9th day of January, 2014.
 If you are a subordinate lien holder claiming a right to funds remaining after the sale, you must file a claim with the Clerk of Court no later than 60 days after the sale. If you fail to file a claim, you will not be entitled to any remaining funds.
 If you are a person with a disability who needs any accommodation in order to participate in this proceeding, you are entitled, at no cost to you, to the provision of certain assistance. Please contact the Sarasota County Jury Office, P.O. Box 3079, Sarasota, Florida 34230-3079, (941)861-7400, at least seven (7) days before your scheduled court appearance, or immediately upon receiving this notification if the time before the scheduled appearance is less than seven (7) days; if you are hearing or voice impaired, call 711.
 JONELLE M. RAINFORD, ESQ.
 Florida Bar #: 100355
 Respectfully Submitted,
 TIMOTHY D. PADGETT, P.A.
 6267 Old Water Oak Rd., Ste. 203
 Tallahassee, Florida 32312
 (850) 422-2520 (telephone)
 (850) 422-2567 (facsimile)
 attorney@padgettlanet.net
 Attorneys for Plaintiff
 December 20, 27, 2013 13-05954S

FIRST INSERTION

NOTICE OF FORECLOSURE SALE IN THE CIRCUIT COURT OF THE TWELFTH JUDICIAL CIRCUIT, IN AND FOR SARASOTA COUNTY, FLORIDA
 GENERAL JURISDICTION DIVISION
Case No. 2009 CA 011305 NC
U.S. Bank National Association as Trustee for RASC 2007KS1, Plaintiff, vs. Carl Wayne Deer a/k/a Carl Deer; et al. Defendants.
 NOTICE IS HEREBY GIVEN pursuant to a Final Judgment of Foreclosure dated November 14, 2013, entered in Case No. 2009 CA 011305 NC of the Circuit Court of the Twelfth Judicial Circuit, in and for Sarasota County, Florida, wherein U.S. Bank National Association as Trustee for RASC 2007KS1 is the Plaintiff and Carl Wayne Deer a/k/a Carl Deer; Patricia Alice Deer a/k/a Patricia Deer; Unknown Spouse of Carl Wayne Deer a/k/a Carl Deer; Unknown Spouse of Patricia Alice Deer a/k/a Patricia Deer; Unknown Tenant (s) in Possession of subject property are the Defendants, that the Clerk of Courts will sell to the highest and best bidder for cash by electronic sale at www.sarasota.realforeclose.com, beginning at 9:00 AM on the 8th day of January, 2014, the following described property as set forth in said Final Judgment, to wit:
 LOTS 1 AND 2, BLOCK 511, 11TH ADDITION TO PORT CHARLOTTE SUBDIVISION, ACCORDING TO THE PLAT THEREOF, RECORDED IN PLAT BOOK 13, PAGE 2 THROUGH 21, OF THE PUBLIC RECORDS OF SARASOTA COUNTY, FLORIDA.
 If you are a person with a disability who needs any accommodation in order to participate in this proceeding, you are entitled, at no cost to you, to the provision of certain assistance. Please contact the Sarasota County Jury Office, P.O. Box 3079, Sarasota, Florida 34230-3079, (941)861-7400, at least seven (7) days before your scheduled court appearance, or immediately upon receiving this notification if the time before the scheduled appearance is less than seven (7) days; if you are hearing or voice impaired, call 711.
 Dated this 16th day of December, 2013.
 By Jimmy Keenan Edwards
 Bar #81855
 for Jessica Fagen, Esq.
 Florida Bar No. 50668
 BROCK & SCOTT, PLLC
 Attorney for Plaintiff
 1501 N.W. 49th Street, Suite 200
 Ft. Lauderdale, FL 33309
 Phone: (954) 618-6955, ext. 6105
 Fax: (954) 618-6954
 FLCourtDocs@brockandscott.com
 File 13-F02956
 December 20, 27, 2013 13-05951S

FIRST INSERTION

NOTICE OF FORECLOSURE SALE IN THE CIRCUIT COURT IN AND FOR SARASOTA COUNTY, FLORIDA
CASE NO: 2012 CA 006317 NC
JPMORGAN CHASE BANK, NATIONAL ASSOCIATION Plaintiff, vs. SCOTT BOMBARD A/K/A SCOTT D. BOMBARD; LEANNE BOMBARD A/K/A LEANNE S. BOMBARD; UNKNOWN TENANT I; UNKNOWN TENANT II, and any unknown heirs, devisees, grantees, creditors, and other unknown persons or unknown spouses claiming by, through and under any of the above-named Defendants, Defendants.
 NOTICE is hereby given that the Clerk of the Circuit Court of Sarasota County, Florida, will on the 10th day of January 2014 at 9am www.sarasota.realforeclose.com, in accordance with Chapter 45 Florida Statutes, offer for sale and sell at public outcry to the highest and best bidder for cash, the following-described property situate in Sarasota County, Florida:
 LOT 10, BLOCK 7, VENICE EAST SECTION ONE, ACCORDING TO THE PLAT THEREOF AS RECORDED IN PLAT BOOK 12, PAGE 13, OF THE PUBLIC RECORDS OF SARASOTA COUNTY, FLORIDA.
 pursuant to the Final Judgment entered in a case pending in said Court, the style of which is indicated above.
 Any person or entity claiming an interest in the surplus, if any, resulting from the foreclosure sale, other than the property owner as of the date of the Lis Pendens, must file a claim on same with the Clerk of Court within 60 days after the foreclosure sale.
 If you are a person with a disability who needs any accommodation in order to participate in this proceeding, you are entitled, at no cost to you, to the provision of certain assistance. Please contact the Sarasota County Jury Office, P.O. Box 3079, Sarasota, Florida 34230-3079, (941)861-7400, at least seven (7) days before your scheduled court appearance, or immediately upon receiving this notification if the time before the scheduled appearance is less than seven (7) days; if you are hearing or voice impaired, call 711.
 DATED this 16 day of Dec, 2013.
 Matthew R. Stubbs, Esq.
 Florida Bar NO. 102871
 Charles A. Muniz, Esquire
 Florida Bar No: 100775
 BUTLER & HOSCH, P.A.
 3185 South Conway Road,
 Suite E
 Orlando, Florida 32812
 Telephone: (407) 381-5200
 Fax: (407) 381-5577
 cm100775@butlerandhosch.com
 FLPlleadings@butlerandhosch.com
 B&H # 319760
 December 20, 27, 2013 13-05952S

FIRST INSERTION

NOTICE OF SALE PURSUANT TO CHAPTER 45 IN THE TWELFTH JUDICIAL CIRCUIT COURT IN AND FOR SARASOTA COUNTY, FLORIDA
 CIVIL DIVISION
CASE NO. 2008 CA 003227 SC
THE BANK OF NEW YORK MELLON F/K/A THE BANK OF NEW YORK, AS TRUSTEE FOR THE HOLDERS OF THE CERTIFICATES, FIRST HORIZON MORTGAGE PASS-THROUGH CERTIFICATES SERIES (FHAMS 2005-FA11), BY FIRST HORIZON HOME LOANS, A DIVISION OF FIRST TENNESSEE BANK NATIONAL ASSOCIATION, MASTER SERVICER, IN ITS CAPACITY AS AGENT FOR THE TRUSTEE UNDER THE POOLING AND SERVICING AGREEMENT Plaintiff, vs. Noemi Campos, et al, Defendants/
 NOTICE IS HEREBY GIVEN pursuant to an Order or Final Judgment of Foreclosure dated October 21, 2013, and entered in Case No. 2008 CA 003227 SC of the Circuit Court of the Twelfth Judicial Circuit in and for Sarasota County, Florida, wherein THE BANK OF NEW YORK MELLON F/K/A THE BANK OF NEW YORK, AS TRUSTEE FOR THE HOLDERS OF THE CERTIFICATES, FIRST HORIZON MORTGAGE PASS-THROUGH CERTIFICATES SERIES (FHAMS 2005-FA11), BY FIRST HORIZON HOME LOANS, A DIVISION OF FIRST TENNESSEE BANK NATIONAL ASSOCIATION, MASTER SERVICER, IN ITS CAPACITY AS AGENT FOR THE TRUSTEE UNDER THE POOLING AND SERVICING AGREEMENT is the Plaintiff and Noemi Campos, Jesse G. Campos, Mortgage Electronic Registration Systems, Inc., John Doe, Jane Doe, the Defendants, I will sell to the highest and best bidder for cash www.sarasota.

FIRST INSERTION

realforeclose.com, the Clerk's website for on-line auctions at 09:00 a.m. on the January 8, 2014, the following described property as set forth in said Order of Final Judgment, to wit:
 Lot 16, Block 452, Ninth Addition To Port Charlotte Subdivision, According To The Plat Thereof As Recorded In Plat Book 12, Pages 21, 21A Through 21S, Of The Public Records Of Sarasota County, Florida.
 IF YOU ARE A PERSON CLAIMING A RIGHT TO FUNDS REMAINING AFTER THE SALE, YOU MUST FILE A CLAIM WITH THE CLERK OF COURT NO LATER THAN 60 DAYS AFTER THE SALE. IF YOU FAIL TO FILE A CLAIM, YOU WILL NOT BE ENTITLED TO ANY REMAINING FUNDS. AFTER 60 DAYS, ONLY THE OWNER OF RECORD AS OF THE DATE OF THE LIS PENDENS MAY CLAIM THE SURPLUS.
 If you are a person with a disability who needs any accommodation in order to participate in this proceeding, you are entitled, at no cost to you, to the provision of certain assistance. Please contact the Sarasota County Jury Office, P.O. Box 3079, Sarasota, Florida 34230-3079, (941)861-7400, at least seven (7) days before your scheduled court appearance, or immediately upon receiving this notification if the time before the scheduled appearance is less than seven (7) days; if you are hearing or voice impaired, call 711.
 DATED at Sarasota County, Florida, this 9th day of Dec., 2013.
 By: Kalei McElroy Blair, Esq.,
 Florida Bar #44613
 GILBERT GARCIA GROUP, P.A.,
 Attorney for Plaintiff(s)
 2005 PAN AM CIRCLE, SUITE 110
 TAMPA, FL 33607
 Phone: (813) 443-5087
 Fax: (813) 443-5089
 emailservice@gilbertgroup.com
 469549.0166/nls
 December 20, 27, 2013 13-05894S

FIRST INSERTION

NOTICE OF FORECLOSURE SALE IN THE CIRCUIT COURT OF THE 12th JUDICIAL CIRCUIT, IN AND FOR SARASOTA COUNTY, FLORIDA
 GENERAL JURISDICTION DIVISION
CASE NO. 58-2010-CA-002150-NC
US BANK NATIONAL ASSOCIATION AS TRUSTEE, PLAINTIFF, VS. BRIAN MILLER, ET AL., DEFENDANT(S).
 NOTICE IS HEREBY GIVEN pursuant to a Final Judgment of Foreclosure dated December 5, 2013 and entered in Case No. 58-2010-CA-002150-NC in the Circuit Court of the 12th Judicial Circuit in and for Sarasota County, Florida wherein US BANK NATIONAL ASSOCIATION AS TRUSTEE is the Plaintiff and BRIAN MILLER, ET AL. the Defendant(s), that the Clerk will sell to the highest and best bidder for cash, by electronic sale beginning at 9:00 a.m. on the prescribed date at www.sarasota.realforeclose.com on the 13th day of January, 2014, the following described property as set forth in said Final Judgment:
 LOT 32, OF THE UNRECORDED PLAT OF MYAKKA RIVER TRAILS, AS RECORDED IN MISCELLANEOUS PLAT BOOK 1, PAGE 6, 6A THROUGH 6E, INCLUSIVE, PUBLIC RECORDS OF SARASOTA COUNTY, FLORIDA.
 A PARCEL OF LAND LYING IN SECTIONS 33 AND 34, TOWNSHIP 39 SOUTH, RANGE 20 EAST, SARASOTA COUNTY, FLORIDA, DESCRIBED AS FOLLOWS:
 COMMENCE AT THE SOUTH-EAST CORNER OF SECTION 28, TOWNSHIP 39 SOUTH, RANGE 20 EAST; THENCE NORTH 89° 46' 36" WEST, ALONG THE SOUTH LINE OF SAID SECTION 28, A DISTANCE

FIRST INSERTION

OF 967.38 FEET, TO A POINT ON THE EASTERLY RIGHT OF WAY LINE OF WEST RIVER ROAD (STATE ROAD NO. 777-100 FEET WIDE RIGHT OF WAY); THENCE SOUTH 36° 47' 47" EAST, ALONG SAID EASTERLY RIGHT OF WAY LINE A DISTANCE OF 647.92 FEET TO THE POINT OF BEGINNING; THENCE NORTH 53° 12' 13" EAST A DISTANCE OF 1479.32 FEET; THENCE SOUTH 36° 47' 47" EAST, A DISTANCE OF 290.89 FEET; THENCE SOUTH 55° 01' 10" WEST, A DISTANCE OF 1480.06 FEET, TO A POINT OF SAID EASTERLY RIGHT OF WAY LINE OF WEST RIVER ROAD; THENCE NORTH 36° 47' 47" WEST ALONG SAID EASTERLY RIGHT OF WAY LINE, A DISTANCE OF 243.99 FEET TO THE POINT OF BEGINNING.
 LESS AND EXCEPT:
 LOT 32A OF THE UNRECORDED PLAT OF MYAKKA RIVER TRAILS, AS RECORDED IN MISCELLANEOUS PLAT BOOK 1, PAGES 6A THROUGH 6E, INCLUSIVE, PUBLIC RECORDS OF SARASOTA COUNTY, FLORIDA.
 A PARCEL OF LAND LYING IN SECTIONS 27 AND 34, TOWNSHIP 39 SOUTH, RANGE 20 EAST, SARASOTA COUNTY, FLORIDA DESCRIBED AS FOLLOWS:
 COMMENCE A THE SOUTH-EAST CORNER OF SECTION 28, TOWNSHIP 39 SOUTH, RANGE 20 EAST; THENCE NORTH 89° 46' 36" WEST, ALONG THE SOUTH LINE OF SAID SECTION 28, A DISTANCE OF 967.38 FEET, TO A POINT ON THE EASTERLY

FIRST INSERTION

RIGHT OF WAY LINE OF WEST RIVER ROAD/STATE ROAD NO. 777-100 FEET WIDE RIGHT OF WAY); THENCE SOUTH 36° 47' 47" EAST, ALONG SAID EASTERLY RIGHT OF WAY LINE A DISTANCE OF 647.92 FEET; THENCE NORTH 53° 12' 13" EAST, A DISTANCE OF 786.27 FEET TO THE POINT OF BEGINNING; THENCE CONTINUOUS NORTH 53° 12' 13" EAST, A DISTANCE OF 693.04 FEET; THENCE SOUTH 36° 47' 47" EAST, A DISTANCE OF 290.89 FEET; THENCE SOUTH 55° 01' 10" WEST, A DISTANCE OF 18.92 FEET TO THE POINT OF CURVATURE OF A CURVE TO THE LEFT HAVING A RADIUS OF 345.36 FEET, A CENTRAL ANGLE OF 4° 37' 42", A CHORD BEARING OF SOUTH 68° 17' 26" WEST, AND A CHORD LENGTH OF 27.89 FEET, THENCE ALONG THE ARC OF SAID CURVE, AN ARC LENGTH OF 27.90 FEET TO THE POINT OF TANGENCY OF SAID CURVE; THENCE SOUTH 65° 58' 35" WEST, A DISTANCE OF 252.28 FEET TO THE POINT OF CURVATURE OF A CURVE TO THE LEFT HAVING A RADIUS OF 470.00 FEET, A CENTRAL ANGLE OF 12° 21' 14", A CHORD BEARING OF SOUTH 59° 47' 58" WEST, AND A CHORD LENGTH OF 101.14 FEET; THENCE ALONG THE ARC OF SAID CURVE, AN ARC LENGTH OF 101.34 FEET TO THE POINT OF REVERSE CURVATURE OF A CURVE TO THE RIGHT HAVING A RADIUS OF 185.06 FEET, A CENTRAL ANGLE OF 42° 55' 16", A CHORD BEARING OF SOUTH 75° 05' 00" WEST, AND A CHORD LENGTH OF 135.41 FEET; THENCE ALONG

FIRST INSERTION

THE ARC OF SAID CURVE, AN ARC LENGTH OF 138.63 FEET TO THE POINT OF TANGENCY OF SAID CURVE; THENCE NORTH 83° 27' 22" WEST, A DISTANCE OF 240.67 FEET TO THE POINT OF BEGINNING.
 COMMONLY KNOWN AS: 370 N. RIVER RD., VENICE, FL 34293
 PARCEL NUMBER: 0785-00-1030
 ANY PERSON CLAIMING AN INTEREST IN THE SURPLUS FROM THE SALE, IF ANY, OTHER THAN THE PROPERTY OWNER, AS OF THE DATE OF THE LIS PENDENS, MUST FILE A CLAIM WITHIN SIXTY (60) DAYS AFTER THE SALE.
 If you are a person with a disability who needs any accommodation in order to participate in this proceeding, you are entitled, at no cost to you, to the provision of certain assistance. Please contact the Sarasota County Jury Office, P.O. Box 3079, Sarasota, Florida 34230-3079, (941)861-7400, at least seven (7) days before your scheduled court appearance, or immediately upon receiving this notification if the time before the scheduled appearance is less than seven (7) days; if you are hearing or voice impaired, call 711.
 This 11th day of December, 2013,
 s/Stephen M. Huttman
 Stephen M. Huttman
 Florida Bar # 102673
 Bus. Email: shuttman@penderlaw.com
 Pendergast & Morgan, P.A.
 115 Perimeter Center Place
 South Terraces Suite 1000
 Atlanta, GA 30346
 Telephone: 678-775-0700
 PRIMARY SERVICE:
 flfc@penderlaw.com
 Attorney for Plaintiff
 FAX: 678-381-8548
 10-13965 dgl_fl
 December 20, 27, 2013 13-05898S

FIRST INSERTION

NOTICE OF FORECLOSURE SALE PURSUANT TO CHAPTER 45 IN THE CIRCUIT COURT OF THE TWELFTH JUDICIAL CIRCUIT IN AND FOR SARASOTA COUNTY, FLORIDA

CASE NO. 2012 CA 001069 NC BANK OF AMERICA, N.A., SUCCESSOR BY MERGER TO BAC HOME LOANS SERVICING, L.P., Plaintiff(s), vs. DUC HO; et al., Defendant(s).

NOTICE IS HEREBY GIVEN that Sale will be made pursuant to an Order or Final Summary Judgment. Final Judgment was awarded on September 9, 2013 in Civil Case No.: 2012 CA 001069 NC, of the Circuit Court of the TWELFTH Judicial Circuit in and for SARASOTA County, Florida, wherein, BANK OF AMERICA, N.A., SUCCESSOR BY MERGER TO BAC HOME LOANS SERVICING, LP is the Plaintiff, and, DUC HO; UNKNOWN SPOUSE OF DUC HO N/K/A XUNG PHAM; CHARLESTON PARK HOME OWNERS ASSOCIATION, INC.; JOCKEY CLUB ON NORTH JOCKEY CLUB OF NORTH PORT PROPERTY OWNERS' ASSOCIATION, INC. AND UNKNOWN TENANT(S) IN POSSESSION are Defendants.

The clerk of the court, Karen E. Rushing, will sell to the highest bidder for cash online at www.sarasota.realforeclose.com at 9:00 AM on January 3, 2014, the following described real property as set forth in said Final summary Judgment, to wit:

LOT 9, BLOCK 2626, 52ND ADDITION TO PORT CHARLOTTE SUBDIVISION, ACCORDING TO THE PLAT THEREOF, AS RECORDED IN PLAT BOOK 21, PAGE 13, 13A THROUGH 13NN, INCLUSIVE, OF THE PUBLIC RECORDS OF SARASOTA COUNTY, FLORIDA.

ANY PERSON CLAIMING AN INTEREST IN THE SURPLUS FUNDS FROM THE SALE, IF ANY, OTHER THAN THE PROPERTY OWNER AS OF THE DATE OF THE LIS PENDENS MUST FILE A CLAIM WITHIN 60 DAYS AFTER THE SALE.

If you are a person with a disability who needs any accommodation in order to participate in this proceeding, you are entitled, at no cost to you, to the provision of certain assistance. Please contact the Sarasota County Jury Office, P.O. Box 3079, Sarasota, Florida 34230-3079, (941)861-7400, at least seven (7) days before your scheduled court appearance, or immediately upon receiving this notification if the time before the scheduled appearance is less than seven (7) days; if you are hearing or voice impaired, call 711.

Dated this 09 day of DEC, 2013.
BY: Nalini Singh
Fla. Bar # 43700
Aldridge Connors, LLP
Attorney for Plaintiff(s)
1615 South Congress Avenue,
Suite 200
Delray Beach, FL 33445
Phone: 561.392.6391
Fax: 561.392.6965
Primary E-Mail:
ServiceMail@aclawlp.com
1092-3383
December 13, 20, 2013 13-05887S

FIRST INSERTION

NOTICE OF SALE IN THE CIRCUIT COURT, TWELFTH JUDICIAL CIRCUIT, IN AND FOR SARASOTA COUNTY, FLORIDA

CASE NO.: 2012 CA 006829 NC SUMMITBRIDGE CREDIT INVESTMENTS II LLC, a Delaware limited liability company, Plaintiff, vs. SARASOTA WINE PROPERTIES, LLC, a Florida limited liability company; PHILLIPPI PLAZA LAND CONDOMINIUM ASSOCIATION, INC., a Florida not-for-profit corporation, UNKNOWN TENANT IN POSSESSION OF 1919 SOUTHWOOD STREET, an individual or entity, DORN'S LIQUOR, INCORPORATED, a Florida corporation; WINE WAREHOUSE, LLC, a Florida limited liability company; THOMAS DORN, individually and MELINDA P. DORN, individually, Defendants.

Notice is hereby given that, pursuant to a final judgment of foreclosure in the above-captioned action, the Clerk of Court will sell the property situated in Sarasota County, Florida, described as follows:

Unit 2, PHILLIPPI PLAZA, a Land Condominium, according to the Declaration of Condominium recorded in Official Records Instrument No. 2006179705 and as per Plat thereof recorded in Condominium Book 39, Page 49 of the Public Records of Sarasota County, Florida.

at public sale, in the presence of the Plaintiff, to the highest and best bidder for cash, at www.sarasota.realforeclose.com, on the 13th day of January, 2014, at 9:00 a.m., pursuant to the terms of the Uniform Final Judgment of Mortgage Foreclosure and in accordance with Section 45.031, Florida Statutes. Any person claiming an interest in the surplus from the sale, if any, other than the property owner as of the date of the lis pendens must file a claim within 60 days after the sale.

If you are a person with a disability who needs any accommodation in order to participate in this proceeding, you are entitled, at no cost to you, to the provision of certain assistance. Please contact the Sarasota County Jury Office, P.O. Box 3079, Sarasota, Florida 34230-3079, (941)861-7400, at least seven (7) days before your scheduled court appearance, or immediately upon receiving this notification if the time before the scheduled appearance is less than seven (7) days; if you are hearing or voice impaired, call 711.

Dated this 11th day of December, 2013.

By: James M. Riley
Florida Bar No.: 700411
Gabriel B. Crafton
Florida Bar No.: 58423
ROGERS TOWERS, P.A.
1301 Riverplace Boulevard, Suite 1500
Jacksonville, Florida 32207
Telephone: (904) 398-3911
Facsimile: (904) 396-0663
Primary Email: jriley@rtlaw.com
Secondary Emails:
gcrafton@rtlaw.com
sguest@rtlaw.com
December 20, 27, 2013 13-05901S

FIRST INSERTION

NOTICE OF FORECLOSURE SALE IN THE CIRCUIT COURT OF THE TWELFTH JUDICIAL CIRCUIT IN AND FOR SARASOTA COUNTY, FLORIDA

CIVIL ACTION
CASE NO.: 58-2008-CA-020797-NC DIVISION: A

U.S. BANK NATIONAL ASSOCIATION, AS INDENTURE TRUSTEE OF THE HOMEBANC MORTGAGE TRUST 2005-3, Plaintiff, vs. TAT K. CHEUNG, et al, Defendant(s).

NOTICE IS HEREBY GIVEN pursuant to a Final Judgment of Mortgage Foreclosure dated November 19, 2013 and entered in Case No. 58-2008-CA-020797-NC of the Circuit Court of the TWELFTH Judicial Circuit in and for SARASOTA County, Florida wherein U.S. BANK NATIONAL ASSOCIATION, AS INDENTURE TRUSTEE OF THE HOMEBANC MORTGAGE TRUST 2005-3 is the Plaintiff and TAT K CHEUNG; FUEY K CHEUNG; HOMEBANC MORTGAGE CORPORATION; VILLAGIO CONDOMINIUM ASSOCIATION, INC.; are the Defendants, The Clerk will sell to the highest and best bidder for cash at WWW.SARASOTA.REALFORECLOSE.COM at 9:00AM, on the 12th day of March, 2014, the following described property as set forth in said Final Judgment:

CONDOMINIUM UNIT 208, BUILDING 15, VILLAGIO CONDOMINIUM, A CONDOMINIUM ACCORDING TO THE DECLARATION OF CONDOMINIUM RECORDED IN OFFICIAL RECORDS INSTRUMENT NO. 2003257048 CONSISTING OF 206 PAGES, AND AMENDMENTS THERETO, IF ANY, OF THE PUBLIC RECORDS OF SARASOTA COUNTY, FLORIDA

A/K/A 1120 VILLAGIO CIRCLE, SARASOTA, FL 34237

Any person claiming an interest in the surplus from the sale, if any, other than the property owner as of the date of the Lis Pendens must file a claim within sixty (60) days after the sale.

If you are a person with a disability who needs any accommodation in order to participate in this proceeding, you are entitled, at no cost to you, to the provision of certain assistance. Please contact the Sarasota County Jury Office, P.O. Box 3079, Sarasota, Florida 34230-3079, (941)861-7400, at least seven (7) days before your scheduled court appearance, or immediately upon receiving this notification if the time before the scheduled appearance is less than seven (7) days; if you are hearing or voice impaired, call 711.

By: Brandon Szymula
Florida Bar No. 98803
Ronald R Wolfe & Associates, P.L.
P.O. Box 25018
Tampa, Florida 33622-5018
(813) 251-4766
(813) 251-1541 Fax
F0811891
December 20, 27, 2013 13-05910S

FIRST INSERTION

NOTICE OF FORECLOSURE SALE IN THE CIRCUIT COURT OF THE TWELFTH JUDICIAL CIRCUIT IN AND FOR SARASOTA COUNTY, FLORIDA

CIVIL ACTION
CASE NO.: 58-2012-CA-006260 NC DIVISION: A

METLIFE HOME LOANS, A DIVISION OF METLIFE BANK, N.A., Plaintiff, vs. CAROLYN ARCHER A/K/A CAROLYN V. ARCHER, et al, Defendant(s).

NOTICE IS HEREBY GIVEN pursuant to a Final Judgment of Mortgage Foreclosure dated December 4, 2013 and entered in Case No. 58-2012-CA-006260 NC of the Circuit Court of the TWELFTH Judicial Circuit in and for SARASOTA County, Florida wherein FIRST HORIZON HOME LOANS A DIVISION OF FIRST TENNESSEE BANK NATIONAL ASSOCIATION (Plaintiff name has changed pursuant to order previously entered.), is the Plaintiff and CAROLYN ARCHER A/K/A CAROLYN V. ARCHER; DEVIN ARCHER A/K/A DEVIN C. ARCHER; DANIELLE C ARCHER; HSBC BANK NEVADA, N.A., AS SUCCESSOR IN INTEREST TO DIRECT MERCHANTS CREDIT CARD BANK, N.A.; COVINGTON PLACE HOMEOWNERS' ASSOCIATION, INC.; are the Defendants, The Clerk will sell to the highest and best bidder for cash at WWW.SARASOTA.REALFORECLOSE.COM at 9:00AM, on the 6th day of March, 2014, the following described property as set forth in said Final Judgment:

LOT 60, COVINGTON PLACE, UNIT 1, ACCORDING TO THE PLAT THEREOF, RECORDED IN PLAT BOOK 41, PAGE(S) 22 AND 22A, OF THE PUBLIC RECORDS OF SARASOTA COUNTY, FLORIDA.

A/K/A 5670 OAKSHIRE AVENUE, SARASOTA, FL 34233

Any person claiming an interest in the surplus from the sale, if any, other than the property owner as of the date of the Lis Pendens must file a claim within sixty (60) days after the sale.

If you are a person with a disability who needs any accommodation in order to participate in this proceeding, you are entitled, at no cost to you, to the provision of certain assistance. Please contact the Sarasota County Jury Office, P.O. Box 3079, Sarasota, Florida 34230-3079, (941)861-7400, at least seven (7) days before your scheduled court appearance, or immediately upon receiving this notification if the time before the scheduled appearance is less than seven (7) days; if you are hearing or voice impaired, call 711.

By: Lisa M. Lewis
Florida Bar No. 0086178
Ronald R Wolfe & Associates, P.L.
P.O. Box 25018
Tampa, Florida 33622-5018
(813) 251-4766
(813) 251-1541 Fax
F12005191
December 20, 27, 2013 13-05909S

FIRST INSERTION

NOTICE OF SALE IN THE CIRCUIT COURT OF THE TWELFTH JUDICIAL CIRCUIT IN AND FOR SARASOTA COUNTY, FLORIDA

CIVIL DIVISION
Case #: 58-2012-CA-000683-NC DIVISION: C

Bank of America, National Association, Successor by Merger to BAC Home Loans Servicing, L.P. f/k/a Countrywide Home Loans Servicing, L.P.

Plaintiff, vs.- Michael L. Shannon a/k/a Michael Shannon; Shanon Stafford-Shannon a/k/a Shanon Stafford; Bank of America, National Association; Oak Ford Owners Association, Inc. Defendant(s).

NOTICE IS HEREBY GIVEN pursuant to an Order dated September 12, 2013, entered in Civil Case No. 2012-CA-000683-NC of the Circuit Court of the 12th Judicial Circuit in and for Sarasota County, Florida, wherein Bank of America, National Association, Successor by Merger to BAC Home Loans Servicing, L.P. f/k/a Countrywide Home Loans Servicing, L.P., Plaintiff and Michael L. Shannon a/k/a Michael Shannon are defendant(s), I, Clerk of Court, Karen E. Rushing, will sell to the highest and best bidder for cash VIA THE INTERNET AT WWW.SARASOTA.REALFORECLOSE.COM, AT 9:00 A.M. on January 10, 2014, the following described property as set forth in said Final Judgment, to-wit:

LOT 10, OAK FORD, PHASE 1, AS PER PLAT THEREOF, RECORDED IN PLAT BOOK 31, PAGE 5, 5A THROUGH 5P, OF THE PUBLIC RECORDS OF SARASOTA COUNTY, FLORIDA.

ANY PERSON CLAIMING AN INTEREST IN THE SURPLUS FROM THE SALE, IF ANY, OTHER THAN THE PROPERTY OWNER AS OF THE DATE OF THE LIS PENDENS MUST FILE A CLAIM WITHIN 60 DAYS AFTER THE SALE.

If you are a person with a disability who needs any accommodation in order to participate in this proceeding, you are entitled, at no cost to you, to the provision of certain assistance. Please contact the Sarasota County Jury Office, P.O. Box 3079, Sarasota, Florida 34230-3079, (941)861-7400, at least seven (7) days before your scheduled court appearance, or immediately upon receiving this notification if the time before the scheduled appearance is less than seven (7) days; if you are hearing or voice impaired, call 711.

Submitted By:
ATTORNEY FOR PLAINTIFF:
SHAPIRO, FISHMAN & GACHÉ, LLP
2424 North Federal Highway, Suite 360
Boca Raton, Florida 33431
December 20, 27, 2013 13-05904S

FIRST INSERTION

NOTICE OF ACTION IN THE CIRCUIT COURT OF THE TWELFTH JUDICIAL CIRCUIT IN AND FOR SARASOTA COUNTY, FLORIDA

CASE NO.: 2013 CA 007489 NC HSBC BANK USA, NATIONAL ASSOCIATION, AS TRUSTEE, IN TRUST FOR THE REGISTERED HOLDERS OF ACE SECURITIES CORP., HOME EQUITY LOAN TRUST, SERIES 2006-FM2, ASSET BACKED PASS-THROUGH CERTIFICATES, Plaintiff, VS. DONALD CAPUANO; et al., Defendant(s).

TO: Donald Capuano
Unknown Spouse of Donald Capuano
Last Known Residence: 8591 Seville Court, North Port, FL 34287

YOU ARE HEREBY NOTIFIED that an action to foreclose a mortgage on the following property in SARASOTA County, Florida:

LOT 23, BLOCK 937, SECOND REPLAT IN FIFTEENTH ADDITION TO PORT CHARLOTTE SUBDIVISION, A SUBDIVISION ACCORDING TO THE PLAT THEREOF, AS RECORDED IN PLAT BOOK 19, PAGES 3, 3A TO 3C, INCLUSIVE, OF THE PUBLIC RECORDS OF SARASOTA COUNTY, FLORIDA.

has been filed against you and you are required to serve a copy of your written defenses, if any, to it on ALDRIDGE | CONNORS, LLP, Plaintiff's attorney, at 1615 South Congress Avenue, Suite 200, Delray Beach, FL 33445 (Phone Number: (561) 392-6391), within 30 days of the first date of publication of this notice, and file the original with the clerk of this court either before 1-20-2014 on Plaintiff's attorney or immediately thereafter; otherwise a default will be entered against you for the relief demanded in the complaint or petition.

If you are a person with a disability who needs any accommodation in order to participate in this proceeding, you are entitled, at no cost to you, to the provision of certain assistance. Please contact the Sarasota County Jury Office, P.O. Box 3079, Sarasota, Florida 34230-3079, (941)861-7400, at least seven (7) days before your scheduled court appearance, or immediately upon receiving this notification if the time before the scheduled appearance is less than seven (7) days; if you are hearing or voice impaired, call 711.

Dated on December 12, 2013.

KAREN E. RUSHING
As Clerk of the Court
(SEAL) By: G. Kopinsky
As Deputy Clerk

ALDRIDGE | CONNORS, LLP
Plaintiff's Attorney
1615 South Congress Avenue,
Suite 200
Delray Beach, FL 33445
Phone Number: (561) 392-6391
1012-1341B
December 20, 27, 2013 13-05916S

FIRST INSERTION

NOTICE OF RESCHEDULED FORECLOSURE SALE IN THE CIRCUIT COURT OF THE TWELFTH JUDICIAL CIRCUIT IN AND FOR SARASOTA COUNTY, FLORIDA

CIVIL ACTION
CASE NO.: 58-2010 CA 008108 NC DIVISION: C

WELLS FARGO BANK, NA, Plaintiff, vs. THE UNKNOWN TRUSTEE OF THE KELELA HOLDING TRUST DATED NOV 7, 2007, et al, Defendant(s).

NOTICE IS HEREBY GIVEN pursuant to an Order Rescheduling Foreclosure Sale dated December 4, 2013 and entered in Case NO. 58-2010 CA 008108 NC of the Circuit Court of the TWELFTH Judicial Circuit in and for SARASOTA County, Florida wherein WELLS FARGO BANK, NA, is the Plaintiff and THE UNKNOWN TRUSTEE OF THE KELELA HOLDING TRUST DATED NOV 7, 2007; CHERYL HIRSCH A/K/A CHERYL E. HIRSCH; ANY AND ALL UNKNOWN PARTIES CLAIMING BY, THROUGH, UNDER, AND AGAINST THE HEREIN NAMED INDIVIDUAL DEFENDANT(S) WHO ARE NOT KNOWN TO BE DEAD OR ALIVE, WHETHER SAID UNKNOWN PARTIES MAY CLAIM AN INTEREST AS SPOUSE, HEIRS, DEVISEES, GRANTEEES, OR OTHER CLAIMANTS; are the Defendants, The Clerk will sell to the highest and best bidder for cash at WWW.SARASOTA.REALFORECLOSE.COM at 9:00AM, on 01/09/2014, the following

described property as set forth in said Final Judgment:

LOT 4, IN BLOCK 2412, FORTY-NINTH ADDITION TO PORT CHARLOTTE SUBDIVISION, ACCORDING TO THE PLAT THEREOF, AS RECORDED IN PLAT BOOK 21, AT PAGES 1, 1A THROUGH 1TT, INCLUSIVE, OF THE PUBLIC RECORDS OF SARASOTA COUNTY, FLORIDA

A/K/A 1520 GAUGUIN STREET, NORTHPORT, FL 34288

Any person claiming an interest in the surplus from the sale, if any, other than the property owner as of the date of the Lis Pendens must file a claim within sixty (60) days after the sale.

If you are a person with a disability who needs any accommodation in order to participate in this proceeding, you are entitled, at no cost to you, to the provision of certain assistance. Please contact the Sarasota County Jury Office, P.O. Box 3079, Sarasota, Florida 34230-3079, (941)861-7400, at least seven (7) days before your scheduled court appearance, or immediately upon receiving this notification if the time before the scheduled appearance is less than seven (7) days; if you are hearing or voice impaired, call 711.

By: Luke Kiel
Florida Bar No. 98631
Ronald R Wolfe & Associates, P.L.
P.O. Box 25018
Tampa, Florida 33622-5018
(813) 251-4766
(813) 251-1541 Fax
F10050765
December 20, 27, 2013 13-05926S

FIRST INSERTION

NOTICE OF FORECLOSURE SALE IN THE CIRCUIT COURT OF THE TWELFTH JUDICIAL CIRCUIT IN AND FOR SARASOTA COUNTY, FLORIDA

CIVIL DIVISION
CASE NO.: 58-2009-CA-017132NC AURORA LOAN SERVICES, LLC Plaintiff, v. WILLIAM, GRIFFIN; ET. AL, Defendants,

NOTICE IS HEREBY GIVEN pursuant to a Final Judgment dated June 10, 2013, entered in Civil Case No.: 58-2009-CA-017132NC, of the Circuit Court of the TWELFTH Judicial Circuit in and for Sarasota County, Florida, wherein AURORA LOAN SERVICES, LLC is Plaintiff, and WILLIAM D. GRIFFIN; CARLA GRIFFIN; ANY AND ALL UNKNOWN PARTIES CLAIMING BY, THROUGH, UNDER, AND AGAINST THE HEREIN NAMED INDIVIDUAL DEFENDANT(S) WHO ARE NOT KNOWN TO BE DEAD OR ALIVE, WHETHER SAID UNKNOWN PARTIES MAY CLAIM AN INTEREST AS SPOUSES, HEIRS, DEVISEES, GRANTEEES OR OTHER CLAIMANTS; MORTGAGE ELECTRONIC REGISTRATION SYSTEMS, INC.; JOHN DOE AND JANE DOE AS UNKNOWN TENANTS IN POSSESSION, are Defendant(s).

KAREN E. RUSHING, the Clerk of Court shall sell to the highest bidder for cash online at Www.Sarasota.Realforeclose.Com at 9:00 a.m. on the 6th day of January, 2014 the following described real property as set forth in said Final Judgment, to wit:

LOT 6, FIDDLER BAYOU SUBDIVISION, AS PER PLAT THEREOF RECORDED IN PLAT BOOK 4, PAGE 91, OF THE PUBLIC RECORDS OF SARASOTA COUNTY, FLORIDA.

ALSO AN UNDIVIDED

1/5TH INTEREST IN AND TO LOT 10, ALSO REFERRED TO AS COMMUNITY LOT 10 OF FIDDLER BAYOU SUBDIVISION, AS PER PLAT THEREOF RECORDED IN PLAT BOOK 4, PAGE 91, OF THE PUBLIC RECORDS OF SARASOTA COUNTY, FLORIDA.

If you are a person claiming a right to funds remaining after the sale, you must file a claim with the clerk no later than 60 days after the sale. If you fail to file a claim you will not be entitled to any remaining funds. After 60 days, only the owner of record as of the date of the lis pendens may claim the surplus.

If you are a person with a disability who needs any accommodation in order to participate in this proceeding, you are entitled, at no cost to you, to the provision of certain assistance. Please contact the Sarasota County Jury Office, P.O. Box 3079, Sarasota, Florida 34230-3079, (941)861-7400, at least seven (7) days before your scheduled court appearance, or immediately upon receiving this notification if the time before the scheduled appearance is less than seven (7) days; if you are hearing or voice impaired, call 711.

Dated this 11 day of Dec, 2013.
/s/ Melody A. Martinez FBN 124151
for By: Joshua Sabet, Esquire
Fla. Bar No.: 85356
Primary Email: JSabet@ErwLaw.com
Secondary Email:
docservice@erwlaw.com
Attorney for Plaintiff:
Elizabeth R. Wellborn, P.A.
350 Jim Moran Blvd.
Suite 100 Deerfield
Beach, FL 33442
Telephone: (954) 354-3544
Facsimile: (954) 354-3545
FILE # 1137ST-40746
December 20, 27, 2013 13-05902S

FIRST INSERTION

NOTICE OF ACTION IN THE CIRCUIT COURT OF THE TWELFTH JUDICIAL CIRCUIT IN AND FOR SARASOTA COUNTY, FLORIDA

CIVIL ACTION
CASE NO.: 58-2013-CA-001515 NC DIVISION: A

US BANK NATIONAL ASSOCIATION, AS TRUSTEE FOR ADJUSTABLE RATE MORTGAGE TRUST 2006-2, ADJUSTABLE RATE MORTGAGE BACKED PASS THROUGH CERTIFICATES, SERIES 2006-2, Plaintiff, vs. CHRISTOPHER NOWAK, et al, Defendant(s).

To: CHRISTOPHER NOWAK
Last Known Address: 3465 Gulf of Mexico Dr
Longboat Key, FL 34228
Current Address: Unknown

ANY AND ALL UNKNOWN PARTIES CLAIMING BY, THROUGH, UNDER, AND AGAINST THE HEREIN NAMED INDIVIDUAL DEFENDANT(S) WHO ARE NOT KNOWN TO BE DEAD OR ALIVE, WHETHER SAID UNKNOWN PARTIES MAY CLAIM AN INTEREST AS SPOUSES, HEIRS, DEVISEES, GRANTEEES, OR OTHER CLAIMANTS
Last Known Address: Unknown
Current Address: Unknown

YOU ARE NOTIFIED that an action to foreclose a mortgage on the following property in Sarasota County, Florida:

UNIT 103, THE BEACH AT LONGBOAT KEY, A CONDOMINIUM TOGETHER WITH AN UNDIVIDED INTEREST IN THE COMMON ELEMENTS APPURTENANT THERETO, ACCORDING TO THE DECLARATION OF CONDOMINIUM RECORDED IN OFFICIAL RECORDS #2006006750 AND AMENDMENTS THERETO, AND AS PER PLAT

THEREOF, RECORDED IN CONDOMINIUM BOOK 38, PAGE 48-481, AND AMENDMENTS THERETO, OF THE PUBLIC RECORDS OF SARASOTA COUNTY, FLORIDA.

A/K/A 3465 GULF OF MEXICO DR # 103 LONGBOAT KEY FL 34228-2827

has been filed against you and you are required to serve a copy of your written defenses within 30 days after the first publication, if any, on Albertelli Law, Plaintiff's attorney, whose address is P.O. Box 23028, Tampa, FL 33623, and file the original with this Court either before 01/20/14 service on Plaintiff's attorney, or immediately thereafter; otherwise, a default will be entered against you for the relief demanded in the Complaint or petition.

This notice shall be published once a week for two consecutive weeks in the Business Observer.

If you are a person with a disability who needs any accommodation in order to participate in this proceeding, you are entitled, at no cost to you, to the provision of certain assistance. Please contact the Sarasota County Jury Office, P.O. Box 3079, Sarasota, Florida 34230-3079, (941)861-7400, at least seven (7) days before your scheduled court appearance, or immediately upon receiving this notification if the time before the scheduled appearance is less than seven (7) days; if you are hearing or voice impaired, call 711.

WITNESS my hand and the seal of this court on this 6 day of December, 2013.

KAREN E. RUSHING, CLERK
Clerk of the Circuit Court
(SEAL) By: K. Goodspeed
Deputy Clerk

Albertelli Law
P.O. Box 23028
Tampa, FL 33623
PH -010340F01
December 20, 27, 2013 13-05938S

FIRST INSERTION

NOTICE OF FORECLOSURE SALE IN THE CIRCUIT COURT OF THE TWELFTH JUDICIAL CIRCUIT IN AND FOR SARASOTA COUNTY, FLORIDA GENERAL JURISDICTION DIVISION

CASE NO. 2008 CA 018277 NC
NATIONSTAR MORTGAGE, LLC,
Plaintiff, vs.
CHRISTOPHER J. FRITZ,
MORTGAGE ELECTRONIC
REGISTRATION SYSTEMS, INC.,
AS NOMINEE FOR AMERICA'S
WHOLESALE LENDER, JANE
DOE, JOHN DOE, UNKNOWN
SPOUSE OF CHRISTOPHER J.
FRITZ,
Defendants.

NOTICE IS HEREBY GIVEN pursuant to a Summary Final Judgment of Foreclosure entered November 19, 2013 in Civil Case No. 2008 CA 018277 NC of the Circuit Court of the TWELFTH Judicial Circuit in and for Sarasota County, Florida, wherein NATIONSTAR MORTGAGE, LLC is Plaintiff and CHRISTOPHER J. FRITZ, MORTGAGE ELECTRONIC REGISTRATION SYSTEMS, INC., AS NOMINEE FOR AMERICA'S WHOLESALE LENDER, JANE DOE, JOHN DOE, UNKNOWN SPOUSE OF CHRISTOPHER J. FRITZ, are Defendants, the Clerk of Court will sell to the highest and best bidder for cash electronically at www.sarasota.realforeclose.com in accordance with Chapter 45, Florida Statutes on the 10th day of January, 2014 at 09:00 AM on the following described property as set forth in said Summary Final Judgment, to-wit:

Lot 9, Block 2530, 51ST ADDITION TO PORT CHARLOTTE SUBDIVISION, a Subdivision according to the plat thereof, as recorded in Plat Book 21 at pages 8, 8A through 8GG of the Public Records of Sarasota County, Florida.

Any person claiming an interest in the surplus from the sale, if any, other than the property owner as of the date of the lis pendens, must file a claim within 60 days after the sale.

If you are a person with a disability who needs any accommodation in order to participate in this proceeding, you are entitled, at no cost to you, to the provision of certain assistance. Please contact the Sarasota County Jury Office, P.O. Box 3079, Sarasota, Florida 34230-3079, (941)861-7400, at least seven (7) days before your scheduled court appearance, or immediately upon receiving this notification if the time before the scheduled appearance is less than seven (7) days; if you are hearing or voice impaired, call 711.

H. Michael Solloa, Esq.
 Florida Bar No. 37854
 for Andrew L. Denzer, Esq.

McCalla Raymer, LLC
 Attorney for Plaintiff
 225 E. Robinson St. Suite 660
 Orlando, FL 32801
 Phone: (407) 674-1850
 Fax: (321) 248-0420
 Email:
 MRService@mcallaraymer.com
 Fla. Bar No.: 72496
 2210205
 10-01016-5
 December 20, 27, 2013 13-05920S

FIRST INSERTION

NOTICE OF SALE IN THE CIRCUIT COURT OF THE TWELFTH JUDICIAL CIRCUIT IN AND FOR SARASOTA COUNTY, FLORIDA

CASE NO. 2011 CA 003719 NC
U.S. BANK, N.A.
Plaintiff, v.
JORGE R. BROCEA DIAZ;
CARMEN L. ALVAREZ;
UNKNOWN TENANT 1;
UNKNOWN TENANT 2; AND ALL
UNKNOWN PARTIES CLAIMING
BY, THROUGH, UNDER OR
AGAINST THE ABOVE NAMED
DEFENDANT(S), WHO
(IS/ARE) NOT KNOWN TO BE
DEAD OR ALIVE, WHETHER
SAID UNKNOWN PARTIES
CLAIM AS HEIRS, DEVISEES,
GRANTEES, ASSIGNEES,
LIENORS, CREDITORS,
TRUSTEES, SPOUSES, OR OTHER
CLAIMANTS; FLORIDA HOUSING
FINANCE CORPORATION
Defendants.

Notice is hereby given that, pursuant to the Summary Final Judgment of Foreclosure entered on October 15, 2013, and the Order Rescheduling Foreclosure Sale entered on December 2, 2013, in this cause, in the Circuit Court of Sarasota County, Florida, the clerk shall sell the property situated in Sarasota County, Florida, described as:

LOT 8, BLOCK 3, EASTWOOD OAKS, UNIT NO. 4, ACCORDING TO THE PLAT THEREOF AS RECORDED IN PLAT BOOK 12, PAGE 25, OF THE PUBLIC RECORDS OF SARASOTA COUNTY, FLORIDA.

a/k/a 239 HOOSIER PLACE, SARASOTA, FL 34232

at public sale, to the highest and best bidder, for cash, online at www.sarasota.realforeclose.com, on January 7, 2014 beginning at 09:00 AM.

If you are a person claiming a right to funds remaining after the sale, you must file a claim with the clerk no later than 60 days after the sale. If you fail to file a claim you will not be entitled to any remaining funds.

If you are a person with a disability who needs any accommodation in order to participate in this proceeding, you are entitled, at no cost to you, to the provision of certain assistance. Please contact the Sarasota County Jury Office, P.O. Box 3079, Sarasota, Florida 34230-3079, (941)861-7400, at least seven (7) days before your scheduled court appearance, or immediately upon receiving this notification if the time before the scheduled appearance is less than seven (7) days; if you are hearing or voice impaired, call 711.

Dated at St. Petersburg, Florida, this 9th day of December, 2013.

By: /s/ Angela L. Leiner, Esquire
 Angela L. Leiner
 FBN#85112

Douglas C. Zahm, P.A.
 Designated Email Address:
 efilng@dczahm.com
 12425 28th Street North,
 Suite 200
 St. Petersburg, FL 33716
 Telephone No. (727) 536-4911
 Attorney for the Plaintiff
 66511844
 December 20, 27, 2013 13-05911S

FIRST INSERTION

NOTICE OF SALE IN THE CIRCUIT COURT OF THE TWELFTH JUDICIAL CIRCUIT IN AND FOR SARASOTA COUNTY, FLORIDA

Case No.: 58-2012-CA-004762 NC
BANK OF AMERICA, N.A.
Plaintiff, v.
RAMON J. KIPNES; KAREN
S.L. KIPNES; ANY AND ALL
UNKNOWN PARTIES CLAIMING
BY, THROUGH, UNDER, AND
AGAINST THE HEREIN NAMED
INDIVIDUAL DEFENDANT(S)
WHO ARE NOT KNOWN TO BE
DEAD OR ALIVE, WHETHER
SAID UNKNOWN PARTIES
MAY CLAIM AN INTEREST AS
SPOUSES, HEIRS, DEVISEES,
GRANTEES, OR OTHER
CLAIMANTS; MORTGAGE
ELECTRONIC REGISTRATION
SYSTEMS AS NOMINEE FOR RBS
CITIZENS, N.A.; SILVER OAK
NEIGHBORHOOD ASSOCIATION,
INC.
Defendant(s).

NOTICE IS HEREBY GIVEN pursuant to an Order Resetting Foreclosure Sale dated November 12, 2013, entered in Civil Case No. 58-2012-CA-004762 NC of the Circuit Court of the Twelfth Judicial Circuit in and for Sarasota County, Florida, wherein the Clerk of the Circuit Court will sell to the highest bidder for cash on the 8th day of January, 2014, at 9:00 a.m. online at the website: https://www.sarasota.realforeclose.com, relative to the following described property as set forth in the Final Judgment, to-wit:

LOT 136, SILVER OAK, UNIT 3, ACCORDING TO THE PLAT THEREOF RECORDED IN PLAT BOOK 43, PAGE 18, OF THE PUBLIC RECORDS OF SARASOTA COUNTY, FLORIDA.

Any person claiming an interest in the surplus from the sale, if any, other than the property owner as of the date of the Lis Pendens must file a claim within 60 days after the sale.

If you are a person with a disability who needs any accommodation in order to participate in this proceeding, you are entitled, at no cost to you, to the provision of certain assistance. Please contact the Sarasota County Jury Office, P.O. Box 3079, Sarasota, Florida 34230-3079, (941)861-7400, at least seven (7) days before your scheduled court appearance, or immediately upon receiving this notification if the time before the scheduled appearance is less than seven (7) days; if you are hearing or voice impaired, call 711.

By: Stephen Orsillo, Esq., FBN: 89377
 9409 Philadelphia Road
 Baltimore, Maryland 21237

Mailing Address:
 Morris/Hardwick/Schneider, LLC
 5110 Eisenhower Blvd., Suite 302A
 Tampa, Florida 33634
 Customer Service (866)-503-4930
 MHSinbox@closingsource.net
 96211005
 FL-97001258-12
 December 20, 27, 2013 13-05921S

FIRST INSERTION

NOTICE OF FORECLOSURE SALE IN THE CIRCUIT COURT OF THE 12TH JUDICIAL CIRCUIT, IN AND FOR SARASOTA COUNTY, FLORIDA

CIVIL DIVISION:
CASE NO.: 2012 CA 010478
FEDERAL NATIONAL
MORTGAGE ASSOCIATION,
Plaintiff, vs.
JULIA M ALLIN; JPMORGAN
CHASE BANK, N.A.; MARVIN G
ALLIN; UNKNOWN TENANT IN
POSSESSION OF THE SUBJECT
PROPERTY.
Defendants.

NOTICE IS HEREBY GIVEN pursuant to Final Judgment of Foreclosure dated the 2nd day of December, 2013, and entered in Case No. 2012 CA 010478, of the Circuit Court of the 12TH Judicial Circuit in and for Sarasota County, Florida, wherein FEDERAL NATIONAL MORTGAGE ASSOCIATION is the Plaintiff and JULIA M ALLIN; JPMORGAN CHASE BANK, N.A.; MARVIN G ALLIN and UNKNOWN TENANT(S) IN POSSESSION OF THE SUBJECT PROPERTY are defendants. The Clerk of this Court shall sell to the highest and best bidder for cash electronically at www.sarasota.realforeclose.com at, 9:00 AM on the 8th day of January, 2014, the following described property as set forth in said Final Judgment, to-wit:

LOT 14, BLOCK 12, EAST GATE, UNIT #1, ACCORDING TO THE PLAT THEREOF RECORDED IN PLAT BOOK 9, PAGE 43, OF THE PUBLIC RECORDS OF SARASOTA COUNTY, FLORIDA

ANY PERSON CLAIMING AN INTEREST IN THE SURPLUS FROM THE SALE, IF ANY, OTHER THAN THE PROPERTY OWNER AS OF THE DATE OF THE LIS PENDENS MUST FILE A CLAIM WITHIN 60 DAYS AFTER THE SALE.

If you are a person with a disability who needs any accommodation in order to participate in this proceeding, you are entitled, at no cost to you, to the provision of certain assistance. Please contact the Sarasota County Jury Office, P.O. Box 3079, Sarasota, Florida 34230-3079, (941)861-7400, at least seven (7) days before your scheduled court appearance, or immediately upon receiving this notification if the time before the scheduled appearance is less than seven (7) days; if you are hearing or voice impaired, call 711.

Dated this 13 day of December, 2013.

By: Bruce K. Fay
 Bar #97308

Choice Legal Group, P.A.
 1800 NW 49th Street, Suite 120
 Fort Lauderdale, Florida 33309
 Telephone: (954) 453-0365
 Facsimile: (954) 771-6052
 Toll Free: 1-800-441-2438
 DESIGNATED PRIMARY E-MAIL
 FOR SERVICE PURSUANT TO FLA
 R. JUD. ADMIN 2.516
 eservice@clegalgroup.com
 11-19478
 December 20, 27, 2013 13-05938S

FIRST INSERTION

NOTICE OF SALE IN THE CIRCUIT COURT OF THE TWELFTH JUDICIAL CIRCUIT IN AND FOR SARASOTA COUNTY, FLORIDA

CIVIL DIVISION
Case #: 2011-CA-008562-NC
DIVISION: A
Federal National Mortgage
Association ("FNMA")
Plaintiff, vs.-
Lori A. Knight; Tatum Ridge Owners
Association, Inc.
Defendant(s).

NOTICE IS HEREBY GIVEN pursuant to an Order dated November 6, 2013, entered in Civil Case No. 2011-CA-008562-NC of the Circuit Court of the 12th Judicial Circuit in and for Sarasota County, Florida, wherein Federal National Mortgage Association, Plaintiff and Lori A. Knight are defendant(s), I, Clerk of Court, Karen E. Rushing, will sell to the highest and best bidder for cash VIA THE INTERNET AT WWW.SARASOTA.REALFORECLOSE.COM , AT 9:00 A.M. on January 6, 2014, the following described property as set forth in said Final Judgment, to-wit:

LOT 32, BLOCK J, TATUM RIDGE, ACCORDING TO THE PLAT THEREOF, AS RECORDED IN PLAT BOOK 40, PAGES 49, 49A THROUGH 49J, OF THE PUBLIC RECORDS OF SARASOTA COUNTY, FLORIDA.

ANY PERSON CLAIMING AN INTEREST IN THE SURPLUS FROM THE SALE, IF ANY, OTHER THAN THE PROPERTY OWNER AS OF THE DATE OF THE LIS PENDENS MUST FILE A CLAIM WITHIN 60 DAYS AFTER THE SALE.

If you are a person with a disability who needs any accommodation in order to participate in this proceeding, you are entitled, at no cost to you, to the provision of certain assistance. Please contact the Sarasota County Jury Office, P.O. Box 3079, Sarasota, Florida 34230-3079, (941)861-7400, at least seven (7) days before your scheduled court appearance, or immediately upon receiving this notification if the time before the scheduled appearance is less than seven (7) days; if you are hearing or voice impaired, call 711.

Submitted By:
 ATTORNEY FOR PLAINTIFF:
 SHAPIRO, FISHMAN &
 GACHÉ, LLP
 2424 North Federal Highway, Suite 360
 Boca Raton, Florida 33431
 (561) 998-6700
 (561) 998-6707
 10-197858 FC01 WCC
 December 20, 27, 2013 13-05907S

FIRST INSERTION

NOTICE OF RESCHEDULED SALE IN THE CIRCUIT COURT OF THE TWELFTH JUDICIAL CIRCUIT IN AND FOR SARASOTA COUNTY, FLORIDA

CIVIL ACTION
CASE NO.: 2009-CA-021880
DIVISION: A
CITIMORTGAGE, INC.,
Plaintiff, vs.
LYNDA M. LAUMANN, et al,
Defendant(s).

NOTICE IS HEREBY GIVEN Pursuant to an Order Rescheduling Foreclosure Sale dated December 5, 2013, and entered in Case No. 2009-CA-021880 of the Circuit Court of the Twelfth Judicial Circuit in and for Sarasota County, Florida in which Citimortgage, Inc. is the Plaintiff and Lynda M. Laumann, are defendants, the Sarasota County Clerk of the Circuit Court will sell to the highest and best bidder for cash in/ on the Internet: www.sarasota.realforeclose.com , Sarasota County, Florida at 9:00am on the 23rd day of January, 2014, the following described property as set forth in said Final Judgment of Foreclosure:

LOT 18, BLOCK 2498, 50TH ADDITION TO PORT CHARLOTTE SUBDIVISION, ACCORDING TO THE PLAT THEREOF, RECORDED IN PLAT BOOK 21, PAGES 7, 7A-7H, OF THE PUBLIC RECORDS OF SARASOTA COUNTY, FLORIDA.

A/K/A 5591 KENWOOD DR, NORTH PORT, FL 34287

Any person claiming an interest in the surplus from the sale, if any, other than the property owner as of the date of the Lis Pendens must file a claim within 60 days after the sale.

If you are a person with a disability who needs any accommodation in order to participate in this proceeding, you are entitled, at no cost to you, to the provision of certain assistance. Please contact the Sarasota County Jury Office, P.O. Box 3079, Sarasota, Florida 34230-3079, (941)861-7400, at least seven (7) days before your scheduled court appearance, or immediately upon receiving this notification if the time before the scheduled appearance is less than seven (7) days; if you are hearing or voice impaired, call 711.

Albertelli Law
 Attorney for Plaintiff
 P.O. Box 23028
 Tampa, FL 33623
 (813) 221-4743
 eService: servealaw@albertellilaw.com
 10-62634
 December 20, 27, 2013 13-05936S

FIRST INSERTION

NOTICE OF FORECLOSURE SALE IN THE CIRCUIT COURT OF THE TWELFTH JUDICIAL CIRCUIT IN AND FOR SARASOTA COUNTY, FLORIDA

CIVIL DIVISION
Case No.: 58-2011-CA-008662 NC
Division: A
GMAC MORTGAGE, LLC
Plaintiff, v.
THE UNKNOWN TRUSTEE(S)
OF THE ABBOTT T. KISSEN AND
BETTIE J. KISSEN REVOCABLE
LIVING TRUST; ET AL.
Defendants,

NOTICE IS HEREBY GIVEN pursuant to a Final Judgment dated December 2, 2013, entered in Civil Case No.: 58-2011-CA-008662 NC, DIVISION: A, of the Circuit Court of the TWELFTH Judicial Circuit in and for Sarasota County, Florida, wherein GMAC MORTGAGE, LLC is Plaintiff, and THE UNKNOWN TRUSTEE(S) OF THE ABBOTT T. KISSEN AND BETTIE J. KISSEN REVOCABLE LIVING TRUST; THE UNKNOWN HEIRS AND/OR BENEFICIARIES OF THE ABBOTT T. KISSEN AND BETTIE J. KISSEN REVOCABLE LIVING TRUST; TRICIA MCBEE; DAVID KISSEN; SOUTHBAY YACHT AND RACQUET CLUB OWNERS ASSOCIATION, INC.; UNKNOWN TENANT #1; UNKNOWN TENANT #2; ALL OTHER UNKNOWN PARTIES CLAIMING INTERESTS BY, THROUGH, UNDER, AND AGAINST A NAMED DEFENDANT(S) WHO ARE NOT KNOWN TO BE DEAD OR ALIVE, WHETHER SAME UNKNOWN PARTIES MAY CLAIM AN INTEREST AS SPOUSES, HEIRS, DEVISEES, GRANTEES, OR OTHER CLAIMANTS, are Defendant(s).

KAREN E. RUSHING, the Clerk of Court shall sell to the highest bidder for cash online at www.Sarasota.Realforeclose.Com at 9:00 a.m. on the 6th day of January, 2014 the following described real property as set forth in said Final Summary Judgment, to wit:

BEING LOT 221, SOUTHBAY YACHT AND RACQUET CLUB, A SUBDIVISION, AS PER PLAT THEREOF, RECORDED IN PLAT BOOK 22, PAGES 27 AND 27A THRU 27F, OF THE PUBLIC RECORDS OF SARASOTA COUNTY, FLORIDA.

If you are a person claiming a right to funds remaining after the sale, you must file a claim with the clerk no later than 60 days after the sale. If you fail to file a claim you will not be entitled to any remaining funds. After 60 days, only the owner of record as of the date of the lis pendens may claim the surplus.

If you are a person with a disability who needs any accommodation in this proceeding, you are entitled, at no cost to you, to the provision of certain assistance. Please contact the Sarasota County Jury Office, P.O. Box 3079, Sarasota, Florida 34230-3079, (941)861-7400, at least seven (7) days before your scheduled court appearance, or immediately upon receiving this notification if the time before the scheduled appearance is less than seven (7) days; if you are hearing or voice impaired, call 711.

Dated this 11 day of Dec, 2013.

/s/ Melody A. Martinez FBN 124151
 for By: Joshua Sabet, Esquire
 Fla. Bar No.: 85356
 Primary Email: JSabet@ErwLaw.com
 Secondary Email:
 docservice@erwlaw.com
 Attorney for Plaintiff:
 Elizabeth R. Wellborn, P.A.
 350 Jim Moran Blvd.
 Suite 100 Deerfield
 Beach, FL 33442
 Telephone: (954) 354-3544
 Facsimile: (954) 354-3545
 FILE # 0719ST-29118
 December 20, 27, 2013 13-05908S

FIRST INSERTION

NOTICE OF ACTION IN THE CIRCUIT COURT OF THE TWELFTH JUDICIAL CIRCUIT IN AND FOR SARASOTA COUNTY, FLORIDA

CIVIL DIVISION
CASE NO.: 58-2013-CA-006947 NC
DIVISION: A
FIFTH THIRD MORTGAGE
COMPANY
Plaintiff, v.
TERESA THOMPSON A/K/A
TERESA EVANOFF; UNKNOWN
SPOUSE OF TERESA THOMPSON
A/K/A TERESA EVANOFF; FIFTH
THIRD BANK (SOUTH FLORIDA);
REMODELING SARASOTA, INC.;
CITYSCAPE AT COURTHOUSE
CENTRE CONDOMINIUM
ASSOCIATION, INC.; UNKNOWN
TENANT #1; UNKNOWN TENANT
#2; ALL OTHER UNKNOWN
PARTIES CLAIMING INTERESTS
BY, THROUGH, UNDER,
AND AGAINST A NAMED
DEFENDANT(S) WHO ARE NOT
KNOWN TO BE DEAD OR ALIVE,
WHETHER SAME UNKNOWN
PARTIES MAY CLAIM AN
INTEREST AS SPOUSES, HEIRS,
DEVISEES, GRANTEES, OR
OTHER CLAIMANTS,
Defendant(s),
TO: UNKNOWN TENANT #1
Current Address: 1990 Main Street,
Unit 15
Sarasota, Florida 34236

YOU ARE NOTIFIED that an action to foreclose a mortgage on the following property in Sarasota County, Florida:

UNIT 15, CITYSCAPE AT COURTHOUSE CENTRE, A CONDOMINIUM ACCORDING TO THE DECLARATION OF CONDOMINIUM RECORDED IN OFFICIAL RECORDS #2005085395, AND AMENDMENTS THERETO AS PER PLAT THEREOF RECORDED IN CONDOMINIUM BOOK 37 PAGE 36 AND AMENDMENTS THERETO OF THE PUBLIC RECORDS OF SARASOTA COUNTY, FLORIDA.

This property is located at the Street address of: 1990 Main Street, Unit 15, Sarasota, Florida 34236

YOU ARE REQUIRED to serve a copy of your written defenses on or before 1-20-2014 a date which is within 30 days after the first publication, if any, on Elizabeth R. Wellborn, P.A., Plaintiff's Attorney, whose address is 350 Jim Moran Blvd., Suite 100, Deerfield Beach, Florida 33442, and file the original with this Court either before service on Plaintiff's Attorney, or immediately thereafter; otherwise, a default will be entered against you for the relief demanded in the Complaint or Petition.

This Notice shall be published once a week for two consecutive weeks in The Business Observer.

If you are a person with a disability who needs any accommodation in order to participate in this proceeding, you are entitled, at no cost to you, to the provision of certain assistance. Please contact the Sarasota County Jury Office, P.O. Box 3079, Sarasota, Florida 34230-3079, (941)861-7400, at least seven (7) days before your scheduled court appearance, or immediately upon receiving this notification if the time before the scheduled appearance is less than seven (7) days; if you are hearing or voice impaired, call 711.

WITNESS my hand and the seal of the court on December 6th, 2013.

KAREN E. RUSHING
 CLERK OF THE COURT
 (COURT SEAL) By: G. Kopinsky
 Deputy Clerk

Attorney for Plaintiff:
 Brian Streicher, Esq.
 Arlisa Certain, Esq.
 Elizabeth R. Wellborn, P.A.
 350 Jim Moran Blvd,
 Suite 100
 Deerfield Beach, FL 33442
 Telephone: (954) 354-3544
 Facsimile: (954) 354-3545
 Primary Email:
 bstreicher@erwlaw.com
 Secondary Email:
 servicecomplete@erwlaw.com
 8118-23262
 December 20, 27, 2013 13-05935S

FIRST INSERTION

NOTICE OF PUBLIC AUCTION/SALE FOR NON-JUDICIAL TIMESHARE FORECLOSURE

RE: GULF TIDES OF LONGBOAT KEY CONDOMINIUM ASSOCIATION, INC. Sarasota County, Florida

Non-Judicial Timeshare foreclosure process

NOTICE IS HEREBY GIVEN that, pursuant to of an action for non-judicial foreclosure of timeshare units on the Claim of Lien, which is dated June 24, 2013, and was recorded June 26, 2013, in the Official Records of Sarasota County, Florida, Instrument #2013089600 (2-pages), I will sell, to the highest and best bidder for cash, at the at GULF TIDES RESORT OFFICE, 3008 Gulf of Mexico Drive, Longboat Key, Sarasota County, Florida, 34228, on the Thursday, the 13th day of February, 2014, at 11:00 a.m., the following described real property located in Sarasota County, Florida, to-wit:

Unit Numbers and Week Numbers 102/15, 209/30, 209/28, 109/27, 105/31, 105/26, 210/29 and 210/50, in GULF TIDES OF LONGBOAT KEY, A Condominium, according to the Declaration of Condominium thereof, as recorded in Official Records Book 1446, Page 0429 through 0541, inclusive, as amended in Official Records Book 1451, Page 1275 and 1276, and Official records Book 1456, Pages 263 through 267, inclusive, and Official records Book 1596, Pages 1513 through 1541, inclusive, and as per plat thereof recorded in Condominium Book 17, Pages 7 and 7A through 7K, inclusive, amended in Condominium Book 17, Pages 26 and 26A through 26C, inclusive, and Condominium Book 20, Pages 38A through 38J, inclusive, together with any amendments or exhibits thereto, recorded in the Public Records of Sarasota County, Florida.

TO:	Unit(s)/Weeks(s)	Amount Due:
Unit owner(s) Bogdanski, Robert A. and Margaret Bogdanski PO Box 574 Florida, NY 10921	102/15	\$2,224.58
Brzostek, Arseniusz 3927 Orchard Hill Circle Palm Coast, FL 34684	209/30	\$3,609.17
Lightfoot, Charles 8615 Lenox Avenue Jacksonville, FL 32221	209/28	\$1,510.93
Riznyk, Wlodzimier and Teresa Riznyk 800 Belle Terre Parkway #200-139 Palm Coast, FL 32164	109/27	\$2,059.66
Ross, Maritza 8502 Woodhurst Drive Tampa, FL 33615	105/31	\$3,783.91
Stewart, Robert and Evesta Stewart 2441 Daytona -Xenia R Beavercreek, OH 45434	105/26	\$1,973.04
Watkins, Steven B. and Christina B. Watkins 410 Bryn Mawr Island Bradenton, FL 34207	210/29 210/50	\$5,273.32

The assessment lien created by the Claim of Lien was properly created and authorized pursuant to the timeshare instrument and applicable law, and the amounts secured by said lien are as set forth above. You may cure the default at any time prior to the public auction by paying the amount due, as set forth in this notice, to the undersigned Trustee at the address set forth below.

THIS NOTICE OF PUBLIC AUCTION/SALE is dated this 13 day of December, 2013.

CHARLES J. CINO, ESQUIRE, TRUSTEE
 CHARLES J. CINO, ESQUIRE
 TRUSTEE FOR GULF TIDES OF LONGBOAT KEY
 CONDOMINIUM ASSOCIATION, INC.
 555 West Granada Boulevard, Suite E-12
 Ormond Beach, FL 32174
 (386) 673-3420 / FAX (386) 673-0082
 email: cjbino@aol.com
 December 20, 27, 2013 13-05945S

FIRST INSERTION

NOTICE OF ACTION - CONSTRUCTIVE SERVICE IN THE CIRCUIT COURT OF THE TWELFTH JUDICIAL CIRCUIT OF FLORIDA IN AND FOR SARASOTA COUNTY, GENERAL JURISDICTION DIVISION

CASE NO. 2013 CA 007567 NC GREEN TREE SERVICING LLC, Plaintiff, vs.

VICTOR A. SPATOLA, JR. A/K/A VICTOR A. SPATOLA A/K/A VICTOR SPATOLA, JR. A/K/A VICTOR SPATOLA AND DARLENE S. SPATOLA A/K/A DARLENE SPATOLA, et. al. Defendant(s),

TO: VICTOR A. SPATOLA, JR. A/K/A VICTOR A. SPATOLA A/K/A VICTOR SPATOLA, JR. A/K/A VICTOR SPATOLA AND DARLENE S. SPATOLA A/K/A DARLENE SPATOLA

whose residence is unknown if he/she/they be living; and if he/she/they be dead, the unknown defendants who may be spouses, heirs, devisees, grantees, assignees, lienors, creditors, trustees, and all parties claiming an interest by, through, under or against the Defendants, who are not known to be dead or alive, and all parties having or claiming to have any right, title or interest in the property described in the mortgage being foreclosed herein.

YOU ARE HEREBY NOTIFIED that an action to foreclose a mortgage on the following property:

LOT 304, GROVE POINTE, UNIT 1, ACCORDING TO THE MAP OR PLAT THEREOF, AS RECORDED IN PLAT BOOK 34, PAGE 1, OF THE PUBLIC RECORDS OF SARASOTA COUNTY, FLORIDA.

has been filed against you and you

are required to serve a copy of your written defenses, if any, to it on counsel for Plaintiff, whose address is 6409 Congress Avenue, Suite 100, Boca Raton, Florida 33487 on or before 01-20-2014/(30 days from Date of First Publication of this Notice) and file the original with the clerk of this court either before service on Plaintiff's attorney or immediately thereafter; otherwise a default will be entered against you for the relief demanded in the complaint or petition filed herein.

THIS NOTICE SHALL BE PUBLISHED ONCE A WEEK FOR TWO (2) CONSECUTIVE WEEKS IN BUSINESS OBSERVER.

If you are a person with a disability who needs any accommodation in order to participate in this proceeding, you are entitled, at no cost to you, to the provision of certain assistance. Please contact the Sarasota County Jury Office, P.O. Box 3079, Sarasota, Florida 34230-3079, (941)861-7400, at least seven (7) days before your scheduled court appearance, or immediately upon receiving this notification if the time before the scheduled appearance is less than seven (7) days; if you are hearing or voice impaired, call 711.

WITNESS my hand and the seal of this Court at County, Florida, this 10th day of December, 2013.

KAREN E. RUSHING, CLERK
CLERK OF THE CIRCUIT COURT
(SEAL) BY: L. Szymanski
DEPUTY CLERK

ROBERTSON, ANSCHUTZ, AND SCHNEID, PL
ATTORNEY FOR PLAINTIFF
6409 CONGRESS AVENUE,
SUITE 100
BOCA RATON, FL 33487
December 20, 27, 2013 13-05899S

FIRST INSERTION

NOTICE OF ACTION - CONSTRUCTIVE SERVICE IN THE CIRCUIT COURT OF THE TWELFTH JUDICIAL CIRCUIT OF FLORIDA IN AND FOR SARASOTA COUNTY, GENERAL JURISDICTION DIVISION

CASE NO. 2013 CA 008111 NC JAMES B. NUTTER & COMPANY, Plaintiff, vs.

THE UNKNOWN HEIRS, BENEFICIARIES, DEVISEES, GRANTEES, ASSIGNEES, LIENORS, CREDITORS, TRUSTEES AND ALL OTHERS WHO MAY CLAIM AN INTEREST IN THE ESTATE OF JEWELL BAKER A/K/A WILLIE JEWELL BAKER, et. al. Defendant(s),

TO: THE UNKNOWN HEIRS, BENEFICIARIES, DEVISEES, GRANTEES, ASSIGNEES, LIENORS, CREDITORS, TRUSTEES AND ALL OTHERS WHO MAY CLAIM AN INTEREST IN THE ESTATE OF JEWELL BAKER A/K/A WILLIE JEWELL BAKER, et. al.

whose residence is unknown if he/she/they be living; and if he/she/they be dead, the unknown defendants who may be spouses, heirs, devisees, grantees, assignees, lienors, creditors, trustees, and all parties claiming an interest by, through, under or against the Defendants, who are not known to be dead or alive, and all parties having or claiming to have any right, title or interest in the property described in the mortgage being foreclosed herein.

YOU ARE HEREBY NOTIFIED that an action to foreclose a mortgage on the following property:

LOT 18, BLOCK A, HILL-CREST PARK, ACCORDING TO THE PLAT THEREOF, RECORDED IN PLAT BOOK 1, PAGE 15, OF THE PUBLIC

RECORDS OF SARASOTA COUNTY, FLORIDA has been filed against you and you are required to serve a copy of your written defenses, if any, to it on counsel for Plaintiff, whose address is 6409 Congress Avenue, Suite 100, Boca Raton, Florida 33487 on or before 01-20-14/(30 days from Date of First Publication of this Notice) and file the original with the clerk of this court either before service on Plaintiff's attorney or immediately thereafter; otherwise a default will be entered against you for the relief demanded in the complaint or petition filed herein.

THIS NOTICE SHALL BE PUBLISHED ONCE A WEEK FOR TWO (2) CONSECUTIVE WEEKS IN BUSINESS OBSERVER.

If you are a person with a disability who needs any accommodation in order to participate in this proceeding, you are entitled, at no cost to you, to the provision of certain assistance. Please contact the Sarasota County Jury Office, P.O. Box 3079, Sarasota, Florida 34230-3079, (941)861-7400, at least seven (7) days before your scheduled court appearance, or immediately upon receiving this notification if the time before the scheduled appearance is less than seven (7) days; if you are hearing or voice impaired, call 711.

WITNESS my hand and the seal of this Court at County, Florida, this 10th day of December, 2013.

KAREN E. RUSHING, CLERK
CLERK OF THE CIRCUIT COURT
(SEAL) BY: L. Szymanski
DEPUTY CLERK

ROBERTSON, ANSCHUTZ, AND SCHNEID, PL
ATTORNEY FOR PLAINTIFF
6409 CONGRESS AVENUE,
SUITE 100
BOCA RATON, FL 33487
December 20, 27, 2013 13-05900S

FIRST INSERTION

NOTICE OF ACTION IN THE CIRCUIT COURT OF THE TWELFTH JUDICIAL CIRCUIT IN AND FOR SARASOTA COUNTY, FLORIDA CIVIL ACTION

CASE NO.: 58-2011-CA-006755 NC ONEWEST BANK, FSB, Plaintiff, vs.

THE UNKNOWN HEIRS, DEVISEES, GRANTEES, ASSIGNEES, LIENORS, CREDITORS, TRUSTEES, OR OTHER CLAIMANTS CLAIMING BY, THROUGH, UNDER, OR AGAINST, DURO VASTAG, DECEASED, et al, Defendant(s).

To: THE UNKNOWN HEIRS, DEVISEES, GRANTEES, ASSIGNEES, LIENORS, CREDITORS, TRUSTEES, OR OTHER CLAIMANTS CLAIMING BY, THROUGH, UNDER, OR AGAINST, DURO VASTAG, DECEASED

Last Known Address: Unknown

Current Address: Unknown

ANY AND ALL UNKNOWN PARTIES CLAIMING BY, THROUGH, UNDER, AND AGAINST THE HEREIN NAMED INDIVIDUAL DEFENDANT(S) WHO ARE NOT KNOWN TO BE DEAD OR ALIVE, WHETHER SAID UNKNOWN PARTIES MAY CLAIM AN INTEREST AS SPOUSES, HEIRS, DEVISEES, GRANTEES, OR OTHER CLAIMANTS

Last Known Address: Unknown

Current Address: Unknown

YOU ARE NOTIFIED that an action to foreclose a mortgage on the following property in Sarasota County, Florida:

LOTS 2027 AND 2028 AND EAST 1/2 OF LOT 2029, SOUTH VENICE, UNIT NO. 6, AS PER PLAT THEREOF RECORDED IN PLAT

BOOK 6, PAGE 34, OF THE PUBLIC RECORDS OF SARASOTA COUNTY, FLORIDA A/K/A 1244 PORPOISE RD, VENICE, FL 34293-6110

has been filed against you and you are required to serve a copy of your written defenses within 30 days after the first publication, if any, on Albertelli Law, Plaintiff's attorney, whose address is P.O. Box 23028, Tampa, FL 33623, and file the original with this Court either before service on Plaintiff's attorney, or immediately thereafter; otherwise, a default will be entered against you for the relief demanded in the Complaint or petition.

This notice shall be published once a week for two consecutive weeks in the Business Observer.

If you are a person with a disability who needs any accommodation in order to participate in this proceeding, you are entitled, at no cost to you, to the provision of certain assistance. Please contact the Sarasota County Jury Office, P.O. Box 3079, Sarasota, Florida 34230-3079, (941)861-7400, at least seven (7) days before your scheduled court appearance, or immediately upon receiving this notification if the time before the scheduled appearance is less than seven (7) days; if you are hearing or voice impaired, call 711.

WITNESS my hand and the seal of this court on this 6 day of December, 2013.

KAREN E. RUSHING, CLERK
Clerk of the Circuit Court
(SEAL) By: G. Kopinsky
Deputy Clerk

Albertelli Law
P.O. Box 23028
Tampa, FL 33623
JG -11-87862
December 20, 27, 2013 13-05932S

SUBSEQUENT INSERTIONS

SECOND INSERTION

NOTICE TO CREDITORS (summary administration) IN THE CIRCUIT COURT FOR SARASOTA COUNTY, FLORIDA PROBATE DIVISION

File No: 2013 CP 004556 NC IN RE ESTATE OF: GERALDINE MARGARET DUNN, Deceased.

TO ALL PERSONS HAVING CLAIMS OR DEMANDS AGAINST THE ABOVE ESTATE:

You are hereby notified that an Order of Summary Administration has been entered in the estate of GERALDINE MARGARET DUNN deceased, File Number 2013 CP 004556 NC; by the Circuit Court for Sarasota County, Florida, Probate Division, the address of which is 4000 S. Tamiami Trail, Venice, FL 34293; that the decedent's date of death was February 9, 2013; that the total value of the estate is \$11,726.11 and that the names of those to whom it has been assigned by such order are:

Name Address
Creditors:
Mark W. Mazzeo, Esquire
4140 Woodmere Park Blvd.
Venice, FL 34293
Beneficiaries:
THOMAS J. DUNN
416 Donnell Road
Lower Burrell, PA 15068
LINDA JO DUNN
1926 Constitution Blvd.
Arnold, PA 15068
HARRY D. DUNN
151 Tabbs Cove Lane
White Stone, VA 22578
LAURIE A. BENNINGTON

12205 Dewey Road
Silver Spring, MD 20909
ALL INTERESTED PERSONS ARE NOTIFIED THAT:

All creditors of the estate of the decedent and persons having claims or demands against the estate of the decedent other than those for whom provision for full payment was made in the Order of Summary Administration must file their claims with this court WITHIN THE TIME PERIODS SET FORTH IN SECTION 733.702 OF THE FLORIDA PROBATE CODE. ALL CLAIMS AND DEMANDS NOT SO FILED WILL BE FOREVER BARRED. NOTWITHSTANDING ANY OTHER APPLICABLE TIME PERIOD, ANY CLAIM FILED TWO (2) YEARS OR MORE AFTER THE DECEDENT'S DATE OF DEATH IS BARRED.

The date of first publication of this Notice is December 13, 2013.

Person Giving Notice:
THOMAS J. DUNN
416 Donnell Road
Lower Burrell, PA 15068

Attorney for Person Giving Notice:
Mark W. Mazzeo, Esquire
Attorney for Petitioner
Email: mmazzeo@veniceelderlaw.com
Secondary Email:
e-service@veniceelderlaw.com
Florida Bar No. 119350
Mazzeo & Staas, P.L.
4140 Woodmere Park Blvd.
Suite 4
Venice, FL 34293
Telephone: 941-408-8555
December 13, 20, 2013 13-05875S

SECOND INSERTION

NOTICE OF SALE IN THE CIRCUIT COURT OF THE TWELFTH JUDICIAL CIRCUIT OF THE STATE OF FLORIDA, IN AND FOR SARASOTA COUNTY CIVIL DIVISION

CASE NO. 58-2012-CA-000089-0000-NC EVERBANK, Plaintiff, vs.

DEREK R. HERSHBERGER; UNKNOWN SPOUSE OF DEREK R. HERSHBERGER; SAMANTHA J. BURKE; UNKNOWN SPOUSE OF SAMANTHA J. BURKE; IF LIVING, INCLUDING ANY UNKNOWN SPOUSE OF SAID DEFENDANT(S), IF REMARRIED, AND IF DECEASED, THE RESPECTIVE UNKNOWN

HEIRS, DEVISEES, GRANTEES, ASSIGNEES, CREDITORS, LIENORS, AND TRUSTEES, AND ALL OTHER PERSONS CLAIMING BY, THROUGH, UNDER OR AGAINST THE NAMED DEFENDANT(S); UNKNOWN TENANT #1; 3165 LOBELIA ROAD; Defendant(s)

Notice is hereby given that, pursuant to a Final Summary Judgment of Foreclosure entered on 11/07/2013 in the above styled cause, in the Circuit Court of Sarasota County, Florida, the office of Karen E. Rushing clerk of the circuit court will sell the property situate in Sarasota County, Florida, described as:
LOTS 17686 AND 17687S,
SOUTH VENICE, UNIT NO. 66,

ACCORDING TO THE PLAT THEREOF, AS RECORDED IN PLAT BOOK 7, PAGE 45, OF THE PUBLIC RECORDS OF SARASOTA COUNTY, FLORIDA.

at public sale, to the highest and best bidder, for cash, www.sarasotaareal-foreclose.com at 9:00 o'clock, A.M., on January 6, 2014

Any person claiming an interest in the surplus from the sale, if any, other than the property owner as of the date of the lis pendens, must file a claim within 60 days after the sale.

If you are a person with a disability who needs any accommodation in order to participate in this proceeding, you are entitled, at no cost to you, to the provision of certain assistance. Please contact the Sarasota County Jury Of-

ice, P.O. Box 3079, Sarasota, Florida 34230-3079, (941)861-7400, at least seven (7) days before your scheduled court appearance, or immediately upon receiving this notification if the time before the scheduled appearance is less than seven (7) days; if you are hearing or voice impaired, call 711.

ATTORNEY FOR PLAINTIFF
By Josh D. Donnelly
Florida Bar #64788

Date: 12/10/2013
THIS INSTRUMENT PREPARED BY:
Law Offices Of Daniel C. Consuegra
9204 King Palm Drive
Tampa, FL 33619-1328
Phone: 813-915-8660
Attorneys for Plaintiff
112689
December 13, 20, 2013 13-05860S

SECOND INSERTION

NOTICE OF ACTION IN THE CIRCUIT COURT OF THE TWELFTH JUDICIAL CIRCUIT, IN AND FOR SARASOTA COUNTY, FLORIDA

CASE NO. 2010 CA 010213 NC BANK OF AMERICA, N.A., Plaintiff, vs.

GLEN J. WHITNEY, ET AL. Defendants
To the following Defendant(s): UNKNOWN SPOUSE OF EILEEN E. WHITNEY A/K/A EE WHITNEY (CURRENT RESIDENCE UNKNOWN)
Last known address: 4312 ROCKEFELLER AVENUE, SARASOTA, FL 34231
UNKNOWN SPOUSE OF GLEN J. WHITNEY (CURRENT RESIDENCE UNKNOWN)
Last known address: 4312 ROCKEFELLER AVENUE, SARASOTA, FL 34231

YOU ARE HEREBY NOTIFIED that an action for Foreclosure of Mortgage on the following described property:

LOTS 6 AND 8, BLOCK 4, GOLF ESTATES, AS PER PLAT THEREOF RECORDED IN PLAT BOOK 2, PAGE 131, OF THE PUBLIC RECORDS OF SARASOTA COUNTY, FLORIDA. LESS THE WESTERN-MOST TWO FEET (2') OF LOTS 6 AND 8, BLOCK 4 OF GOLF ESTATES (WHICH DIRECTLY BORDER LOTS 5 AND 7, BLOCK 4 OF GOLF ESTATES), A SUBDIVISION IN SECTION 4, TOWNSHIP 37 SOUTH, RANGE 18 EAST AS RECORDED IN PLAT BOOK NO.2, PAGE 131, OF THE PUBLIC RECORDS OF SARASOTA COUNTY, FLORIDA. TOGETHER WITH A PERPETUAL NON-EXCLUSIVE EASEMENT FOR INGRESS, EGRESS, ROAD PURPOSES, DRAINAGE AND UTILITY USE, OVER, UNDER, UPON AND ACROSS THE SOUTH 10 FEET OF LOT 3, BLOCK 4 AND THE NORTH 10 FEET

OF LOT 5, BLOCK 4, GOLF ESTATES, AS RECORDED IN OFFICIAL RECORDS BOOK 1252, PAGE 1463 AND OFFICIAL RECORDS BOOK 1252, PAGE 1465, RESPECTIVELY, OF SAID RECORDS. A/K/A 4312 ROCKEFELLER AVE, SARASOTA, FL 34231

has been filed against you and you are required to serve a copy of your written defenses, if any, to Morgan E. Long, Esq. at VAN NESS LAW FIRM, PLC, Attorney for the Plaintiff, whose address is 1239 E. NEWPORT CENTER DRIVE, SUITE #110, DEERFIELD BEACH, FL 33442 on or before January 13, 2014 a date which is within thirty (30) days after the first publication of this Notice in the BUSINESS OBSERVER and file the original with the Clerk of this Court either before service on Plaintiff's attorney or immediately thereafter; otherwise a default will be entered against you for the relief demanded in the complaint. This notice is provided to Administrative Order No. 2065

If you are a person with a disability who needs any accommodation in order to participate in this proceeding, you are entitled, at no cost to you, to the provision of certain assistance. Please contact the Sarasota County Jury Office, P.O. Box 3079, Sarasota, Florida 34230-3079, (941)861-7400, at least seven (7) days before your scheduled court appearance, or immediately upon receiving this notification if the time before the scheduled appearance is less than seven (7) days; if you are hearing or voice impaired, call 711.

WITNESS my hand and the seal of this Court this 4 day of December, 2013
KAREN E. RUSHING
CLERK OF COURT
(SEAL) By K. Goodspeed
As Deputy Clerk

Morgan E. Long, Esq.
VAN NESS LAW FIRM, PLC,
Attorney for the Plaintiff
1239 E. NEWPORT CENTER DRIVE,
SUITE #110,
DEERFIELD BEACH, FL 33442
FN11833-10NS/asc
December 13, 20, 2013 13-05803S

SECOND INSERTION

NOTICE OF ACTION IN THE CIRCUIT COURT OF THE TWELFTH JUDICIAL CIRCUIT IN AND FOR SARASOTA COUNTY, FLORIDA

CASE NO.: 58-2013-CA-006828 NC WELLS FARGO BANK, N.A. Plaintiff, v.

MARIA SCHMIDT; ET AL. Defendants.
TO: MARIA SCHMIDT; and all unknown parties claiming by, through, under or against the above named Defendant, who is not known to be dead or alive, whether said unknown parties claim as heirs, devisees, grantees, assignees, lienors, creditors, trustees, spouses, or other claimants
Current Residence Unknown, but whose last known address was: 1515 STEWART DR. UNIT 118, SARASOTA, FL 34232-3217
727 HUDSON AVE APT 203 SARASOTA FL 34236-4700

YOU ARE NOTIFIED that an action to foreclose a mortgage on the following property in Sarasota County, Florida, to-wit:

UNIT 118, SECTION ONE, FOREST PINES CONDOMINIUM, A CONDOMINIUM ACCORDING TO THE DECLARATION OF CONDOMINIUM AS RECORDED IN OFFICIAL RECORDS BOOK 926, PAGES 377 THROUGH 421, AND AMENDMENTS THERETO, TOGETHER WITH AMENDMENT MERGING SECTIONS 1 THROUGH 10 INTO A SINGLE CONDOMINIUM NOW KNOWN AS FOREST PINES CONDOMINIUM AS RECORDED IN OFFICIAL RECORDS BOOK 1698, PAGE 813, AND AS PER PLAT THEREOF, RECORDED IN CONDOMINIUM BOOK 5, PAGE 13, AND AMEND-

MENTS THERETO, PUBLIC RECORDS OF SARASOTA COUNTY, FLORIDA.

has been filed against you and you are required to serve a copy of your written defenses, if any, to it on DOUGLAS C. ZAHM, P.A., Plaintiff's attorney, whose address is 12425 28th Street North, Suite 200, St. Petersburg, FL 33716, on or before 1-13-2014 or within thirty (30) days after the first publication of this Notice of Action, and file the original with the Clerk of this Court at 2000 Main Street, Sarasota FL 34237, either before service on Plaintiff's attorney or immediately thereafter; otherwise, a default will be entered against you for the relief demanded in the complaint petition.

If you are a person with a disability who needs any accommodation in order to participate in this proceeding, you are entitled, at no

cost to you, to the provision of certain assistance. Please contact the Sarasota County Jury Office, P.O. Box 3079, Sarasota, Florida 34230-3079, (941)861-7400, at least seven (7) days before your scheduled court appearance, or immediately upon receiving this notification if the time before the scheduled appearance is less than seven (7) days; if you are hearing or voice impaired, call 711.

WITNESS my hand and seal of the Court on this 27 day of November, 2013.

Karen E. Rushing
Clerk of the Circuit Court
(SEAL) By: G. Kopinsky
Deputy Clerk

DOUGLAS C. ZAHM, P.A.,
Plaintiff's attorney
12425 28th Street North,
Suite 200
St. Petersburg, FL 33716
888131653
December 13, 20, 2013 13-05805S

SAVE TIME
E-mail your Legal Notice
legal@businessobserverfl.com
Sarasota / Manatee counties
Hillsborough County
Pasco County
Pinellas County
Lee County
Collier County
Charlotte County
Wednesday Noon Deadline
Friday Publication
Business Observer

SECOND INSERTION

NOTICE OF ACTION IN THE CIRCUIT COURT OF THE 12TH JUDICIAL CIRCUIT, IN AND FOR SARASOTA COUNTY, FLORIDA

CIVIL DIVISION CASE NO.: 58-2013-CA-006872 NC FEDERAL NATIONAL MORTGAGE ASSOCIATION, Plaintiff, vs. JUSTIN BLUM A/K/A JUSTIN SCOTT BLUM, et al., Defendants.

JUSTIN BLUM A/K/A JUSTIN SCOTT BLUM Last Known Address: 4394 CUTHBERT AVENUE, NORTH PORT, FL 34287

Also Attempted At: 1178 SLADE AVE, COLUMBUS, OH 43235 4051 4053 LANCASTER DR, SARASOTA, FL 34241 Current Residence Unknown YOU ARE NOTIFIED that an action for Foreclosure of Mortgage on the following described property:

LOT 5, BLOCK 289, 1ST ADDITION TO PORT CHARLOTTE SUBDIVISION, ACCORDING TO THE PLAT THEREOF AS RECORDED IN PLAT BOOK 11, PAGE(S) 29, 29A THROUGH 29J, INCLUSIVE, OF THE PUBLIC RECORDS OF SARASOTA COUNTY, FLORIDA

has been filed against you and you are required to serve a copy of your written defenses, if any, to it, on Choice Legal Group, P.A., Attorney for Plaintiff, whose address is 1800 NW 49TH STREET, SUITE 120, FT. LAUDERDALE FL 33309 on or before January 13, 2014, a date which is within thirty (30) days after the first publication of this Notice in the BUSINESS OBSERVER and file the original with the Clerk of this Court either before service on Plaintiff's attorney or immediately thereafter; otherwise a default will be entered against you for the relief demanded in the complaint.

If you are a person with a disability who needs any accommodation in order to participate in this proceeding, you are entitled, at no cost to you, to the provision of certain assistance.

WITNESS my hand and the seal of this Court this 2 day of December, 2013.

KAREN E. RUSHING As Clerk of the Court (SEAL) By G Kopinsky As Deputy Clerk

Choice Legal Group, P.A., Attorney for Plaintiff 1800 NW 49TH STREET, SUITE 120 FT. LAUDERDALE, FL 33309 13-04233 December 13, 20, 2013 13-05794S

SECOND INSERTION

RE-NOTICE OF SALE PURSUANT TO CHAPTER 45 IN THE CIRCUIT COURT OF THE 12TH JUDICIAL CIRCUIT, IN AND FOR SARASOTA COUNTY, FLORIDA.

CASE NO.: 2010 CA 004169 NC GOLDMAN SACHS MORTGAGE COMPANY, Plaintiff, vs. LARRY W. SANDERS, Defendant.

NOTICE OF SALE IS HEREBY GIVEN pursuant to a Summary Final Judgment of Foreclosure dated March 26, 2013, and to an order on plaintiff's motion to reset judicial sale, and issue re-notice of sale, docketed November 26, 2013, and entered in Case No. 2010 CA 004169 NC of the Circuit Court of the 12th Judicial Circuit in and for Sarasota County, Florida, wherein GOLDMAN SACHS MORTGAGE COMPANY, is Plaintiff and LARRY W. SANDERS is Defendant, I will sell to the highest and best bidder for cash via online at www.sarasota.realforeclose.com at 9:00AM on the 31st day of December, 2013, the following described property as set forth in said Summary Final Judgment, to wit:

LOT 346, RIDGEWOOD ESTATES, 3RD ADDITION, ACCORDING TO THE PLAT THEREOF, RECORDED IN PLAT BOOK 13, PAGE 21, OF THE PUBLIC RECORDS OF SARASOTA COUNTY, FLORIDA.

Located: 3524 Papai Drive, Sarasota, FL 34232 and all fixtures and personal property located therein or thereon, which are included as security in Plaintiff's mortgage.

Any person claiming an interest in the surplus funds from the sale, if any, other than the property owner as of the date of the lis pendens must file a claim within 60 days after the sale.

If you are a person with a disability who needs any accommodation in order to participate in this proceeding, you are entitled, at no cost to you, to the provision of certain assistance. Please contact the Sarasota County Jury Office, P.O. Box 3079, Sarasota, Florida 34230-3079, (941)861-7400, at least seven (7) days before your scheduled court appearance, or immediately upon receiving this notification if the time before the scheduled appearance is less than seven (7) days; if you are hearing or voice impaired, call 711.

Dated this 4th day of December, 2013.

By: Marc Ruderman Fl. Bar # 899585

Clarfield, Okon, Salomone & Pincus, P.L. 500 S. Australian Avenue, Suite 730 West Palm Beach, FL 33401 (561) 713-1400 pleadings@cosplaw.com December 13, 20, 2013 13-05795S

SECOND INSERTION

AMENDED NOTICE OF ACTION IN THE CIRCUIT COURT OF THE 12TH JUDICIAL CIRCUIT IN AND FOR SARASOTA COUNTY, FLORIDA

GENERAL JURISDICTION DIVISION Case No: 2009-CA-11046-NC AS DIOMEDES LLC, Plaintiff, vs. DAVID BEBIKH, et al., Defendants.

To the following Defendant(s): PINNACLE FINANCIAL CORPORATION d/b/a Tri-Star Lending Group (2611 TECHNOLOGY DRIVE, ORLANDO, FL 32804)

YOU ARE NOTIFIED that an action has been filed against you for Foreclosure Note and Mortgage on the following described property: LOT 13, BLOCK 565, 18TH ADDITION TO PORT CHARLOTTE, ACCORDING TO THE PLAT THEREOF AS RECORDED ON PLAT BOOK 14, PAGE 6, OF THE PUBLIC RECORDS OF COLLIER COUNTY.

Property Address: 4414 Kendall Avenue, North Port, FL 34286 and you are required to serve a copy of your written defenses, if any, to it, on AIRAN PACE LAW, P.A., Rashmi Airan-Pace, Esq., Attorney for Plaintiff, whose address is 6705 Red Road, Suite 310, Coral Gables, Florida 33143 Phone: (305) 666-9311 on or before January 13th, 2014, a date which is within thirty (30) days after the first publication of this Notice in BUSINESS OBSERVER and file the original with the Clerk at the Sarasota County Courthouse, either before service on Plaintiff's attorney or immediately thereafter; otherwise a default will be entered against you for the relief demanded in the complaint.

If you are a person with a disability who needs any accommodation in order to participate in this proceeding, you are entitled, at no cost to you, to the provision of certain assistance. Please contact the Sarasota County Jury Office, P.O. Box 3079, Sarasota, Florida 34230-3079, (941)861-7400, at least seven (7) days before your scheduled court appearance, or immediately upon receiving this notification if the time before the scheduled appearance is less than seven (7) days; if you are hearing or voice impaired, call 711.

WITNESS my hand and the seal of this Court this 6th day of December, 2013.

As Clerk of the Court (SEAL) By L. Szymanski As Deputy Clerk

AIRAN PACE LAW, P.A. Rashmi Airan-Pace, Esq. Attorney for Plaintiff 6705 Red Road, Suite 310 Coral Gables, Florida 34443 Phone: (305) 666-9311 December 13, 20, 2013 13-05823S

SECOND INSERTION

AMENDED NOTICE OF ACTION IN THE CIRCUIT COURT OF THE TWELFTH JUDICIAL CIRCUIT IN AND FOR SARASOTA COUNTY, FLORIDA

CASE NO.: 2012 CA 008950 NC PHH MORTGAGE CORPORATION, Plaintiff, vs. DANIEL MELZER; GLENDA F. MELZER; et al., Defendant(s).

TO: Daniel Melzer Last Known Residence: Unknown Unknown Spouse of Daniel Melzer Last Known Residence: Unknown YOU ARE HEREBY NOTIFIED that an action to foreclose a mortgage on the following property in SARASOTA County, Florida:

UNIT NO. 204, BUILDING NO. 4, THE GARDENS II AT WATERSIDE VILLAGE, A CONDOMINIUM ACCORDING TO THE DECLARATION OF CONDOMINIUM RECORDED IN OFFICIAL RECORDS BOOK 2884, PAGE 2106, AND AMENDMENTS THERETO, AND AS PER PLAT THEREOF, RECORDED IN CONDOMINIUM BOOK 31, PAGE 29, AND AMENDMENTS THERETO, PUBLIC RECORDS OF SARASOTA COUNTY, FLORIDA.

has been filed against you and you are required to serve a copy of your written defenses, if any, to it, on Choice Legal Group, P.A., Attorney for Plaintiff, whose address is 1800 NW 49TH STREET, SUITE 120, FT. LAUDERDALE FL 33309 on or before January 13, 2014, a date which is within thirty (30) days after the first publication of this Notice in the BUSINESS OBSERVER and file the original with the Clerk of this Court either before service on Plaintiff's attorney or immediately thereafter; otherwise a default will be entered against you for the relief demanded in the complaint or petition.

If you are a person with a disability who needs any accommodation in order to participate in this proceeding, you are entitled, at no cost to you, to the provision of certain assistance. Please contact the Sarasota County Jury Office, P.O. Box 3079, Sarasota, Florida 34230-3079, (941)861-7400, at least seven (7) days before your scheduled court appearance, or immediately upon receiving this notification if the time before the scheduled appearance is less than seven (7) days; if you are hearing or voice impaired, call 711.

Dated on December 3rd, 2013.

KAREN E. RUSHING As Clerk of the Court (SEAL) By: G. Kopinsky As Deputy Clerk

ALDRIDGE | CONNORS, LLP Plaintiff's Attorney 1615 South Congress Avenue, Suite 200 Delray Beach, FL 33445 Phone Number: (561) 392-6391 1271-182 December 13, 20, 2013 13-05790S

SECOND INSERTION

NOTICE OF ACTION IN THE CIRCUIT COURT OF THE 12TH JUDICIAL CIRCUIT, IN AND FOR SARASOTA COUNTY, FLORIDA

CIVIL DIVISION CASE NO.: 58-2013-CA-007939 NC FEDERAL NATIONAL MORTGAGE ASSOCIATION, Plaintiff, vs. DESMOND LOUEY, et al., Defendants.

TO: BRANDON NEAL Last Known Address: 3357 N. CHAMBERLAIN BLVD., NORTH PORT, FL 34286

Also Attempted At: 11299 7TH AVE., PUNTA GORDA, FL 33955 Current Residence Unknown YOU ARE NOTIFIED that an action for Foreclosure of Mortgage on the following described property:

LOTS 4 AND 5, BLOCK 896, TWENTIETH ADDITION TO PORT CHARLOTTE SUBDIVISION, ACCORDING TO THE PLAT THEREOF AS RECORDED IN PLAT BOOK 14, PAGE(S) 8, 8A THROUGH 8K, PUBLIC RECORDS OF SARASOTA COUNTY, FLORIDA.

has been filed against you and you are required to serve a copy of your written defenses, if any, to it, on Choice Legal Group, P.A., Attorney for Plaintiff, whose address is 1800 NW 49TH STREET, SUITE 120, FT. LAUDERDALE FL 33309 on or before January 13, 2014, a date which is within thirty (30) days after the first publication of this Notice in the BUSINESS OBSERVER and file the original with the Clerk of this Court either before service on Plaintiff's attorney or immediately thereafter; otherwise a default will be entered against you for the relief demanded in the complaint.

If you are a person with a disability who needs any accommodation in order to participate in this proceeding, you are entitled, at no cost to you, to the provision of certain assistance. Please contact the Sarasota County Jury Office, P.O. Box 3079, Sarasota, Florida 34230-3079, (941)861-7400, at least seven (7) days before your scheduled court appearance, or immediately upon receiving this notification if the time before the scheduled appearance is less than seven (7) days; if you are hearing or voice impaired, call 711. WITNESS my hand and the seal of this Court this 4 day of December, 2013. KAREN E. RUSHING As Clerk of the Court (SEAL) By K Goodspeed As Deputy Clerk Choice Legal Group, P.A., Attorney for Plaintiff 1800 NW 49TH STREET, SUITE 120 FT. LAUDERDALE, FL 33309 13-02457 December 13, 20, 2013 13-05793S

SECOND INSERTION

NOTICE OF ACTION IN THE CIRCUIT COURT OF THE 12TH JUDICIAL CIRCUIT, IN AND FOR SARASOTA COUNTY, FLORIDA

CIVIL DIVISION CASE NO.: 58-2013-CA-007865 NC FEDERAL NATIONAL MORTGAGE ASSOCIATION, Plaintiff, vs. RONALD REITZ A/K/A RONALD G. REITZ, et al., Defendants.

TO: SUSANA REITZ Last Known Address: 5624 EAST-WIND DR, SARASOTA, FL 34233

Also Attempted At: 3999 BEDROCK CT, ANTIPOCH, CA 94509 Current Residence Unknown YOU ARE NOTIFIED that an action for Foreclosure of Mortgage on the following described property:

LOT 552, THREE OAKS, UNIT 2, AS PER PLAT THEREOF RECORDED IN PLAT BOOK 41, PAGE 40, OF THE PUBLIC RECORDS OF SARASOTA COUNTY, FLORIDA.

has been filed against you and you are required to serve a copy of your written defenses, if any, to it, on Choice Legal Group, P.A., Attorney for Plaintiff, whose address is 1800 NW 49TH STREET, SUITE 120, FT. LAUDERDALE FL 33309 on or before 1-13-2014, a date which is within thirty (30) days after the first publication of this Notice in the BUSINESS OBSERVER and file the original with the Clerk of this Court either before service on Plaintiff's attorney or immediately thereafter; otherwise a default will be entered against you for the relief demanded in the complaint.

If you are a person with a disability who needs any accommodation in order to participate in this proceeding, you are entitled, at no cost to you, to the provision of certain assistance. Please contact the Sarasota County Jury Office, P.O. Box 3079, Sarasota, Florida 34230-3079, (941)861-7400, at least seven (7) days before your scheduled court appearance, or immediately upon receiving this notification if the time before the scheduled appearance is less than seven (7) days; if you are hearing or voice impaired, call 711.

WITNESS my hand and the seal of this Court this 4 day of December, 2013.

KAREN E. RUSHING As Clerk of the Court (SEAL) By G. Kopinsky As Deputy Clerk

Choice Legal Group, P.A., Attorney for Plaintiff 1800 NW 49TH STREET, SUITE 120 FT. LAUDERDALE, FL 33309 13-05725 December 13, 20, 2013 13-05792S

SECOND INSERTION

NOTICE OF ACTION - CONSTRUCTIVE SERVICE IN THE CIRCUIT COURT OF THE TWELFTH JUDICIAL CIRCUIT OF FLORIDA IN AND FOR SARASOTA COUNTY,

GENERAL JURISDICTION DIVISION CASE NO. 2013 CA 007486 NC HOUSEHOLD FINANCE CORP III, Plaintiff, vs. RODNEY D. JONES AKA RODNEY JONES AND HELEN V. JONES A/K/A HELEN JONES, et. al. Defendant(s),

TO: RODNEY D. JONES AKA RODNEY JONES AND HELEN V. JONES A/K/A HELEN JONES whose residence is unknown if he/she/they be living; and if he/she/they be dead, the unknown defendants who may be spouses, heirs, devisees, grantees, assignees, lienors, creditors, trustees, and all parties claiming an interest by, through, under or against the Defendants, who are not known to be dead or alive, and all parties having or claiming to have any right, title or interest in the property described in the mortgage being foreclosed herein.

YOU ARE HEREBY NOTIFIED that an action to foreclose a mortgage on the following property: LOT 12, BLOCK 11, EAST GATE UNIT NO. 1, ACCORDING TO THE PLAT THEREOF, RECORDED IN PLAT BOOK 9, PAGE 43, OF THE PUBLIC RECORDS OF SARASOTA COUNTY, FLORIDA.

has been filed against you and you are required to serve a copy of your written defenses, if any, to it on counsel for

Plaintiff, whose address is 6409 Congress Avenue, Suite 100, Boca Raton, Florida 33487 on or before/(30 days from Date of First Publication of this Notice) and file the original with the clerk of this court either before service on Plaintiff's attorney or immediately thereafter; otherwise a default will be entered against you for the relief demanded in the complaint or petition filed herein.

THIS NOTICE SHALL BE PUBLISHED ONCE A WEEK FOR TWO (2) CONSECUTIVE WEEKS IN BUSINESS OBSERVER.

If you are a person with a disability who needs any accommodation in order to participate in this proceeding, you are entitled, at no cost to you, to the provision of certain assistance. Please contact the Sarasota County Jury Office, P.O. Box 3079, Sarasota, Florida 34230-3079, (941)861-7400, at least seven (7) days before your scheduled court appearance, or immediately upon receiving this notification if the time before the scheduled appearance is less than seven (7) days; if you are hearing or voice impaired, call 711.

WITNESS my hand and the seal of this Court at County, Florida, this day of December, 2013.

KAREN E. RUSHING, CLERK CLERK OF THE CIRCUIT COURT (SEAL) BY: K. Goodspeed DEPUTY CLERK

ROBERTSON, ANSCHUTZ, AND SCHNEID, PL ATTORNEY FOR PLAINTIFF 6409 CONGRESS AVENUE, SUITE 100 BOCA RATON, FL 33487 December 13, 20, 2013 13-05801S

SECOND INSERTION

NOTICE OF FORECLOSURE SALE IN THE CIRCUIT COURT IN AND FOR SARASOTA COUNTY, FLORIDA

2007-CA-015894-NC-C FINANCIAL FREEDOM SENIOR FUNDING CORPORATION Plaintiff, vs.

LINDA FERNE COLLINS, AS RESIDUARY BENEFICIARY OF THE TRUST U/A MARGARET ELIZABETH BENEDICT DATED OCTOBER 28, 1988; LINDA FERNE COLLINS, AS TRUSTEE OF TRUST U/A MARGARET ELIZABETH BENEDICT DATED OCTOBER 28, 1988; UNKNOWN SPOUSE OF MARGARET BENEDICT; UNKNOWN TENANT I; UNKNOWN TENANT II; UNITED STATES OF AMERICA; STATE OF FLORIDA DEPARTMENT OF REVENUE; UNITED STATES OF AMERICA ON BEHALF OF THE SECRETARY OF HOUSING AND URBAN DEVELOPMENT, and any unknown heirs, devisees, grantees, creditors, and other unknown persons or unknown spouses claiming by, through and under any of the above-named Defendants, Defendants.

NOTICE is hereby given that the Clerk of the Circuit Court of Sarasota County, Florida, will on the 14th day of January 2014, at 9:00 AM at www.sarasota.realforeclose.com in accordance with Chapter 45 Florida Statutes, offer for sale and sell at public outcry to the highest and best bidder for cash, the following-described property situate in Sarasota County, Florida: Lot 81, THE MEADOWS, UNIT 2, as per Plat thereof recorded

in Plat Book 24, Pages 23, 23A through 23G, of the Public Records of Sarasota County, Florida, pursuant to the Final Judgment entered in a case pending in said Court, the style of which is indicated above.

Any person or entity claiming an interest in the surplus, if any, resulting from the foreclosure sale, other than the property owner as of the date of the Lis Pendens, must file a claim on same with the Clerk of Court within 60 days after the foreclosure sale. If you are a person with a disability who needs any accommodation in order to participate in this proceeding, you are entitled, at no cost to you, to the provision of certain assistance. Please contact the Sarasota County Jury Office, P.O. Box 3079, Sarasota, Florida 34230-3079, (941)861-7400, at least seven (7) days before your scheduled court appearance, or immediately upon receiving this notification if the time before the scheduled appearance is less than seven (7) days; if you are hearing or voice impaired, call 711

DATED this 4th day of December, 2013.

Ronnie A. Syme, Esquire Bar # 77099 for Matthew R. Stubbs, Esquire Florida Bar Number# 102871 Morgan B. Lea, Esquire BUTLER & HOSCH, P.A. 3185 South Conway Road, Suite E Orlando, Florida 32812 Telephone: (407) 381-5200 Fax: (407) 381-5577 Florida Bar No: 96405 ml96405@butlerandhosch.com FLpleadings@butlerandhosch.com B&H # 254771 December 13, 20, 2013 13-05791S

SECOND INSERTION

NOTICE OF ACTION IN THE CIRCUIT COURT OF THE TWELFTH JUDICIAL CIRCUIT IN AND FOR SARASOTA COUNTY, FLORIDA

CIVIL ACTION CASE NO.: 58-2013-CA-007310 NC WELLS FARGO BANK, N.A., SUCCESSOR BY MERGER TO WACHOVIA MORTGAGE, FSB, FORMERLY KNOWN AS WORLD SAVINGS BANK, FSB, FORMERLY KNOWN AS WORLD SAVINGS AND LOAN ASSOCIATION, Plaintiff, vs. ALAN GLASS, ET AL, Defendant(s).

TO: ALAN GLASS STUART GLASS THE UNKNOWN SPOUSE OF ALAN GLASS THE UNKNOWN SPOUSE OF STUART GLASS Last Known Address: 1246 Sea Plume Way, Sarasota, FL 34242

Current Address: Unknown ANY AND ALL UNKNOWN PARTIES CLAIMING BY, THROUGH, UNDER, AND AGAINST THE HEREIN NAMED INDIVIDUAL DEFENDANT(S) WHO ARE NOT KNOWN TO BE DEAD OR ALIVE, WHETHER SAID UNKNOWN PARTIES MAY CLAIM AN INTEREST AS SPOUSES, HEIRS, DEVISEES, GRANTEEES, OR OTHER CLAIMANTS Last Known Address: Unknown Current Address: Unknown YOU ARE NOTIFIED that an action to foreclose a mortgage on the following property in Sarasota County, Florida:

LOT 16, THE MANGROVES SUBDIVISION, AS PER PLAT THEREOF RECORDED IN PLAT BOOK 23, PAGE 5

AND 5A, OF THE PUBLIC RECORDS OF SARASOTA COUNTY, FLORIDA .. A/KIA 1246 SEA PLUME WAY, SARASOTA, FL 34242

has been filed against you and you are required to serve a copy of your written defenses within 30 days after the first publication, if any, on Albertelli Law, Plaintiff's attorney, whose address is P.O. Box 23028, Tampa, FL 33623, and file the original with this Court either before 1-13-2014 service on Plaintiff's attorney, or immediately thereafter; otherwise, a default will be entered against you for the relief demanded in the Complaint or petition.

This notice shall be published once a week for two consecutive weeks in the Business Observer.

If you are a person with a disability who needs any accommodation in order to participate in this proceeding, you are entitled, at no cost to you, to the provision of certain assistance. Please contact the Sarasota County Jury Office, P.O. Box 3079, Sarasota, Florida 34230-3079, (941)861-7400, at least seven (7) days before your scheduled court appearance, or immediately upon receiving this notification if the time before the scheduled appearance is less than seven (7) days; if you are hearing or voice impaired, call 711.

WITNESS my hand and the seal of this court on this 3 day of December, 2013.

KAREN E. RUSHING, CLERK Clerk of the Circuit Court (SEAL) By: G. Kopinsky Deputy Clerk

Albertelli Law P.O. Box 23028 Tampa, FL 33623 EF-13-112467 December 13, 20, 2013 13-05789S

SAVE TIME E-mail your Legal Notice legal@businessobserverfl.com Wednesday Noon Deadline • Friday Publication Business Observer

SECOND INSERTION

NOTICE OF FORECLOSURE SALE
IN THE CIRCUIT COURT OF THE
12TH JUDICIAL CIRCUIT IN
AND FOR SARASOTA COUNTY,
FLORIDA

CASE NO.: 2010 CA 008225 NC
BANK OF AMERICA, N.A.,
Plaintiff, vs.
SHEILA LEE, et al.

Defendants,
NOTICE IS HEREBY GIVEN pursuant to a Final Judgment of Foreclosure dated August 26, 2013, entered in Civil Case No.: 2010 CA 008225 NC of the 12th Judicial Circuit in Sarasota, Sarasota County, Florida, Karen E. Rushing, the Clerk of the Court, will sell to the highest and best bidder for cash online at www.sarasota.realforeclose.com at 9:00 A.M. EST on the 27th day of December, 2013 the following described property as set forth in said Final Judgment, to-wit:

LOT 3083, STONEYWOOD COVE, ACCORDING TO THE PLAT THEREOF, AS RECORDED IN PLAT BOOK 45, PAGE 36, OF THE PUBLIC RECORDS OF SARASOTA COUNTY, FLORIDA

Any person claiming an interest in the surplus from the sale, if any, other than the property owner as of the date of the lis pendens must file a claim within 60 days after the sale.

If you are a person with a disability who needs any accommodation in order to participate in this proceeding, you are entitled, at no cost to you, to the provision of certain assistance. Please contact the Sarasota County Jury Office, P.O. Box 3079, Sarasota, Florida 34230-3079, (941)861-7400, at least seven (7) days before your scheduled court appearance, or immediately upon receiving this notification if the time before the scheduled appearance is less than seven (7) days; if you are hearing or voice impaired, call 711.

Dated this 6th day of December, 2013.

By: /s/ Maria Fernandez-Gomez
Maria Fernandez-Gomez, Esq.
Fla. Bar No. 998494

TRIPP SCOTT, P.A.
Attorneys for Plaintiff
110 S.E. Sixth St.,
15th Floor
Fort Lauderdale, FL 33301
Telephone (954) 765-2999
Facsimile (954) 761 8475
Email: mfg@trippscott.com
11-001239
December 13, 20, 2013 13-05837S

SECOND INSERTION

NOTICE OF SALE
IN THE CIRCUIT COURT OF THE
TWELFTH JUDICIAL CIRCUIT,
IN AND FOR SARASOTA COUNTY,
FLORIDA

CASE NO.: 2009 CA 009089
BANK OF AMERICA, N.A.,
Plaintiff, vs.
STEVEN J. REDDING, et al.,
Defendants,

NOTICE IS GIVEN that, in accordance with the Plaintiff's Final Judgment of Foreclosure entered on October 25, 2013 in the above-styled case, I will sell to the highest and best bidder for cash on January 8, 2014 at 9:00 A.M., at www.sarasota.realforeclose.com, the following described property:

LOT 22, BLOCK 10 OF PORT CHARLOTTE SUBDIVISION, ACCORDING TO THE PLAT THEREOF AS RECORDED IN PLAT BOOK 10, PAGE(S) 95, 95A THROUGH 95D, OF THE PUBLIC RECORDS OF SARASOTA COUNTY, FLORIDA.

Property Address: 6189 Jordan St., North Port, FL 34287

ANY PERSON CLAIMING AN INTEREST IN THE SURPLUS FROM THE SALE, IF ANY, OTHER THAN THE PROPERTY OWNER AS OF THE DATE OF THE LIS PENDENS MUST FILE A CLAIM WITHIN 60 DAYS AFTER THE SALE.

If you are a person with a disability who needs any accommodation in order to participate in this proceeding, you are entitled, at no cost to you, to the provision of certain assistance. Please contact the Sarasota County Jury Office, P.O. Box 3079, Sarasota, Florida 34230-3079, (941)861-7400, at least seven (7) days before your scheduled court appearance, or immediately upon receiving this notification if the time before the scheduled appearance is less than seven (7) days; if you are hearing or voice impaired, call 711.

Dated: December 9, 2013.
Kelley L. Church, Esquire
Florida Bar No.: 100194

Quintairos, Prieto, Wood & Boyer, P.A.
255 South Orange Ave.,
Ste. 900
Orlando, FL 32801-3454
(407) 872-6011
(407)872-6012 Facsimile
E-mail: servicecopies@qpwblaw.com
E-mail: khurch@qpwblaw.com
Matter # 61118
December 13, 20, 2013 13-05847S

SECOND INSERTION

NOTICE OF SALE
IN THE CIRCUIT COURT OF THE
TWELFTH JUDICIAL CIRCUIT
IN AND FOR SARASOTA COUNTY,
FLORIDA

CASE NO. 2012 CA 006120 NC
WELLS FARGO BANK, N.A.
Plaintiff, v.
GAETANO SPANO; CASIMINA
SPANO; UNKNOWN TENANT 1;
UNKNOWN TENANT 2; AND ALL
UNKNOWN PARTIES

CLAIMING BY, THROUGH,
UNDER OR AGAINST THE ABOVE
NAMED DEFENDANT(S), WHO
(IS/ARE) NOT KNOWN TO BE
DEAD OR ALIVE, WHETHER
SAID UNKNOWN PARTIES CLAIM
AS HEIRS, DEVISEES, GRANTEES,
ASSIGNEES, LIENORS,
CREDITORS,
TRUSTEES, SPOUSES, OR OTHER
CLAIMANTS;
Defendants.

Notice is hereby given that, pursuant to the Summary Final Judgment of Foreclosure entered on November 18, 2013, in this cause, in the Circuit Court of Sarasota County, Florida, the clerk shall sell the property situated in Sarasota County, Florida, described as:

LOT 29, BLOCK 897, 20TH ADDITION TO PORT CHARLOTTE SUBDIVISION, ACCORDING TO THE PLAT THEREOF, RECORDED IN PLAT BOOK 14, PAGE 8, 8A-8K, OF THE PUBLIC RECORDS OF SARASOTA COUNTY, FLORIDA.

a/k/a 3240 CIRCLEVILLE STREET, NORTH PORT, FL 34286-2946

at public sale, to the highest and best bidder, for cash, online at www.sarasota.realforeclose.com, on February 19, 2014 beginning at 09:00 AM.

If you are a person claiming a right to funds remaining after the sale, you must file a claim with the clerk no later than 60 days after the sale. If you fail to file a claim you will not be entitled to any remaining funds.

If you are a person with a disability who needs any accommodation in order to participate in this proceeding, you are entitled, at no cost to you, to the provision of certain assistance. Please contact the Sarasota County Jury Office, P.O. Box 3079, Sarasota, Florida 34230-3079, (941)861-7400, at least seven (7) days before your scheduled court appearance, or immediately upon receiving this notification if the time before the scheduled appearance is less than seven (7) days; if you are hearing or voice impaired, call 711.

Dated at St. Petersburg, Florida, this 9th day of December 2013.

By: /s/ Angela L. Leiner, Esquire
Angela L. Leiner
FBN#85112

Douglas C. Zahm, P.A.
Designated Email Address:
efiling@dczahm.com
12425 28th Street North, Suite 200
St. Petersburg, FL 33716
Telephone No. (727) 536-4911
Attorney for the Plaintiff
888121651
December 13, 20, 2013 13-05850S

SECOND INSERTION

NOTICE OF SALE
IN THE CIRCUIT COURT OF THE
TWELFTH JUDICIAL CIRCUIT OF
THE STATE OF FLORIDA, IN AND
FOR SARASOTA COUNTY
CIVIL DIVISION
CASE NO.

58-2012-CA-000036-0000-NC
CITIMORTGAGE, INC.,
Plaintiff, vs.

JOAN WISNIEWSKI; UNKNOWN SPOUSE OF JOAN WISNIEWSKI; JOHN WISNIEWSKI; UNKNOWN SPOUSE OF JOHN WISNIEWSKI; IF LIVING, INCLUDING ANY UNKNOWN SPOUSE OF SAID DEFENDANT(S), IF REMARRIED, AND IF DECEASED, THE RESPECTIVE UNKNOWN HEIRS, DEVISEES, GRANTEES, ASSIGNEES, CREDITORS, LIENORS, AND TRUSTEES, AND ALL OTHER PERSONS CLAIMING BY, THROUGH, UNDER OR AGAINST THE NAMED DEFENDANT(S); CITIBANK, NATIONAL ASSOCIATION AS SUCCESSOR BY MERGER TO CFSB, NATIONAL ASSOCIATION AS SUCCESSOR BY MERGER TO CITIBANK, FEDERAL SAVINGS BANK; DISCOVER BANK; WHETHER DISSOLVED OR PRESENTLY EXISTING, TOGETHER WITH ANY GRANTEES, ASSIGNEES, CREDITORS, LIENORS, OR TRUSTEES OF SAID DEFENDANT(S) AND ALL OTHER PERSONS CLAIMING BY, THROUGH, UNDER, OR AGAINST DEFENDANT(S); UNKNOWN TENANT #1; UNKNOWN TENANT #2;
Defendant(s)

Notice is hereby given that, pursuant to a Final Summary Judgment of Foreclosure entered on 11/18/2013 in the

SECOND INSERTION

NOTICE OF SALE
IN THE CIRCUIT COURT OF THE
TWELFTH JUDICIAL CIRCUIT OF
THE STATE OF FLORIDA, IN AND
FOR SARASOTA COUNTY
CIVIL DIVISION
CASE NO.

58-2010-CA-000848-XXXX-NC
TROPICAL FINANCIAL CREDIT
UNION,
Plaintiff, vs.

ARMANDO RAMIREZ;
LETICIA RAMIREZ; IF
LIVING, INCLUDING ANY
UNKNOWN SPOUSE OF SAID
DEFENDANT(S), IF REMARRIED,
AND IF DECEASED, THE
RESPECTIVE UNKNOWN
HEIRS, DEVISEES, GRANTEES,
ASSIGNEES, CREDITORS,
LIENORS, AND TRUSTEES,
AND ALL OTHER PERSONS
CLAIMING BY, THROUGH,
UNDER OR AGAINST THE
NAMED DEFENDANT(S);
TROPICAL FINANCIAL CREDIT
UNION; JOHN DOE; JANE DOE;
Defendant(s)

Notice is hereby given that, pursuant to a Final Summary Judgment of Foreclosure entered on 09/09/2013 in the above styled cause, in the Circuit Court of Sarasota County, Florida, the office of Karen E. Rushing clerk of the circuit court will sell the property situate in Sarasota County, Florida, described as:

EAST 25 OF LOT 21, ALL OF LOTS 22 AND 23 AND LOT 24, LESS AND EXCEPT THAT PORTION AS DESCRIBED IN DEED BOOK 333, PAGE 335, ALL IN BLOCK A, POMS PARK, ACCORDING TO THE PLAT THEREOF RECORDED IN PLAT BOOK 1, PAGE 99 OF THE PUBLIC RECORDS OF SARASOTA COUNTY FLORIDA.

at public sale, to the highest and best bidder, for cash, www.sarasota.realforeclose.com, at 9:00 o'clock, A.M., on January 9, 2014

Any person claiming an interest in the surplus from the sale, if any, other than the property owner as of the date of the lis pendens, must file a claim within 60 days after the sale.

If you are a person with a disability who needs any accommodation in order to participate in this proceeding, you are entitled, at no cost to you, to the provision of certain assistance. Please contact the Sarasota County Jury Office, P.O. Box 3079, Sarasota, Florida 34230-3079, (941)861-7400, at least seven (7) days before your scheduled court appearance, or immediately upon receiving this notification if the time before the scheduled appearance is less than seven (7) days; if you are hearing or voice impaired, call 711.

ATTORNEY FOR PLAINTIFF
By Josh D. Donnelly
Florida Bar #64788

Date: 12/10/2013
THIS INSTRUMENT PREPARED BY:
Law Offices Of Daniel C. Consuegra
9204 King Palm Drive
Tampa, FL 33619-1328
Phone: 813-915-8660
Attorneys for Plaintiff
88784
December 13, 20, 2013 13-05864S

SECOND INSERTION

NOTICE OF SALE
IN THE CIRCUIT COURT OF THE
TWELFTH JUDICIAL CIRCUIT OF
THE STATE OF FLORIDA, IN AND
FOR SARASOTA COUNTY
CIVIL DIVISION
CASE NO.

58-2012-CA-000005-0000-NC
CITIMORTGAGE, INC.,
Plaintiff, vs.

STEVE O. GRAHAM A/K/A
STEVEN O. GRAHAM;
UNKNOWN SPOUSE OF STEVE
O. GRAHAM A/K/A STEVEN O.
GRAHAM; NADINE GRAHAM;
IF LIVING, INCLUDING ANY
UNKNOWN SPOUSE OF SAID
DEFENDANT(S), IF REMARRIED,
AND IF DECEASED, THE
RESPECTIVE UNKNOWN
HEIRS, DEVISEES, GRANTEES,
ASSIGNEES, CREDITORS,
LIENORS, AND TRUSTEES, AND
ALL OTHER PERSONS CLAIMING
BY, THROUGH, UNDER
OR AGAINST THE NAMED
DEFENDANT(S); UNKNOWN
TENANT #1; UNKNOWN TENANT
#2;
Defendant(s)

Notice is hereby given that, pursuant to a Final Summary Judgment of Foreclosure entered on 08/12/2013 in the above styled cause, in the Circuit Court of Sarasota County, Florida, the office of Karen E. Rushing clerk of the circuit court will sell the property situate in Sarasota County, Florida, described as:

LOT 4, BLOCK 132, OF THE 8TH ADDITION TO PORT CHARLOTTE, A SUBDIVISION ACCORDING TO THE PLAT THEREOF, AS RECORDED IN PLAT BOOK 12, AT PAGES 20, 20-A THROUGH 20-Z-2, OF THE PUBLIC RECORDS OF SARASOTA COUNTY, FLORIDA.

at public sale, to the highest and best bidder, for cash, www.sarasota.realforeclose.com at 9:00 o'clock, A.M., on January 9, 2014

Any person claiming an interest in the surplus from the sale, if any, other than the property owner as of the date of the lis pendens, must file a claim within 60 days after the sale.

If you are a person with a disability who needs any accommodation in order to participate in this proceeding, you are entitled, at no cost to you, to the provision of certain assistance. Please contact the Sarasota County Jury Office, P.O. Box 3079, Sarasota, Florida 34230-3079, (941)861-7400, at least seven (7) days before your scheduled court appearance, or immediately upon receiving this notification if the time before the scheduled appearance is less than seven (7) days; if you are hearing or voice impaired, call 711.

ATTORNEY FOR PLAINTIFF
By Josh D. Donnelly
Florida Bar #64788

Date: 12/10/2013
THIS INSTRUMENT PREPARED BY:
Law Offices Of Daniel C. Consuegra
9204 King Palm Drive
Tampa, FL 33619-1328
Phone: 813-915-8660
Attorneys for Plaintiff
114784
December 13, 20, 2013 13-05858S

SECOND INSERTION

NOTICE OF RESCHEDULED SALE
IN THE CIRCUIT COURT OF THE
TWELFTH JUDICIAL CIRCUIT
IN AND FOR SARASOTA COUNTY,
FLORIDA
CIVIL ACTION
CASE NO.: 2008 CA 006798 NC
DIVISION: A

THE BANK OF NEW YORK AS
TRUSTEE FOR THE
CERTIFICATEHOLDERS CWALT,
INC. ALTERNATIVE LOAN
TRUST 2005-J1, MORTGAGE
PASS-THROUGH CERTIFICATES,
SERIES 2005-J1,
Plaintiff, vs.
MAREK G. KOTOWSKI A/K/A
MAREK KOTOWSKI, et al,
Defendant(s).

NOTICE IS HEREBY GIVEN Pursuant to an Order Rescheduling Foreclosure Sale dated December 6, 2013, and entered in Case No. 2008 CA 006798 NC of the Circuit Court of the Twelfth Judicial Circuit in and for Sarasota County, Florida in which The Bank Of New York As Trustee For The Certificateholders Cwalt, Inc. Alternative Loan Trust 2005-J, mortgage Pass-through Certificates, Series 2005-J1, is the Plaintiff and Irene B. Kotowski a/k/a Irene Kotowski, Marek G. Kotowski a/k/a Marek Kotowski, General Motors Acceptance Corporation, Suntrust Bank, The Villages at Pine Tree HOA, Inc., are defendants, the Sarasota County Clerk of the Circuit Court will sell to the highest and best bidder for cash in/on the Internet: www.sarasota.realforeclose.com, Sarasota County, Florida at 9:00am on the 10th day of January, 2014, the following described property as set forth in said Final Judgment of Foreclosure:

LOT 3097, VILLAGES AT PINE-TREE, PONDEROSA ENCLAVE, AS PER PLAT BOOK 43, PAGE 30, PUBLIC RECORDS OF SARASOTA COUNTY, FLORIDA.

A/K/A 1340 FRASER PINE BOULEVARD, SARASOTA, FL 34240

Any person claiming an interest in the surplus from the sale, if any, other than the property owner as of the date of the Lis Pendens must file a claim within 60 days after the sale.

If you are a person with a disability who needs any accommodation in order to participate in this proceeding, you are entitled, at no cost to you, to the provision of certain assistance. Please contact the Sarasota County Jury Office, P.O. Box 3079, Sarasota, Florida 34230-3079, (941)861-7400, at least seven (7) days before your scheduled court appearance, or immediately upon receiving this notification if the time before the scheduled appearance is less than seven (7) days; if you are hearing or voice impaired, call 711.

Albertelli Law
Attorney for Plaintiff
P.O. Box 23028
Tampa, FL 33623
(813) 221-4743
(813) 221-9171 facsimile
eService: servealaw@albertellilaw.com
BM - 11-76018
December 13, 20, 2013 13-05853S

SECOND INSERTION

NOTICE OF SALE PURSUANT TO
CHAPTER 45
IN THE CIRCUIT COURT OF THE
TWELFTH JUDICIAL CIRCUIT
IN AND FOR SARASOTA COUNTY,
FLORIDA
CIVIL ACTION
CASE NO.: 2012 CA 009336 NC
WELLS FARGO BANK, N.A. AS
TRUSTEE FOR WAMU
MORTGAGE PASS-THROUGH
CERTIFICATES, SERIES
2005-PR4 TRUST,
Plaintiff, vs.

MARIA PIA GIANNINI, et al,
Defendant(s).

NOTICE IS HEREBY GIVEN Pursuant to a Final Judgment of Foreclosure dated December 2, 2013, and entered in Case No. 2012 CA 009336 NC of the Circuit Court of the Twelfth Judicial Circuit in and for Sarasota County, Florida in which Wells Fargo Bank, N.A. as Trustee for WaMu Mortgage Pass-Through Certificates, Series 2005-PR4 Trust, is the Plaintiff and Maria Pia Giannini, American Momentum Bank, successor in interest to LandMark Bank of Florida, L.L. Condominium Association, Inc., Tenant # 1 also known as Holly Lang, Tenant # 2, The Unknown Spouse of Maria Pia Giannini, are defendants, the Sarasota County Clerk of the Circuit Court will sell to the highest and best bidder for cash in/on the Internet: www.sarasota.realforeclose.com, Sarasota County, Florida at 9:00am on the 8th day of January, 2014, the following described property as set forth in said Final Judgment of Foreclosure:

UNIT 10, LOS LAGOS CONDOMINIUM, A CONDOMINIUM ACCORDING TO THE DECLARATION OF CONDOMINIUM RECORDED IN OFFICIAL RE-

CORDS BOOK 1604, PAGES 612 THROUGH 648 AND AMENDMENTS THERETO AND AS PER PLAT THEREOF RECORDED IN CONDOMINIUM BOOK 20, PAGES 46, 46-A THROUGH 46-L AND AMENDED IN CONDOMINIUM BOOK 21, PAGES 12, 12-A THROUGH 12-C AND CONDOMINIUM BOOK 22, PAGES 28, 28-A THROUGH 28-E, OF THE PUBLIC RECORDS OF SARASOTA COUNTY, FLORIDA.

A/K/A 3013 CLARK RD APT 10, SARASOTA, FL 34231-7388

Any person claiming an interest in the surplus from the sale, if any, other than the property owner as of the date of the Lis Pendens must file a claim within 60 days after the sale.

If you are a person with a disability who needs any accommodation in order to participate in this proceeding, you are entitled, at no cost to you, to the provision of certain assistance. Please contact the Sarasota County Jury Office, P.O. Box 3079, Sarasota, Florida 34230-3079, (941)861-7400, at least seven (7) days before your scheduled court appearance, or immediately upon receiving this notification if the time before the scheduled appearance is less than seven (7) days; if you are hearing or voice impaired, call 711.

Albertelli Law
Attorney for Plaintiff
P.O. Box 23028
Tampa, FL 33623
(813) 221-4743
(813) 221-9171 facsimile
eService: servealaw@albertellilaw.com
BM - 003544F01
December 13, 20, 2013 13-05854S

SECOND INSERTION

NOTICE OF FORECLOSURE SALE IN THE CIRCUIT COURT OF THE 12TH JUDICIAL CIRCUIT, IN AND FOR SARASOTA COUNTY, FLORIDA.

CASE No. 2009 CA 013384 NC U.S. BANK NATIONAL ASSOCIATION, AS TRUSTEE FOR HOMEBANC MORTGAGE TRUST 2005-4 MORTGAGE BACKED NOTES, SERIES 2005-4, Plaintiff, vs.

OLGA J. KARASAY, DECEASED, et. al., Defendants.

NOTICE IS HEREBY GIVEN pursuant to an Order or Final Judgment entered in Case No. 2009-CA-013384 NC of the Circuit Court of the 12TH Judicial Circuit in and for SARASOTA County, Florida, wherein, U.S. BANK NATIONAL ASSOCIATION, AS TRUSTEE FOR HOMEBANC MORTGAGE TRUST 2005-4 MORTGAGE BACKED NOTES, SERIES 2005-4, Plaintiff, and, OLGA J. KARASAY, DECEASED, et. al., are Defendants, I will sell to the highest bidder for cash at, FORECLOSURE SALE TO BE CONDUCTED VIA THE INTERNET: WWW.SARASOTA.REALFORECLOSE.COM, at the hour of 9:00 A.M., on the 6TH DAY OF JANUARY, 2014, the following described property:

CONDOMINIUM UNIT 6, BUILDING 906, PARK VIEW CONDOMINIUM, TOGETHER WITH AN UNDIVIDED INTEREST IN THE COMMON ELEMENTS, ACCORDING TO THE DECLARATION OF

CONDOMINIUM THEREOF RECORDED IN INSTRUMENT NO. 2005108535, AS AMENDED FROM TIME TO TIME, OF THE PUBLIC RECORDS OF SARASOTA COUNTY, FLORIDA.

Any person claiming an interest in the surplus from the sale, if any, other than the property owner as of the date of the lis pendens must file a claim within 60 days after the sale.

If you are a person with a disability who needs any accommodation in order to participate in this proceeding, you are entitled, at no cost to you, to the provision of certain assistance. Please contact the Sarasota County Jury Office, P.O. Box 3079, Sarasota, Florida 34230-3079, (941)861-7400, at least seven (7) days before your scheduled court appearance, or immediately upon receiving this notification if the time before the scheduled appearance is less than seven (7) days; if you are hearing or voice impaired, call 711.

DATED this 10 day of Dec, 2013.

By: Michele Clancy, Esq.
Florida Bar No. 498661
GREENSPOON MARDER, P.A.
TRADE CENTRE SOUTH,
SUITE 700
100 WEST CYPRESS CREEK ROAD
FORT LAUDERDALE, FL 33309
Telephone: (954) 343 6273
Hearing Line: (888) 491-1120
Facsimile: (954) 343 6982
Email:
michael.eisenband@gmlaw.com
Email 2: gmforeclosure@gmlaw.com
(19941.1062)
December 13, 20, 2013 13-058655

SECOND INSERTION

NOTICE OF SALE IN THE CIRCUIT COURT OF THE TWELFTH JUDICIAL CIRCUIT IN AND FOR SARASOTA COUNTY, FLORIDA

CASE No.: 58-2012-CA-004398 NC THE BANK OF NEW YORK MELLON FKA THE BANK OF NEW YORK, AS TRUSTEE FOR THE CERTIFICATE HOLDERS OF THE CWMBS INC., CHL MORTGAGE PASS THROUGH TRUST 2005-9, MORTGAGE PASS THROUGH CERTIFICATES, SERIES 2005-9 Plaintiff, v.

CHRISTOPHER FOWDEN; MICHELLE L. FOWDEN; ANY AND ALL UNKNOWN PARTIES CLAIMING BY, THROUGH, UNDER, AND AGAINST THE HEREIN NAMED INDIVIDUAL DEFENDANT(S) WHO ARE NOT KNOWN TO BE DEAD OR ALIVE, WHETHER SAID UNKNOWN PARTIES MAY CLAIM AN INTEREST AS SPOUSES, HEIRS, DEVISEES, GRANTEEES, OR OTHER CLAIMANTS; REGIONS BANK, A FOREIGN CORP. AUTHORIZED TO DO BUSINESS IN THE STATE OF FLORIDA, AS SUCCESSOR BY MERGER TO AMSOUTH BANK, Defendant(s).

NOTICE IS HEREBY GIVEN pursuant to an Order on Plaintiff's Motion to Reset Foreclosure Sale dated November 19, 2013, entered in Civil Case No. 58-2012-CA-004398 NC of the Circuit Court of the Twelfth Judicial Circuit in and for Sarasota County, Florida, wherein the Clerk of the Circuit Court will sell to the highest bidder for cash on the 9th day of January, 2014, at 9:00

a.m. online at the website: https://www.sarasota.realforeclose.com, relative to the following described property as set forth in the Final Judgment, to wit:

LOT 24, BLOCK 217 OF 8TH ADDITION TO PORT CHARLOTTE SUBDIVISION, ACCORDING TO THE PLAT THEREOF AS RECORDED IN PLAT BOOK 12, PAGE(S) 20, OF THE PUBLIC RECORDS OF SARASOTA COUNTY, FLORIDA.

Any person claiming an interest in the surplus from the sale, if any, other than the property owner as of the date of the Lis Pendens must file a claim within 60 days after the sale.

If you are a person with a disability who needs any accommodation in order to participate in this proceeding, you are entitled, at no cost to you, to the provision of certain assistance. Please contact the Sarasota County Jury Office, P.O. Box 3079, Sarasota, Florida 34230-3079, (941)861-7400, at least seven (7) days before your scheduled court appearance, or immediately upon receiving this notification if the time before the scheduled appearance is less than seven (7) days; if you are hearing or voice impaired, call 711.

By: Stephen Orsillo, Esq., FBN: 89377
9409 Philadelphia Road
Baltimore, Maryland 21237
Mailing Address:
Morris/Hardwick/Schneider, LLC
5110 Eisenhower Blvd., Suite 302A
Tampa, Florida 33634
Customer Service (866)-503-4930
MHSinb@closingsource.net
FL-97004953-11
9272473
December 13, 20, 2013 13-058665

SECOND INSERTION

NOTICE OF SALE IN THE CIRCUIT COURT OF THE TWELFTH JUDICIAL CIRCUIT OF THE STATE OF FLORIDA, IN AND FOR SARASOTA COUNTY CIVIL DIVISION

CASE NO. 58-2012-CA-003550-XXXX-NC CITIMORTGAGE, INC., Plaintiff, vs.

JOHN H. BALL; UNKNOWN SPOUSE OF JOHN H. BALL; IF LIVING, INCLUDING ANY UNKNOWN SPOUSE OF SAID DEFENDANT(S), IF REMARRIED, AND IF DECEASED, THE RESPECTIVE UNKNOWN HEIRS, DEVISEES, GRANTEEES, ASSIGNEES, CREDITORS, LIENORS, AND TRUSTEES, AND ALL OTHER PERSONS CLAIMING BY, THROUGH, UNDER, OR AGAINST THE NAMED DEFENDANT(S); GULF COAST ASSISTANCE, LLC; IBERIABANK; CAPITAL ONE BANK; WHETHER DISSOLVED OR PRESENTLY EXISTING, TOGETHER WITH ANY GRANTEEES, ASSIGNEES, CREDITORS, LIENORS, OR TRUSTEES OF SAID DEFENDANT(S) AND ALL OTHER PERSONS CLAIMING BY, THROUGH, UNDER, OR AGAINST DEFENDANT(S); UNKNOWN TENANT #1; UNKNOWN TENANT #2; Defendant(s)

Notice is hereby given that, pursuant to a Final Summary Judgment of Foreclosure entered on 09/10/2013 in the above styled cause, in the Circuit Court of Sarasota County, Florida, the office of Karen E. Rushing clerk of the circuit

court will sell the property situate in Sarasota County, Florida, described as: LOTS 16, 17, 18 AND 19, BLOCK 14, BEVERLY TERRACE, UNIT NO. 2, ACCORDING TO THE PLAT THEREOF, AS RECORDED IN PLAT BOOK 2, PAGE 126, OF THE PUBLIC RECORDS OF SARASOTA COUNTY, FLORIDA.

at public sale, to the highest and best bidder, for cash, www.sarasota.realforeclose.com at 9:00 o'clock, A.M., on January 10, 2014

Any person claiming an interest in the surplus from the sale, if any, other than the property owner as of the date of the lis pendens, must file a claim within 60 days after the sale.

If you are a person with a disability who needs any accommodation in order to participate in this proceeding, you are entitled, at no cost to you, to the provision of certain assistance. Please contact the Sarasota County Jury Office, P.O. Box 3079, Sarasota, Florida 34230-3079, (941)861-7400, at least seven (7) days before your scheduled court appearance, or immediately upon receiving this notification if the time before the scheduled appearance is less than seven (7) days; if you are hearing or voice impaired, call 711.

ATTORNEY FOR PLAINTIFF
By Josh D. Donnelly
Florida Bar #64788
Date: 12/10/2013
THIS INSTRUMENT PREPARED BY:
Law Offices Of Daniel C. Consuegra
9204 King Palm Drive
Tampa, FL 33619-1328
Phone: 813-915-8660
Attorneys for Plaintiff
91696
December 13, 20, 2013 13-058595

AMENDED NOTICE OF FORECLOSURE SALE IN THE CIRCUIT COURT IN AND FOR SARASOTA COUNTY, FLORIDA

CASE NO.: 2009-CA-005476-NC WELLS FARGO, Plaintiff, vs. GWEN GOLD, et. al., Defendants.

NOTICE is hereby given that the Clerk of the Circuit Court of Sarasota County, Florida, will on the 9th day of January 2014 at 9am online at: www.sarasota.realforeclose.com in accordance with Chapter 45 Florida Statutes, offer for sale and sell at public outcry to the highest and best bidder for cash, the following-described property situate in Sarasota County, Florida:

LOTS 31 AND 32, less that portion of said LOTS described as

NOTICE OF FORECLOSURE SALE IN THE CIRCUIT COURT OF THE TWELFTH JUDICIAL CIRCUIT IN AND FOR SARASOTA COUNTY, FLORIDA

CIVIL ACTION CASE NO.: 2013-CA-004385-NC DIVISION: C

WELLS FARGO BANK, N.A., Plaintiff, vs. THE UNKNOWN HEIRS, DEVISEES, GRANTEEES, ASSIGNEES, LIENORS, CREDITORS, TRUSTEES, OR OTHER CLAIMANTS CLAIMING BY, THROUGH, UNDER, OR AGAINST JEAN M. LEINBACH A/K/A JEAN MARGARET LEINBACH, DECEASED, et al, Defendant(s).

NOTICE IS HEREBY GIVEN pursuant to a Final Judgment of Mortgage Foreclosure dated December 2, 2013 and entered in Case No. 2013-CA-004385-NC of the Circuit Court of the TWELFTH Judicial Circuit in and for SARASOTA County, Florida wherein WELLS FARGO BANK, N.A. is the Plaintiff and THE UNKNOWN HEIRS, DEVISEES, GRANTEEES, ASSIGNEES, LIENORS, CREDITORS, TRUSTEES, OR OTHER CLAIM-

ants claiming by, through, under, or against JEAN M. LEINBACH A/K/A JEAN MARGARET LEINBACH, DECEASED; JEFFREY R. LEINBACH AS AN HEIR OF THE ESTATE OF JEAN M. LEINBACH A/K/A JEAN MARGARET LEINBACH, DECEASED; AMY MELISSA MARQUIS AS AN HEIR OF THE ESTATE OF JEAN M. LEINBACH A/K/A JEAN MARGARET LEINBACH, DECEASED; JAMES C. LEINBACH AS AN HEIR OF THE ESTATE OF JEAN M. LEINBACH A/K/A JEAN MARGARET LEINBACH, DECEASED; JACQUELINE ANN LEINBACH A/K/A JACQUELINE LEINBACH AS AN HEIR OF THE ESTATE OF JEAN M. LEINBACH A/K/A JEAN MARGARET LEINBACH, DECEASED; JAMES C. LEINBACH AS PERSONAL REPRESENTATIVE OF THE ESTATE OF JEAN M. LEINBACH A/K/A JEAN MARGARET LEINBACH, DECEASED; ANY AND ALL UNKNOWN PARTIES CLAIMING BY, THROUGH, UNDER, AND AGAINST THE HEREIN NAMED INDIVIDUAL DEFENDANT(S) WHO ARE NOT KNOWN TO BE DEAD OR ALIVE, WHETHER SAID UNKNOWN PARTIES MAY CLAIM AN INTEREST AS SPOUS-

follows: Commence at the N.W. corner of Lot 32, TWIN OAK SUBDIVISION, recorded in Plat Book 8, Page 34, Public Records of Sarasota County, Florida; thence S 0 degrees 15' E., 142.00' to the S.W. Corner of LOT 31 of said subdivision thence N. 89 degrees 47' E. along the S. line of said Lot 31, 38.52' for a Point of Beginning; thence N. 0 degrees 15' W., 53.00' thence N. 89 degrees 47' E., 10.48' thence N. 59 degrees 37' E., 30.00'; thence N.2 degrees 14' 40' E., 52.25' to the Point of Intersection with the Westerly right of way line of Winding Way East (50' Wide); thence S. 33 degrees 51' E., along said right of way, 144.47' to the S. E. corner of said Lot 31, thence S. 89 degrees 47' W. along the South

line of said Lot 31 118.58' to the Point of Beginning; being part of LOTS 31 and 32, TWIN OAK POND SUBDIVISION. pursuant to the Final Judgment entered in a case pending in said Court, the style of which is indicated above.

Any person or entity claiming an interest in the surplus, if any, resulting from the foreclosure sale, other than the property owner as of the date of the Lis Pendens, must file a claim on same with the Clerk of Court within 60 days after the foreclosure sale.

If you are a person with a disability who needs any accommodation in order to participate in this proceeding, you are entitled, at no cost to you, to the provision of certain assistance. Please contact the Sarasota County Jury Office, P.O. Box 3079, Sarasota, Florida 34230-3079, (941)861-7400,

ES, HEIRS, DEVISEES, GRANTEEES, OR OTHER CLAIMANTS; MARK-KEY CANCER CENTER FOUNDATION, INC. AS AN HEIR OF THE ESTATE OF JEAN M. LEINBACH A/K/A JEAN MARGARET LEINBACH, DECEASED; THE LEUKEMIA & LYMPHOMA SOCIETY, INC. AS AN HEIR OF THE ESTATE OF JEAN M. LEINBACH A/K/A JEAN MARGARET LEINBACH, DECEASED; SUNCOAST HUMANE SOCIETY, INC. AS AN HEIR OF THE ESTATE OF JEAN M. LEINBACH A/K/A JEAN MARGARET LEINBACH, DECEASED; UNITED NEGRO COLLEGE FUND, INC.; TENANT #1, TENANT #2, TENANT #3, and TENANT #4 are the Defendants, The Clerk will sell to the highest and best bidder for cash at WWW.SARASOTA.REALFORECLOSE.COM at 9:00AM, on the 6th day of January, 2014, the following described property as set forth in said Final Judgment:

LOT 10, BLOCK 2517, FIFTIETH ADDITION TO PORT CHARLOTTE SUBDIVISION, ACCORDING TO THE PLAT THEREOF RECORDED IN PLAT BOOK 21, PAGE 7, OF THE PUBLIC RECORDS OF SARASOTA COUNTY, FLORIDA.

SECOND INSERTION

NOTICE OF SALE PURSUANT TO CHAPTER 45 IN THE CIRCUIT COURT OF THE 12TH JUDICIAL CIRCUIT IN AND FOR SARASOTA COUNTY, FLORIDA

CASE NO. 2009 CA 013672 NC DLJ MORTGAGE CAPITAL, INC., Plaintiff, vs- LANCE CHRISTIANSON A/K/A LANCE K. CHRISTIANSON A/K/A LANCE KENNETH CHRISTIANSON, etc., et al., Defendants.

NOTICE IS HEREBY GIVEN pursuant to an Order granting Plaintiff's Motion to Reschedule Sale dated December 5, 2013, entered in the above captioned action, CASE NO.2009-CA-013672 NC, The Clerk of the Court will sell to the highest and best bidder for cash by electronic sale beginning at 9:00 a.m. at www.sarasota.realforeclose.com, on January 21, 2014, the following described property as set forth in said final judgment, to-wit:

LOT 38, RIVER FOREST, ACCORDING TO THE PLAT THEREOF RECORDED IN PLAT BOOK 8, PAGES 114 AND 114A, OF THE PUBLIC RECORDS OF SARASOTA COUNTY, FLORIDA

ANY PERSON CLAIMING AN INTEREST IN THE SURPLUS FROM THE SALE, IF ANY, OTHER THAN THE PROPERTY OWNER AS OF THE DATE OF THE LIS PENDENS MUST FILE A CLAIM WITHIN 60 DAYS AFTER THE SALE.

If you are a person with a disability who needs any accommodation in order to participate in this proceeding, you are entitled, at no cost to you, to the provision of certain assistance. Please contact the Sarasota County Jury Office, P.O. Box 3079, Sarasota, Florida 34230-3079, (941)861-7400, at least seven (7) days before your scheduled court appearance, or immediately upon receiving this notification if the time before the scheduled appearance is less than seven (7) days; if you are hearing or voice impaired, call 711.

DATED this December 9, 2013.
By: Eric R. Schwartz, Esq., FBN: 249041
eschwartz@weitzschwartz.com
Steven C. Weitz, Esq., FBN: 788341
stevenweitz@weitzschwartz.com
Michael N. Hosford, Esq., FBN: 20960
mhosford@weitzschwartz.com
WEITZ & SCHWARTZ, P.A.
Attorneys for Plaintiff
900 S. E. 3rd Avenue, Suite 204
Fort Lauderdale, FL 33316
(954) 468-0016
December 13, 20, 2013 13-058495

at least seven (7) days before your scheduled court appearance, or immediately upon receiving this notification if the time before the scheduled appearance is less than seven (7) days; if you are hearing or voice impaired, call 711

DATED this 10 day of Dec., 2013.
Matthew R. Stubbs Esq.
Florida Bar No. 102871
Morgan B. Lea, Esquire
Florida Bar No: 96405
BUTLER & HOSCH, P.A.
3185 South Conway Road,
Suite E
Orlando, Florida 32812
Telephone: (407) 381-5200
Fax: (407) 381-5577
ml96405@butlerandhosch.com
FLPleadings@butlerandhosch.com
B&H # 333390
December 13, 20, 2013 13-058555

IDA.

A/K/A 6751 HIGDON ROAD, NORTH PORT, FL 34287-5556
Any person claiming an interest in the surplus from the sale, if any, other than the property owner as of the date of the Lis Pendens must file a claim within sixty (60) days after the sale.

If you are a person with a disability who needs any accommodation in order to participate in this proceeding, you are entitled, at no cost to you, to the provision of certain assistance. Please contact the Sarasota County Jury Office, P.O. Box 3079, Sarasota, Florida 34230-3079, (941)861-7400, at least seven (7) days before your scheduled court appearance, or immediately upon receiving this notification if the time before the scheduled appearance is less than seven (7) days; if you are hearing or voice impaired, call 711.

By: Roberto D. DeLeon
Florida Bar No. 0093901
Ronald R Wolfe & Associates, P.L.
P.O. Box 25018
Tampa, Florida 33622-5018
(813) 251-4766
(813) 251-1541 Fax
F13005060
December 13, 20, 2013 13-058695

SECOND INSERTION

NOTICE OF SALE IN THE CIRCUIT COURT OF THE TWELFTH JUDICIAL CIRCUIT OF THE STATE OF FLORIDA, IN AND FOR SARASOTA COUNTY CIVIL DIVISION

CASE NO. 58-2012-CA-007928-0000-NC NATIONSTAR MORTGAGE LLC, Plaintiff, vs. MICHAEL C. MUSE; UNKNOWN SPOUSE OF MICHAEL C. MUSE; JAMIE A. MUSE; UNKNOWN SPOUSE OF JAMIE A. MUSE; CITY OF NORTH PORT; UNKNOWN TENANT #1; UNKNOWN TENANT #2; Defendant(s)

Notice is hereby given that, pursuant to a Final Summary Judgment of Foreclosure entered on 09/23/2013 in the above-styled cause, in the Circuit Court of Sarasota County, Florida, the office of Karen E. Rushing clerk of the circuit court will sell the property situate in Sarasota County, Florida, described as: LOTS 18 AND 19, BLOCK 738, 12TH ADDITION TO PORT CHARLOTTE SUBDIVISION, ACCORDING TO THE PLAT THEREOF, AS RECORDED IN PLAT BOOK 13, PAGES 8, 8A THROUGH 8V, OF THE PUBLIC RECORDS OF SARASOTA COUNTY, FLORIDA.

at public sale, to the highest and best bidder, for cash, www.sarasota.realforeclose.com at 9:00 o'clock, A.M., on January 7, 2014

Any person claiming an interest in the surplus from the sale, if any, other than the property owner as of the date of the lis pendens, must file a claim within 60 days after the sale.

If you are a person with a disability who needs any accommodation in order to participate in this proceeding, you are entitled, at no cost to you, to the provision of certain assistance. Please contact the Sarasota County Jury Office, P.O. Box 3079, Sarasota, Florida 34230-3079, (941)861-7400, at least seven (7) days before your scheduled court appearance, or immediately upon receiving this notification if the time before the scheduled appearance is less than seven (7) days; if you are hearing or voice impaired, call 711.

ATTORNEY FOR PLAINTIFF
By Josh D. Donnelly
Florida Bar #64788
Date: 12/10/2013
THIS INSTRUMENT PREPARED BY:
Law Offices Of Daniel C. Consuegra
9204 King Palm Drive
Tampa, FL 33619-1328
Phone: 813-915-8660
Attorneys for Plaintiff
128359
December 13, 20, 2013 13-058625

SECOND INSERTION

NOTICE OF SALE IN THE CIRCUIT COURT OF THE TWELFTH JUDICIAL CIRCUIT OF THE STATE OF FLORIDA, IN AND FOR SARASOTA COUNTY CIVIL DIVISION

CASE NO. 58-2012-CA-006410-0000-NC JPMORGAN CHASE BANK, NATIONAL ASSOCIATION, Plaintiff, vs. JAMES J. DIETRICH JR.; UNKNOWN SPOUSE OF JAMES J. DIETRICH JR.; MARY ANN DIETRICH A/K/A MARY A. DIETRICH; UNKNOWN SPOUSE OF MARY ANN DIETRICH A/K/A MARY A. DIETRICH; BANK OF AMERICA, N.A.; HARBOUR CIRCLE AT LONGBOAT KEY CLUB ASSOCIATION, INC.; UNKNOWN TENANT #1; UNKNOWN TENANT #2; Defendant(s)

Notice is hereby given that, pursuant to a Final Summary Judgment of Foreclosure entered on 12/02/2013 in the above-styled cause, in the Circuit Court of Sarasota County, Florida, the office of Karen E. Rushing clerk of the circuit court will sell the property situate in Sarasota County, Florida, described as: LOT 13, HARBOUR OAKS II, ACCORDING TO THE PLAT THEREOF, AS RECORDED IN PLAT BOOK 30, PAGES 35 AND 35A, INCLUSIVE OF THE PUB-

SECOND INSERTION

LIC RECORDS OF SARASOTA COUNTY, FLORIDA.

at public sale, to the highest and best bidder, for cash, www.sarasota.realforeclose.com at 9:00 o'clock, A.M., on January 7, 2014

Any person claiming an interest in the surplus from the sale, if any, other than the property owner as of the date of the lis pendens, must file a claim within 60 days after the sale.

If you are a person with a disability who needs any accommodation in order to participate in this proceeding, you are entitled, at no cost to you, to the provision of certain assistance. Please contact the Sarasota County Jury Office, P.O. Box 3079, Sarasota, Florida 34230-3079, (941)861-7400, at least seven (7) days before your scheduled court appearance, or immediately upon receiving this notification if the time before the scheduled appearance is less than seven (7) days; if you are hearing or voice impaired, call 711.
ATTORNEY FOR PLAINTIFF
By Josh D. Donnelly
Florida Bar #64788
Date: 12/10/2013
THIS INSTRUMENT PREPARED BY:
Law Offices Of Daniel C. Consuegra
9204 King Palm Drive
Tampa, FL 33619-1328
Phone: 813-915-8660
Attorneys for Plaintiff
108906
December 13, 20, 2013 13-058615

SECOND INSERTION

NOTICE OF FORECLOSURE SALE IN THE CIRCUIT COURT OF THE TWELFTH JUDICIAL CIRCUIT IN AND FOR SARASOTA COUNTY, FLORIDA

CIVIL ACTION CASE NO.: 58-2010-CA-000583-NC DIVISION: A BANK OF AMERICA, N.A., Plaintiff, vs. NORA R. VOELL, et al, Defendant(s).

NOTICE IS HEREBY GIVEN pursuant to a Final Judgment of Mortgage Foreclosure dated December 3, 2013 and entered in Case No. 58-2010-CA-000583-NC of the Circuit Court of the TWELFTH Judicial Circuit in and for SARASOTA County, Florida wherein BANK OF AMERICA, N.A. is the Plaintiff and NORA R VOELL; are the Defendants, The Clerk will sell to the highest and best bidder for cash at WWW.SARASOTA.REALFORECLOSE.COM at 9:00AM, on the 10th day of January, 2014, the following described property as set forth in said Final Judgment:

LOT 2, BLOCK 504, 11TH ADDITION TO PORT CHARLOTTE SUBDIVISION, ACCORDING TO THE PLAT THEREOF, AS RECORDED IN PLAT BOOK 13, PAGES 2 AND 2A TO 2I, INCLUSIVE,

SECOND INSERTION

OF THE PUBLIC RECORDS OF SARASOTA COUNTY, FLORIDA.

A/K/A 3515 MONFERO AVENUE, NORTH PORT, FL 34286
Any person claiming an interest in the surplus from the sale, if any, other than the property owner as of the date of the Lis Pendens must file a claim within sixty (60) days after the sale.

If you are a person with a disability who needs any accommodation in order to participate in this proceeding, you are entitled, at no cost to you, to the provision of certain assistance. Please contact the Sarasota County Jury Office, P.O. Box 3079, Sarasota, Florida 34230-3079, (941)861-7400, at least seven (7) days before your scheduled court appearance, or immediately upon receiving this notification if the time before the scheduled appearance is less than seven (7) days; if you are hearing or voice impaired, call 711.

By: J. Bennett Kitterman
Florida Bar No. 98636
Ronald R Wolfe & Associates, P.L.
P.O. Box 25018
Tampa, Florida 33622-5018
(813) 251-4766
(813) 251-1541 Fax
F10003082
December 13, 20, 2013 13-058685



SECOND INSERTION

RE-NOTICE OF FORECLOSURE SALE IN THE CIRCUIT COURT OF THE 12TH JUDICIAL CIRCUIT, IN AND FOR SARASOTA COUNTY, FLORIDA
CIVIL DIVISION
CASE NO. 2013 CA 001793 NC
FEDERAL NATIONAL MORTGAGE ASSOCIATION ("FNMA")
Plaintiff, vs.
AUDREY MAYO; et al;
Defendants.

NOTICE IS HEREBY GIVEN pursuant to an Order Rescheduling Foreclosure Sale dated 19th day of November, 2013, and entered in Case No. 2013 CA 001793 NC, of the Circuit Court of the 12th Judicial Circuit in and for SARASOTA County, Florida. FEDERAL NATIONAL MORTGAGE ASSOCIATION ("FNMA") is Plaintiff and AUDREY MAYO; UNKNOWN SPOUSE OF AUDREY MAYO; TAMYRA MAYO; ROBERT WAYNE MAYO A/K/A ROBERT W. MAYO; UNKNOWN PERSON(S) IN POSSESSION OF THE SUBJECT PROPERTY; SUNTRUST BANK; VENICE PALMS HOMEOWNERS ASSOCIATION, INC.; are defendants. The Clerk of Court will sell to the highest and best bidder for cash by electronic sale at: www.sarasota.realforeclose.com, at 9:00 A.M., on the 30th day of December, 2013, the following described property as set forth in said Final Judgment, to wit:

LOT 111, VENICE PALMS, PHASE I, ACCORDING TO THE PLAT THEREOF RECORDED IN PLAT BOOK 40, PAGE(S) 7, OF THE PUBLIC RECORDS OF SARASOTA COUNTY, FLORIDA.

A person claiming an interest in the surplus from the sale, if any, other than the property owner as of the date of the lis pendens must file a claim within 60 days after the sale.

If you are a person with a disability who needs any accommodation in order to participate in this proceeding, you are entitled, at no cost to you, to the provision of certain assistance. Please contact the Sarasota County Jury Office, P.O. Box 3079, Sarasota, Florida 34230-3079, (941)861-7400, at least seven (7) days before your scheduled court appearance, or immediately upon receiving this notification if the time before the scheduled appearance is less than seven (7) days; if you are hearing or voice impaired, call 711.

Dated this 3rd day of December, 2013.

By: Stacy D. Robins, Esq.
Bar. No.: 008079

Submitted by:
Kahane & Associates, P.A.
8201 Peters Road, Ste. 3000
Plantation, FL 33324
Telephone: (954) 382-3486
Telefacsimile: (954) 382-5380
Designated service email:
notice@kahaneandassociates.com
File No.: 13-00028 LBPS
December 13, 20, 2013 13-05797S

SECOND INSERTION

NOTICE OF SALE IN THE CIRCUIT COURT OF THE TWELFTH JUDICIAL CIRCUIT OF THE STATE OF FLORIDA, IN AND FOR SARASOTA COUNTY
CIVIL DIVISION
CASE NO.

58-2009-CA-011028-XXXA-NC
PNC BANK, NATIONAL ASSOCIATION,
Plaintiff, vs.
JOSEPH P. LAMIELLE; THE UNKNOWN SPOUSE OF JOSEPH P. LAMIELLE; IF LIVING, INCLUDING ANY UNKNOWN SPOUSE OF SAID DEFENDANT(S), IF REMARRIED, AND IF DECEASED, THE RESPECTIVE UNKNOWN HEIRS, DEVISEES, GRANTEES, ASSIGNEES, CREDITORS, LIENORS, AND TRUSTEES, AND ALL OTHER PERSONS CLAIMING BY, THROUGH, UNDER OR AGAINST THE NAMED DEFENDANT(S); UNKNOWN TENANT #1; UNKNOWN TENANT #2;
Defendant(s)

Notice is hereby given that, pursuant to a Final Summary Judgment of Foreclosure entered on 11/18/2013 in the above-styled cause, in the Circuit Court of Sarasota County, Florida, the office of Karen E. Rushing clerk of the circuit court will sell the property situate in Sarasota County, Florida, described as: LOT 76, AMBERLEA, ACCORDING TO THE PLAT THEREOF, AS RECORDED IN PLAT BOOK 32, PAGE 23, OF THE PUBLIC RECORDS OF SARASOTA COUNTY, FLORIDA.

at public sale, to the highest and best bidder, for cash, www.sarasota.realforeclose.com at 9:00 o'clock, A.M., on January 3, 2014

Any person claiming an interest in the surplus from the sale, if any, other than the property owner as of the date of the lis pendens, must file a claim within 60 days after the sale.

If you are a person with a disability who needs any accommodation in order to participate in this proceeding, you are entitled, at no cost to you, to the provision of certain assistance. Please contact the Sarasota County Jury Office, P.O. Box 3079, Sarasota, Florida 34230-3079, (941)861-7400, at least seven (7) days before your scheduled court appearance, or immediately upon receiving this notification if the time before the scheduled appearance is less than seven (7) days; if you are hearing or voice impaired, call 711.

ATTORNEY FOR PLAINTIFF
By Josh D. Donnelly
Florida Bar #64788

Date: 12/10/2013
THIS INSTRUMENT PREPARED BY:
Law Offices Of Daniel C. Consuegra
9204 King Palm Drive
Tampa, FL 33619-1328
Phone: 813-915-8660
Attorneys for Plaintiff
44728
December 13, 20, 2013 13-05863S

SECOND INSERTION

AMENDED NOTICE OF FORECLOSURE SALE IN THE CIRCUIT COURT OF THE TWELFTH JUDICIAL CIRCUIT IN AND FOR SARASOTA COUNTY, FLORIDA
GENERAL JURISDICTION DIVISION

CASE NO. 2012 CA 004454 NC
DEUTSCHE BANK NATIONAL TRUST COMPANY, AS INDENTURE TRUSTEE FOR AMERICAN HOME MORTGAGE INVESTMENT TRUST 2006-1,
Plaintiff, vs.
KENNETH REEVES A/K/A KENNETH B. REEVES, et.al.
Defendant(s).

NOTICE IS HEREBY GIVEN pursuant to a Final Judgment of Foreclosure dated October 16, 2013, and entered in 2012 CA 004454 NC of the Circuit Court of the Twelfth Judicial Circuit in and for Sarasota County, Florida, wherein DEUTSCHE BANK NATIONAL TRUST COMPANY, AS INDENTURE TRUSTEE FOR AMERICAN HOME MORTGAGE INVESTMENT TRUST 2006-1, is the Plaintiff and KENNETH REEVES A/K/A KENNETH B. REEVES; REGIONS BANK, SUCCESSOR BY MERGER TO AMSOUTH BANK; UNKNOWN TENANT #1 N/K/A ASHLEY MCCLLOUD; UNKNOWN TENANT #2 are the Defendant(s). Karen Rushing as the Clerk of the Circuit Court will sell to the highest and best bidder for cash, www.sarasota.realforeclose.com, at 09:00 AM on December 26, 2013, the following described property as set forth in said Final Judgment, to wit:

LOT 46, OF THE MEADOWS, UNIT 4, ACCORDING TO THE PLAT THEREOF, AS RECORDED IN PLAT BOOK 25, PAGES 9, 9A, TO 9D, INCLUSIVE, OF THE PUBLIC RECORDS OF SARASOTA COUNTY, FLORIDA.

Any person claiming an interest in the surplus from the sale, if any, other than the property owner as of the date of the lis pendens must file a claim within 60 days after the sale.

If you are a person with a disability who needs any accommodation in order to participate in this proceeding, you are entitled, at no cost to you, to the provision of certain assistance. Please contact the Sarasota County Jury Office, P.O. Box 3079, Sarasota, Florida 34230-3079, (941)861-7400, at least seven (7) days before your scheduled court appearance, or immediately upon receiving this notification if the time before the scheduled appearance is less than seven (7) days; if you are hearing or voice impaired, call 711.

Dated this 5th day of December, 2013.

By: Liana R. Hall
FL Bar No. 73813
for Nicole Ramjantn
Florida Bar: 89204

Robertson, Anschutz & Schneid, PL
Attorneys for Plaintiff
6409 Congress Avenue, Suite 100
Boca Raton, Florida 33487
12-05415
December 13, 20, 2013 13-05812S

SECOND INSERTION

NOTICE OF FORECLOSURE SALE IN THE CIRCUIT COURT OF THE TWELFTH JUDICIAL CIRCUIT IN AND FOR SARASOTA COUNTY, FLORIDA
CIVIL ACTION
CASE NO.: 2009-CA-010922-NC
DIVISION: A

HSBC BANK USA, NATIONAL ASSOCIATION AS TRUSTEE FOR WELLS FARGO ASSET SECURITIES CORPORATION, MORTGAGE ASSET-BACKED PASS-THROUGH CERTIFICATES, SERIES 2007-PA1,
Plaintiff, vs.
JOSEPH A. RIESZER, et al,
Defendant(s).

NOTICE IS HEREBY GIVEN pursuant to a Final Judgment of Mortgage Foreclosure dated December 2, 2013 and entered in Case No. 2009-CA-010922-NC of the Circuit Court of the Twelfth Judicial Circuit in and for SARASOTA County, Florida wherein HSBC BANK USA, NATIONAL ASSOCIATION AS TRUSTEE FOR WELLS FARGO ASSET SECURITIES CORPORATION, MORTGAGE ASSET-BACKED PASS-THROUGH CERTIFICATES, SERIES 2007-PA1 is the Plaintiff and JOSEPH A. RIESZER; MELISSA RIESZER A/K/A MELISSA A. RIESZER; TENANT #1 N/K/A JOEY RIESZER are the Defendants, The Clerk will sell to the highest and best bidder for cash at WWW.SARASOTA.REALFORECLOSE.COM at 9:00AM, on the 1st day of April, 2014, the following described property as set forth in said Final Judgment:

LOT 22, BLOCK 8, FIRST ADDITION TO NORTH PORT CHARLOTTE ESTATES, A SUBDIVISION ACCORDING TO THE PLAT THEREOF, RECORDED IN PLAT BOOK 19, PAGES 29, 29A THROUGH 29J, OF THE PUBLIC RECORDS OF SARASOTA COUNTY, FLORIDA.

A/K/A 6472 ABDELLA LANE, NORTH PORT, FL 34286

Any person claiming an interest in the surplus from the sale, if any, other than the property owner as of the date of the Lis Pendens must file a claim within sixty (60) days after the sale.

If you are a person with a disability who needs any accommodation in order to participate in this proceeding, you are entitled, at no cost to you, to the provision of certain assistance. Please contact the Sarasota County Jury Office, P.O. Box 3079, Sarasota, Florida 34230-3079, (941)861-7400, at least seven (7) days before your scheduled court appearance, or immediately upon receiving this notification if the time before the scheduled appearance is less than seven (7) days; if you are hearing or voice impaired, call 711.

By: Matthew Wolf
Florida Bar No. 92611

Ronald R Wolfe & Associates, P.L.
P.O. Box 25018
Tampa, Florida 33622-5018
(813) 251-4766
(813) 251-1541 Fax
F09070151
December 13, 20, 2013 13-05829S

SECOND INSERTION

NOTICE OF FORECLOSURE SALE IN THE CIRCUIT COURT OF THE TWELFTH JUDICIAL CIRCUIT OF FLORIDA IN AND FOR SARASOTA COUNTY
GENERAL JURISDICTION DIVISION

CASE NO. 2012 CA 000209 NC
BANK OF AMERICA, N.A., AS SUCCESSOR BY MERGER TO BAC HOME LOANS SERVICING, L.P.,
Plaintiff, vs.
LISA D. WALKER, STONEYWOOD COVE COMMUNITY ASSOCIATION, INC., UNKNOWN TENANT IN POSSESSION # 1, UNKNOWN TENANT IN POSSESSION # 2, UNKNOWN SPOUSE OF LISA D WALKER A/K/A LISA WALKER,
Defendants.

NOTICE IS HEREBY GIVEN pursuant to a Summary Final Judgment of Foreclosure entered April 29, 2013 in Civil Case No. 2012 CA 000209 NC of the Circuit Court of the TWELFTH Judicial Circuit in and for Sarasota County, Florida, wherein BANK OF AMERICA, N.A., AS SUCCESSOR BY MERGER TO BAC HOME LOANS SERVICING, L.P. is Plaintiff and LISA D. WALKER, STONEYWOOD COVE COMMUNITY ASSOCIATION, INC., UNKNOWN TENANT IN POSSESSION # 1, UNKNOWN TENANT IN POSSESSION # 2, UNKNOWN SPOUSE OF LISA D WALKER A/K/A LISA WALKER, are Defendants, the Clerk of Court will sell to the highest and best bidder for cash electronically at www.sarasota.realforeclose.com in accordance with Chapter 45, Florida Statutes on the 9th day of January, 2014 at 09:00 AM on the following described property as set forth in said Summary Final Judgment, to-wit:

Lot 3103, Stoneywood Cove, according to the plat thereof as recorded in Plat Book 45, Page 36, of the Public Records of Sarasota County, Florida

Any person claiming an interest in the surplus from the sale, if any, other than the property owner as of the date of the lis pendens, must file a claim within 60 days after the sale.

If you are a person with a disability who needs any accommodation in order to participate in this proceeding, you are entitled, at no cost to you, to the provision of certain assistance. Please contact the Sarasota County Jury Office, P.O. Box 3079, Sarasota, Florida 34230-3079, (941)861-7400, at least seven (7) days before your scheduled court appearance, or immediately upon receiving this notification if the time before the scheduled appearance is less than seven (7) days; if you are hearing or voice impaired, call 711.

H. Michael Solloa, Esq.
Florida Bar No. 37854
for Andrew L. Denzer, Esq.

McCalla Raymer, LLC
Attorney for Plaintiff
225 E. Robinson St. Suite 600
Orlando, FL 32801
Phone: (407) 674-1850
Fax: (321) 248-0420
Email:
MRService@mccallaraymer.com
Fla. Bar No.: 72496
2192680
10-02197-5
December 13, 20, 2013 13-05815S

SECOND INSERTION

NOTICE OF FORECLOSURE SALE IN THE CIRCUIT COURT OF THE TWELFTH JUDICIAL CIRCUIT, IN AND FOR SARASOTA COUNTY, FLORIDA
CIVIL DIVISION
CASE NO.: 2012 CA 005260 NC
DEUTSCHE BANK TRUST COMPANY AMERICAS AS TRUSTEE RALI 2006-QS5
Plaintiff, vs.
NANCY OKUN, et al
Defendants.

NOTICE IS HEREBY GIVEN pursuant to a Summary Final Judgment of foreclosure dated December 02, 2013, and entered in Case No. 2012 CA 005260 NC of the Circuit Court of the TWELFTH Judicial Circuit in and for SARASOTA COUNTY, Florida, wherein DEUTSCHE BANK TRUST COMPANY AMERICAS AS TRUSTEE RALI 2006-QS5, is Plaintiff, and NANCY OKUN, et al are Defendants, the clerk will sell to the highest and best bidder for cash, beginning at 09:00 AM at www.sarasota.realforeclose.com, in accordance with Chapter 45, Florida Statutes, on the 07 day of January, 2014, the following described property as set forth in said Summary Final Judgment, to wit:

Unit 103, Building 5752, THE COLONY AT SABAL TRACE, A CONDOMINIUM, according to the Declaration of Condominium recorded in Official Records Instrument #2005115527, as amended in Official Records Instrument #2005132220, and according to Condominium Book 37, Page 49 through 49G, of the Public Records of Sarasota County, Florida, together with that limited common element Garage 52-5 and Parking Space 52-5, together with an undivided interest in the common elements appurtenant thereto.

Any person claiming an interest in the surplus funds from the sale, if any, other than the property owner as of the date of the lis pendens must file a claim within 60 days after the sale.

If you are a person with a disability who needs any accommodation in order to participate in this proceeding, you are entitled, at no cost to you, to the provision of certain assistance. Please contact the Sarasota County Jury Office, P.O. Box 3079, Sarasota, Florida 34230-3079, (941)861-7400, at least seven (7) days before your scheduled court appearance, or immediately upon receiving this notification if the time before the scheduled appearance is less than seven (7) days; if you are hearing or voice impaired, call 711.

Dated: December 9, 2013

By: /s/ Heather J. Koch
Phelan Hallinan, PLC
Heather J. Koch, Esq.,
Florida Bar No. 89107
Emilio R. Lenzi, Esq.,
Florida Bar No. 0668273

Phelan Hallinan, PLC
Attorneys for Plaintiff
2727 West Cypress Creek Road
Ft. Lauderdale, FL 33309
Tel: 954-462-7000
Fax: 954-462-7001
Service by email:
FL.Service@PhelanHallinan.com
December 13, 20, 2013 13-05845S

SECOND INSERTION

NOTICE OF FORECLOSURE SALE IN THE CIRCUIT COURT OF THE 12TH JUDICIAL CIRCUIT, IN AND FOR SARASOTA COUNTY, FLORIDA
CIVIL DIVISION

CASE NO. 2012-CA-004020 NC
DEUTSCHE BANK NATIONAL TRUST COMPANY, TRUSTEE, ON BEHALF OF THE CERTIFICATEHOLDERS OF MORGAN STANLEY ABS CAPITAL I INC. TRUST 2004-NC3, MORTGAGE PASS THROUGH CERTIFICATES, SERIES 2004-NC3,
Plaintiff, vs.
KEVIN FRICKE, SUCCESSOR TRUSTEE OF THE WILLIAM M. FRICKE, JR. TRUST DATED NOVEMBER 20, 2006; ANY AND ALL UNKNOWN PARTIES CLAIMING BY, THROUGH, UNDER AND AGAINST THE HEREIN NAME INDIVIDUAL DEFENDANTS WHO ARE NOT KNOWN TO BE DEAD OR ALIVE, WHETHER SAID UNKNOWN PARTIES MAY CLAIM AN INTEREST AS SPOUSES, HEIRS, DEVISEES, GRANTEES OR OTHER CLAIMANTS; HERONMERE CONDOMINIUM ASSOCIATION, INC.; UNKNOWN TENANT(S) IN POSSESSION, Defendants.

NOTICE IS HEREBY GIVEN pursuant to a Final Judgment of Foreclosure dated March 4, 2013, and Order Rescheduling Foreclosure Sale dated November 25, 2013, both entered in Case No. 2012-CA-004020 NC, of the Circuit Court of the 4th Judicial Circuit in and for SARASOTA County, Florida. DEUTSCHE BANK NATIONAL TRUST COMPANY, TRUSTEE, ON BEHALF OF THE CERTIFICATEHOLDERS OF MORGAN STANLEY ABS CAPITAL I INC. TRUST 2004-NC3, MORTGAGE PASS THROUGH CERTIFICATES, SERIES 2004-NC3 is Plaintiff and KEVIN FRICKE, SUCCESSOR TRUSTEE OF THE WILLIAM M. FRICKE, JR. TRUST

DATED NOVEMBER 20, 2006; HERONMERE CONDOMINIUM ASSOCIATION, INC.; UNKOWN TENANT(S) IN POSSESSION, are defendants. I will sell to the highest and best bidder for cash via www.sarasota.realforeclose.com, at 9:00 a.m., on the 31st day of December, 2013, the following described property as set forth in said Final Judgment, to wit:

UNIT 22, HERONMERE, A CONDOMINIUM ACCORDING TO THE DECLARATION OF CONDOMINIUM RECORDED IN OFFICIAL RECORDS BOOK 1298, PAGE 1223, AND AMENDMENTS THERETO, AND AS PER PLAT THEREOF, RECORDED IN CONDOMINIUM BOOK 13, PAGE 2, AND AMENDMENTS THERETO OF THE PUBLIC RECORDS OF SARASOTA COUNTY, FLORIDA. a/k/a 5030 MARSH FIELD ROAD 22, SARASOTA, FL 34235

If you are a person with a disability who needs any accommodation in order to participate in this proceeding, you are entitled, at no cost to you, to the provision of certain assistance. Please contact the Sarasota County Jury Office, P.O. Box 3079, Sarasota, Florida 34230-3079, (941)861-7400, at least seven (7) days before your scheduled court appearance, or immediately upon receiving this notification if the time before the scheduled appearance is less than seven (7) days; if you are hearing or voice impaired, call 711.

By: Eric T. Magoon, Esquire
Florida Bar No.: 562300

Heller & Zion, L.L.P.
Attorneys for Plaintiff
1428 Brickell Avenue,
Suite 700
Miami, FL 33131
Telephone: (305) 373-8001
Facsimile: (305) 373-8030
Designated email address:
mail@hellerzion.com
12074.172
December 13, 20, 2013 13-05796S

SECOND INSERTION

NOTICE OF SALE IN THE CIRCUIT COURT OF THE TWELFTH JUDICIAL CIRCUIT IN AND FOR SARASOTA COUNTY, FLORIDA
CIVIL DIVISION
CASE #: 2011-CA-007617-NC
DIVISION: C

Bank of America, National Association
Plaintiff, vs.-
Krassimira G. Rozanova a/k/a Krassimira Rozanov, Surviving Spouse of Nikolay L. Rozanov a/k/a Nikolay Rozanov, a/k/a Nikolay L. Krassimira, Deceased; Bank of America, National Association; Georgetowne Subdivision Home Owners Association, Inc. d/b/a Georgetowne Estates Home Owners Association, Inc.; Unknown Tenants in Possession #1; Unknown Tenants in Possession #2; If living, and all Unknown Parties claiming by, through, under and against the above named Defendant(s) who are not known to be dead or alive, whether said Unknown Parties may claim an interest as Spouse, Heirs, Devisees, Grantees, or Other Claimants.
Defendant(s).

NOTICE IS HEREBY GIVEN pursuant to an Order dated October 31, 2013, entered in Civil Case No. 2011-CA-007617-NC of the Circuit Court of the 12th Judicial Circuit in and for Sarasota County, Florida, wherein Bank of America, National Association, Plaintiff and Krassimira G. Rozanova a/k/a Krassimira Rozanov, Surviving Spouse of Nikolay L. Rozanov a/k/a Nikolay Rozanov, a/k/a Nikolay L. Krassimira, Deceased are defendant(s), I, Clerk of Court, Karen E. Rushing, will sell to the highest and best bid-

der for cash VIA THE INTERNET AT WWW.SARASOTA.REALFORECLOSE.COM, AT 9:00 A.M. on December 30, 2013, the following described property as set forth in said Final Judgment, to-wit:

LOT 10, BLOCK E, GEORGETOWNE SUBDIVISION, UNIT II, ACCORDING TO THE PLAT THEREOF, RECORDED IN PLAT BOOK 27, PAGES 5 AND 5A THROUGH 5D, PUBLIC RECORDS OF SARASOTA COUNTY, FLORIDA.

ANY PERSON CLAIMING AN INTEREST IN THE SURPLUS FROM THE SALE, IF ANY, OTHER THAN THE PROPERTY OWNER AS OF THE DATE OF THE LIS PENDENS MUST FILE A CLAIM WITHIN 60 DAYS AFTER THE SALE.

If you are a person with a disability who needs any accommodation in order to participate in this proceeding, you are entitled, at no cost to you, to the provision of certain assistance. Please contact the Sarasota County Jury Office, P.O. Box 3079, Sarasota, Florida 34230-3079, (941)861-7400, at least seven (7) days before your scheduled court appearance, or immediately upon receiving this notification if the time before the scheduled appearance is less than seven (7) days; if you are hearing or voice impaired, call 711.

Submitted By:
ATTORNEY FOR PLAINTIFF:
SHAPIRO, FISHMAN & GACHÉ, LLP
2424 North Federal Highway,
Suite 360
Boca Raton, Florida 33431
(561) 998-6700
(561) 998-6707
10-208946 FC01 CWF
December 13, 20, 2013 13-05825S

SECOND INSERTION

NOTICE OF SALE IN THE CIRCUIT COURT OF THE TWELFTH JUDICIAL CIRCUIT IN AND FOR SARASOTA COUNTY, FLORIDA
CIVIL DIVISION
CASE #: 2009-CA-020834-NC
DIVISION: A

Wells Fargo Bank, N.A., as Trustee for Wamu Mortgage Pass-Through Certificates Series 2005-PR1 Trust
Plaintiff, vs.-
Wilson Barrera; American Express Centurion Bank; Unknown Parties in Possession #1 as to Unit A; If living, and all Unknown Parties claiming by, through, under and against the above named Defendant(s) who are not known to be dead or alive, whether said Unknown Parties may claim an interest as Spouse, Heirs, Devisees, Grantees, or Other Claimants
Defendant(s).

NOTICE IS HEREBY GIVEN pursuant to an Order dated November 20, 2013, entered in Civil Case No. 2009-CA-020834-NC of the Circuit Court of the 12th Judicial Circuit in and for Sarasota County, Florida, wherein Wells Fargo Bank, N.A., as Trustee for Wamu Mortgage Pass-Through Certificates Series 2005-PR1 Trust, Plaintiff and Wilson Barrera are defendant(s), I, Clerk of Court, Karen E. Rushing, will sell to the highest and best bidder for cash VIA THE INTERNET AT WWW.SARASOTA.REALFORECLOSE.COM, AT 9:00 A.M. on December 30, 2013, the following described property as set forth in said Final Judgment, to-wit:

LOT 7, OF THE SUBDIVISION OF LOT 19, BLOCK

G, OF THE ORIGINAL PLAT OF THE TOWN OF SARASOTA, ACCORDING TO THE PLAT THEREOF, AS RECORDED IN PLAT BOOK 1, PAGE 166, OF THE PUBLIC RECORDS OF MANATEE COUNTY, FLORIDA, AND PLAT BOOK A, PAGE 57, OF THE PUBLIC RECORDS OF SARASOTA COUNTY, FLORIDA.

ANY PERSON CLAIMING AN INTEREST IN THE SURPLUS FROM THE SALE, IF ANY, OTHER THAN THE PROPERTY OWNER AS OF THE DATE OF THE LIS PENDENS MUST FILE A CLAIM WITHIN 60 DAYS AFTER THE SALE.

If you are a person with a disability who needs any accommodation in order to participate in this proceeding, you are entitled, at no cost to you, to the provision of certain assistance. Please contact the Sarasota County Jury Office, P.O. Box 3079, Sarasota, Florida 34230-3079, (941)861-7400, at least seven (7) days before your scheduled court appearance, or immediately upon receiving this notification if the time before the scheduled appearance is less than seven (7) days; if you are hearing or voice impaired, call 711.

Submitted By:
ATTORNEY FOR PLAINTIFF:
SHAPIRO, FISHMAN & GACHÉ, LLP
2424 North Federal Highway,
Suite 360
Boca Raton, Florida 33431
(561) 998-6700
(561) 998-6707
09-160407 FC01 W50
December 13, 20, 2013 13-05827S

SECOND INSERTION

NOTICE OF FORECLOSURE SALE IN THE CIRCUIT COURT OF THE TWELFTH JUDICIAL CIRCUIT, IN AND FOR SARASOTA COUNTY, FLORIDA

Case No. 2010 CA 001389 NC
OCWEN LOAN SERVICING, LLC
Plaintiff vs.
SLAWOMIR SZYMACHA; ET AL
Defendants

NOTICE IS HEREBY GIVEN that, in accordance with the Final Judgment of Foreclosure dated November 18th, 2013, and entered in Case No. 2013 CA 001389 NC, of the Circuit Court of the Twelfth Judicial Circuit in and for Sarasota County, Florida. Ocwen Loan Servicing, LLC, Plaintiff and SLAWOMIR SZYMACHA; ET AL, are defendants. The Clerk of the Court will sell to the highest and best bidder for cash on www.sarasota.realforeclose.com, SALE BEGINNING AT 9:00 AM ON THE PRESCRIBED DATE this December 26th, 2013, the following described property as set forth in said Final Judgment, to wit:

LOT 35, BLOCK 914, 20TH ADDITION TO PORT CHARLOTTE SUBDIVISION, ACCORDING TO THE PLAT THEREOF AS RECORDED IN PLAT BOOK 14, PAGE(S) 8, 8A THROUGH 8G, INCLUSIVE, OF THE PUBLIC RECORDS OF SARASOTA COUNTY, FLORIDA.

Property Address: 2273 Baltimore St, North Port, FL 34286
A person claiming an interest in the surplus from the sale, if any, other than the property owner as of the date of the lis pendens must file a claim within 60 days after the sale.

This notice is provided pursuant to Administrative Order No.2.065.

If you are a person with a disability who needs any accommodation in order to participate in this proceeding, you are entitled, at no cost to you, to the provision of certain assistance. Please contact the Sarasota County Jury Office, P.O. Box 3079, Sarasota, Florida 34230-3079, (941)861-7400, at least seven (7) days before your scheduled court appearance, or immediately upon receiving this notification if the time before the scheduled appearance is less than seven (7) days; if you are hearing or voice impaired, call 711.

Dated this 4 day of December, 2013.
By: Mark Olivera, Esquire
F. Bar #22817
FLEService@udren.com
UDREN LAW OFFICES, P.C.
2101 West Commercial Blvd., Suite 5000
Fort Lauderdale, FL 33309
Telephone 954-378-1757
Fax 954-378-1758
MJU #12100300-1
December 13, 20, 2013 13-05802S

SECOND INSERTION

NOTICE OF FORECLOSURE SALE IN THE CIRCUIT COURT OF THE TWELFTH JUDICIAL CIRCUIT IN AND FOR SARASOTA COUNTY, FLORIDA

CIVIL ACTION
CASE NO.: 58-2012-CA-004847 NC
DIVISION: C
JPMORGAN CHASE BANK, N.A.,
Plaintiff, vs.
MARGARET D. KRUGER, et al,
Defendant(s).

NOTICE IS HEREBY GIVEN pursuant to a Final Judgment of Mortgage Foreclosure dated December 2, 2013 and entered in Case No. 58-2012-CA-004847 NC of the Circuit Court of the TWELFTH Judicial Circuit in and for SARASOTA County, Florida wherein JPMORGAN CHASE BANK, N.A. is the Plaintiff and MARGARET D KRUGER; LAWRENCE O'CONNOR; BRANCH BANKING AND TRUST COMPANY; THE VENICE GOLF & COUNTRY CLUB MASTER ASSOCIATION, INC.; VENICE GOLF AND COUNTRY CLUB #1, INC.; are the Defendants. The Clerk will sell to the highest and best bidder for cash at WWW.SARASOTA.REALFORECLOSE.COM at 9:00AM, on the 6th day of January, 2014, the following described property as set forth in said Final Judgment:

LOT 215, VENICE GOLF AND COUNTRY CLUB, UNIT NO. II-D, ACCORDING TO THE PLAT THEREOF, RECORDED IN PLAT BOOK 35, PAGE 5, OF THE PUBLIC RECORDS OF SARASOTA COUNTY, FLORIDA.

A/K/A 504 SUMMERFIELD WAY, VENICE, FL 34292

Any person claiming an interest in the surplus from the sale, if any, other than the property owner as of the date of the Lis Pendens must file a claim within sixty (60) days after the sale.

If you are a person with a disability who needs any accommodation in order to participate in this proceeding, you are entitled, at no cost to you, to the provision of certain assistance. Please contact the Sarasota County Jury Office, P.O. Box 3079, Sarasota, Florida 34230-3079, (941)861-7400, at least seven (7) days before your scheduled court appearance, or immediately upon receiving this notification if the time before the scheduled appearance is less than seven (7) days; if you are hearing or voice impaired, call 711.

By: Salina B. Klinghammer
Florida Bar No. #6041
Ronald R Wolfe & Associates, P.L.
P.O. Box 25018
Tampa, Florida 33622-5018
(813) 251-4766
(813) 251-1541 Fax
FI0080587
December 13, 20, 2013 13-05830S

SECOND INSERTION

NOTICE OF FORECLOSURE SALE IN THE CIRCUIT COURT OF THE TWELFTH JUDICIAL CIRCUIT, IN AND FOR SARASOTA COUNTY, FLORIDA

CASE NO. 2009 CA 019133 NC
GTE FEDERAL CREDIT UNION,
Plaintiff, vs.
KIM P. MANNING AND JOHN D. MANNING,
Defendants.

Notice is hereby given that the Clerk of Circuit Court, Sarasota County, Florida, will on the 9th day of January, 2014, at 9:00 a.m., via the Internet at www.sarasota.realforeclose.com, offer for sale and sell at public outcry, one by one, to the highest bidder for cash, the property located in Sarasota County, Florida, as follows:

LOT 3, BLOCK 19, BIRD KEY, AS PER PLAT THEREOF RECORDED IN PLAT BOOK 11, PAGES 20 AND 20A THRU 20F, OF THE PUBLIC RECORDS OF SARASOTA COUNTY, FLORIDA.

pursuant to the Final Judgment of Foreclosure entered on December 4, 2013 in the above-styled cause, pending in said Court.

Any person claiming an interest in the surplus from the sale, if any, other than the property owner as of the date of the lis pendens must file a claim within 60 days after the sale.

If you are a person with a disability who needs any accommodation in order to participate in this proceeding, you are entitled, at no cost to you, to the provision of certain assistance. Please contact the Sarasota County Jury Office, P.O. Box 3079, Sarasota, Florida 34230-3079, (941)861-7400, at least seven (7) days before your scheduled court appearance, or immediately upon receiving this notification if the time before the scheduled appearance is less than seven (7) days; if you are hearing or voice impaired, call 711.

/s/ James E. Sorenson
JAMES E. SORENSON
(FL Bar #0086525),
D. TYLER VAN LEUVEN
(FL Bar #0178705),
JACK E. KIKER, III
(FL Bar #0010207),
F. PALMER WILLIAMS
(FL Bar #0153148), &
J. BLAIR BOYD
(FL Bar #28840), of

Williams, Gautier, Gwynn,
Deloach & Sorenson, P.A.
Post Office Box 4128
Tallahassee, FL 32315-4128
Telephone: (850) 386-3300/
Facsimile: (850) 205-4755
creservice@wggdlaw.com
(E-Service E-Mail Address)
Attorneys for Plaintiff
December 13, 20, 2013 13-05828S

SECOND INSERTION

NOTICE OF RESCHEDULED SALE IN THE CIRCUIT COURT OF THE TWELFTH JUDICIAL CIRCUIT IN AND FOR SARASOTA COUNTY, FLORIDA

CIVIL ACTION
CASE NO.: 2008 CA 019074 NC
DIVISION: A
WACHOVIA MORTGAGE, FSB,
F.K.A. WORLD SAVINGS BANK,
Plaintiff, vs.
EVA SYNEK-STAHN, et al,
Defendant(s).

NOTICE IS HEREBY GIVEN Pursuant to an Order Rescheduling Foreclosure Sale dated November 26, 2013, and entered in Case No. 2008 CA 019074 NC of the Circuit Court of the Twelfth Judicial Circuit in and for Sarasota County, Florida in which Wachovia Mortgage, FSB, f.k.a. World Savings Bank, is the Plaintiff and Juergen Stahl, Eva Synek-Stahl, are defendants, the Sarasota County Clerk of the Circuit Court will sell to the highest and best bidder for cash in/on the Internet: www.sarasota.realforeclose.com, Sarasota County, Florida at 9:00am on the 10th day of January, 2014, the following described property as set forth in said Final Judgment of Foreclosure:

LOT 18, SARA SANDS UNIT NO. 1, ACCORDING TO THE PLAT THEREOF RECORDED IN PLAT BOOK 7, PAGE 56, OF THE PUBLIC RECORDS OF SARASOTA COUNTY, FLORIDA

A/K/A 5059 WINDWARD AVE, SARASOTA, FL 34242

Any person claiming an interest in the surplus from the sale, if any, other than the property owner as of the date of the Lis Pendens must file a claim within 60 days after the sale.

If you are a person with a disability who needs any accommodation in order to participate in this proceeding, you are entitled, at no cost to you, to the provision of certain assistance. Please contact the Sarasota County Jury Office, P.O. Box 3079, Sarasota, Florida 34230-3079, (941)861-7400, at least seven (7) days before your scheduled court appearance, or immediately upon receiving this notification if the time before the scheduled appearance is less than seven (7) days; if you are hearing or voice impaired, call 711.

Dated: December 9, 2013
By: /s/ Heather J. Koch
Phelan Hallinan, PLC
Heather J. Koch, Esq.,
Florida Bar No. 89107
Emilio R. Lenzi, Esq.,
Florida Bar No. 0668273
Phelan Hallinan, PLC
Attorneys for Plaintiff
2727 West Cypress Creek Road
Ft. Lauderdale, FL 33309
Tel: 954-462-7000
Fax: 954-462-7001
Service by email:
FL.Service@PhelanHallinan.com
December 13, 20, 2013 13-05843S

SECOND INSERTION

NOTICE OF FORECLOSURE SALE IN THE CIRCUIT COURT OF THE TWELFTH JUDICIAL CIRCUIT, IN AND FOR SARASOTA COUNTY, FLORIDA

CIVIL DIVISION
CASE NO.: 2012 CA 005064 NC
JPMORGAN CHASE BANK,
NATIONAL ASSOCIATION
Plaintiff, vs.
TERESA A. WILSON, et al
Defendants.

NOTICE IS HEREBY GIVEN pursuant to a Summary Final Judgment of foreclosure dated September 24, 2013, and entered in Case No. 2012 CA 005064 NC of the Circuit Court of the TWELFTH Judicial Circuit in and for SARASOTA COUNTY, Florida, wherein JPMORGAN CHASE BANK, NATIONAL ASSOCIATION, is Plaintiff, and TERESA A. WILSON, et al are Defendants, the clerk will sell to the highest and best bidder for cash, beginning at 09:00 AM at www.sarasota.realforeclose.com, in accordance with Chapter 45, Florida Statutes, on the 07 day of January, 2014, the following described property as set forth in said Summary Final Judgment, to wit:

Lot 884, KENSINGTON PARK, UNIT 7, according to the plat thereof, recorded in Plat Book 16, Page 16, of the Public Records of SARASOTA County, Florida.

Any person claiming an interest in the surplus funds from the sale, if any, other than the property owner as of the date of the lis pendens must file a claim within 60 days after the sale.

If you are a person with a disability who needs any accommodation in order to participate in this proceeding, you are entitled, at no cost to you, to the provision of certain assistance. Please contact the Sarasota County Jury Office, P.O. Box 3079, Sarasota, Florida 34230-3079, (941)861-7400, at least seven (7) days before your scheduled court appearance, or immediately upon receiving this notification if the time before the scheduled appearance is less than seven (7) days; if you are hearing or voice impaired, call 711.

Dated: December 9, 2013
By: /s/ Heather J. Koch
Phelan Hallinan, PLC
Heather J. Koch, Esq.,
Florida Bar No. 89107
Emilio R. Lenzi, Esq.,
Florida Bar No. 0668273
Phelan Hallinan, PLC
Attorneys for Plaintiff
2727 West Cypress Creek Road
Ft. Lauderdale, FL 33309
Tel: 954-462-7000
Fax: 954-462-7001
Service by email:
FL.Service@PhelanHallinan.com
December 13, 20, 2013 13-05846S

SECOND INSERTION

NOTICE OF FORECLOSURE SALE IN THE CIRCUIT COURT OF THE TWELFTH JUDICIAL CIRCUIT, IN AND FOR SARASOTA COUNTY, FLORIDA

CASE NO. 2011 CA 007482 NC
BRANCH BANKING AND TRUST COMPANY,
Plaintiff, vs.
EDWARD C. KELLY; KASSANDRA A. WILLIAMS, et al.
Defendants

NOTICE IS HEREBY GIVEN pursuant to a Final Judgment of Foreclosure dated November 18, 2013, and entered in Case No. 2011 CA 007482 NC, of the Circuit Court of the Twelfth Judicial Circuit in and for SARASOTA County, Florida. BRANCH BANKING AND TRUST COMPANY, is Plaintiff and EDWARD C. KELLY; KASSANDRA A. WILLIAMS; THE VILLAGES AT PINE TREE HOA, INC., are defendants. The Clerk of Court will sell to the highest and best bidder for cash via the Internet at www.sarasota.realforeclose.com, at 9:00 a.m., on the 18th day of March, 2014, the following described property as set forth in said Final Judgment, to wit:

LOT 3000, VILLAGES AT PINETREE, MARSH PINE ENCLAVE, A SUBDIVISION AS PER PLAT THEREOF RECORDED IN PLAT BOOK 45, PAGE 22, OF THE PUBLIC RECORDS OF SARASOTA COUNTY, FLORIDA

Any person claiming an interest in the surplus from the sale, if any, other than the property owner as of the date of the Lis Pendens must file a claim within 60 days after the sale.

If you are a person with a disability who needs any accommodation in order to participate in this proceeding, you are entitled, at no cost to you, to the provision of certain assistance. Please contact the Sarasota County Jury Office, P.O. Box 3079, Sarasota, Florida 34230-3079, (941)861-7400, at least seven (7) days before your scheduled court appearance, or immediately upon receiving this notification if the time before the scheduled appearance is less than seven (7) days; if you are hearing or voice impaired, call 711.

Mark C. Elia, Esq.,
Florida Bar #: 695734
Email: MCElia@vanlawfl.com
VAN NESS LAW FIRM, PLC
1239 E. Newport Center Drive, Suite 110
Deerfield Beach, Florida 33442
Ph: (954) 571-2031
Fax: (954) 571-2033
PRIMARY EMAIL:
Pleadings@vanlawfl.com
BB1255-13/ee
December 13, 20, 2013 13-05848S

SECOND INSERTION

NOTICE OF SALE IN THE CIRCUIT COURT IN AND FOR THE TWELFTH JUDICIAL CIRCUIT SARASOTA COUNTY, FLORIDA

CIVIL DIVISION
CASE NO: 2011 CA 006098 NC
Division "A"

BRANCH BANKING AND TRUST COMPANY, a North Carolina banking corporation,
Plaintiff, vs.

KHLEIF AND KHLEIF, LTD., a Colorado limited partnership, ROD A. KHLEIF, FLORIDA FIRST ESCROW COMPANY, a Florida corporation, in its individual corporate capacity, and as TRUSTEE for the 1531 Mongoose Giving Trust dated January 1, 2002, MELIN KHLEIF, SOUTH BRIDGE PARK CONDOMINIUM ASSOCIATION, INC., No. 4, a Florida not for profit corporation, and the CITY OF SARASOTA, FLORIDA,
Defendants.

Notice is hereby given that pursuant to the Final Summary Judgment of Foreclosure entered in the above-styled Case No. 2011-CA-6098-NC, on October 22, 2013 in the above styled cause, in the Circuit Court of Sarasota County, Florida, the office of Karen E. Rushing, Clerk of the above-titled court, will sell the property situate in Sarasota County, Florida, described as:

Units 8A -through 8T, South Bridge Park No. 4, a Condominium, per Declaration of Condominium recorded in Official Records Book 2009, Pages 410 through 480, inclusive, amended in Official Records Book 2125, Page 2915, and as per plat thereof recorded in Condominium Book 27, Page 3, 3A and 3B, amended in Condominium Book 28, Pages 4, 4A and 4B, inclusive, of the Public Records of Sarasota County, Florida.

PIN 0433-03-1309 (Units 8A through 8J and Units 8O through 8T)
PIN 0433-03-1306 (Units 8K, 8L, 8M and 8N)
C/K/A 1531 S. Tamiami Trail, Venice, Florida

at public sale, to the highest and best bidder, for cash, at www.sarasota.realforeclose.com at 9:00 A.M., on January 13, 2014. The highest bidder shall immediately post with the Clerk, a deposit equal to 5% of the final bid. The deposit must be cash or cashier's check payable to the Clerk of Court and will be applied to the sale price at the time of final payment. Final payment must be made on or before 5:00 p.m. of the day of the sale by cash or cashier's check.

Any person claiming an interest in the surplus from the sale, if any, other than the property owner as of the date of the lis pendens, must file a claim within 60 days after the sale.

If you are a person with a disability who needs any accommodation in order to participate in this proceeding, you are entitled, at no cost to you, to the provision of certain assistance. Please contact the Sarasota County Jury Office, P.O. Box 3079, Sarasota, Florida 34230-3079, (941)861-7400, at least seven (7) days before your scheduled court appearance, or immediately upon receiving this notification if the time before the scheduled appearance is less than seven (7) days; if you are hearing or voice impaired, call 711.

Dated this 10th day of December, 2013.
By: JAVIER A. PACHECO, ESQUIRE
Florida Bar No. 51368
Javier A. Pacheco, Esq.,
Porter, Wright Morris & Arthur, LLP
9132 Strada Place, Third Floor
Naples, FL 34108
Phone: 239-593-2900
Attorneys for Plaintiff
jpacheco@porterwright.com
December 13, 20, 2013 13-05852S

SECOND INSERTION

NOTICE OF RESCHEDULED FORECLOSURE SALE IN THE CIRCUIT COURT OF THE TWELFTH JUDICIAL CIRCUIT IN AND FOR SARASOTA COUNTY, FLORIDA

CIVIL ACTION
CASE NO.: 2009-CA-018529-NC
DIVISION: A
WELLS FARGO BANK, N.A., AS TRUSTEE FOR THE HOLDERS OF BANC OF AMERICA ALTERNATIVE LOAN TRUST 2006-6 MORTGAGE PASS-THROUGH CERTIFICATES SERIES 2006-6,
Plaintiff, vs.
SARA FLETES, et al,
Defendant(s).

NOTICE IS HEREBY GIVEN pursuant to an Order Rescheduling Foreclosure Sale dated December 2, 2013 and entered in Case No. 2009-CA-018529-NC of the Circuit Court of the TWELFTH Judicial Circuit in and for SARASOTA County, Florida wherein WELLS FARGO BANK, N.A., AS TRUSTEE FOR THE HOLDERS OF BANC OF AMERICA ALTERNATIVE LOAN TRUST 2006-6 MORTGAGE PASS-THROUGH CERTIFICATES SERIES 2006-6, is the Plaintiff and SARA FLETES; THE UNKNOWN SPOUSE OF SARA FLETES N/K/A CARLO BETANCOURT; TENANT #1 N/K/A JENNET RODRIGUEZ are the Defendants. The Clerk will sell to the highest and best bidder for cash at WWW.SARASOTA.REALFORECLOSE.COM at 9:00AM, on 01/06/2014, the following described property as set forth in said Final Judgment:

THE SOUTH 120.2 FEET OF LOT 19, BLOCK B, LENRAY HEIGHTS, ACCORDING TO THE PLAT THEREOF, AS RECORDED IN PLAT BOOK 1, PAGE 43 AND 44 OF THE PUBLIC RECORDS OF SARASOTA COUNTY, FLORIDA. AND ALSO AN EASEMENT IN COMMON WITH OTHER OWNERS ABUT-

TING THEREON, OVER AND ACROSS THE FOLLOWING DESCRIBED STRIP OF LAND, TO WIT: BEGIN AT A POINT 25 FEET SOUTH OF THE NORTHEAST CORNER OF LOT 26, BLOCK B, LENRAY HEIGHTS; THENCE WEST TO A POINT 25 FEET SOUTH OF THE NORTHWEST CORNER OF LOT 14, BLOCK B, LENRAY HEIGHTS; THENCE NORTH 50 FEET; THENCE EAST TO A POINT 25 FEET NORTH OF THE SOUTHEAST CORNER OF LOT 13, BLOCK B, LENRAY HEIGHTS, THENCE SOUTH 50 FEET TO THE POINT OF BEGINNING.

A/K/A 2622 19TH STREET, SARASOTA, FL 34234

Any person claiming an interest in the surplus from the sale, if any, other than the property owner as of the date of the Lis Pendens must file a claim within sixty (60) days after the sale.

If you are a person with a disability who needs any accommodation in order to participate in this proceeding, you are entitled, at no cost to you, to the provision of certain assistance. Please contact the Sarasota County Jury Office, P.O. Box 3079, Sarasota, Florida 34230-3079, (941)861-7400, at least seven (7) days before your scheduled court appearance, or immediately upon receiving this notification if the time before the scheduled appearance is less than seven (7) days; if you are hearing or voice impaired, call 711.

By: Kimberly L. Garno
Florida Bar No. 84538
Ronald R Wolfe & Associates, P.L.
P.O. Box 25018
Tampa, Florida 33622-5018
(813) 251-4766
(813) 251-1541 Fax
F09105701
December 13, 20, 2013 13-05870S

SECOND INSERTION

NOTICE OF SALE PURSUANT TO CHAPTER 45 IN THE TWELFTH JUDICIAL CIRCUIT IN AND FOR SARASOTA COUNTY, FLORIDA CIRCUIT CIVIL

CASE NO.: 2009-CA-21928-NC
HSBC BANK USA, N.A., AS INDENTURE TRUSTEE FOR THE REGISTERED

NOTEHOLDERS OF RENAISSANCE HOME EQUITY LOAN ASSET-BACKED NOTES, SERIES 2005-2,
Plaintiff, vs.

LAWRENCE LUNCAN, A SINGLE MAN; CITIBANK NATIONAL ASSOCIATION, AS SUCCESSOR BY MERGER TO CITIBANK, FEDERAL SAVINGS BANK; UNKNOWN OCCUPANT "A" N/K/A RANDY LANGE RESIDING AT 2063 S CRANBERRY BLVD, NORTH PORT, FL 34286 AND UNKNOWN OCCUPANT "B" N/K/A STEPHANIE LUNCAN RESIDING AT 2063 S CRANBERRY BLVD, NORTH PORT, FL 34286,
Defendant(s).

NOTICE IS HEREBY GIVEN pursuant to an Order or Final Judgment of Foreclosure signed December 3, 2013, and entered in Case No. 2009-CA-21928-NC of the Circuit Court of the TWELFTH Judicial Circuit in and for SARASOTA County, Florida, wherein HSBC BANK USA, N.A., AS INDENTURE TRUSTEE FOR THE REGISTERED NOTEHOLDERS OF RENAISSANCE HOME EQUITY LOAN ASSET-BACKED NOTES, SERIES 2005-2 is the Plaintiff and LAWRENCE LUNCAN, A SINGLE MAN; CITIBANK NATIONAL ASSOCIATION, AS SUCCESSOR BY MERGER TO CITIBANK, FEDERAL SAVINGS BANK; UNKNOWN OCCUPANT "A" N/K/A RANDY LANGE RESIDING AT 2063 S CRANBERRY BLVD, NORTH PORT, FL 34286 AND UNKNOWN OCCUPANT "B" N/K/A STEPHANIE LUNCAN RESIDING AT 2063

S CRANBERRY BLVD, NORTH PORT, FL 34286, are the Defendants, the Clerk shall offer for sale to the highest and best bidder for cash All Judicial Foreclosure Sales are held online via the Internet at www.sarasota.realforeclose.com pursuant to Florida Statute 45.031(10), at 9:00 AM EST on the 10th day of January, 2014, the following described property as set forth in said Order of Final Judgment, to wit: LOT 21 BLOCK 425 9TH ADDITION TO PORT CHARLOTTE SUB. A SUBDIVISION ACCORDING TO THE PLAT THEREOF AS RECORDED IN PLAT BOOK 12 PAGE 21, 21A-21S OF THE PUBLIC RECORDS OF SARASOTA COUNTY FLORIDA.

Any person claiming an interest in the surplus from the sale, if any, other than the property owner as of the date of the Lis Pendens must file a claim within 60 days after the sale.

If you are a person with a disability who needs any accommodation in order to participate in this proceeding, you are entitled, at no cost to you, to the provision of certain assistance. Please contact the Sarasota County Jury Office, P.O. Box 3079, Sarasota, Florida 34230-3079, (941)861-7400, at least seven (7) days before your scheduled court appearance, or immediately upon receiving this notification if the time before the scheduled appearance is less than seven (7) days; if you are hearing or voice impaired, call 711.

BY: /s/ Kent D. McPhail
Kent D. McPhail, Esq.,
Fla. Bar # 852767
Primary E-Mail: flservice@dumasmcphail.com
DUMAS & MCPHAIL, L.L.C.
Attorney for Plaintiff
126 Government Street (36602)
Post Office Box 870
Mobile, AL 36601
(251) 438-2333
FL-09-1766
December 13, 20, 2013 13-05844S

SECOND INSERTION

NOTICE OF SALE
IN THE CIRCUIT COURT OF THE
TWELFTH JUDICIAL CIRCUIT
IN AND FOR SARASOTA COUNTY,
FLORIDA,
CIVIL ACTION
CASE NO.: 2012 CA 003030 NC
BANK OF AMERICA, N.A.,
Plaintiff vs.
ALBERT CAMPBELL, et al.
Defendant(s)

Notice is hereby given that, pursuant to an Order Rescheduling Foreclosure Sale, dated November 1st, 2013, entered in Civil Case Number 2012 CA 003030 NC, in the Circuit Court for Sarasota County, Florida, wherein BANK OF AMERICA, N.A. is the Plaintiff, and ALBERT CAMPBELL, et al., are the Defendants, Sarasota County Clerk of Court will sell the property situated in Sarasota County, Florida, described as:

LOT 20 AND THE SOUTH ONE-HALF OF LOT 21, BLOCK C, BAY VIEW MANOR SUBDIVISION, ACCORDING TO THE PLAT THEREOF AS RECORDED IN PLAT BOOK 2, PAGES 13 AND 13A, INCLUSIVE, OF THE PUBLIC RECORDS OF SARASOTA COUNTY, FLORIDA.

at public sale, to the highest and best bidder, for cash, at www.sarasota.realforeclose.com at 09:00 AM, on the 4th day of March, 2014. Any person claiming an interest in the surplus from the sale, if any, other than the property owner as of the date of the lis pendens must file a claim within 60 days after the sale.

If you are a person with a disability who needs any accommodation in order to participate in this proceeding, you are entitled, at no cost to you, to the provision of certain assistance. Please contact the Sarasota County Jury Office, P.O. Box 3079, Sarasota, Florida 34230-3079, (941)861-7400, at least seven (7) days before your scheduled court appearance, or immediately upon receiving this notification if the time before the scheduled appearance is less than seven (7) days; if you are hearing or voice impaired, call 711.

Dated: December 9, 2013
By: /s/ Erik T. Silevitch
Erik T. Silevitch, Esquire
(FBN 92048)

FLORIDA FORECLOSURE ATTORNEYS, PLLC
4855 Technology Way,
Suite 500
Boca Raton, FL 33431
(727) 446-4826
emailservice@ffapllc.com
Our File No: CA11-06641/OA
December 13, 20, 2013 13-05836S

SECOND INSERTION

NOTICE OF FORECLOSURE SALE
IN THE CIRCUIT COURT OF THE
TWELFTH JUDICIAL CIRCUIT
IN AND FOR SARASOTA COUNTY,
FLORIDA,
CIVIL ACTION
CASE NO.: 2011-CA-002718-NC
DIVISION: A

WELLS FARGO BANK, NA,
Plaintiff, vs.
CHARLES V. BAKER, et al,
Defendant(s).
NOTICE IS HEREBY GIVEN pursuant to a Final Judgment of Mortgage Foreclosure dated December 4, 2013 and entered in Case No. 2011-CA-002718-NC of the Circuit Court of the Twelfth Judicial Circuit in and for Sarasota County, Florida wherein WELLS FARGO BANK, NA is the Plaintiff and CHARLES V BAKER; DORIS J BAKER; TENANT #1 N/K/A JEFFREY BAKER are the Defendants, The Clerk will sell to the highest and best bidder for cash at WWW.SARASOTA.REALFORECLOSE.COM at 9:00AM, on the 9th day of January, 2014, the following described property as set forth in said Final Judgment:

LOTS 1374, 1375, AND 1376, OF UNIT NO. 5, SOUTH VENICE, ACCORDING TO THE PLAT THEREOF, AS RECORDED IN PLAT BOOK 6, AT PAGE 33, OF THE PUBLIC RECORDS OF SARASOTA COUNTY, FLORIDA

A/K/A 863 FLAMINGO ROAD, VENICE, FL 34293
Any person claiming an interest in the surplus from the sale, if any, other than the property owner as of the date of the Lis Pendens must file a claim within sixty (60) days after the sale.

If you are a person with a disability who needs any accommodation in order to participate in this proceeding, you are entitled, at no cost to you, to the provision of certain assistance. Please contact the Sarasota County Jury Office, P.O. Box 3079, Sarasota, Florida 34230-3079, (941)861-7400, at least seven (7) days before your scheduled court appearance, or immediately upon receiving this notification if the time before the scheduled appearance is less than seven (7) days; if you are hearing or voice impaired, call 711.

By: Victoria S. Jones
Florida Bar No. 52252
Ronald R Wolfe & Associates, P.L.
P.O. Box 25018
Tampa, Florida 33622-5018
(813) 251-4766
(813) 251-1541 Fax
F11008685
December 13, 20, 2013 13-05831S

SECOND INSERTION

NOTICE OF SALE
IN THE CIRCUIT COURT OF THE
TWELFTH JUDICIAL CIRCUIT
IN AND FOR SARASOTA COUNTY,
FLORIDA,
CIVIL DIVISION
CASE #: 2010-CA-004535-NC
DIVISION: C

Bank of America, N.A.
Plaintiff, vs.-
Wayne Taylor; Gina M. Taylor a/k/a Gina Taylor;
Defendant(s).
NOTICE IS HEREBY GIVEN pursuant to an Order dated November 22, 2013, entered in Civil Case No. 2010-CA-004535-NC of the Circuit Court of the 12th Judicial Circuit in and for Sarasota County, Florida, wherein Bank of America, N.A., Plaintiff and Wayne Taylor are defendant(s), I, Clerk of Court, Karen E. Rushing, will sell to the highest and best bidder for cash VIA THE INTERNET AT WWW.SARASOTA.REALFORECLOSE.COM, AT 9:00 A.M. on December 27, 2013, the following described property as set forth in said Final Judgment, to-wit:

LOT 7, BLOCK 1, GOULDS ADDITION TO ENGLEWOOD, AS PER PLAT THEREOF, RECORDED IN PLAT BOOK 4, PAGE 66, OF THE PUBLIC RECORDS OF SARASOTA COUNTY, FLORIDA.

ANY PERSON CLAIMING AN INTEREST IN THE SURPLUS FROM THE SALE, IF ANY, OTHER THAN THE PROPERTY OWNER AS OF THE DATE OF THE LIS PENDENS MUST FILE A CLAIM WITHIN 60 DAYS AFTER THE SALE.

If you are a person with a disability who needs any accommodation in order to participate in this proceeding, you are entitled, at no cost to you, to the provision of certain assistance. Please contact the Sarasota County Jury Office, P.O. Box 3079, Sarasota, Florida 34230-3079, (941)861-7400, at least seven (7) days before your scheduled court appearance, or immediately upon receiving this notification if the time before the scheduled appearance is less than seven (7) days; if you are hearing or voice impaired, call 711.

Submitted By:
ATTORNEY FOR PLAINTIFF:
SHAPIRO, FISHMAN & GACHÉ, LLP
2424 North Federal Highway,
Suite 360
Boca Raton, Florida 33431
(561) 998-6700
(561) 998-6707
10-170619 FC01 CWF
December 13, 20, 2013 13-05826S

SECOND INSERTION

NOTICE OF FORECLOSURE SALE
IN THE CIRCUIT COURT OF THE
TWELFTH JUDICIAL CIRCUIT
IN AND FOR SARASOTA COUNTY,
FLORIDA,
GENERAL JURISDICTION
DIVISION
CASE NO. 2010 CA 010261 NC
RESI WHOLE LOAN III, LLC
Plaintiff, vs.
JOHN H. STAHLER AND
DEBORAH F. STAHLER, et al.
Defendant(s).

NOTICE IS HEREBY GIVEN pursuant to a Final Judgment of Foreclosure dated May 24, 2013, and entered in 2010 CA 010261 NC of the Circuit Court of the Twelfth Judicial Circuit in and for Sarasota County, Florida, wherein RESI WHOLE LOAN III, LLC is the Plaintiff and JOHN H. STAHLER; DEBORAH F. STAHLER; UNKNOWN TENANT(S) are the Defendant(s). Karen Rushing as the Clerk of the Circuit Court will sell to the highest and best bidder for cash, www.sarasota.realforeclose.com, at 09:00 AM on December 30, 2013, the following described property as set forth in said Final Judgment, to wit:

LOT 24, BLOCK 690, OF THE SEVENTEENTH ADDITION TO PORT CHARLOTTE SUBDIVISION ACCORDING TO THE PLAT THEREOF RECORDED IN PLAT BOOK 13, PAGE 16, OF THE PUBLIC RECORDS OF SARASOTA COUNTY, FLORIDA.

Any person claiming an interest in the surplus from the sale, if any, other than the property owner as of the date of the lis pendens must file a claim within 60 days after the sale.

If you are a person with a disability who needs any accommodation in order to participate in this proceeding, you are entitled, at no cost to you, to the provision of certain assistance. Please contact the Sarasota County Jury Office, P.O. Box 3079, Sarasota, Florida 34230-3079, (941)861-7400, at least seven (7) days before your scheduled court appearance, or immediately upon receiving this notification if the time before the scheduled appearance is less than seven (7) days; if you are hearing or voice impaired, call 711.

Dated this 4 day of December, 2013.
By: Nicole A. Ramjattan
Florida Bar: 89204
Robertson, Anschutz & Schneid, PL
Attorneys for Plaintiff
6409 Congress Avenue, Suite 100
Boca Raton, Florida 33487
12-11725
December 13, 20, 2013 13-05800S

SECOND INSERTION

NOTICE OF RESCHEDULED
FORECLOSURE SALE
IN THE CIRCUIT COURT OF THE
TWELFTH JUDICIAL CIRCUIT
IN AND FOR SARASOTA COUNTY,
FLORIDA,
CIVIL ACTION
CASE NO. : 2008 CA 003821 NC
DIVISION: C

BANK OF NEW YORK
AS TRUSTEE FOR THE
CERTIFICATEHOLDERS CWALT,
INC. ALTERNATIVE LOAN
TRUST 2006-0A17 MORTGAGE
PASS-THROUGH CERTIFICATES
SERIES 2006-0A17,
Plaintiff, vs.
CHRISTAL DARBY, et al.
Defendants.
NOTICE IS HEREBY GIVEN that the undersigned Attorney, will on the 31st day of December, 2013, at 9:00AM, EST at www.sarasota.realforeclose.com, offer for sale and sell at public outcry to the highest and best bidder for cash, the following described property situate in SARASOTA, Florida:

LOT 284, AND THE WEST 1/2 OF LOT 283, SARASOTA GOLF CLUB COLONY SUBDIVISION, UNIT NO. 3 ACCORDING TO THE PLAT THEREOF AS RECORDED IN PLAT BOOK 10, PAGE 12, OF THE PUBLIC RECORDS OF SARASOTA COUNTY, FLORIDA.

pursuant to a Final Judgment of Foreclosure entered in Case No. 2008 CA 003821 NC of the Circuit Court of the Twelfth Judicial Circuit in and for SARASOTA County, Florida, the style of which is indicated above.

If you are a person with a disability who needs any accommodation in order to participate in this proceeding, you are entitled, at no cost to you, to the provision of certain assistance. Please contact the Sarasota County Jury Office, P.O. Box 3079, Sarasota, Florida 34230-3079, (941)861-7400, at least seven (7) days before your scheduled court appearance, or immediately upon receiving this notification if the time before the scheduled appearance is less than seven (7) days; if you are hearing or voice impaired, call 711.

By: Jennifer Lane
FLORIDA BAR NO.: 84413
jlane@rcolegal.com
FLCSERVICE@rcolegal.com
RCO Legal, P.S.
1587 Northeast Expressway, M/S 27
Atlanta, Georgia 30329
(770) 234-9181
December 13, 20, 2013 13-05799S

SECOND INSERTION

NOTICE OF SALE
IN THE CIRCUIT COURT OF THE
TWELFTH JUDICIAL CIRCUIT,
IN AND FOR SARASOTA COUNTY,
FLORIDA
CASE NO.: 2008-CA-015515-SC
COUNTRYWIDE HOME LOANS,
INC.,
Plaintiff,
KATHLEEN A. SKULITZ, et al.,
Defendants.

NOTICE IS GIVEN that, in accordance with the Plaintiff's Final Judgment of Foreclosure entered on August 27, 2013 in the above-styled cause, I will sell to the highest and best bidder for cash on December 30, 2013 at 9:00 A.M., at www.sarasota.realforeclose.com the following described property:

Lots 23 & 24, Block 461, 9th ADDITION TO PORT CHARLOTTE SUBDIVISION, according to the plat thereof recorded in Plat Book 12, Page 21, of the Public Records of SARASOTA County, Florida.

Property Address: 2648 Tusket Ave., North Port, FL 34286
ANY PERSON CLAIMING AN INTEREST IN THE SURPLUS FROM THE SALE, IF ANY, OTHER THAN THE PROPERTY OWNER AS OF THE DATE OF THE LIS PENDENS MUST FILE A CLAIM WITHIN 60 DAYS AFTER THE SALE.

If you are a person with a disability who needs any accommodation in order to participate in this proceeding, you are entitled, at no cost to you, to the provision of certain assistance. Please contact the Sarasota County Jury Office, P.O. Box 3079, Sarasota, Florida 34230-3079, (941)861-7400, at least seven (7) days before your scheduled court appearance, or immediately upon receiving this notification if the time before the scheduled appearance is less than seven (7) days; if you are hearing or voice impaired, call 711.

Dated: December 6th, 2013
/s/Brenda Jean
Brenda Jean, Esquire
Florida Bar No.: 89812

Quintairos, Prieto, Wood & Boyer, P.A.
255 S. Orange Ave.,
Ste. 900
Orlando, FL 32801-3454
(407) 872-6011
(407) 872-6012 Facsimile
E-mail: servicecopies@qpwbaw.com
E-mail: bjean@qpwbaw.com
Matter # 59983
December 13, 20, 2013 13-05824S

SECOND INSERTION

RE-NOTICE OF
FORECLOSURE SALE
IN THE CIRCUIT COURT OF THE
TWELFTH JUDICIAL CIRCUIT, IN
AND FOR SARASOTA COUNTY,
FLORIDA
CIVIL DIVISION

CASE NO.: 2009 CA 019549 NC
GMAC MORTGAGE, LLC
Plaintiff, vs.
MARIE B. ROLLO, et al
Defendants.

RE-NOTICE IS HEREBY GIVEN pursuant to an Order Granting Plaintiff's Motion to Reschedule Foreclosure Sale filed November 19, 2014, and entered in Case No. 2009 CA 019549 NC of the Circuit Court of the Twelfth Judicial Circuit in and for SARASOTA COUNTY, Florida, wherein GMAC MORTGAGE, LLC, is Plaintiff, and MARIE B. ROLLO, et al are Defendants, the clerk will sell to the highest and best bidder for cash, beginning at 09:00 AM at www.sarasota.realforeclose.com, in accordance with Chapter 45, Florida Statutes, on the 26 day of December, 2013, the following described property as set forth in said Lis Pendens, to wit:

UNIT No. 33, LUCAYA COUNTRY CLUB VILLAS, formerly known as LUCAYA COUNTRY CLUB VILLAS SECTION 7, a Condominium according to the Declaration of a Condominium recorded in O.R. Book 851, Page 850, and as amended and Certificate of Merger recorded in O.R. Book 2359, Page 894 and as per plat thereof recorded in Condominium Book 3, Pages 15 through

15B, all of the public Records of Sarasota County, Florida. Together with any and all amendments to the declaration and any undivided interest in the common elements or appurtenances thereto.

Any person claiming an interest in the surplus funds from the sale, if any, other than the property owner as of the date of the lis pendens must file a claim within 60 days after the sale.

If you are a person with a disability who needs any accommodation in order to participate in this proceeding, you are entitled, at no cost to you, to the provision of certain assistance. Please contact the Sarasota County Jury Office, P.O. Box 3079, Sarasota, Florida 34230-3079, (941)861-7400, at least seven (7) days before your scheduled court appearance, or immediately upon receiving this notification if the time before the scheduled appearance is less than seven (7) days; if you are hearing or voice impaired, call 711.

Dated: December 10, 2013
By: /s/ Sim J. Singh
Phelan Hallinan, PLC
Sim J. Singh, Esq.,
Florida Bar No. 98122
Emilio R. Lenzi, Esq.,
Florida Bar No. 0668273

Phelan Hallinan, PLC
Attorneys for Plaintiff
2727 West Cypress Creek Road
Ft. Lauderdale, FL 33309
Tel: 954-462-7000
Fax: 954-462-7001
Service by email:
FL.Service@PhelanHallinan.com
PH#38449
December 13, 20, 2013 13-05867S

SECOND INSERTION

NOTICE OF SALE
IN THE CIRCUIT COURT OF THE
TWELFTH JUDICIAL CIRCUIT
IN AND FOR SARASOTA COUNTY,
FLORIDA
CASE NO. 2012 CA 009853 NC
WELLS FARGO BANK, N.A.
Plaintiff, vs.
LLOYD SCHULTZ; UNKNOWN
SPOUSE OF LLOYD SCHULTZ;
UNKNOWN TENANT 1;
UNKNOWN TENANT 2; AND ALL
UNKNOWN PARTIES CLAIMING
BY, THROUGH, UNDER OR
AGAINST THE ABOVE NAMED
DEFENDANT(S), WHO (IS/
ARE) NOT KNOWN TO BE
DEAD OR ALIVE, WHETHER
SAID UNKNOWN PARTIES
CLAIM AS HEIRS, DEVISEES,
GRANTEES, ASSIGNEES,
LIENORS, CREDITORS,
TRUSTEES, SPOUSES, OR OTHER
CLAIMANTS; BRANCH BANKING
AND TRUST COMPANY; ISLES
OF SARASOTA HOMEOWNERS
ASSOCIATION, INC.
Defendants.

Notice is hereby given that, pursuant to the Summary Final Judgment of Foreclosure entered on November 18, 2013, in this cause, in the Circuit Court of Sarasota County, Florida, the clerk shall sell the property situated in Sarasota County, Florida, described as:

LOT 235, ISLES OF SARASOTA, UNIT 1, ACCORDING TO THE MAP OR PLAT THEREOF, AS RECORDED IN PLAT BOOK 45, PAGE(S) 21 THRU 21J, PUBLIC RECORDS OF SARASOTA COUNTY, FLORIDA.

a/k/a 1442 BURGOS DR, SARASOTA, FL 34238-2704
at public sale, to the highest and best bidder, for cash, online at www.sarasota.realforeclose.com, on January 17, 2014 beginning at 09:00 AM.

If you are a person claiming a right to funds remaining after the sale, you must file a claim with the clerk no later than 60 days after the sale. If you fail to file a claim you will not be entitled to any remaining funds.

If you are a person with a disability who needs any accommodation in order to participate in this proceeding, you are entitled, at no cost to you, to the provision of certain assistance. Please contact the Sarasota County Jury Office, P.O. Box 3079, Sarasota, Florida 34230-3079, (941)861-7400, at least seven (7) days before your scheduled court appearance, or immediately upon receiving this notification if the time before the scheduled appearance is less than seven (7) days; if you are hearing or voice impaired, call 711.

Dated at St. Petersburg, Florida, this 3rd day of December, 2013.

By: /s/ Angela L. Leiner, Esquire
Angela L. Leiner
FBN #85112

Douglas C. Zahm, P.A.
Designated Email Address:
efiling@dczahm.com
12425 28th Street North, Suite 200
St. Petersburg, FL 33716
Telephone No. (727) 536-4911
Attorney for the Plaintiff
888122358
December 13, 20, 2013 13-05804S

SECOND INSERTION

NOTICE OF SALE
IN THE CIRCUIT COURT OF THE
TWELFTH JUDICIAL CIRCUIT
IN AND FOR SARASOTA COUNTY,
FLORIDA
CASE NO.: 2009 CA 015864 NC
CITIMORTGAGE, INC.
Plaintiff, vs.
DAVID W. SAULS; JENNIFER
A. SAULS; ANY AND ALL
UNKNOWN PARTIES CLAIMING
BY, THROUGH, UNDER, AND
AGAINST THE HEREIN NAMED
INDIVIDUAL DEFENDANT(S)
WHO ARE NOT KNOWN TO BE
DEAD OR ALIVE, WHETHER
SAID UNKNOWN PARTIES
MAY CLAIM AN INTEREST AS
SPOUSES, HEIRS, DEVISEES,
GRANTEES, OR OTHER
CLAIMANTS; MORTGAGE
ELECTRONIC REGISTRATION
SYSTEMS, INC., AS NOMINEE
FOR 123LOAN, LLC., A NEVADA
LIMITED LIABILITY COMPANY.
Defendant(s).

NOTICE IS HEREBY GIVEN pursuant to an Order of Final Summary Judgment of Foreclosure dated November 18, 2013, entered in Civil Case No. 2009 CA 015864 NC of the Circuit Court of the Twelfth Judicial Circuit in and for Sarasota County, Florida, wherein the Clerk of the Circuit Court will sell to the highest bidder for cash on the 17th day of January, 2014, at 9:00 a.m. online at the website: https://www.sarasota.realforeclose.com, relative to the following described property as set forth in the Final Judgment, to wit:

LOT 17, BLOCK 1707, THIRTY-

SIXTH ADDITION TO PORT CHARLOTTE SUBDIVISION, A SUBDIVISION, ACCORDING TO THE PLAT THEREOF, AS RECORDED IN PLAT BOOK 16, PAGES 3, 3A THROUGH 3M, INCLUSIVE, OF THE PUBLIC RECORDS OF SARASOTA COUNTY, FLORIDA.

Any person claiming an interest in the surplus from the sale, if any, other than the property owner as of the date of the Lis Pendens must file a claim within 60 days after the sale.

If you are a person with a disability who needs any accommodation in order to participate in this proceeding, you are entitled, at no cost to you, to the provision of certain assistance. Please contact the Sarasota County Jury Office, P.O. Box 3079, Sarasota, Florida 34230-3079, (941)861-7400, at least seven (7) days before your scheduled court appearance, or immediately upon receiving this notification if the time before the scheduled appearance is less than seven (7) days; if you are hearing or voice impaired, call 711.

By: Stephen Orsillo, Esq.,
FBN: 89377
9409 Philadelphia Road
Baltimore, Maryland 21237

MORRIS|HARDWICK|
SCHNEIDER, LLC
5110 Eisenhower Blvd.,
Suite 302A
Tampa, Florida 33634
Customer Service (866)-503-4930
MHSinbox@closingsource.net
FL-97001688-09
9238177
December 13, 20, 2013 13-05810S

SECOND INSERTION

NOTICE OF FORECLOSURE SALE
IN THE CIRCUIT COURT OF THE
TWELFTH JUDICIAL CIRCUIT
IN AND FOR SARASOTA COUNTY,
FLORIDA
CIVIL ACTION
CASE NO.: 58-2013-CA-000627 NC
DIVISION: A

WELLS FARGO BANK, N.A.,
Plaintiff, vs.
THE UNKNOWN
HEIRS, DEVISEES, GRANTEEES,
ASSIGNEES, LIENORS,
CREDITORS, TRUSTEES, OR
OTHER CLAIMANTS CLAIMING
BY, THROUGH, UNDER, OR
AGAINST ELROY D. CROSS A/K/A

ELROY DAVID CROSS A/K/A
DAVID E. CROSS, DECEASED,
et al,
Defendant(s).

NOTICE IS HEREBY GIVEN pursuant to a Final Judgment of Mortgage Foreclosure dated December 4, 2013 and entered in Case No. 58-2013-CA-000627 NC of the Circuit Court of the Twelfth Judicial Circuit in and for SARASOTA County, Florida wherein WELLS FARGO BANK, N.A. is the Plaintiff and THE UNKNOWN HEIRS, DEVISEES, GRANTEEES, ASSIGNEES, LIENORS, CREDITORS, TRUSTEES, OR OTHER

CLAIMANTS CLAIMING BY, THROUGH, UNDER, OR AGAINST ELROY D. CROSS A/K/A ELROY DAVID CROSS A/K/A DAVID E. CROSS, DECEASED; SIERRA MARIE CROSS AS HEIR OF THE ESTATE OF ELROY D. CROSS A/K/A ELROY DAVID CROSS A/K/A DAVID E. CROSS, DECEASED; VALERIE KAY ESPOSITO; ANY AND ALL UNKNOWN PARTIES CLAIMING BY, THROUGH, UNDER, AND AGAINST THE HEREIN NAMED INDIVIDUAL DEFENDANT(S) WHO ARE NOT KNOWN TO BE DEAD OR ALIVE, WHETHER SAID UNKNOWN

PARTIES MAY CLAIM AN INTEREST AS SPOUSES, HEIRS, DEVISEES, GRANTEEES, OR OTHER CLAIMANTS; are the Defendants, The Clerk will sell to the highest and best bidder for cash at WWW.SARASOTA.REALFORECLOSE.COM at 9:00AM, on the 9th day of January, 2014, the following described property as set forth in said Final Judgment:

LOT 24 AND THE EAST 1/2 OF LOT 25, A RESTFUL PINES SUBDIVISION, AS PER PLAT THEREOF RECORDED IN PLAT BOOK 8, PAGE 122, OF THE PUBLIC RECORDS

OF SARASOTA COUNTY, FLORIDA.

A/K/A 3211 RESTFUL LANE, SARASOTA, FL 34231-7340
Any person claiming an interest in the surplus from the sale, if any, other than the property owner as of the date of the Lis Pendens must file a claim within sixty (60) days after the sale.

If you are a person with a disability who needs any accommodation in order to participate in this proceeding, you are entitled, at no cost to you, to the provision of certain assistance. Please contact the Sarasota County Jury Office, P.O. Box

3079, Sarasota, Florida 34230-3079, (941)861-7400, at least seven (7) days before your scheduled court appearance, or immediately upon receiving this notification if the time before the scheduled appearance is less than seven (7) days; if you are hearing or voice impaired, call 711.

By: Victoria S. Jones
Florida Bar No. 52252
Ronald R Wolfe & Associates, P.L.
P.O. Box 25018
Tampa, Florida 33622-5018
(813) 251-4766
(813) 251-1541 Fax
F12018094
December 13, 20, 2013 13-05832S



SECOND INSERTION

NOTICE TO CREDITORS
IN THE CIRCUIT COURT FOR
SARASOTA COUNTY, FLORIDA
PROBATE DIVISION
File No. 2013 CP 4056
IN RE: ESTATE OF
VALDOMIRO STRYZAKOWSKI,
Deceased.

The administration of the estate of Valdomiro Stryzakowski, deceased, whose date of death was August 24, 2013, is pending in the Circuit Court for Sarasota County, Florida, Probate Division, File No 2013CP4056 the address of which is 2000 Main Street, Sarasota, FL 34237. The names and addresses of the Personal Representative and the Personal Representative's attorney are set forth below.

All creditors of the decedent and other persons, having claims or demands against decedent's estate, on whom a copy of this notice is required to be served must file their claims with this court WITHIN THE LATER OF THREE (3) MONTHS AFTER THE TIME OF THE FIRST PUBLICATION OF THIS NOTICE OR THIRTY (30) DAYS AFTER THE DATE OF SERVICE OF A COPY OF THIS NOTICE ON THEM.

All other creditors of the decedent and other persons having claims or demands against decedent's estate must file their claims with this court WITHIN THREE (3) MONTHS AFTER THE DATE OF THE FIRST PUBLICATION OF THIS NOTICE.

ALL CLAIMS NOT FILED WITHIN THE TIME PERIODS SET FORTH IN SECTION 733.702 OF THE FLORIDA PROBATE CODE WILL BE FOREVER BARRED.

NOTWITHSTANDING THE TIME PERIODS SET FORTH ABOVE, ANY CLAIM FILED TWO (2) YEARS OR MORE AFTER THE DECEDENT'S DATE OF DEATH IS BARRED.

THE DATE OF FIRST PUBLICATION OF THIS NOTICE IS DECEMBER 13, 2013.

Personal Representative
Valdomiro Bileckij
15385 Garden Road
Poway, CA 92064

Attorney for Personal Representative
Bruce A. McDonald
Florida Bar No. 263311
McDonald Fleming Moorhead
d/b/a Statewide Probate
25 West Government Street
Pensacola, FL 32502
(850) 477-0660
(850) 477-0982 FAX
bamcdonald@pensacolalaw.com
mmstoner@pensacolalaw.com
December 13, 20, 2013 13-05851S

SECOND INSERTION

NOTICE TO CREDITORS
IN THE CIRCUIT COURT FOR
SARASOTA COUNTY, FLORIDA
PROBATE DIVISION
File No. 2013 CP 4157 NC
Division Probate
IN RE: ESTATE OF
DANUTA T. ZANDEL
Deceased.

The administration of the estate of Danuta T. Zandel, deceased, whose date of death was August 29, 2012, is pending in the Circuit Court for Sarasota County, Florida, Probate Division, the address of which is 2000 Main Street, Sarasota, FL 34237. The names and addresses of the personal representative and the personal representative's attorney are set forth below.

All creditors of the decedent and other persons having claims or demands against decedent's estate on whom a copy of this notice is required to be served must file their claims with this court WITHIN THE LATER OF 3 MONTHS AFTER THE TIME OF THE FIRST PUBLICATION OF THIS NOTICE OR 30 DAYS AFTER THE DATE OF SERVICE OF A COPY OF THIS NOTICE ON THEM.

All other creditors of the decedent and other persons having claims or demands against decedent's estate must file their claims with this court WITHIN 3 MONTHS AFTER THE DATE OF THE FIRST PUBLICATION OF THIS NOTICE.

ALL CLAIMS NOT FILED WITHIN THE TIME PERIODS SET FORTH IN SECTION 733.702 OF THE FLORIDA PROBATE CODE WILL BE FOREVER BARRED.

NOTWITHSTANDING THE TIME PERIODS SET FORTH ABOVE, ANY CLAIM FILED TWO (2) YEARS OR MORE AFTER THE DECEDENT'S DATE OF DEATH IS BARRED.

The date of first publication of this notice is October 4, 2013.

Personal Representative:
Ira S. Wiesner

328 N. Rhodes Avenue
Sarasota, Florida 34231
Attorney for Personal Representative:
Ira S. Wiesner
Attorney for Ira S. Wiesner
Florida Bar Number: 222887
Professional Assoc., Advocates
in Aging
328 N. Rhodes Avenue
Sarasota, Florida 34237
Telephone: (941) 365-9900
Fax: (941) 365-4479
E-Mail: advocates@wiesnerlaw.com
Secondary E-Mail:
sarah@wiesnerlaw.com
December 13, 20, 2013 13-05815S

SECOND INSERTION

NOTICE TO CREDITORS
IN THE CIRCUIT COURT FOR
SARASOTA COUNTY, FLORIDA
PROBATE DIVISION
File No. 2013-CP-004259-NC
IN RE: ESTATE OF
JOSHUA ADAMS,
Deceased.

The administration of the estate of JOSHUA ADAMS, deceased, whose date of death was April 26, 2012, is pending in the Circuit Court for Sarasota County, Florida, Probate Division, the address of which is P.O. Box 3079, Sarasota, Florida 34230. The names and addresses of the personal representative and the personal representative's attorney are set forth below.

All creditors of the decedent and other persons having claims or demands against decedent's estate on whom a copy of this notice is required to be served must file their claims with this court ON OR BEFORE THE LATER OF 3 MONTHS AFTER THE TIME OF THE FIRST PUBLICATION OF THIS NOTICE OR 30 DAYS AFTER THE DATE OF SERVICE OF A COPY OF THIS NOTICE ON THEM.

All other creditors of the decedent and other persons having claims or demands against decedent's estate must file their claims with this court WITHIN 3 MONTHS AFTER THE DATE OF THE FIRST PUBLICATION OF THIS NOTICE.

ALL CLAIMS NOT FILED WITHIN THE TIME PERIODS SET FORTH IN SECTION 733.702 OF THE FLORIDA PROBATE CODE WILL BE FOREVER BARRED.

NOTWITHSTANDING THE TIME PERIOD SET FORTH ABOVE, ANY CLAIM FILED TWO (2) YEARS OR MORE AFTER THE DECEDENT'S DATE OF DEATH IS BARRED.

The date of first publication of this notice is December 13, 2013.

Personal Representative:
Patricia Adams

3703 Helene Street
Sarasota, Florida 34233
Attorney for Personal Representative:
Christopher G. Brandon
Florida Bar No. 72469
Williams Parker Harrison
Dietz & Getzen
200 S. Orange Ave.
Sarasota, FL 34236
Telephone: 941-366-4800
Designation of Email Addresses for service:
Primary:
cbrandon@williamsparker.com
Secondary:
mtaylor@williamsparker.com
December 13, 20, 2013 13-05817S

SECOND INSERTION

NOTICE TO CREDITORS
IN THE CIRCUIT COURT FOR
SARASOTA COUNTY, FLORIDA
PROBATE DIVISION
File No. 2013 CP 4515 NC
Division PR
IN RE: ESTATE OF
ADRIAN L. FERGUSON, SR,
Deceased

The administration of the estate of ADRIAN L. FERGUSON, SR., deceased, whose date of death was June 13, 2013; File Number 2013 CP 4515 NC, is pending in the Circuit Court for Sarasota County, Florida, Probate Division, the address of which is P.O. Box 3079, Sarasota, FL 34230-3079. The names and addresses of the personal representative and the personal representative's attorney are set forth below.

All creditors of the decedent and other persons having claims or demands against decedent's estate, on whom a copy of this notice is required to be served, must file their claims with this court ON OR BEFORE THE LATER OF 3 MONTHS AFTER THE TIME OF THE FIRST PUBLICATION OF THIS NOTICE OR 30 DAYS AFTER THE DATE OF SERVICE OF A COPY OF THIS NOTICE ON THEM

All other creditors of the decedent and other persons having claims or demands against decedent's estate must file their claims with this court WITHIN 3 MONTHS AFTER THE DATE OF THE FIRST PUBLICATION OF THIS NOTICE

ALL CLAIMS NOT FILED WITHIN THE TIME PERIODS SET FORTH IN SECTION 733.702 OF THE FLORIDA PROBATE CODE WILL BE FOREVER BARRED

NOT WITHSTANDING THE TIME PERIOD SET FORTH ABOVE, ANY CLAIM FILED TWO (2) YEARS OR MORE AFTER THE DECEDENT'S DATE OF DEATH IS BARRED

The date of first publication of this notice is: December 13, 2013.

Personal Representative:
SUNTRUST BANK

401 East Jackson Street, 19th Floor
Tampa, FL 33602
Attorney for Personal Representative:
W. LEE MCGINNESS, ESQUIRE
MacLeod, McGinness & Bowman, PA
1800 Second Street,
Suite 971
Sarasota, FL 34236
Florida Bar No. 0520550
Telephone: (941) 954-8788
Email: lee@mandm-law.com
Secondary Email:
judy@mandm-law.com
December 13, 20, 2013 13-05806S

SECOND INSERTION

NOTICE TO CREDITORS
IN THE CIRCUIT COURT FOR
SARASOTA COUNTY, FLORIDA
PROBATE DIVISION
File No. 2013 CP 4458 NC
Division PR
IN RE: ESTATE OF
HELEN L BARNES,
Deceased.

The administration of the estate of HELEN L BARNES, deceased, whose date of death was October 1, 2013; File Number 2013 CP 4458 NC, is pending in the Circuit Court for Sarasota County, Florida, Probate Division, the address of which is P.O. Box 3079, Sarasota, FL 34230-3079. The names and addresses of the personal representative and the personal representative's attorney are set forth below.

All creditors of the decedent and other persons having claims or demands against decedent's estate, on whom a copy of this notice is required to be served, must file their claims with this court ON OR BEFORE THE LATER OF 3 MONTHS AFTER THE TIME OF THE FIRST PUBLICATION OF THIS NOTICE OR 30 DAYS AFTER THE DATE OF SERVICE OF A COPY OF THIS NOTICE ON THEM

All other creditors of the decedent and other persons having claims or demands against decedent's estate must file their claims with this court WITHIN 3 MONTHS AFTER THE DATE OF THE FIRST PUBLICATION OF THIS NOTICE

ALL CLAIMS NOT FILED WITHIN THE TIME PERIODS SET FORTH IN SECTION 733.702 OF THE FLORIDA PROBATE CODE WILL BE FOREVER BARRED

NOTWITHSTANDING THE TIME PERIOD SET FORTH ABOVE, ANY CLAIM FILED TWO (2) YEARS OR MORE AFTER THE DECEDENT'S DATE OF DEATH IS BARRED

The date of first publication of this notice is: December 13, 2013.

Personal Representative:
CAROL S. KELLEY

4B Apple Ledge Dr.
Portland, ME 04103
Attorney for Personal Representative
ALICE S. BOWMAN, ESQUIRE
MacLeod, McGinness & Bowman, P A
1800 Second Street,
Suite 971
Sarasota, FL 34236
Telephone: (941) 954-8788
Florida Bar No. 0978485
Email: alice@mandm-law.com
Secondary Email:
judy@mandm-law.com
December 13, 20, 2013 13-05814S

SECOND INSERTION

NOTICE TO CREDITORS
IN THE CIRCUIT COURT FOR
SARASOTA COUNTY, FLORIDA
PROBATE DIVISION
File No. 2013CP 4410 NC
IN RE: ESTATE OF
EVELYN P. STAMBAUGH
Deceased.

The administration of the estate of EVELYN P. STAMBAUGH, deceased, whose date of death was July 17, 2013; File Number 2013CP 4410 NC, is pending in the Circuit Court for Sarasota County, Florida, Probate Division, the address of which is P.O. Box 3079, Sarasota, FL 34230. The names and addresses of the personal representative and the personal representative's attorney are set forth below.

All creditors of the decedent and other persons having claims or demands against decedent's estate, on whom a copy of this notice is required to be served must file their claims with this court WITHIN THE LATER OF 3 MONTHS AFTER THE TIME OF THE FIRST PUBLICATION OF THIS NOTICE OR 30 DAYS AFTER THE DATE OF SERVICE OF A COPY OF THIS NOTICE ON THEM.

All other creditors of the decedent and other persons having claims or demands against decedent's estate must file their claims with this court WITHIN 3 MONTHS AFTER THE DATE OF THE FIRST PUBLICATION OF THIS NOTICE.

ALL CLAIMS NOT FILED WITHIN THE TIME PERIODS SET FORTH IN SECTION 733.702 OF THE FLORIDA PROBATE CODE WILL BE FOREVER BARRED.

NOTWITHSTANDING THE TIME PERIOD SET FORTH ABOVE, ANY CLAIM FILED TWO (2) YEARS OR MORE AFTER THE DECEDENT'S DATE OF DEATH IS BARRED.

The date of first publication of this notice is: December 13, 2013.

Personal Representative
RONALD D. STAMBAUGH

2333 Seward Drive
Sarasota, FL 34234
H. Greg Lee
Attorney for Personal Representative
Email: hglee@hgreglee.com
Florida Bar No. 351301
H. GREG LEE, P.A.
2014 Fourth St.
Sarasota Florida 34237
Telephone: 941-954-0067
Facsimile: 941-365-1492
December 13, 20, 2013 13-05838S

SECOND INSERTION

NOTICE TO CREDITORS
IN THE CIRCUIT COURT FOR
SARASOTA COUNTY, FLORIDA
PROBATE DIVISION
File No. 2013 CP 4431 NC
IN RE: ESTATE OF
LOIS E. HAIL A/K/A LOIS E. JAMES OR LOIS E. BANE,
Deceased.

The administration of the Estate of Lois E. Hail (a/k/a Lois E. James or Lois E. Bane), deceased, whose date of death was October 6, 2013, File Number 2013 CP 4431 NC, is pending in the Circuit Court for Sarasota County, Florida, Probate Division, the address of which is Historic Courthouse, 2000 Main Street, Room 102, Sarasota, Florida 34237. The names and addresses of the Personal Representative and the Personal Representative's attorney are set forth below.

All creditors of the decedent and other persons having claims or demands against decedent's estate on whom a copy of this notice has been served must file their claims with this Court WITHIN THE LATER OF 3 MONTHS AFTER THE DATE OF SERVICE OF THE FIRST PUBLICATION OF THIS NOTICE OR 30 DAYS AFTER THE TIME OF SERVICE OF A COPY OF THIS NOTICE ON THEM.

All other creditors of the decedent and other persons having claims or demands against decedent's estate must file their claims with this Court WITHIN 3 MONTHS AFTER THE DATE OF THE FIRST PUBLICATION OF THIS NOTICE.

ALL CLAIMS NOT SO FILED WILL BE FOREVER BARRED.
NOTWITHSTANDING THE TIME PERIOD SET FORTH ABOVE, ANY CLAIM FILED TWO (2) YEARS OR MORE AFTER THE DECEDENT'S DEATH IS BARRED.

The date of first publication of this notice is December 13, 2013.

Personal Representative
Matthew M. Bane

203 Brookwood Drive
Chattanooga, TN 37411
Attorney for the
Personal Representative
Susan Adinamis Michael
Florida Bar No. 0050792
Adinamis Michael & Saunders, P.C.
500 E. 96th Street, Suite 360
Indianapolis, IN 46240
317-218-2600
December 13, 20, 2013 13-05833S

SECOND INSERTION

NOTICE TO CREDITORS
IN THE CIRCUIT COURT FOR
SARASOTA COUNTY, FLORIDA
PROBATE DIVISION
File No. 2013-CP-003285-NC
Division Probate
IN RE: ESTATE OF
GRETA L. YATES
Deceased.

The administration of the estate of Greta L. Yates, deceased, whose date of death was May 17, 2013, is pending in the Circuit Court for Sarasota County, Florida, Probate Division, the address of which is 2000 Main Street, Sarasota, Florida 34236. The names and addresses of the personal representative and the personal representative's attorney are set forth below.

All creditors of the decedent and other persons having claims or demands against decedent's estate on whom a copy of this notice is required to be served must file their claims with this court WITHIN THE LATER OF 3 MONTHS AFTER THE TIME OF THE FIRST PUBLICATION OF THIS NOTICE OR 30 DAYS AFTER THE DATE OF SERVICE OF A COPY OF THIS NOTICE ON THEM.

All other creditors of the decedent and other persons having claims or demands against decedent's estate must file their claims with this court WITHIN 3 MONTHS AFTER THE DATE OF THE FIRST PUBLICATION OF THIS NOTICE.

ALL CLAIMS NOT FILED WITHIN THE TIME PERIODS SET FORTH IN SECTION 733.702 OF THE FLORIDA PROBATE CODE WILL BE FOREVER BARRED.

NOTWITHSTANDING THE TIME PERIODS SET FORTH ABOVE, ANY CLAIM FILED TWO (2) YEARS OR MORE AFTER THE DECEDENT'S DATE OF DEATH IS BARRED.

The date of first publication of this notice is December 13, 2013.

Personal Representative:
L. Howard Payne

240 S. Pineapple Avenue, Suite 401
Sarasota, Florida 34236
Attorney for Personal Representative:
David W. Payne
Attorney for L. Howard Payne
Florida Bar Number: 0958530
PAYNE LAW GROUP, P.A.
240 S Pineapple Ave,
Suite 401
Sarasota, FL 34236
Telephone: (941) 487-2801
December 13, 20, 2013 13-05834S

SECOND INSERTION

NOTICE TO CREDITORS
IN THE CIRCUIT COURT FOR
SARASOTA COUNTY, FLORIDA
PROBATE DIVISION
File No. 2013 CP 004336 NC
IN RE: ESTATE OF
WILLIAM G. RUSSELL
Deceased.

The administration of the estate of WILLIAM G. RUSSELL, deceased, whose date of death was February 24, 2013, is pending in the Circuit Court for SARASOTA County, Florida, Probate Division, the address of which is 2000 Main Street, Sarasota, FL 34236. The names and addresses of the personal representative and the personal representative's attorney are set forth below.

All creditors of the decedent and other persons having claims or demands against decedent's estate on whom a copy of this notice is required to be served must file their claims with this court WITHIN THE LATER OF 3 MONTHS AFTER THE TIME OF THE FIRST PUBLICATION OF THIS NOTICE OR 30 DAYS AFTER THE DATE OF SERVICE OF A COPY OF THIS NOTICE ON THEM.

All other creditors of the decedent and other persons having claims or demands against decedent's estate must file their claims with this court WITHIN 3 MONTHS AFTER THE DATE OF THE FIRST PUBLICATION OF THIS NOTICE.

ALL CLAIMS NOT FILED WITHIN THE TIME PERIODS SET FORTH IN SECTION 733.702 OF THE FLORIDA PROBATE CODE WILL BE FOREVER BARRED.

NOTWITHSTANDING THE TIME PERIODS SET FORTH ABOVE, ANY CLAIM FILED TWO (2) YEARS OR MORE AFTER THE DECEDENT'S DATE OF DEATH IS BARRED.

The date of first publication of this notice is 12-13-13.

Personal Representative:
DEBRA L. HANAWAY

1204 Mayfair Drive
Carpentersville, Illinois 60110
Attorney for Personal Representative:
ELIZABETH J. BARBER
Attorney for DEBRA L. HANAWAY
Florida Bar Number: 0058183
DUNLAP & MORAN, P.A.
Post Office Box 3948
Sarasota, FL 34230
Telephone: (941) 366-0115
Fax: (941) 365-4660
E-Mail: ebarber@dunlapmoran.com
December 13, 20, 2013 13-05871S

SECOND INSERTION

NOTICE OF PUBLIC SALE

The following vehicle/vessel(s) will be auctioned in FL for unpaid towing & storage charges only per FS 713.78 @: 134 Toney Penna Dr Unit 10 Jupiter 2004 FORD Explorer Sport Trac UT BLU 1FMZU67K04UA38988 12741 Metro Py Suite 2 Fort Myers 2003 DODG STRATUS 2D BLK 4B3AG42G13E076920 1968 Custom Drive Fort Myers 2000 HOND MAGNA 750C MC BLK/ORG JH2RC4333YM500161 3047 Terrace Ave Naples 1996 CHEV CAVALIER 4D WHI 1G1JC5243T7219287 1998 OLDS CUTLASS 4D SIL 1G3N-B52MOW6314685 6025 S R553 Madison 1998 DODG GRAND CARAVAN SW TAN 1B4GP44R7WB568203 100 Toney Penna Dr Jupiter 2002 JAGU S-Type 4D GRN SAJFA01P-62GM42621 2005 HOND CIVIC 4D BLU JHMES96625S020888 1508 Viscaya Pkwy Cape Coral 2002 FORD FOCUS 4D BLU 1FAHP34PX2W297713 13081 Metro Py Fort Myers 2003 PONT GRAND AM 4D WHI 1G2NE-52F53C138596 On DEC 30 2013 at 9:00 am at 115C Corporation Way Venice FL 134 Toney Penna Dr Unit 10 Jupiter 2006 NISS ALTIMA 4D 1N4AL1D06N392305 3047 Terrace Ave Naples 1995 FORD EXPLORER UT WHI 1FMDU34X7SUC26946 1991 TOYT CELICA CV WHI JT5ST-87K0M0082626 1992 NISS STANZA 4D WHI JN1FU21P2NX901751 2003 CHEV TRAILBLAZER UT BLU 1GNDT13S63Z166440 1998 JAGU XJ8 4D LGR SAJHX1244WC845382 5693 Sarah Ave Sarasota 1996 TOYT CAMRY 4D TAN 4T1BG12K-1TU765610 13081 Metro Py Fort Myers 1995 NISS PATHFINDER UT GRY JN8HD17Y6SW108815 On JAN 06 2014 at 9:00 am at 115C Corporation Way Venice FL Per FS713.585(6), Elsie Title Services of SW FL, LLC w/POA will sell listed units to highest bidder free of any liens; Net deposited with clerk of court per 713.585; owner/lienholders right to a hearing per FS713.585(6); to post bond per FS559.917; owner may redeem for cash sum of lien; held w/reserve; inspect 1 wk prior @ lienor facility; cash or cashier's check; 25% buyers prem. Sale @ KEENE AUTOMOTIVE, LLC dba KEENE AUTOMOTIVE 1171 SNEAD AVE SARASOTA FL 34239-2931 MV-38561 941-363-9416 1/23/2014 @ 9:00am - Storage @ \$26.75 per day inc tax KEEN M3 lien amt \$1,990.20 1970 CHEV CHEVELLE 2D PRI 1333701539770 December 13, 2013 13-05841S

SECOND INSERTION

NOTICE TO CREDITORS
IN THE CIRCUIT COURT FOR
SARASOTA COUNTY, FLORIDA
PROBATE DIVISION
File No. 2013 CP 4463 NC
IN RE: ESTATE OF
KENNETH C. DICKEY,
Deceased.

The administration of the estate of KENNETH C. DICKEY, deceased, whose date of death was October 25, 2013, is pending in the Circuit Court for Sarasota County, Florida, Probate Division, the address of which is P.O. Box 3079, Sarasota, FL 34230. The names and addresses of the personal representative and the personal representative's attorney are set forth below.

All creditors of the decedent and other persons having claims or demands against decedent's estate on whom a copy of this notice is required to be served must file their claims with this court ON OR BEFORE THE LATER OF 3 MONTHS AFTER THE TIME OF THE FIRST PUBLICATION OF THIS NOTICE OR 30 DAYS AFTER THE DATE OF SERVICE OF A COPY OF THIS NOTICE ON THEM.

All other creditors of the decedent and other persons having claims or demands against decedent's estate must file their claims with this court WITHIN 3 MONTHS AFTER THE DATE OF THE FIRST PUBLICATION OF THIS NOTICE.

ALL CLAIMS NOT FILED WITHIN THE TIME PERIODS SET FORTH IN SECTION 733.702 OF THE FLORIDA PROBATE CODE WILL BE FOREVER BARRED.

NOTWITHSTANDING THE TIME PERIOD SET FORTH ABOVE, ANY CLAIM FILED TWO (2) YEARS OR MORE AFTER THE DECEDENT'S DATE OF DEATH IS BARRED.

The date of first publication of this notice is December 13, 2013.

Personal Representative:
LYNETTE D. O'HARA

140 Main Street
Rockport, ME 04856
Attorney for Personal Representative:
ELIZABETH C. MARSHALL
Florida Bar No. 0440884
Williams Parker
Harrison Dietz & Getzen
200 S. Orange Ave.
Sarasota, FL 34236
Telephone: 941-366-4800
Designation of
Email Addresses for service:
Primary:
emarshall@williamsparker.com
Secondary: bbird@williamsparker.com
December 13, 20, 2013 13-05808S

SECOND INSERTION

NOTICE TO CREDITORS
IN THE CIRCUIT COURT FOR
SARASOTA COUNTY, FLORIDA
PROBATE DIVISION
File No. 2013 CP 4457 NC
Division PR
IN RE: ESTATE OF
MARGARET R. IRVING,
Deceased.

The administration of the estate of MARGARET R. IRVING, deceased, whose date of death was August 15, 2013; File Number 2013 CP 4457 NC, is pending in the Circuit Court for Sarasota County, Florida, Probate Division, the address of which is P.O. Box 3079, Sarasota, FL 34230-3079. The names and addresses of the personal representative and the personal representative's attorney are set forth below.

All creditors of the decedent and other persons having claims or demands against decedent's estate, on whom a copy of this notice is required to be served, must file their claims with this court ON OR BEFORE THE LATER OF 3 MONTHS AFTER THE TIME OF THE FIRST PUBLICATION OF THIS NOTICE OR 30 DAYS AFTER THE DATE OF SERVICE OF A COPY OF THIS NOTICE ON THEM

All other creditors of the decedent and other persons having claims or demands against decedent's estate must file their claims with this court WITHIN 3 MONTHS AFTER THE DATE OF THE FIRST PUBLICATION OF THIS NOTICE

ALL CLAIMS NOT FILED WITHIN THE TIME PERIODS SET FORTH IN SECTION 733.702 OF THE FLORIDA PROBATE CODE WILL BE FOREVER BARRED

NOTWITHSTANDING THE TIME PERIOD SET FORTH ABOVE, ANY CLAIM FILED TWO (2) YEARS OR MORE AFTER THE DECEDENT'S DATE OF DEATH IS BARRED

The date of first publication of this notice is: December 13, 2013.

Personal Representative:
MERRIDY M SCOTT

212 Sheridan Rd
Kenilworth, IL 60043
Attorney for Personal Representative
ALICE S. BOWMAN, ESQUIRE
MacLeod, McGinness & Bowman, P A
1800 Second Street, Suite 971
Sarasota, FL 34236
Telephone: (941) 954-8788
Florida Bar No 0978485
Email: alice@mandm-law.com
Secondary Email:
judy@mandm-law.com
December 13, 20, 2013 13-05813S

THIRD INSERTION

NOTICE OF ACTION
(formal notice by publication)
IN THE CIRCUIT COURT FOR
SARASOTA COUNTY, FLORIDA
PROBATE DIVISION
File No.: 2013 CP 4444 NC
IN RE: ESTATE OF
EBONY KRISTEN CONNOR,
Deceased.

TO:
YESENIA RODRIGUEZ Unknown
YOU ARE NOTIFIED that a Petition for Administration has been filed in this court. You are required to serve a copy of your written defenses, if any, on the petitioner's attorney, whose name and address are: Robert D. Hines, Hines Norman Hines, P.A., 1312 W. Fletcher Avenue, Suite B, Tampa, FL 33612 on or before Jan 6, 2014, and to file the original of the written defenses with the clerk of this court either before service or immediately thereafter. Failure to serve and file written defenses as required may result in a judgment or order for the relief demanded, without further notice.

Signed on November 22, 2013.
KAREN E. RUSHING, CLERK
As Clerk of the Court
(SEAL) C. Brandenburg
As Deputy Clerk

Robert D. Hines
Attorney for Personal Representative
Email: rhines@hnh-law.com
Florida Bar No. 0413550
HINES NORMAN HINES, P.L.
1312 W. Fletcher Avenue
Suite B
Tampa, FL 33612
Telephone: 813-265-0100
December 6, 13, 20, 27, 2013
13-05720S

SECOND INSERTION

Statement of Marketable Title Action to the attention of all Lot Owners, The Villas of Chestnut Creek, a subdivision
The Villas of Chestnut Creek Owners Association, Inc.
At a properly called Board of Directors' meeting, held at 2:00 p.m., at the Jacaranda Public Library, Venice, Florida on March 17, 2011, The Villas of Chestnut Creek Owners Association, Inc. (the "Association"), through its Board of Directors took action to ensure that the Declaration of Covenants and Restrictions for The Villas of Chestnut Creek, a subdivision, recorded in Official Records Book 1771, Page 2054, et seq., of the Public Records of Sarasota County, Florida, as may be amended from time to time, currently burdening the property of each and every member of the Association, retains its status as the source of marketable title with regard to the transfer of a member's residence. To this end, the Association has caused the notice required by Chapter 712, Florida Statutes, to be recorded in Instrument #2013159565 of the Public Records of Sarasota County, Florida on November 27, 2013. Copies of this notice and its attachments are available through the Association pursuant to the Association's governing documents regarding official records of the Association.
December 13, 20, 2013 13-05839S

SECOND INSERTION

PUBLIC NOTICE
Public Notice by Gradient Technologies LLC of summary judgment, permanent injunction and sanctions, additional damages and additional sanctions against Robert R. Holcomb, M.D. PhD by the United States Bankruptcy Court for the Middle District of Tennessee, Nashville division in the amounts of \$16,000,000 plus interest, penalties and other costs.
December 13, 20, 2013 13-05835S

SAVE TIME
E-mail your Legal Notice
legal@businessobserverfl.com
Sarasota / Manatee Counties
Hillsborough County
Pasco County
Pinellas County
Lee County
Collier County
Wednesday
Noon Deadline
Friday Publication
Business Observer
13-05835S

SECOND INSERTION

NOTICE TO CREDITORS
(Summary Administration)
IN THE CIRCUIT COURT FOR
SARASOTA COUNTY, FLORIDA
PROBATE DIVISION
File No. 2013 CP 004528 SC
IN RE: ESTATE OF
MARION V. KOVACH
Deceased.

TO ALL PERSONS HAVING CLAIMS OR DEMANDS AGAINST THE ABOVE ESTATE:

You are hereby notified that an Order of Summary Administration has been entered in the estate of Marion V. Kovach, deceased, File Number 2013 CP 004528 SC, by the Circuit Court for Sarasota County, Florida, Probate Division, the address of which is 2000 Main Street, Sarasota, FL 34237; that the decedent's date of death was September 3, 2013; that the total value of the estate is \$50,000 and that the names and addresses of those to whom it has been assigned by such order are:

Name	Address
Gary D. Kovach	19 Old Youngs Cove Road Candler, NC 28715
Jeffrey R. Kovach	741 Jays Way Ringgold, GA 30736
Gasper Kovach	2608 Coventry Ave. Lakeland, FL 33803

ALL INTERESTED PERSONS ARE NOTIFIED THAT:

All creditors of the estate of the decedent and persons having claims or demands against the estate of the decedent other than those for whom provision for full payment was made in the Order of Summary Administration must file their claims with this court WITHIN THE TIME PERIODS SET FORTH IN SECTION 733.702 OF THE FLORIDA PROBATE CODE. ALL CLAIMS AND DEMANDS NOT SO FILED WILL BE FOREVER BARRED. NOTWITHSTANDING ANY OTHER APPLICABLE TIME PERIOD, ANY CLAIM FILED TWO (2) YEARS OR MORE AFTER THE DECEDENT'S DATE OF DEATH IS BARRED.

The date of first publication of this Notice is December 13, 2013.

Persons Giving Notice:

Gary D. Kovach
19 Old Youngs Cove Road
Candler, NC 28715
Jeffrey R. Kovach
741 Jays Way
Ringgold, GA 30736
Gasper Kovach
2608 Coventry Ave.
Lakeland, FL 33803

Attorney for Persons Giving Notice:

Steven W. Ledbetter, Esq.
Attorney for Petitioners
Florida Bar Number: 41345
229 Pensacola Road
Venice, Florida 34285
Telephone: (941) 256-3965
Fax: (941) 866-7514
E-Mail: sledbetter@swllaw.com
Secondary E-Mail:
probate@swllaw.com
December 13, 20, 2013 13-05818S

SECOND INSERTION

NOTICE TO CREDITORS
IN THE CIRCUIT COURT FOR THE
TWELFTH JUDICIAL CIRCUIT, IN
AND FOR SARASOTA COUNTY,
FLORIDA
PROBATE DIVISION
FILE NO. 2010CP2982NC
IN RE: ESTATE OF
WILLIAM J. HUGHES,
Deceased.

The administration of the Estate of William J. Hughes, deceased, whose date of death was June 12, 2010, is pending in the Circuit Court for Sarasota County, Florida, Probate Division, the address of which is, Lynn N. Silver-tooth Judicial Center, 2002 Ringling Boulevard, Sarasota, FL 34237. The names and addresses of the personal representative and the personal representative's attorney are set forth below.

All creditors of the decedent and other persons having claims or demands against decedent's estate on whom a copy of this notice is required to be served must file their claims with this court WITHIN THE LATER OF 3 MONTHS AFTER THE TIME OF THE FIRST PUBLICATION OF THIS NOTICE OR 30 DAYS AFTER THE DATE OF SERVICE OF A COPY OF THIS NOTICE ON THEM.

All other creditors of the decedent and other persons having claims or demands against decedent's estate must file their claims with this court WITHIN 3 MONTHS AFTER THE DATE OF THE FIRST PUBLICATION OF THIS NOTICE. ALL CLAIMS NOT FILED WITHIN THE TIME PERIOD SET FORTH IN SECTION 733.702

SECOND INSERTION

NOTICE TO CREDITORS
(Summary Administration)
IN THE CIRCUIT COURT FOR
SARASOTA COUNTY, FLORIDA
PROBATE DIVISION
File No. 2013 CP 004585 SC
IN RE: ESTATE OF
JACQUELINE BURTON
Deceased.

TO ALL PERSONS HAVING CLAIMS OR DEMANDS AGAINST THE ABOVE ESTATE:

You are hereby notified that an Order of Summary Administration has been entered in the estate of Jacqueline Burton, deceased, File Number 2013 CP 004585 SC, by the Circuit Court for Sarasota County, Florida, Probate Division, the address of which is P.O. Box 3079, Sarasota, FL 34230-3079; that the decedent's date of death was October 3, 2012; that the total value of the estate is less than \$75,000.00 and that the names and addresses of those to whom it has been assigned by such order are:

Name	Address
KEITH BURTON	6 A Avion Avenue Toronto, Canada M4E1C3
Brent Burton	895 Lynwood Drive, Sudbury Ontario, Canada P3A 4N5
David Burton	1224 Canborough Crs., Pickering Ontario, Canada L1V 3K9

ALL INTERESTED PERSONS ARE NOTIFIED THAT:

All creditors of the estate of the decedent and persons having claims or demands against the estate of the decedent other than those for whom provision for full payment was made in the Order of Summary Administration must file their claims with this court WITHIN THE TIME PERIODS SET FORTH IN SECTION 733.702 OF THE FLORIDA PROBATE CODE. ALL CLAIMS AND DEMANDS NOT SO FILED WILL BE FOREVER BARRED. NOTWITHSTANDING ANY OTHER APPLICABLE TIME PERIOD, ANY CLAIM FILED TWO (2) YEARS OR MORE AFTER THE DECEDENT'S DATE OF DEATH IS BARRED.

The date of first publication of this Notice is December 13, 2013.

Persons Giving Notice:

KEITH BURTON
Petitioner
BRENT BURTON
Petitioner
DAVID BURTON
Petitioner

Attorney for Persons Giving Notice:

Steven W. Ledbetter, P.L.
Attorney for Petitioners
Florida Bar Number: 41345
229 Pensacola Road
Venice, Florida 34285
Telephone: (941) 866-7514
Fax: (941) 866-7514
E-Mail: sledbetter@swllaw.com
December 13, 20, 2013 13-05807S

SECOND INSERTION

NOTICE TO CREDITORS
IN THE CIRCUIT COURT FOR
SARASOTA COUNTY, FLORIDA
PROBATE DIVISION
File Number 2013-CP-4341 NC
IN RE: ESTATE OF
ROBERT C. SCHMID,
Deceased.

The administration of the ESTATE OF ROBERT C. SCHMID, deceased, whose date of death was August 6, 2013, is pending in the Circuit Court for Sarasota County, Florida, Probate Division, the address of which is P.O. Box 3079, Sarasota, Florida 34230. The names and addresses of the personal representative and the foreign personal representative's attorney are set forth below.

All creditors of the decedent and other persons having claims or demands against decedent's estate on whom a copy of this notice is required to be served must file their claims with this court WITHIN THE LATER OF 3 MONTHS AFTER THE TIME OF THE FIRST PUBLICATION OF THIS NOTICE OR 30 DAYS AFTER THE DATE OF SERVICE OF A COPY OF THIS NOTICE ON THEM.

All other creditors of the decedent and other persons having claims or demands against decedent's estate must file their claims with this court WITHIN 3 MONTHS AFTER THE DATE OF THE FIRST PUBLICATION OF THIS NOTICE.

ALL CLAIMS NOT FILED WITHIN THE TIME PERIODS SET FORTH IN SECTION 733.702 OF THE FLORIDA PROBATE CODE WILL BE FOREVER BARRED.

NOTWITHSTANDING THE TIME PERIODS SET FORTH ABOVE, ANY CLAIM FILED TWO (2) YEARS OR MORE AFTER THE DECEDENT'S DATE OF DEATH IS BARRED.

The date of the first publication of this Notice is 12/13, 2013.

Personal Representative:

WELLS FARGO BANK
By: **KATHRYN McCRAKEN**
Wealth Management Trust
Administrator
4801 Southwest Parkway,
Bldg 1, Suite 200
Austin, Texas 78735

Attorney for Personal Representative:

J. RONALD SKIPPER
Florida Bar No. 184366
FERGESON, SKIPPER, SHAW,
KEYSER, BARON & TIRABASSI, P.A.
1515 Ringling Boulevard, 10th Floor
P. O. Box 3018
Sarasota, Florida 34230-3018
(941) 957-1900
rskipper@fergesonskipper.com
services@fergesonskipper.com
442880.26780
December 13, 20, 2013 13-05819S

SECOND INSERTION

NOTICE TO CREDITORS
IN THE CIRCUIT COURT FOR
SARASOTA COUNTY, FLORIDA
PROBATE DIVISION
File Number 2013 CP 004598 NC
IN RE: ESTATE OF
GEORGE R. HAUSER,
Deceased.

The administration of the ESTATE OF GEORGE R. HAUSER, deceased, whose date of death was November 21, 2013, is pending in the Circuit Court for Sarasota County, Florida, Probate Division, the address of which is P.O. Box 3079, Sarasota, Florida 34230. The names and addresses of the personal representative and the personal representative's attorney are set forth below.

All creditors of the decedent and other persons having claims or demands against decedent's estate on whom a copy of this notice is required to be served must file their claims with this court WITHIN THE LATER OF 3 MONTHS AFTER THE TIME OF THE FIRST PUBLICATION OF THIS NOTICE OR 30 DAYS AFTER THE DATE OF SERVICE OF A COPY OF THIS NOTICE ON THEM.

All other creditors of the decedent and other persons having claims or demands against decedent's estate must file their claims with this court WITHIN 3 MONTHS AFTER THE DATE OF THE FIRST PUBLICATION OF THIS NOTICE.

ALL CLAIMS NOT FILED WITHIN THE TIME PERIODS SET FORTH IN SECTION 733.702 OF THE FLORIDA PROBATE CODE WILL BE FOREVER BARRED.

NOTWITHSTANDING THE TIME PERIODS SET FORTH ABOVE, ANY CLAIM FILED TWO (2) YEARS OR MORE AFTER THE DECEDENT'S DATE OF DEATH IS BARRED.

The date of the first publication of this Notice is December 13, 2013.

Personal Representative:

MARY JANE HAUSER
c/o P.O. Box 3018
Sarasota, Florida 34230
Attorney for Personal Representative:
JAMES O. FERGESON, JR.
Florida Bar No. 171298
FERGESON, SKIPPER, SHAW,
KEYSER, BARON & TIRABASSI, P.A.
1515 Ringling Boulevard, 10th Floor
P. O. Box 3018
Sarasota, Florida 34230-3018
(941) 957-1900
jfergeson@fergesonskipper.com
services@fergesonskipper.com
December 13, 20, 2013 13-05872S

SECOND INSERTION

NOTICE TO CREDITORS
IN THE CIRCUIT COURT FOR
SARASOTA COUNTY, FLORIDA
PROBATE DIVISION
File Number 2013 CP 004627 NC
IN RE: ESTATE OF
MARCELLA M. HAZAN,
Deceased.

The administration of the ESTATE OF MARCELLA M. HAZAN, deceased, whose date of death was September 29, 2013, is pending in the Circuit Court for Sarasota County, Florida, Probate Division, the address of which is P.O. Box 3079, Sarasota, Florida 34230. The names and addresses of the personal representative and the personal representative's attorney are set forth below.

All creditors of the decedent and other persons having claims or demands against decedent's estate on whom a copy of this notice is required to be served must file their claims with this court WITHIN THE LATER OF 3 MONTHS AFTER THE TIME OF THE FIRST PUBLICATION OF THIS NOTICE OR 30 DAYS AFTER THE DATE OF SERVICE OF A COPY OF THIS NOTICE ON THEM.

All other creditors of the decedent and other persons having claims or demands against decedent's estate must file their claims with this court WITHIN 3 MONTHS AFTER THE DATE OF THE FIRST PUBLICATION OF THIS NOTICE.

ALL CLAIMS NOT FILED WITHIN THE TIME PERIODS SET FORTH IN SECTION 733.702 OF THE FLORIDA PROBATE CODE WILL BE FOREVER BARRED.

NOTWITHSTANDING THE TIME PERIODS SET FORTH ABOVE, ANY CLAIM FILED TWO (2) YEARS OR MORE AFTER THE DECEDENT'S DATE OF DEATH IS BARRED.

The date of the first publication of this Notice is December 13, 2013.

Personal Representative:

VICTOR J. HAZAN
c/o P.O. Box 3018
Sarasota, Florida 34230

Attorney for Personal Representative:

JAMES O. FERGESON, JR.
Florida Bar No. 171298
FERGESON, SKIPPER, SHAW,
KEYSER, BARON & TIRABASSI, P.A.
1515 Ringling Boulevard, 10th Floor
P. O. Box 3018
Sarasota, Florida 34230-3018
(941) 957-1900
jfergeson@fergesonskipper.com
services@fergesonskipper.com
3916309.26773
December 13, 20, 2013 13-05873S

SECOND INSERTION

NOTICE TO CREDITORS
IN THE CIRCUIT COURT OF THE
TWELFTH JUDICIAL CIRCUIT, IN
AND FOR SARASOTA
COUNTY, FLORIDA
PROBATE DIVISION
File # 2013CP4465NC
IN RE: ESTATE OF
PETER D. McELMURRAY,
Deceased.

The name of the decedent, the designation of the court in which the administration of this estate is pending, and the file number are indicated above. The address of the court is Clerk of Court, P.O. Box 3079, Sarasota, FL 34230-3079. The names and addresses of the personal representative and the personal representative's attorney are indicated below.

If you have been served with a copy of this notice and you have any claim or demand against the decedent's estate, even if that claim is un-matured, contingent or unliquidated, you must file your claim with the court ON OR BEFORE THE LATER OF A DATE THAT IS 3 MONTHS AFTER THE DATE OF THE FIRST PUBLICATION OF THIS NOTICE OR 30 DAYS AFTER YOU RECEIVE A COPY OF THIS NOTICE.

All other creditors of the decedent and other persons who have claims or demands against the decedent's estate, including un-matured, contingent or unliquidated claims, must file their claims with the court WITHIN 3 MONTHS AFTER THE DATE OF THE FIRST PUBLICATION OF THIS NOTICE.

ALL CLAIMS NOT SO FILED WILL BE FOREVER BARRED.

EVEN IF A CLAIM IS NOT BARRED BY THE LIMITATIONS DESCRIBED ABOVE, ALL CLAIMS WHICH HAVE NOT BEEN FILED WILL BE BARRED TWO YEARS AFTER DECEDENT'S DEATH.

The date of death of the decedent is: September 5, 2013.

The date of first publication of this Notice is: December 13, 2013.

Petitioner:

Mary C. McElmurray,
Personal Rep.
1673 Sunrise Lane
Sarasota, FL 34231

Attorney for Petitioner:

AJ STICKELY, ESQUIRE
359 West Dearborn Street
Englewood, FL 34223
(941) 474-7768
Florida Bar No.: 0051605
December 13, 20, 2013 13-05877S

SECOND INSERTION

NOTICE TO CREDITORS
IN THE CIRCUIT COURT FOR
SARASOTA COUNTY, FLORIDA
PROBATE DIVISION
File No. 2013 CP 4593
Division Probate
IN RE: ESTATE OF
JOHN P. STEFANOFF
Deceased.

The administration of the estate of JOHN P. STEFANOFF, deceased, whose date of death was July 13, 2013, is pending in the Circuit Court for Sarasota County, Florida, Probate Division, the address of which is 2000 Main Street, Sarasota, FL 34237. The names and addresses of the personal representative and the personal representative's attorney are set forth below.

All creditors of the decedent and other persons having claims or demands against decedent's estate on whom a copy of this notice is required to be served must file their claims with this court ON OR BEFORE THE LATER OF A DATE THAT IS 3 MONTHS AFTER THE FIRST PUBLICATION OF THIS NOTICE OR 30 DAYS AFTER YOU RECEIVE A COPY OF THIS NOTICE.

All other creditors of the decedent and other persons having claims or demands against decedent's estate must file their claims with this court ON OR BEFORE THE DATE THAT IS 3 MONTHS AFTER THE FIRST PUBLICATION OF THIS NOTICE.

ALL CLAIMS NOT FILED WITHIN THE TIME PERIODS SET FORTH IN SECTION 733.702 OF THE FLORIDA PROBATE CODE WILL BE FOREVER BARRED.

NOTWITHSTANDING THE TIME PERIODS SET FORTH ABOVE, ANY CLAIM FILED TWO (2) YEARS OR MORE AFTER THE DECEDENT'S DATE OF DEATH IS BARRED.

The date of first publication of this notice is 12-13-2013.

Personal Representative:

TAMARA STEFANOFF

Attorney for Personal Representative:

Dana Laganella Gerling, Esq.
FL Bar No. 0503991
Affordable Attorney
Gerling Law Group Chartered
6148 State Road 70 East
Bradenton, Florida 34203
Telephone: (941) 756-6600
Email:
dlaganella@gerlinglawgroup.com
December 13, 20, 2013 13-05874S

SECOND INSERTION

NOTICE TO CREDITORS
IN THE CIRCUIT COURT FOR
SARASOTA COUNTY, FLORIDA
PROBATE DIVISION
File No. 2013 CP 4347 SC
IN RE: ESTATE OF
HOWARD P. SANBORN
Deceased.

The administration of the estate of HOWARD P. SANBORN, deceased, whose date of death was November 7, 2013, is pending in the Circuit Court for Sarasota County, Florida, Probate Division, the address of which is P.O. BOX 3079, SARASOTA, FL 34230. The names and addresses of the personal representative and the personal representative's attorney are set forth below.

All creditors of the decedent and other persons having claims or demands against decedent's estate on whom a copy of this notice is required to be served must file their claims with this court WITHIN THE LATER OF 3 MONTHS AFTER THE TIME OF THE FIRST PUBLICATION OF THIS NOTICE OR 30 DAYS AFTER THE DATE OF SERVICE OF A COPY OF THIS NOTICE ON THEM.

All other creditors of the decedent and other persons having claims or demands against decedent's estate must file their claims with this court WITHIN 3 MONTHS AFTER THE DATE OF THE FIRST PUBLICATION OF THIS NOTICE.

ALL CLAIMS NOT FILED WITHIN THE TIME PERIODS SET FORTH IN SECTION 733.702 OF THE FLORIDA PROBATE CODE WILL BE FOREVER BARRED.

NOTWITHSTANDING THE TIME PERIODS SET FORTH ABOVE, ANY CLAIM FILED TWO (2) YEARS OR MORE AFTER THE DECEDENT'S DATE OF DEATH IS BARRED.

The date of first publication of this notice is DECEMBER 13, 2013.

Personal Representative:

MARGARET SANBORN

c/o Village On The Isle
920 Tamiami Trail South, Apt. 554
Venice, Florida 34285

Attorney for Personal Representative:

STEPHEN K. BOONE, ESQ.
Attorney for Margaret Sanborn
Florida Bar Number: 0371068
BOONE BOONE BOONE KODA & FROOK PA
1001 AVENIDA DEL CIRCO
P. O. BOX 1596
VENICE, FL 34284
Telephone: (941) 488-6716
Fax: (941) 488-7079
E-Mail: sboone@boone-law.com
December 13, 20, 2013 13-05876S

SAVE TIME - EMAIL YOUR LEGAL NOTICES
Sarasota County • Manatee County • Hillsborough County • Charlotte County
Pinellas County • Pasco County • Lee County • Collier County • Charlotte County
legal@businessobserverfl.com
Wednesday Noon Deadline • Friday Publication

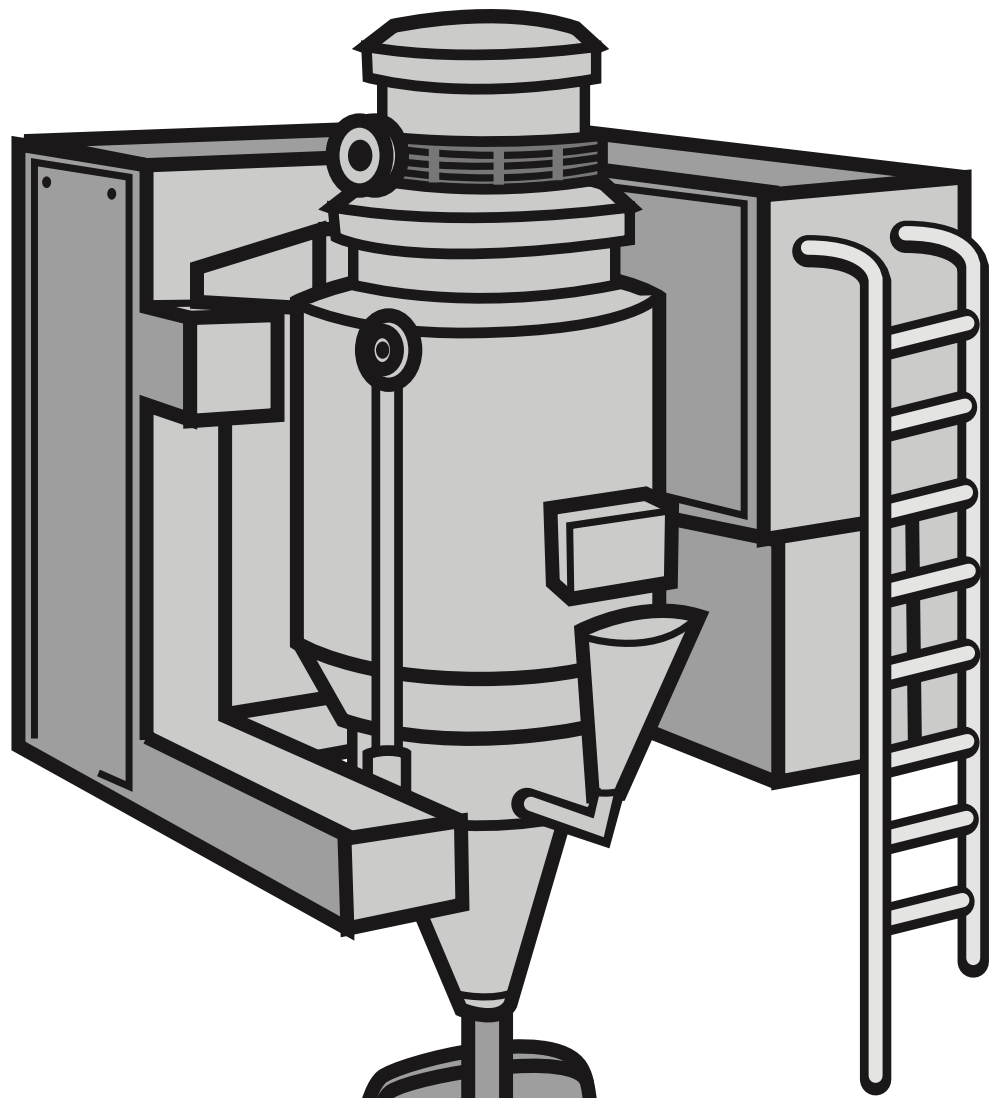

A special printing of
a classic story illustrating
the importance of
protecting capitalism.

TOM SMITH AND HIS INCREDIBLE BREAD MACHINE

By **R.W. Grant**

Illustrations by Austin McKinley

This is the legend of a man whose name
Was a household word: a man whose fame
Burst on the world like an atom bomb.
Smith was his last name; first name: Tom.

The argument goes on today.
"He was a villain," some will say.
"No! A hero!" others declare.
Or was he both? Well, I despair;
The fight will last 'til kingdom come;
Was Smith a hero? Or was Smith a bum?
So, listen to the story and it's up to you
To decide for yourself as to which is true!

Now, Smith, an inventor, had specialized
In toys. So people were surprised
When they found that he instead
Of making toys, was baking bread!
The news was flashed by CBS
Of his incredible success.
Then NBC jumped in in force,
Followed by the Times, of course.
The reason for their rapt attention,
The nature of his new invention,
The way to make bread he'd conceived
Cost less than people could believe!
And not just make it! This device
Could in addition wrap and slice!
The price per loaf, one loaf or many:
The miniscule sum of under one penny!

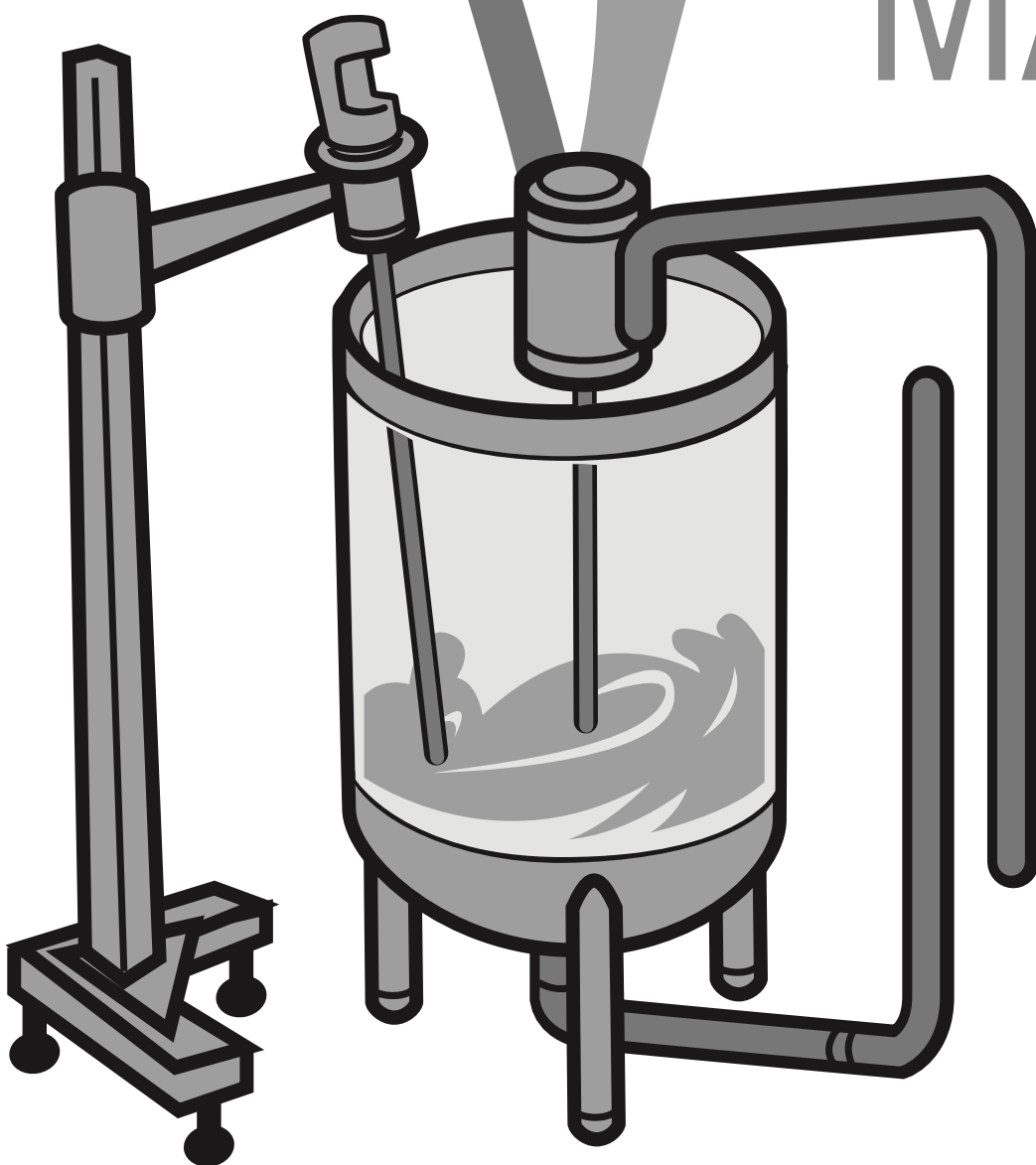

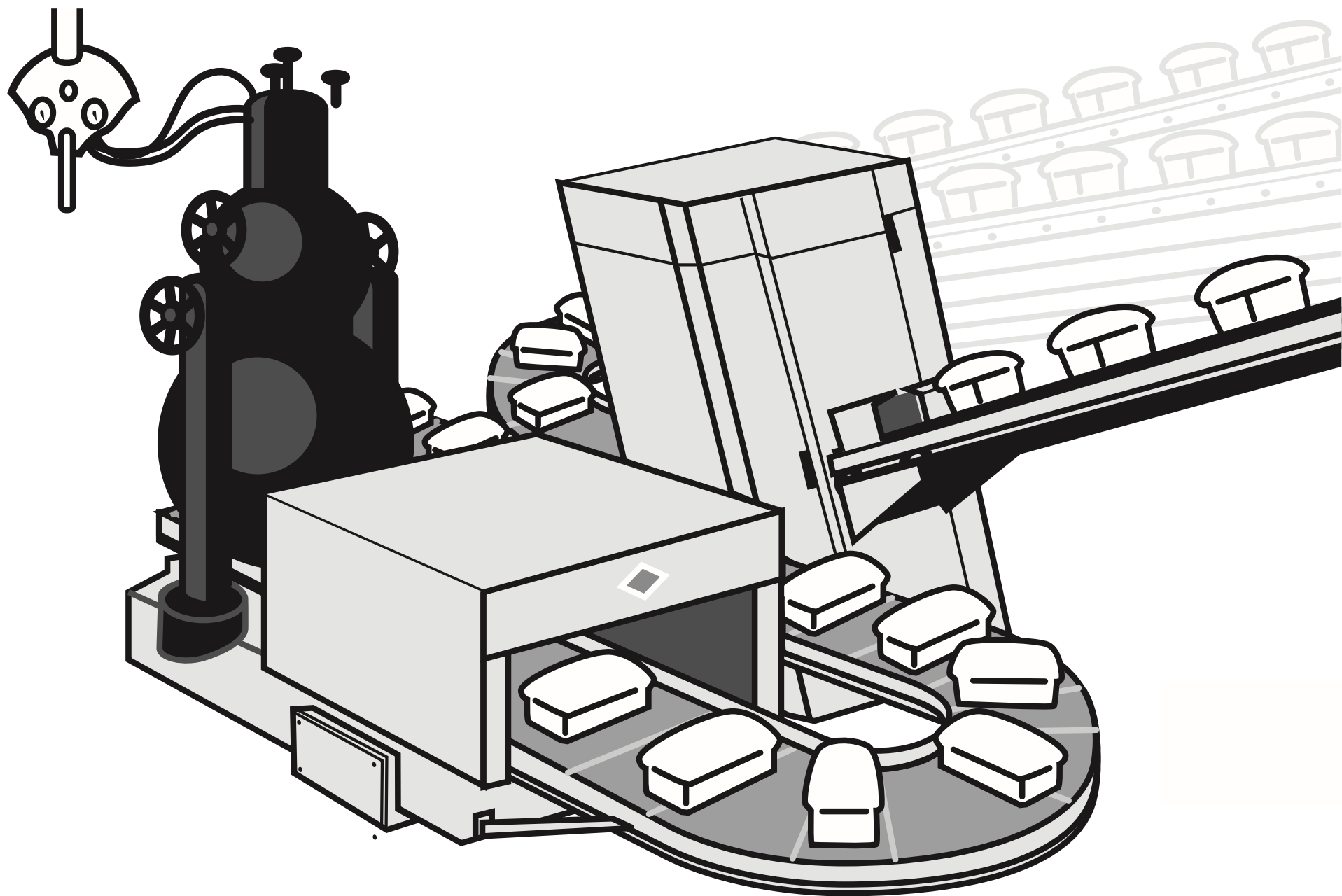

Can you imagine what this meant?
Can you comprehend the consequent?
The first time yet the world well fed!
And all because of Tom Smith's bread!

Not the last to see the repercussions
Were the Red Chinese, and, of course, the
Russians,
For Capitalist bread in such array

Threw the whole red block into black dis-
may!
Nonetheless, the world soon found
That bread was plentiful the world
around.
Thanks to Smith and all that bread,
A grateful world was at last well fed!

But isn't it a wondrous thing
How quickly fame is flown?
Smith, the hero of today
Tomorrow, scarcely known!
Yes, the fickle years passed by.
Smith was a billionaire.

But Smith himself was now forgot,
Though bread was everywhere.
People, asked from where it came,
Would very seldom know.

They would simply eat and ask,
'Was not it always so?'

However, Smith cared not a bit,
For millions ate his bread,
And "Everything is fine," thought he.
'I'm rich and they are fed!'

Everything was fine, he thought?
He reckoned not with fate.
Note the sequence of events
Starting on the date
On which inflation took its toll,
And to a slight extent,
The price on every loaf increased:
It went to one full cent!

A sharp reaction quickly came.
People were concerned.
White House aide expressed dismay.
Then the nation learned
That Russia lodged a sharp protest.
India did the same.
"Exploitation of the Poor!"
Yet, who was there to blame?

And though the clamor ebbed and flowed,
All that Tom would say
Was that it was but foolish talk.
Which soon would die away.
And it appeared that he was right.
Though on and on it ran,
The argument went 'round and 'round
But stopped where it began.

There it stopped, and people cried,
"For heaven's sake, we can't decide!
It's relative! Beyond dispute,
There's no such thing as 'absolute'!
And though we try with all our might,
Since nothing's ever black or white,
All that we can finally say is
'Everything one shade of grey is!'
So people cried out, "Give us light!
We can't tell what's wrong from right!"

To comprehend confusion,
We seek wisdom at its source.
To whom, then did the people turn?
The Intellectuals, of course!

And what could be a better time
For them to take the lead,
Than at their International Conference
On Inhumanity and Greed.
For at this weighty conference,
Once each year we face
The moral conscience of the world—
Concentrated in one place.

At that mighty conference were
A thousand, more or less,
Of intellectuals and bureaucrats,
And those who write the press.
And from Yale and Harvard
The professors; all aware
The fate of Smith would now be known.
Excitement filled the air!

"The time has come," the chairman said
"To speak of many things:
Of duty, bread and selfishness,
And the evil that it brings.
For, speaking thus we can amend
That irony of fate
That gives to unenlightened minds
The power to create.



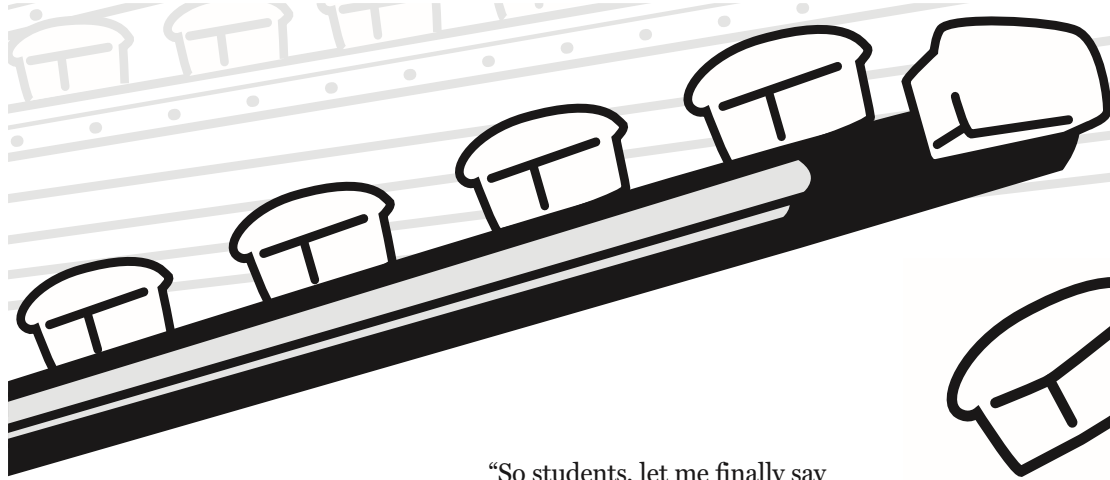

“Since reason tells us that it can’t,
Therefore let us start
Not by thinking with the mind,
But only with the heart!
Since we believe in people, then,”
At last the chairman said,
“We must meet our obligation
To see that they are fed!”

And so it went, one by one,
Denouncing private greed;
Denouncing those who’d profit thus
From other people’s need!

Then, suddenly each breath was held,
For there was none more wise
Than the nation’s foremost Pundit
Who now rose to summarize:

“My friends,” he said, (they all
exhaled)
“We see in these events
The flouting of the Higher Law—
And its consequence.
We must again remind ourselves
Just why mankind is cursed:
Because we fail to realize
Society comes first!”

“Smith placed himself above the
group
To profit from his brothers.
He failed to see the Greater Good,
Is Service, friends, to Others!”

With boldness and with vision,
then,
They ratified the motion
To dedicate to all mankind
Smith’s bread—and their devotion!

The conference finally ended.
It had been a huge success.
The intellectuals had spoken.
Now others did the rest.

The professors joined in all the
fuss,
And one was heard to lecture thus:
(For clarity, he spoke in terms
Of Mother Nature, birds and worms):

“That early birds should get the worm
Is clearly quite unfair.
Wouldn’t it much nicer be
If all of them would share?
But selfishness and private greed

Seem part of nature’s plan,
Which Mother Nature has decreed
For bird. But also Man?
The system which I question now,
As you are well aware,
(I’m sure you’ve heard the term
before
Is Business, Laissez-Faire!

“So students, let me finally say
That we must find a nobler way.
So, let us fix the race that all
May finish side-by-side;
The playing field forever flat,
The score forever tied.
To achieve this end, of course,
We turn to government—and force.
So, if we have to bring Smith do
As indeed we should,
I’m sure you will agree with me,
It’s for the Greater Good!”

Comments in the nation’s press
Now scorned Smith and his plunder:
“What right had he to get so rich
On other people’s hunger?”
A prize cartoon depicted Smith
With fat and drooping jowls
Snatching bread from hungry babes,
Indifferent to their howls.

One night, a TV star cried out,
“Forgive me if I stumble,
But I don’t think, I kid you not,
That Smith is very humble!”
Growing bolder, he leaped up,

(Silencing the cheers)
“Humility!” he cried to all—
And then collapsed in tears!

The clamor rises all about;
Now hear the politician shout:
“What’s Smith done, so rich to be?
Why should Smith have more than thee?
So, down with Smith and all his greed;
I’ll protect your right to need!”

Then Tom found to his dismay
That certain businessmen would say,
“The people now should realize
It’s time to cut Smith down to size,
For he’s betrayed his public trust
(And taken all that bread from us!)”

Well, since the Public does come first,
It could not be denied
That in matters such as this,
The public must decide.
So, SEC became concerned,
And told the press what it had learned:
“It’s obvious that he’s guilty
—Of what we’re not aware—
Though actually and factually
We’re sure there’s something there!”

And Antitrust now took a hand.
Of course it was appalled
At what it found was going on.
The “bread trust” it was called.

“Smith has too much crust,”
they said. “A deplorable condition
That Robber Barons profit thus
From cutthroat competition!”

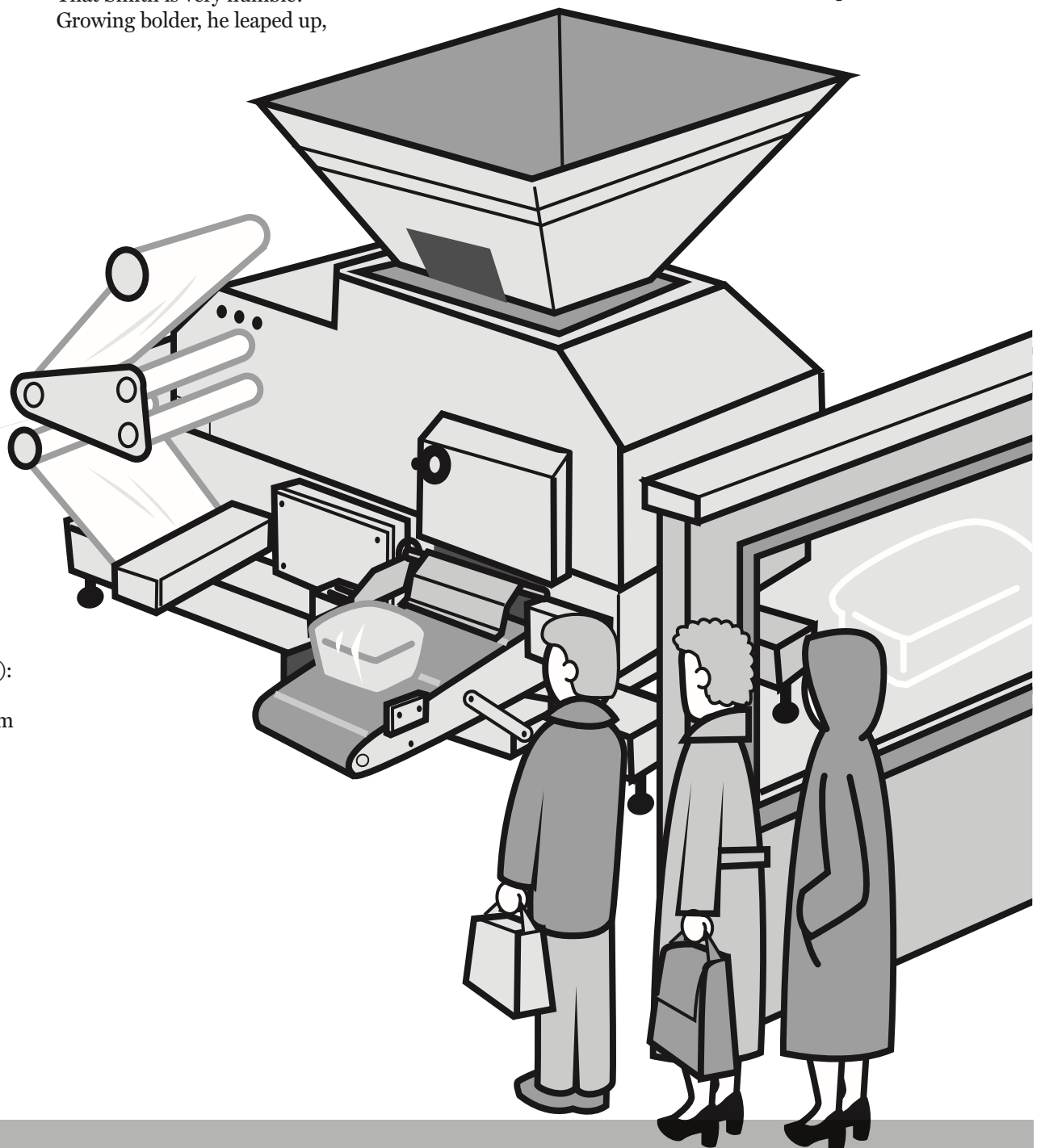

WELL!

This was getting serious!
So Smith felt that he must
Have a friendly interview
With SEC and 'Trust.
So, hat in hand, he went to them.
They'd surely been misled;
No rule of law had he defied.
But then their lawyer said:

"The rule of law, in complex times,
Has proved itself deficient.
We much prefer the rule of men.
It's vastly more efficient.

"So, nutshell-wise, the way it is,
The law is what we say it is!

"So, let me state the present rules,"
The lawyer then went on,
"These very simple guidelines
You can rely upon:
You're gouging on your prices
If you charge more than the rest.
But it's unfair competition
If you think you can charge less!
"A second point that we would make,
To help avoid confusion:
Don't try to charge the same amount,
For that would be collusion!

"You must compete—but not too much.
For if you do, you see,
Then the market would be yours—
And that's monopoly!
Oh, don't dare monopolize!
We'd raise an awful fuss,
For that's the greatest crime of all!
(Unless it's done by us!)"

"I think I understand," said Tom.
"And yet, before I go,
How does one get a job like yours?
I'd really like to know!"

The lawyer rose then with a smile;
"I'm glad you asked," said he.
"I'll tell you how I got my start
And how it came to be."

(His secretaries gathered 'round
As their boss did thus expound.)

*"When I was a lad going off to school,
I was always guided by this golden rule:
Let others take the lead in things, for
heaven's sake,
So if things go wrong-why, then it's their
mistake!"*
(*So if things go wrong-why, then it's their
mistake!*)

*"Following this precept it came to pass
I became the president of my senior class.
Then on to college where my profs extolled
The very same theory from the very same
mold!"*
(*The very same theory from the very same
mold!*)

*"Let others take the chances, and I would
go along.
Then I would let them know where they all
went wrong!
So successful was my system that then
indeed,
I was voted most likely in my class to suc-
ceed!"*

*(He was voted most likely in his class to
succeed!)*

*"Then out into the world I went, along
with all the rest,
Where I put my golden rule to the ulti-
mate test.
I avoided all of commerce at whatever the
cost—
And because I never ventured, then I also
never lost!"*
(*And because he never ventured, then he
also never lost!*)

*"With this unblemished record then, I
quickly caught the eye
Of some influential people 'mongst the
powers on high.*

*And so these many years among the
mighty I have sat,
Having found my niche as a bureaucrat!"*
(*Having found his niche as a bureaucrat*)

*"To be a merchant prince has never been
my goal,
For I'm qualified to play a more impor-
tant role:
Since I've never failed in business, this of
course assures
That I'm qualified beyond dispute to now
run yours!"*
(*That he's qualified beyond dispute to now
run yours!*)

"Thanks; that clears it up," said Tom.

The lawyer said, "I'm glad!
We try to serve the public good.
We're really not so bad!"

"Now, in disposing of this case,
If you wish to know just how,
Go up to the seventh floor;
We're finalizing now!"

So, Tom went to the conference room
Up on the seventh floor.
He raised his hand, about to knock,
He raised it—but no more—
For what he overheard within
Kept him outside the door!
A sentence here, a sentence there—
Every other word—
He couldn't make it out (he hoped),
For this is what he heard:

"Mumble, mumble, let's not fumble!
Mumble, mumble, what's the charge?
Grumble, grumble, he's not humble?
Private greed? Or good of all?"

"Public Interest, Rah! Rah! Rah!
Business, Business, Bah! Bah! Bah!"

"Say, now this now we confess
That now this now is a mess!
Well now, what now do we guess?
Discharge? Which charge would be best?"

"How 'bout 'Greed and Selfishness'?
Oh, wouldn't that be fun?
It's vague enough to trip him up
No matter what he's done!"

"We don't produce or build a thing!
But before we're through,
We allow that now we'll show Smith how
We handle those who do!"

"We serve the public interest;
We make up our own laws;
Oh, golly gee, how selflessly
We serve the public cause!"

"For we're the ones who make the rules
At 'Trust and SEC,
So bye and bye we'll get that guy;
Now, what charge will it be?"

"Price too high? Or price too low?
Now, which charge will we make?
Well, we're not loath to charging both
When public good's at stake!"

"But can we go one better?
How 'bout monopoly?
No muss, no fuss, oh clever us!
Right-O! Let's charge all three!"

"But why stop here? We have one more!
Insider Trading! Number four!
We've not troubled to define
This crime in any way so,
This allows the courts to find
Him guilty 'cause we say so!"

So, that was the indictment.
Smith's trial soon began.
It was a cause célèbre
Which was followed' cross the land.
In his defense Tom only said,
"I'm rich, but all of you are fed!
Is that bargain so unjust
That I should now be punished thus?"

Tom fought it hard all the way.
But it didn't help him win.
The jury took but half an hour
To bring this verdict in:

"Guilty! Guilty! We agree!
He's guilty of this plunder!
He had no right to get so rich
On other people's hunger!"

"Five years in jail!" the judge then said.
"You're lucky it's not worse!
Robber Barons must be taught
Society Comes First!
As flies to wanton boys," he leered,
"Are we to men like these!
They exploit us for their sport!
Exploit us as they please!"

The sentence seemed a bit severe,
But mercy was extended.
In deference to his mother's pleas,
One year was suspended.
And what about the Bread Machine?
Tom Smith's little friend?
Broken up and sold for scrap.
Some win. Some lose. The end.

EPILOGUE

Now, bread is baked by government.
And as might be expected,
Everything is well controlled—
The public well protected.

True, loaves cost ten dollars each.
But our leaders do their best.
The selling price is half a cent.
Taxes pay the rest!

