

PASCO COUNTY LEGAL NOTICES

**FIRST INSERTION**

**NOTICE OF SALE**  
Public Storage, Inc.  
PS Orangeco Inc.

Personal property consisting of sofas, TV's, clothes, boxes, household goods and other personal property used in home, office or garage will be sold or otherwise disposed of at public sales on the dates & times indicated below to satisfy Owners Lien for rent & fees due in accordance with Florida Statutes: Self-Storage Act, Sections 83.806 & 83.807. All items or spaces may not be available for sale. Cash or Credit cards only for all purchases & tax resale certificates required, if applicable.

Public Storage 25817  
6647 Embassy Blvd.  
Port Richey, FL 34668  
Thursday April 24, 2014 9:00AM  
A0003 Stephanie Osorio  
D0007 Jerry Tate  
E1177 Cherise Eames  
E2262 Sean Mundus  
E2333 Patrick Carmichael  
E2344 Jonathan Card

Public Storage 25808  
7139 Mitchell Blvd.  
New Port Richey, FL 34655  
Thursday April 24, 2014 9:30AM  
1720 Luiz Fernando Malta

Public Storage 25436  
6609 State Rd 54  
New Port Richey, FL 34653  
Thursday April 24, 2014 10:00AM  
2004 Alejandra Melo  
2487 Bennet Brooks  
3072 Alicia Mccoy  
3173 James Baker  
3183 Sherry Harrison  
3522 Rickey Sims  
4231 Sheila Taylor  
4237 Robert Trego, Jr. R  
4704 Scott Devault  
April 4, 11, 2014 14-01992P

**FIRST INSERTION**

**NOTICE OF PUBLIC SALE**  
U-Stor Zephyrhills, Castle Keep, Ridge and United Pasco Self Storage will be held on or thereafter the dates in 2014 and times indicated below, at the locations listed below, to satisfy the self storage lien. Units contain general household goods. All sales are final. Management reserves the right to withdraw any unit from the sale or refuse any offer of bid. Payment by CASH ONLY, unless otherwise arranged!

U-Stor,(Zephyrhills)36654 SR 54, Zephyrhills, FL 33541 on Wednesday April 23, 2014 @ 2:00pm.  
Jonathan Weaver A44  
Connie Rogers A66

U-Stor, (Castle Keep) 17326 US Hwy. 19 North, Hudson, FL 34667 on Tuesday, April 29, 2014 @ 2:00 pm.  
Robert Milne H28  
Bryan Nawicki H31  
Penny Rauhuff E1  
Stephen Peszel E21  
Jacqueline Shannon I201  
Katrina Schaefer I311

U-Stor, (United -Pasco) 11214 US Hwy 19 North, Port Richey, FL 34668 on Wednesday, April 23, 2014 @9:30 am.  
Thomas Barnes B457  
Jvuan D. King B1  
Melanie Cruz B311  
Sharon Morales B352  
Jason R Castle B66

U-Stor, (Ridge) 7215 Ridge Rd. Port Richey, FL 34668 on Wednesday, April 23, 2014 @ 10:00 am.  
John Bridgeman C291  
Norberto Escibano E100  
Pamela Croney E52  
Kelly Keyser F201  
Juan Morales F301  
Margarita Pacheco De Lizardo F323  
April 4, 11, 2014 14-02011P

**FIRST INSERTION**

**NOTICE UNDER FICTITIOUS NAME LAW PURSUANT TO SECTION 865.09, FLORIDA STATUTES**

NOTICE IS HEREBY GIVEN that the undersigned, desiring to engage in business under the fictitious name of River Coast Fence Company located at 1152 Chancellor Dr., in the County of Pasco, in the City of Holiday, Florida 34690 intends to register the said name with the Division of Corporations of the Florida Department of State, Tallahassee, Florida. Dated at Holiday, Florida, this 28 day of 03, 2014.  
Cliff Robbins/Carol Amanda Rao  
April 4, 2014 14-01973P

**FIRST INSERTION**

**NOTICE OF PUBLIC SALE OF ABANDONED VESSEL**

A public auction will take place at Darlington Boat & RV Storage, LLC 3210 Darlington Rd, Holiday, FL 34691, Monday April 14th, 2014 at 11:00a.m.

The following property will be sold:

FX Yamaha Cruiser Output-YAMA 4129L506-FL0709SJ  
FX Yamaha Cruiser High Output-YAMA 1564C606-FL087ONE  
Trailer Model PWDV-D885YS

The property being sold was owned or held on behalf of:  
Robert Mark Cerrito

The sale will be held to satisfy the lien for charges in the amount of \$1547.58. Plus the cost of advertising and the expense of the sale.

The inventory is on file in the office : Darlington Boat & RV Storage, LLC located at 3210 Darlington Rd, Holiday and may be inspected during business hours prior to the date of sale.

The terms of sale are cash in lawful money of the United States, with sale going to the highest bidder in competitive bidding. The property must be paid for and removed by the purchaser at the time of sale.

Dated 3/25/14

DARLINGTON BOAT & RV STORAGE, LLC  
3210 Darlington Rd  
Holiday, FL 34691  
George Mastrovasilis  
727-485-5690  
April 4, 11, 2014 14-01936P

**FIRST INSERTION**

**NOTICE TO CREDITORS IN THE CIRCUIT COURT OF THE SIXTH JUDICIAL CIRCUIT IN AND FOR PASCO COUNTY, FLORIDA PROBATE DIVISION CASE NO. 2014-CP-000320-CPAX-WS**

**IN RE: THE ESTATE OF RICHARD ALLEN LAUGEL, a/k/a RICHARD A. LAUGEL, a/k/a RIC LAUGEL, Deceased.**

The administration of the estate of RICHARD ALLEN LAUGEL, a/k/a RICHARD A. LAUGEL, a/k/a RIC LAUGEL, deceased, whose date of death was January 22, 2014; Case Number 2014-CP-000320-CPAX-WS, is pending in the Circuit Court for Pasco County, Florida, Probate Division, the address of which is 7530 Little Road, Port Richey, Florida 34654. The name and address of the personal representative and the personal representative's attorney are set forth below.

All creditors of the decedent and other persons having claims or demands against decedent's estate, including un-matured, contingent or unliquidated claims, on whom a copy of this notice is served must file their claims with this court WITHIN THE LATER OF 3 MONTHS AFTER THE DATE OF THE FIRST PUBLICATION OF THIS NOTICE OR 30 DAYS AFTER THE DATE OF SERVICE OF A COPY OF THIS NOTICE ON THEM.

All other creditors of the decedent and other persons having claims or demands against decedent's estate, including un-matured, contingent or unliquidated claims, must file their claims with this court WITHIN 3 MONTHS AFTER THE DATE OF THE FIRST PUBLICATION OF THIS NOTICE.

ALL CLAIMS NOT SO FILED WILL BE FOREVER BARRED.

NOTWITHSTANDING THE TIME PERIODS SET FORTH ABOVE, ANY CLAIM FILED TWO (2) YEARS OR MORE AFTER THE DECEDENT'S DATE OF DEATH IS BARRED.

The date of first publication of this Notice is the 4th day of April 2014.

**Personal Representative:**  
**Amy Amelia Laugel**  
1015 Orca Court  
Holiday, Florida 34691  
Attorney for Personal Representative:  
James E. Royal, Esquire  
Law Offices of Thomas J. Donnelly  
1172 Brownell Street  
Clearwater, Florida 33756  
(727) 461-4955  
SPN: 115577 | FBN: 0022899  
Service Email:  
service@thomasjdonnelly.com  
April 4, 11, 2014 14-01985P

**FIRST INSERTION**

**NOTICE TO CREDITORS IN THE CIRCUIT COURT FOR PASCO COUNTY, FLORIDA PROBATE DIVISION File No. 512014CP000221CPAXWS**

**Division J**  
**IN RE: ESTATE OF WILLIAM G. HENRIKSEN Deceased.**

The administration of the estate of William G. Henriksen, deceased, whose date of death was September 17, 2013, is pending in the Circuit Court for Pasco County, Florida, Probate Division, the address of which is 7530 Little Road, New Port Richey, FL 34654. The names and addresses of the personal representative and the personal representative's attorney are set forth below.

All creditors of the decedent and other persons having claims or demands against decedent's estate on whom a copy of this notice is required to be served must file their claims with this court WITHIN THE LATER OF 3 MONTHS AFTER THE TIME OF THE FIRST PUBLICATION OF THIS NOTICE OR 30 DAYS AFTER THE DATE OF SERVICE OF A COPY OF THIS NOTICE ON THEM.

All other creditors of the decedent and other persons having claims or demands against decedent's estate must file their claims with this court WITHIN 3 MONTHS AFTER THE DATE OF THE FIRST PUBLICATION OF THIS NOTICE.

ALL CLAIMS NOT FILED WITHIN THE TIME PERIODS SET FORTH IN SECTION 733.702 OF THE FLORIDA PROBATE CODE WILL BE FOREVER BARRED.

NOTWITHSTANDING THE TIME PERIODS SET FORTH ABOVE, ANY CLAIM FILED TWO (2) YEARS OR MORE AFTER THE DECEDENT'S DATE OF DEATH IS BARRED.

The date of first publication of this notice is April 4, 2014.

**Personal Representative:**  
**Robert Henriksen**  
2077 Pine Street  
Baldwin, New York 11510  
Attorney for Personal Representative:  
William Rambaum  
Attorney for Robert Henriksen  
Florida Bar Number: 0297682  
28960 U.S. Hwy 19 North  
Suite 100  
Clearwater, FL 33761  
Telephone: (727) 781-5357  
Fax: (727) 781-1387  
E-Mail:  
brambaum@rambaumlaw.com  
Alt E-Mail: jherny@rambaumlaw.com  
April 4, 11, 2014 14-02012P

**FIRST INSERTION**

**NOTICE OF FORECLOSURE SALE IN THE CIRCUIT COURT IN AND FOR PASCO COUNTY, FLORIDA CASE NO: 2012-CA-000418-WS**

**BANK OF AMERICA, N.A., SUCCESSOR BY MERGER TO BAC HOME LOANS SERVICING, LP FKA COUNTRYWIDE HOME LOANS SERVICING LP**

**Plaintiff, vs.**  
**CHARLES R. COOPER, et al. Defendants.**

NOTICE is hereby given that the Clerk of the Circuit Court of Pasco County, Florida, will on the 17th day of April, 2014, at 11:00AM online at www.pasco.realforeclose.com, in accordance with Chapter 45 Florida Statutes, offer for sale and sell at public outcry to the highest and best bidder for cash, the following-described property situate in Pasco County, Florida:

LOT 7, LESS THE NORTH 55 FEET, BLOCK 2, EICHOLTZ SUBDIVISION, ACCORDING TO THE MAP OR PLAT THEREOF RECORDED IN PLAT BOOK 5, PAGE 18, PUBLIC RECORDS OF PASCO COUNTY, FLORIDA.

pursuant to the Final Judgment entered in a case pending in said Court, the style of which is indicated above.

Any person or entity claiming an interest in the surplus, if any, resulting from the foreclosure sale, other than the property owner as of the date of the Lis Pendens, must file a claim on same with the Clerk of Court within 60 days after the foreclosure sale.

AMERICANS WITH DISABILITIES ACT. If you are a person with a disability who needs any accommodation in order to participate in this proceeding, you are entitled, at no cost to you, to the provision of certain assistance. Please contact the Human Rights Office, 400 S. Ft. Harrison Ave., Ste. 500 Clearwater, FL 33756, (727) 464-4880(V) at least 7 days before your scheduled court appearance, or immediately upon receiving this notification if the time before the scheduled appearance is less than 7 days; if you are hearing impaired call 711.

DATED this 25 day of March, 2014 .  
Chris Bertels, Esquire  
Florida Bar No: 98267  
Jessica Leigh Saltz, Esquire  
Florida Bar No: 92019

BUTLER & HOSCH, P.A.  
3185 South Conway Road, Suite E  
Orlando, Florida 32812  
Telephone: (407) 381-5200  
Fax: (407) 381-5577  
js92019@butlerandhosch.com  
FLPleadings@butlerandhosch.com  
B&H # 333091  
April 4, 11, 2014 14-01929P

**FIRST INSERTION**

**NOTICE OF FORECLOSURE SALE IN THE CIRCUIT COURT OF THE 6TH JUDICIAL CIRCUIT, IN AND FOR PASCO COUNTY, FLORIDA CIVIL DIVISION CASE NO. 51-2011-CA-005225ES**

**NATIONSTAR MORTGAGE, LLC Plaintiff, vs. ALEXIS COLMENARES; ET AL; Defendants,**

NOTICE IS HEREBY GIVEN pursuant to a Final Judgment of Foreclosure dated March 12, 2014, and entered in Case No. 51-2011-CA-005225ES, of the Circuit Court of the 6th Judicial Circuit in and for Pasco County, Florida, wherein NATIONSTAR MORTGAGE, LLC is Plaintiff and ALEXIS COLMENARES; CRISTINA PEREZ; UNKNOWN PERSON(S) IN POSSESSION OF THE SUBJECT PROPERTY; are defendants. The Clerk of Court will sell to the highest and best bidder for cash BY ELECTRONIC SALE AT: WWW.PASCO.REALFORECLOSE.COM, at 11:00 A.M., on the 28 day of April, 2014, the following described property as set forth in said Final Judgment, to wit:

A PORTION OF THE TRACT 40, WILLIAMS ACRES, LYING SECTION 31, TOWNSHIP 25 SOUTH, RANGE 20 EAST, PASCO COUNTY, FLORIDA, BEING MORE PARTICULARLY DESCRIBED AS FOLLOWS: BEGIN AT THE NORTHEAST CORNER OF STATED SECTION 31; THENCE NORTH 88 DEGREES 50 MINUTES 27 SECONDS WEST (ASSUMED BEARING) A DISTANCE OF 330.00 FEET; THENCE SOUTH 00 DEGREES 32 MINUTES 25 SECONDS WEST, A DISTANCE OF 3758.34 FEET; THENCE SOUTH 30 DEGREES 40 MINUTES 14 SECONDS WEST, A DISTANCE OF 309.47 FEET; THENCE NORTH 83 DEGREES 04 MINUTES 07 SECONDS WEST, A DISTANCE OF 1114.55 FEET; THENCE SOUTH 15 DEGREES 55 MINUTES 25 SECONDS WEST, A DISTANCE OF 429.46 FEET; THENCE SOUTH 77 DEGREES 35 MINUTES 08 SECONDS EAST, A DISTANCE OF 260.00 FEET, FOR A POINT OF BEGINNING; THENCE CONTINUE SOUTH 77 DEGREES 35 MINUTES 08 SECONDS EAST, A DISTANCE OF 224.97 FEET; THENCE SOUTH 15 DEGREES 17 MINUTES 25 SECONDS WEST, A DISTANCE OF 454.90 FEET, THENCE NORTH 74 DEGREES 42 MINUTES 35 SECONDS WEST, A DISTANCE OF 227.07 FEET; THENCE NORTH 15 DEGREES 35 MINUTES 56 SECONDS EAST, A DISTANCE OF 443.62 FEET TO THE POINT OF BEGINNING. LESS 30.00 FEET FOR ROAD RIGHT-OF-WAY ON THE SOUTHERLY BOUNDARY THEREOF AND 1/2 OF ANY AND ALL OIL, GAS AND MINERAL RIGHTS OF RECORD.

A person claiming an interest in the surplus from the sale, if any, other than the property owner as of the date of the lis pendens must file a claim within 60 days after the sale.

This notice is provided pursuant to Administrative Order 2010-045 PA/PI-CIR "If you are a person with disability who needs any accommodation in order to participate in this proceeding, you are entitled, at no cost to you the provision of certain assistance. Please contact Public Information Dept., Pasco County Government Center, 7530 Little Rd., New Port Richey, FL 34654; (727) 847-8110 (V) for proceedings in New Port Richey; (352) 521-4274, ext. 8110 (V) for proceedings in Dade City at least 7 days before your scheduled court appearance, or immediately upon receiving this notification if the time before the scheduled appearance is less than 7 days; if you are hearing or voice impaired, call 711."

Dated this 1 day of April, 2014.  
Eric M. Knopp, Esq.  
Bar. No.: 709921

Submitted by:  
Kahane & Associates, P.A.  
8201 Peters Road, Ste.3000  
Plantation, FL 33324  
Telephone: (954) 382-3486  
Telefacsimile: (954) 382-5380  
Designated service email:  
notice@kahaneandassociates.com  
File No.: 11-04185 NML  
April 4, 11, 2014 14-02020P

**FIRST INSERTION**

**NOTICE OF RESCHEDULED SALE IN THE CIRCUIT COURT OF THE SIXTH JUDICIAL CIRCUIT IN AND FOR PASCO COUNTY, FLORIDA CIVIL ACTION CASE NO.: 51-2008-CA-009747-CAAX-WS**

**COUNTRYWIDE HOME LOANS, INC., Plaintiff, vs. JAMES R. BYRNS, et al, Defendant(s).**

NOTICE IS HEREBY GIVEN Pursuant to an Order Rescheduling Foreclosure Sale dated on or about March 4, 2014, and entered in Case No. 51-2008-CA-009747-CAAX-WS of the Circuit Court of the Sixth Judicial Circuit in and for Pasco County, Florida in which Countrywide Home Loans, Inc., is the Plaintiff and James R. Byrns, are defendants, the Pasco County Clerk of the Circuit Court will sell to the highest and best bidder for cash in/on held online www.pasco.realforeclose.com: in Pasco County, Florida at 11:00AM on the 21st day of April, 2014, the following described property as set forth in said Final Judgment of Foreclosure:

COMMENCING AT THE NORTHEAST CORNER OF SECTION 2, TOWNSHIP 24 SOUTH, RANGE 17 EAST, PASCO COUNTY, FLORIDA; GO THENCE SOUTH 89°57'28" WEST, A DISTANCE OF 82.34 FEET; THENCE SOUTH 11°52'01" WEST, A DISTANCE OF 295.04 FEET; THENCE SOUTH 32°31'01" WEST, A DISTANCE OF 1929.46 FEET TO THE POINT OF BEGINNING; THENCE SOUTH 89°57'29" WEST, A DISTANCE OF 454.48 FEET TO A POINT OF A CURVE HAVING A CENTRAL ANGLE OF 42°05'28", A RADIUS OF 50.00 FEET, A TANGENT DISTANCE OF 19.24 FEET, A CHORD BEARING AND DISTANCE OF NORTH 21°05'15" WEST AND 35.91 FEET; THENCE ALONG SAID CURVE AN ARC

**FIRST INSERTION**

**NOTICE OF RESCHEDULED SALE IN THE CIRCUIT COURT OF THE SIXTH JUDICIAL CIRCUIT IN AND FOR PASCO COUNTY, FLORIDA CIVIL ACTION CASE NO.: 51-2008-CA-009747-CAAX-WS**

**COUNTRYWIDE HOME LOANS, INC., Plaintiff, vs. JAMES R. BYRNS, et al, Defendant(s).**

NOTICE IS HEREBY GIVEN Pursuant to an Order Rescheduling Foreclosure Sale dated on or about March 4, 2014, and entered in Case No. 51-2008-CA-009747-CAAX-WS of the Circuit Court of the Sixth Judicial Circuit in and for Pasco County, Florida in which Countrywide Home Loans, Inc., is the Plaintiff and James R. Byrns, are defendants, the Pasco County Clerk of the Circuit Court will sell to the highest and best bidder for cash in/on held online www.pasco.realforeclose.com: in Pasco County, Florida at 11:00AM on the 21st day of April, 2014, the following described property as set forth in said Final Judgment of Foreclosure:

COMMENCING AT THE NORTHEAST CORNER OF SECTION 2, TOWNSHIP 24 SOUTH, RANGE 17 EAST, PASCO COUNTY, FLORIDA; GO THENCE SOUTH 89°57'28" WEST, A DISTANCE OF 82.34 FEET; THENCE SOUTH 11°52'01" WEST, A DISTANCE OF 295.04 FEET; THENCE SOUTH 32°31'01" WEST, A DISTANCE OF 1929.46 FEET TO THE POINT OF BEGINNING; THENCE SOUTH 89°57'29" WEST, A DISTANCE OF 454.48 FEET TO A POINT OF A CURVE HAVING A CENTRAL ANGLE OF 42°05'28", A RADIUS OF 50.00 FEET, A TANGENT DISTANCE OF 19.24 FEET, A CHORD BEARING AND DISTANCE OF NORTH 21°05'15" WEST AND 35.91 FEET; THENCE ALONG SAID CURVE AN ARC

**FIRST INSERTION**

**DISTANCE OF 36.73 FEET; THENCE NORTH 47°52'01" EAST A DISTANCE OF 621.28 FEET; THENCE NORTH 89°57'29" EAST A DISTANCE OF 293.66 FEET; THENCE SOUTH 32°31'00" WEST A DISTANCE OF 533.89 FEET TO THE POINT OF BEGINNING.**

A/K/A 14651 DUANE COURT, SPRING HILL, FL 34610

Any person claiming an interest in the surplus from the sale, if any, other than the property owner as of the date of the Lis Pendens must file a claim within 60 days after the sale.

If you are a person with a disability who needs an accommodation in order to participate in this proceeding, you are entitled, at no cost to you, to the provision of certain assistance. Please contact:

Public Information Dept., Pasco County Government Center 7530 Little Rd. New Port Richey, FL 34654 Phone: 727.847.8110 (voice) in New Port Richey 352.521.4274, ext 8110 (voice) in Dade City Or 711 for the hearing impaired

Contact should be initiated at least seven days before the scheduled court appearance, or immediately upon receiving this notification if the time before the scheduled appearance is less than seven days.

The court does not provide transportation and cannot accommodate such requests. Persons with disabilities needing transportation to court should contact their local public transportation providers for information regarding transportation services.

Dated in Hillsborough County, Florida on this 27th day of March, 2014.  
/s/ Erik Del'Etoile  
Erik Del'Etoile, Esq.  
FL Bar # 71675

Albertelli Law  
Attorney for Plaintiff  
P.O. Box 23028  
Tampa, FL 33623  
(813) 221-4743  
(813) 221-9171 facsimile  
eService:  
servealaw@albertellilaw.com  
BM - 10-44393  
April 4, 11, 2014 14-01947P

**FIRST INSERTION**

**NOTICE OF SALE IN THE CIRCUIT COURT OF THE SIXTH JUDICIAL CIRCUIT OF THE STATE OF FLORIDA, IN AND FOR PASCO COUNTY CIVIL DIVISION CASE NO. 51-2013-CA-000499-XXXX-WS**

**DEUTSCHE BANK NATIONAL TRUST COMPANY, AS TRUSTEE FOR LONG BEACH MORTGAGE LOAN TRUST 2006-5, Plaintiff, vs. JOSEPH KING; UNKNOWN SPOUSE OF JOSEPH KING; HEATHER KING A/K/A HEATHER M. KING; UNKNOWN SPOUSE OF HEATHER KING A/K/AHEATHER M. KING; JOHN LINDQUIT; CHRISTINA DEEB; IF LIVING, INCLUDING ANY UNKNOWN SPOUSE OF SAID DEFENDANT(S), IF REMARRIED, AND IF DECEASED, THE RESPECTIVE UNKNOWN HEIRS, DEVISEES, GRANTEE, ASSIGNEES, CREDITORS, LIENORS, AND TRUSTEES, AND ALL OTHER PERSONS CLAIMING BY, THROUGH, UNDER OR AGAINST THE NAMED DEFENDANT(S); JPMORGAN CHASE BANK, NATIONAL ASSOCIATION, SUCCESSOR IN INTEREST BY PURCHASE FROM THE FDIC AS RECEIVER OF WASHINGTON MUTUAL BANK SUCCESSOR IN INTEREST TO LONG BEACH MORTGAGE COMPANY; STATE OF FLORIDA; CLERK OF THE CIRCUIT COURT OF PASCO COUNTY; STATE OF FLORIDA DEPARTMENT OF REVENUE; WHETHER DISSOLVED OR PRESENTLY EXISTING, TOGETHER WITH ANY GRANTEE, ASSIGNEES, CREDITORS, LIENORS, OR TRUSTEES OF SAID DEFENDANT(S) AND ALL OTHER PERSONS CLAIMING BY, THROUGH, UNDER, OR AGAINST DEFENDANT(S); UNKNOWN TENANT #1; UNKNOWN TENANT #2; Defendant(s)**

Notice is hereby given that, pursuant

**FIRST INSERTION**

to a Final Summary Judgment of Foreclosure entered on 03/05/2014 in the above-styled cause, in the Circuit Court of Pasco County, Florida, the office of Paula S. O'Neil clerk of the circuit court will sell the property situate in Pasco County, Florida, described as:

LOT 351, GULF HIGHLANDS UNIT TWO, ACCORDING TO THE MAP OR PLAT THEREOF, RECORDED IN PLAT BOOK 11, PAGES 11, PAGES 127 THROUGH 129 INCLUSIVE, OF THE PUBLIC RECORDS OF PASCO COUNTY, FLORIDA.

at public sale, to the highest and best bidder, for cash, www.pasco.realforeclose.com at 11:00 o'clock, A.M, on April 21, 2014

Any person claiming an interest in the surplus from the sale, if any, other than the property owner as of the date of the lis pendens, must file a claim within 60 days after the sale.

If you are a person with a disability who needs any accommodation in order to participate in this proceeding, you are entitled, at no cost to you, to the provision of certain assistance. Please contact the Public Information Dept., Pasco County Government Center, 7530 Little Rd., New Port Richey, FL 34654; (727) 847-8110 (V) for proceedings in New Port Richey; (352) 521-4274, ext. 8110 (V) for proceedings in Dade City, at least 7 days before your scheduled court appearance, or immediately upon receiving this notification if the time before the scheduled appearance is less than 7 days; if you are hearing impaired call 711.

Date: 03/31/2014  
ATTORNEY FOR PLAINTIFF  
By /s/ Josh D. Donnelly  
Josh D. Donnelly  
Florida Bar #64788

THIS INSTRUMENT PREPARED BY:  
Law Offices of Daniel C. Consuegra  
9204 King Palm Drive  
Tampa, FL 33619-1328  
Phone: 813-915-8660  
Attorneys for Plaintiff  
130226-T  
April 4, 11, 2014 14-02001P

## FIRST INSERTION

NOTICE OF JUDICIAL SALE BY THE CLERK IN THE CIRCUIT COURT FOR THE SIXTH JUDICIAL CIRCUIT IN AND FOR PASCO COUNTY, FLORIDA CASE NO.: 51 2013 CA - 1461 WS U.S. BANK NATIONAL ASSOCIATION, SUCCESSOR IN INTEREST TO BANK OF AMERICA, NATIONAL ASSOCIATION, SUCCESSOR BY MERGER TO LASALLE BANK NATIONAL ASSOCIATION, AS TRUSTEE FOR THE REGISTERED HOLDERS OF BEAR STEARNS COMMERCIAL MORTGAGE SECURITIES II INC., COMMERCIAL MORTGAGE PASS-THROUGH CERTIFICATES, SERIES 2005-PWR10 Plaintiff, vs. EMBASSY RETAIL, LLC, a Delaware limited liability company, Defendant.

IN THE CIRCUIT COURT OF THE SIXTH JUDICIAL CIRCUIT IN AND FOR PASCO COUNTY, FLORIDA, CIVIL ACTION NO: 2013 CA - 1461 WS; U.S. BANK NATIONAL ASSOCIATION, SUCCESSOR IN INTEREST TO BANK OF AMERICA, NATIONAL ASSOCIATION, SUCCESSOR BY MERGER TO LASALLE BANK NATIONAL ASSOCIATION, AS TRUSTEE FOR THE REGISTERED HOLDERS OF BEAR STEARNS COMMERCIAL MORTGAGE SECURITIES II INC., COMMERCIAL MORTGAGE PASS-THROUGH CERTIFICATES, SERIES 2005-PWR10, PLAINTIFF AND EMBASSY RETAIL, LLC DEFENDANT

NOTICE IS HEREBY GIVEN that pursuant to an Final Judgment entered in the above styled cause now pending in said court that I will sell to the highest and best bidder for cash the following described real and other property in Pasco County, Florida, in accordance with section 45.031, Florida Statutes by electronic sale beginning at 11:00 a.m. on May 8, 2014 at www.pasco.realeforeclose.com.

DESCRIPTION of real and other property attached hereto as Exhibit A

## Exhibit A

THE LAND REFERRED TO HEREIN BELOW IS SITUATED IN THE COUNTY OF PASCO, STATE OF FLORIDA, AND IS DESCRIBED AS FOLLOWS:

PARCEL 1  
A TRACT OF LAND LAND LYING IN THE NORTHEAST QUARTER OF SECTION 21, TOWNSHIP 25 SOUTH, RANGE 16 EAST, PASCO COUNTY, FLORIDA, MORE PARTICULARLY DESCRIBED AS FOLLOWS:

COMMENCE AT THE SOUTHEAST CORNER OF THE SOUTHWEST ¼ OF THE NORTHEAST ¼ OF SECTION 21, TOWNSHIP 25 SOUTH, RANGE 16 EAST, PASCO COUNTY, FLORIDA; THENCE ALONG THE NORTH BOUNDARY LINE OF TRACT "D" AS CONTAINED IN EMBASSY HILLS UNIT 1, SHOWN ON PLAT RECORDED IN PLAT BOOK 11, PAGE 86, 87 AND 88, OF THE PUBLIC RECORDS OF PASCO COUNTY, FLORIDA; SOUTH 89° 49' 51" EAST, A DISTANCE OF 29.06 FEET TO THE NORTHEAST LINE OF SAID TRACT "D"; THENCE ALONG THE EAST BOUNDARY LINE OF SAID TRACT "D", THE FOLLOWING COURSES AND DISTANCES; SOUTH 00° 20' 09" WEST, 85.14 FEET; NORTH 89° 17' 31" WEST, 14.95 FEET; SOUTH 00° 16' 59" WEST 377.52 FEET TO THE SOUTH BOUNDARY LINE OF SAID TRACT "D", SAID SOUTH BOUNDARY LINE ALSO BEING THE NORTH RIGHT-OF-WAY LINE OF EMBASSY BOULEVARD; THENCE ALONG THE SOUTH BOUNDARY LINE OF SAID TRACT "D", NORTH 89° 44' 06" WEST, A DISTANCE OF 274.87 FEET; THENCE NORTH 00° 17' 17" EAST, A DISTANCE OF 300.01 FEET; THENCE NORTH 89° 44' 33" WEST, A DISTANCE OF 455.01 FEET TO THE POINT OF BEGINNING OF THE LAND HEREAFTER DESCRIBED; THENCE SOUTH 00° 10' 26" EAST, A DISTANCE OF 299.97 FEET TO THE SOUTH BOUNDARY LINE OF SAID TRACT "D", SAID SOUTH BOUNDARY LINE ALSO BEING THE NORTH RIGHT-OF-WAY LINE OF EMBASSY

BOULEVARD; THENCE ALONG THE SOUTH BOUNDARY LINE, NORTH 89° 37' 25" WEST, A DISTANCE OF 49.95 FEET; THENCE NORTH 00° 09' 57" WEST, A DISTANCE OF 462.52 FEET TO THE NORTH BOUNDARY LINE OF SAID TRACT "D"; THENCE ALONG THE NORTH BOUNDARY LINE, NORTH 89° 42' 44" WEST, A DISTANCE OF 250.12 FEET TO THE EAST BOUNDARY LINE OF THE DONASA PARCEL AS DESCRIBED IN OFFICIAL RECORDS BOOK 1072, PAGE 519 AND 525, OF THE PUBLIC RECORDS OF PASCO COUNTY, FLORIDA; THENCE ALONG THE EAST BOUNDARY LINE OF SAID DONASA PARCEL, NORTH 00° 10' 03" WEST, A DISTANCE OF 278.22 FEET TO THE NORTHEAST CORNER OF SAID DONASA PARCEL; THENCE NORTH 89° 42' 35" WEST, A DISTANCE OF 426.07 FEET TO A POINT ON THE EASTERLY RIGHT-OF-WAY LINE OF STATE ROAD #55; THENCE ALONG SAID EASTERLY RIGHT-OF-WAY LINE NORTH 28° 41' 02" EAST, A DISTANCE OF 1153.24 FEET TO A LINE 20.00 FEET SOUTH OF AND PARALLEL WITH THE SOUTH BOUNDARY LINE OF SAID TRAILER HAVEN AS SHOWN ON THE PLAT RECORDED IN PLAT BOOK 5, PAGE 76 OF THE PUBLIC RECORDS OF PASCO COUNTY, FLORIDA; THENCE ALONG SAID LINE 20.00 FEET SOUTH OF AND PARALLEL WITH THE SOUTH BOUNDARY LINE OF SAID TRAILER HAVEN AND THE EASTERLY EXTENSION THEREOF, SOUTH 89° 39' 04" EAST, A DISTANCE OF 899.13 FEET TO THE EAST BOUNDARY LINE OF THE SOUTHWEST ¼ OF THE NORTHEAST ¼ OF SAID SECTION 21; THENCE ALONG THE EAST BOUNDARY LINE OF THE SOUTHWEST ¼ OF THE NORTHEAST ¼ OF SAID SECTION 21, SOUTH 00° 24' 34" WEST, A DISTANCE OF 42.65 FEET; THENCE ALONG THE EAST BOUNDARY LINE OF THE SOUTHWEST ¼ OF THE NORTHEAST ¼ OF SAID SECTION 21, SOUTH 00° 23' 01" WEST, A DISTANCE OF 573.90 FEET; THENCE LEAVING SAID EAST BOUNDARY LINE, SOUTH 29° 49' 00" WEST, A DISTANCE OF 195.43 FEET; THENCE SOUTH 35° 15' 30" WEST; A DISTANCE OF 285.00 FEET; THENCE SOUTH 48° 15' 30" WEST, A DISTANCE OF 275.00 FEET; THENCE NORTH 89° 44' 33" WEST, A DISTANCE OF 28.43 FEET; THENCE SOUTH 28° 40' 59" WEST, A DISTANCE OF 130.76 FEET; THENCE NORTH 89° 44' 35" WEST, A DISTANCE OF 163.46 FEET TO A POINT ON THE EAST BOUNDARY OF A 50.00 FOOT DRAINAGE EASEMENT AS RECORDED IN OFFICIAL RECORDS BOOK 1096, PAGE 330; THENCE ALONG SAID EAST BOUNDARY, SOUTH 00° 10' 26" EAST, A DISTANCE OF 135.00 FEET TO THE POINT OF THE BEGINNING.

PARCEL 2  
AN EASEMENT FOR THE PURPOSES OF INSTALLATION, CONSTRUCTION, OPERATION, USE, MAINTENANCE, REPAIR AND REPLACEMENT OF A RELATION FACILITY AS DESCRIBED IN AND PROVIDED FOR IN AN INSTRUMENT ENTITLED "DECLARATION OF EASEMENT", RECORDED OCTOBER 10, 1985, IN OFFICIAL RECORDS BOOK 1450, PAGE 393, OF THE PUBLIC RECORDS OF PASCO COUNTY, FLORIDA, UNDER, ABOVE AND ACROSS THE FOLLOWING DESCRIBED LAND:  
COMMENCE AT THE SOUTHEAST CORNER OF THE SOUTHWEST ¼ OF THE NORTHEAST ¼ OF SECTION 21, TOWNSHIP 25 SOUTH, RANGE 16 EAST, PASCO COUNTY, FLORIDA, FOR A POINT OF COMMENCEMENT; THENCE RUN ALONG THE NORTH BOUNDARY LINE OF TRACT "D" AS CON-

TAINED IN EMBASSY HILLS UNIT 1, SHOWN ON PLAT RECORDED IN PLAT BOOK 11, PAGES 86, 87, AND 88 OF THE PUBLIC RECORDS OF PASCO COUNTY, FLORIDA; SOUTH 89° 49' 50.7" EAST, A DISTANCE OF 29.06 FEET TO THE NORTHEAST LINE OF SAID TRACT "D"; THENCE ALONG THE EAST BOUNDARY LINE OF SAID TRACT "D", THE FOLLOWING COURSES AND DISTANCES; SOUTH 00° 20' 08.7" WEST, A DISTANCE OF 85.137 FEET; NORTH 89° 17' 30.7" WEST, A DISTANCE OF 14.945 FEET; SOUTH 00° 16' 59" WEST, A DISTANCE OF 377.522 FEET TO THE SOUTH BOUNDARY LINE OF SAID TRACT "D"; THENCE ALONG THE SOUTH BOUNDARY LINE OF SAID TRACT "D"; THENCE ALONG THE SOUTH BOUNDARY LINE OF SAID TRACT "D", NORTH 89° 44' 05.6" WEST, A DISTANCE OF 274.865 FEET; THENCE NORTH 00° 17' 17.3" EAST, A DISTANCE OF 300.01 FEET; THENCE NORTH 89° 44' 32.7" WEST, A DISTANCE OF 455.008 FEET; THENCE RUN NORTH 00° 10' 25.6" EAST, A DISTANCE OF 30.00 FEET TO THE POINT OF BEGINNING OF THE EASEMENT HEREAFTER DESCRIBED; THENCE CONTINUE NORTH 00° 10' 25.6" EAST, A DISTANCE OF 105.00 FEET; THENCE RUN SOUTH 89° 44' 33" EAST, A DISTANCE OF 163.46 FEET; THENCE RUN NORTH 28° 40' 59" EAST, A DISTANCE OF 130.76 FEET; THENCE RUN SOUTH 89° 44' 33" EAST, A DISTANCE OF 28.43 FEET; THENCE RUN NORTH 48° 15' 30" EAST, A DISTANCE OF 100.00 FEET; THENCE RUN SOUTH 00° 10' 25.6" WEST, A DISTANCE OF 286.91 FEET; THENCE RUN NORTH 89° 44' 32.7" WEST, A DISTANCE OF 328.72 FEET TO THE POINT OF BEGINNING.

## PARCEL 3

AN EASEMENT FOR TRAFFIC POLE AS PROVIDED FOR IN AN INSTRUMENT ENTITLED "RETENTION BASIN AGREEMENT" AS DISCLOSED BY THAT CERTAIN ACKNOWLEDGEMENT AND AGREEMENT RECORDED ON FEBRUARY 15, 2002, IN OFFICIAL RECORDS BOOK 4861, PAGE 1724, OF THE PUBLIC RECORDS OF PASCO COUNTY, FLORIDA, AFFECTING THE FOLLOWING DESCRIBED LAND:  
A PORTION OF TRACT-D EMBASSY HILLS UNIT ONE, AS SHOWN ON THE PLAT RECORDED IN PLAT BOOK 11, PAGES 86, 87, AND 88 OF THE PUBLIC RECORDS OF PASCO COUNTY, FLORIDA, BEING MORE PARTICULARLY DESCRIBED AS FOLLOWS:  
COMMENCE AT THE NORTHWEST CORNER OF TRACT-B, EMBASSY HILLS UNIT ONE, AS SHOWN ON THAT PLAT RECORDED IN PLAT BOOK 11, PAGES 86, 87 AND 88 OF THE PUBLIC RECORDS OF PASCO COUNTY, FLORIDA, FOR A POINT OF REFERENCE; THENCE ALONG THE SOUTHERLY RIGHT-OF-WAY LINE OF EMBASSY BOULEVARD AS SHOWN ON SAID PLAT OF EMBASSY HILLS UNIT ONE, ALSO BEING THE NORTHERLY BOUNDARY OF SAID TRACT-B SOUTH 89° 44' 30" EAST, FOR 352.00 FEET; THENCE PERPENDICULAR TO SAID SOUTHERLY RIGHT-OF-WAY LINE OF EMBASSY BOULEVARD, NORTH 00° 15' 30" EAST, FOR 100.00 FEET TO A POINT ON THE NORTHERLY RIGHT-OF-WAY LINE OF EMBASSY BOULEVARD, ALSO BEING THE SOUTHERLY BOUNDARY LINE OF SAID TRACT-D AND THE POINT OF BEGINNING; THENCE CONTINUE NORTH 00° 15' 30" EAST, FOR 10.00 FEET; THENCE SOUTH 89° 44' 30" EAST, FOR 10.00 FEET; THENCE SOUTH 00° 15' 30" WEST, FOR 10.00 FEET TO A POINT ON THE NORTHERLY RIGHT-OF-WAY LINE OF EMBASSY BOULEVARD, ALSO BEING THE SOUTHERLY BOUNDARY LINE OF

TRACT-D; THENCE ALONG SAID NORTHERLY RIGHT-OF-WAY LINE OF EMBASSY BOULEVARD, ALSO BEING THE SOUTHERLY BOUNDARY LINE OF SAID TRACT-D, NORTH 89° 44' 30" WEST, FOR 10.00 FEET TO THE POINT OF BEGINNING.

All of Debtor's estate, right, title and interest in, to and under the following described property whether now owned or hereinafter acquired by Debtor (collectively, the "Property"):

(a) Land. The real property described in Exhibit A attached hereto and made a part hereof (the "Land");

(b) Additional Land. All additional lands, estates and development rights hereafter acquired by Debtor for use in connection with the Land and the development of the Land and all additional lands and estates therein which may, from time to time, by supplemental mortgage or otherwise by expressly made subject to the lien of that certain mortgage, deed of trust, deed to secure debt or similar instrument executed by Debtor in connection herewith (the "Security Instrument");

(c) Improvements. The buildings, structures, fixtures, additions, enlargements, extensions, modifications, repairs, replacements and improvements now or hereafter erected or located on the Land (collectively, the "Improvements");

(d) Easements. All easements, rights-of-way or use, rights, strips and gores of land, streets, ways, alleys, passages, sewer rights, water, water courses, water rights and powers, air rights and development rights, and all estates, rights, titles, interests, privileges, liberties, servitudes, tenements, hereditaments and appurtenances of any nature whatsoever, in any way now or hereafter belonging, relating or pertaining to the Land and the Improvements and the reversions and remainders, and all land lying in the bed of any street, road or avenue, opened or proposed, in front of or adjoining the Land, to the center line thereof and all the estates, rights, titles, interests, rights of dower, rights of curtesy, property, possession, claim and demand whatsoever, both at law and in equity, of Debtor of, in and to the Land and the Improvements and every part and parcel thereof, with the appurtenances thereto;

(e) Equipment. All "equipment" as such term is defined in Article 9 of the Uniform Commercial Code (as hereinafter defined), now owned or hereafter acquired by Debtor, which is used at or in connection with the Improvements or the Land or is located thereon or therein (including, but not limited to, all machinery, equipment, furnishings, and electronic data-processing and other office equipment now owned or hereafter acquired by Debtor and any and all additions, substitutions and replacements of any of the foregoing), together with all attachments, components, parts, equipment and accessories installed thereon or affixed thereto (collectively, the "Equipment"). Notwithstanding the foregoing, Equipment shall not include any property belonging to tenants under leases except to the extent that Debtor shall have any right or interest therein;

(f) Fixtures. All Equipment now owned, or the ownership of which is hereafter acquired, by Debtor which is so related to the Land and Improvements forming part of the Property that it is deemed fixtures or real property under the law of the particular state in which the Equipment is located, including, without limitation, all building or construction materials intended for construction, reconstruction, alteration or repair of or installation on the Property, construction equipment, appliances, machinery, plant equipment, fittings, apparatuses, fixtures and other items now or hereafter attached to, installed in or used in connection with (temporarily or permanently) any of the Improvements or the Land, including but not limited to engines, devices for the opera-

tion of pumps, pipes, plumbing, call and sprinkler systems, fire extinguishing apparatuses and equipment, heating, ventilating, incinerating, electrical, air conditioning and air cooling equipment and systems, gas and electric machinery appurtenances and equipment, pollution control equipment, security systems, disposals, dishwashers, refrigerators and ranges, recreational equipment and facilities of all kinds, and water, gas, electrical, storm and sanitary sewer facilities, utility lines and equipment (whether owned individually or jointly with others, and, if owned jointly, to the extent of Debtor's interest therein) and all other utilities whether or not situated in easements, all water tanks, water supply, water power sites, fuel stations, fuel tanks, fuel supply, and all other structures, together with all accessions, appurtenances, additions, replacements, betterments and substitutions for any of the foregoing and the proceeds thereof (collectively, the "Fixtures"). Notwithstanding the foregoing, "Fixtures" shall not include any property which tenants are entitled to remove pursuant to leases except to the extent that Debtor shall have any rights or interest therein;

(g) Personal Property. All furniture, furnishings, objects of art, machinery, goods, tools, supplies, appliances, general intangibles, contract rights, accounts, accounts receivable, franchises, licenses, certificates and permits, and all other personal property of any kind or character whatsoever as defined in and subject to the provisions of the Uniform Commercial Code, whether tangible or intangible, other than Fixtures, which are now or hereafter owned by Debtor and which are located within or about the Land and the Improvements, together with all accessories, replacements and substitutions thereto or thereof and the proceeds thereof (collectively, the "Personal Property"), and the right, title and interest of Debtor in and to any of the Personal Property which may be subject to any security interests, as defined in the Uniform Commercial Code, as adopted and enacted by the state or states where any of the Property is located (the "Uniform Commercial Code"), superior in lien to the lien of the Security Instruments and all proceeds and products of the above;

(h) Leases and Rents. All leases, subleases or subsubleases, lettings, licenses, concessions or other agreements (whether written or oral) pursuant to which any Person is granted possessory interest in, or right to use or occupy all or any portion of the Land and the Improvements, and every modification, amendment or other agreement relating to such leases, subleases, subsubleases, or other agreements entered into in connection with such leases, subleases, subsubleases, or other agreements and every guarantee of the performance and observance of the covenants, conditions and agreements to be performed and observed by the other party thereto, heretofore or hereafter entered into (collectively, the "Leases"), whether before or after the filing by or against Debtor of any petition for relief under the Bankruptcy Code and all right, title and interest of Debtor, its successors and assigns therein and thereunder, including, without limitation, cash or securities deposited thereunder to secure the performance by the lessees of their obligations thereunder and all rents, additional rents, revenues, issues and profits (including all oil and gas or other mineral royalties and bonuses) from the Land and the Improvements whether paid or accruing before or after the filing by or against Debtor of any petition for relief under the Bankruptcy Code (collectively, the "Rents") and all proceeds from the sale or other disposition of the Leases and the right to receive and apply the Rents to the payment of the Debt;

(i) Condemnation Awards. All awards or payments, including interest thereon, which may

heretofore and hereafter be made with respect to the Property, whether from the exercise of the right of eminent domain (including, but not limited to, any transfer made in lieu of or in anticipation of the exercise of the right), or for a change of grade, or for any other injury to or decrease in the value of the Property;

(j) Insurance Proceeds. All proceeds in respect of the Property under any insurance policies covering the Property, including, without limitation, the right to receive and apply the proceeds of any insurance, judgments, or settlements made in lieu thereof, for damage to the Property;

(k) Tax Certiorari. All refunds, rebates or credits in connection with reduction in real estate taxes and assessments charged against the Property as a result of tax certiorari or any applications or proceedings for reduction;

(l) Conversion. All proceeds of the conversion, voluntary or involuntary, of any of the foregoing including, without limitation, proceeds of insurance and condemnation awards, into cash or liquidation claims;

(m) Rights. The right, in the name and on behalf of Debtor, to appear in and defend any action or proceeding brought with respect to the Property and to commence any action or proceeding to protect the interest of Secured Party in the Property;

(n) Agreements. All agreements, contracts, certificates, instruments, franchises, permits, licenses, plans, specifications and other documents, now or hereafter entered into, and all rights therein and thereto, respecting or pertaining to the use, occupation, construction, management or operation of the Land and any part thereof and any Improvements or any business or activity conducted on the Land and any part thereof and all right, title and interest of Debtor therein and thereunder, including, without limitation, the right, upon the happening of any default hereunder, to receive and collect any sums payable to Debtor thereunder;

(o) Trademarks. All tradenames, trademarks, servicemarks, logos, copyrights, goodwill, books and records and all other general intangibles relating to or used in connection with the operation of the Property;

(p) Accounts. All reserves, escrows and deposit accounts maintained by Debtor with respect to the Property and all cash, checks, drafts, certificates, securities, investment property, financial assets, instruments and other property held therein from time to time and all proceeds, products, distributions or dividends or substitutions thereon and thereof;

[and]  
(q) Other Rights. Any and all other rights of Debtor in and to the items set forth in Subsections (a) through (p) above.

ANY PERSON CLAIMING AN INTEREST IN THE SURPLUS FROM THE SALE, IF ANY, OTHER THAN THE PROPERTY OWNER AS OF THE DATE OF THE LIS PENDENS MUST FILE A CLAIM WITHIN 60 DAYS AFTER THE SALE.

If you are a person with a disability who needs any accommodation in order to participate in this proceeding, you are entitled, at no cost to you, to the provision of certain assistance. Please contact the Public Information Dept., Pasco County Government Center, 7530 Little Rd., New Port Richey, FL 34654; (727) 847-8110 (V) in New Port Richey; (352) 521-4274, ext 8110 (V) in Dade City, at least 7 days before your scheduled court appearance, or immediately upon receiving this notification if the time before the scheduled appearance is less than 7 days; if you are hearing impaired call 711. The court does not provide transportation and cannot accommodate for this service. Persons with disabilities needing transportation to court should contact their local public transportation providers for information regarding transportation services.

Attorney:  
Michael P. Woodbury, Esq.  
Margaret Brenan Correoso, Esq.  
Woodbury, Santiago & Correoso, P.A.  
9100 South Dadeland Boulevard, Suite 1702  
Miami, Florida 33156  
April 4, 11, 2014 14-01978P

**HOW TO PUBLISH  
YOUR LEGAL NOTICE  
IN THE**  
**Business  
Observer**

**FOR MORE INFORMATION, CALL:**

**(813) 221-9505 Hillsborough, Pasco**

**(727) 447-7784 Pinellas**

**(941) 906-9386 Manatee, Sarasota, Lee**

**(239) 263-0122 Collier**

**(407) 654-5500 Orange**

**(941) 249-4900 Charlotte**

Or e-mail: [legal@businessobserverfl.com](mailto:legal@businessobserverfl.com)

FIRST INSERTION

NOTICE OF SALE IN THE CIRCUIT COURT OF THE FIFTH JUDICIAL CIRCUIT IN AND FOR HERNANDO COUNTY, STATE OF FLORIDA CIVIL DIVISION  
**CASE NO. CA-13-2316**  
**BRANCH BANKING AND TRUST, a North Carolina banking corporation, Plaintiff, vs. ACCENT CUSTOM HOMES, INC., a Florida corporation; JOHN VASSILAGORIS, an individual; JOANNA PANOPOULOS, an individual; CACH, LLC, a Colorado limited liability company; CAPITAL CITY BANK, a Florida corporation; BEACON WOODS EAST MASTER ASSOCIATION, INC., a Florida corporation not-for-profit; BEACON WOODS EAST RECREATION ASSOCIATION, INC., a Florida corporation not-for-profit; FAIRWAY OAKS HOMEOWNERS' ASSOCIATION, INC., a Florida corporation not-for-profit; TAYLOR'S HEIGHTS HOMEOWNERS' ASSOCIATION, INC., an inactive Florida corporation; SPRING HILL COMMUNITY ASSOC, INC. f/k/a The Spring Hill Civic Association, Incorporated, a Florida corporation; UNKNOWN TENANT NO. 1; UNKNOWN TENANT NO. 2; UNKNOWN TENANT NO. 3; UNKNOWN TENANT NO. 4; UNKNOWN TENANT NO. 5; and ALL OTHER PARTIES CLAIMING BY, THROUGH, OR UNDER SAID DEFENDANTS, Defendants.**  
 Notice is hereby given that, pursuant to the Final Judgment of Foreclosure entered in the above-styled cause on April 1, 2014, the Clerk of the Circuit Court of Hernando County, Florida, will sell the real and personal property situated in Hernando County and Pasco County, Florida, described as follows:  
**LEGAL DESCRIPTION OF HERNANDO COUNTY PROPERTY**  
 Parcel 2: Lot 237, FAIRWAY OAKS UNIT THREE-A, according to the plat thereof, as recorded in Plat Book 29, Pages 29 through 34, inclusive, of the public records of Pasco County, Florida. Parcel No. 25-24-16-0070-00000-2370.  
 Parcel 3: The South 1/2 of Tract 30, of the PORT RICHEY LAND COMPANY SUBDIVISION, Section 36, Township 24 South, Range 16 East, Pasco County, Florida, according to the map or plat thereof as recorded in Plat Book 1, Pages 60 and 61, of the public records of Pasco County, Florida.  
 LESS AND EXCEPT that portion of Little Road Parcel 116.1

Right-of-Way, as recorded in Official Records Book 1731, Page 488, of the public records of Pasco County, Florida, lying in said South 1/2 of Tract 30. Parcel No. 36-24-16-0010-03000-0000.  
 Parcel 4: The Southwest 175.00 feet of Lot 41, OSCEOLA HEIGHTS UNIT ONE, as shown on the plat recorded in Plat Book 6, Page 121, of the public records of Pasco County, Florida, being further described as follows:  
 Commence at the most Northerly corner of said Lot 41, for a point of reference; thence along the Northwest line of said Lot 41, South 50 deg 44'12" West, 75.00 feet to the Point of Beginning; thence South 39 deg 15'48" East, 250.00 feet; thence South 50 deg 44'12" West, 175.00 feet; thence North 39 deg 15'48" West, 250.00 feet; thence North 50 deg 44'12" East, 175.00 feet to the Point of Beginning. Parcel No. 12-25-16-0020-00000-0411.  
 Parcel 5: Lots 57, 58 and 59, Block 124, MOON LAKE ESTATES UNIT EIGHT, according to the plat thereof, as recorded in Plat Book 4, Page(s) 98 and 99, of the public records of Pasco County, Florida. Parcel No. 16-25-17-0080-12400-0570  
 Parcel 6: Lots 1, 3 and 24, TAYLOR'S HEIGHTS, according to the plat thereof, as recorded in Plat Book 5, Page 164, of the public records of Pasco County, Florida. Parcel Nos. 04-26-16-0020-00000-0010, 04-26-16-0020-00000-0031, 04-26-16-0020-00000-0240.  
 Parcel 8: Lot 16, Block 172; Lot 25, Block 191; Lot 8, Block 188; and Lot 7, Block 186, SPRING HILL, UNIT 4, according to the map or plat thereof, as recorded in Plat Book 7, Page(s) 87 through 95, inclusive, of the public records of Hernando County, Florida. Parcel Nos. R32-323-17-5040-0172-0160, R32-323-17-5040-0191-0250, R32-323-17-5040-0188-0080, R32-323-17-5040-0186-0070.  
 Parcel 9: Lot 8, Block 213; Lot 18, Block 222; Lot 28, Block 229; Lot 2, Block 235; Lot 12, Block 236; Lot 3, Block 240; and Lot 8, Block 249, SPRING HILL, UNIT 5, according to the plat thereof, as recorded in Plat Book 7, Page(s) 96 through 107, inclusive, of the public records of Hernando County, Florida. Parcel Nos. R32-323-17-5050-0213-0080, R32-323-17-5050-0222-0180, R32-323-17-5050-0229-0280, R32-323-17-5050-0235-0020,

R32-323-17-5050-0236-0120, R32-323-17-5050-0240-0030, R32-323-17-5050-0249-0080. Parcel 10: Lot 20, Block 256 and Lot 14, Block 254, SPRING HILL, UNIT 6, according to the plat thereof, as recorded in Plat Book 8, Page(s) 1 through 10, inclusive, of the public records of Hernando County, Florida. Parcel Nos. R32-323-17-5060-0256-0200, R32-323-17-5060-0254-0140.  
 Parcel 11: Lot 19, Block 1457; Lot 11, Block 1467; and Lot 18, Block 1459, SPRING HILL, UNIT 21, according to the plat thereof, as recorded in Plat Book 9, Page(s) 81 through 96, inclusive, of the public records of Hernando County, Florida. Parcel Nos. R32-323-17-5210-1457-0190, R32-323-17-5210-1467-0110, R32-323-17-5210-1459-0180  
 Parcel 12: Lot 2, Block 1757 and Lot 6, Block 1759, SPRING HILL, UNIT 26, according to the plat thereof, as recorded in Plat Book 10, Page(s) 77 through 85, inclusive, of the public records of Hernando County, Florida. Parcel Nos. R32-323-17-5260-1757-0020, R32-323-17-5260-1759-0060  
**AND**  
 All tenements, hereditaments, easements, appurtenances, improvements, emblements, buildings, riparian rights, contract rights, other rights, construction materials, rents, issues and profits arising from the property, chattel papers, all intangibles and tangibles, all accounts, inventory, equipment, instruments, and all other collateral as more fully described in the Mortgage of Real Estate and Security Agreement, recorded on March 10, 2002, Official Records Book 5097, Page 2456 of the Public Records of Pasco County, Florida, and on March 5, 2003, in Official Records Book 1634, Page 1559 of the Public Records of Hernando.  
**LEGAL DESCRIPTIONS OF PASCO COUNTY PROPERTY**  
 Tract 41, said Tract 41, being otherwise described as Lots 1 through 44, inclusive, GOLF VIEW HEIGHTS, as recorded in Plat Book 3, Page 62, of the Public Records of Pasco County, Florida; same being a subdivision of said Tract 41 in Section 3, Township 26 South, Range 16 East, being designated and described in accordance with the plat of said Section 3, recorded in Plat Book 1, Page 61, LESS the West 435.60 feet of the South 100 feet of said Tract 41; LESS the West 25 feet of the North 230 feet of said Tract 41; AND LESS road right-of-ways to Pas-

co County, described in Official Records Book 1204, Page 747; including that portion of Grace Avenue as vacated in Resolution recorded in Official Records Book 1226, Page 1753, of the Public Records of Pasco County, Florida, all lying West of Rowan Road, being further described as follows:  
 A portion of Tract 41 of PORT RICHEY LAND COMPANY SUBDIVISION, as shown on plat recorded in Plat Book 1, Page 61, of the Public Records of Pasco County, Florida, which was resubdivided as a portion of Lots 1, 2, 23, 24 and 25 and a portion of Grace Avenue of GOLF VIEW HEIGHTS, as shown on plat recorded in Plat Book 3, Page 62, of the Public Records of Pasco County, Florida, more particularly described as follows: Commence at the Northwest corner of said Tract 41; thence run South 89 deg. 35'18" East, 25.00 feet along the North boundary line of said Tract 41; thence South 00 deg. 22'28" West, 25.00 feet to the South right-of-way line of Nebraska Avenue as now established and the POINT OF BEGINNING; thence run South 89 deg. 35'18" East, 40.04 feet along said South right-of-way line of Nebraska Avenue to the Westerly right-of-way line of Rowan Road as now established; thence South 27 deg. 20'07" East, 233.58 feet along said Easterly right-of-way line; thence North 89 deg. 36'14" West, 148.65 feet to the East right-of-way line of Baker Road as described in Official Records Book 774, Page 1326, of the Public Records of Pasco County, Florida; thence North 00 deg. 22'28" East, 206.77 feet along said Easterly right-of-way line to the POINT OF BEGINNING. Said portion of Grace Avenue being vacated in Official Records Book 1226, Page 1753, of the Public Records of Pasco County, Florida.  
 Subject to a perpetual easement for right of way being more particularly described as follows: A portion of Tract 41, of Port Richey Land Company Subdivision, as shown on the plat recorded in Plat Book 1, Page 61, of the public records of Pasco County, Florida, which was resubdivided as a portion of Lots 1, 2, 23, and 25, and a portion of Grace Avenue of Golf View Heights, as shown on plat recorded in Plat Book 3, Page 62, of the public records of Pasco County, Florida, being further described as follows: Commence at the Northwest corner of said Tract 41; thence run South 89°

35' 18" East, 25.00 feet along the North boundary line of said Tract 41; thence South 00° 22' 28" West, 25.00 feet to the Point of Beginning; thence South 89° 35' 18" East, 40.04 feet along the South right-of-way line of Nebraska Avenue as now established; thence South 27° 20' 07" East, 233.58 feet along the Westerly right-of-way line of Rowan Road as now established; thence North 89° 36' 14" West, 22.60 feet; thence North 27° 20' 07" West, 227.94 feet; thence North 89° 35' 18" West 15.06 feet; thence South 00° 22' 28" West, 201.77 feet; thence North 89° 36' 14" West, 5.00 feet; thence North 00° 22' 28" East, 206.77 feet along the West-right-of-way line of Baker Road as now established to the Point of Beginning. Address: 6235 and 6237 Rowan Road, New Port Richey, FL 34663-5023  
 Parcel ID No: 03-26-16-0070-04100-0010  
**AND**  
 All buildings, improvements, fixtures, equipment, accessions thereto, appurtenances and all replacements and additions thereof and thereto, all leases and rents therefrom, and all other collateral as more fully described in the Mortgage of Real Estate and Security Agreement, recorded on March 2, 2005, Official Records Book 6249, Page 1179 of the Public Records of Pasco County, Florida.  
**AND**  
 A part of Tracts 56 and 61, PORT RICHEY COMPANY SUBDIVISION, according to the plat thereof recorded in Plat Book 1, Page 61, of the Public Records of Pasco County, Florida, and described as follows:  
 Commence at the Southwest corner of EMBASSY HILLS UNIT FOUR, as per Plat Book 12, Pages 16 and 17, Public Records of Pasco County, Florida, run thence South 89° 44' 30" East, 85 feet; thence South 00° 09' 49" West, 630 feet to the POINT OF BEGINNING; thence run South 89° 44' 30" East, 181.27 feet; thence South 00° 03' 47" West, 200 feet; thence North 89° 44' 30" West, 181.62 feet; thence North 00° 09' 49" East, 200 feet to the POINT OF BEGINNING, lying and being in Section 22, Township 25 South, Range 16 East, Pasco County, Florida. Address: 9222 Regency Park Boulevard, Port Richey, FL 34663-5023  
 Parcel ID No: 22-25-16-0010-06100-0000  
**AND**  
 All buildings, improvements, fixtures, equipment, accessions

thereto, appurtenances and all replacements and additions thereof and thereto, all leases and rents therefrom, and all other collateral as more fully described in the Mortgage of Real Estate and Security Agreement, recorded on October 13, 2005, Official Records Book 6639, Page 713 of the Public Records of Pasco County, Florida.  
 at public sale, to the highest and best bidder, for cash, on June 3, 2014, at 11:00 a.m., in the First Floor Lobby near the information desk of the Hernando County Government Center located at 20 North Main Street, Brooksville, Florida 34601, in accordance with Chapter 45, Florida Statutes.  
**ANY PERSON CLAIMING AN INTEREST IN THE SURPLUS FROM THE SALE, IF ANY, OTHER THAN THE PROPERTY OWNER AS OF THE DATE OF THE LIS PENDENS MUST FILE A CLAIM WITHIN 60 DAYS AFTER THE SALE.**  
**HERNANDO COUNTY - AMERICANS WITH DISABILITIES ACT**  
 If you are a person with a disability who needs any accommodation in order to participate in this proceeding, you are entitled, at no cost to you, to the provision of certain assistance. Please contact the ADA Coordinator at the Office of the Trial Court Administrator, Hernando County Courthouse, 20 North Main Street, Brooksville, Florida 34601, Telephone (352) 754-4402, at least 7 days before your scheduled court appearance, or immediately upon receiving this notification if the time before the scheduled appearance is less than 7 days; if you are hearing or voice impaired, call 711.  
**PASCO COUNTY - AMERICANS WITH DISABILITIES ACT**  
 If you are a person with a disability who needs any accommodation in order to participate in this proceeding, you are entitled, at no cost to you, to the provision of certain assistance. Please contact the ADA Coordinator at the Office of the Trial Court Administrator, Hernando County Courthouse, 20 North Main Street, Brooksville, Florida 34601, Telephone (352) 754-4402, at least 7 days before your scheduled court appearance, or immediately upon receiving this notification if the time before the scheduled appearance is less than 7 days; if you are hearing or voice impaired, call 711.  
 Dated this 1st day of April, 2014.  
 /s/ Quinn A. Henderson  
 QUINN A. HENDERSON  
 Florida Bar No. 652091  
 Primary: quinn.henderson@arlaw.com  
 Secondary: marylou.george@arlaw.com  
 Secondary: betty.ma@arlaw.com  
**ADAMS AND REESE LLP**  
 150 Second Avenue North, 17th Floor  
 St. Petersburg, FL 33701  
 Telephone: (727) 502-8295  
 Facsimile: (727) 502-8995  
 Attorneys for Plaintiff, Florida Bank  
 April 4, 11, 2014 14-02023P

FIRST INSERTION

NOTICE OF RESCHEDULED SALE IN THE CIRCUIT COURT OF THE SIXTH JUDICIAL CIRCUIT IN AND FOR PASCO COUNTY, FLORIDA CIVIL ACTION  
**CASE NO.:**  
**51-2011-CA-000162-CAAX-ES**  
**WELLS FARGO BANK, N.A., Plaintiff, vs. ANNA L. KELLEY, et al, Defendant(s).**  
 NOTICE IS HEREBY GIVEN Pursuant to an Order Rescheduling Foreclosure Sale dated on or about March 4, 2014, and entered in Case No. 51-2011-CA-000162-CAAX-ES of the Circuit Court of the Sixth Judicial Circuit in and for Pasco County, Florida in which Wells Fargo Bank, N.A., is the Plaintiff and Anna L. Kelley, Tenant #1 N/K/A Vince, are defendants, the Pasco County Clerk of the Circuit Court will sell to the highest and best bidder for cash in/on held online www.pasco.realforeclose.com: in Pasco County, Florida, Pasco County, Florida at 11:00AM on the 21st day of April, 2014, the following described property as set forth in said Final Judgment of Foreclosure:  
 LOT 10: COMMENCING AT A POINT 20 FEET SOUTH OF THE NORTHEAST CORNER OF TRACT 40, THENCE WEST 165 FEET, THENCE SOUTH 70 FEET; THENCE EAST 165 FEET; THENCE NORTH 70 FEET TO THE POINT OF BEGINNING, IN SECTION 25, TOWNSHIP 26 SOUTH, RANGE 21 EAST, OF CRYSTAL SPRINGS COLONY FARMS, AS PER PLAT THEREOF RECORDED IN PLAT BOOK 2, PAGE 24, PUBLIC RECORDS OF PASCO COUNTY, FLORIDA, TOGETHER WITH A 40 FOOT EASEMENT FOR INGRESS AND EGRESS ACROSS AND ALONG THE ROADWAYS AS THEY NOW EXIST.  
 THE EAST 165.00 FEET OF TRACT 40, LESS THE SOUTH 640.00 FEET, THEREOF, LYING IN SECTION 25, TOWNSHIP 26 SOUTH, RANGE 21 EAST, OF CRYSTAL SPRINGS COLONY FARMS, AS PER PLAT THEREOF RECORDED IN PLAT BOOK 2, PAGE 24,

PUBLIC RECORDS OF PASCO COUNTY, FLORIDA.  
 TOGETHER WITH A MOBILE HOME AS A PERMANENT FIXTURE AND APPURTENANCE THERETO, DESCRIBED AS: A 1984 SUNS SINGLEWIDE MOBILE HOME BEARING IDENTIFICATION NUMBER SSMFLAB90854 AND TITLE NUMBER 0020915340.  
 A/K/A 2452 CORVILLA DR., ZEPHYRHILLS, FL 33540  
 Any person claiming an interest in the surplus from the sale, if any, other than the property owner as of the date of the Lis Pendens must file a claim within 60 days after the sale.  
 If you are a person with a disability who needs an accommodation in order to participate in this proceeding, you are entitled, at no cost to you, to the provision of certain assistance. Please contact:  
 Public Information Dept., Pasco County Government Center 7530 Little Rd. New Port Richey, FL 34654 Phone: 727.847.8110 (voice) in New Port Richey 352.521.4274, ext 8110 (voice) in Dade City Or 711 for the hearing impaired  
 Contact should be initiated at least seven days before the scheduled court appearance, or immediately upon receiving this notification if the time before the scheduled appearance is less than seven days.  
 The court does not provide transportation and cannot accommodate such requests. Persons with disabilities needing transportation to court should contact their local public transportation providers for information regarding transportation services.  
 Dated in Hillsborough County, Florida on this 27th day of March, 2014.  
 /s/ Erik Del'Etoile  
 Erik Del'Etoile, Esq.  
 FL Bar # 71675  
 Albertelli Law  
 Attorney for Plaintiff  
 P.O. Box 23028  
 Tampa, FL 33623  
 (813) 221-4743  
 (813) 221-9171 facsimile  
 eService: servealaw@albertellilaw.com  
 BM - 10-64973  
 April 4, 11, 2014 14-01948P

FIRST INSERTION

NOTICE OF SALE IN THE CIRCUIT COURT OF THE SIXTH JUDICIAL CIRCUIT OF THE STATE OF FLORIDA, IN AND FOR PASCO COUNTY CIVIL DIVISION  
**CASE NO.**  
**51-2009-CA-004452-CAAX-ES**  
**BAC HOME LOANS SERVICING, L.P., Plaintiff, vs. JAMES MILEY A/K/A JAMES MILEY, JR.; UNKNOWN SPOUSE OF JAMES MILEY A/K/A JAMES MILEY, JR.; KRISTI MILEY A/K/A CHRISTINA MILEY A/K/A CHRISTINA TELLIER; UNKNOWN SPOUSE OF KRISTI MILEY A/K/A CHRISTINA MILEY A/K/A CHRISTINA TELLIER; IF LIVING, INCLUDING ANY UNKNOWN SPOUSE OF SAID DEFENDANT(S), IF REMARRIED, AND IF DECEASED, THE RESPECTIVE UNKNOWN HEIRS, DEVISEES, GRANTEEES, ASSIGNEES, CREDITORS, LIENORS, AND TRUSTEES, AND ALL OTHER PERSONS CLAIMING BY, THROUGH, UNDER OR AGAINST THE NAMED DEFENDANT(S); UNKNOWN TENANT #1; UNKNOWN TENANT #2; Defendant(s)**  
 Notice is hereby given that, pursuant to a Final Summary Judgment of Foreclosure entered on 01/21/2014 in the above-styled cause, in the Circuit Court of Pasco County, Florida, the office of Paula S. O'Neil clerk of the circuit court will sell the property situate in Pasco County, Florida, described as:  
 LOT 45B OF ANGUS VALLEY UNIT NO. 1, A TRACT OF LAND LYING IN SECTION 11, TOWNSHIP 26 SOUTH, RANGE 19 EAST, PASCO COUNTY, FLORIDA, MORE PARTICULARLY DESCRIBED AS FOLLOWS:  
 BEGIN AT THE NORTHWEST CORNER OF STATED SECTION 11; THENCE EAST (ASSUMED BEARING), A DISTANCE OF 3348.38 FEET FOR A POINT OF BEGINNING; THENCE CON-

TINUE EAST, A DISTANCE OF 118.00 FEET; THENCE SOUTH, A DISTANCE OF 327.94 FEET; THENCE SOUTH 01 DEGREES 06' 42" EAST, A DISTANCE OF 30.00 FEET; THENCE SOUTH 88 DEGREES 53' 18 " WEST, A DISTANCE OF 118.02 FEET; THENCE NORTH 01 DEGREES 06' 42" WEST, A DISTANCE 30.00 FEET; THENCE NORTH, A DISTANCE OF 330.24 FEET TO THE POINT OF BEGINNING; LESS ANY PART OF THEREOF FOR ROAD RIGHT-OF-WAY PURPOSES  
 at public sale, to the highest and best bidder, for cash, www.pasco.realforeclose.com at 11:00 o'clock, A.M., on April 22, 2014  
 Any person claiming an interest in the surplus from the sale, if any, other than the property owner as of the date of the lis pendens, must file a claim within 60 days after the sale.  
 If you are a person with a disability who needs any accommodation in order to participate in this proceeding, you are entitled, at no cost to you, to the provision of certain assistance. Please contact the Public Information Dept., Pasco County Government Center, 7530 Little Rd., New Port Richey, FL 34654; (727) 847-8110 (V) for proceedings in New Port Richey; (352) 521-4274, ext. 8110 (V) for proceedings in Dade City, at least 7 days before your scheduled court appearance, or immediately upon receiving this notification if the time before the scheduled appearance is less than 7 days; if you are hearing impaired call 711.  
 Date: 04/01/2014  
 ATTORNEY FOR PLAINTIFF  
 By /S/ Josh D. Donnelly  
 Josh D. Donnelly  
 Florida Bar #64788  
 THIS INSTRUMENT PREPARED BY:  
 Law Offices of Daniel C. Consuegra  
 9204 King Palm Drive  
 Tampa, FL 33619-1328  
 Phone: 813-915-8660  
 Attorneys for Plaintiff  
 41568-T  
 April 4, 11, 2014 14-02024P

FIRST INSERTION

NOTICE OF FORECLOSURE SALE IN THE CIRCUIT COURT OF THE 6TH JUDICIAL CIRCUIT, IN AND FOR PASCO COUNTY, FLORIDA CIVIL DIVISION:  
**CASE NO.:**  
**512012CA002148XXXXES**  
**DEUTSCHE BANK NATIONAL TRUST COMPANY, AS TRUSTEE FOR H S I ASSET LOAN OBLIGATION TRUST 2006-2, MORTGAGE PASS-THROUGH CERTIFICATES, SERIES 2006-2, Plaintiff, vs. RAFIC A. ABOUJAOUDE; LAKE BERNADETTE COMMUNITY ASSOCIATION, INC.; WELLS FARGO BANK, NA SUCCESSOR BY MERGER TO WACHOVIA BANK, NATIONAL ASSOCIATION; UNKNOWN TENANT IN POSSESSION OF THE SUBJECT PROPERTY, Defendants.**  
 NOTICE IS HEREBY GIVEN pursuant to Final Judgment of Foreclosure dated the 11th day of March, 2014, and entered in Case No. 512012CA002148XXXXES, of the Circuit Court of the 6TH Judicial Circuit in and for Pasco County, Florida, wherein DEUTSCHE BANK NATIONAL TRUST COMPANY, AS TRUSTEE FOR H S I ASSET LOAN OBLIGATION TRUST 2006-2, MORTGAGE PASS-THROUGH CERTIFICATES, SERIES 2006-2 is the Plaintiff and RAFIC A. ABOUJAOUDE; LAKE BERNADETTE COMMUNITY ASSOCIATION, INC.; WELLS FARGO BANK, NA SUCCESSOR BY MERGER TO WACHOVIA BANK, NATIONAL ASSOCIATION and UNKNOWN TENANT(S) IN POSSESSION OF THE SUBJECT PROPERTY are defendants. The Clerk of this Court shall sell to the highest and best bidder for cash, on the 28th day of April, 2014, at 11:00 AM on Pasco County's Public Auction website: www.pasco.realforeclose.com, pursuant to judgment or order of the Court, in accordance with Chapter 45, Florida Statutes, the following described property as set forth in

said Final Judgment, to wit:  
 LOT 2, BLOCK 4, LAKE BERNADETTE PARCELS 17 AND 18A, AS PER PLAT THEREOF, RECORDED IN PLAT BOOK 55, PAGES 42 THROUGH 48, INCLUSIVE, OF THE PUBLIC RECORDS OF PASCO COUNTY, FLORIDA  
**IDA**  
**ANY PERSON CLAIMING AN INTEREST IN THE SURPLUS FROM THE SALE, IF ANY, OTHER THAN THE PROPERTY OWNER AS OF THE DATE OF THE LIS PENDENS MUST FILE A CLAIM WITHIN 60 DAYS AFTER THE SALE.**  
 If you are a person with a disability who needs any accommodation in order to participate in this proceeding, you are entitled, at no cost to you, to the provision of certain assistance. Please contact the Public Information Dept., Pasco County Government Center, 7530 Little Rd., New Port Richey, FL 34654; (727) 847-8110 (V) in New Port Richey; (352) 521-4274, ext 8110 (V) in Dade City, at least 7 days before your scheduled court appearance, or immediately upon receiving this notification if the time before the scheduled appearance is less than 7 days; if you are hearing impaired call 711. The court does not provide transportation and cannot accommodate for this service. Persons with disabilities needing transportation to court should contact their local public transportation providers for information regarding transportation services.  
 Dated this 1 day of April, 2014.  
 By: Jennifer Nicole Tarquinio  
 Bar #99192  
 Submitted by:  
 Choice Legal Group, P.A.  
 P.O. Box 9908  
 Fort Lauderdale, FL 33310-9908  
 Telephone: (954) 453-0365  
 Facsimile: (954) 771-6052  
 Toll Free: 1-800-441-2438  
 DESIGNATED PRIMARY E-MAIL FOR SERVICE PURSUANT TO FLA. R. JUD. ADMIN 2.516  
 eservice@legalgroup.com  
 11-16210  
 April 4, 11, 2014 14-02035P

## FIRST INSERTION

**NOTICE OF SALE  
IN THE CIRCUIT COURT OF THE  
SIXTH JUDICIAL CIRCUIT IN AND  
FOR PASCO COUNTY, FLORIDA  
Case No.: 51-2010-CA-0269-WS-J3  
BRANCH BANKING AND TRUST  
COMPANY, a North Carolina  
banking corporation, as  
successor-in-interest to Colonial  
Bank by asset acquisition from  
the FDIC as Receiver for Colonial  
Bank,  
Plaintiff, v.  
JEFFREY A. BONYNGE,  
individually, FLORIDA WASH  
DESIGN, LLC, a Florida limited  
liability company, and PRISTINE &  
CLEAN, INC., a Florida  
corporation, SUNBELT RENTALS,  
INC.,  
Defendants.**

Notice is hereby given that pursuant to the Final Judgment of Foreclosure in the case of Branch Banking and Trust Company, Plaintiff, v. Jeffrey A. Bonyng, individually, et al., Case No.: 51-2010-CA-0269-WS-J3, the undersigned Clerk of the Circuit Court in Pasco County, Florida will on April 25, 2014, at 11:00 a.m., via the www.pasco.realforeclose.com website, shall offer the identified property set forth herein for sale and sell at public outcry to the highest bidder for cash involving the following real or personal property, situate, lying and being in Pasco County, Florida (the "Property") described as follows:

Lot B, BROWN ACRES UNIT ONE, according to the map or plat thereof, as recorded in Plat Book 7, Page 105, of the Public Records of Pasco County, Florida, less the Easterly 57 feet thereof to the State of Florida for U.S. Hwy. 19 Right of Way;

AND  
Lot 2, BROWN ACRES UNIT ONE, according to the map or plat thereof, as recorded in Plat Book 7, Page 105, of the Public Records of Pasco County, Florida;

AND  
A portion of Tract 36, PORT RICHEY LAND COMPANY'S SUBDIVISION of Section 9, Township 25 South, Range 16 East, according to the map or plat thereof, as recorded in Plat Book 1, Page 61, of the Public Records of Pasco County, Florida, being further described as: Commence at the Southwest corner of Lot 4, BROWN ACRES UNIT ONE, according to the map or plat thereof, as recorded in Plat Book 7, Page 105, of the Public Records of Pasco County, Florida; thence run along the South line of said Lot 4, 56.00 feet for a Point of Beginning; thence run along the South line of Lot 2 of said Brown Acres Unit One, North 89°59'08" East, a distance of 56.00 feet to the West line of Lot B of said Brown Acres Unit One, thence South 00°00'52" East, 79.01 feet to the South line of said Tract 36; thence

South 89°56'11" West along said South line of Tract 36, 56.00 feet; thence North 00°00'52" West 79.06 feet to the Point of Beginning (a/k/a Lot 2-A of the unrecorded Plat of Brown Acres West);  
AND  
Lot 4, BROWN ACRES UNIT ONE, according to the map or plat thereof, as recorded in Plat Book 7, Page 105, of the Public Records of Pasco County, Florida;

AND  
A portion of Tract 36, PORT RICHEY LAND COMPANY'S SUBDIVISION of Section 9, Township 25 South, Range 16 East, according to the map or plat thereof, as recorded in Plat Book 1, Page 61, of the Public Records of Pasco County, Florida, and being further described as follows: Commence at the Southwest corner of Lot 4, BROWN ACRES UNIT ONE, according to the map or plat thereof, as recorded in Plat Book 7, Page 105, of the Public Records of Pasco County, Florida; thence run along the South line of said Lot 4, 56.00 feet to the West line of Lot 2 of said Brown Acres, Unit One, thence South 00°00'52" East, 79.06 feet to the South line of said Tract 36; thence South 89°56'11" West along said South line of Tract 36, 56.00 feet; thence North 00°00'52" West, 79.11 feet to the Point of Beginning (a/k/a Lot 4-A of the unrecorded Plat of Brown Acres West);  
LESS and EXCEPT that portion of Lot 4, BROWN ACRES UNIT ONE, according to the map or plat thereof, as recorded in Plat Book 7, Page 105, of the Public Records of Pasco County, Florida, conveyed in Official Records Book 6962, Page 1315, being further described as follows:

Commence at the Northwest corner of Lot 4 for a Point of Beginning; run thence North 89°59'08" East along the North line of said Lot 4, a distance of 56.00 feet; thence South 00°00'52" East along the East line of said Lot 4, a distance of 74.00 feet; thence South 53°06'56" West, a distance of 10.00 feet; thence South 00°00'52" East, a distance of 8.00 feet; thence South 89°59'08" West, a distance of 48.00 feet to a point on the West line of said Lot 4; thence North 00°00'52" West along said West line, a distance of 88.00 feet to the Point of Beginning.

AND THE PERSONAL PROPERTY DESCRIBED AS FOLLOWS:

a. Improvements. All buildings, structures, betterments, fruit trees, groves and other improvements of any nature now or hereafter situated in whole or in part upon the lands in Pasco

County, Florida, described on this Exhibit "A" (the "Land"), regardless of whether physically affixed thereto or severed or capable of severance therefrom (the "Improvements").

b. Appurtenances. The benefit of all easements and other rights of any nature whatsoever appurtenant to the Land or the Improvements, or both, and all rights of way, streets, alleys, passages, drainage rights, sewer rights, and rights of ingress and egress to the Land, and all adjoining property, whether now existing or hereafter arising, together with the reversion or reversions, remainder or remainders, rents, issues incomes, and profits of any of the foregoing.

c. Tangible Property. All of Debtor's interest in all fixtures, equipment, crops now sown and/or growing in the future and tangible personal property of any nature whatsoever now or hereafter (i) attached or affixed to the Land or the Improvements, or both, regardless of whether physically affixed thereto or severed or capable of severance therefrom, or (ii) regardless of where situated, used, usable, or intended to be used in connection with any present or future use or operation of or upon the Land. The foregoing includes: all heating, air conditioning, lighting, incinerating, and power equipment; all engines, compressors, pipes, pumps, tanks, motors, conduits, wiring, and switchboards; all plumbing, lifting, cleaning, fire prevention, fire extinguishing, refrigerating, ventilating, and communications apparatus; all boilers, furnaces, oil burners, vacuum cleaning systems, elevators, and escalators; all stoves, ovens, ranges, disposal units, dishwashers, water heaters, exhaust systems, refrigerators, cabinets, and partitions; all rugs and carpets; all laundry equipment; all building materials; all furniture, furnishings, office equipment, and office supplies (including stationery, letterheads, billheads, and items of a similar nature); and all additions, accessions, renewals, replacements, and substitutions of any or all of the foregoing (the "Tangible Property").

d. Income. All rents, issues, incomes, and profits in any manner arising from the Land, Improvements, or Tangible Property, or any combination, or including Debtor's interest in and to all leases, licenses, franchises, and concessions of, or relating to, all or any portion of the Land, Improvements or Tangible Property, whether now existing or hereafter made, including all amendments, modifications, replacements, substitutions, extensions, renewals, or consolida-

tions. The foregoing items are jointly and severally called the "Rents" in this instrument.

e. Proceeds. All proceeds of the conversion voluntary or involuntary, of any of the property described in this Exhibit into cash or other liquidated claims, or that are otherwise payable for injury to, or taking or requisitioning of, any such property, including all insurance and condemnation proceeds.

f. Contract Rights. All of Debtors right, title and interest in and to any and all contracts, written or oral, expressed or implied, now existing or hereafter entered into or arising, in any manner related to the improvements, use, combination, including any and all deposits, prepaid items and payments due and to become due thereunder, and including construction contracts, service contracts, advertising contracts, purchase orders, and equipment leases.

g. Name. All right title and interest of Debtor in and to any trade name now or hereafter used in connection with the operation of the Land, and all related marks, logos and insignia.

h. Other Intangibles. All contract rights, accounts, instruments and general intangibles, as such terms from time to time are defined in the Florida Uniform Commercial Code, in any manner related to the use, operation, sale, conversion, or other disposition (voluntary or involuntary) of the Land, Improvements, Tangible Property, or Rents, including all permits, licenses, insurance policies, rights of action and other choses in action.

i. Construction Materials. All lumber, concrete block, dry-wall, sheet rock, concrete, roof trusses, beams, joints, or any other personal property used or intended to be used in connection with the construction of any improvements on the Land or any of such items of personal property which are intended to be incorporated into the Land as an Improvement thereon.

j. Sewer Fees. All sewer capacity reservation fees and/or reserved sewer capacity, all tap in rights, all impact fees, all of which may benefit the Land or Improvements.

k. Plan. Any and all plans, specifications, permits, including building permits, licenses, fees, architectural drawings, surveys and plats associated with the construction of any proposed improvements to the Land.

l. Construction Documents. The foregoing types of property include specifically all of the following: all contracts, plans and documents that concern the design and construction of the improvements, including plans

and specifications, drawings and architectural and/or engineering contracts, and construction contracts, together with all amendments, revisions, modifications and supplements.

m. Secondary Financing. All of Debtor's rights, power or privilege to further encumber any of the property described in this paragraph for debt.

n. Business Assets. All of Debtors accounts, contract rights, chattel paper, instruments: drafts and general intangibles, whether now existing or hereafter arising or acquired (herein collectively referred to as the "Receivables"), and all of Debtor's interest in goods which shall have given or shall give rise to such Receivables, whether now existing or hereafter arising or acquired, including without limitation all of Debtor's right, title and interest in and to all lease agreements and rental contracts entered into between Debtor and its customers (including, without limitation, all rents, revenues, income claims and rights to money arising under said lease agreements and rental contracts, or contract rights, benefits, discretions, and powers arising thereunder), and all of Debtor's rights, title and interest in all Inventory (as defined below), which is the subject of such lease agreements and rental contracts; all inventory of Debtor, including all raw materials, goods in process, and finished goods of every kind or character, whether presently in existence or hereafter acquired and wherever located, and all direct and remote proceeds thereof (all such property is herein collectively referred to as the "Inventory"); all of Debtor's machinery, equipment, removable trade fixtures, furniture, furnishings, leasehold improvements and all other goods and tangible personal property of every kind and description whatsoever used or bought for use primarily in Debtor's business whether now owned or hereafter acquired by Debtor, together with all service contracts and manufacturer's or dealer's warranties relating thereto, all additions, replacements and substitutions thereto or therefor, as well as all attachments, accessions, parts materials, supplies and accessories now or hereafter installed therein, affixed thereto or used in connection therewith (all of such property being hereinafter collectively referred to as the "Equipment"), and any other property of any nature whatsoever of Debtor now or hereafter with or in the possession of or assigned or hypothecated to the Secured Party for any purpose, including, but not limited to, balances, credits, deposits, accounts, items and

moneys of Debtor now or hereafter with the Secured Party, and all dividends and distributions on or rights in connection with any such property. All of such property (including without limitation the Equipment the Inventory and the Receivables) shall also include all direct and remote proceeds thereof. As used herein, "proceeds" includes not only what is received upon sale, exchange, collection or other disposition of the aforementioned collateral or loss of or damage to collateral, but also all rents, profits and other revenues (including without limitation chattel paper, instruments, and money) derived from renting, leasing or otherwise permitting the use of the aforementioned collateral of the business now known as FLORIDA WASH DESIGN, LLC, a Florida limited liability company, having an address of 11227 US Highway 19, Port Richey, FL whether such items are now owned hereafter acquired or owing to Debtor, and wherever such items are located. As used in this paragraph, the term "include," "includes" or "including" is for illustrative purposes only and is always without limitation.

Any person claiming an interest in the surplus from the sale, if any, other than the property owner as of the date of the Notice of Lis Pendens, must file a claim within 60 days after the sale.

If you are a person with a disability who needs any accommodation in order to participate in this proceeding, you are entitled, at no cost to you, to the provision of certain assistance. Please contact the Public Information Dept., Pasco County Government Center, 7530 Little Rd., New Port Richey, FL 34654; (727) 847-8110 (V) in New Port Richey; (352) 521-4274, ext 8110 (V) in Dade City, at least 7 days before your scheduled court appearance, or immediately upon receiving this notification if the time before the scheduled appearance is less than 7 days; if you are hearing impaired call 711. The court does not provide transportation and cannot accommodate for this service. Persons with disabilities needing transportation to court should contact their local public transportation providers for information regarding transportation services.

DATED this 2nd day of April, 2014.

W. Glenn Jensen, Esq.  
Florida Bar No. 0126070  
gjensen@ralaw.com  
yhibbert@ralaw.com  
Mychal J. Katz, Esq.  
Florida Bar No. 0037588  
mkatz@ralaw.com  
nspeth@ralaw.com

ROETZEL & ANDRESS, LPA

P.O. Box 6507  
Orlando, FL 32802-6507  
Phone: (407) 896.2224  
Fax: (407) 835.3596  
C/M 122734.0011  
April 4, 11, 2014 14-02039P

## FIRST INSERTION

**NOTICE OF FORECLOSURE SALE  
IN THE CIRCUIT COURT OF THE  
6TH JUDICIAL CIRCUIT, IN AND  
FOR PASCO COUNTY, FLORIDA  
CIVIL DIVISION:  
CASE NO.:**

**51-2009-CA-003851-WS  
COUNTRYWIDE HOME LOANS  
SERVICING, L.P.,  
Plaintiff, vs.  
JANEL E. GLEASON; KEVIN  
J. GLEASON; MORTGAGE  
ELECTRONIC REGISTRATION  
SYSTEMS INCORPORATED,  
AS A NOMINEE FOR  
COUNTRYWIDE BANK, A  
DIVISION OF TREASURY  
BANK, N.A.; SOUTHERN OAKS  
OF PASCO HOMEOWNERS  
ASSOCIATION, INC.;  
UNKNOWN TENANT(S); IN  
POSSESSION OF THE SUBJECT  
PROPERTY,  
Defendants.**

NOTICE IS HEREBY GIVEN pursuant to Final Judgment of Foreclosure dated the 26th day of February, 2014, and entered in Case No. 51-2009-CA-003851-WS -, of the Circuit Court of the 6TH Judicial Circuit in and for Pasco County, Florida, wherein NATIONSTAR MORTGAGE LLC is the Plaintiff and JANEL E. GLEASON; KEVIN J. GLEASON; MORTGAGE ELECTRONIC REGISTRATION SYSTEMS INCORPORATED, AS A NOMINEE FOR COUNTRYWIDE BANK, A DIVISION OF TREASURY BANK, N.A.; SOUTHERN OAKS OF PASCO HOMEOWNERS ASSOCIATION, INC. and UNKNOWN TENANT(S) IN POSSESSION OF THE SUBJECT PROPERTY are defendants. The Clerk of this Court shall sell to the highest and best bidder for cash, on the 17th day of April, 2014, at 11:00 AM on Pasco County's Public Auction website: www.pasco.realforeclose.com, pursuant to judgment or order of the Court, in accordance with Chapter 45, Florida Statutes, the following described property as set forth in said Final Judgment, to wit:

LOT 370, SOUTHERN OAKS UNIT FOUR, ACCORDING TO THE MAP OR PLAT THEREOF AS RECORDED IN PLAT BOOK 37, PAGE 43, PUBLIC RECORDS OF PASCO COUNTY, FLORIDA

ANY PERSON CLAIMING AN INTEREST IN THE SURPLUS FROM THE SALE, IF ANY, OTHER THAN THE PROPERTY OWNER AS OF THE DATE OF THE LIS PENDENS MUST FILE A CLAIM WITHIN 60 DAYS AFTER THE SALE.

If you are a person with a disability who needs any accommodation in order to participate in this proceeding, you are entitled, at no cost to you, to the provision of certain assistance. Please contact the Public Information Dept., Pasco County Government Center, 7530 Little Rd., New Port Richey, FL 34654; (727) 847-8110 (V) in New Port Richey; (352) 521-4274, ext 8110 (V) in Dade City, at least 7 days before your scheduled court appearance, or immediately upon receiving this notification if the time before the scheduled appearance is less than 7 days; if you are hearing impaired call 711. The court does not provide transportation and cannot accommodate for this service. Persons with disabilities needing transportation to court should contact their local public transportation providers for information regarding transportation services.

Dated this 31st day of March, 2014.

By: Carri L. Pereyra  
Bar #17441

Submitted by:  
Choice Legal Group, P.A.  
P.O. Box 9908  
Fort Lauderdale, FL 33310-9908  
Telephone: (954) 453-0365  
Facsimile: (954) 771-6052  
Toll Free: 1-800-441-2438  
DESIGNATED PRIMARY E-MAIL  
FOR SERVICE PURSUANT TO FLA.  
R. JUD. ADMIN 2.516  
cservice@clelegalgroup.com  
09-13853  
April 4, 11, 2014 14-01986P

## FIRST INSERTION

**RE-NOTICE OF  
FORECLOSURE SALE  
IN THE CIRCUIT COURT OF THE  
6TH JUDICIAL CIRCUIT, IN AND  
FOR PASCO COUNTY, FLORIDA  
CIVIL DIVISION:  
CASE NO.:**

**51-2012-CA-006485WS  
JPMORGAN CHASE BANK,  
NATIONAL ASSOCIATION,  
Plaintiff, vs.  
ELIZABETH W. CAMPBELL;  
THOUSAND OAKS EAST  
- PHASES II AND III  
HOMEOWNERS' ASSOCIATION,  
INC.; THOUSAND OAKS  
MASTER ASSOCIATION,  
INC.; UNKNOWN SPOUSE OF  
ELIZABETH W. CAMPBELL;  
UNKNOWN TENANT IN  
POSSESSION OF THE SUBJECT  
PROPERTY,  
Defendants.**

NOTICE IS HEREBY GIVEN pursuant to an Order Resetting Foreclosure Sale dated the 19th day of March, 2014, and entered in Case No. 51-2012-CA-006485WS, of the Circuit Court of the 6TH Judicial Circuit in and for Pasco County, Florida, wherein JPMORGAN CHASE BANK, NATIONAL ASSOCIATION is the Plaintiff ELIZABETH W. CAMPBELL; THOUSAND OAKS EAST - PHASES II AND III HOMEOWNERS' ASSOCIATION, INC.; THOUSAND OAKS MASTER ASSOCIATION, INC. and UNKNOWN TENANT(S) IN POSSESSION OF THE SUBJECT PROPERTY are defendants. The Clerk of this Court shall sell to the highest and best bidder for cash, on the 25th day of April, 2014, at 11:00 AM on Pasco County's Public Auction website: www.pasco.realforeclose.com, pursuant to judgment or order of the Court, in accordance with Chapter 45, Florida Statutes, the following described property as set forth in said Final Judgment, to wit:

LOT 237, IN THOUSAND OAKS EAST PHASES II AND

III, ACCORDING TO THE MAP OR PLAT THEREOF AS RECORDED IN PLAT BOOK 46, PAGE 40, OF THE PUBLIC RECORDS OF PASCO COUNTY, FLORIDA.

ANY PERSON CLAIMING AN INTEREST IN THE SURPLUS FROM THE SALE, IF ANY, OTHER THAN THE PROPERTY OWNER AS OF THE DATE OF THE LIS PENDENS MUST FILE A CLAIM WITHIN 60 DAYS AFTER THE SALE.

If you are a person with a disability who needs any accommodation in order to participate in this proceeding, you are entitled, at no cost to you, to the provision of certain assistance. Please contact the Public Information Dept., Pasco County Government Center, 7530 Little Rd., New Port Richey, FL 34654; (727) 847-8110 (V) in New Port Richey; (352) 521-4274, ext 8110 (V) in Dade City, at least 7 days before your scheduled court appearance, or immediately upon receiving this notification if the time before the scheduled appearance is less than 7 days; if you are hearing impaired call 711. The court does not provide transportation and cannot accommodate for this service. Persons with disabilities needing transportation to court should contact their local public transportation providers for information regarding transportation services.

Dated this 31 day of March, 2014.

By: Jennifer Nicole Tarquinio  
Bar #99192

Submitted by:  
Choice Legal Group, P.A.  
P.O. Box 9908  
Fort Lauderdale, FL 33310-9908  
Telephone: (954) 453-0365  
Facsimile: (954) 771-6052  
Toll Free: 1-800-441-2438  
DESIGNATED PRIMARY E-MAIL  
FOR SERVICE PURSUANT TO FLA.  
R. JUD. ADMIN 2.516  
cservice@clelegalgroup.com  
10-61328  
April 4, 11, 2014 14-01987P

## FIRST INSERTION

**NOTICE OF FORECLOSURE SALE  
IN THE CIRCUIT COURT OF THE  
6th JUDICIAL CIRCUIT IN AND  
FOR PASCO COUNTY, FLORIDA  
CASE NO.:**

**51-2010-CA-006797-WS-J3  
WELLS FARGO BANK, N.A.,  
Plaintiff, vs.  
HEIRS, DEVISEES,  
GRANTEES, CREDITORS AND  
OTHER PERSONS OR SPOUSES  
CLAI, SPOUSE OF GERALDINE  
FRANKLIN a/k/a VIRGINIA  
GERALDINE SHIELDS  
FRANKLIN, BENJAMIN  
FRANKLIN,  
Defendants.**

NOTICE IS HEREBY GIVEN pursuant to an Order Resetting Foreclosure Sale filed March 20, 2014, and entered in Case No. 51-2010-CA-006797-WS-J3 of the Circuit Court of the 6th Judicial Circuit, in and for PASCO County, Florida, wherein WELLS FARGO BANK, N.A. is the Plaintiff and HEIRS, DEVISEES, GRANTEES, CREDITORS AND OTHER PERSONS OR SPOUSES CLAI, SPOUSE OF GERALDINE FRANKLIN a/k/a VIRGINIA GERALDINE SHIELDS FRANKLIN, BENJAMIN FRANKLIN, are the Defendants, the Clerk of the Court will sell to the highest bidder for cash on APRIL 24, 2014, at 11:00 A.M., at www.pasco.realforeclose.com, the following described property as set forth in said Summary Final Judgment lying and being situate in PASCO County, Florida, to wit:

The North 1/2 of Lot 9, all of Lot 18 and the North 75 feet of Lot 11, less the East 20 feet thereof, Block 157, A REVISED PLAT OF THE TOWN OF NEW PORT RICHEY, according to the map or plat thereof, as recorded in Plat Book 4, Page 49, of the Public Records of Pasco County, Florida.

a/k/a 5834 Grand Blvd. New Port Richey, Florida 34652  
ANY PERSON CLAIMING AN INTEREST IN THE SURPLUS FROM

THE SALE, IF ANY, OTHER THAN THE PROPERTY OWNER AS OF THE DATE OF THE LIS PENDENS MUST FILE A CLAIM WITHIN 60 DAYS AFTER THE SALE. THE CLERK SHALL RECEIVE A SERVICE CHARGE OF UP TO \$70 FOR SERVICES IN MAKING, RECORDING, AND CERTIFYING THE SALE AND TITLE THAT SHALL BE ASSESSED AS COSTS. THE COURT, IN ITS DISCRETION, MAY ENLARGE THE TIME OF THE SALE. NOTICE OF THE CHANGED TIME OF SALE SHALL BE PUBLISHED AS PROVIDED HEREIN.

If you are a person with a disability who needs any accommodation in order to participate in this proceeding, you are entitled, at no cost to you, to the provision of certain assistance. Please contact the Public Information Dept., Pasco County Government Center, 7530 Little Rd., New Port Richey, FL 34654; (727) 847-8110 (V) in New Port Richey; (352) 521-4274, ext 8110 (V) in Dade City, at least 7 days before your scheduled court appearance, or immediately upon receiving this notification if the time before the scheduled appearance is less than 7 days; if you are hearing impaired call 711.

The court does not provide transportation and cannot accommodate for this service. Persons with disabilities needing transportation to court should contact their local public transportation providers for information regarding transportation services.

DATED this 26th day of March, 2014.

By: Michael J. Eisler, Esq.  
Fla Bar No.: 500615  
Arnold M. Straus Jr. Esq  
Fla Bar No.: 275328  
Email:  
service.pines@strauseisler.com  
STRAUS & EISLER, P.A.  
Attorneys for Plaintiff  
10081 Pines Blvd, Suite C  
Pembroke Pines, FL 33024  
954-431-2000  
April 4, 11, 2014 14-01937P

FIRST INSERTION

**NOTICE OF FORECLOSURE SALE IN THE CIRCUIT COURT OF THE SIXTH JUDICIAL CIRCUIT IN AND FOR PASCO COUNTY, FLORIDA CIVIL ACTION**  
**CASE NO.: 51-2012-CA-003571 WS DIVISION: J3**  
**JAMES B. NUTTER & COMPANY, Plaintiff, vs.**  
**ELLIS M. HAUGER, et al, Defendant(s).**  
 NOTICE IS HEREBY GIVEN pursuant to a Final Judgment of Mortgage Foreclosure dated March 24, 2014 and entered in Case No. 51-2012-CA-003571 WS of the Circuit Court of the SIXTH Judicial Circuit in and for PASCO County, Florida wherein JAMES B. NUTTER & COMPANY is the Plaintiff and ELLIS M HAUGER; UNITED STATES OF AMERICA ON BEHALF OF U.S. DEPARTMENT OF HOUSING AND URBAN DEVELOPMENT; TIMBER OAKS COMMUNITY SERVICES ASSOCIATION, INC.; are the Defendants, The Clerk will sell to the highest and best bidder for cash at WWW.PASCO.REALFORECLOSE.COM IN ACCORDANCE WITH CHAPTER 45 FLORIDA STATUTES at 11:00AM, on 05/06/2014, the following described property as set forth in said Final Judgment:  
 LOT 4 OF TIMBER OAKS TRACT 13 PHASE 2, ACCORDING TO THE PLAT THEREOF AS RECORDED IN PLAT BOOK 16, PAGE(S) 117 AND 118, OF THE PUBLIC RE-

**CORDS OF PASCO COUNTY, FLORIDA.**  
**A/K/A 8514 ELGIN DRIVE, PORT RICHEY, FL 34668**  
 Any person claiming an interest in the surplus from the sale, if any, other than the property owner as of the date of the Lis Pendens must file a claim within sixty (60) days after the sale.  
**\*\*See Americans with Disabilities Act**  
 \*If you are a person with a disability who needs an accommodation in order to participate in this proceeding, you are entitled, at no cost to you, to the provision of certain assistance. Please contact: Public Information Dept., Pasco County Government Center 7530 Little Rd. New Port Richey, FL 34654 Phone: 727.847.8110 (voice) in New Port Richey 352.521.4274, ext 8110 (voice) in Dade City Or 711 for the hearing impaired  
 Contact should be initiated at least seven days before the scheduled court appearance, or immediately upon receiving this notification if the time before the scheduled appearance is less than seven days.  
 By: J. Bennett Kitterman  
 Florida Bar No. 98636  
 Ronald R Wolfe & Associates, P.L.  
 P.O. Box 25018  
 Tampa, Florida 33622-5018 (813) 251-4766  
 (813) 251-1541 Fax  
 F12006540  
 April 4, 11, 2014 14-01942P

FIRST INSERTION

**NOTICE OF SALE IN THE CIRCUIT COURT OF THE SIXTH JUDICIAL CIRCUIT IN AND FOR PASCO COUNTY, FLORIDA CIVIL DIVISION**  
**Case #: 51-2011-CA-000757-WS J3 DIVISION: J3**  
**Federal National Mortgage Association ("FNMA") Plaintiff, vs.-**  
**Drita Haziri and Islajam Haziri, Wife and Husband; Bank Of America, National Association; Unknown Tenants in Possession #1; Unknown Tenants in Possession #2; If living, and all Unknown Parties claiming by, through, under and against the above named Defendant(s) who are not known to be dead or alive, whether said Unknown Parties may claim an interest as Spouse, Heirs, devisees, Grantees, or Other Claimants Defendant(s).**  
 NOTICE IS HEREBY GIVEN pursuant to a Final Judgment, entered in Civil Case No. 51-2011-CA-000757-WS J3 of the Circuit Court of the 6th Judicial Circuit in and for Pasco County, Florida, wherein Federal National Mortgage Association, Plaintiff and Drita Haziri and Islajam Haziri, Wife and Husband are defendant(s), I, Clerk of Court, Paula S. O'Neil, will sell to the highest and best bidder for cash in an online sale accessed through the Clerk's website at www.pasco.realforeclose.com, at 11:00 a.m. on May 12, 2014, the following described property as set

forth in said Final Judgment, to-wit: LOT 243, OF BROWN ACRES UNIT SEVEN, ACCORDING TO THE MAP OR PLAT THEREOF, AS RECORDED IN PLAT BOOK 11, PAGE 57, OF THE PUBLIC RECORDS OF PASCO COUNTY, FLORIDA.  
 ANY PERSON CLAIMING AN INTEREST IN THE SURPLUS FROM THE SALE, IF ANY, OTHER THAN THE PROPERTY OWNER AS OF THE DATE OF THE LIS PENDENS MUST FILE A CLAIM WITHIN 60 DAYS AFTER THE SALE.  
 If you are a person with a disability who needs any accommodation in order to participate in this proceeding, you are entitled, at no cost to you, to the provision of certain assistance. Please contact the ADA Coordinator:14250 49th Street North, Clearwater, Florida 33762 (727) 453-7163 at least 7 days before your scheduled court appearance, or immediately upon receiving this notification of the time before the scheduled appearance is less than 7 days. If you are hearing or voice impaired, call 711.  
 Submitted By:  
 ATTORNEY FOR PLAINTIFF:  
 SHAPIRO, FISHMAN & GACHE, LLP  
 2424 North Federal Highway,  
 Suite 360  
 Boca Raton, Florida 33431  
 (561) 998-6700  
 (561) 998-6707  
 10-179448 FCO1 WCC  
 April 4, 11, 2014 14-01953P

FIRST INSERTION

**NOTICE OF FORECLOSURE SALE IN THE CIRCUIT COURT IN AND FOR PASCO COUNTY, FLORIDA**  
**CASE NO:**  
**2013CA002599CAAXWS**  
**JPMORGAN CHASE BANK, NATIONAL ASSOCIATION Plaintiff, vs.**  
**INEZ L. DIAZ A/K/A INES DIAZ A/K/A INES L. MOYA; UNKNOWN SPOUSE OF INEZ L. DIAZ A/K/A INES DIAZ A/K/A INES L. MOYA; UNKNOWN TENANT I; UNKNOWN TENANT II; VICTOR M. DIAZ A/K/A VICTOR DIAZ; CLERK OF THE CIRCUIT COURT IN AND FOR PASCO COUNTY, and any unknown heirs, devisees, grantees, creditors, and other unknown persons or unknown spouses claiming by, through and under any of the above-named Defendants, Defendants.**  
 NOTICE is hereby given that the Clerk of the Circuit Court of Pasco County, Florida, will on the 22nd day of April, 2014, 11:00AM online at www.pasco.realforeclose.com, offer for sale and sell at public outcry to the highest and best bidder for cash, the following-described property situate in Pasco County, Florida:  
 Lot 411, BEAR CREEK, UNIT 3, according to the Plat thereof as recorded in Plat Book 22, pages 34 and 35, Public Records of Pasco County, Florida,  
 pursuant to the Final Judgment en-

tered in a case pending in said Court, the style of which is indicated above.  
 Any person or entity claiming an interest in the surplus, if any, resulting from the foreclosure sale, other than the property owner as of the date of the Lis Pendens, must file a claim on same with the Clerk of Court within 60 days after the foreclosure sale.  
 AMERICANS WITH DISABILITIES ACT. If you are a person with a disability who needs any accommodation in order to participate in this proceeding, you are entitled, at no cost to you, to the provision of certain assistance. Please contact the Human Rights Office, 400 S. Ft. Harrison Ave., Ste. 500 Clearwater, FL 33756, (727) 464-4880(V) at least 7 days before your scheduled court appearance, or immediately upon receiving this notification if the time before the scheduled appearance is less than 7 days; if you are hearing impaired call 711.  
 DATED this 28 day of March, 2014.  
 Chris Bertels, Esquire  
 Florida Bar No: 98267  
 Charles A. Muniz, Esquire  
 Florida Bar No: 100775  
 BUTLER & HOSCH, P.A.  
 3185 South Conway Road, Suite E  
 Orlando, Florida 32812  
 Telephone: (407) 381-5200  
 Fax: (407) 381-5577  
 cm100775@butlerandhosch.com  
 FLPlendings@butlerandhosch.com  
 B&H # 289787  
 April 4, 11, 2014 14-01963P

FIRST INSERTION

**NOTICE OF SALE IN THE CIRCUIT CIVIL COURT OF THE SIXTH JUDICIAL CIRCUIT OF FLORIDA, IN AND FOR PASCO COUNTY CIVIL DIVISION**  
**Case No.**  
**51-2013-CA-003201WS Division J6**  
**CENLAR FSB Plaintiff, vs.**  
**STEVE D. LUIKART A/K/A STEPHEN DAVID LUIKART A/K/A STEVEN D. HEIDT, CYNTHIA A. CHENARD A/K/A CYNTHIA ANNE CHENARD A/K/A CYNTHIA ANNE CHENARD, BRIARWOODS HOMEOWNERS ASSOCIATION, INC., AND UNKNOWN TENANTS/OWNERS, Defendants.**  
 Notice is hereby given, pursuant to Final Judgment of Foreclosure for Plaintiff entered in this cause on March 7, 2014, in the Circuit Court of Pasco County, Florida, Paula O'Neil, Clerk of the Circuit Court, will sell the property situated in Pasco County, Florida described as:  
 LOT 38, BRIARWOODS, PHASE I, ACCORDING TO THE PLAT THEREOF AS RECORDED IN PLAT BOOK 19, PAGE(S) 8 THROUGH 13, OF THE PUBLIC RECORDS OF PASCO COUNTY, FLORIDA.  
 and commonly known as: 10134 BRIAR CIR, HUDSON, FL 34667; including the building, appurtenances, and fixtures located therein, at public sale, to the highest and best bidder, for cash, www.pasco.real-

foreclose.com, on April 22, 2014 at 11am.  
 Any persons claiming an interest in the surplus from the sale, if any, other than the property owner as of the date of the lis pendens must file a claim within 60 days after the sale.  
 If you are a person with a disability who needs any accommodation in order to participate in this proceeding, you are entitled, at no cost to you, to the provision of certain assistance. Please contact the Public Information Dept., Pasco County Government Center, 7530 Little Rd., New Port Richey, FL 34654; (727) 847-8110 (V) in New Port Richey; (352) 521-4274, ext 8110 (V) in Dade City, at least 7 days before your scheduled court appearance, or immediately upon receiving this notification if the time before the scheduled appearance is less than 7 days; if you are hearing impaired call 711. The court does not provide transportation and cannot accommodate for this service. Persons with disabilities needing transportation to court should contact their local public transportation providers for information regarding transportation services.  
 By: David J. Melvin  
 Attorney for Plaintiff  
 Invoice to:  
 David J. Melvin  
 (813) 229-0900 x1327  
 Kass Shuler, P.A.  
 P.O. Box 800  
 Tampa, FL 33601-0800  
 ForeclosureService@kasslaw.com  
 327470/1226304/  
 April 4, 11, 2014 14-01965P

FIRST INSERTION

**NOTICE OF SALE IN THE CIRCUIT CIVIL COURT OF THE SIXTH JUDICIAL CIRCUIT OF FLORIDA, IN AND FOR PASCO COUNTY CIVIL DIVISION**  
**Case No. 51-2012-CA-004166WS Division J3**  
**US BANK NATIONAL ASSOCIATION, AS TRUSTEE FOR STRUCTURED ASSET SECURITIES CORPORATION MORTGAGE PASS-THROUGH CERTIFICATES, SERIES 2007-EQ1 Plaintiff, vs.**  
**RAUL SANTIAGO, ANNA SANTIAGO, MORTGAGE ELECTRONIC REGISTRATION SYSTEMS, INC. AS NOMINEE FOR EQUIFIRST CORPORATION, AND UNKNOWN TENANTS/OWNERS, Defendants.**  
 Notice is hereby given, pursuant to Final Judgment of Foreclosure for Plaintiff entered in this cause on February 26, 2014, in the Circuit Court of Pasco County, Florida, Paula O'Neil, Clerk of the Circuit Court, will sell the property situated in Pasco County, Florida described as:  
 LOT 184, CREST RIDGE GARDENS UNIT TWO AS PER PLAT THEREOF, RECORDED IN PLAT BOOK 8, PAGE 3, OF THE PUBLIC RECORDS OF PASCO COUNTY, FLORIDA  
 and commonly known as: 1051 CLAIRBORNE STREET, HOLIDAY, FL 34690; including the building, appurtenances, and fixtures located therein, at public sale, to the highest and best bidder, for cash, www.pasco.

realforeclose.com, on April 23, 2014 at 11am.  
 Any persons claiming an interest in the surplus from the sale, if any, other than the property owner as of the date of the lis pendens must file a claim within 60 days after the sale.  
 If you are a person with a disability who needs any accommodation in order to participate in this proceeding, you are entitled, at no cost to you, to the provision of certain assistance. Please contact the Public Information Dept., Pasco County Government Center, 7530 Little Rd., New Port Richey, FL 34654; (727) 847-8110 (V) in New Port Richey; (352) 521-4274, ext 8110 (V) in Dade City, at least 7 days before your scheduled court appearance, or immediately upon receiving this notification if the time before the scheduled appearance is less than 7 days; if you are hearing impaired call 711. The court does not provide transportation and cannot accommodate for this service. Persons with disabilities needing transportation to court should contact their local public transportation providers for information regarding transportation services.  
 By: Kari D. Marsland-Pettit  
 Attorney for Plaintiff  
 Invoice to:  
 Kari D. Marsland-Pettit  
 (813) 229-0900 x1509/1359  
 Kass Shuler, P.A.  
 P.O. Box 800  
 Tampa, FL 33601-0800  
 ForeclosureService@kasslaw.com  
 327611/1124946/  
 April 4, 11, 2014 14-01977P

FIRST INSERTION

**NOTICE OF SALE PURSUANT TO CHAPTER 45 IN THE CIRCUIT COURT OF THE SIXTH JUDICIAL CIRCUIT IN AND FOR PASCO COUNTY, FLORIDA CIVIL ACTION**  
**CASE NO.:**  
**51-2013-CA-000500-CAAX-WS**  
**JPMORGAN CHASE BANK, NATIONAL ASSOCIATION, Plaintiff, vs.**  
**MARTINEZ, ALEXIS V. et al, Defendant(s).**  
 NOTICE IS HEREBY GIVEN Pursuant to a Final Judgment of Foreclosure dated February 28, 2014, and entered in Case No. 51-2013-CA-000500-CAAX-WS of the Circuit Court of the Sixth Judicial Circuit in and for Pasco County, Florida in which JPMorgan Chase Bank, National Association, is the Plaintiff and Alexis Victor Martinez, Marisol Reyes, are defendants, the Pasco County Clerk of the Circuit Court will sell to the highest and best bidder for cash in/on held online www.pasco.realforeclose.com: in Pasco County, Florida, Pasco County, Florida at 11:00AM on the 28th day of April, 2014, the following described property as set forth in said Final Judgment of Foreclosure:  
 LOT 96, SAN CLEMENTE EAST UNIT THREE, ACCORDING TO THE MAP OR PLAT THEREOF, AS RECORDED IN PLAT BOOK 10, PAGE 120, PUBLIC RECORDS OF PASCO COUNTY, FLORIDA.  
 6932 ALTAVISTA ST PORT RICHEY FL 34668-3865  
 Any person claiming an interest in the surplus from the sale, if any, other than the property owner as of the date of the

Lis Pendens must file a claim within 60 days after the sale.  
 If you are a person with a disability who needs an accommodation in order to participate in this proceeding, you are entitled, at no cost to you, to the provision of certain assistance. Please contact:  
 Public Information Dept., Pasco County Government Center 7530 Little Rd. New Port Richey, FL 34654 Phone: 727.847.8110 (voice) in New Port Richey 352.521.4274, ext 8110 (voice) in Dade City Or 711 for the hearing impaired  
 Contact should be initiated at least seven days before the scheduled court appearance, or immediately upon receiving this notification if the time before the scheduled appearance is less than seven days.  
 The court does not provide transportation and cannot accommodate such requests. Persons with disabilities needing transportation to court should contact their local public transportation providers for information regarding transportation services.  
 Dated in Hillsborough County, Florida, this 1st day of April, 2014  
 /s/ Erik Del'Etoile  
 Erik Del'Etoile, Esq.  
 FL Bar # 71675  
 Albertelli Law  
 Attorney for Plaintiff  
 P.O. Box 23028  
 Tampa, FL 33623  
 (813) 221-4743  
 (813) 221-9171 facsimile  
 eService:  
 servealaw@albertellilaw.com  
 JR- 014472F01  
 April 4, 11, 2014 14-02036P

FIRST INSERTION

**NOTICE OF FORECLOSURE SALE IN THE CIRCUIT COURT OF THE SIXTH JUDICIAL CIRCUIT IN AND FOR PASCO COUNTY, FLORIDA CIVIL DIVISION**  
**Case No.:**  
**51-2011-CA-004454-XXXX-ES Division: J1**  
**NATIONSTAR MORTGAGE, LLC, Plaintiff, vs.**  
**CARY OVERSTREET; ET. AL, Defendants.**  
 NOTICE IS HEREBY GIVEN pursuant to a Final Judgment dated March 12, 2013, entered in Civil Case No.: 51-2011-CA-004454-XXXX-ES, Division; J1, of the Circuit Court of the SIXTH Judicial Circuit in and for PASCO COUNTY, Florida, wherein NATIONSTAR MORTGAGE, LLC, is Plaintiff, and CARY OVERSTREET; JANITH OVERSTREET; LEXINGTON OAKS OF PASCO COUNTY HOMEOWNERS ASSOCIATION, INC.; UNKNOWN TENANT #1; UNKNOWN TENANT #2; ALL OTHER UNKNOWN PARTIES CLAIMING INTERESTS BY, THROUGH, UNDER, AND AGAINST A NAMED DEFENDANT(S) WHO ARE NOT KNOWN TO BE DEAD OR ALIVE, WHETHER SAME UNKNOWN PARTIES MAY CLAIM AN INTEREST AS SPOUSES, HEIRS, DEVISEES, GRANTEEES, OR OTHER CLAIMANTS, are Defendants.  
 PAULA S. O'NEIL, Clerk of the Court, will sell to the highest bidder for cash at 11:00 a.m. online at www.pasco.realforeclose.com on the 16th day of April, 2014 the following described real property as set forth in said Final Judgment, to wit:  
 LOT 10, BLOCK 22, LEXINGTON OAKS VILLAGES 18, 19 & 20, ACCORDING TO THE

PLAT THEREOF, AS RECORDED IN PLAT BOOK 45, PAGES 80 THROUGH 86, OF THE PUBLIC RECORDS OF PASCO COUNTY, FLORIDA.  
 If you are a person claiming a right to funds remaining after the sale, you must file a claim with the clerk no later than 60 days after the sale. If you fail to file a claim you will not be entitled to any remaining funds. After 60 days, only the owner of record as of the date of the lis pendens may claim the surplus.  
 If you are a person with a disability who needs an accommodation in order to participate in this proceeding, you are entitled, at no cost to you, to the provision of certain assistance. Please contact: Public Information Dept., Pasco County Government Center, 7530 Little Rd., New Port Richey, FL 34654. Phone: 727.847.8110 (voice) in New Port Richey 352.521.4274, ext 8110 (voice) in Dade City or 711 for the hearing impaired. Contact should be initiated at least seven days before the scheduled court appearance, or immediately upon receiving this notification if the time before the scheduled appearance is less than seven days  
 Dated this 20 day of March, 2014.  
 /s/ Joshua Sabet  
 By: Joshua Sabet, Esquire  
 Fla. Bar No.: 85356  
 Primary Email:  
 JSabet@ErwLaw.com  
 Secondary Email:  
 docservice@ErwLaw.com  
 Attorney for Plaintiff:  
 Elizabeth R. Wellborn, P.A.  
 350 Jim Moran Blvd. Suite 100  
 Deerfield Beach, FL 33442  
 Telephone: (954) 354-3544  
 Facsimile: (954) 354-3545  
 File # 1137-41165  
 April 4, 11, 2014 14-01930P

FIRST INSERTION

**NOTICE OF RESCHEDULED SALE IN THE CIRCUIT COURT OF THE SIXTH JUDICIAL CIRCUIT IN AND FOR PASCO COUNTY, FLORIDA CIVIL ACTION**  
**CASE NO.:**  
**51-2011-CA-002110-CAAX-ES**  
**WELLS FARGO BANK, NA, Plaintiff, vs.**  
**LA RUE SR., RONALD et al, Defendant(s).**  
 NOTICE IS HEREBY GIVEN Pursuant to an Order Rescheduling Foreclosure Sale dated March 4, 2014, and entered in Case No. 51-2011-CA-002110-CAAX-ES of the Circuit Court of the Sixth Judicial Circuit in and for Pasco County, Florida in which Wells Fargo Bank, NA, is the Plaintiff and Elizabeth E. La Rue, Ronald W. La Rue, Sr., Tenant #1 n/k/a Michelle Herick, are defendants, the Pasco County Clerk of the Circuit Court will sell to the highest and best bidder for cash held online www.pasco.realforeclose.com: in Pasco County, Florida at 11:00AM on the 21st day of April, 2014, the following described property as set forth in said Final Judgment of Foreclosure: TRACT #187 (ONE HUNDRED EIGHTY-SEVEN)-WILLIAMS DOUBLE BRANCH ESTATES A SUBDIVISION IN SECTION 33, TOWNSHIP 25 SOUTH, RANGE 20 EAST, PASCO COUNTY, FLORIDA, AS PER MAP OR PLAT THEREOF RECORDED IN PLAT BOOK 12, AT PAGES 106 THROUGH 112 OF THE PUBLIC RECORDS OF PASCO COUNTY, FLORIDA. TOGETHER WITH A 1995 CRES MOBILE HOME, I.D. # FLA146M9389A & FLA146M9389B, AS PART OF THE REAL PROPERTY HEREIN CONVEYED.  
 30127 EASTPORT DRIVE,

ZEPHYRHILLS, FL 33544-3018  
 Any person claiming an interest in the surplus from the sale, if any, other than the property owner as of the date of the Lis Pendens must file a claim within 60 days after the sale.  
 If you are a person with a disability who needs an accommodation in order to participate in this proceeding, you are entitled, at no cost to you, to the provision of certain assistance. Please contact:  
 Public Information Dept., Pasco County Government Center 7530 Little Rd. New Port Richey, FL 34654 Phone: 727.847.8110 (voice) in New Port Richey 352.521.4274, ext 8110 (voice) in Dade City Or 711 for the hearing impaired  
 Contact should be initiated at least seven days before the scheduled court appearance, or immediately upon receiving this notification if the time before the scheduled appearance is less than seven days.  
 The court does not provide transportation and cannot accommodate such requests. Persons with disabilities needing transportation to court should contact their local public transportation providers for information regarding transportation services.  
 Dated in Hillsborough County, Florida, this 26th day of March, 2014  
 /s/ Erik Del'Etoile  
 Erik Del'Etoile, Esq.  
 FL Bar # 71675  
 Albertelli Law  
 Attorney for Plaintiff  
 P.O. Box 23028  
 Tampa, FL 33623  
 (813) 221-4743  
 (813) 221-9171 facsimile  
 eService:  
 servealaw@albertellilaw.com  
 BM- 11-77164  
 April 4, 11, 2014 14-01946P

FIRST INSERTION

**NOTICE OF SALE IN THE CIRCUIT COURT OF THE SIXTH JUDICIAL CIRCUIT IN AND FOR PASCO COUNTY, FLORIDA CIVIL DIVISION**  
**Case #: 51-2011-CA-006006-ES (J1) DIVISION: J1**  
**JPMorgan Chase Bank, National Association Plaintiff, vs.-**  
**James J. Laliberte; Unknown Parties in Possession #1; Unknown Parties in Possession #2 Defendant(s).**  
 NOTICE IS HEREBY GIVEN pursuant to a Final Judgment, entered in Civil Case No. 51-2011-CA-006006-ES (J1) of the Circuit Court of the 6th Judicial Circuit in and for Pasco County, Florida, wherein JPMorgan Chase Bank, National Association, Plaintiff and James J. Laliberte are defendant(s), I, Clerk of Court, Paula S. O'Neil, will sell to the highest and best bidder for cash in an online sale accessed through the Clerk's website at www.pasco.realforeclose.com, at 11:00 a.m. on May 5, 2014, the following described property as set forth in said Final Judgment, to-wit:  
 COMMENCING AT THE NORTHEAST CORNER OF THE NORTHEAST 1/4 OF THE NORTHEAST 1/4 OF SECTION 35, TOWNSHIP 26 SOUTH, RANGE 18 EAST, PASCO COUNTY, FLORIDA; RUN THENCE WEST 155.0 FEET; THENCE SOUTH 20.0 FEET FOR A POINT OF BEGINNING; THENCE RUN SOUTH 100.0 FEET; THENCE WEST 88.3 FEET; THENCE NORTH 100.0 FEET; THENCE EAST 88.3 FEET TO THE POINT OF

BEGINNING. FOR THE PURPOSES OF THIS DESCRIPTION, THE NORTH BOUNDARY OF SAID NORTHEAST 1/4 OF THE NORTHEAST 1/4 IS ASSUMED AS RUNNING EAST AND WEST. TOGETHER WITH THAT CERTAIN MANUFACTURED HOME, YEAR: 1992, MAKE: MERITT LIVESTOCK TRAILER, VIN#: FLHML-CP3977676A AND VIN#: FLHMLCP3977676B, WHICH IS AFFIXED THERETO ANY PERSON CLAIMING AN INTEREST IN THE SURPLUS FROM THE SALE, IF ANY, OTHER THAN THE PROPERTY OWNER AS OF THE DATE OF THE LIS PENDENS MUST FILE A CLAIM WITHIN 60 DAYS AFTER THE SALE.  
 If you are a person with a disability who needs any accommodation in order to participate in this proceeding, you are entitled, at no cost to you, to the provision of certain assistance. Please contact the ADA Coordinator:14250 49th Street North, Clearwater, Florida 33762 (727) 453-7163 at least 7 days before your scheduled court appearance, or immediately upon receiving this notification of the time before the scheduled appearance is less than 7 days. If you are hearing or voice impaired, call 711.  
 Submitted By:  
 ATTORNEY FOR PLAINTIFF:  
 SHAPIRO, FISHMAN & GACHÉ, LLP  
 2424 North Federal Highway,  
 Suite 360  
 Boca Raton, Florida 33431  
 (561) 998-6700  
 (561) 998-6707  
 BM- 11-229106 FCO1 CHE  
 April 4, 11, 2014 14-01952P

## FIRST INSERTION

NOTICE OF SALE IN THE COUNTY COURT OF THE SIXTH JUDICIAL CIRCUIT IN AND FOR PASCO COUNTY, FLORIDA CIVIL DIVISION

**CASE NO. 51-2011-CC-1500-ES/D ASBEL CREEK ASSOCIATION, INC., Plaintiff, v. AMEER DAVIS AND TRACY DAVIS, AND JOHN DOE AND JANE DOE AND ALL OTHER PERSONS IN POSSESSION OF THE SUBJECT REAL PROPERTY WHOSE NAMES ARE UNCERTAIN Defendants.**

NOTICE IS HEREBY GIVEN that, pursuant to the Summary Final Judgment in this cause, in the County Court of Pasco County, Florida, I will sell all the property situated in Pasco County, Florida described as:

Lot 49, Block B, Asbel Creek Phase Two, according to the map or plat thereof as recorded in Plat Book 54, Pages 50-59, of the Public Records of Pasco County, Florida. With the following street address: 10129 Perthshire Circle, Land O' Lakes, Florida, 34638. Property Address: 10129 Perthshire Circle, Land O' Lakes, Florida, 34638.

at public sale, to the highest and best bidder, for cash, at www.pasco.realforeclose.com, at 11:00 A.M. on June 23, 2014.

Any person claiming an interest in the surplus from the sale, if any, other

than the property owner as of the date of the lis pendens must file a claim within 60 days after the sale.

If you are a person with a disability who needs any accommodation in order to participate in this proceeding, you are entitled, at no cost to you, to the provision of certain assistance. Please contact the Public Information Dept., Pasco County Government Center, 7530 Little Rd., New Port Richey, FL 34654; (727) 847-8110 (V) in New Port Richey; (352) 521-4274, ext 8110 (V) in Dade City, at least 7 days before your scheduled court appearance, or immediately upon receiving this notification if the time before the scheduled appearance is less than 7 days; if you are hearing impaired call 711. The court does not provide transportation and cannot accommodate for this service. Persons with disabilities needing transportation to court should contact their local public transportation providers for information regarding transportation services.

Dated this 26th day of March, 2014.

PAULA S. O'NEIL  
CLERK OF THE CIRCUIT COURT  
s/ Joseph R. Cianfrone  
Joseph R. Cianfrone  
(Joe@attorneyjoe.com)  
Bar Number 248525

Attorney for Plaintiff Asbel Creek Association, Inc.

1964 Bayshore Boulevard, Suite A  
Dunedin, Florida 34698  
Telephone: (727) 738-1100

April 4, 11, 2014 14-01932P

NOTICE OF FORECLOSURE SALE IN THE CIRCUIT COURT OF THE SIXTH JUDICIAL CIRCUIT, IN AND FOR PASCO COUNTY, FLORIDA CIVIL DIVISION

**CASE NO.: 51-2012-CA-007497-XXXX-WS JPMORGAN CHASE BANK, NATIONAL ASSOCIATION Plaintiff, vs. JOHN LOPEZ, et al Defendants.**

NOTICE IS HEREBY GIVEN pursuant to a Summary Final Judgment of foreclosure dated December 18, 2013, and entered in Case No. 51-2012-CA-007497-XXXX-WS of the Circuit Court of the SIXTH Judicial Circuit in and for PASCO COUNTY, Florida, wherein JPMORGAN CHASE BANK, NATIONAL ASSOCIATION, is Plaintiff, and JOHN LOPEZ, et al are Defendants, the clerk will sell to the highest and best bidder for cash, beginning at 11:00 AM at www.pasco.realforeclose.com, in accordance with Chapter 45, Florida Statutes, on the 22 day of April, 2014, the following described property as set forth in said Summary Final Judgment, to wit:

Lot 179, The Meadows, according to the map or plat thereof, as recorded in Plat Book 14, at Page 109, of the Public records of Pasco County, Florida.

Any person claiming an interest in the surplus funds from the sale, if any, other than the property owner as of the date of the lis pendens must file a claim within 60 days after the sale.

If you are a person with a disability who needs any accommodation in order to participate in this proceeding, you are entitled, at no cost to you, to the provision of certain assistance. Please contact the Public Information Dept., Pasco County Government Center, 7530 Little Rd., New Port Richey, FL 34654; (727) 847-8110 (V) in New Port Richey; (352) 521-4274, ext 8110 (V) in Dade City, at least 7 days before your scheduled court appearance, or immediately upon receiving this notification if the time before the scheduled appearance is less than seven (7) days; if you are hearing or voice impaired, call 711.

The court does not provide transportation and cannot accommodate for this service. Persons with disabilities needing transportation to court should contact their local public transportation providers for information regarding transportation services.

Dated: March 26, 2014

By: /s/ Heather J. Koch  
Phelan Hallinan, PLC  
Heather J. Koch, Esq.,  
Florida Bar No. 89107  
Emilio R. Lenzi, Esq.,  
Florida Bar No. 0668273

Phelan Hallinan, PLC  
Attorneys for Plaintiff  
2727 West Cypress Creek Road  
Ft. Lauderdale, FL 33309  
Tel: 954-462-7000  
Fax: 954-462-7001  
Service by email:  
FL.Service@PhelanHallinan.com  
PH # 35378  
April 4, 11, 2014 14-01940P

## FIRST INSERTION

NOTICE OF FORECLOSURE SALE IN THE CIRCUIT COURT IN AND FOR PASCO COUNTY, FLORIDA

**CASE NO.: 51-2013-CA-000831-WS-J2 JPMORGAN CHASE BANK, NATIONAL ASSOCIATION Plaintiff, vs.**

**THAMA SMIELESKI; ALL UNKNOWN HEIRS, CREDITORS, DEVEISEES, BENEFICIARIES, GRANTEEES, ASSIGNEES, LIENORS, TRUSTEES, AND ALL PARTIES CLAIM AN INTEREST BY, THROUGH, UNDER OR AGAINST JOHN P. SMIELESKI A/K/A JOHN SMIELESKI; UNKNOWN SPOUSE OF THAMA SMIELESKI; UNKNOWN TENANT I; UNKNOWN TENANT II, and any unknown heirs, devisees, grantees, creditors, and other unknown persons or unknown spouses claiming by, through and under any of the above-named Defendants, Defendants.**

NOTICE is hereby given that the Clerk of the Circuit Court of Pasco County, Florida, will 22nd day of April, 2014, at 11:00AM online at www.pasco.realforeclose.com, offer for sale and sell at public outcry to the highest and best bidder for cash, the following-described property situate in Pasco County, Florida:

LOT 205, JASMINE HEIGHTS UNIT FIVE, ACCORDING TO PLAT THEREOF RECORDED IN PLAT BOOK 7, PAGE 14, PUBLIC RECORDS OF PASCO

COUNTY, FLORIDA. pursuant to the Final Judgment entered in a case pending in said Court, the style of which is indicated above.

Any person or entity claiming an interest in the surplus, if any, resulting from the foreclosure sale, other than the property owner as of the date of the Lis Pendens, must file a claim on same with the Clerk of Court within 60 days after the foreclosure sale.

AMERICANS WITH DISABILITIES ACT. If you are a person with a disability who needs any accommodation in order to participate in this proceeding, you are entitled, at no cost to you, to the provision of certain assistance. Please contact the Human Rights Office, 400 S. Ft. Harrison Ave., Ste. 500 Clearwater, FL 33756, (727) 464-4880(V) at least 7 days before your scheduled court appearance, or immediately upon receiving this notification if the time before the scheduled appearance is less than 7 days; if you are hearing impaired call 711.

DATED this 28 day of March, 2014.  
Chris Bertels, Esquire  
Florida Bar No: 98267  
Charles A. Muniz, Esquire  
Florida Bar No: 100775

BUTLER & HOSCH, P.A.  
3185 South Conway Road, Suite E  
Orlando, Florida 32812  
Telephone: (407) 381-5200  
Fax: (407) 381-5577  
cm100775@butlerandhosch.com  
FLPleadings@butlerandhosch.com  
B&H # 288175  
April 4, 11, 2014 14-01962P

## FIRST INSERTION

NOTICE OF RESCHEDULED SALE IN THE CIRCUIT COURT OF THE SIXTH JUDICIAL CIRCUIT IN AND FOR PASCO COUNTY, FLORIDA CIVIL ACTION

**CASE NO.: 51-2012-CA-000586-CAAX-WS WELLS FARGO BANK, NA, Plaintiff, vs. YOUNG, BRANDON et al, Defendant(s).**

NOTICE IS HEREBY GIVEN Pursuant to an Order Rescheduling Foreclosure Sale dated on or about March 4, 2014, and entered in Case No. 51-2012-CA-000586-CAAX-WS of the Circuit Court of the Sixth Judicial Circuit in and for Pasco County, Florida in which Wells Fargo Bank, NA, is the Plaintiff and Brandon M. Young, Tenant #1, Tenant #2, The Unknown Spouse of Brandon M. Young, are defendants, the Pasco County Clerk of the Circuit Court will sell to the highest and best bidder for cash held online www.pasco.realforeclose.com: in Pasco County, Florida, Pasco County, Florida at 11:00AM on the 22nd day of April 2014, the following described property as set forth in said Final Judgment of Foreclosure:

LOT 322, TANGLEWOOD TERRACE UNIT TWO, ACCORDING TO THE PLAT THEREOF RECORDED IN PLAT BOOK 11, PAGE 84 AND 85 OF THE PUBLIC RECORDS OF PASCO COUNTY, FLORIDA 6035 1ST AVE, NEW PORT RICHEY, FL 34653-5101

Any person claiming an interest in the surplus from the sale, if any, other than the property owner as of the date of the

Lis Pendens must file a claim within 60 days after the sale.

If you are a person with a disability who needs any accommodation in order to participate in this proceeding, you are entitled, at no cost to you, to the provision of certain assistance. Please contact:

Public Information Dept., Pasco County Government Center 7530 Little Rd. New Port Richey, FL 34654 Phone: 727.847.8110 (voice) in New Port Richey 352.521.4274, ext 8110 (voice) in Dade City Or 711 for the hearing impaired

Contact should be initiated at least seven days before the scheduled court appearance, or immediately upon receiving this notification if the time before the scheduled appearance is less than seven days.

The court does not provide transportation and cannot accommodate such requests. Persons with disabilities needing transportation to court should contact their local public transportation providers for information regarding transportation services.

Dated in Hillsborough County, Florida, this 26th day of March, 2014

/s/ Erik Del'Etoile  
Erik Del'Etoile, Esq.  
FL Bar # 71675

Albertelli Law  
Attorney for Plaintiff  
P.O. Box 23028  
Tampa, FL 33623  
(813) 221-4743  
(813) 221-9171 facsimile  
eService: servealaw@albertellilaw.com  
JR- 11-97683  
April 4, 11, 2014 14-01945P

## FIRST INSERTION

NOTICE OF SALE IN THE CIRCUIT CIVIL COURT OF THE SIXTH JUDICIAL CIRCUIT OF FLORIDA, IN AND FOR PASCO COUNTY CIVIL DIVISION

**Case No. 51-2013-CA-001275WS Division J2**

**GROW FINANCIAL FEDERAL CREDIT UNION Plaintiff, vs.**

**UNKNOWN SUCCESSORS TRUSTEES OF THE FRANK J. DEBLASIO A/K/A FRANK J. DEBLASIO JR AND VIRGINIA M. DEBLASIO REVOCABLE TRUST, DATED AUGUST 8, 1990., UNKNOWN BENEFICIARIES OF THE ESTATE OF VIRGINIA M. DEBLASIO AND UNKNOWN TENANTS/OWNERS, Defendants.**

Notice is hereby given, pursuant to Final Judgment of Foreclosure for Plaintiff entered in this cause on March 5, 2014, in the Circuit Court of Pasco County, Florida, Paula O'Neil, Clerk of the Circuit Court, will sell the property situated in Pasco County, Florida described as:

LOT 1087 SEVEN SPRINGS HOMES UNIT FIVE- B PHASE 2 ACCORDING TO THE MAP OR PLAT THEREOF AS RECORDED IN PLAT BOOK 17 PAGES 1 THROUGH 3 OF THE PUBLIC RECORDS OF PASCO COUNTY, FLORIDA.

and commonly known as: 3410 MARTELL ST, NEW PORT RICHEY, FL 34655; including the building, appurtenances, and fixtures located therein, at public sale, to the highest and best

bidder, for cash, www.pasco.realforeclose.com, on April 22, 2014 at 11:00 AM.

Any persons claiming an interest in the surplus from the sale, if any, other than the property owner as of the date of the lis pendens must file a claim within 60 days after the sale.

If you are a person with a disability who needs any accommodation in order to participate in this proceeding, you are entitled, at no cost to you, to the provision of certain assistance. Please contact the Public Information Dept., Pasco County Government Center, 7530 Little Rd., New Port Richey, FL 34654; (727) 847-8110 (V) in New Port Richey; (352) 521-4274, ext 8110 (V) in Dade City, at least 7 days before your scheduled court appearance, or immediately upon receiving this notification if the time before the scheduled appearance is less than 7 days; if you are hearing impaired call 711. The court does not provide transportation and cannot accommodate for this service. Persons with disabilities needing transportation to court should contact their local public transportation providers for information regarding transportation services.

By: David J. Melvin  
Attorney for Plaintiff

Invoice to:  
David J. Melvin  
(813) 229-0900 x1327  
Kass Shuler, P.A.  
P.O. Box 800  
Tampa, FL 33601-0800  
ForeclosureService@kasslaw.com  
000100/1226639/  
April 4, 11, 2014 14-01964P

## FIRST INSERTION

NOTICE OF FORECLOSURE SALE IN THE CIRCUIT COURT OF THE SIXTH JUDICIAL CIRCUIT, IN AND FOR PASCO COUNTY, FLORIDA CIVIL DIVISION

**CASE NO.: 51-2012-CA-007503-XXXX-ES JPMORGAN CHASE BANK, NATIONAL ASSOCIATION SUCCESSOR BY MERGER TO CHASE HOME FINANCE, LLC Plaintiff, vs.**

**ZULMA E. DIXON, et al Defendants.**

NOTICE IS HEREBY GIVEN pursuant to a Summary Final Judgment of foreclosure dated January 28, 2014, and entered in Case No. 51-2012-CA-007503-XXXX-ES of the Circuit Court of the SIXTH Judicial Circuit in and for PASCO COUNTY, Florida, wherein JPMORGAN CHASE BANK, NATIONAL ASSOCIATION SUCCESSOR BY MERGER TO CHASE HOME FINANCE, LLC, is Plaintiff, and ZULMA E. DIXON, et al are Defendants, the clerk will sell to the highest and best bidder for cash, beginning at 11:00 AM at www.pasco.realforeclose.com, in accordance with Chapter 45, Florida Statutes, on the 29 day of April, 2014, the following described property as set forth in said Summary Final Judgment, to wit:

Lot 20, Block 2, LAKE BERNADETTE PARCELS 17 and 18A, according to the map or plat thereof recorded in Plat Book 55, pages 42 through 48, inclusive, public records of Pasco County, Florida.

Any person claiming an interest in the surplus funds from the sale, if any, other than the property owner as of the

date of the lis pendens must file a claim within 60 days after the sale.

If you are a person with a disability who needs any accommodation to participate in this proceeding, you are entitled, at no cost to you, to the provision of certain assistance. Please contact the Public Information Dept., Pasco County Government Center, 7530 Little Rd., New Port Richey, FL 34654; (727) 847-8110 (V) in New Port Richey; (352) 521-4274, ext 8110 (V) in Dade City, at least 7 days before your scheduled court appearance, or immediately upon receiving this notification if the time before the scheduled appearance is less than seven (7) days; if you are hearing or voice impaired, call 711.

The court does not provide transportation and cannot accommodate for this service. Persons with disabilities needing transportation to court should contact their local public transportation providers for information regarding transportation services.

Dated: March 28, 2014  
By: /s/ Heather J. Koch  
Phelan Hallinan, PLC  
Heather J. Koch, Esq.,  
Florida Bar No. 89107  
Emilio R. Lenzi, Esq.,  
Florida Bar No. 0668273

Phelan Hallinan, PLC  
Attorneys for Plaintiff  
2727 West Cypress Creek Road  
Ft. Lauderdale, FL 33309  
Tel: 954-462-7000  
Fax: 954-462-7001  
Service by email:  
FL.Service@PhelanHallinan.com  
PH # 18779  
April 4, 11, 2014 14-01967P

## FIRST INSERTION

NOTICE OF RESCHEDULED SALE IN THE CIRCUIT COURT OF THE SIXTH JUDICIAL CIRCUIT IN AND FOR PASCO COUNTY, FLORIDA CIVIL ACTION

**CASE NO.: 51-2009-CA-007672-CAAX-WS WACHOVIA MORTGAGE, FSB F/K/A WORLD SAVINGS BANK, FSB, Plaintiff, vs. BERTHA, DONALD et al, Defendant(s).**

NOTICE IS HEREBY GIVEN Pursuant to an Order Rescheduling Foreclosure Sale dated on or about March 7, 2014, and entered in Case No. 51-2009-CA-007672-CAAX-WS of the Circuit Court of the Sixth Judicial Circuit in and for Pasco County, Florida in which Wachovia Mortgage, FSB f/k/a World Savings Bank, FSB, is the Plaintiff and Donald M. Bertha, United States of America, Department of the Treasury, are defendants, the Pasco County Clerk of the Circuit Court will sell to the highest and best bidder for cash held online www.pasco.realforeclose.com: in Pasco County, Florida, Pasco County, Florida at 11:00AM on the 22nd day of April 2014, the following described property as set forth in said Final Judgment of Foreclosure:

LOT 16 AND THE EAST 4.5 FEET OF LOT 24, OLDFIELD, ACORDING TO THE PLAT THEREOF AS RECORDED IN PLAT BOOK 31, PAGES 67 AND 68, OF THE PUBLIC RECORDS OF PASCO COUNTY, FLORIDA. 6034 CANOPY OAKS COURT, NEW PORT RICHEY, FL 34653

Any person claiming an interest in the

surplus from the sale, if any, other than the property owner as of the date of the Lis Pendens must file a claim within 60 days after the sale.

If you are a person with a disability who needs any accommodation in order to participate in this proceeding, you are entitled, at no cost to you, to the provision of certain assistance. Please contact:

Public Information Dept., Pasco County Government Center 7530 Little Rd. New Port Richey, FL 34654 Phone: 727.847.8110 (voice) in New Port Richey 352.521.4274, ext 8110 (voice) in Dade City Or 711 for the hearing impaired

Contact should be initiated at least seven days before the scheduled court appearance, or immediately upon receiving this notification if the time before the scheduled appearance is less than seven days.

The court does not provide transportation and cannot accommodate such requests. Persons with disabilities needing transportation to court should contact their local public transportation providers for information regarding transportation services.

Dated in Hillsborough County, Florida, this 26th day of March, 2014

/s/ Erik Del'Etoile  
Erik Del'Etoile, Esq.  
FL Bar # 71675

Albertelli Law  
Attorney for Plaintiff  
P.O. Box 23028  
Tampa, FL 33623  
(813) 221-4743  
(813) 221-9171 facsimile  
eService: servealaw@albertellilaw.com  
JR- 09-23903  
April 4, 11, 2014 14-01931P

## FIRST INSERTION

NOTICE OF FORECLOSURE SALE IN THE CIRCUIT COURT OF THE SIXTH JUDICIAL CIRCUIT IN AND FOR PASCO COUNTY, FLORIDA CIVIL ACTION

**CASE NO.: 51-2012-CA-001894WS DIVISION: J3**

**JAMES B. NUTTER & COMPANY, Plaintiff, vs. JOHN L. GEORGETTE, et al, Defendant(s).**

NOTICE IS HEREBY GIVEN pursuant to a Final Judgment of Mortgage Foreclosure dated March 24, 2014 and entered in Case No. 51-2012-CA-001894WS of the Circuit Court of the SIXTH Judicial Circuit in and for PASCO County, Florida wherein JAMES B. NUTTER & COMPANY is the Plaintiff and JOHN L. GEORGETTE; JEANETTE F. GEORGETTE A/K/A JEANETTE F. GEORGETTE; ANY AND ALL UNKNOWN PARTIES CLAIMING BY, THROUGH, UNDER, AND AGAINST THE HEREIN NAMED INDIVIDUAL DEFENDANT(S) WHO ARE NOT KNOWN TO BE DEAD OR ALIVE, WHETHER SAID UNKNOWN PARTIES MAY CLAIM AN INTEREST AS SPOUSES, HEIRS, DEVEISEES, GRANTEES, OR OTHER CLAIMANTS; UNITED STATES OF AMERICA ON BEHALF OF U.S. DEPARTMENT OF HOUSING AND URBAN DEVELOPMENT; are the Defendants, The Clerk will sell to the highest and best bidder for cash at WWW.PASCO.REALFORECLOSE.COM IN ACCORDANCE WITH CHAPTER 45 FLORIDA STATUTES at 11:00AM, on 05/06/2014, the following described property as

set forth in said Final Judgment: LOT 2078, REGENCY PARK UNIT THIRTEEN, ACCORDING TO THE PLAT THEREOF AS RECORDED IN PLAT BOOK 16, PAGE 65, OF THE PUBLIC RECORDS OF PASCO COUNTY, FLORIDA

A/K/A 9011 COLLAGE LANE, PORT RICHEY, FL 34668

Any person claiming an interest in the surplus from the sale, if any, other than the property owner as of the date of the Lis Pendens must file a claim within sixty (60) days after the sale.

\*\*See Americans with Disabilities Act

If you are a person with a disability who needs any accommodation in order to participate in this proceeding, you are entitled, at no cost to you, to the provision of certain assistance. Please contact:

Public Information Dept., Pasco County Government Center 7530 Little Rd. New Port Richey, FL 34654 Phone: 727.847.8110 (voice) in New Port Richey 352.521.4274, ext 8110 (voice) in Dade City Or 711 for the hearing impaired

Contact should be initiated at least seven days before the scheduled court appearance, or immediately upon receiving this notification if the time before the scheduled appearance is less than seven days.  
By: J. Bennett Kitterman  
Florida Bar No. 98636  
Ronald R Wolfe & Associates, P.L.  
P.O. Box 25018  
Tampa, Florida 33622-5018  
(813) 251-4766  
(813) 251-1541 Fax  
F12001134  
April 4, 11, 2014 14-01941P

## FIRST INSERTION

NOTICE OF FORECLOSURE SALE IN THE CIRCUIT COURT OF THE SIXTH JUDICIAL CIRCUIT IN AND FOR PASCO COUNTY, FLORIDA

**GENERAL JURISDICTION DIVISION Case No.**

**51-2013-CA-000016-CAAX-ES Owen Loan Servicing, LLC, Plaintiff, vs.**

**Richard Ellis; Kerry Ellis; Lake Padgett Estates East Property Owners Association, Inc.; and Unknown Tenants/Owners, Defendants.**

NOTICE IS HEREBY GIVEN pursuant to a Final Judgment of Foreclosure dated February 25, 2014, entered in Case No. 51-2013-CA-000016-CAAX-ES of the Circuit Court of the Sixth Judicial Circuit, in and for Pasco County, Florida, wherein Owen Loan Servicing, LLC is the Plaintiff and Richard Ellis; Kerry Ellis; Lake Padgett Estates East Property Owners Association, Inc.; and Unknown Tenants/Owners are the Defendants, that the Clerk of Courts will sell to the highest and best bidder for cash by electronic sale at www.pasco.realforeclose.com, beginning at 11:00 AM on the 28th day of April, 2014, the following described property as set forth in said Final Judgment, to wit:

LOT 402, LAKE PADGETT ESTATES EAST, PASCO COUNTY, FLORIDA, BEGIN 1070.42 FEET SOUTH AND 1976.68 FEET EAST OF THE SOUTHWEST CORNER OF THE NORTHWEST ¼ OF SECTION 17, TOWNSHIP 26 SOUTH, RANGE 19 EAST,

RUN THENCE SOUTH 61°49' 58" W, 110.12 FEET, THENCE SOUTH 49°36' 28" WEST, 14.62 FEET, THENCE SOUTH 24°07'56" EAST, 132.84 FEET, THENCE NORTH 63°04'14" EAST, 53.05 FEET, THENCE NORTH 02°23'30" EAST, 158.81 FEET TO THE POINT OF BEGINNING.

If you are a person with a disability who needs any accommodation in order to participate in this proceeding, you are entitled, at no cost to you, to the provision of certain assistance. Please contact the Public Information Dept., Pasco County Government Center, 7530 Little Rd., New Port Richey, FL 34654; (727) 847-8110 (V) in New Port Richey; (352) 521-4274, ext 8110 (V) in Dade City, at least 7 days before your scheduled court appearance, or immediately upon receiving this notification if the time before the scheduled appearance is less than 7 days; if you are hearing impaired call 711. The court does not provide transportation and cannot accommodate for this service. Persons with disabilities needing transportation to court should contact their local public transportation providers for information regarding transportation services.

Dated this 28 day of March, 2014.  
By Kathleen McCarthy, Esq.  
Florida Bar No. 72161

BROCK & SCOTT, PLLC  
Attorney for Plaintiff  
1501 N.W. 49th Street, Suite 200  
Ft. Lauderdale, FL 33309  
Phone: (954) 618-6955, ext. 6177  
Fax: (954) 618-6954  
FLCourtDocs@brockandscott.com  
14-F00543  
April 4, 11, 2014 14-01968P



**FIRST INSERTION**

**NOTICE OF SALE**  
IN THE CIRCUIT COURT OF THE SIXTH JUDICIAL CIRCUIT IN AND FOR PASCO COUNTY, FLORIDA  
**CASE NO. 51-2012-CA-002053WS**  
**U.S. BANK NATIONAL ASSOCIATION**  
**Plaintiff, v.**  
**SANDRA BARRETT; MATT BARRETT; UNKNOWN TENANT 1; UNKNOWN TENANT 2; AND ALL UNKNOWN PARTIES CLAIMING BY, THROUGH, UNDER OR AGAINST THE ABOVE NAMED DEFENDANT(S), WHO (IS/ARE) NOT KNOWN TO BE DEAD OR ALIVE, WHETHER SAID UNKNOWN PARTIES CLAIM AS HEIRS, DEVISEES, GRANTEES, ASSIGNEES, LIENORS, CREDITORS, TRUSTEES, SPOUSES, OR OTHER CLAIMANTS; FLORIDA HOUSING FINANCE CORPORATION**  
**Defendants.**  
Notice is hereby given that, pursuant to the Summary Final Judgment of Foreclosure entered on February 27, 2014, in this cause, in the Circuit Court of Pasco County, Florida, the clerk shall sell the property situated in Pasco County, Florida, described as:  
LOT 51, RIDGE CREST GARDENS, ACCORDING TO THE PLAT THEREOF AS RECORDED IN PLAT BOOK 12, PAGES 4-7, PUBLIC RECORDS OF PASCO COUNTY, FLORIDA, a/k/a 8726 CONGRESS ST, PORT RICHEY, FL 34668-5443 at public sale, to the highest and best bidder, for cash, online at www.pasco.realforeclose.com, on April 15, 2014 beginning at 11:00 AM.  
If you are a person claiming a right to funds remaining after the sale, you must file a claim with the clerk no later than 60 days after the sale. If you fail to file a claim you will not be entitled to any remaining funds.  
ANY PERSONS WITH A DISABILITY REQUIRING REASONABLE ACCOMMODATIONS SHOULD CALL NEW PORT RICHEY (813) 847-8110; DADE CITY (352) 521-4274 EXT 8110; TDD 1-800-955-8771 VIA FLORIDA RELAY SERVICE, NO LATER THAN SEVEN (7) DAYS PRIOR TO ANY PROCEEDING.  
Dated at St. Petersburg, Florida, this 28 day of March, 2014.  
By: Nancy W. Hunt  
FBN 0651923  
Douglas C. Zahm, P.A.  
Designated Email Address:  
efiling@dczahm.com  
12425 28th Street North, Suite 200  
St. Petersburg, FL 33716  
Telephone No. (727) 536-4911  
Attorney for the Plaintiff  
665100137  
April 4, 11, 2014 14-01961P

**FIRST INSERTION**

**NOTICE OF SALE**  
IN THE CIRCUIT COURT OF THE SIXTH JUDICIAL CIRCUIT OF THE STATE OF FLORIDA, IN AND FOR PASCO COUNTY  
CIVIL DIVISION  
**Case No. 51-2011-CA-003326-CAAX-WS**  
**SUNTRUST MORTGAGE, INC., Plaintiff, vs.**  
**KAREN MARIE FITCH; ORCHID LAKE VILLAGE CIVIC ASSOCIATION, INC.; UNKNOWN SPOUSE OF KAREN MARIE FITCH; UNKNOWN TENANT IN POSSESSION OF THE SUBJECT PROPERTY; Defendant(s)**  
Notice is hereby given that, pursuant to a Final Summary Judgment of Foreclosure entered on 03/05/2014 in the above-styled cause, in the Circuit Court of Pasco County, Florida, the office of Paula S. O'Neil clerk of the circuit court will sell the property situated in Pasco County, Florida, described as:  
LOT 233, ORCHID LAKE VILLAGE, UNIT TWO, ACCORDING TO THE PLAT THEREOF, AS RECORDED IN PLAT BOOK 18, AT PAGES 106 THROUGH 109, OF THE PUBLIC RECORDS OF PASCO COUNTY, FLORIDA.  
at public sale, to the highest and best bidder, for cash, www.pasco.realforeclose.com at 11:00 o'clock, A.M, on April 21, 2014  
Any person claiming an interest in the surplus from the sale, if any, other than the property owner as of the date of the lis pendens, must file a claim within 60 days after the sale.  
If you are a person with a disability who needs any accommodation in order to participate in this proceeding, you are entitled, at no cost to you, to the provision of certain assistance. Please contact the Public Information Dept., Pasco County Government Center, 7530 Little Rd., New Port Richey, FL 34654; (727) 847-8110 (V) for proceedings in New Port Richey; (352) 521-4274, ext. 8110 (V) for proceedings in Dade City, at least 7 days before your scheduled court appearance, or immediately upon receiving this notification if the time before the scheduled appearance is less than 7 days; if you are hearing impaired call 711.  
Date: 03/31/2014  
**ATTORNEY FOR PLAINTIFF**  
By /s/ Josh D. Donnelly  
Josh D. Donnelly  
Florida Bar #64788  
**THIS INSTRUMENT PREPARED BY:**  
Law Offices of Daniel C. Consuegra  
9204 King Palm Drive  
Tampa, FL 33619-1328  
Phone: 813-915-8660  
Attorneys for Plaintiff  
141104  
April 4, 11, 2014 14-02000P

**FIRST INSERTION**

**NOTICE OF SALE**  
IN THE CIRCUIT COURT OF THE SIXTH JUDICIAL CIRCUIT IN AND FOR PASCO COUNTY, FLORIDA  
CIVIL DIVISION  
**Case #: 51-2010-CA-007411-ES**  
**DIVISION: J4**  
**Regions Bank d/b/a Regions Mortgage**  
**Plaintiff, vs.-**  
**Mark James Winter and Dorothea M. Phillips, His Wife; Seven Oaks Property Owners' Association, Inc.; Defendant(s).**  
NOTICE IS HEREBY GIVEN pursuant to a Final Judgment, entered in Civil Case No. 51-2010-CA-007411-ES of the Circuit Court of the 6th Judicial Circuit in and for Pasco County, Florida, wherein Regions Bank d/b/a Regions Mortgage, Plaintiff and Mark James Winter and Dorothea M. Phillips, His Wife are defendant(s), I, Clerk of Court, Paula S. O'Neil, will sell to the highest and best bidder for cash in an online sale accessed through the Clerk's website at www.pasco.realforeclose.com, at 11:00 a.m. on May 5, 2014, the following described property as set forth in said Final Judgment, to-wit:  
LOT 35, BLOCK 28, SEVEN OAKS PARCEL S-8B1, ACCORDING TO THE MAP OR PLAT THEREOF, AS RECORDED IN PLAT BOOK 47, PAGES 94 THROUGH 106, OF THE PUBLIC RECORDS OF PASCO COUNTY, FLORIDA.  
ANY PERSON CLAIMING AN INTEREST IN THE SURPLUS FROM THE SALE, IF ANY, OTHER THAN THE PROPERTY OWNER AS OF THE DATE OF THE LIS PENDENS MUST FILE A CLAIM WITHIN 60 DAYS AFTER THE SALE.  
If you are a person with a disability who needs any accommodation in order to participate in this proceeding, you are entitled, at no cost to you, to the provision of certain assistance. Please contact the ADA Coordinator; 14250 49th Street North, Clearwater, Florida 33762 (727) 453-7163 at least 7 days before your scheduled court appearance, or immediately upon receiving this notification of the time before the scheduled appearance is less than 7 days. If you are hearing or voice impaired, call 711.  
Submitted By:  
**ATTORNEY FOR PLAINTIFF:**  
SHAPIRO, FISHMAN & GACHÉ, LLP  
2424 North Federal Highway,  
Suite 360  
Boca Raton, Florida 33431  
(561) 998-6700  
(561) 998-6707  
10-186992 FCO1 UPN  
April 4, 11, 2014 14-01954P

**FIRST INSERTION**

**NOTICE OF SALE**  
IN THE CIRCUIT COURT OF THE SIXTH JUDICIAL CIRCUIT IN AND FOR PASCO COUNTY, FLORIDA  
CIVIL DIVISION  
**Case #: 51-2010-CA-007843-WS (J3)**  
**DIVISION: J3**  
**BAC Home Loans Servicing, L.P. f/k/a Countrywide Home Loans Servicing, L.P.**  
**Plaintiff, vs.-**  
**Larry K. Ritter; Defendant(s).**  
NOTICE IS HEREBY GIVEN pursuant to a Final Judgment, entered in Civil Case No. 51-2010-CA-007843-WS (J3) of the Circuit Court of the 6th Judicial Circuit in and for Pasco County, Florida, wherein BAC Home Loans Servicing, L.P. f/k/a Countrywide Home Loans Servicing, L.P., Plaintiff and Larry K. Ritter are defendant(s), I, Clerk of Court, Paula S. O'Neil, will sell to the highest and best bidder for cash in an online sale accessed through the Clerk's website at www.pasco.realforeclose.com, at 11:00 a.m. on April 25, 2014, the following described property as set forth in said Final Judgment, to-wit:  
LOT 2415, REGENCY PARK UNIT SEVENTEEN, ACCORDING TO THE PLAT THEREOF AS RECORDED IN PLAT BOOK 17, PAGES 69 AND 70, OF THE PUBLIC RECORDS OF PASCO COUNTY, FLORIDA.  
ANY PERSON CLAIMING AN INTEREST IN THE SURPLUS FROM THE SALE, IF ANY, OTHER THAN THE PROPERTY OWNER AS OF THE DATE OF THE LIS PENDENS MUST FILE A CLAIM WITHIN 60 DAYS AFTER THE SALE.  
If you are a person with a disability who needs any accommodation in order to participate in this proceeding, you are entitled, at no cost to you, to the provision of certain assistance. Please contact the ADA Coordinator; 14250 49th Street North, Clearwater, Florida 33762 (727) 453-7163 at least 7 days before your scheduled court appearance, or immediately upon receiving this notification of the time before the scheduled appearance is less than 7 days. If you are hearing or voice impaired, call 711.  
Submitted By:  
**ATTORNEY FOR PLAINTIFF:**  
SHAPIRO, FISHMAN & GACHÉ, LLP  
2424 North Federal Highway,  
Suite 360  
Boca Raton, Florida 33431  
(561) 998-6700  
(561) 998-6707  
10-192585 FCO1 CWF  
April 4, 11, 2014 14-01955P

**FIRST INSERTION**

**NOTICE OF FORECLOSURE SALE**  
IN THE CIRCUIT COURT OF THE 6TH JUDICIAL CIRCUIT, IN AND FOR PASCO COUNTY, FLORIDA.  
**CASE No. 51-2012-CA-007403-ES**  
**BANK OF AMERICA, N.A., Plaintiff, vs.**  
**BROWN, JEROME A., et al., Defendants.**  
NOTICE IS HEREBY GIVEN pursuant to an Order or Final Judgment entered in Case No. 51-2012-CA-007403-ES of the Circuit Court of the 6TH Judicial Circuit in and for PASCO County, Florida, wherein, BANK OF AMERICA, N.A., Plaintiff, and, BROWN, JEROME A., et al., are Defendants, the Clerk of Court will sell to the highest bidder for cash at, WWW.PASCO.REALFORECLOSE.COM, at the hour of 11:00 A.M., on the 17th day of April, 2014, the following described property:  
LOT 27, COUNTRY WALK INCREMENT B PHASE 1, ACCORDING TO THE PLAT THEREOF RECORDED IN PLAT BOOK 55, PAGES 12 TO 17, INCLUSIVE OF THE PUBLIC RECORDS OF PASCO COUNTY, FLORIDA  
Any person claiming an interest in the surplus from the sale, if any, other than the property owner as of the date of the lis pendens, must file a claim within 60 days after the sale.  
**IMPORTANT**  
If you are a person with a disability who needs any accommodation in order to participate in this proceeding, you are entitled, at no cost to you, to the provision of certain assistance. Please contact the Clerk of the Court's disability coordinator at PUBLIC INFORMATION DEPARTMENT, PASCO COUNTY GOVERNMENT CENTER, 7530 LITTLE ROAD, NEW PORT RICHEY, FL 34654-7278-847-8110. at least 7 days before your scheduled court appearance, or immediately upon receiving this notification if the time before the scheduled appearance is less than 7 days; if you are hearing or voice impaired, call 711.  
DATED this 27 day of March, 2014.  
By: Karissa Chin-Duncan, Esq.  
Florida Bar No.: 98472  
**GREENSPOON MARDER, P.A.**  
**TRADE CENTRE SOUTH,**  
**SUITE 700**  
**100 WEST CYPRESS CREEK ROAD**  
**FORT LAUDERDALE, FL 33309**  
Telephone: (954) 343 6273  
Hearing Line: (888) 491-1120  
Facsimile: (954) 343 6982  
Email:  
karissa.chin-duncan@gmlaw.com  
Email 2: gmforeclosure@gmlaw.com  
(262) 217.3382/LLyons  
April 4, 11, 2014 14-01943P

**FIRST INSERTION**

**NOTICE OF SALE**  
IN THE CIRCUIT COURT OF THE SIXTH JUDICIAL CIRCUIT, IN AND FOR PASCO COUNTY, FLORIDA  
**CASE NO.: 51-2010-CA-003626-WS**  
**BANK OF AMERICA, N.A., Plaintiff, vs.**  
**SHAWN HARMON, et al., Defendants,**  
NOTICE IS GIVEN that, in accordance with the Plaintiff's Final Judgment of Foreclosure entered on March 7, 2014 in the above-styled cause, the property will be sold to the highest and best bidder for cash on April 23, 2014 at 11:00 A.M. at www.pasco.realforeclose.com, the following described property:  
ALL THAT CERTAIN LAND SITUATED IN PASCO COUNTY, STATE OF FLORIDA, VIZ: LOT 1592, EMBASSY HILLS, UNIT NINE, ACCORDING TO THE MAP OR PLAT THEREOF, AS RECORDED IN PLAT BOOK 14, PAGE(S) 98 AND 99, INCLUSIVE OF THE PUBLIC RECORDS OF PASCO COUNTY, FLORIDA.  
Property Address: 7321 Lincoln Park Lane, Port Richey, FL 34668.  
ANY PERSON CLAIMING AN INTEREST IN THE SURPLUS FROM THE SALE, IF ANY, OTHER THAN THE PROPERTY OWNER AS OF THE DATE OF THE LIS PENDENS MUST FILE A CLAIM WITHIN 60 DAYS AFTER THE SALE.  
**AMERICANS WITH DISABILITIES ACT**  
If you are a person with a disability who needs any accommodation in order to participate in this proceeding, you are entitled, at no cost to you to the provision of certain assistance. Within two (2) working days of your receipt of this describing notice/order please contact the Public Information Dept., Pasco County Government Center, 7530 Little Rd., New Port Richey, FL 34654; (727) 847-8110 (V) in New Port Richey; (352) 521-4274, ext. 8110 (V) in Dade City; via 1-800-955-8771 if you are hearing impaired. The court does not provide transportation and cannot accommodate for this service. Persons with disabilities needing transportation to court should contact their local public transportation providers for information regarding disabled transportation services.  
Brenda Jean, Esquire  
Florida Bar No.: 89812  
Quinteiros, Prieto, Wood & Boyer, P.A.  
225 S. Orange Ave., Ste. 900  
Orlando, FL 32801-3454  
(407) 872-6011  
(407) 872-6012 Facsimile  
E-mail: servicecopies@qpwbaw.com  
E-mail: bjean@qpwbaw.com  
Matter #60318  
April 4, 11, 2014 14-01988P

**FIRST INSERTION**

**NOTICE OF SALE**  
IN THE CIRCUIT CIVIL COURT OF THE SIXTH JUDICIAL CIRCUIT OF FLORIDA, IN AND FOR PASCO COUNTY  
CIVIL DIVISION  
**Case No. 51-2012-CA-007669WS**  
**Division J2**  
**BRANCH BANKING AND TRUST COMPANY**  
**Plaintiff, vs.**  
**UNKNOWN TRUSTEE OF THE ANTHONY FERENTINOS AND VASSILIKI FERENTINOS REVOCABLE LIVING TRUST, DATED DECEMBER 9, 1996, UNKNOWN BENEFICIARIES OF THE ANTHONY FERENTINOS AND VASSILIKI FERENTINOS REVOCABLE LIVING TRUST, DATED DECEMBER 9, 1996, BEACON WOODS EAST RECREATION ASSOCIATION, INC., BEACON WOODS EAST MASTER ASSOCIATION, INC., THE ESTATES OF BEACON WOODS GOLF & COUNTRY CLUB PROPERTY OWNERS ASSOCIATION, INC., AND UNKNOWN TENANTS/OWNERS, Defendants.**  
Notice is hereby given, pursuant to Final Judgment of Foreclosure for Plaintiff entered in this cause on March 5, 2014, in the Circuit Court of Pasco County, Florida, Paula O'Neil, Clerk of the Circuit Court, will sell the property situated in Pasco County, Florida described as:  
LOT 21, THE ESTATES OF BEACON WOODS GOLF AND COUNTRY CLUB PHASE 4, ACCORDING TO THE PLAT THEREOF ON FILE IN THE OFFICE OF THE CLERK OF THE CIRCUIT COURT IN AND FOR PASCO COUNTY, FLORIDA RECORDED IN PLAT BOOK 29, PAGES 113 AND 114; SAID

LANDS SITUATE LYING AND BEING IN PASCO COUNTY, FLORIDA.  
and commonly known as: 14319 TEASDALE AVE, HUDSON, FL 34667; including the building, appurtenances, and fixtures located therein, at public sale, to the highest and best bidder, for cash, www.pasco.realforeclose.com, on April 22, 2014 at 11:00 AM.  
Any persons claiming an interest in the surplus from the sale, if any, other than the property owner as of the date of the lis pendens must file a claim within 60 days after the sale.  
If you are a person with a disability who needs any accommodation in order to participate in this proceeding, you are entitled, at no cost to you, to the provision of certain assistance. Please contact the Public Information Dept., Pasco County Government Center, 7530 Little Rd., New Port Richey, FL 34654; (727) 847-8110 (V) in New Port Richey; (352) 521-4274, ext 8110 (V) in Dade City, at least 7 days before your scheduled court appearance, or immediately upon receiving this notification if the time before the scheduled appearance is less than 7 days; if you are hearing impaired call 711. The court does not provide transportation and cannot accommodate for this service. Persons with disabilities needing transportation to court should contact their local public transportation providers for information regarding transportation services.  
By: Michael L. Tebbi  
Attorney for Plaintiff  
Invoice to:  
Michael L. Tebbi  
(813) 229-0900 xl346  
Kass Shuler, P.A.  
P.O. Box 800  
Tampa, FL 33601-0800  
ForeclosureService@kasslaw.com  
266400/1216406/am11  
April 4, 11, 2014 14-01933P

**FIRST INSERTION**

**NOTICE OF FORECLOSURE SALE**  
IN THE CIRCUIT COURT OF THE SIXTH JUDICIAL CIRCUIT, IN AND FOR PASCO COUNTY, FLORIDA  
CIVIL DIVISION  
**CASE NO.: 51-2008-CA-001530-ES**  
**US BANK NATIONAL ASSOCIATION AS TRSUTEE, SUCCESSOR IN INTEREST TO BANK OF AMERICA, NA AS TRUSTEE SUCCESSOR BY MERGER TO LASALLE BANK NA AS TRUSTEE FOR WASHINGTON MUTUAL ASSET-BACKED CERTIFICATES WMABS SERIES 2007-HE1 TRUST**  
**Plaintiff, vs.**  
**NICHOLAS RICKETTS, et al Defendants.**  
NOTICE IS HEREBY GIVEN pursuant to a Summary Final Judgment of foreclosure dated March 05, 2014, and entered in Case No. 51-2008-CA-001530-ES of the Circuit Court of the SIXTH Judicial Circuit in and for PASCO COUNTY, Florida, wherein US BANK NATIONAL ASSOCIATION AS TRSUTEE, SUCCESSOR IN INTEREST TO BANK OF AMERICA, NA AS TRUSTEE SUCCESSOR BY MERGER TO LASALLE BANK NA AS TRUSTEE FOR WASHINGTON MUTUAL ASSET-BACKED CERTIFICATES WMABS SERIES 2007-HE1 TRUST, is Plaintiff, and NICHOLAS RICKETTS, et al are Defendants, the clerk will sell to the highest and best bidder for cash, beginning at 11:00 AM at www.pasco.realforeclose.com, in accordance with Chapter 45, Florida Statutes, on the 23 day of April, 2014, the following described property as set forth in said Summary Final Judgment, to wit:  
Lot 16, Block B, Chapel Pines Phase 1A, according to the map or plat thereof, as recorded in

Plat Book 42, Page 19 through 25, Public Records of Pasco County, Florida  
Any person claiming an interest in the surplus funds from the sale, if any, other than the property owner as of the date of the lis pendens must file a claim within 60 days after the sale.  
If you are a person with a disability who needs any accommodation in order to participate in this proceeding, you are entitled, at no cost to you, to the provision of certain assistance. Please contact the Public Information Dept., Pasco County Government Center, 7530 Little Rd., New Port Richey, FL 34654; (727) 847-8110 (V) in New Port Richey; (352) 521-4274, ext 8110 (V) in Dade City, at least 7 days before your scheduled court appearance, or immediately upon receiving this notification if the time before the scheduled appearance is less than seven (7) days; if you are hearing or voice impaired, call 711.  
The court does not provide transportation and cannot accommodate for this service. Persons with disabilities needing transportation to court should contact their local public transportation providers for information regarding transportation services.  
Dated: March 26, 2014  
By: /s/ Heather J. Koch  
Phelan Hallinan, PLC  
Heather J. Koch, Esq.,  
Florida Bar No. 89107  
Emilio R. Lenzi, Esq.,  
Florida Bar No. 0668273  
Phelan Hallinan, PLC  
Attorneys for Plaintiff  
2727 West Cypress Creek Road  
Ft. Lauderdale, FL 33309  
Tel: 954-462-7000  
Fax: 954-462-7001  
Service by email:  
FL.Service@PhelanHallinan.com  
PH # 24937  
April 4, 11, 2014 14-01938P

**FIRST INSERTION**

**NOTICE OF FORECLOSURE SALE**  
IN THE CIRCUIT COURT OF THE SIXTH JUDICIAL CIRCUIT, IN AND FOR PASCO COUNTY, FLORIDA  
CIVIL DIVISION  
**CASE NO.: 51-2012-CA-007273-XXXX-ES**  
**JPMORGAN CHASE BANK, NATIONAL ASSOCIATION, SUCCESSOR IN INTEREST BY PURCHASE FROM THE FEDERAL DEPOSIT INSURANCE CORPORATION AS RECEIVER OF WASHINGTON MUTUAL BANK F/K/A WASHINGTON MUTUAL BANK, FA**  
**Plaintiff, vs.**  
**JEFFREY BLASKVITCH, et al Defendants.**  
NOTICE IS HEREBY GIVEN pursuant to a Summary Final Judgment of foreclosure dated January 22, 2014, and entered in Case No. 51-2012-CA-007273-XXXX-ES of the Circuit Court of the SIXTH Judicial Circuit in and for PASCO COUNTY, Florida, wherein JPMORGAN CHASE BANK, NATIONAL ASSOCIATION, SUCCESSOR IN INTEREST BY PURCHASE FROM THE FEDERAL DEPOSIT INSURANCE CORPORATION AS RECEIVER OF WASHINGTON MUTUAL BANK F/K/A WASHINGTON MUTUAL BANK, FA, is Plaintiff, and JEFFREY BLASKVITCH, et al are Defendants, the clerk will sell to the highest and best bidder for cash, beginning at 11:00 AM at www.pasco.realforeclose.com, in accordance with Chapter 45, Florida Statutes, on the 22 day of April, 2014, the following described property as set forth in said Summary Final Judgment, to wit:  
Lot 21, Block F, NORTHWOOD UNIT 9, according to the plat thereof as recorded in Plat Book 44, Pages 50 through 53, inclu-

sive, of the Public Records of Pasco County, Florida.  
Any person claiming an interest in the surplus funds from the sale, if any, other than the property owner as of the date of the lis pendens must file a claim within 60 days after the sale.  
If you are a person with a disability who needs any accommodation in order to participate in this proceeding, you are entitled, at no cost to you, to the provision of certain assistance. Please contact the Public Information Dept., Pasco County Government Center, 7530 Little Rd., New Port Richey, FL 34654; (727) 847-8110 (V) in New Port Richey; (352) 521-4274, ext 8110 (V) in Dade City, at least 7 days before your scheduled court appearance, or immediately upon receiving this notification if the time before the scheduled appearance is less than seven (7) days; if you are hearing or voice impaired, call 711.  
The court does not provide transportation and cannot accommodate for this service. Persons with disabilities needing transportation to court should contact their local public transportation providers for information regarding transportation services.  
Dated: March 26, 2014  
By: /s/ Heather J. Koch  
Phelan Hallinan, PLC  
Heather J. Koch, Esq.,  
Florida Bar No. 89107  
Emilio R. Lenzi, Esq.,  
Florida Bar No. 0668273  
Phelan Hallinan, PLC  
Attorneys for Plaintiff  
2727 West Cypress Creek Road  
Ft. Lauderdale, FL 33309  
Tel: 954-462-7000  
Fax: 954-462-7001  
Service by email:  
FL.Service@PhelanHallinan.com  
PH # 32769  
April 4, 11, 2014 14-01939P

**HOW TO PUBLISH YOUR LEGAL NOTICE IN THE BUSINESS OBSERVER**

**FOR MORE INFORMATION, CALL:**  
**(813) 221-9505 Hillsborough, Pasco**  
**(727) 447-7784 Pinellas**  
**(941) 906-9386 Manatee, Sarasota, Lee**  
**(239) 263-0122 Collier**  
**(407) 654-5500 Orange**  
**(941) 249-4900 Charlotte**  
 Or e-mail: [legal@businessobserverfl.com](mailto:legal@businessobserverfl.com)

FIRST INSERTION

NOTICE OF SALE IN THE COUNTY COURT OF THE 6th JUDICIAL CIRCUIT IN AND FOR PASCO COUNTY, FLORIDA CASE NO:

51-2013-CC-004109-CCAX-ES SECTION: D EILAND PARK TOWNHOMES ASSOCIATION, INC., a not-for-profit Florida corporation, Plaintiff, vs. WENDY CAPUTO; UNKNOWN SPOUSE OF WENDY CAPUTO; AND UNKNOWN TENANT(S), Defendants.

NOTICE IS HEREBY GIVEN that, pursuant to the Final Judgment entered in this cause, in the County Court of Pasco County, Florida, I will sell all the property situated in Pasco County, Florida described as:

Lot 64 of EILAND PARK TOWNHOMES, according to the Plat thereof as recorded in Plat Book 60, Page 102, of the Public Records of Pasco County, Florida, and any subsequent amendments to the aforesaid.

at public sale, to the highest and best bidder, for cash, via the Internet at www.pasco.realforeclose.com at 11:00 A.M. on April 24, 2014.

If you are a person with a disability who needs any accommodation in order to participate in this proceeding, you are entitled, at no cost to you, to the provision of certain assistance. Please contact the Public Information Dept., Pasco County Government Center, 7530 Little Rd., New Port Richey, FL 34654; (727) 847-8110 (V) in New Port Richey; (352) 521-4274, ext 8110 (V) in Dade City, at least 7 days before your scheduled court appearance, or immediately upon receiving this notification if the time before the scheduled appearance is less than 7 days; if you are hearing impaired call 711. The court does not provide transportation and cannot accommodate for this service.

By BRANDON K. MULLIS, ESQ. Attorney for Plaintiff Email: Service@MankinLawGroup.com FBN: 0023217

MANKIN LAW GROUP 2535 Landmark Drive, Suite 212 Clearwater, FL 33761 (727) 725-0559 April 4, 11, 2014 14-01934P

FIRST INSERTION

NOTICE OF SALE IN THE COUNTY COURT OF THE 6TH JUDICIAL CIRCUIT IN AND FOR PASCO COUNTY, FLORIDA CASE:

51-2013-CC-001764-CCAX-ES SECTION: T BAY AT CYPRESS CREEK HOMEOWNERS ASSOCIATION, INC., a not-for-profit Florida Corporation, Plaintiff, vs. JASON P. LEWIS; UNKNOWN SPOUSE OF JASON P. LEWIS; AND UNKNOWN TENANT(S), Defendants.

NOTICE IS HEREBY GIVEN that, pursuant to the Final Judgment entered in this cause, in the County Court of Pasco County, Florida, I will sell all the property situated in Pasco County, Florida described as:

Lot 5, Block 1, BAY AT CYPRESS CREEK, according to the Plat thereof as recorded in Plat Book 49, Pages 132-139, of the Public Records of Pasco County, Florida, and any subsequent amendments to the aforesaid.

at public sale, to the highest and best bidder, for cash, via the Internet at www.pasco.realforeclose.com at 11:00 A.M. on April 24, 2014.

If you are a person with a disability who needs any accommodation in order to participate in this proceeding, you are entitled, at no cost to you, to the provision of certain assistance. Please contact the Public Information Dept., Pasco County Government Center, 7530 Little Rd., New Port Richey, FL 34654; (727) 847-8110 (V) in New Port Richey; (352) 521-4274, ext 8110 (V) in Dade City, at least 7 days before your scheduled court appearance, or immediately upon receiving this notification if the time before the scheduled appearance is less than 7 days; if you are hearing impaired call 711. The court does not provide transportation and cannot accommodate for this service.

By BRANDON K. MULLIS, ESQ. Attorney for Plaintiff Email: Service@MankinLawGroup.com FBN: 0023217

MANKIN LAW GROUP 2535 Landmark Drive, Suite 212 Clearwater, FL 33761 (727) 725-0559 April 4, 11, 2014 14-01935P

FIRST INSERTION

NOTICE OF SALE IN THE COUNTY COURT OF THE 6TH JUDICIAL CIRCUIT IN AND FOR PASCO COUNTY, FLORIDA CASE:

51-2013-CC-001671-ES DIV T NORTHWOOD OF PASCO HOMEOWNERS ASSOCIATION, INC., a not-for-profit Florida Corporation, Plaintiff, vs. GLORIA Y. WHITE; ET AL Defendants

NOTICE IS HEREBY GIVEN that, pursuant to the Final Judgment entered in this cause, in the County Court of Pasco County, Florida, I will sell all the property situated in Pasco County, Florida described as:

Lot 41, Block H, NORTHWOOD UNIT 5, according to the Plat thereof as recorded in Plat Book 38, Pages 145-147, of the Public Records of Pasco County, Florida, and any subsequent amendments to the aforesaid.

at public sale, to the highest and best bidder, for cash, via the Internet at www.pasco.realforeclose.com at 11:00 A.M. on April 24th, 2014.

If you are a person with a disability who needs any accommodation in order to participate in this proceeding, you are entitled, at no cost to you, to the provision of certain assistance. Please contact the Public Information Dept., Pasco County Government Center, 7530 Little Rd., New Port Richey, FL 34654; (727) 847-8110 (V) in New Port Richey; (352) 521-4274, ext 8110 (V) in Dade City, at least 7 days before your scheduled court appearance, or immediately upon receiving this notification if the time before the scheduled appearance is less than 7 days; if you are hearing impaired call 711. The court does not provide transportation and cannot accommodate for this service.

By BRANDON K. MULLIS, ESQ. Attorney for Plaintiff Email: Service@MankinLawGroup.com FBN: 23217

MANKIN LAW GROUP 2535 Landmark Drive, Suite 212 Clearwater, FL 33761 (727) 725-0559 April 4, 11, 2014 14-01970P

FIRST INSERTION

NOTICE OF SALE IN THE COUNTY COURT OF THE 6TH JUDICIAL CIRCUIT IN AND FOR PASCO COUNTY, FLORIDA CASE NO: 51-2013-CC-003739-ES

VALENCIA GARDENS HOMEOWNERS ASSOCIATION, INC., a not-for-profit Florida corporation, Plaintiff, vs. PHILIP J. AHUMADA; RACHEL M. BATES; AND UNKNOWN TENANT(S), Defendants

NOTICE IS HEREBY GIVEN that, pursuant to the Final Judgment entered in this cause, in the County Court of Pasco County, Florida, I will sell all the property situated in Pasco County, Florida described as:

Lot 181, VALENCIA GARDENS PHASE ONE, according to the Plat thereof as recorded in Plat Book 36, Pages 116 through 123, of the Public Records of Pasco County, Florida, and any subsequent amendments to the aforesaid.

at public sale, to the highest and best bidder, for cash, via the Internet at www.pasco.realforeclose.com at 11:00 A.M. on April 24th, 2014.

If you are a person with a disability who needs any accommodation in order to participate in this proceeding, you are entitled, at no cost to you, to the provision of certain assistance. Please contact the Public Information Dept., Pasco County Government Center, 7530 Little Rd., New Port Richey, FL 34654; (727) 847-8110 (V) in New Port Richey; (352) 521-4274, ext 8110 (V) in Dade City, at least 7 days before your scheduled court appearance, or immediately upon receiving this notification if the time before the scheduled appearance is less than 7 days; if you are hearing impaired call 711. The court does not provide transportation and cannot accommodate for this service.

By BRANDON K. MULLIS, ESQ. Attorney for Plaintiff Email: Service@MankinLawGroup.com FBN: 23217

MANKIN LAW GROUP 2535 Landmark Drive, Suite 212 Clearwater, FL 33761 (727) 725-0559 April 4, 11, 2014 14-01971P

FIRST INSERTION

NOTICE OF SALE IN THE COUNTY COURT OF THE 6TH JUDICIAL CIRCUIT IN AND FOR PASCO COUNTY, FLORIDA CASE:

51-2013-CC-001998-ES SECTION: T MEADOW POINTE III HOMEOWNER'S ASSOCIATION, INC., a not-for-profit Florida Corporation, Plaintiff, vs. BRITINI M. KEATON; et al Defendants

NOTICE IS HEREBY GIVEN that, pursuant to the Final Judgment entered in this cause, in the County Court of Pasco County, Florida, I will sell all the property situated in Pasco County, Florida described as:

Lot 3, Block 8, MEADOW POINTE III, PARCEL CC, according to the Plat thereof as recorded in Plat Book 60, Page 12, of the Public Records of Pasco County, Florida, and any subsequent amendments to the aforesaid.

at public sale, to the highest and best bidder, for cash, via the Internet at www.pasco.realforeclose.com at 11:00 A.M. on April 28th, 2014.

If you are a person with a disability who needs any accommodation in order to participate in this proceeding, you are entitled, at no cost to you, to the provision of certain assistance. Please contact the Public Information Dept., Pasco County Government Center, 7530 Little Rd., New Port Richey, FL 34654; (727) 847-8110 (V) in New Port Richey; (352) 521-4274, ext 8110 (V) in Dade City, at least 7 days before your scheduled court appearance, or immediately upon receiving this notification if the time before the scheduled appearance is less than 7 days; if you are hearing impaired call 711. The court does not provide transportation and cannot accommodate for this service.

By BRANDON K. MULLIS, ESQ. Attorney for Plaintiff Email: Service@MankinLawGroup.com FBN: 23217

MANKIN LAW GROUP 2535 Landmark Drive, Suite 212 Clearwater, FL 33761 (727) 725-0559 April 4, 11, 2014 14-01972P

FIRST INSERTION

NOTICE OF SALE IN THE CIRCUIT COURT OF THE SIXTH JUDICIAL CIRCUIT IN AND FOR PASCO COUNTY, FLORIDA CIVIL DIVISION CASE NO.: 51-2013-CA-001946-WS SECTION: J2

DANNY B. IPPOLITO and KAREN K. IPPOLITO, husband and wife, Plaintiffs, vs. GEORGE SOFOS and EVANGELINA SOFOS, husband and wife, Defendants.

NOTICE is hereby given that, pursuant to a Uniform Final Judgment of Foreclosure entered in the above captioned case, the Clerk will sell the property situated in Pasco County, Florida, described as:

The East 161.39 feet of Tract 2, UNIT ONE GOLDEN ACRES SUBDIVISION, said portion of tract, unit and subdivision being numbered and designated in accordance with the plat of said subdivision as the same appears of record in Plat Book 7, Page 82 of the Public Records of Pasco County, Florida.

Property Address: 9043 Jasmine Blvd., New Port Richey, Florida 34654

at public sale, to the highest and best bidder for cash, at an online sale at www.pasco.realforeclose.com, beginning at 10:00 a.m. on April 28, 2014.

Any person claiming an interest in the surplus from the sale, if any, other than the property owner as of the date of the Lis Pendens must file a claim within 60 days after the sale.

In accordance with the Americans with Disabilities Act, persons needing a special accommodation to participate in this proceeding should contact the individual or agency sending notice not later than seven (7) days prior to the proceeding at the address given on the notice. Telephone: (904) 257-6097; 1-800-955-8771 (TDD) or 1-800-955-8770 (v), via Florida Relay Service.

DATED this 27th day of March, 2014.

/s/ Walter O. Hobbs Walter O. Hobbs, Esquire For the Court Walter O. Hobbs, Esquire Florida Bar No. 279889

Hobbs and Hobbs, P.L. 3818 W. Azele St. Tampa, Florida 33609 (813) 879-8333 - telephone (813) 877-5426 - facsimile whobbs@hobbsandhobbs.com - email ATTORNEY FOR PLAINTIFFS April 4, 11, 2014 14-02041P

FIRST INSERTION

NOTICE OF SALE PURSUANT TO CHAPTER 45 IN THE CIRCUIT COURT OF THE SIXTH JUDICIAL CIRCUIT IN AND FOR PASCO COUNTY, FLORIDA CIVIL ACTION CASE NO.:

51-2012-CA-007621-CAAX-ES DEUTSCHE BANK NATIONAL TRUST COMPANY, AS TRUSTEE FOR J.P. MORGAN MORTGAGE ACQUISITION TRUST 2007-CH3, ASSET BACKED PASS-THROUGH CERTIFICATES, SERIES 2007-CH3, Plaintiff, vs. O'ROURKE, JAMES et al, Defendant(s).

NOTICE IS HEREBY GIVEN Pursuant to a Final Judgment of Foreclosure dated February 19, 2014, and entered in Case No. 51-2012-CA-007621-CAAX-ES of the Circuit Court of the Sixth Judicial Circuit in and for Pasco County, Florida in which Deutsche Bank National Trust Company, as Trustee for J.P. Morgan Mortgage Acquisition Trust 2007-CH3, Asset Backed Pass-Through Certificates, Series 2007-CH3, is the Plaintiff and Chase Bank USA, N.A., Citifinancial Services, Inc., James O'Rourke, Palm Cove of Wesley Chapel Homeowners Association, Inc., Tina Marie O'Rourke, are defendants, the Pasco County Clerk of the Circuit Court will sell to the highest and best bidder for cash in/on held online www.pasco.realforeclose.com in Pasco County, Florida at 11:00AM on the 21st day of April, 2014, the following described property as set forth in said Final Judgment of Foreclosure:

LOT 7, BLOCK 8, PALM COVE PHASE 1B, ACCORDING TO THE PLAT THEREOF AS RECORDED IN PLAT BOOK 52, PAGES 15 THROUGH 27 INCLUSIVE, OF THE PUBLIC RECORDS, COUNTY OF PASCO,

FLORIDA. 7704 MARINERS HARBOUR DR., WESLEY CHAPEL, FL 33544-4179 Any person claiming an interest in the surplus from the sale, if any, other than the property owner as of the date of the Lis Pendens must file a claim within 60 days after the sale.

If you are a person with a disability who needs an accommodation in order to participate in this proceeding, you are entitled, at no cost to you, to the provision of certain assistance. Please contact: Public Information Dept., Pasco County Government Center 7530 Little Rd. New Port Richey, FL 34654 Phone: 727.847.8110 (voice) in New Port Richey 352.521.4274, ext 8110 (voice) in Dade City Or 711 for the hearing impaired

Contact should be initiated at least seven days before the scheduled court appearance, or immediately upon receiving this notification if the time before the scheduled appearance is less than seven days. The court does not provide transportation and cannot accommodate such requests. Persons with disabilities needing transportation to court should contact their local public transportation providers for information regarding transportation services. Dated in Hillsborough County, Florida, this 27th day of March, 2014 /s/ Erik Del'Etoile Erik Del'Etoile, Esq. FL Bar # 71675 Albertelli Law Attorney for Plaintiff P.O. Box 23028 Tampa, FL 33623 (813) 221-4743 (813) 221-9171 facsimile eService: servealaw@albertellilaw.com BM - 10-55775 April 4, 11, 2014 14-01950P

FIRST INSERTION

NOTICE OF SALE IN THE CIRCUIT COURT OF THE SIXTH JUDICIAL CIRCUIT OF FLORIDA IN AND FOR PASCO COUNTY, FLORIDA CASE NO.:

51-2013-CA-5319-CAAX-WS/H BRANDYWINE CONDOMINIUMS ASSOCIATION OF PASCO COUNTY, INC., a Florida not-for-profit corporation, Plaintiff, vs. ESTATE OF RICHARD F. LORENTZEN AND ANY UNKNOWN HEIRS AND ANY UNKNOWN OCCUPANTS IN POSSESSION, Defendants.

NOTICE IS HEREBY GIVEN that, pursuant to the Summary Final Judgment in this cause, in the County Court of Pasco County, Florida, I will sell all the property situated in Pasco County, Florida described as:

Unit Number 3-B, Brandywine Condominium One, according to the Plat thereof as recorded in Condominium Plat Book 19, Pages 51-54, inclusive, Public Records of Pasco County, Florida, together with an undivided percentage interest or share in the common elements appurtenant thereto, all in accordance with the Declaration of Condominium, and all exhibits attached to said Declaration and by reference made a part hereof, record in Official Records Book 1092, Page 1777-1861, inclusive, Public Records of Pasco County, Florida, as amended by instrument recorded in Official Records Book 1100, Page 1325, Public Records of Pasco County, Florida, as amended by instrument recording in Official Record Book 1107, Page 1477, Public Records of Pasco County, Florida. With the following street address: 7035 Cognac Drive, Unit 2, New Port Richey,

Florida 34653. Property Address: 7035 Cognac Drive, #2, New Port Richey, Florida, 34653.

at public sale, to the highest and best bidder, for cash, at www.pasco.realforeclose.com, at 11:00 A.M. on April 24, 2014.

Any person claiming an interest in the surplus from the sale, if any, other than the property owner as of the date of the lis pendens must file a claim within 60 days after the sale.

If you are a person with a disability who needs any accommodation in order to participate in this proceeding, you are entitled, at no cost to you, to the provision of certain assistance. Please contact the Public Information Dept., Pasco County Government Center, 7530 Little Rd., New Port Richey, FL 34654; (727) 847-8110 (V) in New Port Richey; (352) 521-4274, ext 8110 (V) in Dade City, at least 7 days before your scheduled court appearance, or immediately upon receiving this notification if the time before the scheduled appearance is less than 7 days; if you are hearing impaired call 711. The court does not provide transportation and cannot accommodate for this service. Persons with disabilities needing transportation to court should contact their local public transportation providers for information regarding transportation services. Dated this 27th day of March, 2014. PAULA S. O'NEIL CLERK OF THE CIRCUIT COURT s/ Joseph R. Cianfrone Joseph R. Cianfrone (Joe@attorneyjoe.com) Bar Number 248525 Attorney for Plaintiff Brandywine Condominiums Association of Pasco County, Inc. 1964 Bayshore Boulevard, Suite A Dunedin, Florida 34698 Telephone: (727) 738-1100 April 4, 11, 2014 14-01951P

FIRST INSERTION

NOTICE OF FORECLOSURE SALE IN THE CIRCUIT COURT OF THE SIXTH JUDICIAL CIRCUIT IN AND FOR PASCO COUNTY, FLORIDA GENERAL JURISDICTION DIVISION Case No.:

51-2010-CA-003995-XXXX-ES BAC Home Loans Servicing, LP f/k/a Countrywide Home Loans Servicing, LP, Plaintiff, vs. Renee Sigel; et al Defendants.

NOTICE IS HEREBY GIVEN pursuant to an Order dated March 12, 2014, entered in Case No. 51-2010-CA-003995-XXXX-ES of the Circuit Court of the Sixth Judicial Circuit, in and for Pasco County, Florida, wherein BAC Home Loans Servicing, LP f/k/a Countrywide Home Loans Servicing, LP is the Plaintiff and Renee Sigel; Unknown Spouse of Renee Sigel if any; Any and all Unknown Parties claiming by, through, under, and against the herein named individual Defendant(s) who are not known to be dead or alive, whether said unknown parties may claim an interest as Spouses, Heirs, Devisees, Grantees or other Claimants; John Doe and Jane Doe as Unknown Tenants in Possession Defendant(s) are the Defendants, that the Clerk of Courts will sell to the highest and best bidder for cash by electronic sale at www.pasco.realforeclose.com, beginning at 11:00 AM on the 17th day of April, 2014, the following described property as set forth in said Final Judgment, to wit:

TRACT 475 OF THE UNRECORDED PLAT OF LEISURE HILLS SUBDIVISION, BEING FURTHER DESCRIBED AS FOLLOWS: THE SOUTH

1/2 OF THE NORTHEAST 1/4 OF THE NORTHEAST 1/4 OF THE SOUTHEAST 1/4 OF SECTION 5, TOWNSHIP 24 SOUTH, RANGE 18 EAST, PASCO COUNTY, FLORIDA; LESS THE WESTERN 25 FEET THEREOF FOR ROADWAY PURPOSES. TOGETHER WITH A 1997 DOUBLE-WIDE MOBILE HOME, VIN #S: FLA14610964A AND FLA14610964B.

If you are a person with a disability who needs any accommodation in order to participate in this proceeding, you are entitled, at no cost to you, to the provision of certain assistance. Please contact the Public Information Dept., Pasco County Government Center, 7530 Little Rd., New Port Richey, FL 34654; (727) 847-8110 (V) in New Port Richey; (352) 521-4274, ext 8110 (V) in Dade City, at least 7 days before your scheduled court appearance, or immediately upon receiving this notification if the time before the scheduled appearance is less than 7 days; if you are hearing impaired call 711. The court does not provide transportation and cannot accommodate for this service. Persons with disabilities needing transportation to court should contact their local public transportation providers for information regarding transportation services. Dated this 31st day of March, 2014. By Kathleen E. McCarthy, Esq. FL Bar No. 72161 For: Jimmy Edwards, Esq. Florida Bar No. 81855 BROCK & SCOTT, PLLC Attorney for Plaintiff 1501 N.W. 49th Street, Suite 200 Ft. Lauderdale, FL 33309 Phone: (954) 618-6955, ext. 6105 Fax: (954) 618-6954 FLCourtDocs@brockandscott.com File # 13-F05402 April 4, 11, 2014 14-01995P

OFFICIAL COURTHOUSE WEBSITES: MANATEE COUNTY: www.manateeclerk.com SARASOTA COUNTY: www.sarasotaclerk.com CHARLOTTE COUNTY: www.charlotte.realforeclose.com LEE COUNTY: www.leeclerk.org | COLLIER COUNTY: www.collierclerk.com HILLSBOROUGH COUNTY: www.hillsclerk.com PASCO COUNTY: www.pasco.realforeclose.com PINELLAS COUNTY: www.pinellasclerk.org ORANGE COUNTY: www.myorangeclerk.com Check out your notices on: www.floridapublicnotices.com Business Observer

FIRST INSERTION

NOTICE OF SALE IN THE CIRCUIT CIVIL COURT OF THE SIXTH JUDICIAL CIRCUIT OF FLORIDA, IN AND FOR PASCO COUNTY CIVIL DIVISION  
**Case No. 51-2012-CA-002177WS**  
**Division J2**

**WELLS FARGO BANK, N.A. Plaintiff, vs. JULIE R. AYAZ, UNKNOWN SPOUSE OF JULIE R. AYAZ, AND UNKNOWN TENANTS/OWNERS, Defendants.**

Notice is hereby given, pursuant to Final Judgment of Foreclosure for Plaintiff entered in this cause on March 7, 2014, in the Circuit Court of Pasco County, Florida, Paula O'Neil, Clerk of the Circuit Court, will sell the property situated in Pasco County, Florida described as:

LOT 66, HOLIDAY LAKES WEST UNIT THREE, ACCORDING TO THE MAP OR PLAT THEREOF AS RECORDED IN PLAT BOOK 24, PAGES 64 THROUGH 65, PUBLIC RECORDS OF PASCO COUNTY, FLORIDA.

and commonly known as: 1029 FUCHSIA DRIVE, HOLIDAY, FL 34691; including the building, appurtenances, and fixtures located therein, at public sale, to the highest and best bidder, for cash, www.pasco.realforeclose.com, on April 24, 2014 at 11:00 AM.

Any persons claiming an interest in

the surplus from the sale, if any, other than the property owner as of the date of the lis pendens must file a claim within 60 days after the sale.

If you are a person with a disability who needs any accommodation in order to participate in this proceeding, you are entitled, at no cost to you, to the provision of certain assistance. Please contact the Public Information Dept., Pasco County Government Center, 7530 Little Rd., New Port Richey, FL 34654; (727) 847-8110 (V) in New Port Richey; (352) 521-4274, ext 8110 (V) in Dade City, at least 7 days before your scheduled court appearance, or immediately upon receiving this notification if the time before the scheduled appearance is less than 7 days; if you are hearing impaired call 711. The court does not provide transportation and cannot accommodate for this service. Persons with disabilities needing transportation to court should contact their local public transportation providers for information regarding transportation services.

By: Kari D. Marsland-Pettit, Esq.  
 Attorney for Plaintiff

Invoice to:  
 Kari D. Marsland-Pettit  
 (813) 229-0900 x1509/1359  
 Kass Shuler, P.A.  
 P.O. Box 800  
 Tampa, FL 33601-0800  
 ForeclosureService@kasslaw.com  
 327611/1112204/amm1  
 April 4, 11, 2014 14-01997P

FIRST INSERTION

NOTICE OF SALE IN THE CIRCUIT CIVIL COURT OF THE SIXTH JUDICIAL CIRCUIT OF FLORIDA, IN AND FOR PASCO COUNTY CIVIL DIVISION  
**Case No. 51-2012-CA-003944WS**  
**Division J2**

**WELLS FARGO BANK, N.A. Plaintiff, vs. VICKY L. BLACK AND UNKNOWN TENANTS/OWNERS, Defendants.**

Notice is hereby given, pursuant to Final Judgment of Foreclosure for Plaintiff entered in this cause on March 7, 2014, in the Circuit Court of Pasco County, Florida, Paula O'Neil, Clerk of the Circuit Court, will sell the property situated in Pasco County, Florida described as:

LOT 403, PROPOSED PLAT OF PALM TERRACE GARDENS, UNIT ONE, ACCORDING TO THE PROPOSED PLAT AS RECORDED IN O. R. BOOK 544, PAGE 387, PUBLIC RECORDS OF PASCO COUNTY, FLORIDA.

and commonly known as: 7515 ILEX DRIVE, PORT RICHEY, FL 34668; including the building, appurtenances, and fixtures located therein, at public sale, to the highest and best bidder, for cash, www.pasco.realforeclose.com, on April 24, 2014 at 11:00 AM.

Any persons claiming an interest in the surplus from the sale, if any, other

than the property owner as of the date of the lis pendens must file a claim within 60 days after the sale.

If you are a person with a disability who needs any accommodation in order to participate in this proceeding, you are entitled, at no cost to you, to the provision of certain assistance. Please contact the Public Information Dept., Pasco County Government Center, 7530 Little Rd., New Port Richey, FL 34654; (727) 847-8110 (V) in New Port Richey; (352) 521-4274, ext 8110 (V) in Dade City, at least 7 days before your scheduled court appearance, or immediately upon receiving this notification if the time before the scheduled appearance is less than 7 days; if you are hearing impaired call 711. The court does not provide transportation and cannot accommodate for this service. Persons with disabilities needing transportation to court should contact their local public transportation providers for information regarding transportation services.

By: Lindsay M. Alvarez, Esq.  
 Attorney for Plaintiff

Invoice to:  
 Lindsay M. Alvarez  
 (813) 229-0900 x  
 Kass Shuler, P.A.  
 P.O. Box 800  
 Tampa, FL 33601-0800  
 ForeclosureService@kasslaw.com  
 327611/1114511/amm1  
 April 4, 11, 2014 14-01998P

FIRST INSERTION

NOTICE OF SALE IN THE CIRCUIT COURT OF THE SIXTH JUDICIAL CIRCUIT IN AND FOR PASCO COUNTY, FLORIDA CIVIL DIVISION  
**Case #: 51-2008-CA-006543-ES (J1)**  
**DIVISION: J1**

**Deutsche Bank National Trust Company, as Trustee for Long Beach Mortgage Loan Trust 2006-5 Plaintiff, vs.- Nelson Blanco And Berenice A. Ferrer, Husband And Wife; The Enclave Of Pasco County Homeowners Association, Inc.; Prime Acceptance Corp.; Defendant(s).**

NOTICE IS HEREBY GIVEN pursuant to an Order rescheduling foreclosure sale, entered in Civil Case No. 51-2008-CA-006543-ES (J1) of the Circuit Court of the 6th Judicial Circuit in and for Pasco County, Florida, wherein Deutsche Bank National Trust Company, as Trustee for Long Beach Mortgage Loan Trust 2006-5, Plaintiff and Nelson Blanco And Berenice A. Ferrer, Husband And Wife are defendant(s), I, Clerk of Court, Paula S. O'Neil, will sell to the highest and best bidder for cash in an on-line sale accessed through the Clerk's website at www.pasco.realforeclose.com, at 11:00 a.m. on April 24, 2014, the following described property as set forth in said Final Judgment, to-wit:

LOT 89, THE ENCLAVE,

PHASE 2, AS PER PLAT THEREOF RECORDED IN PLAT BOOK 39, PAGES 39-43, OF THE PUBLIC RECORDS OF PASCO COUNTY, FLORIDA.

ANY PERSON CLAIMING AN INTEREST IN THE SURPLUS FROM THE SALE, IF ANY, OTHER THAN THE PROPERTY OWNER AS OF THE DATE OF THE LIS PENDENS MUST FILE A CLAIM WITHIN 60 DAYS AFTER THE SALE.

If you are a person with a disability who needs any accommodation in order to participate in this proceeding, you are entitled, at no cost to you, to the provision of certain assistance. Please contact the ADA Coordinator; 14250 49th Street North, Clearwater, Florida 33762 (727) 453-7163 at least 7 days before your scheduled court appearance, or immediately upon receiving this notification of the time before the scheduled appearance is less than 7 days. If you are hearing or voice impaired, call 711.

Submitted By:  
 ATTORNEY FOR PLAINTIFF:

SHAPIRO, FISHMAN & GACHÉ, LLP  
 2424 North Federal Highway,  
 Suite 360  
 Boca Raton, Florida 33431  
 (561) 998-6700  
 (561) 998-6707  
 08-104785 FCO1 SPS  
 April 4, 11, 2014 14-02005P

FIRST INSERTION

NOTICE OF RESCHEDULED SALE IN THE CIRCUIT COURT OF THE SIXTH JUDICIAL CIRCUIT IN AND FOR PASCO COUNTY, FLORIDA CIVIL ACTION  
**CASE NO.:**  
**51-2012-CA-002649-CAAX-WS**

**WELLS FARGO BANK, N.A. Plaintiff, vs. HAND, PATRICIA et al, Defendant(s).**

NOTICE IS HEREBY GIVEN Pursuant to an Order Rescheduling Foreclosure Sale dated on or about February 27, 2014, and entered in Case No. 51-2012-CA-002649-CAAX-WS of the Circuit Court of the Sixth Judicial Circuit in and for Pasco County, Florida in which Wells Fargo Bank, N.A. is the Plaintiff and Patricia Hand, are defendants, the Pasco County Clerk of the Circuit Court will sell to the highest and best bidder for cash held online www.pasco.realforeclose.com: in Pasco County, Florida, Pasco County, Florida at 11:00AM on the 23rd day of April, 2014, the following described property as set forth in said Final Judgment of Foreclosure:

LOT 31, REGENCY PARK, UNIT TWO, ACCORDING TO THE MAP OR PLAT THEREOF, AS RECORDED IN PLAT BOOK 11, PAGES 78 AND 79, PUBLIC RECORDS OF PASCO COUNTY, FLORIDA.

7323 HEATH DRIVE, PORT RICHEY, FL 34668-3145  
 Any person claiming an interest in the surplus from the sale, if any, other than the property owner as of the date of the Lis Pendens must file a claim within 60

days after the sale.

If you are a person with a disability who needs an accommodation in order to participate in this proceeding, you are entitled, at no cost to you, to the provision of certain assistance. Please contact:

Public Information Dept., Pasco County Government Center 7530 Little Rd. New Port Richey, FL 34654 Phone: 727.847.8110 (voice) in New Port Richey 352.521.4274, ext 8110 (voice) in Dade City Or 711 for the hearing impaired

Contact should be initiated at least seven days before the scheduled court appearance, or immediately upon receiving this notification if the time before the scheduled appearance is less than seven days.

The court does not provide transportation and cannot accommodate such requests. Persons with disabilities needing transportation to court should contact their local public transportation providers for information regarding transportation services.

Dated in Hillsborough County, Florida, this 28th day of March, 2014

/s/ Erik Del'Etoile  
 Erik Del'Etoile, Esq.  
 FL Bar # 71675

Albertelli Law  
 Attorney for Plaintiff  
 P.O. Box 23028  
 Tampa, FL 33623  
 (813) 221-4743  
 (813) 221-9171 facsimile  
 eService:  
 servealaw@albertellilaw.com  
 BM - 11-76142  
 April 4, 11, 2014 14-01980P

FIRST INSERTION

RE-NOTICE OF FORECLOSURE SALE IN THE CIRCUIT COURT OF THE SIXTH JUDICIAL CIRCUIT, IN AND FOR PASCO COUNTY, FLORIDA CIVIL DIVISION  
**CASE NO.:**  
**51-2012-CA-006560-XXXX-ES**

**CITIMORTGAGE, INC SUCCESSOR BY MERGER TO ABN AMRO MORTGAGE GROUP, INC Plaintiff, vs. JAMES SALCE, et al Defendants.**

RE-NOTICE IS HEREBY GIVEN pursuant to an Order Granting Plaintiff's Motion to Reschedule Foreclosure Sale filed March 18, 2014 and entered in Case No. 51-2012-CA-006560-XXXX-ES of the Circuit Court of the SIXTH Judicial Circuit in and for PASCO COUNTY, Florida, wherein CITIMORTGAGE, INC SUCCESSOR BY MERGER TO ABN AMRO MORTGAGE GROUP, INC, is Plaintiff, and JAMES SALCE, et al are Defendants, the clerk will sell to the highest and best bidder for cash, beginning at 11:00 AM at www.pasco.realforeclose.com, in accordance with Chapter 45, Florida Statutes, on the 24 day of April, 2014, the following described property as set forth in said Lis Pendens, to wit:

Lot 10, Block 13, of Fox Ridge Phase II, Unit I, as per Plat thereof, recorded in Plat Book 18, Page 61, of the Public Records of Pasco County, Florida

Any person claiming an interest in the surplus funds from the sale, if any, other than the property owner as of the

date of the lis pendens must file a claim within 60 days after the sale.

If you are a person with a disability who needs any accommodation in order to participate in this proceeding, you are entitled, at no cost to you, to the provision of certain assistance. Please contact the Public Information Dept., Pasco County Government Center, 7530 Little Rd., New Port Richey, FL 34654; (727) 847-8110 (V) in New Port Richey; (352) 521-4274, ext 8110 (V) in Dade City, at least 7 days before your scheduled court appearance, or immediately upon receiving this notification if the time before the scheduled appearance is less than seven (7) days; if you are hearing or voice impaired, call 711.

The court does not provide transportation and cannot accommodate for this service. Persons with disabilities needing transportation to court should contact their local public transportation providers for information regarding transportation services.

By: /s/ Heather J. Koch  
 Phelan Hallinan, PLC  
 Heather J. Koch, Esq.,  
 Florida Bar No. 89107  
 Emilio R. Lenzi, Esq.,  
 Florida Bar No. 0668273

Phelan Hallinan, PLC  
 Attorneys for Plaintiff  
 2727 West Cypress Creek Road  
 Ft. Lauderdale, FL 33309  
 Tel: 954-462-7000  
 Fax: 954-462-7001  
 Service by email:  
 FL.Service@PhelanHallinan.com  
 PH # 26273  
 April 4, 11, 2014 14-01993P

FIRST INSERTION

NOTICE OF SALE IN THE CIRCUIT CIVIL COURT OF THE SIXTH JUDICIAL CIRCUIT OF FLORIDA, IN AND FOR PASCO COUNTY CIVIL DIVISION  
**Case No. 51-2013-CA-002865 WS**  
**Division J2**

**U.S. BANK NATIONAL ASSOCIATION, AS TRUSTEE FOR J.P. MORGAN MORTGAGE ACQUISITION TRUST 2006-CH2, ASSET BACKED PASS-THROUGH CERTIFICATES, SERIES 2006-CH2 Plaintiff, vs. GEORGE EDWARD HUGHES, II, CHASE BANK USA, N.A., AND UNKNOWN TENANTS/OWNERS, Defendants.**

Notice is hereby given, pursuant to Final Judgment of Foreclosure for Plaintiff entered in this cause on March 7, 2014, in the Circuit Court of Pasco County, Florida, Paula O'Neil, Clerk of the Circuit Court, will sell the property situated in Pasco County, Florida described as:

LOT 1302, UNIT 7-D, JASMINE LAKES SUBDIVISION, SAID LOT, UNIT AND SUBDIVISION BEING NUMBERED AND DESIGNATED IN ACCORDANCE WITH THE PLAT OF SAID SUBDIVISION AS THE SAME APPEARS OF RECORD IN PLAT BOOK 14, PAGES 31 AND 32, PUBLIC RECORDS OF PASCO COUNTY, FLORIDA.

and commonly known as: 7614 ROSEWOOD DRIVE, PORT RICHEY, FL 34668; including the building, appurtenances, and fixtures located therein,

at public sale, to the highest and best bidder, for cash, www.pasco.realforeclose.com, on April 24, 2014 at 11am.

Any persons claiming an interest in the surplus from the sale, if any, other than the property owner as of the date of the lis pendens must file a claim within 60 days after the sale.

If you are a person with a disability who needs any accommodation in order to participate in this proceeding, you are entitled, at no cost to you, to the provision of certain assistance. Please contact the Public Information Dept., Pasco County Government Center, 7530 Little Rd., New Port Richey, FL 34654; (727) 847-8110 (V) in New Port Richey; (352) 521-4274, ext 8110 (V) in Dade City, at least 7 days before your scheduled court appearance, or immediately upon receiving this notification if the time before the scheduled appearance is less than 7 days; if you are hearing impaired call 711. The court does not provide transportation and cannot accommodate for this service. Persons with disabilities needing transportation to court should contact their local public transportation providers for information regarding transportation services.

By: Kari D. Marsland-Pettit, Esq.  
 Attorney for Plaintiff

Invoice to:  
 Kari D. Marsland-Pettit  
 (813) 229-0900 x1509/1359  
 Kass Shuler, P.A.  
 P.O. Box 800  
 Tampa, FL 33601-0800  
 ForeclosureService@kasslaw.com  
 246300/1336716/amm1  
 April 4, 11, 2014 14-02004P

FIRST INSERTION

NOTICE OF RESCHEDULED SALE IN THE CIRCUIT COURT OF THE SIXTH JUDICIAL CIRCUIT IN AND FOR PASCO COUNTY, FLORIDA CIVIL ACTION  
**CASE NO.:**  
**51-2008-CA-001397-CAAX-WS**

**DEUTSCHE BANK NATIONAL TRUST COMPANY, AS TRUSTEE FOR FFMLT TRUST 2006-FF13, MORTGAGE PASS-THROUGH CERTIFICATES, SERIES 2006-FF13, Plaintiff, vs. LANGLAIS, DAVID et al, Defendant(s).**

NOTICE IS HEREBY GIVEN Pursuant to an Order Rescheduling Foreclosure Sale dated on or about March 7, 2014, and entered in Case No. 51-2008-CA-001397-CAAX-WS of the Circuit Court of the Sixth Judicial Circuit in and for Pasco County, Florida in which Deutsche Bank National Trust Company, As Trustee For FFMLT Trust 2006-FF13, Mortgage Pass-through Certificates, Series 2006-FF13, is the Plaintiff and David Langlais, Melissa Sauer, Mortgage Electronic Registration Systems, Inc. acting solely as nominee for First Franklin, a division of National City Bank of In., Pasco County, State of Florida, are defendants, the Pasco County Clerk of the Circuit Court will sell to the highest and best bidder for cash held online www.pasco.realforeclose.com: in Pasco County, Florida at 11:00AM on the 21st day of April, 2014, the following described property as set forth in said Final Judgment of Foreclosure:

LOT 21, LAKEWOOD ESTATES, ACCORDING TO THE PLAT THEREOF, AS RECORDED IN PLAT BOOK 17, PAGES 142 AND 143, OF THE PUBLIC RECORDS OF PASCO COUNTY, FLORIDA.

7825 TEAL DR, NEW PORT RICHEY, FL 34653-4163

Any person claiming an interest in the surplus from the sale, if any, other than the property owner as of the date of the Lis Pendens must file a claim within 60 days after the sale.

If you are a person with a disability who needs an accommodation in order to participate in this proceeding, you are entitled, at no cost to you, to the provision of certain assistance. Please contact:

Public Information Dept., Pasco County Government Center 7530 Little Rd. New Port Richey, FL 34654 Phone: 727.847.8110 (voice) in New Port Richey 352.521.4274, ext 8110 (voice) in Dade City Or 711 for the hearing impaired

Contact should be initiated at least seven days before the scheduled court appearance, or immediately upon receiving this notification if the time before the scheduled appearance is less than seven days.

The court does not provide transportation and cannot accommodate such requests. Persons with disabilities needing transportation to court should contact their local public transportation providers for information regarding transportation services.

Dated in Hillsborough County, Florida, this 27th day of March, 2014

/s/ Erik Del'Etoile  
 Erik Del'Etoile, Esq.  
 FL Bar # 71675

Albertelli Law  
 Attorney for Plaintiff  
 P.O. Box 23028  
 Tampa, FL 33623  
 (813) 221-4743  
 (813) 221-9171 facsimile  
 eService:  
 servealaw@albertellilaw.com  
 BM - 10-42103  
 April 4, 11, 2014 14-01949P

FIRST INSERTION

NOTICE OF SALE IN THE CIRCUIT COURT OF THE SIXTH JUDICIAL CIRCUIT IN AND FOR PASCO COUNTY, FLORIDA CIVIL DIVISION  
**Case #: 51-2012-CA-002179-ES (J1)**  
**DIVISION: J1**

**Bank of America, National Association, Successor by Merger to BAC Home Loans Servicing, LP f/k/a Countrywide Home Loans Servicing LP Plaintiff, vs.- James Clinton Parker a/k/a/ Oscar David Gibson a/k/a James C. Parker and Debbie T. Parker, Husband and Wife; Capital One Bank; Unknown Parties in Possession #1, If living, and all Unknown Parties claiming by, through, under and against the above named Defendant(s) who are not known to be dead or alive, whether said Unknown Parties may claim an interest as Spouse, Heirs, devisees, Grantees, or Other Claimants; Unknown Parties in Possession #2, If living, and all Unknown Parties claiming by, through, under and against the above named Defendant(s) who are not known to be dead or alive, whether said Unknown Parties may claim an interest as Spouse, Heirs, devisees, Grantees, or Other Claimants Defendant(s).**

NOTICE IS HEREBY GIVEN pursuant to a Final Judgment, entered in Civil Case No. 51-2012-CA-002179-ES (J1) of the Circuit Court of the 6th Judicial Circuit in and for Pasco County, Florida, wherein Bank of America, National Association, Successor by Merger to BAC Home Loans Servicing, LP f/k/a Countrywide Home Loans Servicing LP, Plaintiff and James Clinton Parker a/k/a/ Oscar David Gibson a/k/a James C. Parker and Deb-

bie T. Parker, Husband and Wife are defendant(s), I, Clerk of Court, Paula S. O'Neil, will sell to the highest and best bidder for cash in an online sale accessed through the Clerk's website at www.pasco.realforeclose.com, at 11:00 a.m. on May 5, 2014, the following described property as set forth in said Final Judgment, to-wit:

LOT 11, BLOCK 1, FOXWOOD SUBDIVISION PHASE 1, ACCORDING TO THE MAP OR PLAT THEREOF, AS RECORDED IN PLAT BOOK 14, PAGES 113-117, OF THE PUBLIC RECORDS OF PASCO COUNTY, FLORIDA.

ANY PERSON CLAIMING AN INTEREST IN THE SURPLUS FROM THE SALE, IF ANY, OTHER THAN THE PROPERTY OWNER AS OF THE DATE OF THE LIS PENDENS MUST FILE A CLAIM WITHIN 60 DAYS AFTER THE SALE.

If you are a person with a disability who needs any accommodation in order to participate in this proceeding, you are entitled, at no cost to you, to the provision of certain assistance. Please contact the ADA Coordinator; 14250 49th Street North, Clearwater, Florida 33762 (727) 453-7163 at least 7 days before your scheduled court appearance, or immediately upon receiving this notification of the time before the scheduled appearance is less than 7 days. If you are hearing or voice impaired, call 711.

Submitted By:  
 ATTORNEY FOR PLAINTIFF:  
 SHAPIRO, FISHMAN & GACHÉ, LLP  
 2424 North Federal Highway,  
 Suite 360  
 Boca Raton, Florida 33431  
 (561) 998-6700  
 (561) 998-6707  
 11-219550 FCO1 CWF  
 April 4, 11, 2014 14-01956P

FIRST INSERTION

NOTICE OF SALE PURSUANT TO CHAPTER 45 IN THE CIRCUIT COURT OF THE SIXTH JUDICIAL CIRCUIT IN AND FOR PASCO COUNTY, FLORIDA CIVIL ACTION  
**CASE NO.:**  
**51-2012-CA-007931-CAAX-ES**

**U.S. BANK NATIONAL ASSOCIATION NOT IN ITS INDIVIDUAL CAPACITY, BUT SOLELY AS LEGAL TITLE TRUSTEE FOR LVS TITLE TRUST I, Plaintiff, vs. MONDRAGON, NOEL et al, Defendant(s).**

NOTICE IS HEREBY GIVEN Pursuant to a Final Judgment of Foreclosure dated February 19, 2014, and entered in Case No. 51-2012-CA-007931-CAAX-ES of the Circuit Court of the Sixth Judicial Circuit in and for Pasco County, Florida in which U.S. Bank National Association not in its individual capacity, but solely as Legal Title Trustee for LVS Title Trust I, is the Plaintiff and Ana Mondragon, Argent Mortgage Company, LLC, Noel Mondragon, Stonegate of Pasco Homeowners Association, Inc., Tenant #1 nka Steve Hooper, Tenant #2 nka Lauren Hooper, are defendants, the Pasco County Clerk of the Circuit Court will sell to the highest and best bidder for cash in/on held online www.pasco.realforeclose.com: in Pasco County, Florida at 11:00AM on the 21st day of April, 2014, the following described property as set forth in said Final Judgment of Foreclosure:

LOT 22, BLOCK 8, STONEGATE PHASE 1, AS PER PLAT THEREOF RECORDED IN PLAT BOOK 56, PAGE 41 THROUGH 63, INCLUSIVE, OF THE PUBLIC RECORDS OF PASCO COUNTY, FLORIDA.

3032 SILVERMILL LOOP, LAND O LAKES, FL 34639-6068

Any person claiming an interest in the surplus from the sale, if any, other than the property owner as of the date of the Lis Pendens must file a claim within 60 days after the sale.

If you are a person with a disability who needs an accommodation in order to participate in this proceeding, you are entitled, at no cost to you, to the provision of certain assistance. Please contact:

Public Information Dept., Pasco County Government Center 7530 Little Rd. New Port Richey, FL 34654 Phone: 727.847.8110 (voice) in New Port Richey 352.521.4274, ext 8110 (voice) in Dade City Or 711 for the hearing impaired

Contact should be initiated at least seven days before the scheduled court appearance, or immediately upon receiving this notification if the time before the scheduled appearance is less than seven days.

The court does not provide transportation and cannot accommodate such requests. Persons with disabilities needing transportation to court should contact their local public transportation providers for information regarding transportation services.

Dated in Hillsborough County, Florida, this 27th day of March, 2014

/s/ Erik Del'Etoile  
 Erik Del'Etoile, Esq.  
 FL Bar # 71675

Albertelli Law  
 Attorney for Plaintiff  
 P.O. Box 23028  
 Tampa, FL 33623  
 (813) 221-4743  
 (813) 221-9171 facsimile  
 eService:  
 servealaw@albertellilaw.com  
 BM - 11-72866  
 April 4, 11, 2014 14-01960P

FIRST INSERTION

NOTICE OF SALE IN THE CIRCUIT CIVIL COURT OF THE SIXTH JUDICIAL CIRCUIT OF FLORIDA, IN AND FOR PASCO COUNTY

CIVIL DIVISION  
Case No. 51-2012-CA-008314WS  
Division J2

WELLS FARGO BANK, N.A. SUCCESSOR BY MERGER TO WACHOVIA BANK, N.A. Plaintiff, vs.

DWIGHT M. SCHUSTER, DEBORAH J. SCHUSTER, MEADOW OAKS MASTER ASSOCIATION, INC., AND UNKNOWN TENANTS/OWNERS, Defendants.

Notice is hereby given, pursuant to Final Judgment of Foreclosure for Plaintiff entered in this cause on February 26, 2014, in the Circuit Court of Pasco County, Florida, Paula O'Neil, Clerk of the Circuit Court, will sell the property situated in Pasco County, Florida described as:

LOT 4, BLOCK A, MEADOW OAKS UNIT TWO, ACCORDING TO THE PLAT THEREOF, RECORDED IN PLAT BOOK 25, PAGE 121-125 OF THE PUBLIC RECORDS OF PASCO COUNTY, FLORIDA.

and commonly known as: 13253 PRINCE CIRCLE, HUDSON, FL 34669; including the building, appurtenances, and fixtures located therein, at public sale, to the highest and best bidder, for cash, www.pasco.realforeclose.com, on April 23, 2014 at 11:00

AM. Any persons claiming an interest in the surplus from the sale, if any, other than the property owner as of the date of the lis pendens must file a claim within 60 days after the sale.

If you are a person with a disability who needs any accommodation in order to participate in this proceeding, you are entitled, at no cost to you, to the provision of certain assistance. Please contact the Public Information Dept., Pasco County Government Center, 7530 Little Rd., New Port Richey, FL 34654; (727) 847-8110 (V) in New Port Richey; (352) 521-4274, ext 8110 (V) in Dade City, at least 7 days before your scheduled court appearance, or immediately upon receiving this notification if the time before the scheduled appearance is less than 7 days; if you are hearing impaired call 711. The court does not provide transportation and cannot accommodate for this service. Persons with disabilities needing transportation to court should contact their local public transportation providers for information regarding transportation services.

By: Lindsay M. Alvarez, Esq. Attorney for Plaintiff

Invoice to: Lindsay M. Alvarez (813) 229-0900 x Kass Shuler, P.A. P.O. Box 800 Tampa, FL 33601-0800 ForeclosureService@kasslaw.com 309150/1207854/amm1 April 4, 11, 2014 14-01989P

FIRST INSERTION

NOTICE OF SALE IN THE CIRCUIT CIVIL COURT OF THE SIXTH JUDICIAL CIRCUIT OF FLORIDA, IN AND FOR PASCO COUNTY

CIVIL DIVISION  
Case No. 51-2013-CA-001707WS  
Division J3

WELLS FARGO BANK, N.A. Plaintiff, vs. LINDA K. HARVEY A/K/A LINDA HARVEY, STATE OF FLORIDA, DEPARTMENT OF REVENUE, AND UNKNOWN TENANTS/OWNERS, Defendants.

Notice is hereby given, pursuant to Final Judgment of Foreclosure for Plaintiff entered in this cause on March 7, 2014, in the Circuit Court of Pasco County, Florida, Paula O'Neil, Clerk of the Circuit Court, will sell the property situated in Pasco County, Florida described as:

ALL THAT CERTAIN REAL PROPERTY SITUATED IN THE COUNTY OF PASCO STATE OF FLORIDA, DESCRIBED AS FOLLOWS: LOT 132, PALM TERRACE ESTATES, UNIT 5, ACCORDING TO THE MAP OR PLAT THEREOF, AS RECORDED IN PLAT BOOK 9, PAGE 127, OF THE PUBLIC RECORDS OF PASCO COUNTY, FLORIDA.

and commonly known as: 10819 MAPLEWOOD AVENUE, PORT RICHEY, FL 34668; including the building, appurtenances, and fixtures located therein, at public sale, to the highest and best bidder, for cash, www.

pasco.realforeclose.com, on April 23, 2014 at 11am.

Any persons claiming an interest in the surplus from the sale, if any, other than the property owner as of the date of the lis pendens must file a claim within 60 days after the sale.

If you are a person with a disability who needs any accommodation in order to participate in this proceeding, you are entitled, at no cost to you, to the provision of certain assistance. Please contact the Public Information Dept., Pasco County Government Center, 7530 Little Rd., New Port Richey, FL 34654; (727) 847-8110 (V) in New Port Richey; (352) 521-4274, ext 8110 (V) in Dade City, at least 7 days before your scheduled court appearance, or immediately upon receiving this notification if the time before the scheduled appearance is less than 7 days; if you are hearing impaired call 711. The court does not provide transportation and cannot accommodate for this service. Persons with disabilities needing transportation to court should contact their local public transportation providers for information regarding transportation services.

By: David J. Melvin, Esq. Attorney for Plaintiff

Invoice to: David J. Melvin (813) 229-0900 x1327 Kass Shuler, P.A. P.O. Box 800 Tampa, FL 33601-0800 ForeclosureService@kasslaw.com 317300/1330903/amm1 April 4, 11, 2014 14-01990P

FIRST INSERTION

NOTICE OF SALE IN THE CIRCUIT CIVIL COURT OF THE SIXTH JUDICIAL CIRCUIT OF FLORIDA, IN AND FOR PASCO COUNTY

CIVIL DIVISION  
Case No. 51-2013-CA-001978ES  
Division J1

MIDFIRST BANK Plaintiff, vs. ANDREW D. HOWELL A/K/A ANDREW HOWELL, AMY LYNN HOWELL A/K/A AMY HOWELL, DUPREE LAKES HOMEOWNERS ASSOCIATION, INC., AND UNKNOWN TENANTS/OWNERS, Defendants.

Notice is hereby given, pursuant to Final Judgment of Foreclosure for Plaintiff entered in this cause on March 4, 2014, in the Circuit Court of Pasco County, Florida, Paula O'Neil, Clerk of the Circuit Court, will sell the property situated in Pasco County, Florida described as:

LOT 28, BLOCK 3, DUPREE LAKES PHASE 1, ACCORDING TO THE MAP OR PLAT THEREOF, AS RECORDED IN PLAT BOOK 54, PAGES 62 THROUGH 87, INCLUSIVE, OF THE PUBLIC RECORDS OF PASCO COUNTY, FLORIDA.

and commonly known as: 6034 BLUE SAGE DRIVE, LAND O LAKES, FL 34639; including the building, appurtenances, and fixtures located therein, at public sale, to the highest and best bidder, for cash, www.pasco.realforeclose.com, on April 23, 2014

at 11am. Any persons claiming an interest in the surplus from the sale, if any, other than the property owner as of the date of the lis pendens must file a claim within 60 days after the sale.

If you are a person with a disability who needs any accommodation in order to participate in this proceeding, you are entitled, at no cost to you, to the provision of certain assistance. Please contact the Public Information Dept., Pasco County Government Center, 7530 Little Rd., New Port Richey, FL 34654; (727) 847-8110 (V) in New Port Richey; (352) 521-4274, ext 8110 (V) in Dade City, at least 7 days before your scheduled court appearance, or immediately upon receiving this notification if the time before the scheduled appearance is less than 7 days; if you are hearing impaired call 711. The court does not provide transportation and cannot accommodate for this service. Persons with disabilities needing transportation to court should contact their local public transportation providers for information regarding transportation services.

By: David J. Melvin, Esq. Attorney for Plaintiff

Invoice to: David J. Melvin (813) 229-0900 x1327 Kass Shuler, P.A. P.O. Box 800 Tampa, FL 33601-0800 ForeclosureService@kasslaw.com 086150/1332179/amm1 April 4, 11, 2014 14-01996P

FIRST INSERTION

NOTICE OF FORECLOSURE SALE IN THE CIRCUIT COURT OF THE SIXTH JUDICIAL CIRCUIT IN AND FOR PASCO COUNTY, FLORIDA GENERAL JURISDICTION DIVISION

Case No. 2009-CA-007381-ES  
GMAC Mortgage, LLC, Plaintiff, vs. Robert L. Hill; et al. Defendants.

NOTICE IS HEREBY GIVEN pursuant to a Final Judgment of Foreclosure dated February 19, 2014, entered in Case No. 2009-CA-007381-ES of the Circuit Court of the Sixth Judicial Circuit, in and for Pasco County, Florida, wherein GMAC Mortgage, LLC is the Plaintiff and Robert L. Hill; Unknown Spouse of Robert L. Hill if any; Robin Hill a/k/a R.L. Hill; Unknown Spouse of Robin Hill a/k/a R.L. Hill if any; Any and all unknown parties claiming by, through, under, and against the herein named individual defendant(s) who are not known to be dead or alive, whether said unknown parties may claim an interest as spouses, heirs, devisees, grantees, or other claimants; Meadow Pointe III Homeowner's Association, Inc.; Mortgage Electronic Registration Systems, Inc.; John Doe; Jane Doe as Unknown Tenants in Possession are the Defendants, that the Clerk of Courts will sell to the highest and best bidder for cash by electronic sale at www.pasco.realforeclose.com, beginning at 11:00 AM on the 21st day of April, 2014, the following described property as set forth in said Final Judgment, to wit:

LOT 9, BLOCK 3, MEADOW POINTE PARCEL 17, UNIT 2, ACCORDING TO THE MAP OR PLAT THEREOF, AS RECORDED IN PLAT BOOK 37, PAGE 81, OF THE PUBLIC RECORDS OF PASCO COUNTY, FLORIDA.

If you are a person with a disability who needs any accommodation in order to participate in this proceeding, you are entitled, at no cost to you, to the provision of certain assistance. Please contact the Public Information Dept., Pasco County Government Center, 7530 Little Rd., New Port Richey, FL 34654; (727) 847-8110 (V) in New Port Richey; (352) 521-4274, ext 8110 (V) in Dade City, at least 7 days before your scheduled court appearance, or immediately upon receiving this notification if the time before the scheduled appearance is less than 7 days; if you are hearing impaired call 711. The court does not provide transportation and cannot accommodate for this service. Persons with disabilities needing transportation to court should contact their local public transportation providers for information regarding transportation services.

Dated this 27 day of March, 2014. By Kathleen McCarthy, Esq. Florida Bar No. 72161 BROCK & SCOTT, PLLC Attorney for Plaintiff 1501 N.W. 49th Street, Suite 200 Ft. Lauderdale, FL 33309 Phone: (954) 618-6955, ext. 6177 Fax: (954) 618-6954 FLCourtDocs@brockandscott.com 14-F01289 April 4, 11, 2014 14-01969P

FIRST INSERTION

NOTICE OF FORECLOSURE SALE IN THE CIRCUIT COURT OF THE SIXTH JUDICIAL CIRCUIT IN AND FOR PASCO COUNTY, FLORIDA GENERAL JURISDICTION DIVISION

Case No. 51-2013-CA-001382  
The Bank of New York Mellon FKA The Bank of New York Successor Trustee To JPMorgan Chase Bank, N.A., As Trustee For The Structured Asset Mortgage Investments II Trust, Mortgage Pass-Through Certificates, Series 2005-AR7, Plaintiff, vs. Kenneth F. Clarke; et al., Defendants.

NOTICE IS HEREBY GIVEN pursuant to a Final Judgment of Foreclosure dated February 26, 2014, entered in Case No. 51-2013-CA-001382 of the Circuit Court of the Sixth Judicial Circuit, in and for Pasco County, Florida, wherein The Bank of New York Mellon FKA The Bank of New York Successor Trustee To JPMorgan Chase Bank, N.A., As Trustee For The Structured Asset Mortgage Investments II Trust, Mortgage Pass-Through Certificates, Series 2005-AR7 is the Plaintiff and Kenneth F. Clarke; Dianne L. Fec-teau; Bank of America, N.A.; Unknown Tenant #1; Unknown Tenant #2 are the Defendants, that the Clerk of Courts will sell to the highest and best bidder for cash by electronic sale at www.pasco.realforeclose.com, beginning at 11:00 AM on the 23rd day of April, 2014, the following described property as set forth in said

Final Judgment, to wit: LOT 548, FOREST HILLS, UNIT 12, ACCORDING TO THE PLAT THEREOF, AS RECORDED IN PLAT BOOK 9, PAGE 17, OF THE PUBLIC RECORDS OF PASCO COUNTY, FLORIDA.

If you are a person with a disability who needs any accommodation in order to participate in this proceeding, you are entitled, at no cost to you, to the provision of certain assistance. Please contact the Public Information Dept., Pasco County Government Center, 7530 Little Rd., New Port Richey, FL 34654; (727) 847-8110 (V) in New Port Richey; (352) 521-4274, ext 8110 (V) in Dade City, at least 7 days before your scheduled court appearance, or immediately upon receiving this notification if the time before the scheduled appearance is less than 7 days; if you are hearing impaired call 711. The court does not provide transportation and cannot accommodate for this service. Persons with disabilities needing transportation to court should contact their local public transportation providers for information regarding transportation services.

Dated this 28 day of March, 2014. By Kathleen McCarthy, Esq. Florida Bar No. 72161 BROCK & SCOTT, PLLC Attorney for Plaintiff 1501 N.W. 49th Street, Suite 200 Ft. Lauderdale, FL 33309 Phone: (954) 618-6955, ext. 6177 Fax: (954) 618-6954 FLCourtDocs@brockandscott.com 12-F04283 April 4, 11, 2014 14-01979P

FIRST INSERTION

NOTICE OF FORECLOSURE SALE IN THE CIRCUIT COURT OF THE SIXTH JUDICIAL CIRCUIT IN AND FOR PASCO COUNTY, FLORIDA GENERAL JURISDICTION DIVISION

Case No. 512010CA001245WS  
SEC J2  
Innova Investment Group, Inc. Plaintiff, vs. Joaquin Lara a/k/a Joaquin A. Lara ; Evelyn Lara; Asset Acceptance, LLC; Appleton Capital, LLC; Unknown Tenants/Owners; Clerk of Court, Pasco County, Florida State of Florida, Department of Revenue, Defendants.

NOTICE IS HEREBY GIVEN pursuant to a Final Judgment of Foreclosure dated February 17, 2014, entered in Case No. 512010CA001245WS SEC J2 of the Circuit Court of the Sixth Judicial Circuit, in and for Pasco County, Florida, wherein Innova Investment Group, Inc. is the Plaintiff and Joaquin Lara a/k/a Joaquin A. Lara ; Evelyn Lara; Asset Acceptance, LLC; Appleton Capital, LLC; Unknown Tenants/Owners; Clerk of Court, Pasco County, Florida; State of Florida, Department of Revenue are the Defendants, that the Clerk of Courts will sell to the highest and best bidder for cash by electronic sale at www.pasco.realforeclose.com, beginning at 11:00 AM on the 28th day of April, 2014, the following described property as set forth in said Final Judgment, to wit: LOT 736, HOLIDAY GARDENS ESTATES, UNIT FOUR,

ACCORDING TO THE PLAT THEREOF, AS RECORDED IN PLAT BOOK 12, PAGES 1 THROUGH 3, OF THE PUBLIC RECORDS OF PASCO COUNTY, FLORIDA.

If you are a person with a disability who needs any accommodation in order to participate in this proceeding, you are entitled, at no cost to you, to the provision of certain assistance. Please contact the Public Information Dept., Pasco County Government Center, 7530 Little Rd., New Port Richey, FL 34654; (727) 847-8110 (V) in New Port Richey; (352) 521-4274, ext 8110 (V) in Dade City, at least 7 days before your scheduled court appearance, or immediately upon receiving this notification if the time before the scheduled appearance is less than 7 days; if you are hearing impaired call 711. The court does not provide transportation and cannot accommodate for this service. Persons with disabilities needing transportation to court should contact their local public transportation providers for information regarding transportation services.

Dated this 31st day of March, 2014. By Jimmy K. Edwards, Esq. Florida Bar No. 81855 for Jessica Fagen, Esq. Florida Bar No. 50668 BROCK & SCOTT, PLLC Attorney for Plaintiff 1501 N.W. 49th Street, Suite 200 Ft. Lauderdale, FL 33309 Phone: (954) 618-6955, ext. 6105 Fax: (954) 618-6954 FLCourtDocs@brockandscott.com File # 13-F00472 April 4, 11, 2014 14-01994P

FIRST INSERTION

NOTICE OF SALE PURSUANT TO CHAPTER 45 IN THE CIRCUIT COURT OF THE SIXTH JUDICIAL CIRCUIT IN AND FOR PASCO COUNTY, FLORIDA CIVIL ACTION

CASE NO.: 51-2013-CA-000757-CAAX-ES  
WELLS FARGO BANK, NA, Plaintiff, vs. KONIGSBERG, SEYMOUR et al, Defendant(s).

NOTICE IS HEREBY GIVEN Pursuant to a Final Judgment of Foreclosure dated February 19, 2014, and entered in Case No. 51-2013-CA-000757-CAAX-ES of the Circuit Court of the Sixth Judicial Circuit in and for Pasco County, Florida in which Wells Fargo Bank, NA, is the Plaintiff and Saddle Creek Manor Townhomes Homeowners Association, Inc., Seymour Konigsberg also known as Seymour M. Konigsberg, Steven J. Konigsberg, Tenant # 1 also known as Mooupe Kuforiji, are defendants, the Pasco County Clerk of the Circuit Court will sell to the highest and best bidder for cash in/on held online www.pasco.realforeclose.com: in Pasco County, Florida at 11:00AM on the 21st day of April, 2014, the following described property as set forth in said Final Judgment of Foreclosure:

LOT 121, SADDLE CREEK MANOR, ACCORDING TO THE PLAT THEREOF AS RECORDED IN PLAT BOOK 50, PAGE 104, OF THE PUBLIC RECORDS OF PASCO COUNTY, FLORIDA. 5211 BLUE ROAN WAY, WESLEY CHAPEL, FL 33544-1826 Any person claiming an interest in the

surplus from the sale, if any, other than the property owner as of the date of the Lis Pendens must file a claim within 60 days after the sale.

If you are a person with a disability who needs an accommodation in order to participate in this proceeding, you are entitled, at no cost to you, to the provision of certain assistance. Please contact: Public Information Dept., Pasco County Government Center 7530 Little Rd. New Port Richey, FL 34654 Phone: 727.847.8110 (voice) in New Port Richey 352.521.4274, ext 8110 (voice) in Dade City Or 711 for the hearing impaired

Contact should be initiated at least seven days before the scheduled court appearance, or immediately upon receiving this notification if the time before the scheduled appearance is less than seven days.

The court does not provide transportation and cannot accommodate such requests. Persons with disabilities needing transportation to court should contact their local public transportation providers for information regarding transportation services.

Dated in Hillsborough County, Florida, this 28th day of March, 2014 /s/ Erik Del'Etoile Erik Del'Etoile, Esq. FL Bar # 71675 Albertelli Law Attorney for Plaintiff P.O. Box 23028 Tampa, FL 33623 (813) 221-4743 (813) 221-9171 facsimile eService: servealaw@albertellilaw.com BM - 011905F01 April 4, 11, 2014 14-01981P

FIRST INSERTION

NOTICE OF SALE PURSUANT TO CHAPTER 45 IN THE CIRCUIT COURT OF THE SIXTH JUDICIAL CIRCUIT IN AND FOR PASCO COUNTY, FLORIDA CIVIL ACTION

CASE NO.: 51-2013-CA-000660-CAAX-WS  
WELLS FARGO BANK, NA, Plaintiff, vs. SKELTON, RANDALL et al, Defendant(s).

NOTICE IS HEREBY GIVEN Pursuant to a Final Judgment of Foreclosure dated March 5, 2014, and entered in Case No. 51-2013-CA-000660-CAAX-WS of the Circuit Court of the Sixth Judicial Circuit in and for Pasco County, Florida in which Wells Fargo Bank, NA, is the Plaintiff and Randall Skelton, Teena Skelton, are defendants, the Pasco County Clerk of the Circuit Court will sell to the highest and best bidder for cash in/on held online www.pasco.realforeclose.com: in Pasco County, Florida, Pasco County, Florida at 11:00AM on the 23rd day of April, 2014, the following described property as set forth in said Final Judgment of Foreclosure:

LOT 89, GARDEN TERRACE SUBDIVISION SECTION ONE, ACCORDING TO THE PLAT RECORDED IN PLAT BOOK 7, PAGE 23, OF THE PUBLIC RECORDS OF PASCO COUNTY, FLORIDA. 13116 CLERMONT ST HUDSON FL 34667-6832 Any person claiming an interest in the surplus from the sale, if any, other than the property owner as of the date of the

Lis Pendens must file a claim within 60 days after the sale.

If you are a person with a disability who needs an accommodation in order to participate in this proceeding, you are entitled, at no cost to you, to the provision of certain assistance. Please contact:

Public Information Dept., Pasco County Government Center 7530 Little Rd. New Port Richey, FL 34654 Phone: 727.847.8110 (voice) in New Port Richey 352.521.4274, ext 8110 (voice) in Dade City Or 711 for the hearing impaired

Contact should be initiated at least seven days before the scheduled court appearance, or immediately upon receiving this notification if the time before the scheduled appearance is less than seven days.

The court does not provide transportation and cannot accommodate such requests. Persons with disabilities needing transportation to court should contact their local public transportation providers for information regarding transportation services.

Dated in Hillsborough County, Florida, this 28th day of March, 2014 /s/ Erik Del'Etoile Erik Del'Etoile, Esq. FL Bar # 71675 Albertelli Law Attorney for Plaintiff P.O. Box 23028 Tampa, FL 33623 (813) 221-4743 (813) 221-9171 facsimile eService: servealaw@albertellilaw.com JR - 013902F01 April 4, 11, 2014 14-01983P

FIRST INSERTION

NOTICE OF SALE IN THE CIRCUIT COURT OF THE SIXTH JUDICIAL CIRCUIT OF THE STATE OF FLORIDA, IN AND FOR PASCO COUNTY CIVIL DIVISION

CASE NO. 51-2012-CA-006320-XXXX-WS  
EVERBANK, Plaintiff, vs. SHONA R. KISTNER A/K/A SHONA B. KISTNER; UNKNOWN SPOUSE OF SHONA R. KISTNER A/K/A SHONA B. KISTNER; KENNETH K. KISTNER; IF LIVING, INCLUDING ANY UNKNOWN SPOUSE OF SAID DEFENDANT(S), IF REMARRIED, AND IF DECEASED, THE RESPECTIVE UNKNOWN HEIRS, DEVISEES, GRANTEES, ASSIGNEES, CREDITORS, LIENORS, AND TRUSTEES, AND ALL OTHER PERSONS CLAIMING BY, THROUGH, UNDER OR AGAINST THE NAMED DEFENDANT(S); UNKNOWN TENANT #1; UNKNOWN TENANT #2; Defendant(s)

Notice is hereby given that, pursuant to a Final Summary Judgment of Foreclosure entered on 03/05/2014 in the above-styled cause, in the Circuit Court of Pasco County, Florida, the office of Paula S. O'Neil clerk of the circuit court will sell the property situate in Pasco County, Florida, described as: LOT 568 TOGETHER WITH THE WEST 1/2 OF LOT 569 OF THE PROPOSED PLAT OF PALM TERRACE GARDENS, UNIT THREE, ACCORDING TO THE PLAT THEREOF, AS

RECORDED IN OFFICIAL RECORDS BOOK 640, PAGE 324, OF THE PUBLIC RECORDS OF PASCO COUNTY, FLORIDA.

at public sale, to the highest and best bidder, for cash, www.pasco.realforeclose.com at 11:00 o'clock, A.M., on April 21, 2014

Any person claiming an interest in the surplus from the sale, if any, other than the property owner as of the date of the lis pendens, must file a claim within 60 days after the sale.

If you are a person with a disability who needs any accommodation in order to participate in this proceeding, you are entitled, at no cost to you, to the provision of certain assistance. Please contact the Public Information Dept., Pasco County Government Center, 7530 Little Rd., New Port Richey, FL 34654; (727) 847-8110 (V) for proceedings in New Port Richey; (352) 521-4274, ext. 8110 (V) for proceedings in Dade City, at least 7 days before your scheduled court appearance, or immediately upon receiving this notification if the time before the scheduled appearance is less than 7 days; if you are hearing impaired call 711.

Date: 03/31/2014 ATTORNEY FOR PLAINTIFF By /s/ Josh D. Donnelly Josh D. Donnelly Florida Bar #64788 THIS INSTRUMENT PREPARED BY: Law Offices of Daniel C. Consuegra 9204 King Palm Drive Tampa, FL 33619-1328 Phone: 813-915-8660 Attorneys for Plaintiff 136548 April 4, 11, 2014 14-02002P

FIRST INSERTION

NOTICE OF FORECLOSURE SALE IN THE CIRCUIT COURT OF THE SIXTH JUDICIAL CIRCUIT, IN AND FOR PASCO COUNTY, FLORIDA. **CASE NO. 51-2012-CA-008248-XXXX-WS/J2 BANK OF AMERICA, N.A., PLAINTIFF, VS. JEANNE A. HONDLIK, ET AL. DEFENDANT(S).** NOTICE IS HEREBY GIVEN pursuant to the Final Judgment of Foreclosure dated March 20, 2014 in the above action, the Pasco County Clerk of Court will sell to the highest bidder for cash at Pasco, Florida, on June 18, 2014, at 11:00 AM, at www.pasco.realforeclose.com for the following described property:

LOT 53, SOUTHERN OAKS, UNIT ONE, ACCORDING TO THE PLAT THEREOF, RECORDED IN PLAT BOOK 27, AT PAGE 66, OF THE PUBLIC

RECORDS OF PASCO COUNTY, FLORIDA Any person claiming an interest in the surplus from the sale, if any, other than the property owner as of the date of the lis pendens must file a claim within sixty (60) days after the sale. The Court, in its discretion, may enlarge the time of the sale. Notice of the changed time of sale shall be published as provided herein.

If you are a person with a disability who needs any accommodation in order to participate in this proceeding, you are entitled, at no cost to you, to the provision of certain assistance. Please contact the Public Information Department at 727-847-8110 in New Port Richey or 352-521-4274, extension 8110 in Dade City or at Pasco County Government Center, 7530 Little Road, New Port Richey, FL 34654 at least 7 days before your scheduled court appearance, or im-

mediately upon receiving this notification if the time before the scheduled appearance is less than 7 days; if you are hearing or voice impaired, call 711.

The court does not provide transportation and cannot accommodate such requests. Persons with disabilities needing transportation to court should contact their local public transportation providers for information regarding transportation services.

By: J.C. Carrillo, Esq. FBN 753734

Gladstone Law Group, P.A. Attorney for Plaintiff 1499 W. Palmetto Park Road, Suite 300 Boca Raton, FL 33486 1972 BAYW 5296942 BF21370X 10018 Earl 1972 BAYW 5296942 BF21370X 10018 Earl 1978 GLEN 15654351 FL-FL2B832791222 10024 Earl 1978 GLEN 15654352 FLFL-2A832791222 10024 Earl

FIRST INSERTION

NOTICE OF ONLINE SALE IN THE CIRCUIT COURT OF THE SIXTH JUDICIAL CIRCUIT IN AND FOR PASCO COUNTY, FLORIDA CIVIL DIVISION **CASE NO. 51-2011-CA-1480-WS/J3 HARVEY SCHONBRUN, TRUSTEE, Plaintiff, vs. HICKS PARK, INC., a dissolved Florida corporation, and ROBERT L. MOULTON, Defendants.**

Notice is hereby given that, pursuant to a Final Judgment of Foreclosure entered in the above styled cause, in the Circuit Court of Pasco County, Florida, the Office of Paula S. O'Neil, Clerk & Comptroller, will sell the property situate in Pasco County, Florida, described as:

Tract 5 of the unrecorded plat of OAKWOOD ACRES, described as follows: The West 1/4 of the North 1/4 of the South 1/2 of the Northwest 1/4 of Section 31, Township 24 South, Range 17 East, Pasco County, Florida. The Northerly 25' and the Westerly 40' subject to road right of way per O.R. Book 3382, Page 1271. AND Tract 6 of the unrecorded plat of OAKWOOD ACRES, described as follows: The West 1/4 of the South 1/2 of the North 1/2 of the South 1/2 of the Northwest 1/4 of Section 31, Township 24 South, Range 17 East, Pasco County, Florida. The Westerly 40' thereof

subject to easement for public road right of way per O.R. Book 3382, Page 1271. TOGETHER WITH THOSE CERTAIN MOBILE HOMES LOCATED THEREON: Year Make Title# VIN# Address 1989 REBE 46696995 03610301Y 10052 Earl 1983 NOVA 20522566 FG03985A 10036 Woodland 1987 LIBE 45100441 10L20041 10038 Lyons 1976 MALA 13574266 2557A 10037 Lyons 1976 MALA 13574267 2557B 10037 Lyons 1981 SKYL 19914138 01630559AP 10031 Lyons 1981 SKYL 19914139 01630559BP 10031 Lyons 1974 BUDD 10395139 0461982H 10037 Earl 1968 SKYL 3120424 SF1071B 10031 Earl 1973 ADAM 6129823 545 10021 Earl 1974 VILL 11154313 14420 10047 Earl 1974 TRIN 11145766 3000395A 10028 Woodland 1974 TRIN 11145765 3000395B 10028 Woodland 1970 DETR 4275008 GJ021064 10026 Lyons 1983 BEAC 22184788 SSMLAA70026 10030 Lyons 1974 CHEV 11489532 1 1 7 4 L 10025 Lyons 1974 CHEV 11489533 1 1 7 4 R 10025 Lyons 1965 SEVI 2167890 4795 10035 Earl

1985 CYPR 44091523 FHML-0871049 10036 Earl 1985 OAKP 41566966 TWIALAS20622 10041 Earl 1987 KIRK 44237121 14602951 10042 Earl 1983 KIRK 14600762 20628803 10048 Lyons 1972 BAYW 5296941 BF21370U 10018 Earl 1972 BAYW 5296942 BF21370X 10018 Earl 1978 GLEN 15654351 FL-FL2B832791222 10024 Earl 1978 GLEN 15654352 FLFL-2A832791222 10024 Earl

in an electronic sale, to the highest and best bidder, for cash, on April 24, 2014, at 11:00 a.m. at www.pasco.realforeclose.com in accordance with Chapter 45 Florida Statutes.

Any person claiming an interest in the surplus from the sale, if any, other than the property owner as of the date of the lis pendens, must file a claim within 60 days after the sale.

Any person with a disability requiring reasonable accommodation in order to participate in this proceeding should call New Port Richey (727) 847-8100; Dade City (352) 521-4274 ext 8110; TDD 1-800-955-8771 via Florida Relay Service; no later than seven days prior to any proceeding. Dated: March 27, 2014. /s/ Harvey Schonbrun, Esquire HARVEY SCHONBRUN, P. A. 1802 North Morgan Street Tampa, Florida 33602-2328 813/229-0664 phone April 4, 11, 2014 14-01944P

FIRST INSERTION

NOTICE OF FORECLOSURE SALE IN THE CIRCUIT COURT OF THE 6TH JUDICIAL CIRCUIT, IN AND FOR PASCO COUNTY, FLORIDA CIVIL DIVISION **CASE NO. 51-2009-CA-001115-XXXX-ES/J1 DEUTSCHE BANK NATIONAL TRUST COMPANY, AS TRUSTEE OF THE INDYMAC INDX MORTGAGE LOAN TRUST 2005-AR31, MORTGAGE PASS-THROUGH CERTIFICATES, SERIES 2005-AR31 UNDER THE POOLING AND SERVICING AGREEMENT DATED NOVEMBER 1, 2005 Plaintiff, vs. HELEN MEYER AKA HELEN W. MEYER; ET AL; Defendants,**

NOTICE IS HEREBY GIVEN pursuant to a Final Judgment of Foreclosure dated January 28, 2014, and entered in Case No. 51-2009-CA-001115-XXXX-ES/J1, of the Circuit Court of the 6th Judicial Circuit in and for Pasco County, Florida, wherein DEUTSCHE BANK NATIONAL TRUST COMPANY, AS TRUSTEE OF THE INDYMAC INDX MORTGAGE LOAN TRUST 2005-AR31, MORTGAGE PASS-THROUGH CERTIFICATES, SERIES 2005-AR31 UNDER THE POOLING AND SERVICING AGREEMENT DATED NOVEMBER 1, 2005 is Plaintiff and HELEN MEYER AKA HELEN W. MEYER; UNKNOWN SPOUSE OF HELEN W. MEYER; GREGORY B. DE LA RUE; ELIZABETH A. DE LA RUE; CAESAR MEJILLONES; THERESA MEJILLONES; LEILA MEJILLONES; UNKNOWN SPOUSE OF LEILA MEJILLONES; UNKNOWN PERSON(S) IN POSSESSION OF THE SUBJECT PROPERTY; COMPANION PROPERTY AND CASUALTY INSURANCE COMPANY; are defendants. The Clerk of Court will sell to the highest and best bidder for cash by ELECTRONIC SALE AT: WWW.PASCO.REALFORECLOSE.COM, at 11:00 A.M., on the 29 day of April, 2014, the following described property as set forth in said Final Judgment, to wit: THAT PART OF THE SE 1/4

OF THE N/E 1/4 OF THE NE 1/4 OF SECTION 2, TOWNSHIP 25 SOUTH, RANGE 20 EAST, PASCO COUNTY, FLORIDA, LYING SOUTH OF THE SEABOARD COASTLINE RAILROAD RIGHT-OF-WAY, LESS THE SOUTH 250 FEET THEREOF. AND A STRIP OF LAND 100 FEET IN WIDTH THAT IS 50 FEET WIDE ON EACH SIDE OF THE CENTERLINE OF SEABOARD COASTLINE RAILROAD FORMER MAIN TRACK OVER AND ACROSS THE EAST 665 FEET OF THE NE 1/4 OF THE NE 1/4 OF SECTION 2, TOWNSHIP 25 SOUTH, RANGE 20 EAST, PASCO COUNTY, FLORIDA. AND THE NORTH 50 FEET OF THE SOUTH 250 FEET OF THE SE 1/4 OF THE NE 1/4 OF THE NE 1/4 OF SECTION 2, TOWNSHIP 25 SOUTH, RANGE 20 EAST, PASCO COUNTY, FLORIDA. LESS AND EXCEPT A PARCEL OF LAND DESCRIBED AS FOLLOWS: COMMENCE AT THE SOUTHEAST CORNER OF THE NE 1/4 OF THE NE 1/4 OF SECTION 2, TOWNSHIP 25 SOUTH, RANGE 20 EAST, PASCO COUNTY, FLORIDA, RUN THENCE ALONG THE EAST LINE OF SAID NE 1/4 OF NE 1/4, N. 00°06'10" W., 200 FEET FOR A POINT OF BEGINNING; THENCE N. 89°56'26" W., 20 FEET; THENCE N. 00°06'10" W., 250.00 FEET; THENCE N. 43°55' W., 30 FEET; THENCE N. 70°04' W., 120 FEET; THENCE N. 43°42' W., 30 FEET; THENCE N. 16°22' W., 30 FEET; THENCE N. 00°03' W., 11.83 FEET TO THE NORTHERLY RIGHT-OF-WAY LINE OF THE FORMER SEABOARD COASTLINE RAILROAD, THENCE ALONG SAID NORTHERLY RIGHT-OF-WAY LINE OF

A CURVE CONCAVE TO THE SOUTH WITH A CENTRAL ANGLE OF 2°04'30", A RADIUS OF 1482.41 FEET, AN ARC LENGTH OF 53.68 FEET AND CHORD BEARING S. 81°18'55" E., 53.68 FEET; THENCE S. 80°16'40" E. 131.47 FEET TO THE EAST LINE OF SAID NE 1/4 OF NE 1/4; THENCE ALONG SAID EAST LINE S. 00°06'10" E., 344.54 FEET TO THE POINT OF BEGINNING, BEING A PORTION OF THE NE 1/4 OF THE NE 1/4 OF SAID SECTION 2, AND A PORTION OF THE FORMER SEABOARD COASTLINE RAILROAD RIGHT-OF-WAY.

A person claiming an interest in the surplus from the sale, if any, other than the property owner as of the date of the lis pendens must file a claim within 60 days after the sale.

This notice is provided pursuant to Administrative Order 2010-045 PA/PI-CIR "If you are a person with disability who needs any accommodation in order to participate in this proceeding, you are entitled, at no cost to you the provision of certain assistance. Please contact Public Information Dept., Pasco County Government Center, 7530 Little Rd., New Port Richey, FL 34654; (727) 847-8110 (V) for proceedings in New Port Richey; (352) 521-4274, ext. 8110 (V) for proceedings in Dade City at least 7 days before your scheduled court appearance, or immediately upon receiving this notification if the time before the scheduled appearance is less than 7 days; if you are hearing or voice impaired, call 711."

Dated this 27th day of March, 2014. Eric M. Knopp, Esq. Bar. No.: 709921

Submitted by: Kahane & Associates, P.A. 8201 Peters Road, Ste.3000 Plantation, FL 33324 Telephone: (954) 382-3486 Telefacsimile: (954) 382-5380 Designated service email: notice@kahaneandassociates.com File No.: 09-00557 OCN April 4, 11, 2014 14-02019P

FIRST INSERTION

NOTICE OF FORECLOSURE SALE IN THE CIRCUIT COURT IN AND FOR PASCO COUNTY, FLORIDA **CASE NO: 2013CA 004502-WS JPMORGAN CHASE BANK, NATIONAL ASSOCIATION Plaintiff, vs. CHARLES WALTER; JOAN WALTER; UNKNOWN TENANT I; UNKNOWN TENANT II, and any unknown heirs, dedocisees, grantees, creditors, and other unknown persons or unknown spouses claiming by, through and under any of the above-named Defendants, Defendants.**

NOTICE is hereby given that the Clerk of the Circuit Court of Pasco County, Florida, will on the 22nd day of April, 2014, at 11:00 AM, at www.pasco.realforeclose.com, in accordance with Chapter 45 Florida Statutes, offer for sale and sell at public outcry to the

highest and best bidder for cash, the following-described property situate in Pasco County, Florida:

Lot 82, HOLIDAY LAKE ESTATES, UNIT 4, according to the plat thereof as recorded in Plat Book 9, Page 62, Public Records of Pasco County, Florida.

pursuant to the Final Judgment entered in a case pending in said Court, the style of which is indicated above.

Any person or entity claiming an interest in the surplus, if any, resulting from the foreclosure sale, other than the property owner as of the date of the Lis Pendens, must file a claim on same with the Clerk of Court within 60 days after the foreclosure sale.

AMERICANS WITH DISABILITIES ACT. If you are a person with a disability who needs any accommodation in order to participate in this proceeding, you are entitled, at no cost to you, to the provision of certain assistance. Please contact

the Human Rights Office. 400 S. Ft. Harrison Ave., Ste. 500 Clearwater, FL 33756, (727) 464-4880(V) at least 7 days before your scheduled court appearance, or immediately upon receiving this notification if the time before the scheduled appearance is less than 7 days; if you are hearing impaired call 711.

DATED This 31st day of March, 2014. Bridget J. Bullis 0084916

for Chris Bertels, Esquire Florida Bar No: 98267 Charles A. Muniz, Esquire Florida Bar No: 100775

BUTLER & HOSCH, P.A. 3185 South Conway Road, Suite E Orlando, Florida 32812 Telephone: (407) 381-5200 Fax: (407) 381-5577 cm100775@butlerandhosch.com FLpleadings@butlerandhosch.com B&H # 336378 April 4, 11, 2014 14-02022P

FIRST INSERTION

NOTICE OF SALE IN THE CIRCUIT COURT OF THE SIXTH JUDICIAL CIRCUIT OF THE STATE OF FLORIDA, IN AND FOR PASCO COUNTY CIVIL DIVISION **CASE NO. 51-2012-CA-006957-CAAX-WS GREEN TREE SERVICING LLC, Plaintiff, vs. DAVID W. HARTER; SANDRA S. HARTER; BANK OF AMERICA, NATIONAL ASSOCIATION; Defendant(s)**

Notice is hereby given that, pursuant to a Final Summary Judgment of Foreclosure entered on 03/07/2014 in the above-styled cause, in the Circuit Court of Pasco County, Florida, the office of Paula S. O'Neil clerk of the circuit court will sell the property situate in Pasco County, Florida, described as:

LOT 89, BLOCK 268, MOON LAKE ESTATES, UNIT 20, AS PER PLAT THEREOF RECORDED IN PLAT BOOK 7, PAGES 15 THROUGH 17, OF THE PUBLIC RECORDS OF PASCO COUNTY, FLORIDA; AND ALSO INCLUDING: A PORTION OF MOON LAKE AS SHOWN ON PLAT OF MOON LAKE ESTATES, UNIT TWENTY, RECORDED IN PLAT BOOK 7, PAGES 15, 16 AND 17 OF THE PUBLIC RECORDS OF PASCO COUNTY, FLORIDA, BEING MORE PARTICULARLY DESCRIBED AS FOLLOWS: COMMENCE AT THE MOST SOUTHERLY CORNER OF LOT 89, BLOCK 268, OF SAID MOON LAKE ESTATES, UNIT

TWENTY, SAID POINT BEING ON THE NORTHWESTERLY RIGHT OF WAY LINE OF LAKE DRIVE AS NOW ESTABLISHED; THENCE RUN ALONG THE SOUTHERLY BOUNDARY LINE OF SAID LOT 89; NORTH 57 DEGREES WEST, 150.00 FEET TO THE POINT OF BEGINNING; THENCE CONTINUE NORTH 57 DEGREES WEST, 50.00 FEET ALONG THE WESTERLY EXTENSION OF SAID SOUTHERLY BOUNDARY LINE TO A POINT REFERRED TO AS POINT "A"; THENCE ALONG SAID WESTERLY EXTENSION, NORTH 57 DEGREES WEST, 5 FEET MORE OR LESS TO THE APPROXIMATE SHORELINE OF SAID MOON LAKE; THENCE NORTHEASTERLY 72 FEET MORE OR LESS TO THE WESTERLY EXTENSION OF THE NORTHERLY BOUNDARY LINE OF SAID LOT 89; THENCE ALONG SAID WESTERLY EXTENSION, SOUTH 57 DEGREES EAST, 5 FEET MORE OR LESS TO A POINT REFERRED TO AS POINT "B"; SAID POINT BEING LOCATED NORTH 20 DEGREES 54'19" EAST, 71.59 FEET FORM SAID POINT "A"; THENCE ALONG SAID WESTERLY EXTENSION, SOUTH 57 DEGREES EAST, 65.00 FEET TO THE MOST NORTHERLY CORNER OF SAID LOT 89; THENCE ALONG THE WESTERLY BOUNDARY LINE OF

SAID LOT 89, SOUTH 33 DEGREES WEST, 70.00 FEET TO THE POINT OF BEGINNING. at public sale, to the highest and best bidder, for cash, www.pasco.realforeclose.com at 11:00 o'clock, A.M., on April 22, 2014

Any person claiming an interest in the surplus from the sale, if any, other than the property owner as of the date of the lis pendens, must file a claim within 60 days after the sale.

If you are a person with a disability who needs any accommodation in order to participate in this proceeding, you are entitled, at no cost to you, to the provision of certain assistance. Please contact the Public Information Dept., Pasco County Government Center, 7530 Little Rd., New Port Richey, FL 34654; (727) 847-8110 (V) for proceedings in New Port Richey; (352) 521-4274, ext. 8110 (V) for proceedings in Dade City, at least 7 days before your scheduled court appearance, or immediately upon receiving this notification if the time before the scheduled appearance is less than 7 days; if you are hearing impaired call 711.

Date: 04/01/2014 ATTORNEY FOR PLAINTIFF By /S/ Josh D. Donnelly Josh D. Donnelly Florida Bar #64788

THIS INSTRUMENT PREPARED BY: Law Offices of Daniel C. Consuegra 9204 King Palm Drive Tampa, FL 33619-1328 Phone: 813-915-8660 Attorneys for Plaintiff 128830 April 4, 11, 2014 14-02028P

FIRST INSERTION

NOTICE OF SALE IN THE CIRCUIT COURT OF THE SIXTH JUDICIAL CIRCUIT OF THE STATE OF FLORIDA, IN AND FOR PASCO COUNTY CIVIL DIVISION **CASE NO. 51-2012-CA-004666-CAAX-WS HSBC BANK USA, NATIONAL ASSOCIATION AS TRUSTEE FOR OPTIMUM MORTGAGE ACCEPTANCE CORPORATION, ASSET-BACKED PASS-THROUGH CERTIFICATES, SERIES 2005-5, Plaintiff, vs. UNKNOWN HEIRS, DEVISEES, GRANTEES, ASSIGNEES, CREDITORS, LIENORS, TRUSTEES OF JOAN BERNARD A/K/A JOAN A. BERNARD, DECEASED; CYNTHIA TRUMP, HEIR; IF LIVING, INCLUDING ANY UNKNOWN SPOUSE OF SAID DEFENDANT(S), IF REMARRIED, AND IF DECEASED, THE RESPECTIVE UNKNOWN HEIRS, DEVISEES, GRANTEES, ASSIGNEES, CREDITORS, LIENORS, AND ALL OTHER PERSONS CLAIMING BY, THROUGH, UNDER OR AGAINST THE NAMED DEFENDANT(S); MORTGAGE ELECTRONIC REGISTRATION SYSTEMS, INC., AS NOMINEE FOR OPTIMUM FINANCIAL SERVICES, INC. ; WHETHER DISSOLVED OR PRESENTLY EXISTING, TOGETHER WITH ANY GRANTEES, ASSIGNEES, CREDITORS, LIENORS, OR TRUSTEES OF SAID DEFENDANT(S) AND ALL OTHER PERSONS CLAIMING BY, THROUGH, UNDER, OR AGAINST DEFENDANT(S); UNKNOWN TENANT #1; UNKNOWN TENANT #2; Defendant(s)**

Notice is hereby given that, pursuant to a Final Summary Judgment of Foreclosure entered on 03/07/2014 in the above-styled cause, in the Circuit Court of Pasco County, Florida, the office of Paula S. O'Neil clerk of the circuit court will sell the property situate in Pasco County, Florida, described as: LOT 26, BAYWOOD FOREST, UNIT ONE, ACCORDING TO THE PLAT THEREOF, RECORDED IN PLAT BOOK 15, PAGES 146 THROUGH 149, OF THE PUBLIC RECORDS OF PASCO COUNTY, FLORIDA, LESS THAT POR-

TION THAT WAS DEEDED TO PASCO COUNTY RECORDED IN O.R. BOOK 7734 PAGE 125, BEING MORE PARTICULARLY DESCRIBED AS FOLLOWS: COMMENCE AT THE SOUTHEAST CORNER OF THE SOUTHEAST 1/4 OF SAID SECTION 8, THENCE SOUTH 89°25'27" WEST ALONG THE SOUTH LINE OF SAID SOUTHEAST 1/4, A DISTANCE OF 945.68 FEET TO A POINT ON THE PROJECT CENTERLINE OF SURVEY OF MOON LAKE ROAD (COUNTY ROAD 587), (PROJECT NUMBER C9528.00), SAID POINT BEING STATION 1586+06.48 TO A POINT ON A CIRCULAR CURVE CONCAVE TO THE SOUTHEAST AND HAVING A RADIUS OF 2,546.00 FEET AND A CHORD BEARING OF NORTH 13°59'07" EAST; THENCE RUN ALONG THE PROJECT CENTERLINE OF SURVEY, ALONG THE ARC OF SAID CURVE THROUGH A CENTRAL ANGLE OF 15°51'30" FOR A DISTANCE OF 704.68 FEET; THENCE NORTH 72°44'31" WEST, A DISTANCE OF 81.68 FEET TO THE NORTHEAST CORNER OF LOT 26; CONTINUE THENCE NORTH 72°44'31" WEST ALONG THE NORTHEASTERLY LINE OF SAID LOT 26, A DISTANCE OF 28.59 FEET TO THE WESTERLY RIGHT-OF-WAY LINE OF OLD MOON LAKE ROAD PER PLAT MOON LAKE ESTATES UNIT THREE, PLAT BOOK 4, PAGES 75 AND 76; THENCE SOUTH 02°46'22" WEST ALONG SAID WESTERLY RIGHT-OF-WAY LINE OF OLD MOON LAKE ROAD RIGHT-OF-WAY, A DISTANCE OF 31.06 FEET TO THE POINT OF BEGINNING; CONTINUE THENCE SOUTH 02°46'22" WEST ALONG SAID WESTERLY RIGHT-OF-WAY LINE OF OLD MOON LAKE ROAD RIGHT-OF-WAY, A DISTANCE OF 89.00 FEET TO THE SOUTHEASTERLY LINE OF LOT 26, SAID POINT BEING ON A CURVE CONCAVE TO THE SOUTHEAST AND HAVING A RADIUS OF 2198.59 FEET AND A CHORD

BEARING OF SOUTH 14°30'25" WEST; THENCE ALONG THE SOUTHEASTERLY LINE OF LOT 26, ALONG THE ARC OF SAID CURVE THROUGH A CENTRAL ANGLE OF 01°03'10" FOR A DISTANCE OF 40.40 FEET TO THE SOUTHERN MOST CORNER OF LOT 26; THENCE NORTH 72°58'03" WEST ALONG THE SOUTHWESTERLY LINE OF LOT 26, A DISTANCE OF 29.63 FEET, TO A POINT ON A CURVE CONCAVE TO THE EAST AND HAVING A RADIUS OF 2646.00 FEET AND A CHORD BEARING OF NORTH 19°42'45" EAST; THENCE ALONG THE ARC OF SAID CURVE THROUGH A CENTRAL ANGLE OF 02°44'42" FOR A DISTANCE OF 126.77 FEET OF THE POINT OF BEGINNING.

at public sale, to the highest and best bidder, for cash, www.pasco.realforeclose.com at 11:00 o'clock, A.M., on April 24, 2014

Any person claiming an interest in the surplus from the sale, if any, other than the property owner as of the date of the lis pendens, must file a claim within 60 days after the sale.

If you are a person with a disability who needs any accommodation in order to participate in this proceeding, you are entitled, at no cost to you, to the provision of certain assistance. Please contact the Public Information Dept., Pasco County Government Center, 7530 Little Rd., New Port Richey, FL 34654; (727) 847-8110 (V) for proceedings in New Port Richey; (352) 521-4274, ext. 8110 (V) for proceedings in Dade City, at least 7 days before your scheduled court appearance, or immediately upon receiving this notification if the time before the scheduled appearance is less than 7 days; if you are hearing impaired call 711.

Date: 04/01/2014 ATTORNEY FOR PLAINTIFF By /S/ Josh D. Donnelly Josh D. Donnelly Florida Bar #64788

THIS INSTRUMENT PREPARED BY: Law Offices of Daniel C. Consuegra 9204 King Palm Drive Tampa, FL 33619-1328 Phone: 813-915-8660 Attorneys for Plaintiff 125980 April 4, 11, 2014 14-02025P

FIRST INSERTION

NOTICE OF FORECLOSURE SALE IN THE CIRCUIT COURT OF THE SIXTH JUDICIAL CIRCUIT, IN AND FOR PASCO COUNTY, FLORIDA

51-2013-CA-004399-CAAX-ES NATIONSTAR MORTGAGE LLC, Plaintiff, vs. ALEXANDER VAZQUEZ, et al. Defendants NOTICE IS HEREBY GIVEN pursuant to a Final Judgment of Foreclosure dated March 19, 2014, and entered in Case No. 51-2013-CA-004399-CAAX-ES, of the Circuit Court of the Sixth Judicial Circuit in and for PASCO County, Florida.

surplus from the sale, if any, other than the property owner as of the date of the Lis Pendens must file a claim within 60 days after the sale.

If you are a person with a disability who needs an accommodation in order to participate in this proceeding, you are entitled, at no cost to you, to the provision of certain assistance. Please contact: Public Information Dept., Pasco County Government Center, 7530 Little Rd., New Port Richey, FL 34654; Phone: 727.847.8110

Mark C. Elia, Esq. Florida Bar #: 695734 Email: MCElia@vanlawfl.com VAN NESS LAW FIRM, PLC 1239 E. Newport Center Drive, Suite 110 Deerfield Beach, Florida 33442 Ph: (954) 571-2031 Fax: (954) 571-2033 PRIMARY EMAIL: Pleadings@vanlawfl.com April 4, 11, 2014 14-02010P

FIRST INSERTION

NOTICE OF SALE IN THE CIRCUIT CIVIL COURT OF THE SIXTH JUDICIAL CIRCUIT OF FLORIDA, IN AND FOR PASCO COUNTY

CIVIL DIVISION Case No. 51-2012-CA-007833WS Division J2 WELLS FARGO BANK, N.A. Plaintiff, vs. MONICA A. SPRINGER A/K/A MONICA SPRINGER, SHADOW RIDGE HOMEOWNERS' ASSOCIATION, INC., JAMES W. SPRINGER, USAA FEDERAL SAVINGS BANK ("USAA FSB"), CHASE BANK USA, N.A., AND UNKNOWN TENANTS/OWNERS, Defendants.

Notice is hereby given, pursuant to Final Judgment of Foreclosure for Plaintiff entered in this cause on January 16, 2014, in the Circuit Court of Pasco County, Florida, Paula O'Neil, Clerk of the Circuit Court, will sell the property situated in Pasco County, Florida described as:

LOT 141, SHADOW RIDGE, ACCORDING TO THE PLAT THEREOF AS RECORDED IN PLAT BOOK 17, PAGES 41-43, PUBLIC RECORDS OF PASCO COUNTY, FLORIDA.

and commonly known as: 12116 SHADOW RIDGE BLVD, HUDSON, FL 34669; including the building, appurtenances, and fixtures located therein, at public sale, to the highest and best bidder, for cash, www.pasco.realforeclose.com, on April 25, 2014 at

11:00 AM. Any persons claiming an interest in the surplus from the sale, if any, other than the property owner as of the date of the lis pendens must file a claim within 60 days after the sale.

If you are a person with a disability who needs any accommodation in order to participate in this proceeding, you are entitled, at no cost to you, to the provision of certain assistance. Please contact the Public Information Dept., Pasco County Government Center, 7530 Little Rd., New Port Richey, FL 34654; (727) 847-8110 (V) in New Port Richey; (352) 521-4274, ext 8110 (V) in Dade City, at least 7 days before your scheduled court appearance, or immediately upon receiving this notification if the time before the scheduled appearance is less than 7 days; if you are hearing impaired call 711. The court does not provide transportation and cannot accommodate for this service. Persons with disabilities needing transportation to court should contact their local public transportation providers for information regarding transportation services.

By: Michael L. Tebbi, Esq. Attorney for Plaintiff

Invoice to: Michael L. Tebbi (813) 229-0900 x1346 Kass Shuler, P.A. P.O. Box 800 Tampa, FL 33601-0800 ForeclosureService@kasslaw.com 327611/1216804/amml April 4, 11, 2014 14-02014P

FIRST INSERTION

NOTICE OF FORECLOSURE SALE IN THE CIRCUIT COURT OF THE SIXTH JUDICIAL CIRCUIT, IN AND FOR PASCO COUNTY, FLORIDA

CASE NO. 51-2009-CA-002189-ES COUNTRYWIDE HOME LOANS SERVICING, L.P., Plaintiff, vs. MARSHA S. SZYSZKA; SHARON ARAD, et al. Defendants

NOTICE IS HEREBY GIVEN pursuant to a Final Judgment of Foreclosure dated March 26, 2014, and entered in Case No. 51-2009-CA-002189-ES, of the Circuit Court of the Sixth Judicial Circuit in and for PASCO County, Florida. BANK OF AMERICA, N.A. is Plaintiff and MARSHA S. SZYSZKA; SHARON ARAD; BALLANTRAE HOMEOWNERS ASSOCIATION, INC, are defendants. Clerk of Court will sell to the highest and best bidder for cash via the Internet at www.pasco.realforeclose.com, at 11:00 a.m., on the 13th day of May, 2014, the following described property as set forth in said Final Judgment, to wit:

LOT 76, BLOCK 1, OF BALLANTRAE VILLAGE 6, ACCORDING TO THE PLAT THEREOF, RECORDED IN PLAT BOOK 53, PAGE 1 THROUGH 10, INCLUSIVE OF THE PUBLIC RECORDS OF PASCO COUNTY, FLORIDA.

Any person claiming an interest in the surplus from the sale, if any, other than

the property owner as of the date of the Lis Pendens must file a claim within 60 days after the sale.

If you are a person with a disability who needs an accommodation in order to participate in this proceeding, you are entitled, at no cost to you, to the provision of certain assistance. Please contact: Public Information Dept., Pasco County Government Center, 7530 Little Rd., New Port Richey, FL 34654; Phone: 727.847.8110 (voice) in New Port Richey, 352.521.4274, ext 8110 (voice) in Dade City, Or 711 for the hearing impaired. Contact should be initiated at least seven days before the scheduled court appearance, or immediately upon receiving this notification if the time before the scheduled appearance is less than seven days. The court does not provide transportation and cannot accommodate such requests. Persons with disabilities needing transportation to court should contact their local public transportation providers for information regarding transportation services.

Mark C. Elia, Esq. Florida Bar #: 695734 Email: MCElia@vanlawfl.com

VAN NESS LAW FIRM, PLC 1239 E. Newport Center Drive, Suite 110 Deerfield Beach, Florida 33442 Ph: (954) 571-2031 Fax: (954) 571-2033 PRIMARY EMAIL: Pleadings@vanlawfl.com OC6586-13/ee April 4, 11, 2014 14-02016P

FIRST INSERTION

NOTICE OF RESCHEDULED SALE IN THE CIRCUIT COURT OF THE SIXTH JUDICIAL CIRCUIT IN AND FOR PASCO COUNTY, FLORIDA

CIVIL ACTION CASE NO.: 51-2010-CA-002801-CAAX-WS DIVISION: 15

NATIONSTAR MORTGAGE, LLC, Plaintiff, vs. DEWITT, JAMES E. et al, Defendant(s).

NOTICE IS HEREBY GIVEN Pursuant to an Order Rescheduling Foreclosure Sale dated on or about March 17, 2014, and entered in Case No. 51-2010-CA-002801-CAAX-WS of the Circuit Court of the Sixth Judicial Circuit in and for Pasco County, Florida in which Nationstar Mortgage, LLC, is the Plaintiff and James E. Dewitt, are defendants, the Pasco County Clerk of the Circuit Court will sell to the highest and best bidder for cash held online www.pasco.realforeclose.com: in Pasco County, Florida, Pasco County, Florida at 11:00AM on the 25th day of April, 2014, the following described property as set forth in said Final Judgment of Foreclosure:

LOT 3, HOLIDAY GARDENS, UNIT ONE, ACCORDING TO THE PLAT THEREOF AS RECORDED IN PLAT BOOK 9, PAGE 25, OF THE PUBLIC RECORDS OF PASCO COUNTY, FLORIDA.

2208 ARCADIA RD, HOLIDAY, FL 34690-4311 Any person claiming an interest in the surplus from the sale, if any, other than the property owner as of the date of the

Lis Pendens must file a claim within 60 days after the sale.

If you are a person with a disability who needs an accommodation in order to participate in this proceeding, you are entitled, at no cost to you, to the provision of certain assistance. Please contact:

Public Information Dept., Pasco County Government Center 7530 Little Rd. New Port Richey, FL 34654 Phone: 727.847.8110 (voice) in New Port Richey 352.521.4274, ext 8110 (voice) in Dade City Or 711 for the hearing impaired

Contact should be initiated at least seven days before the scheduled court appearance, or immediately upon receiving this notification if the time before the scheduled appearance is less than seven days.

The court does not provide transportation and cannot accommodate such requests. Persons with disabilities needing transportation to court should contact their local public transportation providers for information regarding transportation services.

Dated in Hillsborough County, Florida, this 30th day of March, 2014

/s/ Megan Roach Megan Roach, Esq. FL Bar # 103150

Albertelli Law Attorney for Plaintiff P.O. Box 23028 Tampa, FL 33623 (813) 221-4743 (813) 221-9171 facsimile eService: servealaw@albertellilaw.com BM - 10-63746 April 4, 11, 2014 14-02006P

FIRST INSERTION

NOTICE OF FORECLOSURE SALE IN THE CIRCUIT COURT OF THE SIXTH JUDICIAL CIRCUIT OF FLORIDA IN AND FOR PASCO COUNTY

GENERAL JURISDICTION DIVISION CASE NO. 2012-CA-007016-WS

FLAGSTAR BANK, FSB, Plaintiff, vs. AARON MITCHELL, et al., Defendants.

NOTICE IS HEREBY GIVEN pursuant to a Summary Final Judgment of Foreclosure entered March 14, 2014 in Civil Case No. 2012-CA-007016-WS of the Circuit Court of the SIXTH Judicial Circuit in and for Pasco County, Dade City, Florida, wherein FLAGSTAR BANK, FSB is Plaintiff and AARON MITCHELL, ORCHID LAKE VILLAGE CIVIC ASSOCIATION, INC., JESSICA MITCHELL, UNKNOWN TENANT IN POSSESSION # 1 N/K/A GUY T. WILSON, UNKNOWN TENANT IN POSSESSION # 2 N/K/A CHARITY DAVIDSON, are Defendants, the Clerk of Court will sell to the highest and best bidder for cash electronically at www.pasco.realforeclose.com in accordance with Chapter 45, Florida Statutes on the 29th day of April, 2014 at 11:00 AM on the following described property as set forth in said Summary Final Judgment, to-wit:

Lot 27, ORCHID LAKE VILLAGE UNIT ONE, according to the map or plat thereof, as recorded in Plat Book 17, Page 64, of the Public Records of Pasco

County, Florida. Any person claiming an interest in the surplus from the sale, if any, other than the property owner as of the date of the lis pendens, must file a claim within 60 days after the sale.

If you are a person with a disability who needs any accommodation in order to participate in this proceeding, you are entitled, at no cost to you to the provision of certain assistance. Within two (2) working days of your receipt of this (describe notice/order) please contact the Public Information Dept., Pasco County Government Center, 7530 Little Rd., New Port Richey, FL 34654; (727) 847-8110 (V) in New Port Richey; (352) 521-4274, ext. 8110 (V) in Dade City; via 1-800-955-8771 if you are hearing impaired. The court does not provide transportation and cannot accommodate for this service. Persons with disabilities needing transportation to court should contact their local public transportation providers for information regarding disabled transportation services.

ROBYN KATZ FLORIDA BAR NO.: 0146803 Brian Hummel, Esq. Fla. Bar No.: 46162

McCalla Raymer, LLC Attorney for Plaintiff 225 E. Robinson St. Suite 660 Orlando, FL 32801 Phone: (407) 674-1850 Fax: (321) 248-0420 Email: MRService@mccallaraymer.com 2634438 12-01665-5 April 4, 11, 2014 14-02009P

FIRST INSERTION

NOTICE OF SALE PURSUANT TO CHAPTER 45 IN THE CIRCUIT COURT OF THE SIXTH JUDICIAL CIRCUIT IN AND FOR PASCO COUNTY, FLORIDA

GENERAL JURISDICTION DIVISION CASE NO.

51-2013-CA-004204-XXXX-ES Tierra Del Sol Homeowner's Association, Inc., a Florida Non Profit Corporation, Plaintiff, v.

Michael E. Lindo, and any Unknown Heirs, devisees, Grantees, Creditors and Other Unknown Persons or Unknown Spouses Claiming By, Through and Under Michael E. Lindo, Defendant(s).

NOTICE OF SALE IS HEREBY GIVEN pursuant to an Order of Final Judgment of Foreclosure dated March 26, 2014 and entered in Case No. 51-2013-CA-004204-XXXX-ES of the Circuit Court of the Sixth Judicial Circuit in and for Pasco County, Florida wherein Tierra Del Sol Homeowner's Association, Inc., is Plaintiff, and Michael E. Lindo is the Defendants, the Clerk of Court will sell to the highest and best bidder for cash on www.pasco.realforeclose.com at 11:00 o'clock A.M. on the 12th day of May, 2014, the following described property as set forth in said Order of Final Judgment to wit:

LOT 38, BLOCK 18, TIERRA DEL SOL PHASE 1, ACCORDING TO THE MAP OR PLAT THEREOF RECORDED IN PLAT BOOK 52, PAGES 70 THROUGH 84, INCLUSIVE, PUBLIC RECORDS OF PASCO

COUNTY, FLORIDA. Property Address: 9304 Zincoe Lane, Land O'Lakes, FL 34638

Any person claiming an interest in the surplus from the sale, if any, other than the property owner as of the date of the Lis Pendens must file a claim within sixty (60) Days after the sale.

AMERICANS WITH DISABILITIES ACT ASSISTANCE

If you are a person with a disability who needs any accommodation in order to participate in this proceeding, you are entitled, at no cost to you, to the provision of certain assistance. Please contact the Public Information Dept., Pasco County Government Center, 7530 Little Rd., New Port Richey, FL 34654; (727) 847-8110 (V) in New Port Richey; (352) 521-4274, ext 8110 (V) in Dade City, at least 7 days before your scheduled court appearance, or immediately upon receiving this notification if the time before the scheduled appearance is less than 7 days; if you are hearing impaired call 711. The court does not provide transportation and cannot accommodate for this service. Persons with disabilities needing transportation to court should contact their local public transportation providers for information regarding transportation services.

Dated this 31 day of MARCH, 2014. Luis R. Lasa III, Esq. Florida Bar No.: 56179

Association Law Group, P.L. Attorney for Plaintiff P.O. Box 311059 Miami, FL 33231 (305)938-6922 Telephone (305)938-6914 Facsimile April 4, 11, 2014 14-02013P

FIRST INSERTION

NOTICE OF FORECLOSURE SALE IN THE CIRCUIT COURT OF THE SIXTH JUDICIAL CIRCUIT IN AND FOR PASCO COUNTY, FLORIDA

CIVIL DIVISION Case No.: 51-2011-CA-006203ES Division: J4

PROVIDENT FUNDING ASSOCIATES, L.P. Plaintiff, v. MICHAEL E. CARDWELL A/K/A MICHAEL EARL CARDWELL; ET AL, Defendants,

NOTICE IS HEREBY GIVEN pursuant to a Final Judgment March 12, 2013, entered in Civil Case No.: 51-2011-CA-006203ES, DIVISION: J4, of the Circuit Court of the Sixth Judicial Circuit in and for Pasco County, Florida, wherein PROVIDENT FUNDING ASSOCIATES, L.P. is Plaintiff, and MICHAEL E. CARDWELL A/K/A MICHAEL EARL CARDWELL; VALERIE CARDWELL; UNKNOWN TENANT #1; UNKNOWN TENANT #2; ALL OTHER UNKNOWN PARTIES CLAIMING INTERESTS BY, THROUGH, UNDER, AND AGAINST A NAMED DEFENDANT(S) WHO ARE NOT KNOWN TO BE DEAD OR ALIVE, WHETHER SAME UNKNOWN PARTIES MAY CLAIM AN INTEREST AS SPOUSES, HEIRS, DEVISEES, GRANTEES, OR OTHER CLAIMANTS, are Defendants. PAULA S. O'NEIL, Clerk of the Court, will sell to the highest bidder for cash at 11:00 a.m. online at www.pasco.realforeclose.com on the 21st day of April, 2014 the following described real property as set forth in said Final Judgment, to wit:

RECORDED IN PLAT BOOK 25, PAGE 97 THROUGH 100, INCLUSIVE, PUBLIC RECORDS OF PASCO COUNTY, FLORIDA.

If you are a person claiming a right to funds remaining after the sale, you must file a claim with the clerk no later than 60 days after the sale. If you fail to file a claim you will not be entitled to any remaining funds. After 60 days, only the owner of record as of the date of the lis pendens may claim the surplus.

If you are a person with a disability who needs an accommodation in order to participate in this proceeding, you are entitled, at no cost to you, to the provision of certain assistance. Please contact: Public Information Dept., Pasco County Government Center, 7530 Little Rd., New Port Richey, FL 34654. Phone: 727.847.8110 (voice) in New Port Richey 352.521.4274, ext 8110 (voice) in Dade City or 711 for the hearing impaired. Contact should be initiated at least seven days before the scheduled court appearance, or immediately upon receiving this notification if the time before the scheduled appearance is less than seven days

Dated this 26 day of March, 2014. /s/ Joshua Sabet By: Joshua Sabet, Esquire Fla. Bar No.: 85356 Primary Email: JSabet@ErwLaw.com Secondary Email: docservice@erwlaw.com

Attorney for Plaintiff: Elizabeth R. Wellborn, P.A. 350 Jim Moran Blvd. Suite 100 Deerfield Beach, FL 33442 Telephone: (954) 354-3544 Facsimile: (954) 354-3545 File # 1112-00707 April 4, 11, 2014 14-01991P

FIRST INSERTION

NOTICE OF SALE PURSUANT TO CHAPTER 45 IN THE CIRCUIT COURT OF THE SIXTH JUDICIAL CIRCUIT IN AND FOR PASCO COUNTY, FLORIDA

CIVIL ACTION CASE NO.: 51-2012-CA-008456-CAAX-WS

JPMORGAN CHASE BANK, NATIONAL ASSOCIATION, Plaintiff, vs. CARREIRO, THOMAS W. et al, Defendant(s).

NOTICE IS HEREBY GIVEN Pursuant to a Final Judgment of Foreclosure dated February 26, 2014, and entered in Case No. 51-2012-CA-008456-CAAX-WS of the Circuit Court of the Sixth Judicial Circuit in and for Pasco County, Florida in which JPMorgan Chase Bank, National Association, is the Plaintiff and Melissa A. Carreiro, Tenant # 1 also known as David Labosky, Thomas W. Carreiro, are defendants, the Pasco County Clerk of the Circuit Court will sell to the highest and best bidder for cash in/ on held online www.pasco.realforeclose.com: in Pasco County, Florida, Pasco County, Florida at 11:00AM on the 28th day of April, 2014, the following described property as set forth in said Final Judgment of Foreclosure:

LOT 251, SPRING LAKE ESTATES, UNIT THREE, ACCORDING TO THE PLAT THEREOF, RECORDED IN PLAT BOOK 9, PAGE(S) 168 OF THE PUBLIC RECORDS OF PASCO COUNTY, FLORIDA. 5432 DRIFT TIDE DR NEW PORT RICHEY FL 34652-6047 Any person claiming an interest in the surplus from the sale, if any,

other than the property owner as of the date of the Lis Pendens must file a claim within 60 days after the sale.

If you are a person with a disability who needs an accommodation in order to participate in this proceeding, you are entitled, at no cost to you, to the provision of certain assistance. Please contact:

Public Information Dept., Pasco County Government Center 7530 Little Rd. New Port Richey, FL 34654 Phone: 727.847.8110 (voice) in New Port Richey 352.521.4274, ext 8110 (voice) in Dade City Or 711 for the hearing impaired

Contact should be initiated at least seven days before the scheduled court appearance, or immediately upon receiving this notification if the time before the scheduled appearance is less than seven days.

The court does not provide transportation and cannot accommodate such requests. Persons with disabilities needing transportation to court should contact their local public transportation providers for information regarding transportation services.

Dated in Hillsborough County, Florida, this 2nd day of April, 2014

/s/ Erik Del'Etoile Erik Del'Etoile, Esq. FL Bar # 71675

Albertelli Law Attorney for Plaintiff P.O. Box 23028 Tampa, FL 33623 (813) 221-4743 (813) 221-9171 facsimile eService: servealaw@albertellilaw.com JR- 003859F01 April 4, 11, 2014 14-02038P

FIRST INSERTION

RE-NOTICE OF SALE PURSUANT TO CHAPTER 45 IN THE CIRCUIT COURT OF THE 6H JUDICIAL CIRCUIT, IN AND FOR PASCO COUNTY, FLORIDA.

CASE NO.: 51 2008-CA-008747-WS DEUTSCHE BANK NATIONAL TRUST COMPANY, AS TRUSTEE FOR GSAA HOME EQUITY TRUST 2006-15, ASSET-BACKED CERTIFICATES, SERIES 2006-15, Plaintiff, vs. PAUL A.WILLS a/k/a PAUL WILLS and Crystal Wills, Defendants,

NOTICE IS HEREBY GIVEN pursuant to a Final Judgment of Foreclosure dated December 11, 2013, and to an order resetting the foreclosure sale, dated March 20, 2014, and entered in Case No. 51 2008-CA-008747-WS of the Circuit Court of the 6th Judicial Circuit in and for Pasco County, Florida, wherein DEUTSCHE BANK NATIONAL TRUST COMPANY, AS TRUSTEE FOR GSAA HOME EQUITY TRUST 2006-15, ASSET-BACKED CERTIFICATES, SERIES 2006-15, is Plaintiff, and PAUL A.WILLS a/k/a PAUL WILLS and Crystal Wills, are Defendants, I will sell to the highest and best bidder for cash via online auction at www.pasco.realforeclose.com at 11:00 A.M. on the 24th day of April, 2014, the following described property as set forth in said Final Judgment, to wit:

LOTS 19 THROUGH 24, BLOCK C, VALENCIA TERRACE NO. 2, ACCORDING TO THE MAP OR PLAT THEREOF, AS RECORDED IN PLAT BOOK 3, PAGE 57, OF THE PUBLIC RECORDS OF PASCO COUNTY, FLORIDA.

Property Address: 6650 Florida Ave New Port Richey, Florida 34653.

and all fixtures and personal property located therein or thereon, which are included as security in Plaintiff's mortgage. Any person claiming an interest in the surplus funds from the sale, if any, other than the property owner as of the date of the lis pendens must file a claim within 60 days after the sale.

If you are a person with a disability who needs any accommodation in order to participate in this proceeding, you are entitled, at no cost to you, to the provision of certain assistance. Please contact the Public Information Dept., Pasco County Government Center, 7530 Little Rd., New Port Richey, FL 34654; (727) 847-8110 (V) in New Port Richey; (352) 521-4274, ext 8110 (V) in Dade City, at least 7 days before your scheduled court appearance, or immediately upon receiving this notification if the time before the scheduled appearance is less than 7 days; if you are hearing impaired call 711. The court does not provide transportation and cannot accommodate for this service. Persons with disabilities needing transportation to court should contact their local public transportation providers for information regarding transportation services.

Dated this 1st day of April, 2014. By: Marc Ruderman, Esq. FL Bar # 899585

Clarfield, Okon, Salomone & Pincus, P.L. 500 S. Australian Avenue, Suite 730 West Palm Beach, FL 33401 (561) 713-1400 - pleadings@cosplaw.com April 4, 11, 2014 14-02032P



## FIRST INSERTION

NOTICE OF RESCHEDULED FORECLOSURE SALE IN THE CIRCUIT COURT OF THE SIXTH JUDICIAL CIRCUIT IN AND FOR PASCO COUNTY, FLORIDA CIVIL ACTION

**CASE NO.: 51-2010-CA-004626-WS DIVISION: J2**

**CHASE HOME FINANCE LLC,**

**Plaintiff, vs. NIKITAS KAZOURIS, et al, Defendant(s).**

NOTICE IS HEREBY GIVEN pursuant to an Order Rescheduling Foreclosure Sale dated March 19, 2014 and entered in Case NO. 51-2010-CA-004626-WS of the Circuit Court of the SIXTH Judicial Circuit in and for PASCO County, Florida wherein JPMORGAN CHASE BANK, NATIONAL ASSOCIATION, SUCCESSOR BY MERGER TO CHASE HOME FINANCE LLC, is the Plaintiff and NIKITAS KAZOURIS; TENANT #1 N/K/A KIMBERLY HART are the Defendants. The Clerk will sell to the highest and best bidder for cash at WWW.PASCO.REALFORECLOSE.COM IN ACCORDANCE WITH CHAPTER 45 FLORIDA STATUTES at 11:00AM, on 04/22/2014, the following described property as set forth in said Final Judgment:

LOT 25 UNI-VILLE, SECTION TWO, ACCORDING TO THE MAP OR PLAT THEREOF, AS RECORDED IN PLAT BOOK 8, PAGE 47, OF THE PUBLIC RECORDS OF PASCO COUNTY, FLORIDA.

A/K/A 4507 BLANCHE STREET, NEW PORT RICHEY, FL 34652

Any person claiming an interest in the surplus from the sale, if any, other than the property owner as of the date of the Lis Pendens must file a claim within sixty (60) days after the sale.

\*\*See Americans with Disabilities Act

"If you are a person with a disability who needs an accommodation in order to participate in this proceeding, you are entitled, at no cost to you, to the provision of certain assistance. Please contact:

Public Information Dept., Pasco County Government Center 7530 Little Rd. New Port Richey, FL 34654 Phone: 727.847.8110 (voice) in New Port Richey 352.521.4274, ext 8110 (voice) in Dade City Or 711 for the hearing impaired

Contact should be initiated at least seven days before the scheduled court appearance, or immediately upon receiving this notification if the time before the scheduled appearance is less than seven days."

By: Shaina Druker

Florida Bar No. 0100213  
Plaintiff name has changed pursuant to order previously entered.

Ronald R Wolfe & Associates, P.L. P.O. Box 25018  
Tampa, Florida 33622-5018  
(813) 251-4766  
(813) 251-1541 Fax  
F10028852  
April 4, 11, 2014 14-02018P

## FIRST INSERTION

NOTICE OF SALE IN THE CIRCUIT CIVIL COURT OF THE SIXTH JUDICIAL CIRCUIT OF FLORIDA, IN AND FOR PASCO COUNTY CIVIL DIVISION

**Case No. 51-2013-CA-001213WS DIVISION J2**

**U.S. BANK NATIONAL ASSOCIATION Plaintiff, vs.**

**JACK D. DOYLE, BANK OF AMERICA, NA. AND UNKNOWN TENANTS/OWNERS, Defendants.**

Notice is hereby given, pursuant to Final Judgment of Foreclosure for Plaintiff entered in this cause on February 26, 2014, in the Circuit Court of Pasco County, Florida, Paula O'Neil, Clerk of the Circuit Court, will sell the property situated in Pasco County, Florida described as:

LOT 137, ALOHA GARDENS UNIT TWO, ACCORDING TO THE MAP OR PLAT THEREOF AS RECORDED IN PLAT BOOK 9, PAGE 130, OF THE PUBLIC RECORDS OF PASCO COUNTY, FLORIDA.

and commonly known as: 3826 SUN-RAY DR, HOLIDAY, FL 34691; including the building, appurtenances, and fixtures located therein, at public sale, to the highest and best bidder, for cash, www.pasco.realforeclose.com, on April 28, 2014 at 11:00 AM.

Any persons claiming an interest in

the surplus from the sale, if any, other than the property owner as of the date of the lis pendens must file a claim within 60 days after the sale.

If you are a person with a disability who needs any accommodation in order to participate in this proceeding, you are entitled, at no cost to you, to the provision of certain assistance. Please contact the Public Information Dept., Pasco County Government Center, 7530 Little Rd., New Port Richey, FL 34654; (727) 847-8110 (V) in New Port Richey; (352) 521-4274, ext 8110 (V) in Dade City, at least 7 days before your scheduled court appearance, or immediately upon receiving this notification if the time before the scheduled appearance is less than 7 days; if you are hearing impaired call 711. The court does not provide transportation and cannot accommodate for this service. Persons with disabilities needing transportation to court should contact their local public transportation providers for information regarding transportation services.

By: David J. Melvin, Esq.

Attorney for Plaintiff  
Invoice to:  
David J. Melvin  
(813) 229-0900 x1327  
Kass Shuler, P.A.  
P.O. Box 800  
Tampa, FL 33601-0800  
ForeclosureService@kasslaw.com  
327603/1224881/amml  
April 4, 11, 2014 14-02021P

## FIRST INSERTION

NOTICE OF SALE IN THE CIRCUIT COURT OF THE SIXTH JUDICIAL CIRCUIT OF THE STATE OF FLORIDA, IN AND FOR PASCO COUNTY CIVIL DIVISION

**CASE NO. 51-2012-CA-006691WS**

**BANK OF AMERICA, NATIONAL ASSOCIATION, Plaintiff, vs.**

**SHERMAN B. APPELGATE; UNKNOWN SPOUSE OF SHERMAN B. APPELGATE; BANK OF AMERICA, NATIONAL ASSOCIATION; UNKNOWN TENANT #1; UNKNOWN TENANT #2;**

**Defendant(s)**

Notice is hereby given that, pursuant to a Final Summary Judgment of Foreclosure entered on 03/06/2014 in the above-styled cause, in the Circuit Court of Pasco County, Florida, the office of Paula S. O'Neil clerk of the circuit court will sell the property situate in Pasco County, Florida, described as:

LOT 3 AND 4, BLOCK 86, REVISED PLAT OF THE TOWN OF NEW PORT RICHEY, ACCORDING TO THE PLAT THEREOF, AS RECORDED IN PLAT BOOK 4, PAGE 49, OF THE PUBLIC RECORDS OF PASCO COUNTY, FLORIDA.

at public sale, to the highest and best bidder, for cash, www.pasco.realfore-

close.com at 11:00 o'clock, A.M., on April 22, 2014

Any person claiming an interest in the surplus from the sale, if any, other than the property owner as of the date of the lis pendens, must file a claim within 60 days after the sale.

If you are a person with a disability who needs any accommodation in order to participate in this proceeding, you are entitled, at no cost to you, to the provision of certain assistance. Please contact the Public Information Dept., Pasco County Government Center, 7530 Little Rd., New Port Richey, FL 34654; (727) 847-8110 (V) for proceedings in New Port Richey; (352) 521-4274, ext. 8110 (V) for proceedings in Dade City, at least 7 days before your scheduled court appearance, or immediately upon receiving this notification if the time before the scheduled appearance is less than 7 days; if you are hearing impaired call 711.

Date: 04/01/2014

ATTORNEY FOR PLAINTIFF

By /S/ Josh D. Donnelly

Josh D. Donnelly

Florida Bar #64788

THIS INSTRUMENT PREPARED BY:

Law Offices of Daniel C. Consuegra  
9204 King Palm Drive  
Tampa, FL 33619-1328  
Phone: 813-915-8660  
Attorneys for Plaintiff  
132066

April 4, 11, 2014 14-02026P

## FIRST INSERTION

NOTICE OF SALE IN THE CIRCUIT COURT OF THE SIXTH JUDICIAL CIRCUIT OF THE STATE OF FLORIDA, IN AND FOR PASCO COUNTY CIVIL DIVISION

**CASE NO. 51-2012-CA-001511-CAAX-WS**

**EVERBANK, Plaintiff, vs.**

**MICHAEL A. BARNETT; UNKNOWN SPOUSE OF MICHAEL A. BARNETT; IF LIVING, INCLUDING ANY UNKNOWN SPOUSE OF SAID DEFENDANT(S), IF REMARRIED, AND IF DECEASED, THE RESPECTIVE UNKNOWN HEIRS, DEVISEES, GRANTEES, ASSIGNEES, CREDITORS, LIENORS, AND TRUSTEES, AND ALL OTHER PERSONS CLAIMING BY, THROUGH, UNDER OR AGAINST THE NAMED DEFENDANT(S); UNKNOWN TENANT #1; UNKNOWN TENANT #2; Defendant(s)**

Notice is hereby given that, pursuant to a Final Summary Judgment of Foreclosure entered on 03/05/2014 in the above-styled cause, in the Circuit Court of Pasco County, Florida, the office of Paula S. O'Neil clerk of the circuit court will sell the property situate in Pasco County, Florida, described as:

LOT 389, TANGLEWOOD TERRACE UNIT TWO, ACCORDING TO THE PLAT THEREOF, AS RECORDED IN PLAT BOOK 11, PAGES 84 AND 85, OF THE PUBLIC RECORDS OF PASCO COUNTY, FLORIDA.

FLORIDA.

at public sale, to the highest and best bidder, for cash, www.pasco.realforeclose.com at 11:00 o'clock, A.M., on April 22, 2014

Any person claiming an interest in the surplus from the sale, if any, other than the property owner as of the date of the lis pendens, must file a claim within 60 days after the sale.

If you are a person with a disability who needs any accommodation in order to participate in this proceeding, you are entitled, at no cost to you, to the provision of certain assistance. Please contact the Public Information Dept., Pasco County Government Center, 7530 Little Rd., New Port Richey, FL 34654; (727) 847-8110 (V) for proceedings in New Port Richey; (352) 521-4274, ext. 8110 (V) for proceedings in Dade City, at least 7 days before your scheduled court appearance, or immediately upon receiving this notification if the time before the scheduled appearance is less than 7 days; if you are hearing impaired call 711.

Date: 04/01/2014

ATTORNEY FOR PLAINTIFF

By /S/ Josh D. Donnelly

Josh D. Donnelly

Florida Bar #64788

THIS INSTRUMENT PREPARED BY:

Law Offices of Daniel C. Consuegra  
9204 King Palm Drive  
Tampa, FL 33619-1328  
Phone: 813-915-8660  
Attorneys for Plaintiff  
121649

April 4, 11, 2014 14-02027P

## FIRST INSERTION

NOTICE OF SALE IN THE CIRCUIT COURT OF THE SIXTH JUDICIAL CIRCUIT OF THE STATE OF FLORIDA, IN AND FOR PASCO COUNTY CIVIL DIVISION

**CASE NO. 51-2012-CA-000064-CAAX-WS**

**U.S. BANK NATIONAL ASSOCIATION, Plaintiff, vs.**

**DANIEL J. PIETRASZEK; UNKNOWN SPOUSE OF DANIEL J. PIETRASZEK; MARY L. PIETRASZEK; UNKNOWN SPOUSE OF MARY L. PIETRASZEK; IF LIVING, INCLUDING ANY UNKNOWN SPOUSE OF SAID DEFENDANT(S), IF REMARRIED, AND IF DECEASED, THE RESPECTIVE UNKNOWN HEIRS, DEVISEES, GRANTEES, ASSIGNEES, CREDITORS, LIENORS, AND TRUSTEES, AND ALL OTHER PERSONS CLAIMING BY, THROUGH, UNDER OR AGAINST THE NAMED DEFENDANT(S); UNKNOWN TENANT #1; UNKNOWN TENANT #2; Defendant(s)**

Notice is hereby given that, pursuant to a Final Summary Judgment of Foreclosure entered on 03/05/2014 in the above-styled cause, in the Circuit Court of Pasco County, Florida, the office of Paula S. O'Neil clerk of the circuit court will sell the property situate in Pasco County, Florida, described as:

LOT 266, HUDSON BEACH ESTATE-UNIT 3, 6TH ADD'N, ACCORDING TO THE PLAT

THEREOF AS RECORDED IN PLAT BOOK 7, PAGE 33, OF THE PUBLIC RECORDS OF PASCO COUNTY, FLORIDA.

at public sale, to the highest and best bidder, for cash, www.pasco.realforeclose.com at 11:00 o'clock, A.M., on April 22, 2014

Any person claiming an interest in the surplus from the sale, if any, other than the property owner as of the date of the lis pendens, must file a claim within 60 days after the sale.

If you are a person with a disability who needs any accommodation in order to participate in this proceeding, you are entitled, at no cost to you, to the provision of certain assistance. Please contact the Public Information Dept., Pasco County Government Center, 7530 Little Rd., New Port Richey, FL 34654; (727) 847-8110 (V) for proceedings in New Port Richey; (352) 521-4274, ext. 8110 (V) for proceedings in Dade City, at least 7 days before your scheduled court appearance, or immediately upon receiving this notification if the time before the scheduled appearance is less than 7 days; if you are hearing impaired call 711.

Date: 04/01/2014

ATTORNEY FOR PLAINTIFF

By /S/ Josh D. Donnelly

Josh D. Donnelly

Florida Bar #64788

THIS INSTRUMENT PREPARED BY:

Law Offices of Daniel C. Consuegra  
9204 King Palm Drive  
Tampa, FL 33619-1328  
Phone: 813-915-8660  
Attorneys for Plaintiff  
107682

April 4, 11, 2014 14-02029P

## FIRST INSERTION

RE-NOTICE OF SALE PURSUANT TO CHAPTER 45 IN THE CIRCUIT COURT OF THE 6TH JUDICIAL CIRCUIT IN AND FOR PASCO COUNTY, FLORIDA.

**CASE No.: 2009-CA-001396-ES**

**BANK OF AMERICA, N.A., successor by merger to BAC HOME LOANS SERVICING, L.P. F/K/A COUNTRYWIDE HOME LOANS SERVICING, L.P., Plaintiff, vs.**

**RAFAELA ROSARIO, et.al., Defendants.**

NOTICE IS HEREBY GIVEN pursuant to a Final Judgment of Foreclosure dated November 15, 2011, and to an order resetting foreclosure sale, dated March 17, 2014, and entered in Case No. 2009-CA-001396-ES of the Circuit Court of the 6th Judicial Circuit in and for Pasco County, Florida, wherein BANK OF AMERICA, N.A., successor by merger to BAC HOME LOANS SERVICING, L.P. F/K/A COUNTRYWIDE HOME LOANS SERVICING, L.P., is Plaintiff, and RAFAELA ROSARIO, et.al., are Defendants, I will sell to the highest and best bidder for cash via online auction at www.pasco.realforeclose.com at 11:00 A.M. on the 24th day of April, 2014 the following described property as set forth in said Uniform Final Judgment, to wit:

LOT 2, BLOCK 7 OF WALTERGRASS PARCEL "A" ACCORDING TO THE PLAT THEREOF AS RECORDED IN PLAT BOOK 57, PAGE(S) 73 THROUGH 86, OF THE PUBLIC RECORDS OF PASCO COUNTY, FLORIDA  
a/k/a 7046 Penta Place, Wesley

Chapel, Florida 33544 and all fixtures and personal property located therein or thereon, which are included as security in Plaintiff's mortgage.

Any person claiming an interest in the surplus funds from the sale, if any, other than the property owner as of the date of the lis pendens must file a claim within 60 days after the sale.

If you are a person with a disability who needs any accommodation in order to participate in this proceeding, you are entitled, at no cost to you, to the provision of certain assistance. Please contact the Public Information Dept., Pasco County Government Center, 7530 Little Rd., New Port Richey, FL 34654; (727) 847-8110 (V) in New Port Richey; (352) 521-4274, ext 8110 (V) in Dade City, at least 7 days before your scheduled court appearance, or immediately upon receiving this notification if the time before the scheduled appearance is less than 7 days; if you are hearing impaired call 711. The court does not provide transportation and cannot accommodate for this service. Persons with disabilities needing transportation to court should contact their local public transportation providers for information regarding transportation services.

Dated this 1st day of April, 2014.

By: Marc Ruderman, Esq.

FL Bar # 899585

Clarfield, Okon, Salomone & Pincus, P.L.

500 S. Australian Avenue, Suite 730  
West Palm Beach, FL 33401  
(561) 713-1400 -  
pleadings@coslaw.com

April 4, 11, 2014 14-02031P

## FIRST INSERTION

NOTICE OF SALE IN THE CIRCUIT COURT OF THE SIXTH JUDICIAL CIRCUIT OF THE STATE OF FLORIDA, IN AND FOR PASCO COUNTY CIVIL DIVISION

**CASE NO. 51-2012-CA-005499-CAAX-WS**

**LPP MORTGAGE LTD., Plaintiff, vs.**

**SAMMY M. ASH, JR.; UNKNOWN SPOUSE OF SAMMY M. ASH, JR.; GRAY C. ASH; UNKNOWN SPOUSE OF GRAY C. ASH; IF LIVING, INCLUDING ANY UNKNOWN SPOUSE OF SAID DEFENDANT(S), IF REMARRIED, AND IF DECEASED, THE RESPECTIVE UNKNOWN HEIRS, DEVISEES, GRANTEES, ASSIGNEES, CREDITORS, LIENORS, AND TRUSTEES, AND ALL OTHER PERSONS CLAIMING BY, THROUGH, UNDER OR AGAINST THE NAMED DEFENDANT(S); STATE OF FLORIDA; CLERK OF THE CIRCUIT COURT OF PASCO COUNTY; WHETHER DISSOLVED OR PRESENTLY EXISTING, TOGETHER WITH ANY GRANTEES, ASSIGNEES, CREDITORS, LIENORS, OR TRUSTEES OF SAID DEFENDANT(S) AND ALL OTHER PERSONS CLAIMING BY, THROUGH, UNDER, OR AGAINST DEFENDANT(S); UNKNOWN TENANT #1; UNKNOWN TENANT #2; Defendant(s)**

Notice is hereby given that, pursuant to a Final Summary Judgment of Foreclosure entered on 02/19/2014 in the above-styled cause, in the Circuit Court of Pasco County, Florida, the office of Paula S. O'Neil clerk of the circuit court will sell the property situate in Pasco County, Florida, described as:

LOT 983, ALOHA GARDENS UNIT NINE, ACCORDING TO THE PLAT THEREOF, AS RECORDED IN PLAT BOOK 11, PAGES 34 THROUGH 36, OF THE PUBLIC RECORDS OF PASCO COUNTY, FLORIDA.

at public sale, to the highest and best bidder, for cash, www.pasco.realforeclose.com at 11:00 o'clock, A.M., on April 21, 2014

will sell the property situate in Pasco County, Florida, described as:

LOT 983, ALOHA GARDENS UNIT NINE, ACCORDING TO THE PLAT THEREOF, AS RECORDED IN PLAT BOOK 11, PAGES 34 THROUGH 36, OF THE PUBLIC RECORDS OF PASCO COUNTY, FLORIDA.

at public sale, to the highest and best bidder, for cash, www.pasco.realforeclose.com at 11:00 o'clock, A.M., on April 21, 2014

Any person claiming an interest in the surplus from the sale, if any, other than the property owner as of the date of the lis pendens, must file a claim within 60 days after the sale.

If you are a person with a disability who needs any accommodation in order to participate in this proceeding, you are entitled, at no cost to you, to the provision of certain assistance. Please contact the Public Information Dept., Pasco County Government Center, 7530 Little Rd., New Port Richey, FL 34654; (727) 847-8110 (V) for proceedings in New Port Richey; (352) 521-4274, ext. 8110 (V) for proceedings in Dade City, at least 7 days before your scheduled court appearance, or immediately upon receiving this notification if the time before the scheduled appearance is less than 7 days; if you are hearing impaired call 711.

Date: 03/31/2014

ATTORNEY FOR PLAINTIFF

By /S/ Josh D. Donnelly

Josh D. Donnelly

Florida Bar #64788

THIS INSTRUMENT PREPARED BY:

Law Offices of Daniel C. Consuegra  
9204 King Palm Drive  
Tampa, FL 33619-1328  
Phone: 813-915-8660  
Attorneys for Plaintiff  
110207

April 4, 11, 2014 14-01999P

## FIRST INSERTION

NOTICE OF SALE IN THE CIRCUIT COURT OF THE SIXTH JUDICIAL CIRCUIT OF THE STATE OF FLORIDA, IN AND FOR PASCO COUNTY CIVIL DIVISION

**CASE NO. 51-2012-CA-004643-CAAX-WS**

**JPMORGAN CHASE BANK, NATIONAL ASSOCIATION, Plaintiff, vs.**

**UNKNOWN HEIRS, DEVISEES, GRANTEES, ASSIGNEES, CREDITORS, LIENORS, TRUSTEES OF LAURIE A. SKIBA, DECEASED; ANTHONY BUTTITTA, HEIR; IF LIVING, INCLUDING ANY UNKNOWN SPOUSE OF SAID DEFENDANT(S), IF REMARRIED, AND IF DECEASED, THE RESPECTIVE UNKNOWN HEIRS, DEVISEES, GRANTEES, ASSIGNEES, CREDITORS, LIENORS, AND TRUSTEES, AND ALL OTHER PERSONS CLAIMING BY, THROUGH, UNDER OR AGAINST THE NAMED DEFENDANT(S); MORTGAGE ELECTRONIC REGISTRATION SYSTEMS, INC.; WHETHER DISSOLVED OR PRESENTLY EXISTING, TOGETHER WITH ANY GRANTEES, ASSIGNEES, CREDITORS, LIENORS, OR TRUSTEES OF SAID DEFENDANT(S) AND ALL OTHER PERSONS CLAIMING BY, THROUGH, UNDER, OR AGAINST DEFENDANT(S); UNKNOWN TENANT #1; UNKNOWN TENANT #2; Defendant(s)**

Notice is hereby given that, pursuant to a Final Summary Judgment of Foreclosure entered on 03/05/2014 in the above-styled cause, in the Circuit Court of Pasco County, Florida, the office of Paula S. O'Neil clerk of the circuit court will sell the property situate in Pasco County, Florida, described as:

LOT 41, SHADOW LAKES, ACCORDING TO MAP OR PLAT THEREOF AS RECORDED IN PLAT BOOK 19, PAGES 26 AND 27 OF THE PUBLIC RECORDS OF PASCO COUNTY, FLORIDA.

at public sale, to the highest and best bidder, for cash, www.pasco.realforeclose.com at 11:00 o'clock, A.M., on April 22, 2014

Any person claiming an interest in the surplus from the sale, if any, other than the property owner as of the date of the lis pendens, must file a claim within 60 days after the sale.

If you are a person with a disability who needs any accommodation in order to participate in this proceeding, you are entitled, at no cost to you, to the provision of certain assistance. Please contact the Public Information Dept., Pasco County Government Center, 7530 Little Rd., New Port Richey, FL 34654; (727) 847-8110 (V) for proceedings in New Port Richey; (352) 521-4274, ext. 8110 (V) for proceedings in Dade City, at least 7 days before your scheduled court appearance, or immediately upon receiving this notification if the time before the scheduled appearance is less than 7 days; if you are hearing impaired call 711.

Date: 04/01/2014

ATTORNEY FOR PLAINTIFF

By /S/ Josh D. Donnelly

Josh D. Donnelly

Florida Bar #64788

THIS INSTRUMENT PREPARED BY:

Law Offices of Daniel C. Consuegra  
9204 King Palm Drive  
Tampa, FL 33619-1328  
Phone: 813-915-8660  
Attorneys for Plaintiff  
101480-T

April 4, 11, 2014 14-02030P

## FIRST INSERTION

NOTICE OF SALE IN THE CIRCUIT COURT OF THE SIXTH JUDICIAL CIRCUIT OF THE STATE OF FLORIDA, IN AND FOR PASCO COUNTY CIVIL DIVISION

**CASE NO. 51-2013-CA-002896-CAAX-WS**

**JPMC SPECIALTY MORTGAGE LLC, Plaintiff, vs.**

**TERRY P. SMITH; UNKNOWN SPOUSE OF TERRY P. SMITH; ELLEN J. SMITH; UNKNOWN SPOUSE OF ELLEN J. SMITH; IF LIVING, INCLUDING ANY UNKNOWN SPOUSE OF SAID DEFENDANT(S), IF REMARRIED, AND IF DECEASED, THE RESPECTIVE UNKNOWN HEIRS, DEVISEES, GRANTEES, ASSIGNEES, CREDITORS, LIENORS, AND TRUSTEES, AND ALL OTHER PERSONS CLAIMING BY, THROUGH, UNDER OR AGAINST THE NAMED DEFENDANT(S); UNKNOWN TENANT #1; UNKNOWN TENANT #2; Defendant(s)**

Notice is hereby given that, pursuant to a Final Summary Judgment of Foreclosure entered on 03/05/2014 in the above-styled cause, in the Circuit Court of Pasco County, Florida, the office of Paula S. O'Neil clerk of the circuit court will sell the property situate in Pasco County, Florida, described as:

LOT 1281, BEACON WOODS VILLAGE 5-C, ACCORDING TO THE PLAT THEREOF, RECORDED IN THE OFFICE OF THE CLERK OF THE CIRCUIT COURT, PASCO COUNTY, FLORIDA. PLAT BOOK 11, PAGES 130 AND 131.  
AND  
LOT 1281-A, BEACON WOODS VILLAGE 5-D, ACCORDING

TO THE PLAT THEREOF RECORDED IN THE OFFICE OF THE CLERK OF THE CIRCUIT COURT, PASCO COUNTY, FLORIDA PLAT BOOK 14, PAGES 16 AND 17.  
PARCEL ID #: 02-25-16-051L-00001-2810

FIRST INSERTION

NOTICE OF FORECLOSURE SALE PURSUANT TO CHAPTER 45 IN THE CIRCUIT COURT OF THE SIXTH JUDICIAL CIRCUIT IN AND FOR PASCO COUNTY, FLORIDA CASE NO. 51-2012-CA-6587-ES-J1 DEUTSCHE BANK NATIONAL TRUST COMPANY, AS TRUSTEE FOR GSAMP TRUST 2007-HSBC1 MORTGAGE PASS-THROUGH CERTIFICATES, SERIES 2007-HSBC1 Plaintiff(s), vs. KENYA LEWIS A/K/A KENYA AYESHA LEWIS A/K/A KENYA A. LEWIS; et al., Defendant(s). NOTICE IS HEREBY GIVEN THAT Sale will be made pursuant to an Order or Final Summary Judgment. Final Judgment was awarded on January 22, 2014 in Civil Case No.: 51-2012-CA-6587-ES-J1, of the Circuit Court of the SIXTH Judicial Circuit in and for PASCO County, Florida, wherein, DEUTSCHE BANK NATIONAL TRUST COMPANY, AS TRUSTEE FOR GSAMP TRUST 2007-HSBC1 MORTGAGE PASS-THROUGH CERTIFICATES, SERIES 2007-HSBC1 is the Plaintiff, and, KENYA LEWIS A/K/A KENYA AYESHA LEWIS A/K/A KENYA A. LEWIS; GTE FEDERAL CREDIT UNION; AND UNKNOWN TENANT(S) IN POSSES-

SION are Defendants. The clerk of the court, Paula S. O'Neil, Ph.D., will sell to the highest bidder for cash online at www.pasco.realforeclose.com at 11:00 AM on April 17, 2014, the following described real property as set forth in said Final summary Judgment, to wit: LOT 56, BLOCK 2, MEADOW POINTE, PARCEL 8, UNIT 4, ACCORDING TO MAP OR PLAT THREOF AS RECORDED IN PLAT BOOK 32, PAGES 135-139, OF THE PUBLIC RECORDS OF PASCO COUNTY, FLORIDA. PROPERTY ADDRESS: 1641 FIREWHEEL DRIVE, WESLEY CHAPEL, FLORIDA 33543 ANY PERSON CLAIMING AN INTEREST IN THE SURPLUS FROM THE SALE, IF ANY, OTHER THAN THE PROPERTY OWNER AS OF THE DATE OF THE LIS PENDENS MUST FILE A CLAIM WITHIN 60 DAYS AFTER THE SALE. IMPORTANT If you are a person with a disability who needs an accommodation in order to participate in this proceeding, you are entitled, at no cost to you, to the provision of certain assistance. Please contact: Public Information Dept.,

Pasco County Government Center, 7530 Little Rd., New Port Richey, FL 34654; Phone: 727.847.8110 (voice) in New Port Richey, 352.521.4274, ext 8110 (voice) in Dade City, Or 711 for the hearing impaired. Contact should be initiated at least seven days before the scheduled court appearance, or immediately upon receiving this notification if the time before the scheduled appearance is less than seven days. The court does not provide transportation and cannot accommodate such requests. Persons with disabilities needing transportation to court should contact their local public transportation providers for information regarding transportation services. Dated this 1 day of April, 2014. BY: Nalini Singh FBN: 43700 Primary E-Mail: ServiceMail@aclawllp.com Secondary E-Mail: NSingh@aclawllp.com Aldridge | Connors, LLP Attorney for Plaintiff(s) 1615 South Congress Avenue Suite 307 Delray Beach, FL 33445 Phone: 561.392.6391 Fax: 561.392.6965 1090-1014 April 4, 11, 2014 14-02033P

NOTICE OF FORECLOSURE SALE IN THE CIRCUIT COURT OF THE SIXTH JUDICIAL CIRCUIT IN AND FOR PASCO COUNTY, FLORIDA CIVIL DIVISION Case No.: 51-2012-CA-003956WS Division: J2 BANK OF AMERICA, N.A. Plaintiff, v. WALTER PIETSCHMANN; ET AL. Defendants, NOTICE IS HEREBY GIVEN pursuant to a Final Judgment dated March 5, 2014, entered in Civil Case No.: 51-2012-CA-003956WS, DIVISION: J2, of the Circuit Court of the SIXTH Judicial Circuit in and for Pasco County, Florida, wherein GREEN TREE SERVICING, LLC is Plaintiff, and WALTER PIETSCHMANN; UNKNOWN SPOUSE OF WALTER PIETSCHMANN; TIMBER OAKS COMMUNITY SERVICES ASSOCIATION, INC.; LINKSIDE VILLAGE CONDOMINIUM II ASSOCIATION, INC.; UNKNOWN TENANT #1; UNKNOWN TENANT #2; ALL OTHER UNKNOWN PARTIES CLAIMING INTERESTS BY, THROUGH, UNDER, AND AGAINST A NAMED DEFENDANT(S) WHO ARE NOT KNOWN TO BE DEAD OR ALIVE, WHETHER SAME UNKNOWN

PARTIES MAY CLAIM AN INTEREST AS SPOUSES, HEIRS, DEVISEES, GRANTEES, OR OTHER CLAIMANTS, are Defendant(s). PAULA S. O'NEIL, Clerk of the Court, will sell to the highest bidder for cash at 11:00 a.m. online at www.pasco.realforeclose.com on the 23rd day of April, 2014 the following described real property as set forth in said Final Summary Judgment, to wit: UNIT NO. 81, OF LINKSIDE VILLAGE CONDOMINIUM II, PHASE I, A CONDOMINIUM, ACCORDING TO THE DECLARATION OF CONDOMINIUM RECORDED IN O.R. BOOK 3937, PAGE 1171, AND ALL EXHIBITS AND AMENDMENTS THEREOF, AND RECORDED IN CONDOMINIUM PLAT BOOK 23, PAGE 12, PUBLIC RECORDS OF PASCO COUNTY, FLORIDA. If you are a person claiming a right to funds remaining after the sale, you must file a claim with the clerk no later than 60 days after the sale. If you fail to file a claim you will not be entitled to any remaining funds. After 60 days, only the owner of record as of the date of the lis pendens may claim the surplus. IN ACCORDANCE WITH THE

AMERICANS WITH DISABILITIES ACT, If you are a person with a disability who needs any accommodation in order to participate in this proceeding, you are entitled at no cost to you, to the provision of certain assistance. Please contact: Public Information Dept., Pasco County Government Center, 7530 Little Rd., New Port Richey, FL 34654; (727) 847-8110 (voice) for proceedings in New Port Richey; (352) 521-4274, ext 8110 (voice) for proceedings in Dade City at least 7 days before your scheduled court appearance, or immediately upon receiving this notification if the time before the scheduled appearance is less than 7 days; if you are hearing or voice impaired, call 711. Dated this 28 day of March, 2014. /s/ Joshua Sabet By: Joshua Sabet, Esquire Fla. Bar No.: 85356 Primary Email: JSabet@ErwLaw.com Secondary Email: docservice@erwlaw.com Attorney for Plaintiff: Elizabeth R. Wellborn, P.A. 350 Jim Moran Blvd. Suite 100 Deerfield Beach, FL 33442 Telephone: (954) 354-3544 Facsimile: (954) 354-3545 FILE # 8377ST-38452 April 4, 11, 2014 14-02034P

FIRST INSERTION

NOTICE OF RESCHEDULED SALE IN THE CIRCUIT COURT OF THE SIXTH JUDICIAL CIRCUIT IN AND FOR PASCO COUNTY, FLORIDA CIVIL ACTION CASE NO.: 51-2012-CA-006775-CAAX-ES PHH MORTGAGE CORPORATION, Plaintiff, vs. SYMMERS, DIANE L et al, Defendant(s). NOTICE IS HEREBY GIVEN Pursuant to an Order Rescheduling Foreclosure Sale dated on or about March 12, 2014, and entered in Case No. 51-2012-CA-006775-CAAX-ES of the Circuit Court of the Sixth Judicial Circuit in and for Pasco County, Florida in which PHH Mortgage Corporation, is the Plaintiff and Diane L Symmers, Nicholas A Buis also known as Nicholas Buis, RBS Citizens, N.A., The Unknown Spouse of Nicholas A Buis also known as Nicholas Buis also known as Priscilla Buis, are defendants, the Pasco County Clerk of the Circuit Court will sell to the highest and best bidder for cash held online www.pasco.realforeclose.com: in Pasco County, Florida at 11:00AM on the 28th day of April, 2014, the following described property as set forth in said Final Judgment of Foreclosure: LOT 13, DESCRIBED AS COMMENCING AT THE SOUTHEAST CORNER OF THE WEST 1/4 OF THE NORTHEAST 1/4 OF THE SOUTHEAST 1/4 OF SECTION 11, TOWNSHIP 26 SOUTH, RANGE 18 EAST, PASCO COUNTY, FLORIDA; RUN THENCE NORTH 00 DEGREES 00

MINUTES 30 SECONDS EAST, ALONG THE EAST BOUNDARY OF THE SAID WEST 1/4 OF THE NORTHEAST 1/4 OF THE SOUTHEAST 1/4 OF SECTION 11, A DISTANCE OF 1281 FEET TO THE POINT OF BEGINNING, THENCE WEST ALONG A LINE PARALLEL WITH THE SOUTH BOUNDARY OF THE SAID NORTHEAST 1/4 OF SECTION 11, A DISTANCE OF 35 FEET; THENCE NORTH 12 DEGREES 30 MINUTES 00 SECONDS WEST, A DISTANCE OF 320 FEET, MORE OR LESS, TO THE WATERS OF LAKE THOMAS; THENCE NORTHEASTERLY ALONG THE WATERS OF LAKE THOMAS, A DISTANCE OF 118 FEET MORE OR LESS TO THE EAST BOUNDARY OF THE WEST 1/4 OF THE SOUTHEAST 1/4 OF SECTION 11, A DISTANCE OF 35 FEET; THENCE SOUTH 00 DEGREES 00 MINUTES 30 SECONDS WEST, ALONG THE SAID EAST BOUNDARY OF THE WEST 1/4 OF THE SOUTHEAST 1/4 OF SECTION 11 AND PROJECTION THEREOF, A DISTANCE OF 347 FEET MORE OR LESS TO THE POINT OF BEGINNING. RESERVING THE EAST 25 FEET THEREOF FOR AN ACCESS EASEMENT FOR INGRESS AND EGRESS. 5453 SHELL RD, LAND O LAKES, FL 34638-3341 Any person claiming an interest in the surplus from the sale, if any, other than

the property owner as of the date of the Lis Pendens must file a claim within 60 days after the sale. If you are a person with a disability who needs an accommodation in order to participate in this proceeding, you are entitled, at no cost to you, to the provision of certain assistance. Please contact: Public Information Dept., Pasco County Government Center 7530 Little Rd. New Port Richey, FL 34654 Phone: 727.847.8110 (voice) in New Port Richey 352.521.4274, ext 8110 (voice) in Dade City Or 711 for the hearing impaired Contact should be initiated at least seven days before the scheduled court appearance, or immediately upon receiving this notification if the time before the scheduled appearance is less than seven days. The court does not provide transportation and cannot accommodate such requests. Persons with disabilities needing transportation to court should contact their local public transportation providers for information regarding transportation services. Dated in Hillsborough County, Florida, this 1st day of April, 2014 /s/ Erik Del'Etoile Erik Del'Etoile, Esq. FL Bar # 71675 Albertelli Law Attorney for Plaintiff P.O. Box 23028 Tampa, FL 33623 (813) 221-4743 (813) 221-9171 facsimile eService: servealaw@albertellilaw.com BM - 011744F01 April 4, 11, 2014 14-02037P

NOTICE OF SALE PURSUANT TO CHAPTER 45 IN THE CIRCUIT COURT OF THE SIXTH JUDICIAL CIRCUIT IN AND FOR PASCO COUNTY, FLORIDA CIVIL ACTION CASE NO.: 51-2009-CA-004353-CAAX-ES GMAC MORTGAGE, LLC, Plaintiff, vs. STANTON, PHILLIP et al, Defendant(s). NOTICE IS HEREBY GIVEN Pursuant to a Final Judgment of Foreclosure dated March 4, 2014, and entered in Case No. 51-2009-CA-004353-CAAX-ES of the Circuit Court of the Sixth Judicial Circuit in and for Pasco County, Florida in which GMAC Mortgage, LLC, is the Plaintiff and Community Bank of Manatee, Jane Doe N/K/A Heather Vivier, John Doe N/K/A Charles Stanton, Phillip M. Stanton, Wendy L. Stanton, are defendants, the Pasco County Clerk of the Circuit Court will sell to the highest and best bidder for cash in/on held online www.pasco.realforeclose.com: in Pasco County, Florida, Pasco County, Florida at 11:00AM on the 21st day of April, 2014, the following described property as set forth in said Final Judgment of Foreclosure: THAT PORTION OF THE NORTHWEST 1/4 OF SECTION 5, TOWNSHIP 25, RANGE 18 EAST, BEING FURTHER DESCRIBED AS FOLLOWS: COMMENCING AT THE SOUTHEAST CORNER OF THE NORTHWEST 1/4 OF SECTION 5, TOWNSHIP 25 SOUTH, RANGE 18 EAST. RUN SOUTH 0 DEGREES 50 MINUTES 40

SECONDS WEST, 25.36 FEET ALONG THE NORTH/SOUTH CENTERLINE OF SAID SECTION 5, THENCE NORTH 88 DEGREES 44 MINUTES 20 SECONDS WEST 991.70 FEET, THENCE NORTH 0 DEGREES 46 MINUTES 50 SECONDS EAST, 575.0 FEET FOR A POINT OF BEGINNING. THENCE CONTINUE NORTH 88 DEGREES 44 MINUTES 20 SECONDS WEST, 330.12 FEET THE WEST LINE OF THE SOUTHEAST 1/4 OF THE NORTHWEST 1/4 OF SAID SECTION 5, THENCE NORTH 0 DEGREES 55 MINUTES 00 SECONDS EAST, 200.0 FEET ALONG THE SAID WEST LINE OF THE SOUTHEAST 1/4 OF THE NORTHWEST 1/4 OF SECTION 5, THENCE SOUTH 88 DEGREES 44 MINUTES 20 SECONDS EAST, 330.58 FEET, THENCE SOUTH 0 DEGREES 46 MINUTES 50 SECONDS WEST, 200.0 FEET TO THE POINT OF BEGINNING, SUBJECT, HOWEVER, TO AN EASEMENT OVER AND ACROSS THE EAST 25 FEET THEREOF AND NORTH 25 FEET OF THE EAST 130.58 FEET THEREOF FOR UTILITIES AND INGRESS AND EGRESS. BEING LOT 229. TOGETHER WITH A 1997 DOUBLEWIDE MOBILE HOME, VIN #S: FLFL70A24772HL21 AND FLFL70B24772HL21. 12635 PRICE LN, SPRING HILL, FL 34610 Any person claiming an interest in the surplus from the sale, if any, other than

the property owner as of the date of the Lis Pendens must file a claim within 60 days after the sale. If you are a person with a disability who needs an accommodation in order to participate in this proceeding, you are entitled, at no cost to you, to the provision of certain assistance. Please contact: Public Information Dept., Pasco County Government Center 7530 Little Rd. New Port Richey, FL 34654 Phone: 727.847.8110 (voice) in New Port Richey 352.521.4274, ext 8110 (voice) in Dade City Or 711 for the hearing impaired Contact should be initiated at least seven days before the scheduled court appearance, or immediately upon receiving this notification if the time before the scheduled appearance is less than seven days. The court does not provide transportation and cannot accommodate such requests. Persons with disabilities needing transportation to court should contact their local public transportation providers for information regarding transportation services. Dated in Hillsborough County, Florida, this 28th day of March, 2014 /s/ Erik Del'Etoile Erik Del'Etoile, Esq. FL Bar # 71675 Albertelli Law Attorney for Plaintiff P.O. Box 23028 Tampa, FL 33623 (813) 221-4743 (813) 221-9171 facsimile eService: servealaw@albertellilaw.com BM - 10-61479 April 4, 11, 2014 14-01982P

FIRST INSERTION

NOTICE OF SALE PURSUANT TO CHAPTER 45 IN THE CIRCUIT COURT OF THE SIXTH JUDICIAL CIRCUIT IN AND FOR PASCO COUNTY, FLORIDA CIVIL ACTION CASE NO.: 51-2013-CA-004222-CAAX-WS JPMORGAN CHASE BANK, NATIONAL ASSOCIATION, Plaintiff, vs. KNIGHT, ANTHONY et al, Defendant(s). NOTICE IS HEREBY GIVEN Pursuant to a Final Judgment of Foreclosure dated March 5, 2014, and entered in Case No. 51-2013-CA-004222-CAAX-WS of the Circuit Court of the Sixth Judicial Circuit in and for Pasco County, Florida in which JPMorgan Chase Bank, National Association, is the Plaintiff and Anthony G. Knight, are defendants, the Pasco County Clerk of the Circuit Court will sell to the highest and best bidder for cash in/on held online www.pasco.realforeclose.com: in Pasco County, Florida, Pasco County, Florida at 11:00AM on the 23rd day of April, 2014, the following described property as set forth in said Final Judgment of Foreclosure: ALL THAT CERTAIN PARCEL OF LAND SITUATE IN THE COUNTY OF PASCO, STATE OF FLORIDA, BEING KNOWN AND DESIGNATED AS FOLLOWS: TRACT 6-B: FROM THE SOUTHWEST CORNER OF SECTION 20, TOWNSHIP 25 SOUTH, RANGE 19 EAST, PASCO COUNTY, FLORIDA (ALSO BEING THE NORTHWEST CORNER OF SECTION 29); RUN THENCE SOUTH

4 DEGREES 06 MINUTES 19 SECONDS WEST, 722.85 FEET ALONG THE WEST BOUNDARY OF THE NORTHWEST 1/4 OF SAID SECTION 29 THENCE SOUTH 85 DEGREES 36 MINUTES 48 SECONDS EAST, 263.43 FEET TO A CONCRETE MONUMENT; THENCE NORTH 25 DEGREES 07 MINUTES 00 SECONDS EAST, 392.21 FEET TO A CONCRETE MONUMENT; THENCE CONTINUE NORTH 25 DEGREES 07 MINUTES 00 SECONDS EAST, 451.50 FEET; THENCE SOUTH 86 DEGREES 10 MINUTES 10 SECONDS EAST, 405.57 FEET; THENCE SOUTH 3 DEGREES 49 MINUTES 50 SECONDS WEST, 25.00 FEET TO THE POINT OF BEGINNING; THENCE SOUTH 86 DEGREES 10 MINUTES 10 SECONDS EAST ALONG THE SOUTH BOUNDARY OF AN UNOBSTRUCTED EASEMENT FOR ROAD AND UTILITY PURPOSES FOR A DISTANCE OF 15.00 FEET; THENCE SOUTH 3 DEGREES 49 MINUTES 50 SECONDS WEST, 251.38 FEET; THENCE SOUTH 85 DEGREES 36 MINUTES 48 SECONDS EAST, 260.01 FEET; THENCE SOUTH 3 DEGREES 49 MINUTES 50 SECONDS WEST, 150.00 FEET; THENCE NORTH 85 DEGREES 36 MINUTES 48 SECONDS WEST, 275.01 FEET; THENCE NORTH 3 DEGREES 49 MINUTES 50 SECONDS EAST, 401.23 FEET TO THE POINT OF BEGINNING. 23145 BELINDA DR, LAND O LAKES, FL 34639-2727

Any person claiming an interest in the surplus from the sale, if any, other than the property owner as of the date of the Lis Pendens must file a claim within 60 days after the sale. If you are a person with a disability who needs an accommodation in order to participate in this proceeding, you are entitled, at no cost to you, to the provision of certain assistance. Please contact: Public Information Dept., Pasco County Government Center 7530 Little Rd. New Port Richey, FL 34654 Phone: 727.847.8110 (voice) in New Port Richey 352.521.4274, ext 8110 (voice) in Dade City Or 711 for the hearing impaired Contact should be initiated at least seven days before the scheduled court appearance, or immediately upon receiving this notification if the time before the scheduled appearance is less than seven days. The court does not provide transportation and cannot accommodate such requests. Persons with disabilities needing transportation to court should contact their local public transportation providers for information regarding transportation services. Dated in Hillsborough County, Florida, this 31st day of March, 2014 /s/ Erik Del'Etoile Erik Del'Etoile, Esq. FL Bar # 71675 Albertelli Law Attorney for Plaintiff P.O. Box 23028 Tampa, FL 33623 (813) 221-4743 (813) 221-9171 facsimile eService: servealaw@albertellilaw.com JR- 13-112170 April 4, 11, 2014 14-02007P

NOTICE OF SALE IN THE CIRCUIT COURT OF THE 6th JUDICIAL CIRCUIT IN AND FOR PASCO COUNTY, FLORIDA, CIVIL ACTION CASE NO.: 2010-CA-006953-ES Bank of America, N.A., Successor by Merger to BAC Home Loans Servicing LP, FKA Countrywide Home Loans Servicing, LP, Plaintiff vs. PHILIP STEUBER, et al. Defendant(s) Notice is hereby given that, pursuant to an Order Rescheduling Foreclosure Sale dated March 12, 2014, entered in Civil Case Number 2010-CA-006953-ES, in the Circuit Court for Pasco County, Florida, wherein Bank of America, N.A., Successor by Merger to BAC Home Loans Servicing LP, FKA Countrywide Home Loans Servicing, LP is the Plaintiff, and PHILIP STEUBER, et al., are the Defendants, Pasco County Clerk of Court - East Side will sell the property situated in Pasco County, Florida, described as: LOT 31, BLOCK 22, OAKSTEAD PARCEL 5, ACCORDING TO THE MAP OR PLAT THEREOF AS RECORDED IN PLAT BOOK 47, PAGES 46-60, PUBLIC RECORDS OF PASCO COUNTY, FLORIDA. at public sale, to the highest and best bidder, for cash, at www.pasco.realforeclose.com at 11:00 AM, on the 17th day of April, 2014. Any person claiming an interest in the surplus from the sale, if any, other than the property owner as of the date of the lis pendens must file a claim within 60 days after the sale. If you are a person with a disability who needs any accommodation in order to participate in this proceeding, you are entitled, at no cost to you to the provision of certain assistance. Within two (2) working days of your receipt of this (describe notice/order)

please contact the Public Information Dept., Pasco County Government Center, 7530 Little Rd., New Port Richey, FL 34654; (727) 847-8110 (V) in New Port Richey; (352) 521-4274, ext. 8110 (V) in Dade City; via 1-800-955-8771 if you are hearing impaired. The court does not provide transportation and cannot accommodate for this service. Persons with disabilities needing transportation to court should contact their local public transportation providers for information regarding disabled transportation services. Si ou se yon moun ki gen yon andikap ki bezwen aranjanman nenpòt nan lòd you patisipe nan sa a pwosè dapèl, ou gen dwa, san sa pa kouste ou nan dispozisyon pou asistans a sèten. Nan de (2) k ap travay jou apre you resevwa ou nan sa a (dekri avi / lòd) tanpri kontakte Enfòmasyon Piblik la Dept, Gouvènman Konte Pasco Center, 7530 Little Rd, New Port Richey, FL 34654; (727) 847-8110 (V) nan New Port Richey; (352) 521-4274, ext. 8110 (V) nan Dade City; via 1-800-955-8771 si ou genyen pwoblèm pou tande. Tribinal la pa bay transpò epi you pa kapab akomode pou sèvis sa a. Moun ki andikape ki bezwen transpò nan tribinal la ta dwe kontakte founisè lokal transpò you piblik pou enfòmasyon konsènan sèvis transpò ki andikape. Si vous êtes une personne handicapée qui a besoin d'une adaptation pour pouvoir participer à cette instance, vous avez le droit, sans frais pour vous à la fourniture d'une assistance certain. Dans les deux (2) jours ouvrables suivant la réception de la présente (décrire avis / ordre) s'il vous plaît contacter le Département de l'information publique, Pasco County Government Center, 7530 Rd Little, New Port Richey, FL 34654. (727) 847-8110 (V) à New Port Richey,

(352) 521-4274, ext. 8110 (V) à Dade City, via 1-800-955-8771 si vous êtes sourd ou malentendant. Le tribunal n'a pas assurer le transport et ne peut pas s'accommoder de ce service. Les personnes handicapées ont besoin transport vers le tribunal doit communiquer avec leurs fournisseurs locaux de transport en commun des informations concernant les services de transport à mobilité réduite. Si usted es una persona con alguna discapacidad que necesita cualquier acomodación para poder participar en este procedimiento, usted tiene derecho, sin costo alguno para usted a la prestación de asistencia determinada. Dentro de los dos (2) días hábiles siguientes a la recepción de esta (describir aviso / order) por favor póngase en contacto con el Departamento de Información Pública, Pasco County Government Center, 7530 Rd Little, New Port Richey, FL 34654. (727) 847-8110 (V) en New Port Richey, (352) 521-4274, ext. 8110 (V) en Dade City, a través 1-800-955-8771 si tiene problemas de audición. El tribunal no proporciona el transporte y no se puede acomodar para este servicio. Las personas con discapacidad que necesitan transporte a los tribunales deberán contactar a sus proveedores locales de transporte público para obtener información sobre los servicios de transporte con discapacidad. Dated: March 30, 2014 By: /s/ Josh Arthur Josh Arthur, Esquire (FBN 95506) FLORIDA FORECLOSURE ATTORNEYS, PLLC 4855 Technology Way, Suite 500 Boca Raton, FL 33431 (727) 446-4826 emailservice@flapllc.com Our File No: CA13-06501-T /CQ April 4, 11, 2014 14-01984P

FIRST INSERTION

NOTICE OF FORECLOSURE SALE IN THE CIRCUIT COURT OF THE SIXTH JUDICIAL CIRCUIT, IN AND FOR PASCO COUNTY, FLORIDA. CASE NO. 2009CA003416CAAXES THE BANK OF NEW YORK MELLON FKA THE BANK OF NEW YORK, AS TRUSTEE FOR THE CERTIFICATE HOLDERS CWALT, INC., ALTERNATIVE LOAN TRUST 2006-40T1, MORTGAGE PASS-THROUGH CERTIFICATES, SERIES 2006-40T1, PLAINTIFF, VS. PETER FERRENTINO, ET AL. DEFENDANT(S).

NOTICE IS HEREBY GIVEN pursuant to the Final Judgment of Foreclosure dated June 25, 2013 in the above action, the Pasco County Clerk of Court will sell to the highest bidder for cash at Pasco, Florida, on April 24, 2014, at 11:00 AM, at www.pasco.realforeclose.com for the following described prop-

erty: Lot 47, PASCO TRAILS, UNIT ONE, as recorded in Plat Book 14, Page 40 through 43, Public Records of Pasco County, Florida.

Any person claiming an interest in the surplus from the sale, if any, other than the property owner as of the date of the lis pendens must file a claim within sixty (60) days after the sale. The Court, in its discretion, may enlarge the time of the sale. Notice of the changed time of sale shall be published as provided herein.

If you are a person with a disability who needs any accommodation in order to participate in this proceeding, you are entitled, at no cost to you, to the provision of certain assistance. Please contact the Public Information Department at 727-847-8110 in New Port Richey or 352-521-4274, extension 8110 in Dade City or at Pasco County Government Center, 7530 Little Road, New Port

Richey, FL 34654 at least 7 days before your scheduled court appearance, or immediately upon receiving this notification if the time before the scheduled appearance is less than 7 days; if you are hearing or voice impaired, call 711.

The court does not provide transportation and cannot accommodate such requests. Persons with disabilities needing transportation to court should contact their local public transportation providers for information regarding transportation services.

By: J.C. Carrillo, Esq. FBN 753734

Gladstone Law Group, P.A. Attorney for Plaintiff 1499 W. Palmetto Park Road, Suite 300 Boca Raton, FL 33486 Telephone #: 561-338-4101 Fax #: 561-338-4077 Email: eservice@glaw.net Our Case #: 09-000841-F April 4, 11, 2014 14-02040P

FIRST INSERTION

NOTICE OF FORECLOSURE SALE IN THE CIRCUIT COURT OF THE 6TH JUDICIAL CIRCUIT IN AND FOR PASCO COUNTY, FLORIDA

CASE NO: 10CA002979 BAC HOME LOANS SERVICING, LP F/K/A COUNTRYWIDE HOME LOANS SERVICING, LP. Plaintiff, vs.

TIMOTHY S WYMAN AND DIANE S WYMAN, et al. Defendants.

NOTICE IS HEREBY GIVEN pursuant to a Final Judgment of Foreclosure dated March 14, 2014 entered in Civil Case No.: 10CA002979 of the 6th Judicial Circuit in Dade City, Pasco County, Florida, Paula S. O'Neil, the Clerk of the Court, will sell to the highest and best bidder for cash online at www.pasco.realforeclose.com at 11:00 A.M. EST on the 29 day of April 2014 the following described property as set forth in said Final Judgment, to-wit:

LOT 359 OF SOUTHERN OAKS UNIT FOUR, ACCORDING TO THE PLAT THEREOF AS RECORDED IN PLAT BOOK 37, PAGES 43 THROUGH 47, OF THE PUBLIC RECORDS OF PASCO COUNTY, FLORIDA.

Any person claiming an interest in the surplus from the sale, if any, other than the property owner as of the date of the lis pendens, must file a claim with the clerk of court within 60 days after the sale.

IF YOU ARE A PERSON WITH A DISABILITY WHO NEEDS AN ACCOMMODATION IN ORDER TO PARTICIPATE IN THIS PROCEEDING, YOU ARE ENTITLED, AT NO COST TO YOU, TO THE PROVISION OF CERTAIN ASSISTANCE. PLEASE CONTACT: PUBLIC INFORMATION DEPT., PASCO COUNTY GOVERNMENT CENTER, 7530 LITTLE RD., NEW PORT RICHEY, FL 34654 - PHONE:

727.847.8110 (VOICE) IN NEW PORT RICHEY, 352.521.4274, EXT 8110 (VOICE) IN DADE CITY OR 711 FOR THE HEARING IMPAIRED CONTACT SHOULD BE INITIATED AT LEAST SEVEN DAYS BEFORE THE SCHEDULED COURT APPEARANCE, OR IMMEDIATELY UPON RECEIVING THIS NOTIFICATION IF THE TIME BEFORE THE SCHEDULED APPEARANCE IS LESS THAN SEVEN DAYS.

Dated this 27 day of March, 2014. s/ Maria Fernandez-Gomez By: Maria Fernandez-Gomez, Esq. Fla. Bar No. 998494

TRIPP SCOTT, P.A. Attorneys for Plaintiff 110 S.E. Sixth St., 15th Floor Fort Lauderdale, FL 33301 Telephone (954) 765-2999 Facsimile (954) 761-8475 Email: mfg@trippscott.com 13-017620 April 4, 11, 2014 14-01966P

FIRST INSERTION

NOTICE OF RESCHEDULED FORECLOSURE SALE IN THE CIRCUIT COURT OF THE SIXTH JUDICIAL CIRCUIT IN AND FOR PASCO COUNTY, FLORIDA CIVIL ACTION

CASE NO.: 51-2012-CA-000182WS DIVISION: J2

WELLS FARGO BANK, NA, Plaintiff, vs. JEFFREY R. MEYER, et al, Defendant(s).

NOTICE IS HEREBY GIVEN pursuant to an Order Rescheduling Foreclosure Sale dated March 19, 2014 and entered in Case NO. 51-2012-CA-000182WS of the Circuit Court of the SIXTH Judicial Circuit in and for PASCO County, Florida wherein WELLS FARGO BANK, NA, is the Plaintiff and JEFFREY R MEYER; JEFFREY R. MEYER, AS TRUSTEE OF THE J & K LAND TRUST DATED OCTOBER 11, 2004; KAREN A. MALLUCK, AS TRUSTEE OF THE J & K LAND TRUST DATED OCTOBER 11, 2004; THE UNKNOWN BENEFICIARIES OF THE J & K LAND TRUST DATED OCTOBER 11, 2004; ANY AND ALL UNKNOWN PARTIES CLAIMING BY, THROUGH, UNDER, AND AGAINST THE HEREIN NAMED

INDIVIDUAL DEFENDANT(S) WHO ARE NOT KNOWN TO BE DEAD OR ALIVE, WHETHER SAID UNKNOWN PARTIES MAY CLAIM AN INTEREST AS SPOUSES, HEIRS, DEVISEES, GRANTEEES, OR OTHER CLAIMANTS; TENANT #1 N/K/A DON LEACH; TENANT #2 N/K/A MARY LEACH are the Defendants, The Clerk will sell to the highest and best bidder for cash at WWW.PASCO.REALFORECLOSE.COM IN ACCORDANCE WITH CHAPTER 45 FLORIDA STATUTES at 11:00AM, on 04/23/2014, the following described property as set forth in said Final Judgment:

LOT 1034, AND THE EAST-ERLY 1/2 OF LOT 1035, PALM TERRACE GARDENS, UNIT FIVE, ACCORDING TO THE PLAT THEREOF AS RECORDED IN PLAT BOOK 15, PAGES 37 AND 38, OF THE PUBLIC RECORDS OF PASCO COUNTY, FLORIDA A/K/A 7534 IRONBARK DRIVE, PORT RICHEY, FL 34668

Any person claiming an interest in the surplus from the sale, if any, other than the property owner as of the date of the

Lis Pendens must file a claim within sixty (60) days after the sale.

\*\*See Americans with Disabilities Act

"If you are a person with a disability who needs an accommodation in order to participate in this proceeding, you are entitled, at no cost to you, to the provision of certain assistance. Please contact:

Public Information Dept., Pasco County Government Center 7530 Little Rd. New Port Richey, FL 34654 Phone: 727.847.8110 (voice) in New Port Richey 352.521.4274, ext 8110 (voice) in Dade City Or 711 for the hearing impaired

Contact should be initiated at least seven days before the scheduled court appearance, or immediately upon receiving this notification if the time before the scheduled appearance is less than seven days."

By: Amy Recla Florida Bar No. 102811

Ronald R Wolfe & Associates, P.L. P.O. Box 25018 Tampa, Florida 33622-5018 (813) 251-4766 (813) 251-1541 Fax F11018752 April 4, 11, 2014 14-02017P

FIRST INSERTION

NOTICE OF FORECLOSURE SALE IN THE CIRCUIT COURT OF THE SIXTH JUDICIAL CIRCUIT OF FLORIDA IN AND FOR PASCO COUNTY GENERAL JURISDICTION DIVISION CASE NO.

51-2009-CA-011873-XXXX-WS BANK OF AMERICA, N.A., AS SUCCESSOR BY MERGER TO BAC HOME LOANS SERVICING, L.P., Plaintiff, vs.

CLINTON B. FORBES, et al., Defendants.

NOTICE IS HEREBY GIVEN pursuant to a Summary Final Judgment of Foreclosure entered December 11, 2013 in Civil Case No. 51-2009-CA-011873-XXXX-WS of the Circuit Court of the SIXTH Judicial Circuit in and for Pasco County, Dade City, Florida, wherein BANK OF AMERICA, N.A., AS SUCCESSOR BY MERGER TO BAC HOME LOANS SERVICING, L.P. is Plaintiff and CLINTON B. FORBES, UNKNOWN SPOUSE OF CLINTON B. FORBES N/K/A INGA SMITH, MORTGAGE ELECTRONIC REGISTRATION

SYSTEMS, INC., AS NOMINEE FOR COUNTRYWIDE BANK, FSB, JANE DOE N/K/A HEATHER BURKHART, JOHN DOE N/K/A JONATHAN BURKHART, are Defendants, the Clerk of Court will sell to the highest and best bidder for cash electronically at www.pasco.realforeclose.com in accordance with Chapter 45, Florida Statutes on the 25th day of April, 2014 at 11:00 AM on the following described property as set forth in said Summary Final Judgment, to-wit:

Lot 71, Ridge Crest Gardens First Addition, according to the Plat thereof as recorded in Plat Book 13, Pages 86 through 88, of the Public Records of Pasco County, Florida

Any person claiming an interest in the surplus from the sale, if any, other than the property owner as of the date of the lis pendens, must file a claim within 60 days after the sale.

If you are a person with a disability who needs any accommodation in order to participate in this proceeding, you are entitled, at no cost to you to the provision of certain assistance. Within two (2) working days

of your receipt of this (describe notice/order) please contact the Public Information Dept., Pasco County Government Center, 7530 Little Rd., New Port Richey, FL 34654; (727) 847-8110 (V) in New Port Richey; (352) 521-4274, ext. 8110 (V) in Dade City; via 1-800-955-8771 if you are hearing impaired. The court does not provide transportation and cannot accommodate for this service. Persons with disabilities needing transportation to court should contact their local public transportation providers for information regarding disabled transportation services.

ROBYN KATZ FLORIDA BAR NO.: 0146803 Marie D. Campbell, Esq. Fla. Bar No.: 543357

McCalla Raymer, LLC Attorney for Plaintiff 225 E. Robinson St. Suite 660 Orlando, FL 32801 Phone: (407) 674-1850 Fax: (321) 248-0420 Email: MRService@mccallaraymer.com 2458432 10-02909-5 April 4, 11, 2014 14-02008P

SAVE TIME

E-mail your Legal Notice

legal@businessobserverfl.com

Business Observer

Wednesday Noon Deadline Friday Publication

## FIRST INSERTION

NOTICE OF ACTION  
IN THE CIRCUIT COURT OF THE  
SIXTH JUDICIAL CIRCUIT OF  
FLORIDA IN AND  
FOR PASCO COUNTY  
GENERAL JURISDICTION  
DIVISION  
CASE NO.

**2013CA005600CAAXWS/J2  
CALIBER HOME LOANS, INC.,  
Plaintiff, vs.  
ROBIN GRANADOS, et al.,  
Defendants.**

To: COLLEEN M. GRANADOS  
20 Crum Elbow Rd., Apt. 11D  
Hyde Park, NY 12538  
LAST KNOWN ADDRESS STATED,  
CURRENT RESIDENCE UNKNOWN  
YOU ARE HEREBY NOTIFIED  
that an action to foreclose Mortgage  
covering the following real and personal  
property described as follows,  
to-wit:

LOT 1879, REGENCY PARK  
UNIT TWELVE, ACCORDING  
TO THE PLAT THEREOF, AS  
RECORDED IN PLAT BOOK  
16, PAGES 7-9, OF THE PUBLIC  
RECORDS OF PASCO  
COUNTY, FLORIDA.

has been filed against you and you  
are required to a copy of your written  
defenses, if any, to it on Marie  
D. Campbell, McCalla Raymer,  
LLC, 225 E. Robinson St. Suite  
660, Orlando, FL 32801 and file  
the original with the Clerk of the  
above- styled Court on or before  
30 days from the first publication,  
otherwise a Judgment may be entered  
against you for the relief demanded  
in the Complaint. \*on or  
before 5/5

If you are a person with a disability  
who needs any accommodation  
in order to participate in this  
proceeding, you are entitled,  
at no cost to you, to the provision  
of certain assistance. Please contact  
the Public Information Dept.,  
Pasco County Government Center,  
7530 Little Rd., New Port Richey,  
FL 34654; (727) 847-8110 (V) in  
New Port Richey; (352) 521-4274,  
ext 8110 (V) in Dade City, at least  
7 days before your scheduled court  
appearance, or immediately upon  
receiving this notification if the  
time before the scheduled appearance  
is less than 7 days; if you are  
hearing impaired call 711. The  
court does not provide transportation  
and cannot accommodate for  
this service. Persons with disabilities  
needing transportation to court  
should contact their local public  
transportation providers for  
information regarding transportation  
services.

WITNESS my hand and seal of said  
Court on the 27 day of March, 2014.

Paula S. O'Neil, Ph.D.,  
Clerk & Comptroller  
CLERK OF THE CIRCUIT COURT  
As Clerk of the Court  
BY: Sarah Levell  
Deputy Clerk  
Marie D. Campbell  
MCCALLA RAYMER, LLC  
225 E. Robinson St. Suite 660  
Orlando, FL 32801  
Phone: (407) 674-1850  
Fax: (321) 248-0420  
2551615  
13-03193-1  
April 4, 11, 2014 14-01957P

## FIRST INSERTION

NOTICE OF ACTION  
IN THE CIRCUIT COURT OF THE  
SIXTH JUDICIAL CIRCUIT IN AND  
FOR PASCO COUNTY, FLORIDA  
CASE NO.:

**2014CA000263CAAXWS/J3  
THE BANK OF NEW YORK  
MELLON FK A THE BANK  
OF NEW YORK SUCCESSOR  
TRUSTEE TO JPMORGAN CHASE  
BANK, N.A., AS TRUSTEE FOR  
THE STRUCTURED ASSET  
MORTGAGE INVESTMENTS II  
TRUST, MORTGAGE  
PASS-THROUGH CERTIFICATES,  
SERIES 2006-ARI,  
Plaintiff, vs.  
SHARON K. ISAACS; SIMON W.  
ISAACS; et al.,  
Defendant(s).**

TO: Sharon K. Isaacs  
Last Known Residence: 1431 Jennings  
Drive, Holiday, FL 34690  
Simon W. Isaacs  
Last Known Residence: 1431 Jennings  
Drive, Holiday, FL 34690

YOU ARE HEREBY NOTIFIED  
that an action to foreclose a mortgage  
on the following property in PASCO  
County, Florida:

LOT 32, MIDWAY ACRES  
UNIT ONE. ACCORDING TO  
THE PLAT THEREOF AS RECORDED  
IN PLAT BOOK 7,  
PAGE 22 OF THE PUBLIC RECORDS  
OF PASCO COUNTY,  
FLORIDA.

has been filed against you and you  
are required to serve a copy of your  
written defenses, if any, to it on  
ALDRIDGE | CONNORS, LLP,  
Plaintiff's attorney,  
at 1615 South Congress Avenue,  
Suite 200, Delray Beach, FL 33445 (Phone

Number: (561) 392-6391), within 30  
days of the first date of publication  
of this notice, and file the original  
with the clerk of this court either  
before May 5, 2014 on Plaintiff's  
attorney or immediately thereafter;  
otherwise a default will be entered  
against you for the relief demanded  
in the complaint or petition.

If you are a person with a disability  
who needs any accommodation in  
order to participate in this proceeding,  
you are entitled, at no cost to you,  
to the provision of certain assistance.  
Please contact the Public Information  
Dept., Pasco County Government  
Center, 7530 Little Rd., New Port  
Richey, FL 34654; (727) 847-8110  
(V) in New Port Richey; (352) 521-4274,  
ext 8110 (V) in Dade City, at least  
7 days before your scheduled court  
appearance, or immediately upon  
receiving this notification if the  
time before the scheduled appearance  
is less than 7 days; if you are  
hearing impaired call 711. The court  
does not provide transportation and  
cannot accommodate for this service.  
Persons with disabilities needing  
transportation to court should contact  
their local public transportation  
providers for information regarding  
transportation services.

Dated on March 27, 2014.  
PAULA O'NEIL  
As Clerk of the Court  
By: /s/ Jonathon Martin  
As Deputy Clerk  
ALDRIDGE | CONNORS, LLP  
Plaintiff's attorney  
1615 South Congress Avenue,  
Suite 200  
Delray Beach, FL 33445  
(Phone Number: (561) 392-6391)  
1190-689B  
April 4, 11, 2014 14-01975P

## FIRST INSERTION

NOTICE OF ACTION  
IN THE CIRCUIT COURT OF THE  
SIXTH JUDICIAL CIRCUIT, IN AND  
FOR PASCO COUNTY, FLORIDA  
CASE NO.

**2014CA000438CAAXWS/J2  
CITIMORTGAGE, INC.  
Plaintiff, vs.  
THERESA L. COX A/K/A THERESA  
TLC FAIRLADY, et al  
Defendant(s).**

TO: THERESA L. COX A/K/A THERESA  
TLC FAIRLADY  
RESIDENT: Unknown  
LAST KNOWN ADDRESS: 5249 SEA  
FOREST DRIVE, NEW PRT RCHY,  
FL 34652-3210

YOU ARE HEREBY NOTIFIED  
that an action to foreclose a mortgage  
on the following described property  
located in PASCO County, Florida:  
Lot 2369, Regency Park, Unit  
Sixteen, according to the plat  
thereof as recorded in Plat Book  
17, Pages 30-32 of the Public  
Records of Pasco County, Florida.

has been filed against you, and you  
are required to serve a copy to your  
written defenses, if any, to this  
action on Phelan Hallinan, PLC,  
attorneys for plaintiff, whose  
address is 2727 West Cypress Creek  
Road, Ft. Lauderdale, FL 33309,  
and file the original with the Clerk  
of the Court, within 30 days after  
the first publication of this notice,  
either before or immediately  
thereafter, May 5, 2014 otherwise  
a default may be entered against  
you for the relief demanded in the  
Complaint.

This notice shall be published once a  
week for two consecutive weeks in the

Business Observer.

Movant counsel certifies that a bona  
fide effort to resolve this matter on  
the motion noticed has been made or  
that, because of time consideration,  
such effort has not yet been made  
but will be made prior to the  
scheduled hearing.

If you are a person with a disability  
who needs any accommodation  
to participate in this proceeding,  
you are entitled, at no cost to you,  
to the provision of certain assistance.  
Please contact the Public Information  
Dept., Pasco County Government  
Center, 7530 Little Rd., New Port  
Richey, FL 34654; (727) 847-8110  
(V) in New Port Richey; (352) 521-4274,  
ext 8110 (V) in Dade City, at least  
7 days before your scheduled court  
appearance, or immediately upon  
receiving this notification if the  
time before the scheduled appearance  
is less than seven (7) days; if you  
are hearing or voice impaired, call  
711.

The court does not provide transportation  
and cannot accommodate for this  
service. Persons with disabilities  
needing transportation to court should  
contact their local public transportation  
providers for information regarding  
transportation services.

DATED: 3/27/14  
Paula S. O'Neil, Ph.D.,  
Clerk & Comptroller  
Clerk of the Circuit Court  
By: /s/ Jonathon Martin  
Deputy Clerk of the Court

Phelan Hallinan, PLC  
2727 West Cypress Creek Road  
Ft. Lauderdale, FL 33309  
PH # 48401  
April 4, 11, 2014 14-01976P

## FIRST INSERTION

NOTICE OF ACTION  
IN THE CIRCUIT COURT OF THE  
SIXTH JUDICIAL CIRCUIT IN AND  
FOR PASCO COUNTY, FLORIDA  
CASE NO.: 51-2013-CA-005893/J6  
WELLS FARGO BANK N.A., as  
trustee on behalf of GREEN TREE  
2008-MH1, acting by and through  
GREEN TREE SERVICING LLC, as  
Servicing Agent 345 St. Peter Street  
1100 Landmark Towers St. Paul,  
MN 55102,  
Plaintiff, v.

THE UNKNOWN HEIRS,  
DEVISEES, GRANTEEES,  
ASSIGNEES, CREDITORS,  
LIENORS AND TRUSTEES OF  
WILLIAM DOOLEY, DECEASED,  
AND ANY OTHER PERSONS  
CLAIMING BY, THROUGH,  
UNDER, AND AGAINST THE  
NAMED DEFENDANT, TERESA  
A. COHEE, CHASE BANK USA,  
N.A., MUKESH PATEL, M.D.,  
P.A., DISCOVER BANK, MBNA  
AMERICA BANK, N.A. d/b/a  
BANK OF AMERICA, N.A.,  
THE UNKNOWN TENANT  
IN POSSESSION OF 12317  
PARKWOOD STREET, HUDSON,  
FL 34669,  
Defendants.

TO: THE UNKNOWN HEIRS,  
DEVISEES, GRANTEEES,  
ASSIGNEES, CREDITORS,  
LIENORS AND TRUSTEES OF  
WILLIAM DOOLEY,  
DECEASED, AND ANY OTHER  
PERSONS CLAIMING BY,  
THROUGH, UNDER, AND  
AGAINST THE NAMED  
DEFENDANT:

YOU ARE NOTIFIED that a civil  
action has been filed against you  
in the Circuit Court, County of Pasco,  
State of Florida, to foreclose certain  
real property described as follows:

TRACT 191 OF THE UNRECORDED  
PLAT OF PARKWOOD ACRES,  
UNIT 2, BEING FURTHER DESCRIBED  
AS FOLLOWS: COMMENCING  
AT THE NE CORNER OF THE SE  
1/4 OF SECTION 1, TOWNSHIP 25  
SOUTH, RANGE 16 EAST, PASCO  
COUNTY, FLORIDA, GO  
THENCE N 89 DEGREES 02'55"  
W AND ALONG THE NORTH LINE OF  
THE AFORESAID SE 1/4 A DISTANCE  
OF 425'; THENCE S 00 DEGREES  
51'07" W, A DISTANCE OF 825'  
TO THE POINT OF BEGINNING,  
THENCE CONTINUE S 00 DEGREES  
51'07" W, A DISTANCE OF 100'  
THENCE N 89 DEGREES 02'55"  
W, A DISTANCE OF 175'; THENCE  
N 00 DEGREES 51' 07" E, A  
DISTANCE OF 100'; THENCE S 89  
DEGREES 02'55" E, A DISTANCE  
OF 175' TO THE POINT OF  
BEGINNING; TOGETHER WITH  
THAT CERTAIN 1999 CELEB 48'  
MOBILE HOME SERIAL NUMBERS  
FLFLW70A26821CE21 & FL-  
FLW70B26821CE21.

Commonly known as: 12317  
PARKWOOD STREET, HUDSON,  
FL 34669.

You are required to file a written  
response with the Court and serve  
a copy of your written defenses, if  
any, to it on Timothy D. Padgett,  
Plaintiff's attorney, whose address  
is 6267 Old Water Oak Road,  
Suite 203, Tallahassee, Florida  
32312, at least thirty (30) days  
from the date of first publication,  
and file the original

with the clerk of this court either  
before service on Plaintiff's attorney  
or immediately thereafter; otherwise,  
a default will be entered against  
you for the relief demanded in the  
complaint. On or before 5/5/14

If you are a person with a disability  
who needs any accommodation  
in order to participate in this  
proceeding, you are entitled, at no  
cost to you, to the provision of  
certain assistance. Please contact  
the Public Information Dept., Pasco  
County Government Center, 7530  
Little Rd., New Port Richey, FL  
34654; (727) 847-8110 (V) in New  
Port Richey; (352) 521-4274, ext  
8110 (V) in Dade City, at least 7  
days before your scheduled court  
appearance, or immediately upon  
receiving this notification if the  
time before the scheduled appearance  
is less than 7 days; if you are  
hearing impaired call 711. The court  
does not provide transportation and  
cannot accommodate for this  
service. Persons with disabilities  
needing transportation to court  
should contact their local public  
transportation providers for  
information regarding transportation  
services.

Dated this 27 day of March, 2014.  
Paula S. O'Neil, Ph.D.,  
Clerk & Comptroller  
CLERK OF COURT  
By: /s/ Jonathon Martin  
Deputy Clerk

Attorney for Plaintiff:  
Timothy D. Padgett, P.A.  
6267 Old Water Oak Road, Suite 203  
Tallahassee, FL 32312  
Attorney@padgettlaw.net  
(850) 422-2520 (phone)  
(850) 422-2567 (fax)  
April 4, 11, 2014 14-01974P

## FIRST INSERTION

NOTICE OF ACTION  
IN THE CIRCUIT COURT OF THE  
SIXTH JUDICIAL CIRCUIT IN AND  
FOR PASCO COUNTY, FLORIDA  
CIVIL DIVISION  
CASE NO.: 51-2009-CA-008339WS  
DIVISION: J2

**BANK OF AMERICA, N.A.,  
SUCCESSOR BY MERGER TO  
BAC HOME LOANS SERVICING,  
LP F/K/A COUNTRYWIDE HOME  
LOANS SERVICING, LP  
Plaintiff, v.**

**THE UNKNOWN SPOUSE,  
HEIRS, DEVISEES, GRANTEEES,  
ASSIGNEES, LIENORS,  
CREDITORS, TRUSTEES  
AND ALL OTHERS PARTIES  
CLAIMING AN INTEREST BY,  
THROUGH, UNDER OR AGAINST  
THE ESTATE OF BRIAN A.  
MCKEON, DECEASED; BANK  
OF AMERICA, NATIONAL  
ASSOCIATION; JOHN P.  
MCKEON; RICHARD MCKEON;  
JACQUELINE MCKEON; MARIAN  
MCKEON; PATRICIA MCKEON;  
JOHN DOE AND JANE DOE  
AS UNKNOWN TENANTS IN  
POSSESSION,  
Defendant(s).**

TO: JACQUELINE MCKEON  
Last Known Address:  
510 E 20th Street Apt. 3A  
New York, NY 10009  
Current Address: Unknown  
Previous Address: Unknown  
TO: MARION MCKEON  
Last Known Address:  
1868 Nitas Place  
Wantagh, New York 11793  
Current Address: Unknown  
Previous Address: Unknown  
TO: THE UNKNOWN SPOUSE,  
HEIRS, DEVISEES, GRANTEEES, AS-

SIGNEES, LIENORS, CREDITORS,  
TRUSTEES AND ALL OTHERS PARTIES  
CLAIMING AN INTEREST BY,  
THROUGH, UNDER OR AGAINST  
THE ESTATE OF BRIAN A. MCKEON,  
DECEASED

whose residence is unknown if he/  
she/they be living; and if he/she/  
they be dead, the unknown Defendants  
who may be spouses, heirs, devisees,  
grantees, assignees, lienors, creditors,  
trustees, and all parties claiming an  
interest by, through, under or against  
the Defendants, who are not known  
to be dead or alive, and all parties  
having or claiming to have any right,  
title or interest in the property  
described in the mortgage being  
foreclosed herein

YOU ARE NOTIFIED that an action  
to foreclose a mortgage on the  
following property in Pasco County,  
Florida:  
LOT 1399, EMBASSY HILLS,  
UNIT SEVENTEEN, ACCORDING  
TO THE MAP OR PLAT THEREOF  
AS RECORDED IN PLAT BOOK 16,  
PAGES 1 AND 2, PUBLIC RECORDS  
OR PASCO COUNTY, FLORIDA.

This property is located at the  
Street address of: 9121 Haverford  
Lane, Port Richey, Florida 34668

YOU ARE REQUIRED to serve a  
copy of your written defenses on or  
before MAY 5, 2014 a date which  
is within 30 days after the first  
publication, if any, on Elizabeth R.  
Wellborn, P.A., Plaintiff's Attorney,  
whose address is 350 Jim Moran  
Blvd., Suite 100, Deerfield Beach,  
Florida 33442, and file the original  
with this Court either before service  
on Plaintiff's Attorney, or immediately  
thereafter; otherwise, a default  
will be entered against you for the  
relief demanded in the Complaint or

Petition.

This Notice shall be published once  
a week for two consecutive weeks  
in Business Observer.

\*\*IN ACCORDANCE WITH THE  
AMERICAN'S WITH DISABILITIES  
ACT, If you are a person with a  
disability who needs any  
accommodation in order to  
participate in this proceeding,  
you are entitled at no cost to you,  
to the provision of certain  
assistance. Please contact:  
Public Information Dept., Pasco  
County Government Center,  
7530 Little Rd., New Port Richey,  
FL 34654; (727) 847-8110 (voice)  
for proceedings in New Port  
Richey; (352) 521-4274, ext 8110  
(voice) for proceedings in Dade  
City at least 7 days before your  
scheduled court appearance, or  
immediately upon receiving this  
notification if the time before the  
scheduled appearance is less than  
7 days; if you are hearing or  
voice impaired, call 711.

WITNESS my hand and the seal of  
the court on MARCH 27, 2014

Paula S. O'Neil, Ph.D.,  
Clerk & Comptroller  
CLERK OF THE CIRCUIT COURT  
By: /s/ Denise Allie  
Deputy Clerk  
(COURT SEAL)

Attorney for Plaintiff:  
Brian Streicher, Esquire  
Arlisa Certain, Esquire

Elizabeth R. Wellborn, P.A.  
350 Jim Moran Blvd., Suite 100  
Deerfield Beach, FL 33442  
Telephone: (954) 354-3544  
Facsimile: (954) 354-3545  
Primary email:  
bstreicher@erwlaw.com  
Secondary email:  
servicecomplete@erwlaw.com  
8377ST-26464  
April 4, 11, 2014 14-01959P

## FIRST INSERTION

NOTICE OF ACTION  
IN THE CIRCUIT COURT OF THE  
SIXTH JUDICIAL CIRCUIT IN AND  
FOR PASCO COUNTY, FLORIDA  
CIVIL ACTION  
CASE NO.:

**51-2008-CA-008150-WS/J3  
WELLS FARGO BANK, N.A.,  
Plaintiff, vs.  
THE UNKNOWN HEIRS,  
DEVISEES, GRANTEEES,  
ASSIGNEES, LIENORS,  
CREDITORS, TRUSTEES, OR  
OTHER CLAIMANTS CLAIMING  
BY, THROUGH, UNDER, OR  
AGAINST, JAMES H. RISENER,  
DECEASED, et al,  
Defendant(s).**

To: ANGELA MARIE SIDDEES  
A/K/A ANGELA SIDDEES, AS AN  
HEIR OF THE ESTATE OF JAMES  
H. RISENER A/K/A JAMES HENRY  
RISENER A/K/A JAMES RISENER,  
DECEASED

Last Known Address:  
10300 Tecoma Dr  
Trinity, FL 34655  
Current Address: Unknown  
THE UNKNOWN HEIRS, DEVISEES,  
GRANTEEES, ASSIGNEES,  
LIENORS, CREDITORS, TRUSTEES,

OR OTHER CLAIMANTS CLAIMING  
BY, THROUGH, UNDER, OR  
AGAINST, JAMES H. RISENER  
A/K/A JAMES HENRY RISENER  
A/K/A JAMES RISENER,  
DECEASED

Last Known Address: Unknown  
Current Address: Unknown  
ANY AND ALL UNKNOWN PARTIES  
CLAIMING BY, THROUGH,  
UNDER, AND AGAINST THE  
HEREIN NAMED INDIVIDUAL  
DEFENDANT(S) WHO ARE NOT  
KNOWN TO BE DEAD OR ALIVE,  
WHETHER SAID UNKNOWN PARTIES  
MAY CLAIM AN INTEREST AS  
SPOUSES, HEIRS, DEVISEES,  
GRANTEEES, OR OTHER CLAIMANTS

Last Known Address: Unknown  
Current Address: Unknown  
YOU ARE NOTIFIED that an action  
to foreclose a mortgage on the  
following property in Pasco County,  
Florida:  
LOT 170, AUTUMN OAKS  
UNIT THREE-A, ACCORDING  
TO THE PLAT THEREOF  
RECORDED IN PLAT BOOK  
28, PAGES 85 AND 86, PUBLIC  
RECORDS OF PASCO COUNTY,

FLORIDA.  
A/K/A 18163 WINDING OAKS  
BOULEVARD, HUDSON, FL  
34667

has been filed against you and you  
are required to serve a copy of your  
written defenses within 30 days after  
the first publication, if any, on Albertelli  
Law, Plaintiff's attorney, whose  
address is P.O. Box 23028, Tampa, FL  
33623, and file the original with this  
Court either before 5/5/14 service on  
Plaintiff's attorney, or immediately  
thereafter; otherwise, a default will  
be entered against you for the relief  
demanded in the Complaint or petition.

This notice shall be published once a  
week for two consecutive weeks in the  
Business Observer.

\*\*See the Americans with Disabilities  
Act  
If you are a person with a disability  
who needs any accommodation in  
order to participate in this proceeding,  
you are entitled, at no cost to you,  
to the provision of certain assistance.  
Please contact:

Public Information Dept., Pasco  
County Government Center 7530  
Little Rd. New Port Richey, FL 34654

Phone: 727.847.8110 (voice) in New  
Port Richey 352.521.4274, ext 8110  
(voice) in Dade City Or 711 for the  
hearing impaired

Contact should be initiated at least  
seven days before the scheduled court  
appearance, or immediately upon  
receiving this notification if the  
time before the scheduled appearance  
is less than seven days.

The court does not provide transportation  
and cannot accommodate such  
requests. Persons with disabilities  
needing transportation to court should  
contact their local public transportation  
providers for information regarding  
transportation services.

WITNESS my hand and the seal of  
this court on this 27 day of March,  
2014.

Paula S. O'Neil, Ph.D.,  
Clerk & Comptroller  
Clerk of the Circuit Court  
By: /s/ Sarah Lovell  
Deputy Clerk

Please send invoice and copy to:  
Albertelli Law  
P.O. Box 23028  
Tampa, FL 33623  
PH - 08-09320  
April 4, 11, 2014 14-01958P

Subscribe to the  
**Business  
Observer...**

Visit our website at

**Businessobserverfl.com**

to sign up today!

SUBSEQUENT INSERTIONS

SECOND INSERTION

NOTICE TO CREDITORS IN THE CIRCUIT COURT FOR PASCO COUNTY, FLORIDA PROBATE DIVISION  
**File No. 51-2014-CP-000105-WS/J**  
**IN RE: ESTATE OF PAULA M. HANCOCK**  
 Deceased.

The administration of the estate of PAULA M. HANCOCK, deceased, whose date of death was October 16, 2013, is pending in the Circuit Court for Pasco County, Florida, Probate Division, the address of which is 7530 Little Road, New Port Richey, FL 34654. The names and addresses of the Personal Representative and the Personal Representative's attorney are set forth below.

All creditors of the decedent and other persons having claims or demands against decedent's estate on whom a copy of this notice is required to be served must file their claims with this court ON OR BEFORE THE LATER OF THREE (3) MONTHS AFTER THE TIME OF THE FIRST PUBLICATION OF THIS NOTICE OR THIRTY (30) DAYS AFTER THE DATE OF SERVICE OF A COPY OF THIS NOTICE ON THEM.

All other creditors of the decedent and other persons having claims or demands against decedent's estate must file their claims with this court WITHIN THREE (3) MONTHS AFTER THE DATE OF THE FIRST PUBLICATION OF THIS NOTICE.

ALL CLAIMS NOT FILED WITHIN THE TIME PERIODS SET FORTH IN SECTION 733.702 OF THE FLORIDA PROBATE CODE WILL BE FOREVER BARRED.

NOTWITHSTANDING THE TIME PERIODS SET FORTH ABOVE, ANY CLAIM FILED TWO (2) YEARS OR MORE AFTER THE DECEDENT'S DATE OF DEATH IS BARRED.

The date of first publication of this notice is March 28, 2014.

**Personal Representative:**  
**William G. Hancock**  
 5033 Springland Drive  
 Holiday, FL 34690

Attorney for Personal Representative:  
**Barbara J. Hunting, Esquire**  
 Florida Bar No. 0971014  
**Barbara J. Hunting, P.A.**  
 2706 Alt. 19 North, Suite 310  
 Palm Harbor, FL 34683-2643  
 727-772-5804  
 E-mail: info@bhuntinglaw.com  
 Mar. 28; Apr. 4, 2014 14-01810P

SECOND INSERTION

NOTICE TO CREDITORS IN THE CIRCUIT COURT FOR THE SIXTH JUDICIAL CIRCUIT PASCO COUNTY, FLORIDA PROBATE DIVISION  
**File No.**  
**2014-CP-000247**  
**IN RE: ESTATE OF HERBERT A. BECKER,**  
 Deceased.

The administration of the estate of HERBERT A. BECKER, deceased, whose date of death was February 3, 2014; File Number 2014-CP-000247, is pending in the Circuit Court for Pasco County, Florida, Probate Division, the address of which is 38053 Live Oak Avenue, Dade City, Florida 33523-3894. The names and addresses of the personal representative and the personal representative's attorney are set forth below.

All creditors of the decedent and other persons having claims or demands against decedent's estate, on whom a copy of this notice is required to be served, must file their claims with this court WITHIN THE LATER OF THREE (3) MONTHS AFTER THE TIME OF THE FIRST PUBLICATION OF THIS NOTICE OR 30 DAYS AFTER THE DATE OF SERVICE OF A COPY OF THIS NOTICE ON THEM.

All other creditors of the decedent and other persons having claims or demands against decedent's estate must file their claims with this court WITHIN 3 MONTHS AFTER THE DATE OF THE FIRST PUBLICATION OF THIS NOTICE.

ALL CLAIMS NOT FILED WITHIN THE TIME PERIODS SET FORTH IN SECTION 733.702 OF THE FLORIDA PROBATE CODE WILL BE FOREVER BARRED.

NOTWITHSTANDING THE TIME PERIOD SET FORTH ABOVE, ANY CLAIM FILED TWO (2) YEARS OR MORE AFTER THE DECEDENT'S DATE OF DEATH IS BARRED.

The date of first publication of this notice is MARCH 28, 2014.

Signed on February 21, 2014  
**MARY ANN BENNETT**  
**Personal Representative**  
 9267 US Highway 98, Lot 94  
 Dade City, Florida 33525

William E. Gaylor, III  
 Attorney for Personal Representative  
 Email: chip.gaylor@mgswlaw.com  
 Florida Bar No. 0834350  
 Muirhead, Gaylor, Steves & Waskom, P.A.  
 901 Ridgewood Avenue  
 Venice, Florida 34285  
 Telephone: (941) 484-3000  
 Mar. 28; Apr. 4, 2014 14-01825P

SECOND INSERTION

NOTICE TO CREDITORS IN THE CIRCUIT COURT FOR PASCO COUNTY, FLORIDA PROBATE DIVISION  
**File No. 51-14-CP-0254-WS**  
**Section: J**  
**IN RE: ESTATE OF LEWIS A. SUTTON,**  
 Deceased.

The administration of the estate of Lewis A. Sutton, deceased, whose date of death was February 10, 2014, and whose Social Security Number is N/A is pending in the Circuit Court of Pasco County, Florida, Probate Division, the address of which is 7530 Little Road, New Port Richey, FL 34654. The names and addresses of the Co-Personal Representatives and the Co-Personal Representatives' attorney are set forth below.

All creditors of the decedent and other persons having claims or demands against decedent's estate, on whom a copy of this notice is required to be served must file their claims with this court WITHIN THE LATER OF THREE (3) MONTHS AFTER THE TIME OF THE FIRST PUBLICATION OF THIS NOTICE OR THIRTY (30) DAYS AFTER THE DATE OF SERVICE OF A COPY OF THIS NOTICE ON THEM.

All other creditors of the decedent and other persons having claims or demands against decedent's estate must file their claims with this court WITHIN THREE (3) MONTHS AFTER THE DATE OF THE FIRST PUBLICATION OF THIS NOTICE.

ALL CLAIMS NOT SO FILED WITHIN THE TIME PERIODS SET FORTH IN SECTION 733.702 OF THE FLORIDA PROBATE CODE WILL BE FOREVER BARRED.

NOTWITHSTANDING THE TIME PERIOD SET FORTH ABOVE, ANY CLAIM FILED TWO (2) YEARS OR MORE AFTER THE DECEDENT'S DATE OF DEATH IS BARRED.

THE DATE OF FIRST PUBLICATION OF THIS NOTICE IS March 28, 2014.

**Co-Personal Representatives:**  
**Renee I. Sutton**  
 17256 Via Chiquita  
 San Lorenzo, CA 94580  
**Roxanne E. Sutton**  
 7817 Louise Avenue  
 Northridge, CA 91325

Attorney for Co-Personal Representatives:  
 David C. Gilmore, Esq.  
 7620 Massachusetts Avenue  
 New Port Richey, FL 34653  
 (727) 849-2296  
 FBN 323111  
 Mar. 28; Apr. 4, 2014 14-01833P

SECOND INSERTION

NOTICE TO CREDITORS IN THE CIRCUIT COURT FOR PASCO COUNTY, FLORIDA PROBATE DIVISION  
**File No. 512014CP000141CPAXWS**  
**Division: Probate**  
**IN RE: ESTATE OF RICHARD LEE YOUNG A/K/A RICHARD L. YOUNG**  
 Deceased.

The administration of the estate of Richard Lee Young a/k/a Richard L. Young, deceased, whose date of death was September 26, 2013 and whose Social Security Number is XXX-XX-3710 is pending in the Circuit Court for Pasco County, Florida, Probate Division, the address of which is P.O. Box 338, New Port Richey, Florida 34656. The names of the Personal Representative and Personal Representative's attorney are set forth below.

All creditors of the decedent and other persons having claims or demands against decedent's estate, on whom a copy of this notice is served must file their claims with this court WITHIN THE LATER OF THREE (3) MONTHS AFTER THE DATE OF THE FIRST PUBLICATION OF THIS NOTICE OR THIRTY (30) DAYS AFTER THE DATE OF SERVICE OF A COPY OF THIS NOTICE ON THEM.

All other creditors of the decedent and other persons having claims or demands against decedent's estate, must file their claims with this court WITHIN THREE (3) MONTHS AFTER THE DATE OF THE FIRST PUBLICATION OF THIS NOTICE.

ALL CLAIMS NOT SO FILED WITHIN THE TIME PERIODS SET FORTH IN SECTION 733.702 OF THE FLORIDA PROBATE CODE WILL BE FOREVER BARRED.

NOTWITHSTANDING THE TIME PERIOD SET FORTH ABOVE, ANY CLAIM FILED TWO (2) YEARS OR MORE AFTER THE DECEDENT'S DATE OF DEATH IS BARRED.

The date of first publication of this Notice is March 28, 2014.

**Personal Representative:**  
**Kathy S. Royer**  
 1210 East 191st Street  
 Westfield, Indiana 46074

Attorney for Personal Representative:  
 Tanya Bell, Esquire  
 Attorney for Petitioner  
 Florida Bar No. 0052924  
 UAW Legal Services Plan  
 2454 McMullen Booth Road,  
 Bldg. B - Suite 425  
 Clearwater, FL 33759  
 Telephone: (727) 669-5319  
 or (877) 309-1787  
 Facsimile: (727)669-0978  
 tanyabe@uawls.com  
 Mar. 28; Apr. 4, 2014 14-01871P

SECOND INSERTION

NOTICE TO CREDITORS IN THE CIRCUIT COURT OF THE FIFTH JUDICIAL CIRCUIT IN AND FOR PASCO COUNTY, FLORIDA PROBATE DIVISION  
**File No.**  
**51-2014-CP-000240CPAXWS**  
**Division: I**  
**IN RE: ESTATE OF FLORENCE HILBERT,**  
 Deceased.

The administration of the estate of FLORENCE HILBERT a/k/a FLORENCE E. HILBERT, deceased, whose date of death was January 29, 2014, and whose social security number is XXX-XX-8961, File No. 51-2014-CP-000240CPAXWS, is pending in the Circuit Court for Pasco County, Florida, Probate Division, the address of which is 7530 Little Road, #104, New Port Richey, FL 34654. The names and addresses of the personal representative and the personal representative's attorney are set forth below.

All creditors of the decedent and other persons having claims or demands against decedent's estate on whom a copy of this notice is required to be served must file their claims with this court WITHIN THE LATER OF 3 MONTHS AFTER THE TIME OF THE FIRST PUBLICATION OF THIS NOTICE OR 30 DAYS AFTER THE DATE OF SERVICE OF A COPY OF THIS NOTICE ON THEM.

All other creditors of the decedent and other persons having claims or demands against decedent's estate must file their claims with this court WITHIN 3 MONTHS AFTER THE DATE OF THE FIRST PUBLICATION OF THIS NOTICE.

ALL CLAIMS NOT FILED WITHIN THE TIME PERIODS SET FORTH IN SECTION 733.702 OF THE FLORIDA PROBATE CODE WILL BE FOREVER BARRED.

NOTWITHSTANDING THE TIME PERIODS SET FORTH ABOVE, ANY CLAIM FILED TWO (2) YEARS OR MORE AFTER THE DECEDENT'S DATE OF DEATH IS BARRED.

The date of first publication of this notice is March 28, 2014.

**Personal Representative:**  
**Barbara J. Hunting, Esq.**  
 2706 Alt. 19 North #310  
 Palm Harbor, FL 34683

Attorney for Personal Representative:  
 Larry J. Gonzales, Esquire  
 Email address:  
 lgonzales@lgonzaleslaw.com  
 Florida Bar No. 0615978  
 2706 Alt. 19 North, Suite 308  
 Palm Harbor, Florida 34683  
 Telephone: (727) 791-8002  
 Facsimile: (727) 475-1498  
 Mar. 28; Apr. 4, 2014 14-01924P



E-mail your Legal Notice

legal@businessobserverfl.com

Sarasota County  
 Manatee County  
 Hillsborough County  
 Pinellas County  
 Pasco County  
 Lee County  
 Collier County  
 Charlotte County

Wednesday Noon Deadline  
 Friday Publication



SECOND INSERTION

NOTICE OF FORECLOSURE SALE IN THE CIRCUIT COURT OF THE 6TH JUDICIAL CIRCUIT, IN AND FOR PASCO COUNTY, FLORIDA GENERAL JURISDICTION DIVISION

**CASE NO: 51-2012-CA-005176WS**  
**THE BANK OF NEW YORK MELLON FKA THE BANK OF NEW YORK, AS TRUSTEE FOR THE CERTIFICATEHOLDERS OF CWABS, INC., ASSET-BACKED CERTIFICATES, SERIES 2007-2,**  
**Plaintiff, vs.**  
**DAVID W. BREWSTER, ASHLEY R. BREWSTER, WATERS EDGE MASER ASSOCIATION, INC, WATERS EDGE PATIO HOMES HOMEOWNERS ASSOCIATION, INC: UNKNOWN TENANT(S) IN POSSESSION #1 AND #2, AND ALL OTHER UNKNOWN PARTIES, INCLUDING, IF A NAMED DEFENDANT IS DECEASED, IN PERSONAL REPRESENTATIVES, THE SURVIVING SPOUSE, HEIRS, DEVISEES, GRANTEEES, CREDITORS, AND ALL CLAIMING, BY, THROUGH, UNDER OR AGAINST THAT DEFENDANT, AND ALL CLAIMANTS, PERSONS OR PARTIES, NATURAL OR CORPORATE, OR WHOSE EXACT LEGAL STATUS IS UNKNOWN, CLAIMING UNDER ANY OF THE ABOVE NAMED DESCRIBED DEFENDANTS,**  
**Defendant(s).**

NOTICE IS HEREBY GIVEN pursuant to a Uniform Final Judgment of Foreclosure dated March 5, 2014 entered in Civil Case No. 51-2012-CA-005176WS of the Circuit Court of the 6th Judicial Circuit in and for Pasco County, Florida, wherein THE BANK OF NEW YORK MELLON FKA THE BANK OF NEW YORK, AS TRUSTEE FOR THE CERTIFICATEHOLDERS OF CWABS, INC., ASSET-BACKED CERTIFICATES, SERIES 2007-2 is Plaintiff and DAVID W. BREWSTER and ASHLEY R. BREWSTER, et al, are Defendants. The Clerk shall sell to the highest and best bidder for cash at PASCO COUNTY'S ON-LINE PUBLIC AUCTION website: www.pasco.realforeclose.com, at 11:00 A.M. on

June 3, 2014, the following described property as set forth in said Uniform Final Judgment of Foreclosure, to-wit: LOT 964, OF WATERS EDGE FOUR, ACCORDING TO THE PLAT THEREOF, AS RECORDED IN PLAT BOOK 58, PAGE(S) 126 THROUGH 148, INCLUSIVE, OF THE PUBLIC RECORDS OF PASCO COUNTY, FLORIDA.

Property Address: 11340 BIDEFORD PLACE, NEW PORT RICHEY, FL 34654.  
 Any person claiming an interest in the surplus from the sale, if any, other than the property owner as of the date of the lis pendens, must file a claim within 60 days after the sale.

If you are a person with a disability who needs an accommodation in order to participate in this proceeding, you are entitled, at no cost to you, to the provision of certain assistance. Please contact: Public Information Dept., Pasco County Government Center, 7530 Little Rd. New Port Richey, FL 34654. Phone: 727.847.8110 (voice) in New Port Richey 352.521.4274, ext 8110 (voice) in Dade City Or 711 for the hearing impaired. Contact should be initiated at least seven days before the scheduled court appearance, or immediately upon receiving this notification if the time before the scheduled appearance is less than seven days.

The court does not provide transportation and cannot accommodate such requests. Persons with disabilities needing transportation to court should contact their local public transportation providers for information regarding transportation services.

Tania Marie Amar, Esq.  
 Florida Bar #: 84692  
**FRENKEL LAMBERT WEISS WEISMAN & GORDON, LLP**  
 Attorney for Plaintiff  
 One East Broward Blvd., Suite 1111  
 Fort Lauderdale, Fl 33301  
 Tel: (954) 522-3233 |  
 Fax: (954) 200-7770  
 DESIGNATED PRIMARY E-MAIL FOR SERVICE  
 PURSUANT TO  
 FL.A.R. JUD. ADMIN 2.516  
 flservice@flwlaw.com  
 04-062709-F00  
 Mar. 28; Apr. 4, 2014 14-01807P

SECOND INSERTION

NOTICE OF SALE IN THE CIRCUIT COURT OF THE SIXTH JUDICIAL CIRCUIT IN AND FOR PASCO COUNTY, FLORIDA  
**CASE NO.**  
**51-2010-CA-006631WS**  
**DIV. J3**

**U.S. BANK NATIONAL ASSOCIATION**  
**Plaintiff, v.**  
**NONALEA BLACK; MICHAEL R. BLACK; JOHN DOE AS UNKNOWN TENANT IN POSSESSION; JANE DOE AS UNKNOWN TENANT IN POSSESSION; AND ALL UNKNOWN PARTIES CLAIMING BY, THROUGH, UNDER OR AGAINST THE ABOVE NAMED DEFENDANT(S), WHO (IS/ARE) NOT KNOWN TO BE DEAD OR ALIVE, WHETHER SAID UNKNOWN PARTIES CLAIM AS HEIRS, DEVISEES, GRANTEEES, ASSIGNEES, LIENORS, CREDITORS, TRUSTEES, SPOUSES, OR OTHER CLAIMANTS;**  
**Defendants.**

Notice is hereby given that, pursuant to the Summary Final Judgment of Foreclosure entered on February 27, 2014, in this cause, in the Circuit Court of Pasco County, Florida, the clerk shall sell the property situated in Pasco County, Florida, described as:

PARCEL 917-A BEING A PORTION OF TRACT 917 OF THE UNRECORDED PLAT OF PARKWOOD ACRES SUBDIVISION, UNIT SEVEN, BEING FURTHER DESCRIBED AS FOLLOWS: COMMENCING AT THE SOUTHEAST CORNER OF SECTION 1, TOWNSHIP 25 SOUTH, RANGE 16, EAST, PASCO COUNTY, FLORIDA; GO THENCE NORTH 00°51'07" EAST ALONG THE EAST LINE OF SAID SECTION 1, A DISTANCE OF 137.88 FEET; THENCE WEST A DISTANCE OF 221.72 FEET; THENCE NORTH 89°17'40" WEST A DISTANCE OF 461.19 FEET; THENCE SOUTH 52°00'05" WEST A DISTANCE OF 14.59 FEET; THENCE NORTH 32°58'45"

WEST A DISTANCE OF 312.82 FEET TO THE POINT OF BEGINNING; THENCE SOUTH 57°01'15" WEST A DISTANCE OF 150.00 FEET; THENCE NORTH 32°58'45" WEST A DISTANCE OF 185.00 FEET; THENCE NORTH 57°01'05" EAST A DISTANCE OF 150.00 FEET; THENCE SOUTH 32°58'45" EAST 185.00 FEET TO THE POINT OF BEGINNING.

SUBJECT TO A 20 FEET WIDE INGRESS/EGRESS AND UTILITY EASEMENT ALONG THE SOUTHWEST LINE OF SAID PARCEL, WHICH SAID EASEMENT THE GRANTOR HEREIN SPECIFICALLY RESERVES.

TOGETHER WITH THAT CERTAIN 1999 KING MOBILE HOME, ID #N89325A/B.

a/k/a 12100 PARKWOOD ST, HUDSON, FL 34669

at public sale, to the highest and best bidder, for cash, online at www.pasco.realforeclose.com, on April 15, 2014 beginning at 11:00 AM.

If you are a person claiming a right to funds remaining after the sale, you must file a claim with the clerk no later than 60 days after the sale. If you fail to file a claim you will not be entitled to any remaining funds.

ANY PERSONS WITH A DISABILITY REQUIRING REASONABLE ACCOMMODATIONS SHOULD CALL NEW PORT RICHEY (813) 847-8110; DADE CITY (352) 521-4274 EXT 8110; TDD 1-800-955-8771 VIA FLORIDA RELAY SERVICE, NO LATER THAN SEVEN (7) DAYS PRIOR TO ANY PROCEEDING.

Dated at St. Petersburg, Florida, this 20th day of March 2014.  
 By: /s/ Angela L. Leiner, Esquire  
 Angela L. Leiner  
 FBN #85112

Douglas C. Zahm, P.A.  
 Designated Email Address:  
 efling@dczahm.com  
 12425 28th Street North, Suite 200  
 St. Petersburg, FL 33716  
 Telephone No. (727) 536-4911  
 Attorney for the Plaintiff  
 665110701  
 Mar. 28; Apr. 4, 2014 14-01828P

SECOND INSERTION

NOTICE OF FORECLOSURE SALE IN THE CIRCUIT COURT OF THE 6TH JUDICIAL CIRCUIT, IN AND FOR PASCO COUNTY, FLORIDA  
**Civil Action No.**  
**51-2010-CA-4660-ES**

**GMAC MORTGAGE, LLC,**  
**Plaintiff, v.**  
**ERNEST LOWELL, et al.,**  
**Defendant(s).**

NOTICE IS HEREBY GIVEN pursuant to a Uniform Final Judgment of Foreclosure dated March 12, 2014 and entered in Case No: 51-2010-CA-4660-ES of the Circuit Court of the 6th Judicial Circuit in and for Pasco County, Florida wherein Ocwen Loan Servicing, LLC is the Plaintiff, and Ernest Lowell, et al., is/are the Defendant(s), the clerk will sell to the highest and best bidder for cash, online at www.pasco.realforeclose.com @ 11:00 AM, on the 28th day of April, 2014, the following described property as set forth in said Final Judgment:

TRACT 1012, ANGUS VALLEY, UNIT 3A TRACT OF LAND LYING IN SECTION 2, TOWNSHIP 26 SOUTH, RANGE 19 EAST, PASCO COUNTY, FLORIDA: MORE PARTICULARLY DESCRIBED AS FOLLOWS: BEGIN AT THE SOUTHWEST CORNER OF THE STATED SECTION 2, THENCE RUN EAST (ASSUMED BEARING) ALONG THE SOUTH BOUNDARY OF THE STATED SECTION 2, A DISTANCE OF 4383.46 FEET; THENCE NORTH A DISTANCE OF 590.43 FEET; THENCE NORTH 00 DEGREES 11 MINUTES 18 SECONDS EAST, A DISTANCE OF 330.00 FEET FOR A POINT OF BEGINNING. THENCE CONTINUE WEST A DISTANCE OF 360.00 FEET; THENCE NORTH 00 DEGREES 11 MINUTES 18 SECONDS EAST A DISTANCE OF 150.00 FEET; THENCE EAST A DISTANCE OF 360.00 FEET; THENCE SOUTH 00 DEGREES 11 MINUTES 18 SECONDS WEST, A DISTANCE OF 150.00 FEET TO THE POINT OF BEGINNING. TOGETHER WITH THAT CERTAIN MANUFAC-

TURED HOME MORE SPECIFICALLY DESCRIBED AS: 1197 GENERAL/GENERAL (28 X 64) WITH SERIAL NUMBER GMGHA3149715787 A/B. Property Address: 6148 Wendell Drive, Wesley Chapel, Florida 33544

ANY PERSON CLAIMING AN INTEREST IN THE SURPLUS OF THE SALE, IF ANY, OTHER THAN THE PROPERTY OWNER, AS OF THE DATE OF THE LIS PENDENS, MUST FILE A CLAIM WITHIN SIXTY (60) DAYS AFTER THE SALE.

IF YOU ARE A PERSON WITH A DISABILITY WHO NEEDS ANY ACCOMMODATION IN ORDER TO PARTICIPATE IN THIS PROCEEDING, YOU ARE ENTITLED, AT NO COST TO YOU, TO THE PROVISION OF CERTAIN ASSISTANCE. PLEASE CONTACT THE PUBLIC INFORMATION DEPT., PASCO COUNTY GOVERNMENT CENTER, 7530 LITTLE RD., NEW PORT RICHEY, FL 34654; (727) 847-8110 (V) IN NEW PORT RICHEY; (352) 521-4274, EXT 8110 (V) IN DADE CITY, AT LEAST 7 DAYS BEFORE YOUR SCHEDULED COURT APPEARANCE, OR IMMEDIATELY UPON RECEIVING THIS NOTIFICATION IF THE TIME BEFORE THE SCHEDULED APPEARANCE IS LESS THAN 7 DAYS; IF YOU ARE HEARING IMPAIRED CALL 711. THE COURT DOES NOT PROVIDE TRANSPORTATION AND CANNOT ACCOMMODATE FOR THIS SERVICE. PERSONS WITH DISABILITIES NEEDING TRANSPORTATION TO COURT SHOULD CONTACT THEIR LOCAL PUBLIC TRANSPORTATION PROVIDERS FOR INFORMATION REGARDING TRANSPORTATION SERVICES.

This 24th day of March, 2014.  
 Respectfully submitted,  
 By: /s/ Kyle P. Peters  
 Kyle P. Peters  
 Florida Bar No. 91941  
 Primary: kpeters@bssf.com  
 Secondary: bssservice2@bssf.com  
 Busch, Slipakoff & Schuh, LLP  
 225 Water Street, Suite 1290  
 Jacksonville, Florida 32202-5175  
 Telephone No.: (770) 790-3550  
 Facsimile Phone No.: (770) 790-3520  
 Mar. 28; Apr. 4, 2014 14-01853P

SECOND INSERTION

AMENDED NOTICE OF FORECLOSURE SALE IN THE CIRCUIT COURT IN AND FOR PASCO COUNTY, FLORIDA CASE NO.:

51-2012-CA-006452-XXXX-ES JPMORGAN CHASE BANK, NATIONAL ASSOCIATION Plaintiff, vs. JULIE B. COHN; UNKNOWN SPOUSE OF JULIE B. COHN; UNKNOWN TENANT I; UNKNOWN TENANT II; COUNTRY WALK HOMEOWNERS' ASSOCIATION, INC.; BANK OF AMERICA, N.A., and any unknown heirs, devisees, grantees, creditors, and other unknown persons or unknown spouses claiming by, through and under any of the above-named Defendants, Defendants.

NOTICE is hereby given that the Clerk of the Circuit Court of Pasco County, Florida, will on the 10th day of April, 2014, at 11:00AM at www.pasco.realforeclose.com in accordance with Chapter 45 Florida Statutes, offer for sale and sell at public outcry to the highest and best bidder for cash, the following-described property situate in Pasco County, Florida:

LOT 100, COUNTRY WALK INCREMENT A-PHASE I, ACCORDING TO SUBDIVISION PLAT RECORDED IN PLAT BOOK 55, PAGE 18-22 OF THE PUBLIC RECORDS OF PASCO COUNTY, FLORIDA.

COUNTY, FLORIDA. pursuant to the Final Judgment entered in a case pending in said Court, the style of which is indicated above.

Any person or entity claiming an interest in the surplus, if any, resulting from the foreclosure sale, other than the property owner as of the date of the Lis Pendens, must file a claim on same with the Clerk of Court within 60 days after the foreclosure sale.

AMERICANS WITH DISABILITIES ACT. If you are a person with a disability who needs any accommodation in order to participate in this proceeding, you are entitled, at no cost to you, to the provision of certain assistance. Please contact the Human Rights Office, 400 S. Ft. Harrison Ave., Ste. 500 Clearwater, FL 33756, (727) 464-4880(V) at least 7 days before your scheduled court appearance, or immediately upon receiving this notification if the time before the scheduled appearance is less than 7 days; if you are hearing impaired call 711.

DATED this 19 day of March, 2014. Chris Bertels, Esquire Florida Bar No: 98267 BUTLER & HOSCH, P.A. 3185 South Conway Road, Suite E Orlando, Florida 32812 Telephone: (407) 381-5200 Fax: (407) 381-5577 cb98267@butlerandhosch.com FLPleadings@butlerandhosch.com B&H # 305945 Mar. 28; Apr. 4, 2014 14-01791P

SECOND INSERTION

NOTICE OF FORECLOSURE SALE IN THE CIRCUIT COURT OF THE SIXTH JUDICIAL CIRCUIT, IN AND FOR PASCO COUNTY, FLORIDA. CASE No.

51-2008-CA-004362-XXXX-ES DEUTSCHE BANK NATIONAL TRUST COMPANY, AS TRUSTEE FOR FFM LT TRUST 2006-FF13, MORTGAGE PASS-THROUGH CERTIFICATES, SERIES 2006-FF13, PLAINTIFF, VS. RONALD M. REED JR, ET AL. DEFENDANT(S).

NOTICE IS HEREBY GIVEN pursuant to the Final Judgment of Foreclosure dated March 5, 2014 in the above action, the Pasco County Clerk of Court will sell to the highest bidder for cash at Pasco, Florida, on April 23, 2014, at 11:00 AM, at www.pasco.realforeclose.com for the following described property:

LOT 30, BLOCK 6, SUNCOAST POINTE VILLAGE 1A AND 1B, ACCORDING TO THE PLAT THEREOF AS RECORDED IN THE PLAT BOOK 48, PAGES 68 THROUGH 71, INCLUSIVE, OF THE PUBLIC RECORDS OF PASCO COUNTY, FLORIDA.

Any person claiming an interest in the surplus from the sale, if any, other than the property owner as of the date of the lis pendens must file a claim within sixty (60) days after the sale. The Court, in its discretion, may enlarge the time

of the sale. Notice of the changed time of sale shall be published as provided herein.

If you are a person with a disability who needs any accommodation in order to participate in this proceeding, you are entitled, at no cost to you, to the provision of certain assistance. Please contact the Public Information Department at 727-847-8110 in New Port Richey or 352-521-4274, extension 8110 in Dade City or at Pasco County Government Center, 7530 Little Road, New Port Richey, FL 34654 at least 7 days before your scheduled court appearance, or immediately upon receiving this notification if the time before the scheduled appearance is less than 7 days; if you are hearing or voice impaired, call 711.

The court does not provide transportation and cannot accommodate such requests. Persons with disabilities needing transportation to court should contact their local public transportation providers for information regarding transportation services.

By: Jennifer Cecil, Esq. FBN 99718 Gladstone Law Group, P.A. Attorney for Plaintiff 1499 W. Palmetto Park Road, Suite 300 Boca Raton, FL 33486 Telephone #: 561-338-4101 Fax #: 561-338-4077 Email: eservice@lglaw.net Our Case #: 13-000089-FIH Mar. 28; Apr. 4, 2014 14-01804P

SECOND INSERTION

NOTICE OF SALE PURSUANT TO CHAPTER 45 IN THE CIRCUIT COURT OF THE 6TH JUDICIAL CIRCUIT, IN AND FOR PASCO COUNTY, FLORIDA CASE NO.: 2010-CA-009224-ES QUEEN'S PARK OVAL ASSET HOLDING TRUST, PLAINTIFF, VS. TROY RIVERA, ET. AL., DEFENDANTS.

NOTICE IS HEREBY GIVEN pursuant to a Final Judgment of Foreclosure dated February 26, 2014, and entered in Case No. 2010-CA-009224-ES of the Circuit Court of the 6th Judicial Circuit in and for Pasco County, Florida, wherein QUEEN'S PARK OVAL ASSET HOLDING TRUST, is Plaintiff, and TROY RIVERA, ET. AL., are Defendants, I will sell to the highest and best bidder for cash via online auction at www.pasco.realforeclose.com at 11:00 A.M. on the 15th day of April, 2014, the following described property as set forth in said Final Judgment, to wit:

The North 95.0 feet of the South 1359.0 feet of the East 155.0 feet of the West 185.0 feet of the West 1/2 of the West 1/2 of the Southwest 1/4 of Section 8, Township 24 South, Range 21 East, Pasco County, Florida. Property Address: 17224 Adela Street, Dade City, FL 33523 and all fixtures and personal property located therein or thereon, which are included as

security in Plaintiff's mortgage. Any person claiming an interest in the surplus funds from the sale, if any, other than the property owner as of the date of the lis pendens must file a claim within 60 days after the sale.

If you are a person with a disability who needs any accommodation in order to participate in this proceeding, you are entitled, at no cost to you, to the provision of certain assistance. Please contact the Public Information Dept., Pasco County Government Center, 7530 Little Rd., New Port Richey, FL 34654; (727) 847-8110 (V) in New Port Richey; (352) 521-4274, ext 8110 (V) in Dade City, at least 7 days before your scheduled court appearance, or immediately upon receiving this notification if the time before the scheduled appearance is less than 7 days; if you are hearing impaired call 711. The court does not provide transportation and cannot accommodate for this service. Persons with disabilities needing transportation to court should contact their local public transportation providers for information regarding transportation services.

Dated this 20th day of March, 2014. By: Marc Ruderman, Esq. FL Bar #899585 Clarfield, Okon, Salomone & Pincus, P.L. 500 S. Australian Avenue, Suite 730 West Palm Beach, FL 33401 (561) 713-1400 - pleadings@cosplaw.com Mar. 28; Apr. 4, 2014 14-01812P

SECOND INSERTION

NOTICE OF SALE IN THE CIRCUIT CIVIL COURT OF THE SIXTH JUDICIAL CIRCUIT OF FLORIDA, IN AND FOR PASCO COUNTY CIVIL DIVISION Case No. 51-2013-CA-000085ES Division J1

JPMORGAN CHASE BANK, NATIONAL ASSOCIATION Plaintiff, vs. JAMES ANDERSON, AS TRUSTEE OF THE D. MURPHY FAMILY TRUST DATED 4-11-2008, UNKNOWN BENEFICIARIES OF THE D. MURPHY FAMILY TRUST DATED 4-11-2008, CHAPEL PINES HOMEOWNERS ASSOCIATION, INC., DIANA MURPHY, AND UNKNOWN TENANTS/OWNERS, Defendants.

Notice is hereby given, pursuant to Final Judgment of Foreclosure for Plaintiff entered in this cause on February 18, 2014, in the Circuit Court of Pasco County, Florida, Paula O'Neil, Clerk of the Circuit Court, will sell the property situated in Pasco County, Florida described as:

LOT 42, BLOCK "K", CHAPEL PINES PHASE 2 AND 1C, AS PER PLAT THEREOF, RECORDED IN PLAT BOOK 45, PAGES 43 THROUGH 46, OF THE PUBLIC RECORDS OF PASCO COUNTY, FLORIDA.

and commonly known as: 30846 MIDTOWN COURT, WESLEY CHAPEL, FL 33544; including the building, appurtenances, and fixtures located therein, at public sale, to the highest and best bidder, for cash, www.pasco.

realforeclose.com, on April 21, 2014 at 11am.

Any persons claiming an interest in the surplus from the sale, if any, other than the property owner as of the date of the lis pendens must file a claim within 60 days after the sale.

If you are a person with a disability who needs any accommodation in order to participate in this proceeding, you are entitled, at no cost to you, to the provision of certain assistance. Please contact the Public Information Dept., Pasco County Government Center, 7530 Little Rd., New Port Richey, FL 34654; (727) 847-8110 (V) in New Port Richey; (352) 521-4274, ext 8110 (V) in Dade City, at least 7 days before your scheduled court appearance, or immediately upon receiving this notification if the time before the scheduled appearance is less than 7 days; if you are hearing impaired call 711. The court does not provide transportation and cannot accommodate for this service. Persons with disabilities needing transportation to court should contact their local public transportation providers for information regarding transportation services.

By: Edward B. Pritchard Attorney for Plaintiff Invoice to: Edward B. Pritchard (813) 229-0900 x1309 Kass Shuler, P.A. P.O. Box 800 Tampa, FL 33601-0800 ForeclosureService@kasslaw.com 200850/1120313/amm1 Mar. 28; Apr. 4, 2014 14-01780P

SECOND INSERTION

NOTICE OF SALE IN THE CIRCUIT CIVIL COURT OF THE SIXTH JUDICIAL CIRCUIT OF FLORIDA, IN AND FOR PASCO COUNTY CIVIL DIVISION Case No. 51-2013-CA-001266WS Division J3

JPMORGAN CHASE BANK, NATIONAL ASSOCIATION, SUCCESSOR IN INTEREST BY PURCHASE FROM THE FEDERAL DEPOSIT INSURANCE CORPORATION AS RECEIVER OF WASHINGTON MUTUAL BANK F/K/A WASHINGTON MUTUAL BANK, FA PLAINTIFF, vs. LORI L. STALLWOOD A/K/A LORI STALLWOOD, DAVID STALLWOOD, AND UNKNOWN TENANTS/OWNERS, Defendants.

Notice is hereby given, pursuant to Final Judgment of Foreclosure for Plaintiff entered in this cause on February 26, 2014, in the Circuit Court of Pasco County, Florida, Paula O'Neil, Clerk of the Circuit Court, will sell the property situated in Pasco County, Florida described as:

LOT 809, THE LAKES UNIT FOUR, ACCORDING TO THE PLAT THEREOF, AS RECORDED IN PLAT BOOK 18, PAGES 40 AND 41, OF THE PUBLIC RECORDS OF PASCO COUNTY, FLORIDA.

and commonly known as: 9109 DERBY LN, PORT RICHEY, FL 34668; including the building, appurtenances, and fixtures located therein, at public

sale, to the highest and best bidder, for cash, www.pasco.realforeclose.com, on April 21, 2014 at 11:00 AM.

Any persons claiming an interest in the surplus from the sale, if any, other than the property owner as of the date of the lis pendens must file a claim within 60 days after the sale.

If you are a person with a disability who needs any accommodation in order to participate in this proceeding, you are entitled, at no cost to you, to the provision of certain assistance. Please contact the Public Information Dept., Pasco County Government Center, 7530 Little Rd., New Port Richey, FL 34654; (727) 847-8110 (V) in New Port Richey; (352) 521-4274, ext 8110 (V) in Dade City, at least 7 days before your scheduled court appearance, or immediately upon receiving this notification if the time before the scheduled appearance is less than 7 days; if you are hearing impaired call 711. The court does not provide transportation and cannot accommodate for this service. Persons with disabilities needing transportation to court should contact their local public transportation providers for information regarding transportation services.

By: Edward B. Pritchard Attorney for Plaintiff Invoice to: Edward B. Pritchard (813) 229-0900 x1309 Kass Shuler, P.A. P.O. Box 800 Tampa, FL 33601-0800 ForeclosureService@kasslaw.com 327498/1120543/amm1 Mar. 28; Apr. 4, 2014 14-01781P

SECOND INSERTION

NOTICE OF SALE IN THE CIRCUIT CIVIL COURT OF THE SIXTH JUDICIAL CIRCUIT OF FLORIDA, IN AND FOR PASCO COUNTY CIVIL DIVISION Case No. 51-2013-CA-003416ES Division J1

JPMORGAN CHASE BANK, NATIONAL ASSOCIATION Plaintiff, vs. MICHAEL HIPP, SUSAN HIPP, THE BELMONT AT RYALS CHASE CONDOMINIUM ASSOCIATION, INC., AND UNKNOWN TENANTS/OWNERS, Defendants.

Notice is hereby given, pursuant to Final Judgment of Foreclosure for Plaintiff entered in this cause on February 18, 2014, in the Circuit Court of Pasco County, Florida, Paula O'Neil, Clerk of the Circuit Court, will sell the property situated in Pasco County, Florida described as:

CONDOMINIUM UNIT NO. 1-202, THE BELMONT AT RYALS CHASE, A CONDOMINIUM, ACCORDING TO THE DECLARATION OF CONDOMINIUM THEREOF, AS RECORDED IN OFFICIAL RECORDS BOOK 6561, AT PAGE 416, OF THE PUBLIC RECORDS OF PASCO COUNTY, FLORIDA.

and commonly known as: 36243 LAKE CHASE BLVD 202, ZEPHYRHILLS, FL 33541; including the building, appurtenances, and fixtures located therein, at public sale, to the highest and best bidder, for cash, www.pasco.

realforeclose.com, on April 21, 2014 at 11am.

Any persons claiming an interest in the surplus from the sale, if any, other than the property owner as of the date of the lis pendens must file a claim within 60 days after the sale.

If you are a person with a disability who needs any accommodation in order to participate in this proceeding, you are entitled, at no cost to you, to the provision of certain assistance. Please contact the Public Information Dept., Pasco County Government Center, 7530 Little Rd., New Port Richey, FL 34654; (727) 847-8110 (V) in New Port Richey; (352) 521-4274, ext 8110 (V) in Dade City, at least 7 days before your scheduled court appearance, or immediately upon receiving this notification if the time before the scheduled appearance is less than 7 days; if you are hearing impaired call 711. The court does not provide transportation and cannot accommodate for this service. Persons with disabilities needing transportation to court should contact their local public transportation providers for information regarding transportation services.

By: Edward B. Pritchard Attorney for Plaintiff Invoice to: Edward B. Pritchard (813) 229-0900 x1309 Kass Shuler, P.A. P.O. Box 800 Tampa, FL 33601-0800 ForeclosureService@kasslaw.com 200850/1334953/amm1 Mar. 28; Apr. 4, 2014 14-01783P

SECOND INSERTION

NOTICE OF RESCHEDULED SALE IN THE CIRCUIT COURT OF THE SIXTH JUDICIAL CIRCUIT IN AND FOR PASCO COUNTY, FLORIDA CIVIL ACTION CASE NO.:

51-2010-CA-004417-CAAX-WS DIVISION: 15

WELLS FARGO BANK, N.A., SUCCESSOR IN INTEREST TO WACHOVIA MORTGAGE, F.S.B. F/K/A WORLD SAVINGS BANK, F.S.B., Plaintiff, vs. RICHARD LEE LABRECHE, et al, Defendant(s).

NOTICE IS HEREBY GIVEN Pursuant to an Order Rescheduling Foreclosure Sale dated on or about February 19,2014, and entered in Case No. 51-2010-CA-004417-CAAX-WS of the Circuit Court of the Sixth Judicial Circuit in and for Pasco County, Florida in which Wells Fargo Bank, N.A., successor in interest to Wachovia Mortgage, F.S.B. f/k/a World Savings Bank, F.S.B., is the Plaintiff and Richard Lee Labreche, The Unknown Spouse of Richard Lee Labreche, Tenant #1 n/k/a Eric Gain, Tenant #2 n/k/a Violette Gain, are defendants, the Pasco County Clerk of the Circuit Court will sell to the highest and best bidder for cash in/on held online www.pasco.realforeclose.com: in Pasco County, Florida, Pasco County, Florida at 11:00AM on the 15th day of April 2014, the following described property as set forth in said Final Judgment of Foreclosure:

LOT 91, SHAMROCK HEIGHTS UNIT THREE, ACCORDING TO THE MAP OR PLAT THEREOF, AS RECORDED IN PLAT BOOK 8, PAGE 27, OF THE PUBLIC RECORDS OF PASCO COUNTY, FLORIDA.

FLORIDA. A/K/A 4606 NIMMER DRIVE, NEW PORT RICHEY, FL 34652

Any person claiming an interest in the surplus from the sale, if any, other than the property owner as of the date of the Lis Pendens must file a claim within 60 days after the sale.

If you are a person with a disability who needs an accommodation in order to participate in this proceeding, you are entitled, at no cost to you, to the provision of certain assistance. Please contact:

Public Information Dept., Pasco County Government Center 7530 Little Rd. New Port Richey, FL 34654 Phone: 727.847.8110 (voice) in New Port Richey 352.521.4274, ext 8110 (voice) in Dade City Or 711 for the hearing impaired

Contact should be initiated at least seven days before the scheduled court appearance, or immediately upon receiving this notification if the time before the scheduled appearance is less than seven days.

The court does not provide transportation and cannot accommodate such requests. Persons with disabilities needing transportation to court should contact their local public transportation providers for information regarding transportation services.

Dated in Hillsborough County, Florida this 19th day of March 2014. /s/ Erik Del'Etoile Erik Del'Etoile, Esq. FL Bar # 71675

Albertelli Law Attorney for Plaintiff P.O. Box 23028 Tampa, FL 33623 (813) 221-4743 JR- 10-43970 Mar. 28; Apr. 4, 2014 14-01785P

SECOND INSERTION

NOTICE OF RESCHEDULED SALE IN THE CIRCUIT COURT OF THE SIXTH JUDICIAL CIRCUIT IN AND FOR PASCO COUNTY, FLORIDA CIVIL ACTION CASE NO.:

51-2012-CA-001608-CAAX-WS DIVISION: 15

JPMORGAN CHASE BANK, NATIONAL ASSOCIATION, Plaintiff, vs. IRENE HALLISEY A/K/A IRENE T. HALLISEY, et al, Defendant(s).

NOTICE IS HEREBY GIVEN Pursuant to an Order Rescheduling Foreclosure Sale dated on or about February 19, 2014, and entered in Case No. 51-2012-CA-001608-CAAX-WS of the Circuit Court of the Sixth Judicial Circuit in and for Pasco County, Florida in which JPMorgan Chase Bank, National Association, is the Plaintiff and Irene Hallisey a/k/a Irene T. Hallisey, Kristine F. Hallisey a/k/a Kristine Hallisey a/k/a Kristine S. Hallisey, Mark Hallisey a/k/a Mark G. Hallisey, Natalie Porakischwili a/k/a Natalie G. Porakischwili, Bank of America, NA, Marina Thomure, are defendants, the Pasco County Clerk of the Circuit Court will sell to the highest and best bidder for cash in/on held online www.pasco.realforeclose.com: in Pasco County, Florida, Pasco County, Florida at 11:00AM on the 14th day of April, 2014, the following described property as set forth in said Final Judgment of Foreclosure:

LOT 87, COUNTRY CLUB ESTATES, UNIT 1-B, ACCORDING TO THE PLAT THEREOF AS RECORDED IN PLAT BOOK 8, PAGE(S) 148, OF THE PUBLIC RECORDS OF PASCO COUNTY, FLORIDA.

A/K/A 7310 WINDSOR ST, HUDSON, FL 34667-1861

Any person claiming an interest in the surplus from the sale, if any, other than the property owner as of the date of the Lis Pendens must file a claim within 60 days after the sale.

If you are a person with a disability who needs an accommodation in order to participate in this proceeding, you are entitled, at no cost to you, to the provision of certain assistance. Please contact:

Public Information Dept., Pasco County Government Center 7530 Little Rd. New Port Richey, FL 34654 Phone: 727.847.8110 (voice) in New Port Richey 352.521.4274, ext 8110 (voice) in Dade City Or 711 for the hearing impaired

Contact should be initiated at least seven days before the scheduled court appearance, or immediately upon receiving this notification if the time before the scheduled appearance is less than seven days.

The court does not provide transportation and cannot accommodate such requests. Persons with disabilities needing transportation to court should contact their local public transportation providers for information regarding transportation services.

Dated in Hillsborough County, Florida on this 19th day of March, 2014. /s/ Erik Del'Etoile Erik Del'Etoile, Esq. FL Bar # 71675

Albertelli Law Attorney for Plaintiff P.O. Box 23028 Tampa, FL 33623 (813) 221-4743 (813) 221-9171 facsimile eservice: servealaw@albertellilaw.com BM - 11-92946 Mar. 28; Apr. 4, 2014 14-01788P

SECOND INSERTION

NOTICE OF FORECLOSURE SALE IN THE CIRCUIT COURT OF THE SIXTH JUDICIAL CIRCUIT IN AND FOR PASCO COUNTY, FLORIDA CIVIL ACTION CASE NO.: 51-2013-CA-004962 WS DIVISION: J2

REGIONS BANK D/B/A REGIONS MORTGAGE, Plaintiff, vs. MARGARITA AUSTIN A/K/A MARGARET A. AUSTIN, et al, Defendant(s).

NOTICE IS HEREBY GIVEN pursuant to a Final Judgment of Mortgage Foreclosure dated March 12, 2014 and entered in Case No. 51-2013-CA-004962 WS of the Circuit Court of the Sixth Judicial Circuit in and for PASCO County, Florida wherein REGIONS BANK D/B/A REGIONS MORTGAGE is the Plaintiff and MARGARITA AUSTIN A/K/A MARGARET A. AUSTIN; SCOTT AUSTIN; LIONEL AUSTIN A/K/A LIONEL E. AUSTIN; ANY AND ALL UNKNOWN PARTIES CLAIMING BY, THROUGH, UNDER, AND AGAINST THE HEREIN NAMED INDIVIDUAL DEFENDANT(S) WHO ARE NOT KNOWN TO BE DEAD OR ALIVE, WHETHER SAID UNKNOWN PARTIES MAY CLAIM AN INTEREST AS SPOUSES, HEIRS, DEVISEES, GRANTEES, OR OTHER CLAIMANTS; TENANT #1 N/K/A STEVE BRATTON, TENANT #2 N/K/A DOLORES BRATTON, and TENANT #3 N/K/A JOEY BROWN are the Defendants, The Clerk will sell to the highest and best bidder for cash at WWW.PASCO.REALFORECLOSE.COM IN ACCORDANCE WITH CHAPTER 45 FLORIDA STATUTES at 11:00AM, on 04/24/2014, the following described property as set forth in said Final Judgment:

LOT 244, HOLIDAY LAKE ESTATES - UNIT FIVE, ACCORDING TO THE MAP OR PLAT THEREOF RECORDED IN PLAT BOOK 9, PAGE 69, OF THE PUBLIC RECORDS OF PASCO COUNTY, FLORIDA.

A/K/A 3700 DICKENS DRIVE, HOLIDAY, FL 34691

Any person claiming an interest in the surplus from the sale, if any, other than the property owner as of the date of the Lis Pendens must file a claim within sixty (60) days after the sale.

\*\*See Americans with Disabilities Act

"If you are a person with a disability who needs an accommodation in order to participate in this proceeding, you are entitled, at no cost to you, to the provision of certain assistance. Please contact:

Public Information Dept., Pasco County Government Center 7530 Little Rd. New Port Richey, FL 34654 Phone: 727.847.8110 (voice) in New Port Richey 352.521.4274, ext 8110 (voice) in Dade City Or 711 for the hearing impaired

Contact should be initiated at least seven days before the scheduled court appearance, or immediately upon receiving this notification if the time before the scheduled appearance is less than seven days."

By: Shaina Druker Florida Bar No. 0100213 Ronald R Wolfe & Associates, P.L. P.O. Box 25018 Tampa, Florida 33622-5018 (813) 251-4766 (813) 251-1541 Fax F13004280 Mar. 28; Apr. 4, 2014 14-01794P

SECOND INSERTION

NOTICE OF SALE PURSUANT TO CHAPTER 45 IN THE CIRCUIT COURT OF THE SIXTH JUDICIAL CIRCUIT IN AND FOR PASCO COUNTY, FLORIDA CIVIL ACTION

**CASE NO.: 51-2009-CA-006784-CAAX-WS NATIONSTAR MORTGAGE LLC, Plaintiff, vs. GIBBS, STEPHEN et al, Defendant(s).**  
NOTICE IS HEREBY GIVEN Pursuant to a Final Judgment of Foreclosure dated February 26, 2014, and entered in Case No. 51-2009-CA-006784-CAAX-WS of the Circuit Court of the Sixth Judicial Circuit in and for Pasco County, Florida in which Nacionstar Mortgage LLC, is the Plaintiff and Beacon Woods Civic Association, Inc., Doris J. Gibbs, Mortgage Electronic Registration Systems Incorporated, as a Nominee for Citibank N.A., Stephen L. Gibbs, are defendants, the Pasco County Clerk of the Circuit Court will sell to the highest and best bidder for cash held online www.pasco.realforeclose.com in Pasco County, Florida, Pasco

County, Florida at 11:00AM on the 17th day of April 2014, the following described property as set forth in said Final Judgment of Foreclosure: LOT 862, BEACON WOODS, VILLAGE 9-D, ACCORDING TO THE PLAT THEREOF AS RECORDED IN PLAT BOOK 14, PAGE(S) 62 AND 63, OF THE PUBLIC RECORDS OF PASCO COUNTY, FLORIDA. 12850 IRONWOOD CIR HUDSON, FLORIDA 34667-2351  
Any person claiming an interest in the surplus from the sale, if any, other than the property owner as of the date of the Lis Pendens must file a claim within 60 days after the sale.  
If you are a person with a disability who needs an accommodation in order to participate in this proceeding, you are entitled, at no cost to you, to the provision of certain assistance. Please contact:  
Public Information Dept., Pasco County Government Center 7530 Little Rd. New Port Richey, FL 34654 Phone: 727.847.8110 (voice) in New Port Richey 352.521.4274, ext 8110 (voice) in Dade City Or 711 for the hearing

impaired  
Contact should be initiated at least seven days before the scheduled court appearance, or immediately upon receiving this notification if the time before the scheduled appearance is less than seven days.  
The court does not provide transportation and cannot accommodate such requests. Persons with disabilities needing transportation to court should contact their local public transportation providers for information regarding transportation services.  
Dated in Hillsborough County, Florida, this 25th day of March, 2014  
/s/ Erik Del'Etoile  
Erik Del'Etoile, Esq.  
FL Bar # 71675  
Albertelli Law  
Attorney for Plaintiff  
P.O. Box 23028  
Tampa, FL 33623  
(813) 221-4743  
(813) 221-9171 facsimile  
eService: servealaw@albertellilaw.com  
JR- 12-109625  
Mar. 28; Apr. 4, 2014 14-01916P

SECOND INSERTION

NOTICE OF SALE PURSUANT TO CHAPTER 45 IN THE CIRCUIT COURT OF THE 6TH JUDICIAL CIRCUIT, IN AND FOR PASCO COUNTY, FLORIDA.

**CASE NO.: 51-2010-CA-000634 WS WELLS FARGO BANK, N.A., AS TRUSTEE FOR THE CERTIFICATEHOLDERS OF SOUNDVIEW HOME LOAN TRUST 2007-OPT1, ASSET-BACKED CERTIFICATES, SERIES 2007-OPT1, Plaintiff, vs. DEBRA A. KORES, Jeffery M. Kores, James H. Marlow, Defendants,**  
NOTICE IS HEREBY GIVEN pursuant to a Final Judgment of Foreclosure dated January 16, 2014, and entered in Case No. 51-2010-CA-000634 WS of the Circuit Court of the 6th Judicial Circuit in and for Pasco County, Florida, wherein WELLS FARGO BANK, N.A., AS TRUSTEE FOR THE CERTIFICATEHOLDERS OF SOUNDVIEW HOME LOAN TRUST 2007-OPT1, ASSET-BACKED CERTIFICATES,

SERIES 2007-OPT1, is Plaintiff, and DEBRA A. KORES, Jeffery M. Kores, James H. Marlow, are Defendants, I will sell to the highest and best bidder for cash via online auction at www.pasco.realforeclose.com at 11:00 A.M. on the 16th day of April, 2014, the following described property as set forth in said Final Judgment, to wit:  
Lot 132, GOLDEN ACRES UNIT 12, according to the Plat thereof, as recorded in Plat Book 16, page 96-100 of the Public Records of Pasco County, Florida  
Property Address: 10140 Casey Drive, New Port Richey, FL 34654  
Any person claiming an interest in the surplus funds from the sale, if any, other than the property owner as of the date of the lis pendens must file a claim within 60 days after the sale.  
If you are a person with a disability who needs any accommodation in order to participate in this proceeding, you are entitled, at no cost to you, to the provision of cer-

tain assistance. Please contact the Public Information Dept., Pasco County Government Center, 7530 Little Rd., New Port Richey, FL 34654; (727) 847-8110 (V) in New Port Richey; (352) 521-4274, ext 8110 (V) in Dade City, at least 7 days before your scheduled court appearance, or immediately upon receiving this notification if the time before the scheduled appearance is less than 7 days; if you are hearing impaired call 711. The court does not provide transportation and cannot accommodate for this service. Persons with disabilities needing transportation to court should contact their local public transportation providers for information regarding transportation services.  
Dated this 25th day of March, 2014.  
By: Jonathan Giddens  
FL Bar No. 0840041  
Clarfield, Okon, Salomone & Pincus, P.L.  
500 S. Australian Avenue, Suite 730  
West Palm Beach, FL 33401  
(561) 713-1400 - pleadings@cosplaw.com  
Mar. 28; Apr. 4, 2014 14-01917P

SECOND INSERTION

NOTICE OF SALE IN THE CIRCUIT CIVIL COURT OF THE SIXTH JUDICIAL CIRCUIT OF FLORIDA, IN AND FOR PASCO COUNTY

CIVIL DIVISION  
**Case No. 51-2013-CA-001929WS Division J3 JPMORGAN CHASE BANK, NATIONAL ASSOCIATION Plaintiff, vs. JULIAN MAMO A/K/A JULIAN ROSE MAMO A/K/A JULIAN ROSE PERKINS, GUARDIAN OF ERICA JOLIE MAMO, A MINOR, JULIAN MAMO A/K/A JULIAN ROSE MAMO A/K/A JULIAN ROSE PERKINS, PASCO COUNTY, FLORIDA, AND UNKNOWN TENANTS/OWNERS, Defendants.**  
Notice is hereby given, pursuant to Final Judgment of Foreclosure for Plaintiff entered in this cause on February 26, 2014, in the Circuit Court of Pasco County, Florida, Paula O'Neil, Clerk of the Circuit Court, will sell the property situated in Pasco County, Florida described as:  
TRACT 180 OF THE UNRECORDED PLAT OF LAKE WOOD ACRES, UNIT 2, PASCO COUNTY, FLORIDA, BEING FURTHER DESCRIBED AS FOLLOWS:  
COMMENCING AT THE NORTHWEST CORNER OF SECTION 5, TOWNSHIP 25 SOUTH, RANGE 17 EAST, PASCO COUNTY, FLORIDA, GO THENCE SOUTH 00° 21' 38" WEST ALONG THE WEST LINE OF SAID SECTION 5, A DISTANCE OF 569.50 FEET; THENCE SOUTH 89° 23' 40"

EAST. A DISTANCE OF 379.74 FEET; THENCE SOUTH 33° 30' 20" WEST, A DISTANCE OF 354.88 FEET; THENCE SOUTH 56° 29' 40" EAST, A DISTANCE OF 2005.00 FEET TO THE POINT OF BEGINNING; CONTINUE THENCE SOUTH 56° 29' 40" EAST, A DISTANCE OF 765.04 FEET; THENCE SOUTH 55° 00' 40" WEST, A DISTANCE OF 354.70 FEET; THENCE NORTH 56° 29' 40" WEST, A DISTANCE OF 635.00 FEET; THENCE NORTH 33° 30' 20" EAST, A DISTANCE OF 330.00 FEET TO THE POINT OF BEGINNING.  
LESS THE FOLLOWING DESCRIBED PORTION:  
COMMENCE AT THE NORTHWEST CORNER OF SECTION 5, TOWNSHIP 25 SOUTH, RANGE 17 EAST, PASCO COUNTY, FLORIDA; THENCE RUN SOUTH 00° 21' 38" WEST 569.50 FEET ALONG THE WEST LINE OF SAID SECTION 5; THENCE SOUTH 89° 23' 40" EAST, 379.74 FEET; THENCE SOUTH 33° 30' 20" WEST 354.88 FEET; THENCE SOUTH 56° 29' 40" EAST, 2005.00 FEET TO A POINT OF BEGINNING; THENCE CONTINUE SOUTH 56° 29' 40" EAST 380.00 FEET; THENCE SOUTH 33° 30' 20" WEST, 125.00 FEET; THENCE NORTH 56° 29' 40" WEST, 380.00 FEET; THENCE NORTH 33° 30' 20" EAST, 125.00 FEET TO THE POINT OF BEGINNING.  
and commonly known as: 12538 CHOCTAW TRAIL, HUDSON, FL

34669; including the building, appurtenances, and fixtures located therein, at public sale, to the highest and best bidder, for cash, www.pasco.realforeclose.com, on April 21, 2014 at 11:00 AM.  
Any persons claiming an interest in the surplus from the sale, if any, other than the property owner as of the date of the lis pendens must file a claim within 60 days after the sale.  
If you are a person with a disability who needs any accommodation in order to participate in this proceeding, you are entitled, at no cost to you, to the provision of certain assistance. Please contact the Public Information Dept., Pasco County Government Center, 7530 Little Rd., New Port Richey, FL 34654; (727) 847-8110 (V) in New Port Richey; (352) 521-4274, ext 8110 (V) in Dade City, at least 7 days before your scheduled court appearance, or immediately upon receiving this notification if the time before the scheduled appearance is less than 7 days; if you are hearing impaired call 711. The court does not provide transportation and cannot accommodate for this service. Persons with disabilities needing transportation to court should contact their local public transportation providers for information regarding transportation services.  
By: Edward B. Pritchard  
Attorney for Plaintiff  
Invoice to:  
Edward B. Pritchard  
(813) 229-0900 x1309  
Kass Shuler, P.A.  
P.O. Box 800  
Tampa, FL 33601-0800  
ForeclosureService@kasslaw.com  
200850/1126338/amm1  
Mar. 28; Apr. 4, 2014 14-01782P

NOTICE OF SALE PURSUANT TO CHAPTER 45 IN THE CIRCUIT COURT OF THE SIXTH JUDICIAL CIRCUIT IN AND FOR PASCO COUNTY, FLORIDA CIVIL ACTION

**CASE NO.: 51-2013-CA-000495-CAAX-ES WELLS FARGO BANK, N.A., Plaintiff, vs. CARPIO, GUILLERMO G. et al, Defendant(s).**  
NOTICE IS HEREBY GIVEN Pursuant to a Final Judgment of Foreclosure dated January 15, 2014, and entered in Case No. 51-2013-CA-000495-CAAX-ES of the Circuit Court of the Sixth Judicial Circuit in and for Pasco County, Florida in which Wells Fargo Bank, N.A. is the Plaintiff and Guillermo G. Carpio, The Unknown Spouse of Guillermo G. Carpio also known as Olwyn Aipperspach, are defendants, the Pasco County Clerk of the Circuit Court will sell to the highest and best bidder for cash in/on held online www.pasco.realforeclose.com: in Pasco County, Florida at 11:00AM on the 15th day of April, 2014, the following described property as set forth in said Final Judgment of Foreclosure:  
A PORTION OF SECTION 16, TOWNSHIP 26 SOUTH, RANGE 19 EAST, PASCO COUNTY, FLORIDA, BEING FURTHER DESCRIBED AS FOLLOWS: COMMENCE AT THE SOUTHEAST CORNER OF SAID SECTION 16; THENCE RUN ALONG THE EAST LINE OF SAID SECTION 16, NORTH 00 DEGREES 31 MINUTES 24 SECONDS EAST, 2,637.26 FEET; THENCE DEPARTING THE EAST BOUND-

ARY LINE OF SAID SECTION 16, NORTH 89 DEGREES 24 MINUTES 59 SECONDS WEST, 695.26 FEET TO THE EASTERLY RIGHT-OF-WAY LINE OF OAKS BLVD; THENCE ALONG THE ARC OF A CURVE TO THE LEFT 30.06 FEET, HAVING A RADIUS OF 4,492.16 FEET, A CENTRAL ANGLE OF 00 DEGREES 23 MINUTES 00 SECONDS, AND A CHORD WHICH BEARS NORTH 4 DEGREES 13 MINUTES 51 SECONDS EAST; 30.06 FEET TO THE POINT OF BEGINNING; THENCE CONTINUE ALONG SAID RIGHT-OF-WAY LINE, ALONG THE ARC OF A CURVE TO THE LEFT 345.89 FEET, HAVING A RADIUS OF 4,492.16 FEET, A CENTRAL ANGLE OF 04 DEGREES 24 MINUTES 42 SECONDS, AND A CHORD WHICH BEARS NORTH 01 DEGREES 50 MINUTES 00 SECONDS EAST, 345.80 FEET; THENCE DEPARTING THE EASTERLY RIGHT-OF-WAY LINE, SOUTH 89 DEGREES 24 MINUTES 38 SECONDS EAST, 367.28 FEET; THENCE SOUTH 00 DEGREES 31 MINUTES 16 SECONDS WEST, 345.70 FEET; THENCE NORTH 89 DEGREES 24 MINUTES 59 SECONDS WEST, 375.20 FEET TO THE AFORESAID EASTERLY RIGHT-OF-WAY LINE OF OAKS BLVD. AND THE POINT OF BEGINNING  
24551 OAKS BLVD, LAND O LAKES, FL 34639-5567  
Any person claiming an interest in the

surplus from the sale, if any, other than the property owner as of the date of the Lis Pendens must file a claim within 60 days after the sale.  
If you are a person with a disability who needs an accommodation in order to participate in this proceeding, you are entitled, at no cost to you, to the provision of certain assistance. Please contact:  
Public Information Dept., Pasco County Government Center 7530 Little Rd. New Port Richey, FL 34654 Phone: 727.847.8110 (voice) in New Port Richey 352.521.4274, ext 8110 (voice) in Dade City Or 711 for the hearing impaired  
Contact should be initiated at least seven days before the scheduled court appearance, or immediately upon receiving this notification if the time before the scheduled appearance is less than seven days.  
The court does not provide transportation and cannot accommodate such requests. Persons with disabilities needing transportation to court should contact their local public transportation providers for information regarding transportation services.  
Dated in Hillsborough County, Florida, this 19th day of March, 2014  
/s/ Erik Del'Etoile  
Erik Del'Etoile, Esq.  
FL Bar # 71675  
Albertelli Law  
Attorney for Plaintiff  
P.O. Box 23028  
Tampa, FL 33623  
(813) 221-4743  
(813) 221-9171 facsimile  
eService: servealaw@albertellilaw.com  
BM - 007342F01  
Mar. 28; Apr. 4, 2014 14-01789P

SECOND INSERTION

RE-NOTICE OF FORECLOSURE SALE IN THE CIRCUIT COURT OF THE 6TH JUDICIAL CIRCUIT, IN AND FOR PASCO COUNTY, FLORIDA CIVIL DIVISION:

**CASE NO.: 51-2012-CA-005213-XXXX-WS JPMORGAN CHASE BANK, NATIONAL ASSOCIATION, SUCCESSOR IN INTEREST BY PURCHASE FROM THE FDIC AS RECEIVER OF WASHINGTON MUTUAL BANK, Plaintiff, vs. DANIELO BOSKOVICH; BEAR CREEK ESTATES HOMEOWNERS ASSOCIATION, INC.; MARY BOSKOVICH; UNKNOWN TENANT IN POSSESSION OF THE SUBJECT PROPERTY, Defendants.**  
NOTICE IS HEREBY GIVEN pursuant to an Order Resetting Foreclosure Sale dated the 19th day of December, 2013, and entered in Case No. 51-2012-CA-005213-XXXX-WS, of the Circuit Court of the 6TH Judicial Circuit in and for Pasco County, Florida, wherein JPMORGAN CHASE BANK, NATIONAL ASSOCIATION, SUCCESSOR IN INTEREST BY PURCHASE FROM THE FDIC AS RECEIVER OF WASHINGTON MUTUAL BANK is the Plaintiff and DANIELO BOSKOVICH; BEAR CREEK ESTATES HOMEOWNERS ASSOCIATION, INC.; MARY BOSKOVICH; UNKNOWN TENANT IN POSSESSION OF THE SUBJECT PROPERTY are defendants. The Clerk of this Court shall sell to the highest and best bidder for cash, on the 17th day of April, 2014, at 11:00

AM on Pasco County's Public Auction website: www.pasco.realforeclose.com, pursuant to judgment or order of the Court, in accordance with Chapter 45, Florida Statutes, the following described property as set forth in said Final Judgment, to wit:  
SEE EXHIBIT A.  
EXHIBIT A  
LEGAL DESCRIPTION  
The land referred to in this policy is situated in the State of FL, County of PASCO, City of NEW PORT RICHEY and described as follows:  
Tract 130 of unrecorded plat of Bear Creek Estates, Unit Two, Pasco County, Florida, lying in Section 7, Township 25 South, Range 17 East, being more fully described as follows: Commence at the Southwest corner of said Section 8; thence run South 89 deg 28'57" East, along the South line of said Section 8, 1000.0 feet; thence due North 2680.29 feet; thence due West 2931.71 feet to the point of beginning; thence South 17 deg 49' 30" East, 460.71 feet; thence 94.82 feet along the arc of a curve to the left having a radius of 424.49 feet and a chord of 94.62 feet which bears South 65 deg 46'33" West; thence North 30 deg 37'24" West, 558.96 feet; thence South 89 deg 06' 16" East, 230.0 feet to the point of beginning, the Southeasterly 25.0 feet thereof being reserved as road right-of-way for ingress and egress.  
APN 072517052000001300 WITH THE APPURTENANCES THERETO.  
APN: 072517052000001300

ANY PERSON CLAIMING AN INTEREST IN THE SURPLUS FROM THE SALE, IF ANY, OTHER THAN THE PROPERTY OWNER AS OF THE DATE OF THE LIS PENDENS MUST FILE A CLAIM WITHIN 60 DAYS AFTER THE SALE.  
If you are a person with a disability who needs any accommodation in order to participate in this proceeding, you are entitled, at no cost to you, to the provision of certain assistance. Please contact the Public Information Dept., Pasco County Government Center, 7530 Little Rd., New Port Richey, FL 34654; (727) 847-8110 (V) in New Port Richey; (352) 521-4274, ext 8110 (V) in Dade City, at least 7 days before your scheduled court appearance, or immediately upon receiving this notification if the time before the scheduled appearance is less than 7 days; if you are hearing impaired call 711. The court does not provide transportation and cannot accommodate for this service. Persons with disabilities needing transportation to court should contact their local public transportation providers for information regarding transportation services.  
Dated this 19 day of March, 2014.  
By: Jennifer Nicole Tarquinio  
Bar #99192  
Submitted by:  
Choice Legal Group, P.A.  
1800 NW 49th Street, Suite 120  
Fort Lauderdale, Florida 33309  
Telephone: (954) 453-0365  
Facsimile: (954) 771-6052  
Toll Free: 1-800-441-2438  
DESIGNATED PRIMARY E-MAIL FOR SERVICE PURSUANT TO FLA. R. JUD. ADMIN 2.516  
eservice@clegalgroup.com  
11-16440  
Mar. 28; Apr. 4, 2014 14-01799P

NOTICE OF SALE IN THE CIRCUIT COURT OF THE 6TH JUDICIAL CIRCUIT IN AND FOR PASCO COUNTY, FLORIDA, CIVIL ACTION

**CASE NO.: 51-2012-CA-003092-WS WELLS FARGO BANK, N.A., AS TRUSTEE FOR OPTION ONE MORTGAGE LOAN TRUST 2006-1, ASSET-BACKED CERTIFICATES, SERIES 2006-1, Plaintiff vs. CHARLOTTE RANCE A/K/A CHARLOTTE H. RANCE, et al. Defendant(s)**  
Notice is hereby given that, pursuant to an Order Rescheduling Foreclosure Sale, dated February 19, 2014, entered in Civil Case Number 51-2012-CA-003092-WS, in the Circuit Court for Pasco County, Florida, wherein WELLS FARGO BANK, N.A., AS TRUSTEE FOR OPTION ONE MORTGAGE LOAN TRUST 2006-1, ASSET-BACKED CERTIFICATES, SERIES 2006-1 is the Plaintiff, and CHARLOTTE RANCE A/K/A CHARLOTTE H. RANCE, et al., are the Defendants, Pasco County Clerk of Court - East Side will sell the property situated in Pasco County, Florida, described as:  
LOT 430, PARK LANE ESTATES UNIT FIVE-A, ACCORDING TO THE MAP OR PLAT THEREOF, AS RECORDED IN PLAT BOOK 18, PAGE 149 AND 150, OF THE PUBLIC RECORDS OF PASCO COUNTY, FLORIDA.  
at public sale, to the highest and best bidder, for cash, at www.pasco.realforeclose.com at 11:00 AM, on the 24th day of April, 2014. Any person claiming an interest in the surplus from the sale, if any, other than the property owner as of the date of the lis pendens must file a claim within 60 days after the sale.  
If you are a person with a disability who needs any accommodation in order to participate in this proceeding,

you are entitled, at no cost to you to the provision of certain assistance. Within two (2) working days of your receipt of this (describe notice/order) please contact the Public Information Dept., Pasco County Government Center, 7530 Little Rd., New Port Richey, FL 34654; (727) 847-8110 (V) in New Port Richey; (352) 521-4274, ext. 8110 (V) in Dade City; via 1-800-955-8771 if you are hearing impaired. The court does not provide transportation and cannot accommodate for this service. Persons with disabilities needing transportation to court should contact their local public transportation providers for information regarding disabled transportation services.  
Si ou se yon moun ki gen yon andikap ki bezwen aranjman nenpòt nan lòd yo patisipe nan sa a pwosè dapèl, ou gen dwa, san sa pa kouste ou nan dispozisyon pou asistans a sèten. Nan de (2) k ap travay jou apre yo resevwa ou nan sa a (deklari avè / lòd) tanpri kontakte Enfòmasyon Piblik la Dept, Gouvènman Konte Pasco Center, 7530 Little Rd, New Port Richey, FL 34654.; (727) 847-8110 (V) nan New Port Richey; (352) 521-4274, ext. 8110 (V) nan Dade City; via 1-800-955-8771 si ou genyen pwoblèm pou tande. Tribinal la pa bay transpò epi yo pa kapab akomodè pou sèvis sa a. Moun ki andikape ki bezwen transpò nan tribinal la ta dwe kontakte founisè lokal transpò yo piblik pou enfòmasyon konsènan sèvis transpò ki andikape.  
Si vous êtes une personne handicapée qui a besoin d'une adaptation pour pouvoir participer à cette instance, vous avez le droit, sans frais pour vous à la fourniture d'une assistance certain. Dans les deux (2) jours ouvrables suivant la réception de la présente (décrire avis / ordre) s'il vous plaît contacter le Département de l'information publique, Pasco County Government Center, 7530 Rd Little,

New Port Richey, FL 34654., (727) 847-8110 (V) à New Port Richey, (352) 521-4274, ext. 8110 (V) à Dade City, via 1-800-955-8771 si vous êtes sourd ou malentendant. Le tribunal n'a pas assurer le transport et ne peut pas s'accommoder de ce service. Les personnes handicapées ont besoin transport vers le tribunal doit communiquer avec leurs fournisseurs locaux de transport en commun des informations concernant les services de transport à mobilité réduite.  
Si usted es una persona con una discapacidad que necesita cualquier acomodación para poder participar en este procedimiento, usted tiene derecho, sin costo alguno para usted a la prestación de asistencia determinada. Dentro de los dos (2) días hábiles siguientes a la recepción de esta (describir aviso / order) por favor póngase en contacto con el Departamento de Información Pública, Pasco County Government Center, 7530 Rd Little, New Port Richey, FL 34654., (727) 847-8110 (V) en New Port Richey, (352) 521-4274, ext. 8110 (V) en Dade City, a través 1-800-955-8771 si tiene problemas de audición. El tribunal no proporciona el transporte y no se puede acomodar para este servicio. Las personas con discapacidad que necesitan transporte a los tribunales deberán contactar a sus proveedores locales de transporte público para obtener información sobre los servicios de transporte con discapacidad.  
Dated: March 20, 2014  
By: S/Josh Arthur  
Josh Arthur, Esquire  
(FBN 95506)  
FLORIDA FORECLOSURE ATTORNEYS, PLLC  
4855 Technology Way, Suite 500  
Boca Raton, FL 33431  
(727) 446-4826  
emailservice@fapllc.com  
Our File No: CA12-00690 /OA  
Mar. 28; Apr. 4, 2014 14-01806P

## SECOND INSERTION

NOTICE OF RESCHEDULED FORECLOSURE SALE IN THE CIRCUIT COURT OF THE SIXTH JUDICIAL CIRCUIT IN AND FOR PASCO COUNTY, FLORIDA CIVIL ACTION

**CASE NO.:**  
**51-2012-CA-007029ES**  
**DIVISION: J1**

**JPMORGAN CHASE BANK, NATIONAL ASSOCIATION, Plaintiff, vs.**  
**THOMAS VALENTINO, et al, Defendant(s).**

NOTICE IS HEREBY GIVEN pursuant to an Order Rescheduling Foreclosure Sale dated March 7, 2014 and entered in Case NO. 51-2012-CA-007029ES of the Circuit Court of the SIXTH Judicial Circuit in and for PASCO County, Florida wherein JPMORGAN CHASE BANK, NATIONAL ASSOCIATION, is the Plaintiff and THOMAS VALENTINO; CHERYL VALENTINO; SABLE RIDGE HOMEOWNERS' ASSOCIATION, INC.; TENANT #1 N/K/A MATT GOLDBERG are the Defendants, The Clerk will sell to the highest and best bidder for cash at WWW.PASCO.REALFORECLOSE.COM IN ACCORDANCE WITH CHAPTER 45 FLORIDA STATUTES at 11:00AM, on 04/16/2014, the following described property as set forth in said Final Judgment

LOT 169, HERON POINT AT SABLE RIDGE PHASE 1D, ACCORDING TO MAP OR PLAT THEREOF, AS RECORDED IN PLAT BOOK 34, PAGES

139 THROUGH 141; OF THE PUBLIC RECORDS OF PASCO COUNTY, FLORIDA. A/K/A 4147 WHITTNER DRIVE, LAND O LAKES, FL 34639

Any person claiming an interest in the surplus from the sale, if any, other than the property owner as of the date of the Lis Pendens must file a claim within sixty (60) days after the sale.

\*\*See Americans with Disabilities Act

"If you are a person with a disability who needs an accommodation in order to participate in this proceeding, you are entitled, at no cost to you, to the provision of certain assistance. Please contact:

Public Information Dept., Pasco County Government Center 7530 Little Rd. New Port Richey, FL 34654 Phone: 727.847.8110 (voice) in New Port Richey 352.521.4274, ext 8110 (voice) in Dade City Or 711 for the hearing impaired

Contact should be initiated at least seven days before the scheduled court appearance, or immediately upon receiving this notification if the time before the scheduled appearance is less than seven days."

By: Kimberly L. Garno  
Florida Bar No. 84538  
Ronald R Wolfe & Associates, P.L.  
P.O. Box 25018  
Tampa, Florida 33622-5018  
(813) 251-4766  
(813) 251-1541 Fax  
F12009724  
Mar. 28; Apr. 4, 2014 14-01798P

## SECOND INSERTION

NOTICE OF SALE PURSUANT TO CHAPTER 45 IN THE CIRCUIT COURT OF THE 6TH JUDICIAL CIRCUIT IN AND FOR PASCO COUNTY, FLORIDA **CASE NO.:** 51-2010-CA-006853-ES **BANK OF AMERICA, NATIONAL ASSOCIATION, Plaintiff, vs.**

**LEOPOLDO RODRIGUEZ, et al., Defendants,**

NOTICE IS HEREBY GIVEN pursuant to a Final Judgment of Foreclosure dated January 22, 2014, and to an order granting motion to reset foreclosure sale, docketed March 7, 2014, and entered in Case No. 51-2010-CA-006853-ES of the Circuit Court of the 6th Judicial Circuit in and for Pasco County, Florida, wherein BANK OF AMERICA, NATIONAL ASSOCIATION, is Plaintiff, and LEOPOLDO RODRIGUEZ, et al., are Defendants, I will sell to the highest and best bidder for cash via online auction at www.pasco.realforeclose.com at 11:00 A.M. on the 15th day of April, 2014, the following described property as set forth in said Final Judgment, to wit:

LOT 9, BLOCK 2, BALLNTRAE VILLAGE 2A, ACCORDING TO THE MAP OR PLAT THEREOF AS RECORDED IN PLAT BOOK 49, PAGES 33 THROUGH 45, OF THE PUBLIC RECORDS OF PASCO COUNTY, FLORIDA. Property Address: 2930 Downan Point Drive, Land O'Lakes, FL 34638 and all fixtures and personal

property located therein or thereon, which are included as security in Plaintiff's mortgage. Any person claiming an interest in the surplus funds from the sale, if any, other than the property owner as of the date of the lis pendens must file a claim within 60 days after the sale.

If you are a person with a disability who needs any accommodation in order to participate in this proceeding, you are entitled, at no cost to you, to the provision of certain assistance. Please contact the Public Information Dept., Pasco County Government Center, 7530 Little Rd., New Port Richey, FL 34654; (727) 847-8110 (V) in New Port Richey; (352) 521-4274, ext 8110 (V) in Dade City, at least 7 days before your scheduled court appearance, or immediately upon receiving this notification if the time before the scheduled appearance is less than 7 days; if you are hearing impaired call 711. The court does not provide transportation and cannot accommodate for this service. Persons with disabilities needing transportation to court should contact their local public transportation providers for information regarding transportation services.

Dated this 20th day of March, 2014.  
By: Marc Ruderman, Esq.  
Fl. Bar #899585

Clarfield, Okon, Salomone & Pincus, P.L.  
500 S. Australian Avenue, Suite 730  
West Palm Beach, FL 33401  
(561) 713-1400 -  
Pleadings@cosplaw.com  
Mar. 28; Apr. 4, 2014 14-01813P

## SECOND INSERTION

NOTICE OF SALE IN THE CIRCUIT COURT OF THE SIXTH JUDICIAL CIRCUIT OF THE STATE OF FLORIDA, IN AND FOR PASCO COUNTY CIVIL DIVISION

**CASE NO.:**  
**51-2008-CA-009922-CAAX-ES**  
**BANK OF AMERICA, N.A., Plaintiff, vs.**

**THOMAS R. PATE; GINA PATE; JOSEPH R. BROWN; TAYLOR, BEAN & WHITAKER MORTGAGE CORP., A NOW DISSOLVED CORPORATION; TIMBER CREST ACRES OWNER'S ASSOCIATION, INC.;**

**Defendant(s)**  
Notice is hereby given that, pursuant to a Final Summary Judgment of Foreclosure entered on 01/22/2014 in the above-styled cause, in the Circuit Court of Pasco County, Florida, the office of Paula S. O'Neil clerk of the circuit court will sell the property situate in Pasco County, Florida, described as:

LOT 25, TIMBER CREST ACRES, ACCORDING TO THE PLAT THEREOF AS RECORDED IN PLAT BOOK 40, PAGE 29 OF THE PUBLIC RECORDS OF PASCO COUNTY, FLORIDA.

To include a:  
1998 VIN GMH-  
GA2189820471A 79334736  
1998 VIN GMH-  
GA2189820471B 79335471  
at public sale, to the highest and best bidder, for cash, www.pasco.realfore-

close.com at 11:00 o'clock, A.M., on April 16, 2014

Any person claiming an interest in the surplus from the sale, if any, other than the property owner as of the date of the lis pendens, must file a claim within 60 days after the sale.

If you are a person with a disability who needs any accommodation in order to participate in this proceeding, you are entitled, at no cost to you, to the provision of certain assistance. Please contact the Public Information Dept., Pasco County Government Center, 7530 Little Rd., New Port Richey, FL 34654; (727) 847-8110 (V) for proceedings in New Port Richey; (352) 521-4274, ext. 8110 (V) for proceedings in Dade City, at least 7 days before your scheduled court appearance, or immediately upon receiving this notification if the time before the scheduled appearance is less than 7 days; if you are hearing impaired call 711.

Date: 03/25/2014  
ATTORNEY FOR PLAINTIFF  
By /S/ Josh D. Donnelly  
Josh D. Donnelly  
Florida Bar #64788

THIS INSTRUMENT PREPARED BY:  
Law Offices of Daniel C. Consuegra  
9204 King Palm Drive  
Tampa, FL 33619-1328  
Phone: 813-915-8660  
Attorneys for Plaintiff  
29207-T  
Mar. 28; Apr. 4, 2014 14-01898P

## SECOND INSERTION

NOTICE OF SALE IN THE CIRCUIT CIVIL COURT OF THE SIXTH JUDICIAL CIRCUIT OF FLORIDA, IN AND FOR PASCO COUNTY

CIVIL DIVISION  
**Case No. 51-2012-CA-003546WS**  
**Division J3**

**CITIBANK NA, AS TRUSTEE FOR LEHMAN XS TRUST 2006-17 Plaintiff, vs.**

**MICHAEL MCEWEN A/K/A MICHAEL J. MCEWEN, UNKNOWN SPOUSE OF MICHAEL MCEWEN A/K/A MICHAEL J. MCEWEN, PASCO'S PALM TERRACE HOMEOWNERS INC. F/K/A EXECUTIVE GARDENS ESTATES HOME OWNERS ASSOCIATION, INC., BANK OF AMERICA, N.A., AND UNKNOWN TENANTS/OWNERS, Defendants.**

Notice is hereby given, pursuant to Final Judgment of Foreclosure for Plaintiff entered in this cause on February 26, 2014, in the Circuit Court of Pasco County, Florida, Paula O'Neil, Clerk of the Circuit Court, will sell the property situated in Pasco County, Florida described as:

LOT 204, PALM TERRACE ESTATES UNIT 7, ACCORDING TO THE MAP OR PLAT THEREOF AS RECORDED IN PLAT BOOK 10, PAGE 41, OF THE PUBLIC RECORDS OF PASCO COUNTY, FLORIDA.

and commonly known as: 10834 OAKDALE AVE, PORT RICHEY, FL 34668; including the building, appurtenances, and fixtures located therein,

at public sale, to the highest and best bidder, for cash, www.pasco.realforeclose.com, on April 14, 2014 at 11am.

Any persons claiming an interest in the surplus from the sale, if any, other than the property owner as of the date of the lis pendens must file a claim within 60 days after the sale.

If you are a person with a disability who needs any accommodation in order to participate in this proceeding, you are entitled, at no cost to you, to the provision of certain assistance. Please contact the Public Information Dept., Pasco County Government Center, 7530 Little Rd., New Port Richey, FL 34654; (727) 847-8110 (V) in New Port Richey; (352) 521-4274, ext 8110 (V) in Dade City, at least 7 days before your scheduled court appearance, or immediately upon receiving this notification if the time before the scheduled appearance is less than 7 days; if you are hearing impaired call 711. The court does not provide transportation and cannot accommodate for this service. Persons with disabilities needing transportation to court should contact their local public transportation providers for information regarding transportation services.

By: Edward B. Pritchard  
Attorney for Plaintiff

Invoice to:  
Edward B. Pritchard  
(813) 229-0900 x1309  
Kass Shuler, P.A.  
P.O. Box 800  
Tampa, FL 33601-0800  
ForeclosureService@kasslaw.com  
327611/1122670/amml  
Mar. 28; Apr. 4, 2014 14-01784P

## SECOND INSERTION

NOTICE OF RESCHEDULED FORECLOSURE SALE IN THE CIRCUIT COURT OF THE SIXTH JUDICIAL CIRCUIT IN AND FOR PASCO COUNTY, FLORIDA CIVIL ACTION

**CASE NO.:** 51-2013-CA-003163-ES  
**DIVISION: J5**

**WELLS FARGO BANK, N.A., Plaintiff, vs.**  
**MISTI STRICKLAND, et al, Defendant(s).**

NOTICE IS HEREBY GIVEN pursuant to an Order Rescheduling Foreclosure Sale dated March 12, 2014 and entered in Case No. 51-2013-CA-003163-ES of the Circuit Court of the SIXTH Judicial Circuit in and for PASCO County, Florida wherein WELLS FARGO BANK, N.A., is the Plaintiff and MISTI STRICKLAND; ERIC STRICKLAND; ANY AND ALL UNKNOWN PARTIES CLAIMING BY, THROUGH, UNDER, AND AGAINST THE HEREIN NAMED INDIVIDUAL DEFENDANT(S) WHO ARE NOT KNOWN TO BE DEAD OR ALIVE, WHETHER SAID UNKNOWN PARTIES MAY CLAIM AN INTEREST AS SPOUSES, HEIRS, DEVISEES, GRANTEES, OR OTHER CLAIMANTS; are the Defendants, The Clerk will sell to the highest and best bidder for cash at WWW.PASCO.REALFORECLOSE.COM IN ACCORDANCE WITH CHAPTER 45 FLORIDA STATUTES at 11:00AM, on 04/16/2014, the following described property as set forth in said Final Judgment:

LOT 22, CRYSTAL TERRACE, ACCORDING TO THE MAP

OR PLAT THEROF, AS RECORDED IN PLAT BOOK 6, PAGE 34, OF THE PUBLIC RECORDS OF PASCO COUNTY, FLORIDA.

A/K/A 37840 CRYSTAL WAY, DADE CITY, FL 33523-6918  
Any person claiming an interest in the surplus from the sale, if any, other than the property owner as of the date of the Lis Pendens must file a claim within sixty (60) days after the sale.

\*\*See Americans with Disabilities Act  
"If you are a person with a disability who needs an accommodation in order to participate in this proceeding, you are entitled, at no cost to you, to the provision of certain assistance. Please contact:

Public Information Dept., Pasco County Government Center 7530 Little Rd. New Port Richey, FL 34654 Phone: 727.847.8110 (voice) in New Port Richey 352.521.4274, ext 8110 (voice) in Dade City Or 711 for the hearing impaired

Contact should be initiated at least seven days before the scheduled court appearance, or immediately upon receiving this notification if the time before the scheduled appearance is less than seven days."

By: Luke Kiel  
Florida Bar No. 98631  
Ronald R Wolfe & Associates, P.L.  
P.O. Box 25018  
Tampa, Florida 33622-5018  
(813) 251-4766  
(813) 251-1541 Fax  
F13006456  
Mar. 28; Apr. 4, 2014 14-01795P

## SECOND INSERTION

NOTICE OF RESCHEDULED SALE IN THE CIRCUIT COURT OF THE SIXTH JUDICIAL CIRCUIT IN AND FOR PASCO COUNTY, FLORIDA CIVIL ACTION

**CASE NO.:**  
**51-2010-CA-002902-CAAX-WS**  
**DIVISION: 15**

**JPMORGAN CHASE BANK, NATIONAL ASSOCIATION, Plaintiff, vs.**

**DAVID J. PANARIELLO, et al, Defendant(s).**

NOTICE IS HEREBY GIVEN Pursuant to an Order Rescheduling Foreclosure Sale dated on or about March 12, 2014, and entered in Case No. 51-2010-CA-002902-CAAX-WS of the Circuit Court of the Sixth Judicial Circuit in and for Pasco County, Florida in which JPMorgan Chase Bank, National Association, is the Plaintiff and David J. Panariello, Tenant #1 n/k/a Joe Macchio, are defendants, the Pasco County Clerk of the Circuit Court will sell to the highest and best bidder for cash held online www.pasco.realforeclose.com in Pasco County, Florida, Pasco County, Florida at 11:00AM on the 15th day of April 2014, the following described property as set forth in said Final Judgment of Foreclosure:

LOT 572, EMBASSY HILLS UNIT THREE, ACCORDING TO THE PLAT THEREOF, AS RECORDED IN PLAT BOOK 11, PAGES 119-120, OF THE PUBLIC RECORDS OF PASCO COUNTY, FLORIDA.  
A/K/A 7411 INGLESDRIVE, PORT RICHEY, FL 34668

Any person claiming an interest in the

surplus from the sale, if any, other than the property owner as of the date of the Lis Pendens must file a claim within 60 days after the sale.

If you are a person with a disability who needs an accommodation in order to participate in this proceeding, you are entitled, at no cost to you, to the provision of certain assistance. Please contact:

Public Information Dept., Pasco County Government Center 7530 Little Rd. New Port Richey, FL 34654 Phone: 727.847.8110 (voice) in New Port Richey 352.521.4274, ext 8110 (voice) in Dade City Or 711 for the hearing impaired

Contact should be initiated at least seven days before the scheduled court appearance, or immediately upon receiving this notification if the time before the scheduled appearance is less than seven days.

The court does not provide transportation and cannot accommodate such requests. Persons with disabilities needing transportation to court should contact their local public transportation providers for information regarding transportation services.

Dated in Pasco County, Florida this 20th day of March 2014.

/s/ Erik Del'Etoile  
Erik Del'Etoile, Esq.  
FL Bar # 71675

Albertelli Law  
Attorney for Plaintiff  
P.O. Box 23028  
Tampa, FL 33623  
(813) 221-4743  
JR-10-38560  
Mar. 28; Apr. 4, 2014 14-01815P

## SECOND INSERTION

NOTICE OF FORECLOSURE SALE IN THE CIRCUIT COURT OF THE SIXTH JUDICIAL CIRCUIT, IN AND FOR PASCO COUNTY, FLORIDA CIVIL DIVISION

**CASE NO.:**  
**51-2012-CA-008043-XXXX-WS**  
**JPMORGAN CHASE BANK, NATIONAL ASSOCIATION Plaintiff, vs.**

**KATHLEEN L. CHRISTENSEN, et al Defendants.**

NOTICE IS HEREBY GIVEN pursuant to a Summary Final Judgment of foreclosure dated February 13, 2014, and entered in Case No. 51-2012-CA-008043-XXXX-WS of the Circuit Court of the SIXTH Judicial Circuit in and for PASCO COUNTY, Florida, wherein JPMORGAN CHASE BANK, NATIONAL ASSOCIATION, is Plaintiff, and KATHLEEN L. CHRISTENSEN, et al are Defendants, the clerk will sell to the highest and best bidder for cash, beginning at 11:00 AM at www.pasco.realforeclose.com, in accordance with Chapter 45, Florida Statutes, on the 15 day of April, 2014, the following described property as set forth in said Summary Final Judgment, to wit:

Unit B, Building 221, BEACON LAKES CONDOMINIUM, INC., PHASE 5-A, according to the Declaration of Condominium Number thereof, as recorded in Official Records Book 783, Pages 172-252 and any amendments thereto and according to the plat thereof, recorded in Plat Book 13, Pages 104-106, of the Public Records of Pasco County, Florida.

Any person claiming an interest in the surplus funds from the sale, if any,

other than the property owner as of the date of the lis pendens must file a claim within 60 days after the sale.

If you are a person with a disability who needs any accommodation in order to participate in this proceeding, you are entitled, at no cost to you, to the provision of certain assistance. Please contact the Public Information Dept., Pasco County Government Center, 7530 Little Rd., New Port Richey, FL 34654; (727) 847-8110 (v) in New Port Richey; (352) 521-4274, ext 8110 (v) in Dade City, at least seven (7) days before your scheduled court appearance, or immediately upon receiving this notification if the time before the scheduled appearance is less than seven (7) days; if you are hearing or voice impaired, call 711.

The court does not provide transportation and cannot accommodate for this service. Persons with disabilities needing transportation to court should contact their local public transportation providers for information regarding transportation services.

Dated: March 19, 2014

By: /s/ Heather J. Koch  
Phelan Hallinan, PLC  
Heather J. Koch, Esq.,  
Florida Bar No. 89107  
Emilio R. Lenzi, Esq.,  
Florida Bar No. 0668273  
Phelan Hallinan, PLC  
Attorneys for Plaintiff  
2727 West Cypress Creek Road  
Ft. Lauderdale, FL 33309  
Tel: 954-462-7000  
Fax: 954-462-7001  
Service by email:  
FL.Service@PhelanHallinan.com  
PH # 30333  
Mar. 28; Apr. 4, 2014 14-01801P

## SECOND INSERTION

NOTICE OF RESCHEDULED SALE IN THE CIRCUIT COURT OF THE SIXTH JUDICIAL CIRCUIT IN AND FOR PASCO COUNTY, FLORIDA CIVIL ACTION

**CASE NO.:**  
**51-2011-CA-004867-CAAX-WS**  
**JPMORGAN CHASE BANK, NATIONAL ASSOCIATION, Plaintiff, vs.**

**BRIAN C. LOWERY, et al, Defendant(s).**

NOTICE IS HEREBY GIVEN Pursuant to an Order Rescheduling Foreclosure Sale dated on or about February 19, 2014, and entered in Case No. 51-2011-CA-004867-CAAX-WS of the Circuit Court of the Sixth Judicial Circuit in and for Pasco County, Florida in which JPMorgan Chase Bank, National Association, is the Plaintiff and Brian C. Lowery, Colleen E. Rustay, Beacon Square Civic Association, Inc., Pinellas Federal Credit Union, Tenant #1 n.k.a Toni Meeker, Tenant #2 n.k.a Gary Meeker, are defendants, the Pasco County Clerk of the Circuit Court will sell to the highest and best bidder for cash in/on held online www.pasco.realforeclose.com: in Pasco County, Florida, Pasco County, Florida at 11:00AM on the 15th day of April, 2014, the following described property as set forth in said Final Judgment of Foreclosure:

LOT 1656, BEACON SQUARE UNIT 13-B, ACCORDING TO THE MAP OR PLAT THEREOF, AS RECORDED IN PLAT BOOK 9, PAGE 119, PUBLIC RECORDS OF PASCO COUNTY, FLORIDA. A/K/A 3247 COLUMBUS DRIVE, HOLIDAY, FL 34691-1040

Any person claiming an interest in the surplus from the sale, if any, other than

the property owner as of the date of the Lis Pendens must file a claim within 60 days after the sale.

If you are a person with a disability who needs an accommodation in order to participate in this proceeding, you are entitled, at no cost to you, to the provision of certain assistance. Please contact:

Public Information Dept., Pasco County Government Center 7530 Little Rd. New Port Richey, FL 34654 Phone: 727.847.8110 (voice) in New Port Richey 352.521.4274, ext 8110 (voice) in Dade City Or 711 for the hearing impaired

Contact should be initiated at least seven days before the scheduled court appearance, or immediately upon receiving this notification if the time before the scheduled appearance is less than seven days.

The court does not provide transportation and cannot accommodate such requests. Persons with disabilities needing transportation to court should contact their local public transportation providers for information regarding transportation services.

Dated in Hillsborough County, Florida on this 21st day of March, 2014.

/s/ Erik Del'Etoile  
Erik Del'Etoile, Esq.  
FL Bar # 71675

Albertelli Law  
Attorney for Plaintiff  
P.O. Box 23028  
Tampa, FL 33623  
(813) 221-4743  
(813) 221-9171 facsimile  
eService:  
servealaw@albertellilaw.com  
BM - 10-51955  
Mar. 28; Apr. 4, 2014 14-01836P

## SECOND INSERTION

NOTICE OF SALE IN THE CIRCUIT COURT OF THE SIXTH JUDICIAL CIRCUIT IN AND FOR PASCO COUNTY, FLORIDA CIVIL DIVISION

**Case #: 51-2012-CA-008361-WS**  
**DIVISION: J3**

**Wells Fargo Bank, National Association Plaintiff, vs.-**  
**Christopher M. Oliver; Unknown Spouse of Christopher M. Oliver; Lone Star Ranch Homeowners Association, Inc.; Unknown Parties in Possession #1, If living, and all Unknown Parties claiming by, through, under and against the above named Defendant(s) who are not known to be dead or alive, whether said Unknown Parties may claim an interest as Spouse, Heirs, Devisees, Grantees, or Other Claimants; Unknown Parties in Possession #2, If living, and all Unknown Parties claiming by, through, under and against the above named Defendant(s) who are not known to be dead or alive, whether said Unknown Parties may claim an interest as Spouse, Heirs, Devisees, Grantees, or Other Claimants**

NOTICE IS HEREBY GIVEN pursuant to an Order rescheduling foreclosure sale, entered in Civil Case No. 51-2012-CA-008361-WS of the Circuit Court of the 6th Judicial Circuit in and for Pasco County, Florida, wherein Wells Fargo Bank, National Association, Plaintiff and Christopher M. Oliver are defendant(s), I, Clerk of Court, Paula S. O'Neil, will sell to the highest and best bidder for cash In an online

sale accessed through the Clerk's website at www.pasco.realforeclose.com, at 11:00 a.m. on April 17, 2014, the following described property as set forth in said Final Judgment, to-wit:

LOT 3, BLOCK 4, LONESTAR TOWNHOMES, ACCORDING TO THE MAP OR PLAT THEREOF, AS RECORDED IN PLAT BOOK 58, PAGES 7-14, OF THE PUBLIC RECORDS OF PASCO COUNTY, FLORIDA.

ANY PERSON CLAIMING AN INTEREST IN THE SURPLUS FROM THE SALE, IF ANY, OTHER THAN THE PROPERTY OWNER AS OF THE DATE OF THE LIS PENDENS MUST FILE A CLAIM WITHIN 60 DAYS AFTER THE SALE.

If you are a person with a disability who needs any accommodation in order to participate in this proceeding, you are entitled, at no cost to you, to the provision of certain assistance. Please contact the ADA Coordinator; 14250 49th Street North, Clearwater, Florida 33762 (727) 453-7163 at least 7 days before your scheduled court appearance, or immediately upon receiving this notification of the time before the scheduled appearance is less than 7 days. If you are hearing or voice impaired, call 711.

Submitted By:  
ATTORNEY FOR PLAINTIFF:  
SHAPIRO, FISHMAN & GACHÉ, LLP  
2424 North Federal Highway,  
Suite 360  
Boca Raton, Florida 33431  
(561) 998-6700  
(561) 998-6707  
BM - 12-53019 FCO1 WNI  
Mar. 28; Apr. 4, 2014 14-01838P

SECOND INSERTION

NOTICE OF SALE IN THE CIRCUIT COURT OF THE SIXTH JUDICIAL CIRCUIT OF THE STATE OF FLORIDA, IN AND FOR PASCO COUNTY CIVIL DIVISION CASE NO.

51-2012-CA-004486-CAAX-WS GREEN TREE SERVICING LLC, Plaintiff, vs.

HERMAN G. BORKHUIS; UNKNOWN SPOUSE OF HERMAN G. BORKHUIS; CAROL RICHARD; UNKNOWN SPOUSE OF CAROL RICHARD; TIMBER OAKS COMMUNITY SERVICES ASSOCIATION, INC.; UNKNOWN TENANT #1; UNKNOWN TENANT #2;

Defendant(s) Notice is hereby given that, pursuant to a Final Summary Judgment of Foreclosure entered on 02/18/2014 in the above-styled cause, in the Circuit Court of Pasco County, Florida, the office of

Paula S. O'Neil clerk of the circuit court will sell the property situate in Pasco County, Florida, described as: Lot 33, TIMBER OAKS, TRACT 13, PHASE 2, according to the plat thereof, as recorded in Plat Book 16, Pages 117 through 119, of the Public Records of Pasco County, Florida.

at public sale, to the highest and best bidder, for cash, www.pasco.realforeclose.com at 11:00 o'clock, A.M, on April 15, 2014

Any person claiming an interest in the surplus from the sale, if any, other than the property owner as of the date of the lis pendens, must file a claim within 60 days after the sale.

If you are a person with a disability who needs any accommodation in order to participate in this proceeding, you are entitled, at no cost to you, to the provision of certain assistance. Please contact the Public Information Dept., Pasco County Government

Center, 7530 Little Rd., New Port Richey, FL 34654; (727) 847-8110 (V) for proceedings in New Port Richey; (352) 521-4274, ext. 8110 (V) for proceedings in Dade City, at least 7 days before your scheduled court appearance, or immediately upon receiving this notification if the time before the scheduled appearance is less than 7 days; if you are hearing impaired call 711.

Date: 03/21/2014  
ATTORNEY FOR PLAINTIFF  
By /s/ Josh D. Donnelly  
Josh D. Donnelly  
Florida Bar #64788

THIS INSTRUMENT PREPARED BY:  
Law Offices of Daniel C. Consuegra  
9204 King Palm Drive  
Tampa, FL 33619-1328  
Phone: 813-915-8660  
Attorneys for Plaintiff  
121599  
Mar. 28; Apr. 4, 2014 14-01849P

SECOND INSERTION

County, Florida:

Lot 1343, BEACON WOODS, VILLAGE 5-B according to the Plat thereof as recorded in Plat Book 11, Page 89 through 91 of the Public Records of Pasco County, Florida.

pursuant to the Final Judgment entered in a case pending in said Court, the style of which is indicated above.

Any person or entity claiming an interest in the surplus, if any, resulting from the foreclosure sale, other than the property owner as of the date of the Lis Pendens, must file a claim on same with the Clerk of Court within 60 days after the foreclosure sale.

AMERICANS WITH DISABILITIES ACT. If you are a person with a disability who needs any accommodation in order to participate in this proceeding, you are entitled, at no cost to you, to the provi-

sion of certain assistance. Please contact the Human Rights Office, 400 S. Ft. Harrison Ave., Ste. 500 Clearwater, FL 33756, (727) 464-4880(V) at least 7 days before your scheduled court appearance, or immediately upon receiving this notification if the time before the scheduled appearance is less than 7 days; if you are hearing impaired call 711.

DATED this 19th day of March, 2014

Chris Bertels, Esquire  
Florida Bar No: 98267  
BUTLER & HOSCH, P.A.  
3185 South Conway Road, Suite E  
Orlando, Florida 32812  
Telephone: (407) 381-5200  
Fax: (407) 381-5577  
Cb98267@butlerandhosch.com  
FLpleadings@butlerandhosch.com  
B&H # 271864  
Mar. 28; Apr. 4, 2014 14-01792P

SECOND INSERTION

NOTICE OF FORECLOSURE SALE IN THE CIRCUIT COURT OF THE SIXTH JUDICIAL CIRCUIT IN AND FOR PASCO COUNTY, FLORIDA CIVIL DIVISION CASE NO.

51-2011-CA-004101-CAAX-ES SECTION: J1

TIMBER LAKE ESTATES, INC., a Florida not for profit corporation, Plaintiff, vs.

TIMOTHY D. PLUMMER and ANY UNKNOWN OCCUPANTS IN POSSESSION, Defendants.

NOTICE IS HEREBY GIVEN pursuant to a Final Judgment of Foreclosure dated the March 20, 2012 and the Order on Motion to Reset Foreclosure Sale dated March 6, 2014 entered in Case No. 51-2011-CA-004101-CAAX-ES of the Circuit Court of the Sixth Judicial Circuit in and for Pasco County, Florida, wherein Timber Lake Estates, Inc., a Florida not-for-profit corporation, is the Plaintiff, and Timothy D. Plummer is the Defendant, I will sell to the highest and best bidder for cash online via the internet at http://www.pasco.realforeclose.com at 11:00 AM, on the 17th day of April, 2014, the following described property as set forth in said Final Judgment:

Parcel 284, TIMBER LAKE ESTATES, A Condominium, Phase III, and the undivided percentage of interest or share in the common elements appurtenant thereto in accordance with and subject to the covenants, conditions, restrictions, easements, terms and other provisions of the Declaration of Condominium of TIMBER LAKE ESTATES, A CONDOMINIUM, PHASE III, as recorded in Official Record Book 1369, Pages 484 through 537, and amended in Official Records Book 1372, Pages 598 to 602, and thereby supplemented by Official Record Book 1468, Page 133 and thereby amended in Official Record Book 1468, Page 141, and the Plat thereof

recorded in Condominium Plat Book 2, pages 37 thru 38, Public Records of Pasco County, Florida; and all future amendments and/or supplements thereto. TOGETHER WITH 1990 GLEN MOBILE HOME VIN #57620464AZ & #57620464BZ. With the following street address: 34040 Estates Lane, Zephyrhills, Florida 33543.

Any person claiming an interest in the surplus from the sale, if any, other than the property owner is of the date of the Lis Pendens must file a claim within sixty (60) days after the sale.

If you are a person with a disability who needs any accommodation in order to participate in this proceeding, you are entitled, at no cost to you, to the provision of certain assistance. Please contact the Public Information Dept., Pasco County Government Center, 7530 Little Rd., New Port Richey, FL 34654; (727) 847-8110 (V) in New Port Richey; (352) 521-4274, ext 8110 (V) in Dade City, at least 7 days before your scheduled court appearance, or immediately upon receiving this notification if the time before the scheduled appearance is less than 7 days; if you are hearing impaired call 711. The court does not provide transportation and cannot accommodate for this service.

Persons with disabilities needing transportation to court should contact their local public transportation providers for information regarding transportation services.

/s/ Jana M. Hampton, Esq.  
Jana M. Hampton, Esquire  
Florida Bar No. 61136  
Western White Zetrouer, P.A.  
146 2nd St. N., Ste 100  
St. Petersburg, Florida 33701  
T 727/329-8956  
F 727/329-8960  
Attorney for Plaintiff  
Primary email: litigation@wvw-law.com  
Secondary email: slueck@wvw-law.com  
Mar. 28; Apr. 4, 2014 14-01808P

RE-NOTICE OF SALE PURSUANT TO CHAPTER 45 IN THE SIXTH JUDICIAL CIRCUIT OF THE SIXTH JUDICIAL CIRCUIT IN AND FOR PASCO COUNTY, FLORIDA. CIVIL DIVISION CASE NO. 51-2010-CA-454 WS/J2 UCN: 512010CA000454XXXXXX

U.S. BANK NATIONAL ASSOCIATION, AS TRUSTEE FOR TERWIN MORTGAGE TRUST 2005-14HE, ASSET-BACKED CERTIFICATES, SERIES 2005-14HE, Plaintiff, vs.

MARK WIRZBURGER; UNKNOWN TENANT NO. 1; UNKNOWN TENANTS NO. 2; and ALL UNKNOWN PARTIES CLAIMING INTERESTS BY, THROUGH, UNDER OR AGAINST A NAMED DEFENDANT TO THIS ACTION, OR HAVING OR CLAIMING TO HAVE ANY RIGHT, TITLE OR INTEREST IN THE PROPERTY HEREIN DESCRIBED, Defendants.

NOTICE IS HEREBY GIVEN pursuant to an Order or Summary Final Judgment of foreclosure dated June 6, 2014, and entered in Case No. 51-2010-CA-454 WS/J2 UCN: 512010CA000454XXXXXX of the Circuit Court in and for Pasco County, Florida, wherein U.S. BANK NATIONAL ASSOCIATION, AS TRUSTEE FOR TERWIN MORTGAGE TRUST 2005-14HE, ASSET-BACKED CERTIFICATES, SERIES 2005-14HE is Plaintiff and MARK WIRZBURGER; UNKNOWN TENANT NO. 1; UNKNOWN TENANTS NO. 2; and ALL UNKNOWN PARTIES CLAIMING INTERESTS BY, THROUGH, UNDER OR AGAINST A NAMED DEFENDANT TO THIS ACTION, OR HAVING OR CLAIMING TO HAVE ANY RIGHT, TITLE OR INTEREST IN THE PROPERTY HEREIN DESCRIBED, are Defen-

dants, PAULA S O'NEIL, Clerk of the Circuit Court, will sell to the highest and best bidder for cash www.pasco.realforeclose.com County, Florida, 11:00 a.m. on the 7th day of April, 2014, the following described property as set forth in said Order or Final Judgment, to-wit:

LOT 256, BEACON SQUARE, UNIT FOUR, AS PER PLAT THEREOF, RECORDED IN PLAT BOOK 8, PAGE 90, OF THE PUBLIC RECORDS OF PASCO COUNTY, FLORIDA. ANY PERSON CLAIMING AN INTEREST IN THE SURPLUS FROM THE SALE, IF ANY, OTHER THAN THE PROPERTY OWNER AS OF THE DATE OF THE LIS PENDENS MUST FILE A CLAIM WITHIN 60 DAYS AFTER THE SALE.

Pursuant to Florida Statute 45.031(2), this notice shall be published twice, once a week for two consecutive weeks, with the last publication being at least 5 days prior to the sale.

In accordance with the Americans with Disabilities Act of 1990, persons needing special accommodation to participate in this proceeding should contact the Clerk of the Court not later than five business days prior to the proceeding at the Pasco County Courthouse. Telephone 352-521-4545 (Dade City) 352-847-2411 (New Port Richey) or 1-800-955-8770 via Florida Relay Service.

DATED at New Port Richey, Florida, on 3/21, 2014.

By: Gabrielle Gutt Bar # 00595633 Kathleen E. Angione Florida Bar No. 175651 SHD Legal Group P.A. Attorneys for Plaintiff PO BOX 11438 Fort Lauderdale, FL 33339-1438 Telephone: (954) 564-0071 Facsimile: (954) 564-9252 Service E-mail: answers@shdlegalgroup.com 1396-79534 CAA Mar. 28; Apr. 4, 2014 14-01839P

SECOND INSERTION

NOTICE OF FORECLOSURE SALE IN THE CIRCUIT COURT OF THE SIXTH JUDICIAL CIRCUIT IN AND FOR PASCO COUNTY, FLORIDA GENERAL JURISDICTION DIVISION CASE NO.

51-2009-CA-003043-WS (J2) THE BANK OF NEW YORK MELLON F/K/A THE BANK OF NEW YORK, AS SUCCESSOR TO JPMORGAN CHASE BANK, NA F/K/A JPMORGAN CHASE BANK AS TRUSTEE UNDER THE POOLING AND SERVICING AGREEMENT DATED AS OF MARCH 1, 2004 AMONT ASSET BACKED FUNDING CORPORATION LITTON LOAN SERVICING LP ABFC ASSET-BACKED CERTIFICATES, SERIES 2004-AHLI, Plaintiff, vs.

LUIS M. SETA, et al. Defendant(s).

NOTICE IS HEREBY GIVEN pursuant to a Final Judgment of Foreclosure dated February 26, 2014, and entered in 51-2009-CA-003043-WS (J2) of the Circuit Court of the Sixth Judicial Circuit in and for Pasco County, Florida, wherein THE BANK OF NEW YORK MELLON F/K/A THE BANK OF NEW YORK, AS SUCCESSOR TO JPMORGAN CHASE BANK, NA F/K/A JPMORGAN CHASE BANK AS TRUSTEE UNDER THE POOLING AND SERVICING AGREEMENT DATED AS OF MARCH 1, 2004 AMONT ASSET BACKED FUNDING CORPORATION LITTON LOAN SERVICING LP ABFC ASSET-BACKED CERTIFICATES, SERIES 2004-AHLI, is the Plaintiff and LUIS M SETA; NORA CAROLINA SETA F/K/A NORA C SETA; NATURE'S HIDEAWAY PHASE IV HOMEOWNERS ASSOCIATION INC.; NATURE'S HIDEAWAY MASTER ASSOCIATION INC.; MORTGAGE ELECTRONIC REGISTRATION SYSTEMS, INC.; UNKNOWN TENANTS are the Defendant(s). Paula O'Neil as the

Clerk of the Circuit Court will sell to the highest and best bidder for cash, www.pasco.realforeclose.com, at 11:00 AM on April 17, 2014, the following described property as set forth in said Final Judgment, to wit:

LOT 313, NATURES HIDEAWAY, PHASE IV, ACCORDING TO THE MAP OR PLAT THEREOF, AS RECORDED IN PLAT BOOK 27, PAGES 109-113, OF THE PUBLIC RECORDS OF PASCO COUNTY, FLORIDA.

Any person claiming an interest in the surplus from the sale, if any, other than the property owner as of the date of the lis pendens must file a claim within 60 days after the sale.

IMPORTANT If you are a person with a disability who needs any accommodation in order to participate in this proceeding, you are entitled, at no cost to you, to the provision of certain assistance. Please contact the Public Information Dept., Pasco County Government Center, 7530 Little Rd., New Port Richey, FL 34654; (727) 847-8110 (V) in New Port Richey; (352) 521-4274, ext 8110 (V) in Dade City, at least 7 days before your scheduled court appearance, or immediately upon receiving this notification if the time before the scheduled appearance is less than 7 days; if you are hearing impaired call 711. The court does not provide transportation and cannot accommodate for this service. Persons with disabilities needing transportation to court should contact their local public transportation providers for information regarding transportation services. Dated this 24th day of March, 2014. By: Liana R. Hall FL Bar No. 73813 for Hillary Rosenzweig Florida Bar: 105522 Robertson, Anschutz & Schneid, PL Attorneys for Plaintiff 6409 Congress Avenue, Suite 100 Boca Raton, Florida 33487 13-15346 Mar. 28; Apr. 4, 2014 14-01881P

SECOND INSERTION

NOTICE OF RESCHEDULED SALE IN THE CIRCUIT COURT OF THE SIXTH JUDICIAL CIRCUIT IN AND FOR PASCO COUNTY, FLORIDA CIVIL ACTION CASE NO.:

51-2011-CA-001443-CAAX-ES NATIONSTAR MORTGAGE LLC, Plaintiff, vs.

KEVIN CLINE, et al, Defendant(s).

NOTICE IS HEREBY GIVEN Pursuant to an Order Rescheduling Foreclosure Sale dated on or about February 27, 2014, and entered in Case No. 51-2011-CA-001443-CAAX-ES of the Circuit Court of the Sixth Judicial Circuit in and for Pasco County, Florida in which Nationstar Mortgage LLC, is the Plaintiff and Kevin Cline, Tenant #1, Tenant #2, Unknown Spouse of Kevin Cline, are defendants, the Pasco County Clerk of the Circuit Court will sell to the highest and best bidder for cash in/on held online www.pasco.realforeclose.com in Pasco County, Florida, Pasco County, Florida at 11:00AM on the 14th day of April, 2014, the following described property as set forth in said Final Judgment of Foreclosure: THE NORTH 135.0 FEET OF THE SOUTH 729.0 FEET OF THE SOUTHWEST 1/4, LESS THE EAST 1029.0 FEET THEREOF AND LESS ROAD RIGHT-OF-WAY; AND THE SOUTHWEST 1/4 OF THE SOUTHWEST 1/4, LESS THE SOUTH 729.0 FEET THEREOF AND LESS ROAD RIGHT-OF-WAY; THE WEST 80.0 FEET OF THE NORTH 320.0 FEET THEREOF RESERVED FOR RIGHT OF INGRESS AND EGRESS AND THE SOUTH 280.0 FEET OF THE NORTHWEST 1/4 OF THE SOUTHWEST 1/4; THE WEST 80.0 FEET THEREOF RESERVED FOR THE RIGHT OF INGRESS AND EGRESS; AND THAT PART OF THE NORTHEAST 1/4 OF THE SOUTHWEST 1/4 LYING SOUTHWESTERLY OF

RAILROAD. ALL LYING AND BEING IN SECTION 22, TOWNSHIP 23 SOUTH, RANGE 21 EAST, PASCO COUNTY, FLORIDA. A/K/A 21150 TRILBY CEMETERY ROAD, DADE CITY, FL 33523-1302

Any person claiming an interest in the surplus from the sale, if any, other than the property owner as of the date of the Lis Pendens must file a claim within 60 days after the sale.

If you are a person with a disability who needs an accommodation in order to participate in this proceeding, you are entitled, at no cost to you, to the provision of certain assistance. Please contact:

Public Information Dept., Pasco County Government Center 7530 Little Rd. New Port Richey, FL 34654 Phone: 727.847.8110 (voice) in New Port Richey 352.521.4274, ext 8110 (voice) in Dade City Or 711 for the hearing impaired Contact should be initiated at least seven days before the scheduled court appearance, or immediately upon receiving this notification if the time before the scheduled appearance is less than seven days.

The court does not provide transportation and cannot accommodate such requests. Persons with disabilities needing transportation to court should contact their local public transportation providers for information regarding transportation services.

Dated in Hillsborough County, Florida on this 19th day of March, 2014.

/s/ Erik Del'Etoile Erik Del'Etoile, Esq. FL Bar # 71675 Albertelli Law Attorney for Plaintiff P.O. Box 23028 Tampa, FL 33623 (813) 221-4743 (813) 221-9171 facsimile service: servealaw@albertellilaw.com BM - 10-55381 Mar. 28; Apr. 4, 2014 14-01786P

NOTICE OF RESCHEDULED FORECLOSURE SALE IN THE CIRCUIT COURT OF THE SIXTH JUDICIAL CIRCUIT IN AND FOR PASCO COUNTY, FLORIDA CIVIL ACTION CASE NO.:

51-2007-CA-006585-ES DIVISION: J1

DEUTSCHE BANK NATIONAL TRUST COMPANY, AS TRUSTEE UNDER THE POOLING AND SERVICING AGREEMENT RELATING TO IMPAC SECURED ASSETS CORPORATION, MORTGAGE PASS-THROUGH CERTIFICATES, SERIES 2006-3, Plaintiff, vs.

CHRISTOPHER M RODRIGUEZ A/K/A CHRISTOPHER RODRIGUEZ A/K/A CHRIS RODRIGUEZ, et al, Defendant(s).

NOTICE IS HEREBY GIVEN pursuant to an Order Rescheduling Foreclosure Sale dated March 7, 2014 and entered in Case NO. 51-2007-CA-006585-ES of the Circuit Court of the SIXTH Judicial Circuit in and for Pasco County, Florida wherein DEUTSCHE BANK NATIONAL TRUST COMPANY, AS TRUSTEE UNDER THE POOLING AND SERVICING AGREEMENT RELATING TO IMPAC SECURED ASSETS CORPORATION, MORTGAGE PASS-THROUGH CERTIFICATES, SERIES 2006-3, is the Plaintiff and CHRISTOPHER M RODRIGUEZ A/K/A CHRISTOPHER RODRIGUEZ A/K/A CHRIS RODRIGUEZ, THE UNKNOWN SPOUSE OF CHRISTOPHER M RODRIGUEZ A/K/A CHRISTOPHER RODRIGUEZ A/K/A CHRIS RODRIGUEZ N/K/A SUE BRICENO; MORTGAGE ELECTRONIC REGISTRATION SYSTEMS, INCORPORATED, AS NOMINEE FOR COUNTRYWIDE FINANCIAL CORPORATION; KEYBANK NATIONAL ASSOCIATION; PASCO COUNTY; PASCO COUNTY CLERK OF THE CIRCUIT COURT; STATE OF FLORIDA; are the Defen-

dants, The Clerk will sell to the highest and best bidder for cash at WWW.PASCO.REALFORECLOSE.COM IN ACCORDANCE WITH CHAPTER 45 FLORIDA STATUTES at 11:00AM, on 04/16/2014, the following described property as set forth in said Final Judgment:

LOT 36, BLOCK 4, BALLANTRAE VILLAGE 5, ACCORDING TO THE MAP OR PLAT THEREOF AS RECORDED IN PLAT BOOK 52, PAGE(S) 30-49 OF THE PUBLIC RECORDS OF PASCO COUNTY, FLORIDA A/K/A 3938 STORNOWAY DRIVE, LAND O LAKES, FL 34638

Any person claiming an interest in the surplus from the sale, if any, other than the property owner as of the date of the Lis Pendens must file a claim within sixty (60) days after the sale.

\*\*See Americans with Disabilities Act "If you are a person with a disability who needs an accommodation in order to participate in this proceeding, you are entitled, at no cost to you, to the provision of certain assistance. Please contact:

Public Information Dept., Pasco County Government Center 7530 Little Rd. New Port Richey, FL 34654 Phone: 727.847.8110 (voice) in New Port Richey 352.521.4274, ext 8110 (voice) in Dade City Or 711 for the hearing impaired Contact should be initiated at least seven days before the scheduled court appearance, or immediately upon receiving this notification if the time before the scheduled appearance is less than seven days." By: J. Bennett Kitterman Florida Bar No. 98636 Ronald R Wolfe & Associates, P.L. P.O. Box 25018 Tampa, Florida 33622-5018 (813) 251-4766 (813) 251-1541 Fax F07054155 Mar. 28; Apr. 4, 2014 14-01796P

SECOND INSERTION

NOTICE OF RESCHEDULED FORECLOSURE SALE IN THE CIRCUIT COURT OF THE SIXTH JUDICIAL CIRCUIT IN AND FOR PASCO COUNTY, FLORIDA CIVIL ACTION CASE NO.:

51-2011-CA-002712 ES DIVISION: J4

DEUTSCHE BANK NATIONAL TRUST COMPANY, AS TRUSTEE FOR HSI ASSET SECURITIZATION CORP TRUST 2007-NCL, Plaintiff, vs.

LILLIAN HUNTER, et al, Defendant(s).

NOTICE IS HEREBY GIVEN pursuant to an Order Rescheduling Foreclosure Sale dated March 7, 2014 and entered in Case No. 51-2011-CA-002712 ES of the Circuit Court of the SIXTH Judicial Circuit in and for Pasco County, Florida wherein DEUTSCHE BANK NATIONAL TRUST COMPANY, AS TRUSTEE FOR HSI ASSET SECURITIZATION CORP TRUST 2007-NCL, is the Plaintiff and LILLIAN HUNTER; CHEATIA DAMON; STEPHANIE ELLIOTT; THE UNKNOWN SPOUSE OF STEPHANIE ELLIOTT N/K/A TAVARIS ELLIOTT; THE UNKNOWN HEIRS, DEVISEES, GRANTEES, ASSIGNEES, LIENORS, CREDITORS, TRUSTEES, OR OTHER CLAIMANTS CLAIMING BY, THROUGH, UNDER, OR AGAINST IDELLA WALKER A/K/A IDELLA SMITH WALKER A/K/A IDELLA S. WALKER A/K/A IDELLA S. HOLDER, DECEASED; LILLIAN KATHERIN HUNTER A/K/A LILLIAN K. HUNTER, AS AN HEIR OF THE ESTATE OF IDELLA WALKER A/K/A IDELLA SMITH WALKER A/K/A IDELLA S. WALKER A/K/A IDELLA S. HOLDER, DECEASED; ANY AND ALL UNKNOWN PARTIES CLAIMING BY, THROUGH, UNDER, AND AGAINST THE HEREIN NAMED INDIVIDUAL DEFENDANT(S) WHO ARE NOT KNOWN TO BE DEAD OR ALIVE, WHETHER SAID UNKNOWN PARTIES MAY CLAIM AN INTEREST AS SPOUSES, HEIRS,

DEWISEES, GRANTEES, OR OTHER CLAIMANTS; CITIFINANCIAL, INC.; are the Defendants, The Clerk will sell to the highest and best bidder for cash at WWW.PASCO.REALFORECLOSE.COM IN ACCORDANCE WITH CHAPTER 45 FLORIDA STATUTES at 11:00AM, on 04/16/2014, the following described property as set forth in said Final Judgment:

THE NORTH 1/2 OF LOT 27 AND LOT 28 MICKENS HARPER SUBDIVISION, AS PER MAP BOOK 3, PAGE 158, PUBLIC RECORDS OF PASCO COUNTY, FLORIDA. A/K/A 14347 DELMAR STREET, DADE CITY, FL 33525

Any person claiming an interest in the surplus from the sale, if any, other than the property owner as of the date of the Lis Pendens must file a claim within sixty (60) days after the sale.

\*\*See Americans with Disabilities Act "If you are a person with a disability who needs an accommodation in order to participate in this proceeding, you are entitled, at no cost to you, to the provision of certain assistance. Please contact:

Public Information Dept., Pasco County Government Center 7530 Little Rd. New Port Richey, FL 34654 Phone: 727.847.8110 (voice) in New Port Richey 352.521.4274, ext 8110 (voice) in Dade City Or 711 for the hearing impaired Contact should be initiated at least seven days before the scheduled court appearance, or immediately upon receiving this notification if the time before the scheduled appearance is less than seven days." By: Luke Kiel Florida Bar No. 98631 Ronald R Wolfe & Associates, P.L. P.O. Box 25018 Tampa, Florida 33622-5018 (813) 251-4766 (813) 251-1541 Fax F11018396 Mar. 28; Apr. 4, 2014 14-01797P

## SECOND INSERTION

NOTICE OF SALE IN THE CIRCUIT COURT OF THE SIXTH JUDICIAL CIRCUIT IN AND FOR PASCO COUNTY, FLORIDA CASE NO.: 51-2012-CA-008148-WS SEA PAC PORTFOLIO, LLC, Plaintiff, vs. JOSEPH RUWELL; et al., Defendants. NOTICE is hereby given that pursuant to the Final Judgment of Foreclosure entered in the cause pending in the Circuit Court of the Sixth Judicial Circuit, in and for Pasco County, Florida, Case No. 51-2012-CA-008148-WS, in which SEA PAC Portfolio, LLC, is Plaintiff, and Joseph Ruwell, Julia Ruwell, Defendants, the Clerk of Court for Pasco County will sell the following described property situated in Pasco County, Florida:

Lot 102, Ridge Crest Gardens, according to the map or plat thereof, as recorded in Plat Book 12, Page(s) 4 through 7, inclusive, of the Public Records of Pasco County, Florida. Together with an undivided percentage interest in the common elements pertaining thereto at public sale, to the highest and best bidder for cash at 11:00 am on the 24th day of April, 2014, all sales are online at www.pasco.realforeclose.com.

Any person claiming interest in the surplus from the sale, if any, other than the property owner as of the date of the lis pendens must file a claim within 60 days after the sale.

If you are a person with a disability who needs any accommodation in order to participate in this proceeding, you are entitled, at no cost to you to the provision of certain assistance. Within two (2) working days of your receipt of this (describe notice/order) please contact the Public Information Dept., Pasco County Government Center, 7530 Little Rd., New Port Richey, FL 34654; (727) 847-8110 (V) in New Port Richey; (352) 521-4274, ext. 8110 (V) in Dade City; via 1-800-955-8771 if you are hearing impaired. The court does not provide transportation and cannot accommodate for this service. Persons with disabilities needing transportation to court should contact their local public transportation providers for information regarding disabled transportation services.

DATED this 21st day of March, 2014. CAMERON H.P. WHITE Florida Bar No. 021343 cwhite@southmillhausen.com JASON R. HAWKINS Florida Bar No. 011925 jhawkins@southmillhausen.com LINDSEY M. DAVIS Florida Bar No. 065711 ldavis@southmillhausen.com South Millhausen, P.A. 1000 Legion Place, Suite 1200 Orlando, Florida 32801 Telephone: (407) 539-1638 Facsimile: (407) 539-2679 Attorneys for Plaintiff Mar. 28; Apr. 4, 2014 14-01814P

## SECOND INSERTION

NOTICE OF SALE IN THE CIRCUIT COURT OF THE SIXTH JUDICIAL CIRCUIT IN AND FOR PASCO COUNTY, FLORIDA CASE NO. 51-2010-CA-007747-WS US BANK, N.A., SUCCESSOR BY MERGER TO THE LEADER MORTGAGE COMPANY Plaintiff, v.

JOHN A. GUENTHNER; UNKNOWN SPOUSE OF JOHN A. GUENTHNER; UNKNOWN TENANT 1; UNKNOWN TENANT 2; AND ALL UNKNOWN PARTIES CLAIMING BY, THROUGH, UNDER OR AGAINST THE ABOVE NAMED DEFENDANT(S), WHO (IS/ARE) NOT KNOWN TO BE DEAD OR ALIVE, WHETHER SAID UNKNOWN PARTIES CLAIM AS HEIRS, DEVISEES, GRANTEEES, ASSIGNEES, LIENORS, TRUSTEES, SPOUSES, OR OTHER CLAIMANTS; Defendants.

Notice is hereby given that, pursuant to the Summary Final Judgment of Foreclosure entered on January 11, 2012, and the Order Rescheduling Foreclosure Sale entered on February 17, 2014, in this cause, in the Circuit Court of Pasco County, Florida, the clerk shall sell the property situated in Pasco County, Florida, described as:

LOT 51, LESS THE SOUTH 30 FEET THEREOF, AND ALL OF LOT 52, MARTHA'S VINEYARD UNIT FOUR, AC-

CORDING TO THE PLAT THEREOF RECORDED IN PLAT BOOK 7, PAGE 102, OF THE PUBLIC RECORDS OF PASCO COUNTY, FLORIDA. a/k/a 8716 GREEN ST., PORT RICHEY, FL 34668-6021 at public sale, to the highest and best bidder, for cash, online at www.pasco.realforeclose.com, on April 14, 2014 beginning at 11:00 AM.

If you are a person claiming a right to funds remaining after the sale, you must file a claim with the clerk no later than 60 days after the sale. If you fail to file a claim you will not be entitled to any remaining funds.

ANY PERSONS WITH A DISABILITY REQUIRING REASONABLE ACCOMMODATIONS SHOULD CALL NEW PORT RICHEY (813) 847-8110; DADE CITY (352) 521-4274 EXT 8110; TDD 1-800-955-8771 VIA FLORIDA RELAY SERVICE, NO LATER THAN SEVEN (7) DAYS PRIOR TO ANY PROCEEDING.

Dated at St. Petersburg, Florida, this 20th day of March 2014.

By: /s/ Angela L. Leiner, Esquire Angela L. Leiner FBN #85112

Douglas C. Zahm, P.A. Designated Email Address: efling@dczahn.com 12425 28th Street North, Suite 200 St. Petersburg, FL 33716 Telephone No. (727) 536-4911 Attorney for the Plaintiff 665101380 Mar. 28; Apr. 4, 2014 14-01831P

## SECOND INSERTION

NOTICE OF RESCHEDULED SALE IN THE CIRCUIT COURT OF THE SIXTH JUDICIAL CIRCUIT IN AND FOR PASCO COUNTY, FLORIDA CIVIL ACTION

CASE NO.: 51-2007-CA-005234-CAAX-ES HSBC BANK USA, NATIONAL ASSOCIATION AS TRUSTEE FOR THE CERTIFICATEHOLDERS, NOMURA HOME EQUITY LOAN, INC., ASSET-BACKED PASS-THROUGH CERTIFICATES, SERIES 2005-FM1, Plaintiff, vs.

ORTIZ, ELISEO et al, Defendant(s).

NOTICE IS HEREBY GIVEN Pursuant to an Order Rescheduling Foreclosure Sale dated February 27, 2014, and entered in Case No. 51-2007-CA-005234-CAAX-ES of the Circuit Court of the Sixth Judicial Circuit in and for Pasco County, Florida in which Hsbc Bank Usa, National Association As Trustee For The Certificateholders, Nomura Home Equity Loan, Inc., Asset-backed Pass-through Certificates, Series 2005-fm1, is the Plaintiff and Eliseo Ortiz, Khulud Ortiz, are defendants, the Pasco County Clerk of the Circuit Court will sell to the highest and best bidder for cash held online www.pasco.realforeclose.com: in Pasco County, Florida, Pasco County, Florida at 11:00AM on the 14TH day of April, 2014, the following described property as set forth in said Final Judgment of Foreclosure:

BEGIN AT A POINT WHICH 477.34 FEET WEST AND 426.12 FEET NORTH OF THE SOUTHEAST CORNER OF NORTHWEST 1/4 OF THE NORTHWEST 1/4 OF SECTION 4, TOWNSHIP 25 SOUTH, RANGE 21 EAST FOR A POINT OF BEGINNING, THENCE NORTH 60 FEET, THENCE EAST 145.77 FEET, THENCE SOUTH 60 FEET, THENCE 145.77 FEET TO THE POINT OF BEGINNING,

LYING AND BEING IN PASCO COUNTY, FLORIDA. 12810 ANN RD, DADE CITY, FL 33525-8301

Any person claiming an interest in the surplus from the sale, if any, other than the property owner as of the date of the Lis Pendens must file a claim within 60 days after the sale.

If you are a person with a disability who needs an accommodation in order to participate in this proceeding, you are entitled, at no cost to you, to the provision of certain assistance. Please contact:

Public Information Dept., Pasco County Government Center 7530 Little Rd. New Port Richey, FL 34654 Phone: 727.847.8110 (voice) in New Port Richey 352.521.4274, ext 8110 (voice) in Dade City Or 711 for the hearing impaired

Contact should be initiated at least seven days before the scheduled court appearance, or immediately upon receiving this notification if the time before the scheduled appearance is less than seven days.

The court does not provide transportation and cannot accommodate such requests. Persons with disabilities needing transportation to court should contact their local public transportation providers for information regarding transportation services.

Dated in Hillsborough County, Florida, this 19th day of March, 2014

/s/ Erik Del'Etoile Erik Del'Etoile, Esq. FL Bar # 71675

Albertelli Law Attorney for Plaintiff P.O. Box 23028 Tampa, FL 33623 (813) 221-4743 (813) 221-9171 facsimile eService: servealaw@albertellilaw.com BM - 11-68997 Mar. 28; Apr. 4, 2014 14-01787P

## SECOND INSERTION

NOTICE OF SALE IN THE CIRCUIT COURT OF THE SIXTH JUDICIAL CIRCUIT IN AND FOR PASCO COUNTY, FLORIDA CASE NO.

51-2012-CA-004208WS

U.S. BANK NATIONAL ASSOCIATION Plaintiff, v. OLGA L. HINES; UNKNOWN SPOUSE OF OLGA L. HINES; UNKNOWN TENANT 1; UNKNOWN TENANT 2; AND ALL UNKNOWN PARTIES CLAIMING BY, THROUGH, UNDER OR AGAINST THE ABOVE NAMED DEFENDANT(S), WHO (IS/ARE) NOT KNOWN TO BE DEAD OR ALIVE, WHETHER SAID UNKNOWN PARTIES CLAIM AS HEIRS, DEVISEES, GRANTEEES, ASSIGNEES, LIENORS, CREDITORS, TRUSTEES, SPOUSES, OR OTHER CLAIMANTS; THE VERANDAHAS AT PASCO COMMUNITY ASSOCIATION, INC. Defendants.

Notice is hereby given that, pursuant to the Summary Final Judgment of Foreclosure entered on February 27, 2014, in this cause, in the Circuit Court of Pasco County, Florida, the clerk shall sell the property situated in Pasco County, Florida, described as:

LOT NO. 463, VERANDAHAS, ACCORDING TO THE PLAT THEREOF, AS RECORDED IN

PLAT BOOK 56, PAGE 64, OF THE PUBLIC RECORDS OF PASCO COUNTY, FLORIDA. a/k/a 12854 WHITE BLUFF RD., HUDSON, FL 34669-5052

at public sale, to the highest and best bidder, for cash, online at www.pasco.realforeclose.com, on April 15, 2014 beginning at 11:00 AM.

If you are a person claiming a right to funds remaining after the sale, you must file a claim with the clerk no later than 60 days after the sale. If you fail to file a claim you will not be entitled to any remaining funds.

ANY PERSONS WITH A DISABILITY REQUIRING REASONABLE ACCOMMODATIONS SHOULD CALL NEW PORT RICHEY (813) 847-8110; DADE CITY (352) 521-4274 EXT 8110; TDD 1-800-955-8771 VIA FLORIDA RELAY SERVICE, NO LATER THAN SEVEN (7) DAYS PRIOR TO ANY PROCEEDING.

Dated at St. Petersburg, Florida, this 20th day of March 2014.

By: /s/ Angela L. Leiner, Esquire Angela L. Leiner FBN #85112

Douglas C. Zahm, P.A. Designated Email Address: efling@dczahn.com 12425 28th Street North, Suite 200 St. Petersburg, FL 33716 Telephone No. (727) 536-4911 Attorney for the Plaintiff 665120338 Mar. 28; Apr. 4, 2014 14-01826P

## SECOND INSERTION

NOTICE OF SALE IN THE CIRCUIT COURT OF THE SIXTH JUDICIAL CIRCUIT IN AND FOR PASCO COUNTY, FLORIDA CASE NO.: 2008-CA-00619

CHRISTIANA TRUST, A DIVISION OF WILMINGTON SAVINGS FUND SOCIETY, FSB, AS TRUSTEE FOR STANWICH MORTGAGE LOAN TRUST, SERIES 2012-13, Plaintiff, v.

RICHARD KAISER, et al., Defendants.

NOTICE IS HEREBY GIVEN that, pursuant to the Uniform Final Judgment of Foreclosure entered on March 12, 2014 in the above-captioned action, the following property situated in Pasco County, Florida, described as:

LOT 40, BAYHEAD LANDINGS, ACCORDING TO THE MAP OR PLAT THEREOF, AS RECORDED IN PLAT BOOK 29, PAGES 36 THROUGH 38, OF THE PUBLIC RECORDS OF PASCO COUNTY, FLORIDA.

Shall be sold by the Clerk of Court on the 29th day of April, 2014 at 11:00 a.m. (Eastern Time) at www.pasco.realforeclose.com to the highest bidder, for cash, after giving notice as required by section 45.031, Florida Statutes.

Any person claiming an interest in the surplus from the sale, if any, other than the property owner as of the date of the Lis Pendens must file a claim within 60 days after the sale. The court, in its discretion, may enlarge the time

of the sale. Notice of the changed time of sale shall be published as provided herein.

If you are a person with a disability who needs any accommodation in order to participate in this proceeding, you are entitled, at no cost to you to the provision of certain assistance. Within two (2) working days of your receipt of this (describe notice/order) please contact the Public Information Dept., Pasco County Government Center, 7530 Little Rd., New Port Richey, FL 34654; (727) 847-8110 (V) in New Port Richey; (352) 521-4274, ext. 8110 (V) in Dade City; via 1-800-955-8771 if you are hearing impaired. The court does not provide transportation and cannot accommodate for this service. Persons with disabilities needing transportation to court should contact their local public transportation providers for information regarding disabled transportation services.

Dated: March 24, 2014.

CHRISTIAN J. GENDREAU Florida Bar No.: 0620939 SUZANNE V. DELANEY Florida Bar No.: 0957941

STOREY LAW GROUP, P.A. 3191 Maguire Blvd., Suite 257 Orlando, FL 32803 Telephone: (407)488-1225 Primary E-Mail: sdelaney@storeylawgroup.com Secondary E-Mail: slgltigation@storeylawgroup.com Attorneys for Plaintiff Mar. 28; Apr. 4, 2014 14-01845P

## SECOND INSERTION

NOTICE OF FORECLOSURE SALE IN THE CIRCUIT COURT OF THE SIXTH JUDICIAL CIRCUIT IN AND FOR PASCO COUNTY, FLORIDA CIVIL ACTION

CASE NO.: 51-2012-CA-000168WS

DIVISION: J2 WELLS FARGO BANK, NA, Plaintiff, vs.

JEFFREY R. MEYER, et al, Defendant(s).

NOTICE IS HEREBY GIVEN pursuant to a Final Judgment of Mortgage Foreclosure dated March 12, 2014 and entered in Case No. 51-2012-CA-000168WS of the Circuit Court of the SIXTH Judicial Circuit in and for PASCO County, Florida wherein WELLS FARGO BANK, NA is the Plaintiff and JEFFREY R MEYER; THE UNKNOWN SPOUSE OF JEFFREY R. MEYER N/K/A DEBORAH MEYER; KAREN A MALLUCK; JEFFREY R. MEYER AS TRUSTEE OF THE J&K LAND TRUST DATED OCTOBER 11, 2004; THE UNKNOWN BENEFICIARIES OF THE J&K LAND TRUST DATED OCTOBER 11, 2004; ANY AND ALL UNKNOWN PARTIES CLAIMING BY, THROUGH, UNDER, AND AGAINST THE HEREIN NAMED INDIVIDUAL DEFENDANT(S) WHO ARE NOT KNOWN TO BE DEAD OR ALIVE, WHETHER SAID UNKNOWN PARTIES MAY CLAIM AN INTEREST AS SPOUSES, HEIRS, DEVISEES, GRANTEEES, OR OTHER CLAIMANTS; MILLPOND ESTATES SECTION ONE HOMEOWNERS ASSOCIATION, INC.; MILLPOND ESTATES COMMUNITY HOMEOWNERS ASSOCIATION, INC.; TENANT #1 N/K/A ANTHONY GUADALUPE, and TENANT #2 N/K/A LINDA GUADALUPE are the Defendants, The Clerk will sell to the highest and best bidder for cash at WWW.PASCO.REALFORECLOSE.COM IN ACCORDANCE

WITH CHAPTER 45 FLORIDA STATUTES AT 11:00AM, on 05/12/2014, the following described property as set forth in said Final Judgment:

LOT 57, MILLPOND ESTATES, SECTION ONE, ACCORDING TO THE PLAT THEREOF AS RECORDED IN PLAT BOOK 23, PAGE(S) 121 THROUGH 125, OF THE PUBLIC RECORDS OF PASCO COUNTY, FLORIDA. A/K/A 4112 ANDOVER STREET, NEW PORT RICHEY, FL 34653

Any person claiming an interest in the surplus from the sale, if any, other than the property owner as of the date of the Lis Pendens must file a claim within sixty (60) days after the sale.

\*\*See Americans with Disabilities Act

"If you are a person with a disability who needs an accommodation in order to participate in this proceeding, you are entitled, at no cost to you, to the provision of certain assistance. Please contact:

Public Information Dept., Pasco County Government Center 7530 Little Rd. New Port Richey, FL 34654 Phone: 727.847.8110 (voice) in New Port Richey 352.521.4274, ext 8110 (voice) in Dade City Or 711 for the hearing impaired

Contact should be initiated at least seven days before the scheduled court appearance, or immediately upon receiving this notification if the time before the scheduled appearance is less than seven days."

By: Victoria S. Jones Florida Bar No. 52252 Ronald R Wolfe & Associates, P.L. P.O. Box 25018 Tampa, Florida 33622-5018 (813) 251-4766 (813) 251-1541 Fax F11018790

Mar. 28; Apr. 4, 2014 14-01793P

## SECOND INSERTION

NOTICE OF SALE IN THE CIRCUIT COURT OF THE SIXTH JUDICIAL CIRCUIT IN AND FOR PASCO COUNTY, FLORIDA CASE NO.

51-2012-CA-007420ES

WELLS FARGO BANK, N.A. Plaintiff, v. WILLIAM L. CHRISTIE; PAMELA W. CHRISTIE A/K/A PAMELA CHRISTIE; UNKNOWN TENANT 1; UNKNOWN TENANT 2; AND ALL UNKNOWN PARTIES CLAIMING BY, THROUGH, UNDER OR AGAINST THE ABOVE NAMED DEFENDANT(S), WHO (IS/ARE) NOT KNOWN TO BE DEAD OR ALIVE, WHETHER SAID UNKNOWN PARTIES CLAIM AS HEIRS, DEVISEES, GRANTEEES, ASSIGNEES, LIENORS, CREDITORS, TRUSTEES, SPOUSES, OR OTHER CLAIMANTS; LAKE JOVITA HOMEOWNERS ASSOCIATION, INC. Defendants.

Notice is hereby given that, pursuant to the Summary Final Judgment of Foreclosure entered on February 25, 2014, in this cause, in the Circuit Court of Pasco County, Florida, the clerk shall sell the property situated in Pasco County, Florida, described as:

LOT 567, LAKE JOVITA GOLF AND COUNTRY CLUB PHASE THREE-A, ACCORDING TO THE MAP OR PLAT THEREOF, AS RECORDED IN PLAT

BOOK 42, PAGE(S) 133 AND 134, PUBLIC RECORDS OF PASCO COUNTY, FLORIDA. a/k/a 13230 LEGENDS TRAIL, DADE CITY, FL 33525-6238

at public sale, to the highest and best bidder, for cash, online at www.pasco.realforeclose.com, on April 15, 2014 beginning at 11:00 AM.

If you are a person claiming a right to funds remaining after the sale, you must file a claim with the clerk no later than 60 days after the sale. If you fail to file a claim you will not be entitled to any remaining funds.

ANY PERSONS WITH A DISABILITY REQUIRING REASONABLE ACCOMMODATIONS SHOULD CALL NEW PORT RICHEY (813) 847-8110; DADE CITY (352) 521-4274 EXT 8110; TDD 1-800-955-8771 VIA FLORIDA RELAY SERVICE, NO LATER THAN SEVEN (7) DAYS PRIOR TO ANY PROCEEDING.

Dated at St. Petersburg, Florida, this 20th day of March 2014.

By: /s/ Angela L. Leiner, Esquire Angela L. Leiner FBN #85112

Douglas C. Zahm, P.A. Designated Email Address: efling@dczahn.com 12425 28th Street North, Suite 200 St. Petersburg, FL 33716 Telephone No. (727) 536-4911 Attorney for the Plaintiff 888122143 Mar. 28; Apr. 4, 2014 14-01827P

## SECOND INSERTION

NOTICE OF FORECLOSURE SALE IN THE CIRCUIT COURT OF THE SIXTH JUDICIAL CIRCUIT, IN AND FOR PASCO COUNTY, FLORIDA CIVIL DIVISION

CASE NO.: 51-2009-CA-007381-ES

GMAC MORTGAGE, LLC Plaintiff, vs.

ROBERT L. HILL, et al Defendants.

NOTICE IS HEREBY GIVEN pursuant to a Summary Final Judgment of foreclosure dated February 19, 2014, and entered in Case No. 51-2009-CA-007381-ES of the Circuit Court of the SIXTH Judicial Circuit in and for PASCO COUNTY, Florida, wherein GMAC MORTGAGE, LLC, is Plaintiff, and ROBERT L. HILL, et al are Defendants, the clerk will sell to the highest and best bidder for cash, beginning at 11:00 AM at www.pasco.realforeclose.com, in accordance with Chapter 45, Florida Statutes, on the 21 day of April, 2014, the following described property as set forth in said Summary Final Judgment, to wit:

LOT 9, BLOCK 3, MEADOW POINTE PARCEL 17, UNIT 2, ACCORDING TO THE MAP OR PLAT THEREOF, AS RECORDED IN PLAT BOOK 37, PAGE 81, OF THE PUBLIC RECORDS OF PASCO COUNTY, FLORIDA.

Any person claiming an interest in the surplus funds from the sale, if any, other than the property owner as of the date of the lis pendens must file a claim within 60 days after the sale.

If you are a person with a disability

who needs any accommodation in order to participate in this proceeding, you are entitled, at no cost to you, to the provision of certain assistance. Please contact the Public Information Dept., Pasco County Government Center, 7530 Little Rd., New Port Richey, FL 34654; (727) 847-8110 (V) in New Port Richey; (352) 521-4274, ext 8110 (V) in Dade City, at least seven (7) days before your scheduled court appearance, or immediately upon receiving this notification if the time before the scheduled appearance is less than seven (7) days; if you are hearing or voice impaired, call 711.

The court does not provide transportation and cannot accommodate for this service. Persons with disabilities needing transportation to court should contact their local public transportation providers for information regarding transportation services.

Dated: March 24, 2014

By: /s/ Heather J. Koch Phelan Hallinan, PLC Heather J. Koch, Esq., Florida Bar No. 89107 Emilio R. Lenzi, Esq., Florida Bar No. 0668273

Phelan Hallinan, PLC Attorneys for Plaintiff 2727 West Cypress Creek Road Ft. Lauderdale, FL 33309 Tel: 954-462-7000 Fax: 954-462-7001 Service by email: FL.Service@PhelanHallinan.com PH # 11276 Mar. 28; Apr. 4, 2014 14-01854P

## SECOND INSERTION

NOTICE OF FORECLOSURE SALE IN THE CIRCUIT COURT OF THE 6TH JUDICIAL CIRCUIT, IN AND FOR PASCO COUNTY, FLORIDA CIVIL DIVISION:

CASE NO.: 512012CA2477-WS

H&R BLOCK BANK, FSB, Plaintiff, vs.

TIBOR CSUHAJ; ROSEWOOD AT RIVER

RIDGE HOMEOWNERS' ASSOCIATION, INC.; SAND CANYON CORPORATION F/K/A

OPTION ONE MORTGAGE CORPORATION; MONIKA

PETO; UNKNOWN TENANT IN

POSSESSION OF THE SUBJECT

PROPERTY, Defendants.

NOTICE IS HEREBY GIVEN pursuant to Final Judgment of Foreclosure dated the 29th day of January, 2014, and entered in Case No. 512012CA2477-WS, of the Circuit Court of the 6TH Judicial Circuit in and for Pasco County, Florida, wherein H&R BLOCK BANK, FSB is the Plaintiff and TIBOR CSUHAJ; ROSEWOOD AT RIVER RIDGE HOMEOWNERS' ASSOCIATION, INC.; SAND CANYON CORPORATION F/K/A OPTION ONE MORTGAGE CORPORATION; MONIKA PETO and UNKNOWN TENANT(S) IN POSSESSION OF THE SUBJECT PROPERTY are defendants. The Clerk of this Court shall sell to the highest and best bidder for cash, on the 22nd day of April, 2014, at 11:00 AM on Pasco County's Public Auction website: www.pasco.realforeclose.com, pursuant to judgment or order of the Court, in accordance with Chapter 45, Florida Statutes, the following described property as set forth in said Final Judgment, to wit:

LOT 125, ROSEWOOD AT RIVER RIDGE PHASE 1, ACCORDING TO THE PLAT OR MAP THEREOF, AS RECORDED

ED IN PLAT BOOK 29, PAGES 22 THROUGH 25, PUBLIC RECORDS OF PASCO COUNTY, FLORIDA

ANY PERSON CLAIMING AN INTEREST IN THE SURPLUS FROM THE SALE, IF ANY, OTHER THAN THE PROPERTY OWNER AS OF THE DATE OF THE LIS PENDENS MUST FILE A CLAIM WITHIN 60 DAYS AFTER THE SALE.

If you are a person with a disability who needs any accommodation in order to participate in this proceeding, you are entitled, at no cost to you, to the provision of certain assistance. Please contact the Public Information Dept., Pasco County Government Center, 7530 Little Rd., New Port Richey, FL 34654; (727) 847-8110 (V) in New Port Richey; (352) 521-4274, ext 8110 (V) in Dade City, at least 7 days before your scheduled court appearance, or immediately upon receiving this notification if the time before the scheduled appearance is less than 7 days; if you are hearing impaired call 711. The court does not provide transportation and cannot accommodate for this service. Persons with disabilities needing transportation to court should contact their local public transportation providers for information regarding transportation services.

Dated this 24 day of March, 2014.

By: Jennifer Nicole Tarquinio Bar #99192

Submitted by: Choice Legal Group, P.A. P.O. Box 9908 Fort Lauderdale, FL 33310-9908 Telephone: (954) 453-0365 Facsimile: (954) 771-6052 Toll Free: 1-800-441-2438 DESIGNATED PRIMARY E-MAIL FOR SERVICE PURSUANT TO FLA. R. JUD. ADMIN 2.516 eService@clelegalgroup.com 10-29789 Mar. 28; Apr. 4, 2014 14-01840P

## SECOND INSERTION

NOTICE OF FORECLOSURE SALE IN THE CIRCUIT COURT OF THE SIXTH JUDICIAL CIRCUIT IN AND FOR PASCO COUNTY, FLORIDA GENERAL JURISDICTION DIVISION

**CASE NO. 2010-CA-007103-WS DEUTSCHE BANK NATIONAL TRUST COMPANY AS TRUSTEE FOR LONG BEACH MORTGAGE LOAN TRUST 2004-3, ASSET-BACKED CERTIFICATES, SERIES 2004-3, Plaintiff, vs. CRYSTAL L. THIBODEAUX A/K/A CRYSTAL LYNN THIBODEAUX F/K/A CRYSTAL L. HOLLON, et al. Defendant(s).** NOTICE IS HEREBY GIVEN pursuant to a Final Judgment of Foreclosure dated August 28, 2013, and entered in 2010-CA-007103-WS of the Circuit Court of the Sixth Judicial Circuit in and for Pasco County, Florida, wherein DEUTSCHE BANK NATIONAL TRUST COMPANY AS TRUSTEE FOR LONG BEACH

MORTGAGE LOAN TRUST 2004-3, ASSET-BACKED CERTIFICATES, SERIES 2004-3, is the Plaintiff and CRYSTAL L. THIBODEAUX A/K/A CRYSTAL LYNN THIBODEAUX F/K/A CRYSTAL L. HOLLON; BENEFICIAL FLORIDA INC; WILHELMINA A GAMMON; GLENN E. THIBODEAUX; UNKNOWN TENANTS are the Defendant(s). Paula O'Neil as the Clerk of the Circuit Court will sell to the highest and best bidder for cash, www.pasco.realforeclose.com, at 11:00 AM on April 9, 2014, the following described property as set forth in said Final Judgment, to wit:

LOT 103 AND 104, ANCLOTE RIVER ACRES, UNIT THREE, ACCORDING TO THE MAP OR PLAT THEREOF, AS RECORDED IN PLAT BOOK 4, PAGE 70, OF THE PUBLIC RECORDS OF PASCO COUNTY, FLORIDA.

Any person claiming an interest in the surplus from the sale, if any, other than the property owner as of the date of the lis pendens must file a claim within 60

days after the sale.

**IMPORTANT**

If you are a person with a disability who needs an accommodation in order to participate in this proceeding, you are entitled, at no cost to you, to the provision of certain assistance. Please contact: Public Information Dept., Pasco County Government Center, 7530 Little Rd., New Port Richey, FL 34654, Phone: 727.847.8110 (voice) in New Port Richey, 352.521.4274, ext 8110 (voice) in Dade City Or 711 for the hearing impaired. Contact should be initiated at least seven days before the scheduled court appearance, or immediately upon receiving this notification if the time before the scheduled appearance is less than seven days. Dated this 20 day of March, 2014.

By: Philip Jones  
Florida Bar: 107721  
Robertson, Anschutz & Schneid, PL  
Attorneys for Plaintiff  
6409 Congress Avenue, Suite 100  
Boca Raton, Florida 33487  
13-13446  
Mar. 28; Apr. 4, 2014 14-01817P

## SECOND INSERTION

NOTICE OF FORECLOSURE SALE IN THE CIRCUIT COURT OF THE 6TH JUDICIAL CIRCUIT, IN AND FOR PASCO COUNTY, FLORIDA.

**CASE NO. 51-2012-CA-007142-WS DEUTSCHE BANK NATIONAL TRUST COMPANY AS TRUSTEE FOR J. P. MORGAN MORTGAGE ACQUISITION TRUST 2007-CH1, ASSET BACKED PASS-THROUGH CERTIFICATES, SERIES 2007-CH1, Plaintiff, vs. HOY JR, HARVEY, et al., Defendants.**

NOTICE IS HEREBY GIVEN pursuant to an Order or Final Judgment entered in Case No. 51-2012-CA-007142-WS of the Circuit Court of the 6TH Judicial Circuit in and for PASCO County, Florida, wherein, DEUTSCHE BANK NATIONAL TRUST COMPANY AS TRUSTEE FOR J. P. MORGAN MORTGAGE ACQUISITION TRUST 2007-CH1, ASSET BACKED PASS-THROUGH CERTIFICATES, SERIES 2007-CH1, Plaintiff, and, HOY JR,

HARVEY, et al., are Defendants, the Clerk of Court will sell to the highest bidder for cash at, WWW.PASCO.REALFORECLOSE.COM, at the hour of 11:00 A.M., on the 15th day of APRIL, 2014, the following described property: LOT 1139, SEVEN SPRINGS HOMES, UNIT 5-B, PHASE 2, ACCORDING TO MAP OR PLAT THEREOF AS RECORDED IN PLAT BOOK 17, PAGE 1 THRU 3, PUBLIC RECORDS OF PASCO COUNTY, FLORIDA PARCEL # 22-26-004G-00001-1390

Any person claiming an interest in the surplus from the sale, if any, other than the property owner as of the date of the lis pendens, must file a claim within 60 days after the sale.

**IMPORTANT**

If you are a person with a disability who needs any accommodation in order to participate in this proceeding, you are entitled, at no cost to you, to the provision of certain assistance. Please contact the Clerk of the Courts

disability coordinator at PUBLIC INFORMATION DEPARTMENT, PASCO COUNTY GOVERNMENT CENTER, 7530 LITTLE ROAD, NEW PORT RICHEY, FL 34654 - , 727-847-8110. at least 7 days before your scheduled court appearance, or immediately upon receiving this notification if the time before the scheduled appearance is less than 7 days; if you are hearing or voice impaired, call 711.

DATED this 20 day of March, 2014.  
By: Adi M. Reinstein, Esq  
Florida Bar No.: 41992  
GREENSPOON MARDER, P.A.  
TRADE CENTRE SOUTH,  
SUITE 700  
100 WEST CYPRESS CREEK ROAD  
FORT LAUDERDALE, FL 33309  
Telephone: (954) 343 6273  
Hearing Line: (888) 491-1120  
Facsimile: (954) 343 6982  
Email:  
adi.reinstein@gmlaw.com  
Email 2: gmforeclosure@gmlaw.com  
(25963.2104)  
Mar. 28; Apr. 4, 2014 14-01819P

## SECOND INSERTION

NOTICE OF FORECLOSURE SALE IN THE CIRCUIT COURT OF THE SIXTH JUDICIAL CIRCUIT OF FLORIDA IN AND FOR PASCO COUNTY GENERAL JURISDICTION DIVISION

**CASE NO. 51-2010-CA-006696-XXXX-WS BRANCH BANKING AND TRUST COMPANY, Plaintiff, vs. MARK S SALGUEIRO, et al., Defendants.**

NOTICE IS HEREBY GIVEN pursuant to a Summary Final Judgment of Foreclosure entered May 29, 2013 in Civil Case No. 51-2010-CA-006696-XXXX-WS of the Circuit Court of the SIXTH Judicial Circuit in and for Pasco County, Dade City, Florida, wherein BRANCH BANKING AND TRUST COMPANY is Plaintiff and MARK S SALGUEIRO, GLORIA SALGUEIRO, HARBOR VILLAS CONDOMINIUM ASSOCIATION, INC, UNKNOWN TENANT #1 N/K/A ANGEL MUNET, UNKNOWN TENANT #2 are Defendants, the Clerk of Court will sell to the highest and best bidder for cash electronically at www.pasco.realforeclose.com in accordance with Chapter 45, Florida Statutes on the 15th day of April, 2014 at 11:00 AM on the following described property as set forth in said Summary Final Judgment, to-wit:

Unit Number 103, Building 100, Harbor Villas Condominium, Phase Three, according to the Declaration of Condominium thereof and a percentage in the common elements appurtenant thereto as recorded in O.R. Book 930, Page(s) 1743, and subsequent amendments thereto,

and as recorded in Plat Book 18, Page(s) 28 and 29, of the Public Records of Pasco County, Florida.

Any person claiming an interest in the surplus from the sale, if any, other than the property owner as of the date of the lis pendens, must file a claim within 60 days after the sale.

If you are a person with a disability who needs any accommodation in order to participate in this proceeding, you are entitled, at no cost to you, to the provision of certain assistance. Please contact the Public Information Dept., Pasco County Government Center, 7530 Little Rd., New Port Richey, FL 34654; (727) 847-8110 (V) in New Port Richey; (352) 521-4274, ext 8110 (V) in Dade City, at least 7 days before your scheduled court appearance, or immediately upon receiving this notification if the time before the scheduled appearance is less than 7 days; if you are hearing impaired call 711. The court does not provide transportation and cannot accommodate for this service. Persons with disabilities needing transportation to court should contact their local public transportation providers for information regarding transportation services.

Allyson G Morgado  
FL Bar # 91506  
for Marie D. Campbell, Esq.  
Fla. Bar No.: 54337  
McCalla Raymer, LLC  
Attorney for Plaintiff  
225 E. Robinson St. Suite 660  
Orlando, FL 32801  
Phone: (407) 674-1850  
Fax: (321) 248-0420  
Email:  
MRSservice@mccallarayer.com  
2568741  
11-03714-5  
Mar. 28; Apr. 4, 2014 14-01803P

## SECOND INSERTION

RE-NOTICE OF FORECLOSURE SALE IN THE CIRCUIT COURT OF THE SIXTH JUDICIAL CIRCUIT IN AND FOR PASCO COUNTY, FLORIDA

**CASE NO.: 51-2009-CA-009231-ES (J4) FEDERAL NATIONAL MORTGAGE ASSOCIATION, Plaintiff, vs. LUIS E. PORTELA, ERADY C. PORTELA, MORTGAGE ELECTRONIC REGISTRATION SYSTEMS INC., SKINNER NURSERIES, INC, OAK CREEK OF PASCO COUNTY HOMEOWNERS' ASSOCIATION, INC., UNKNOWN TENANT #1, UNKNOWN TENANT #2, and ALL OTHER UNKNOWN PARTIES, et al., Defendant(s).**

NOTICE IS HEREBY GIVEN pursuant to a Final Summary Judgment of Foreclosure dated October 16, 2012 and an Order Rescheduling Foreclosure Sale dated March 6, 2014, entered in Civil Case No.: 51-2009-CA-009231-ES (J4) of the Circuit Court of the Sixth Judicial Circuit in and for Pasco County, Florida, wherein FEDERAL NATIONAL MORTGAGE ASSOCIATION, Plaintiff, and LUIS E. PORTELA, ERADY C. PORTELA, MORTGAGE ELECTRONIC REGISTRATION SYSTEMS INC., SKINNER NURSERIES, INC, OAK CREEK OF PASCO COUNTY HOMEOWNERS' ASSOCIATION, INC., are Defendants.

PAULA S. O'NEIL, The Clerk of the Circuit Court, will sell to the highest bidder for cash, www.pasco.realforeclose.com, at 11:00 AM, on the 15th day of April, 2014, the following described real property as set forth in said Final Summary Judgment,

to wit:  
LOT 209, OAK CREEK PHASE ONE, AS PER PLAT THEREOF, RECORDED IN PLAT BOOK 53, PAGES 40 THROUGH 52, OF THE PUBLIC RECORDS OF PASCO COUNTY, FLORIDA.

If you are a person claiming a right to funds remaining after the sale, you must file a claim with the clerk no later than 60 days after the sale. If you fail to file a claim you will not be entitled to any remaining funds. After 60 days, only the owner of record as of the date of the lis pendens may claim the surplus.

IF YOU ARE A PERSON WITH A DISABILITY WHO NEEDS ANY ACCOMMODATION IN ORDER TO PARTICIPATE IN THIS PROCEEDING, YOU ARE ENTITLED, AT NO COST TO YOU, TO THE PROVISION OF CERTAIN ASSISTANCE. WITHIN TWO (2) WORKING DAYS OF YOUR RECEIPT OF THIS NOTICE, PLEASE CONTACT THE CLERK OF THE CIRCUIT COURT, (727) 847-8176), 7530 LITTLE ROAD, NEW PORT RICHEY, FL 34654, OR IF HEARING IMPAIRED, 1-800-955-8771 (TDD); OR 1-800-955-8770 (V) VIA FLORIDA RELAY SERVICE.

Dated: 3/19/14  
By: Evan Fish  
Florida Bar No.: 102612  
Florida Bar No.: 51323  
Attorney for Plaintiff:  
Brian L. Rosaler, Esquire  
Popkin & Rosaler, P.A.  
1701 West Hillsboro Boulevard;  
Suite 400  
Deerfield Beach, FL 33442  
Telephone: (954) 360-9030  
Facsimile: (954) 420-5187  
11-28138  
Mar. 28; Apr. 4, 2014 14-01805P

## SECOND INSERTION

NOTICE OF FORECLOSURE SALE IN THE CIRCUIT COURT OF THE 6TH JUDICIAL CIRCUIT IN AND FOR PASCO COUNTY, FLORIDA

**CASE NO.: 51-2010-CA-008007-WS-J3 WELLS FARGO BANK, N.A., ALSO KNOWN AS WACHOVIA MORTGAGE, A DIVISION OF WELLS FARGO BANK, N.A., FORMERLY KNOWN AS WACHOVIA MORTGAGE, FSB, FORMERLY KNOWN AS WORLD SAVINGS BANK, FSB, Plaintiff, vs. JOHN W. BURKETT, JR., DIANA BURKETT, LAKESIDE WOODLANDS CIVIC ASSOCIATION, INC, Defendants.**

NOTICE IS HEREBY GIVEN pursuant to an Order to Reschedule Foreclosure sale dated March 4, 2014 and entered in Case No. 51-2010-CA-008007-WS-J3 of the Circuit Court of the 6th Judicial Circuit, in and for Pasco County, Florida, wherein the Clerk of the Court shall offer for sale to the highest bidder for cash on APRIL 9, 2014 at 11:00 A.M., at www.pasco.realforeclose.com, the following described property as set forth in said Summary Final Judgment lying and being situate in PASCO County, Florida, to wit:

Lot 261, LAKESIDE WOODLANDS SECTION IV, according to map or plat thereof as recorded in Plat Book 22, Page 138, Public Records of Pasco County, Florida.  
Property Address: 8052 Woodbrook Court, Hudson, FL 34667  
ANY PERSON CLAIMING AN INTEREST IN THE SURPLUS FROM THE SALE, IF ANY, OTHER THAN THE PROPERTY OWNER AS OF

THE DATE OF THE LIS PENDENS MUST FILE A CLAIM WITHIN 60 DAYS AFTER THE SALE. THE CLERK SHALL RECEIVE A SERVICE CHARGE OF UP TO \$70 FOR SERVICES IN MAKING, RECORDING, AND CERTIFYING THE SALE AND TITLE THAT SHALL BE ASSESSED AS COSTS. THE COURT, IN ITS DISCRETION, MAY ENLARGE THE TIME OF THE SALE. NOTICE OF THE CHANGED TIME OF SALE SHALL BE PUBLISHED AS PROVIDED HEREIN.

If you are a person with a disability who needs any accommodation in order to participate in this proceeding, you are entitled, at no cost to you, to the provision of certain assistance. Please contact the Public Information Dept., Pasco County Government Center, 7530 Little Rd., New Port Richey, FL 34654; (727) 847-8110 (V) in New Port Richey; (352) 521-4274, ext 8110 (V) in Dade City, at least 7 days before your scheduled court appearance, or immediately upon receiving this notification if the time before the scheduled appearance is less than 7 days; if you are hearing impaired call 711.

The court does not provide transportation and cannot accommodate for this service. Persons with disabilities needing transportation to court should contact their local public transportation providers for information regarding transportation services.

DATED this 19 day of March, 2014 .  
By: Arnold M. Straus Jr. Esq.  
Florida Bar No. 275328  
STRAUS & EISLER, P.A.  
Attorneys for Plaintiff  
10081 Pines Blvd, Suite C  
Pembroke Pines, FL 33024  
954-431-2000  
Mar. 28; Apr. 4, 2014 14-01818P

## SECOND INSERTION

NOTICE OF FORECLOSURE SALE IN THE CIRCUIT COURT OF THE 6TH JUDICIAL CIRCUIT, IN AND FOR PASCO COUNTY, FLORIDA CIVIL DIVISION:

**CASE NO.: 512012CA001582XXXXES WELLS FARGO BANK, N.A., Plaintiff, vs. BENITO MARTINEZ A/K/A BENITO MARTINEZ-REYES; ASHTON OAKS HOMEOWNERS' ASSOCIATION, INC.; ROSA MARIA MARTINEZ; UNKNOWN TENANT IN POSSESSION OF THE SUBJECT PROPERTY, Defendants.**

NOTICE IS HEREBY GIVEN pursuant to Final Judgment of Foreclosure dated the 18th day of December, 2013, and entered in Case No. 512012CA001582XXXXES, of the Circuit Court of the 6TH Judicial Circuit in and for Pasco County, Florida, wherein WELLS FARGO BANK, N.A. is the Plaintiff and BENITO MARTINEZ A/K/A BENITO MARTINEZ-REYES; ASHTON OAKS HOMEOWNERS' ASSOCIATION, INC.; ROSA MARIA MARTINEZ and UNKNOWN TENANT (S) IN POSSESSION OF THE SUBJECT PROPERTY are defendants. The Clerk of this Court shall sell to the highest and best bidder for cash, on the 17th day of April, 2014, at 11:00 AM on Pasco County's Public Auction website: www.pasco.realforeclose.com, pursuant to judgment or order of the Court, in accordance with Chapter 45, Florida Statutes, the following described property as set forth in said Final Judgment, to wit:

LOT 66, ASHTON OAKS SUBDIVISION PHASE I, ACCORDING TO THE MAP OR PLAT THEREOF, AS RECORDED IN PLAT BOOK 62, PAGES 47

THROUGH 56, INCLUSIVE, PUBLIC RECORDS OF PASCO COUNTY, FLORIDA.

ANY PERSON CLAIMING AN INTEREST IN THE SURPLUS FROM THE SALE, IF ANY, OTHER THAN THE PROPERTY OWNER AS OF THE DATE OF THE LIS PENDENS MUST FILE A CLAIM WITHIN 60 DAYS AFTER THE SALE.

If you are a person with a disability who needs any accommodation in order to participate in this proceeding, you are entitled, at no cost to you, to the provision of certain assistance. Please contact the Public Information Dept., Pasco County Government Center, 7530 Little Rd., New Port Richey, FL 34654; (727) 847-8110 (V) in New Port Richey; (352) 521-4274, ext 8110 (V) in Dade City, at least 7 days before your scheduled court appearance, or immediately upon receiving this notification if the time before the scheduled appearance is less than 7 days; if you are hearing impaired call 711. The court does not provide transportation and cannot accommodate for this service. Persons with disabilities needing transportation to court should contact their local public transportation providers for information regarding transportation services.

Dated this 19 day of March, 2014.  
By: Jennifer Nicole Tarquinio  
Bar #99192

Submitted by:  
Choice Legal Group, P.A.  
1800 NW 49th Street, Suite 120  
Fort Lauderdale, Florida 33309  
Telephone: (954) 453-0365  
Facsimile: (954) 771-6052  
Toll Free: 1-800-441-2438  
DESIGNATED PRIMARY E-MAIL FOR SERVICE PURSUANT TO FLA. R. JUD. ADMIN 2.516  
eservice@clelegalgroup.com  
11-19964  
Mar. 28; Apr. 4, 2014 14-01800P

## SECOND INSERTION

NOTICE OF FORECLOSURE SALE IN THE CIRCUIT COURT OF THE 6TH JUDICIAL CIRCUIT IN AND FOR PASCO COUNTY, FLORIDA CIVIL DIVISION

**CASE NO: 51-2009-CA-006385-XXXX-WS BANK OF AMERICA, N.A., Plaintiff, vs. CARLO J. BUONSANTO, et al. Defendants.**

NOTICE IS HEREBY GIVEN pursuant to an Order Resetting the Foreclosure Sale dated March 11, 2014, entered in Civil Case No.: 51-2009-CA-006385-XXXX-WS of the 6th Judicial Circuit in Dade City, Pasco County, Florida, Paula S. O'Neil, the Clerk of the Court, will sell to the highest and best bidder for cash online at www.pasco.realforeclose.com at 11:00 A.M. EST on the 10th day of April, 2014 the following described property as set forth in said Final Judgment, to-wit:

LOT 317 HERITAGE VILLAGE SUBDIVISION UNIT 1, AS RECORDED IN PLAT BOOK 9, PAGE 27 OF THE PUBLIC RECORDS OF PASCO COUNTY, FLORIDA, LESS THE FOLLOWING DESCRIBED PORTION THEREOF, COMMENCE AT THE MOST SOUTHERLY CORNER OF SAID LOT 317 FOR A POINT OF BEGINNING THENCE RUN ALONG THE SOUTHWESTERLY BOUNDARY LINE OF SAID LOT 317, N60°32'17"W, A DISTANCE OF 90.00" TO THE MOST WESTERLY CORNER OF SAID LOT 317; THENCE ALONG THE NORTHWESTERLY BOUNDARY LINE OF SAID LOT 317, N29°27'43"E, A DISTANCE OF 4.58" THENCE S60°32'17"E A DISTANCE OF 90.00" TO THE SOUTHEASTERLY BOUND-

ARY LINE OF SAID LOT 317; THENCE ALONG THE SOUTHEASTERLY BOUNDARY LINE OF SAID LOT 317, S29°27'43" W, A DISTANCE OF 4.58" TO THE POINT OF BEGINNING.

Any person claiming an interest in the surplus from the sale, if any, other than the property owner as of the date of the lis pendens, must file a claim with the clerk of court within 60 days after the sale.

IF YOU ARE A PERSON WITH A DISABILITY WHO NEEDS AN ACCOMMODATION IN ORDER TO PARTICIPATE IN THIS PROCEEDING, YOU ARE ENTITLED, AT NO COST TO YOU, TO THE PROVISION OF CERTAIN ASSISTANCE. PLEASE CONTACT: PUBLIC INFORMATION DEPT., PASCO COUNTY GOVERNMENT CENTER, 7530 LITTLE RD., NEW PORT RICHEY, FL 34654 - PHONE: 727.847.8110 (VOICE) IN NEW PORT RICHEY, 352.521.4274, EXT 8110 (VOICE) IN DADE CITY OR 711 FOR THE HEARING IMPAIRED CONTACT SHOULD BE INITIATED AT LEAST SEVEN DAYS BEFORE THE SCHEDULED COURT APPEARANCE, OR IMMEDIATELY UPON RECEIVING THIS NOTIFICATION IF THE TIME BEFORE THE SCHEDULED APPEARANCE IS LESS THAN SEVEN DAYS.

Dated this 19th day of March, 2014.  
/s/ Maria Fernandez-Gomez  
By: Maria Fernandez-Gomez, Esq.  
Fla. Bar No. 998494  
TRIPP SCOTT, P.A.  
Attorneys for Plaintiff  
110 S.E. Sixth St., 15th Floor  
Fort Lauderdale, FL 33301  
Telephone (954) 765-2999  
Facsimile (954) 761-8475  
Email: mfg@trippscott.com  
11-008675  
Mar. 28; Apr. 4, 2014 14-01802P

## SECOND INSERTION

NOTICE OF FORECLOSURE SALE IN THE CIRCUIT COURT OF THE SIXTH JUDICIAL CIRCUIT IN AND FOR PASCO COUNTY, FLORIDA CIVIL DIVISION

**Case No.: 51-2012-CA-008093WS Division: J2**

**BANK OF AMERICA, N.A. Plaintiff, v. JAMES A. MOULTON; ET AL. Defendants,**

NOTICE IS HEREBY GIVEN pursuant to a Final Judgment dated February 18, 2014, entered in Civil Case No.: 51-2012-CA-008093WS, DIVISION: J2, of the Circuit Court of the SIXTH Judicial Circuit in and for Pasco County, Florida, wherein NATIONSTAR MORTGAGE LLC is Plaintiff, and JAMES A. MOULTON; UNKNOWN SPOUSE OF JAMES A. MOULTON; STATE OF FLORIDA, DEPARTMENT OF REVENUE; CLERK OF COURT, PASCO COUNTY, FLORIDA; UNKNOWN TENANT #1; UNKNOWN TENANT #2; ALL OTHER UNKNOWN PARTIES CLAIMING INTERESTS BY, THROUGH, UNDER, AND AGAINST A NAMED DEFENDANT(S) WHO ARE NOT KNOWN TO BE DEAD OR ALIVE, WHETHER SAME UNKNOWN PARTIES MAY CLAIM AN INTEREST AS SPOUSES, HEIRS, DEVISEES, GRANTEEES, OR OTHER CLAIMANTS, are Defendant(s).

PAULA S. O'NEIL, Clerk of the Court, will sell to the highest bidder for cash at 11:00 a.m. online at www.pasco.realforeclose.com on the 11th day of April, 2014 the following described real property as set forth in said Final Summary Judgment, to wit:  
LOT 10, BLOCK 22, LEXINGLOT 140, VENICE ESTATES, SUBDIVISION, FIRST ADDITION, ACCORDING TO THE MAP OR PLAT THEREOF, AS

RECORDED IN PLAT BOOK 15, PAGE 59, OF THE PUBLIC RECORDS OF PASCO COUNTY, FLORIDA.

If you are a person claiming a right to funds remaining after the sale, you must file a claim with the clerk no later than 60 days after the sale. If you fail to file a claim you will not be entitled to any remaining funds. After 60 days, only the owner of record as of the date of the lis pendens may claim the surplus.

IN ACCORDANCE WITH THE AMERICANS WITH DISABILITIES ACT, If you are a person with a disability who needs any accommodation in order to participate in this proceeding, you are entitled at no cost to you, to the provision of certain assistance. Please contact: Public Information Dept., Pasco County Government Center, 7530 Little Rd., New Port Richey, FL 34654; (727) 847-8110 (voice) for proceedings in New Port Richey; (352) 521-4274, ext 8110 (voice) for proceedings in Dade City at least 7 days before your scheduled court appearance, or immediately upon receiving this notification if the time before the scheduled appearance is less than 7 days; if you are hearing or voice impaired, call 711.

Dated this 17 day of March, 2014.  
/s/ Joshua Sabet  
By: Joshua Sabet, Esquire  
Fla. Bar No.: 85356  
Primary Email:  
JSabet@ErwLaw.com  
Secondary Email:  
docservice@erwlaw.com  
Attorney for Plaintiff:  
Elizabeth R. Wellborn, P.A.  
350 Jim Moran Blvd. Suite 100  
Deerfield Beach, FL 33442  
Telephone: (954) 354-3544  
Facsimile: (954) 354-3545  
FILE # 8377ST-4147  
Mar. 28; Apr. 4, 2014 14-01816P



SECOND INSERTION

NOTICE OF SALE IN THE CIRCUIT COURT OF THE SIXTH JUDICIAL CIRCUIT IN AND FOR PASCO COUNTY, FLORIDA CASE NO.

51-2010-CA-001994WS U.S. BANK, N.A. Plaintiff, v. IVAN TOLEDO; UNKNOWN SPOUSE OF IVAN TOLEDO; UNKNOWN TENANT 1; UNKNOWN TENANT 2; AND ALL UNKNOWN PARTIES CLAIMING BY, THROUGH, UNDER OR AGAINST THE ABOVE NAMED DEFENDANT(S), WHO (IS/ARE) NOT KNOWN TO BE DEAD OR ALIVE, WHETHER SAID UNKNOWN PARTIES CLAIM AS HEIRS, DEVISEES, GRANTEEES, ASSIGNEES, LIENORS, CREDITORS, TRUSTEES, SPOUSES, OR OTHER CLAIMANTS; Defendants. Notice is hereby given that, pursuant to the Summary Final Judgment of Foreclosure entered on February 27, 2014, in this cause, in the Circuit Court of Pasco County, Florida, the clerk shall sell the property situated in Pasco County, Florida, described as:

LOT 117, REGENCY PARK UNIT THREE, ACCORDING TO THE PLAT THEREOF, AS RECORDED IN PLAT BOOK 12, PAGES 12 AND 13, PUBLIC

RECORDS OF PASCO COUNTY, FLORIDA. a/k/a 10038 KINGSWOOD LANE, PORT RICHEY, FL 34668-3723

at public sale, to the highest and best bidder, for cash, online at www.pasco.realforeclose.com, on April 15, 2014 beginning at 11:00 AM.

If you are a person claiming a right to funds remaining after the sale, you must file a claim with the clerk no later than 60 days after the sale. If you fail to file a claim you will not be entitled to any remaining funds.

ANY PERSONS WITH A DISABILITY REQUIRING REASONABLE ACCOMMODATIONS SHOULD CALL NEW PORT RICHEY (813) 847-8110; DADE CITY (352) 521-4274 EXT 8110; TDD 1-800-955-8771 VIA FLORIDA RELAY SERVICE, NO LATER THAN SEVEN (7) DAYS PRIOR TO ANY PROCEEDING.

Dated at St. Petersburg, Florida, this 20th day of March 2014.

By: /s/ Angela L. Leiner, Esquire Angela L. Leiner FBN #85112

Douglas C. Zahm, P.A. Designated Email Address: efling@dczahm.com 12425 28th Street North, Suite 200 St. Petersburg, FL 33716 Telephone No. (727) 536-4911 Attorney for the Plaintiff 665100221 Mar. 28; Apr. 4, 2014 14-01829P

SECOND INSERTION

NOTICE OF SALE IN THE CIRCUIT COURT OF THE SIXTH JUDICIAL CIRCUIT IN AND FOR PASCO COUNTY, FLORIDA CASE NO.

51-2012-CA-008161ES WELLS FARGO BANK, N.A. Plaintiff, v. MARIA M. RODRIGUEZ; UNKNOWN SPOUSE OF MARIA M. RODRIGUEZ; UNKNOWN TENANT 1; UNKNOWN TENANT 2; AND ALL UNKNOWN PARTIES CLAIMING BY, THROUGH, UNDER OR AGAINST THE ABOVE NAMED DEFENDANT(S), WHO (IS/ARE) NOT KNOWN TO BE DEAD OR ALIVE, WHETHER SAID UNKNOWN PARTIES CLAIM AS HEIRS, DEVISEES, GRANTEEES, ASSIGNEES, LIENORS, CREDITORS, TRUSTEES, SPOUSES, OR OTHER CLAIMANTS; Defendants. Notice is hereby given that, pursuant to the Summary Final Judgment of Foreclosure entered on February 25, 2014, in this cause, in the Circuit Court of Pasco County, Florida, the clerk shall sell the property situated in Pasco County, Florida, described as:

LOT 5 AND THE NORTH 25 FEET OF LOT 4, IN BLOCK 2 OF WEST SIDE SUBDIVISION, AS RECORDED IN

PLAT BOOK 3, PAGE 80, OF THE PUBLIC RECORDS OF PASCO COUNTY, FLORIDA. a/k/a 14311 17TH ST, DADE CITY, FL 33523

at public sale, to the highest and best bidder, for cash, online at www.pasco.realforeclose.com, on April 14, 2014 beginning at 11:00 AM.

If you are a person claiming a right to funds remaining after the sale, you must file a claim with the clerk no later than 60 days after the sale. If you fail to file a claim you will not be entitled to any remaining funds.

ANY PERSONS WITH A DISABILITY REQUIRING REASONABLE ACCOMMODATIONS SHOULD CALL NEW PORT RICHEY (813) 847-8110; DADE CITY (352) 521-4274 EXT 8110; TDD 1-800-955-8771 VIA FLORIDA RELAY SERVICE, NO LATER THAN SEVEN (7) DAYS PRIOR TO ANY PROCEEDING.

Dated at St. Petersburg, Florida, this 20th day of March 2014.

By: /s/ Angela L. Leiner, Esquire Angela L. Leiner FBN #85112

Douglas C. Zahm, P.A. Designated Email Address: efling@dczahm.com 12425 28th Street North, Suite 200 St. Petersburg, FL 33716 Telephone No. (727) 536-4911 Attorney for the Plaintiff 888122144 Mar. 28; Apr. 4, 2014 14-01830P

SECOND INSERTION

NOTICE OF FORECLOSURE SALE IN THE CIRCUIT COURT OF THE SIXTH JUDICIAL CIRCUIT IN AND FOR PASCO COUNTY, FLORIDA CASE NO.:

51-2008-CA-007054-W5 DEUTSCHE BANK COMPANY AMERICAS, AS TRUSTEE FOR CERTIFICATE HOLDERS OF BEAR STEARNS ASSET BACKED SECURITIES, INC., ASSET BACKED CERTIFICATES, SERIES 2005-QS16, Plaintiff, -vs.- FREDERICK S. GREENING, ET AL., Defendant(s). NOTICE IS HEREBY GIVEN pursuant to the Final Judgment of Foreclosure dated April 30, 2013 in the above action, the Pasco County Clerk of Court will sell to the highest bidder for cash at Pasco County, Florida, on April 17, 2014, 11:00 AM, at www.pasco.realforeclose.com for the following described property: LOT 1798, COLONIAL HILLS, UNIT 24, ACCORDING TO THE MAP OR PLAT THEREOF, AS RECORDED IN PLAT BOOK 18, PAGE 96 AND 97, OF THE PUBLIC RECORDS OF PASCO COUNTY, FLORIDA.

Any person claiming an interest in the surplus from the sale, if any, other than the property owner as of the date of the lis pendens must file a claim within sixty (60) days after the sale. The Court, in its discretion, may enlarge the time

of the sale. Notice of the changed time of sale shall be published as provided herein.

If you are a person with a disability who needs any accommodation in order to participate in this proceeding, you are entitled, at no cost to you, to the provision of certain assistance. Please contact the Public Information Department at 727-847-8110 (V) in New Port Richey or 352-521-4274, extension 8110 (V) in Dade City or at Pasco County Government Center, 7530 Little Road, New Port Richey, FL 34654 at least 7 days before your scheduled court appearance, or immediately upon receiving this notification if the time before the scheduled appearance is less than 7 days; if you are hearing or voice impaired, call 711. The court does not provide transportation and cannot accommodate such requests. Persons with disabilities needing transportation to court should contact their local public transportation providers for information regarding transportation services.

Elisabeth Porter, Esq. FBN: 645648

Ward, Damon, Posner, Pheterson & Bleau Attorney for Plaintiff 4420 Beacon Circle West Palm Beach, Florida 33407 Tel: (561) 842-3000 Fax: (561) 842-3626 Email: foreclosureservice@warddameron.com Mar. 28; Apr. 4, 2014 14-01844P

SECOND INSERTION

NOTICE OF SALE IN THE CIRCUIT COURT OF THE SIXTH JUDICIAL CIRCUIT IN AND FOR PASCO COUNTY, FLORIDA CASE NO.

51-2011-CA-006267WS U.S. BANK NATIONAL ASSOCIATION SUCCESSOR BY MERGER TO THE LEADER MORTGAGE COMPANY Plaintiff, v. DANIELLE L. BRUYNELL; UNKNOWN SPOUSE OF DANIELLE L. BRUYNELL; UNKNOWN TENANT 1; UNKNOWN TENANT 2; AND ALL UNKNOWN PARTIES CLAIMING BY, THROUGH, UNDER OR AGAINST THE ABOVE NAMED DEFENDANT(S), WHO (IS/ARE) NOT KNOWN TO BE DEAD OR ALIVE, WHETHER SAID UNKNOWN PARTIES CLAIM AS HEIRS, DEVISEES, GRANTEEES, ASSIGNEES, LIENORS, CREDITORS, TRUSTEES, SPOUSES, OR OTHER CLAIMANTS; HOLIDAY LAKE ESTATES CIVIC ASSOCIATION, INC.; HOUSING FINANCE AUTHORITY OF PINELLAS COUNTY, FLORIDA Defendants. Notice is hereby given that, pursuant to the Summary Final Judgment of Foreclosure entered on February 28, 2014, in this cause, in the Circuit Court of Pasco County, Florida, the clerk shall sell the property situated in Pasco County, Florida, described as:

LOT 815, HOLIDAY LAKE ESTATES-UNIT TWELVE,

ACCORDING TO THE MAP OR PLAT THEREOF, AS RECORDED IN PLAT BOOK 10, PAGES 23 AND 24, PUBLIC RECORDS OF PASCO COUNTY, FLORIDA. a/k/a 3235 WELLINGTON DR., HOLIDAY, FL 34691

at public sale, to the highest and best bidder, for cash, online at www.pasco.realforeclose.com, on April 14, 2014 beginning at 11:00 AM.

If you are a person claiming a right to funds remaining after the sale, you must file a claim with the clerk no later than 60 days after the sale. If you fail to file a claim you will not be entitled to any remaining funds.

ANY PERSONS WITH A DISABILITY REQUIRING REASONABLE ACCOMMODATIONS SHOULD CALL NEW PORT RICHEY (813) 847-8110; DADE CITY (352) 521-4274 EXT 8110; TDD 1-800-955-8771 VIA FLORIDA RELAY SERVICE, NO LATER THAN SEVEN (7) DAYS PRIOR TO ANY PROCEEDING.

Dated at St. Petersburg, Florida, this 20th day of March 2014.

By: /s/ Angela L. Leiner, Esquire Angela L. Leiner FBN #85112

Douglas C. Zahm, P.A. Designated Email Address: efling@dczahm.com 12425 28th Street North, Suite 200 St. Petersburg, FL 33716 Telephone No. (727) 536-4911 Attorney for the Plaintiff 665113004 Mar. 28; Apr. 4, 2014 14-01832P

SECOND INSERTION

NOTICE OF FORECLOSURE SALE IN THE CIRCUIT COURT OF THE SIXTH JUDICIAL CIRCUIT IN AND FOR PASCO COUNTY, FLORIDA GENERAL JURISDICTION DIVISION CASE NO. 2013-CA-001643

HOUSEHOLD FINANCE CORP III, Plaintiff, vs. JOHN MCCracken A/K/A JOHN F. MCCracken A/K/A JOHN FRANCIS MCCracken A/K/A JOHN FRANCIS MCCracken A/K/A JOHN FRANCIS MCCracken A/K/A JOHN FRANCIS MCCracken A/K/A JOHN FRANCIS MCCracken A/K/A ANN MARIE MCCracken are the Defendant(s). Paula O'Neil as the Clerk of the Circuit Court will sell to the highest and best bidder for cash, www.pasco.realforeclose.com, at 11:00 AM on April 10, 2014, the following described property as set forth in said Final Judgment, to wit:

LOT 29, LINDA LAKE GROVES, ACCORDING TO THE MAP OR PLAT THEREOF, RECORDED IN PLAT BOOK 12, PAGES 83

THROUGH 86, PUBLIC RECORDS OF PASCO COUNTY, FLORIDA.

Any person claiming an interest in the surplus from the sale, if any, other than the property owner as of the date of the lis pendens must file a claim within 60 days after the sale.

IMPORTANT If you are a person with a disability who needs any accommodation in order to participate in this proceeding, you are entitled, at no cost to you, to the provision of certain assistance. Please contact the Public Information Dept., Pasco County Government Center, 7530 Little Rd., New Port Richey, FL 34654; (727) 847-8110 (V) in New Port Richey; (352) 521-4274, ext 8110 (V) in Dade City, at least 7 days before your scheduled court appearance, or immediately upon receiving this notification if the time before the scheduled appearance is less than 7 days; if you are hearing impaired call 711.

The court does not provide transportation and cannot accommodate for this service. Persons with disabilities needing transportation to court should contact their local public transportation providers for information regarding transportation services.

Dated this 21 day of March, 2014.

By: Philip Jones, Esq. Fla Bar # 107721 Marni Sachs Florida Bar: 92531

Robertson, Anschutz & Schneid, PL Attorneys for Plaintiff 6409 Congress Avenue, Suite 100 Boca Raton, Florida 33487 12-12804 Mar. 28; Apr. 4, 2014 14-01841P

SECOND INSERTION

NOTICE OF FORECLOSURE SALE IN THE CIRCUIT COURT OF THE SIXTH JUDICIAL CIRCUIT OF FLORIDA IN AND FOR PASCO COUNTY GENERAL JURISDICTION DIVISION CASE NO. 2012-CA-000384

OCWEN LOAN SERVICING, LLC, Plaintiff, vs. DEAN O'BRIEN, et al., Defendants.

NOTICE IS HEREBY GIVEN pursuant to a Summary Final Judgment of Foreclosure entered June 3, 2013 in Civil Case No. 2012-CA-000384 of the Circuit Court of the Sixth Judicial Circuit in and for Pasco County, Dade City, Florida, wherein OCWEN LOAN SERVICING, LLC is Plaintiff and DEAN O'BRIEN, RIVERSIDE ESTATES PROPERTY OWNERS ASSOCIATION, UNKNOWN TENANT IN POSSESSION #1, UNKNOWN TENANT IN POSSESSION #2, UNKNOWN SPOUSE OF DEAN O'BRIEN, are Defendants, the Clerk of Court will sell to the highest and best bidder for cash electronically at www.pasco.realforeclose.com in accordance with Chapter 45, Florida Statutes on the 17th day of April, 2014 at 11:00 AM on the following described property as set forth in said Summary Final Judgment, to-wit:

Lot 9, RIVERSIDE ESTATES, according to the plat thereof recorded in Plat Book 40, Pages 59 through 65 inclusive, Public Records of Pasco County, Florida. Any person claiming an interest in the

surplus from the sale, if any, other than the property owner as of the date of the lis pendens, must file a claim within 60 days after the sale.

If you are a person with a disability who needs any accommodation in order to participate in this proceeding, you are entitled, at no cost to you, to the provision of certain assistance. Please contact the Public Information Dept., Pasco County Government Center, 7530 Little Rd., New Port Richey, FL 34654; (727) 847-8110 (V) in New Port Richey; (352) 521-4274, ext 8110 (V) in Dade City, at least 7 days before your scheduled court appearance, or immediately upon receiving this notification if the time before the scheduled appearance is less than 7 days; if you are hearing impaired call 711. The court does not provide transportation and cannot accommodate for this service. Persons with disabilities needing transportation to court should contact their local public transportation providers for information regarding transportation services.

Allyson G Morgado FL Bar # 91506 for Marie D. Campbell, Esq. Fla. Bar No.: 543357

McCalla Raymer, LLC Attorney for Plaintiff 225 E. Robinson St. Suite 660 Orlando, FL 32801 Phone: (407) 674-1850 Fax: (321) 248-0420 Email: MRService@mccallarayer.com 2574391 11-05626-3 Mar. 28; Apr. 4, 2014 14-01842P

SECOND INSERTION

NOTICE OF FORECLOSURE SALE IN THE CIRCUIT COURT OF THE SIXTH JUDICIAL CIRCUIT, IN AND FOR PASCO COUNTY, FLORIDA CIVIL DIVISION CASE NO.

:51-2010-CA-005303-XXXX-ES U.S. BANK NATIONAL ASSOCIATION, AS TRUSTEE FOR J.P. MORGAN MORTGAGE ACQUISITION TRUST 2006-CW1 Plaintiff, vs. KARLA J. TURCOTTE AKA KARLA JUNE TURCOTTE, et. al., Defendants.

NOTICE IS HEREBY GIVEN pursuant to an Order of Final Judgment entered in Case No. 51-2010-CA-005303-XXXX-ES in the Circuit Court of the Sixth Judicial Circuit in and for Pasco County, Florida, wherein, U.S. BANK NATIONAL ASSOCIATION, AS TRUSTEE FOR J.P. MORGAN MORTGAGE ACQUISITION TRUST 2006-CW1, Plaintiff, and, KARLA J. TURCOTTE AKA KARLA JUNE TURCOTTE, et. al., are Defendants. The Clerk of Court will sell to the highest bidder for cash online at www.pasco.realforeclose.com at the hour of 11:00AM, on the 23rd day of April, 2014, the following described property:

LOT 719, LAKE PADGETT ESTATES EAST, BEING MORE PARTICULARLY DESCRIBED AS FOLLOWS: BEGIN AT 1585.42 FEET NORTH AND 872.51 FEET EAST OF THE SOUTHWEST CORNER OF THE NORTHWEST 1/4 OF SECTION 17, TOWNSHIP 26 SOUTH, RANGE 19 EAST; PASCO COUNTY, FLORIDA; RUN SOUTH 01°43' 30" EAST, 90.19 FEET;

THENCE SOUTH 84°35' 40" WEST 125.44 FEET; THENCE NORTH 02°15' 32" WEST, 90.14 FEET; THENCE NORTH 84°35' 40" EAST, 126.28 FEET TO THE POINT OF BEGINNING.

Any person claiming an interest in the surplus from the sale, if any, other than the property owner as of the date of the Lis Pendens must file a claim within 60 days after the sale.

IMPORTANT If you are a person with a disability who needs any accommodation in order to participate in this proceeding, you are entitled, at no cost to you, to the provision of certain assistance. Within two (2) working days of your receipt of this (describe notice/order) please contact the Public Information Dept., Pasco County Government Center, 7530 Little Rd., New Port Richey, FL 34654; (727) 8478110 (V) in New Port Richey; (352) 521-4274, ext. 8110 (V) in Dade City; via 1-800-955-8771 if you are hearing impaired. The court does not provide transportation and cannot accommodate for this service. Persons with disabilities needing transportation to court should contact their local public transportation providers for information regarding disabled transportation services.

DATED this 21 day of March, 2014.

MATTHEW B. KLEIN, ESQ. FL BAR NO. 73529 MILLENNIUM PARTNERS Attorneys for Plaintiff Primary E-Mail Address: service@millenniumpartners.net 14750 NW 77th Court, Suite 303 Telephone: (305) 698-5839 Facsimile: (305) 698-5840 MP# 11-002702 Mar. 28; Apr. 4, 2014 14-01843P

SECOND INSERTION

NOTICE OF FORECLOSURE SALE IN THE CIRCUIT COURT OF THE SIXTH JUDICIAL CIRCUIT IN AND FOR PASCO COUNTY, FLORIDA CASE NO. 2012-CA-005949

REGIONS BANK, SUCCESSOR BY MERGER WITH AMSOUTH BANK, Plaintiff, vs. JOHN L. WHITE, et al., Defendant(s).

NOTICE IS HEREBY GIVEN that pursuant to the Final Judgment of Foreclosure entered on January 29, 2014, in Case No. 2012-CA-005949 of the Circuit Court of the Sixth Judicial Circuit for Pasco County, Florida, in which Regions Bank, Successor by Merger with AmSouth Bank, is Plaintiff, John L. White, et al., are Defendants, I will sell to the highest and best bidder for cash, online via the internet at www.pasco.realforeclose.com, at 11:00am or as soon thereafter as the sale may proceed, on the 29th day of April, 2014, the following described real property as set forth in said Final Judgment, to wit:

A tract of land lying in Section 31, Township 25 South, Range 20 East, Pasco County, Florida, more particularly described as follows: Commencing at the Northeast corner of said Section 31, thence North 88 degrees 50' 27" West, (assumed bearing) a distance of 330.0 feet; thence South 00 degrees 32' 25" East, a distance of 1320.00 feet for a Point of Beginning. Thence continue South 00 degrees 32' 25" East, a distance of 165.00 feet thence North 88 degrees 50' 27" West, a distance of 294.25 feet; thence North 00 degrees 32' 25" West, a distance of 165.00 feet; thence South 88

degrees 50' 27" East, a distance of 294.25 feet, to the Point of Beginning, less the East 30.00 feet thereof for road right of way.

Any person or entity claiming an interest in the surplus, if any, resulting from the foreclosure sale, other than the property owner as of the date of the Lis Pendens, must file a claim on the same with the Clerk of Court within 60 days after the foreclosure sale.

If you are a person with a disability who needs an accommodation in order to participate in this proceeding, you are entitled, at no cost to you, to the provision of certain assistance. Please contact: Public Information Dept., Pasco County Government Center, 7530 Little Rd., New Port Richey, FL 34654; Phone: 727.847.8110 (voice) in New Port Richey, 352.521.4274, ext 8110 (voice) in Dade City, Or 711 for the hearing impaired. Contact should be initiated at least seven days before the scheduled court appearance, or immediately upon receiving this notification if the time before the scheduled appearance is less than seven days. The court does not provide transportation and cannot accommodate such requests. Persons with disabilities needing transportation to court should contact their local public transportation providers for information regarding transportation services.

Sai Kornsuwan, Esq. FBN: 0078266 Mayersohn Law Group, P.A. 101 NE 3rd Ave. Suite 1250 Fort Lauderdale, FL 33301 Telephone: 954-765-1900 / Fax 954-713-0702 Service@mayersohnlaw.com Attorney for Plaintiff File No.: FOR-6629 (Regions/White) Mar. 28; Apr. 4, 2014 14-01852P

SECOND INSERTION

NOTICE OF SALE IN THE CIRCUIT COURT OF THE SIXTH JUDICIAL CIRCUIT IN AND FOR PASCO COUNTY, FLORIDA CIVIL DIVISION CASE #:

51-2012-CA-005701-ES DIVISION: J4

Wells Fargo Bank, N.A. as Trustee of WaMu Mortgage Pass-Through Certificates, Series 2005-PR4 Trust Plaintiff, -vs.- Debra Jew and Raymond Jew, Wife and Husband and Sarah Thomas; JPMorgan Chase Bank, National Association; Stagecoach Property Owners Association, Inc.; Unknown Parties in Possession #1, If living, and all Unknown Parties claiming by, through, under and against the above named Defendant(s) who are not known to be dead or alive, whether said Unknown Parties may claim an interest as Spouse, Heirs, Devisees, Grantees, or Other Claimants; Unknown Parties in Possession #2, If living, and all Unknown Parties claiming by, through, under and against the above named Defendant(s) who are not known to be dead or alive, whether said Unknown Parties may claim an interest as Spouse, Heirs, Devisees, Grantees, or Other Claimants Defendant(s).

NOTICE IS HEREBY GIVEN pursuant to an Order rescheduling foreclosure sale, entered in Civil Case No. 51-2012-CA-005701-ES of the Circuit Court of the 6th Judicial Circuit in and for Pasco County, Florida, wherein Wells Fargo Bank, N.A. as Trustee of WaMu Mortgage Pass-Through Certificates, Series 2005-PR4 Trust, Plaintiff and Debra Jew and Raymond Jew, Wife and Husband and Sarah Thomas

are defendant(s), I, Clerk of Court, Paula S. O'Neil, will sell to the highest and best bidder for cash in an online sale accessed through the Clerk's website at www.pasco.realforeclose.com, at 11:00 a.m. on April 28, 2014, the following described property as set forth in said Final Judgment, to-wit:

LOT 12, BLOCK 2, STAGE-COACH VILLAGE, PARCEL 3, AS PER PLAT THEREOF, RECORDED IN PLAT BOOK 34, PAGE 120, OF THE PUBLIC RECORDS OF PASCO COUNTY, FLORIDA.

ANY PERSON CLAIMING AN INTEREST IN THE SURPLUS FROM THE SALE, IF ANY, OTHER THAN THE PROPERTY OWNER AS OF THE DATE OF THE LIS PENDENS MUST FILE A CLAIM WITHIN 60 DAYS AFTER THE SALE.

If you are a person with a disability who needs any accommodation in order to participate in this proceeding, you are entitled, at no cost to you, to the provision of certain assistance. Please contact the ADA Coordinator; 14250 49th Street North, Clearwater, Florida 33762 (727) 453-7163 at least 7 days before your scheduled court appearance, or immediately upon receiving this notification of the time before the scheduled appearance is less than 7 days. If you are hearing or voice impaired, call 711.

Submitted By: ATTORNEY FOR PLAINTIFF: SHAPIRO, FISHMAN & GACHÉ, LLP 2424 North Federal Highway, Suite 360 Boca Raton, Florida 33431 (561) 998-6700 (561) 998-6707 10-203791 FCOI W50 Mar. 28; Apr. 4, 2014 14-01868P

## SECOND INSERTION

## NOTICE OF RESCHEDULED SALE IN THE CIRCUIT COURT OF THE SIXTH JUDICIAL CIRCUIT IN AND FOR PASCO COUNTY, FLORIDA CIVIL ACTION

**CASE NO.: 51-2012-CA-003276-CAAX-ES GREEN TREE SERVICING LLC, Plaintiff, vs. EPPERT, JOSHUA J. et al, Defendant(s).**  
NOTICE IS HEREBY GIVEN Pursuant to an Order Rescheduling Foreclosure Sale dated on or about February 27, 2014, and entered in Case No. 51-2012-CA-003276-CAAX-ES of the Circuit Court of the Sixth Judicial Circuit in and for Pasco County, Florida in which Green Tree Servicing LLC, is the Plaintiff and Elizabeth A. Jones also known as Elizabeth Ann Jones, Joshua J. Eppert also known as Joshua James Eppert, Mortgage Electronic Registration Systems, Inc., as nominee for First Magnus Financial Corporation, an Arizona Corporation, Tanglewood of Wesley Chapel Home Owners Association, Inc., a dissolved Florida Corporation, are defendants, the Pasco County Clerk of the Circuit Court will sell to the highest and best bidder for cash held online

www.pasco.realforeclose.com: in Pasco County, Florida at 11:00AM on the 16th day of April, 2014, the following described property as set forth in said Final Judgment of Foreclosure:  
LOT 49, OF TANGLEWOOD VILLAGE, PHASE 2, AT WILLIAMSBURG WEST, ACCORDING TO THE MAP OR PLAT THEREOF AS RECORDED IN PLAT BOOK 20, PAGES 134 THROUGH 136, PUBLIC RECORDS OF PASCO COUNTY, FLORIDA.  
1917 TARPON CT, WESLEY CHAPEL, FL 33543-5333  
Any person claiming an interest in the surplus from the sale, if any, other than the property owner as of the date of the Lis Pendens must file a claim within 60 days after the sale.  
If you are a person with a disability who needs an accommodation in order to participate in this proceeding, you are entitled, at no cost to you, to the provision of certain assistance. Please contact:  
Public Information Dept., Pasco County Government Center 7530 Little Rd. New Port Richey, FL 34654 Phone: 727.847.8110 (voice) in New Port

Richey 352.521.4274, ext 8110 (voice) in Dade City Or 711 for the hearing impaired  
Contact should be initiated at least seven days before the scheduled court appearance, or immediately upon receiving this notification if the time before the scheduled appearance is less than seven days.  
The court does not provide transportation and cannot accommodate such requests. Persons with disabilities needing transportation to court should contact their local public transportation providers for information regarding transportation services.  
Dated in Hillsborough County, Florida, this 25th day of March, 2014  
/s/ Erik Del'Etoile  
Erik Del'Etoile, Esq.  
FL Bar # 71675  
Albertelli Law  
Attorney for Plaintiff  
P.O. Box 23028  
Tampa, FL 33623  
(813) 221-4743  
(813) 221-9171 facsimile  
eService:  
servealaw@albertellilaw.com  
BM - 002003F01  
Mar. 28; Apr. 4, 2014 14-01913P

## SECOND INSERTION

## NOTICE OF SALE PURSUANT TO CHAPTER 45 IN THE CIRCUIT COURT OF THE SIXTH JUDICIAL CIRCUIT IN AND FOR PASCO COUNTY, FLORIDA CIVIL ACTION

**CASE NO.: 51-2012-CA-006127-XXXX-WS NATIONSTAR MORTGAGE LLC, Plaintiff, vs. BAYLESS, CHRISTINE A. et al, Defendant(s).**  
NOTICE IS HEREBY GIVEN Pursuant to a Final Judgment of Foreclosure dated on or about February 26, 2014, and entered in Case No. 51-2012-CA-006127-XXXX-WS of the Circuit Court of the Sixth Judicial Circuit in and for Pasco County, Florida in which Nationstar Mortgage LLC, is the Plaintiff and Christine A. Bayless also known as Christine Hanlon, Jason Meyers, Mortgage Electronic Registration Systems, Inc., as nominee for SunTrust Mortgage, Inc., Sea Pines Civic Association, Inc., The Unknown Spouse of Christine A. Bayless also known as Christine Bayless, also known as Christine A. Hanlon, are defendants, the Pasco County Clerk of the Circuit Court will sell to the highest

and best bidder for cash in/on held online www.pasco.realforeclose.com: in Pasco County, Florida, Pasco County, Florida at 11:00AM on the 17th day of April, 2014, the following described property as set forth in said Final Judgment of Foreclosure:  
LOT 77, SEA PINES UNIT TWO, FIRST ADDITION, ACCORDING TO THE MAP OR PLAT THEREOF RECORDED IN PLAT BOOK 9, PAGE 92, PUBLIC RECORDS OF PASCO COUNTY, FLORIDA.  
7940 GULF WAY, HUDSON, FL 34667-4016  
Any person claiming an interest in the surplus from the sale, if any, other than the property owner as of the date of the Lis Pendens must file a claim within 60 days after the sale.  
If you are a person with a disability who needs an accommodation in order to participate in this proceeding, you are entitled, at no cost to you, to the provision of certain assistance. Please contact:  
Public Information Dept., Pasco County Government Center 7530 Little Rd. New Port Richey, FL 34654 Phone: 727.847.8110 (voice) in New Port

Richey 352.521.4274, ext 8110 (voice) in Dade City Or 711 for the hearing impaired  
Contact should be initiated at least seven days before the scheduled court appearance, or immediately upon receiving this notification if the time before the scheduled appearance is less than seven days.  
The court does not provide transportation and cannot accommodate such requests. Persons with disabilities needing transportation to court should contact their local public transportation providers for information regarding transportation services.  
Dated in Hillsborough County, Florida, this 25th day of March, 2014  
/s/ Erik Del'Etoile  
Erik Del'Etoile, Esq.  
FL Bar # 71675  
Albertelli Law  
Attorney for Plaintiff  
P.O. Box 23028  
Tampa, FL 33623  
(813) 221-4743  
(813) 221-9171 facsimile  
eService:  
servealaw@albertellilaw.com  
BM - 003931F01  
Mar. 28; Apr. 4, 2014 14-01914P

## SECOND INSERTION

## NOTICE OF SALE IN THE CIRCUIT CIVIL COURT OF THE SIXTH JUDICIAL CIRCUIT OF FLORIDA, IN AND FOR PASCO COUNTY CIVIL DIVISION

**Case No. 51-2011-CA-005239WS Division J3 WELLS FARGO BANK, N.A. Plaintiff, vs. PATRIARCHAL HOLDINGS, LLC, LINDA HANNAN, AND UNKNOWN TENANTS/OWNERS, Defendants.**  
Notice is hereby given, pursuant to Final Judgment of Foreclosure for Plaintiff entered in this cause on March 7, 2014, in the Circuit Court of Pasco County, Florida, Paula O'Neil, Clerk of the Circuit Court, will sell the property situated in Pasco County, Florida described as:  
LOT 11, TAHITIAN HOMES, UNIT ONE, ACCORDING TO THE PLAT THEREOF, AS RECORDED IN PLAT BOOK 8, PAGE(S) 141, OF THE PUBLIC RECORDS OF PASCO COUNTY, FLORIDA.  
and commonly known as: 4253 DARLINGTON RD, HOLIDAY, FL 34691; including the building, appurtenances, and fixtures located therein, at public sale, to the highest and best bidder, for cash, www.pasco.realforeclose.com, on April 22, 2014 at 11:00 AM.  
Any persons claiming an interest in the surplus from the sale, if any, other

than the property owner as of the date of the lis pendens must file a claim within 60 days after the sale.  
If you are a person with a disability who needs any accommodation in order to participate in this proceeding, you are entitled, at no cost to you, to the provision of certain assistance. Please contact the Public Information Dept., Pasco County Government Center, 7530 Little Rd., New Port Richey, FL 34654; (727) 847-8110 (V) in New Port Richey; (352) 521-4274, ext 8110 (V) in Dade City, at least 7 days before your scheduled court appearance, or immediately upon receiving this notification if the time before the scheduled appearance is less than 7 days; if you are hearing impaired call 711. The court does not provide transportation and cannot accommodate for this service. Persons with disabilities needing transportation to court should contact their local public transportation providers for information regarding transportation services.  
By: Edward B. Pritchard  
Attorney for Plaintiff  
Invoice to:  
Edward B. Pritchard  
(813) 229-0900 x1309  
Kass Shuler, P.A.  
P.O. Box 800  
Tampa, FL 33601-0800  
ForeclosureService@kasslaw.com  
317300/1107630/amml  
Mar. 28; Apr. 4, 2014 14-01837P

## SECOND INSERTION

## NOTICE OF SALE IN THE CIRCUIT CIVIL COURT OF THE SIXTH JUDICIAL CIRCUIT OF FLORIDA, IN AND FOR PASCO COUNTY CIVIL DIVISION

**Case No. 51-2013-CA-001180WS Division J2 WELLS FARGO BANK, N.A. Plaintiff, vs. SAFWAT HABIB, TAHANY SALEH AND UNKNOWN TENANTS/OWNERS, Defendants.**  
Notice is hereby given, pursuant to Final Judgment of Foreclosure for Plaintiff entered in this cause on February 26, 2014, in the Circuit Court of Pasco County, Florida, Paula O'Neil, Clerk of the Circuit Court, will sell the property situated in Pasco County, Florida described as:  
LOT 315, HOLIDAY GARDENS ESTATES, UNIT TWO, ACCORDING TO THE PLAT THEREOF, RECORDED IN PLAT BOOK 11, PAGES 22 AND 23, PUBLIC RECORDS OF PASCO COUNTY, FLORIDA.  
and commonly known as: 5850 8th AVENUE, NEW PORT RICHEY, FL 34652; including the building, appurtenances, and fixtures located therein, at public sale, to the highest and best bidder, for cash, www.pasco.realforeclose.com, on April 22, 2014 at 11:00 AM.  
Any persons claiming an interest in

the surplus from the sale, if any, other than the property owner as of the date of the lis pendens must file a claim within 60 days after the sale.  
If you are a person with a disability who needs any accommodation in order to participate in this proceeding, you are entitled, at no cost to you, to the provision of certain assistance. Please contact the Public Information Dept., Pasco County Government Center, 7530 Little Rd., New Port Richey, FL 34654; (727) 847-8110 (V) in New Port Richey; (352) 521-4274, ext 8110 (V) in Dade City, at least 7 days before your scheduled court appearance, or immediately upon receiving this notification if the time before the scheduled appearance is less than 7 days; if you are hearing impaired call 711. The court does not provide transportation and cannot accommodate for this service. Persons with disabilities needing transportation to court should contact their local public transportation providers for information regarding transportation services.  
By: Edward B. Pritchard  
Attorney for Plaintiff  
Invoice to:  
Edward B. Pritchard  
(813) 229-0900 x1309  
Kass Shuler, P.A.  
P.O. Box 800  
Tampa, FL 33601-0800  
ForeclosureService@kasslaw.com  
327611/1129038/amml  
Mar. 28; Apr. 4, 2014 14-01846P

## SECOND INSERTION

## NOTICE OF SALE IN THE COUNTY COURT IN AND FOR PASCO COUNTY, FLORIDA CIVIL ACTION

**CASE NO.: 2013-CC-003013-CCAX-WS FOX WOOD AT TRINITY COMMUNITY ASSOCIATION, INC. Plaintiff vs. RICHARD B. OWENS, et al, Defendant(s).**  
Notice is hereby given that, pursuant to a Final Judgment of Foreclosure or Order dated March 4, 2014, entered in Civil Case No. 2013-CC-003013-CCAX-WS, in the COUNTY COURT in and for PASCO COUNTY, Florida, wherein FOX WOOD AT TRINITY COMMUNITY ASSOCIATION, INC. is the Plaintiff, and RICHARD B. OWENS, et al., are the Defendants, I will sell the property situated in PASCO County, Florida, described as:  
Lot 532, FOX WOOD PHASE FOUR, according to the map or plat thereof, as recorded in Plat Book 38, Pages 50 through 56, of the Public Records of Pasco County, Florida.  
at public sale, to the highest and best bidder, for cash, at www.pasco.realforeclose.com, at 11:00 a.m. on the 9th day of April, 2014. Any person claiming an interest in the surplus from the sale, if any, other than the property owner as of the date of the lis pendens must file a claim within 60 days after the sale.

If you are a person with a disability who needs any accommodation in order to participate in this proceeding, you are entitled, at no cost to you, to the provision of certain assistance. Please contact the Public Information Dept., Pasco County Government Center, 7530 Little Rd., New Port Richey, FL 34654; (727) 847-8110 (V) in New Port Richey; (352) 521-4274, ext 8110 (V) in Dade City, at least 7 days before your scheduled court appearance, or immediately upon receiving this notification if the time before the scheduled appearance is less than 7 days; if you are hearing impaired call 711. The court does not provide transportation and cannot accommodate for this service. Persons with disabilities needing transportation to court should contact their local public transportation providers for information regarding transportation services.  
Dated March 21, 2014.  
/s/ Anne M. Malley  
Anne M. Malley, Esquire  
(SPN 1742783, FBN 075711)  
Anne M. Malley, P.A.  
210 S. Pinellas Avenue, Suite 200  
Tarpon Springs, FL 34689  
Phone: (727) 934-9400  
Fax: (727) 934-9455  
Primary E-Mail Address: pleadings@malley.com  
Secondary E-Mail Address: mliverman@malley.com  
Mar. 28; Apr. 4, 2014 14-01847P

## SECOND INSERTION

## NOTICE OF FORECLOSURE SALE IN THE CIRCUIT COURT OF THE SIXTH JUDICIAL CIRCUIT IN AND FOR PASCO COUNTY, FLORIDA CIVIL DIVISION

**Case No.: 51-2012-CA-008028ES HSBC BANK USA, N.A., AS INDENTURE TRUSTEE FOR THE REGISTERED NOTEHOLDERS OF RENAISSANCE HOME EQUITY LOAN TRUST 2006-2 Plaintiff, vs. KELLY HARRINGTON AUNGST F/K/A KELLY HARRINGTON A/K/A KELLY AUNGST; et al., Defendants.**  
NOTICE IS HEREBY GIVEN pursuant to a Final Judgment dated February 25, 2014, entered in Civil Case No.: 51-2012-CA-008028ES, of the Circuit Court of the SIXTH Judicial Circuit in and for PASCO COUNTY, Florida, wherein HSBC BANK USA, N.A., AS INDENTURE TRUSTEE FOR THE REGISTERED NOTEHOLDERS OF RENAISSANCE HOME EQUITY LOAN TRUST 2006-2, is Plaintiff, and KELLY HARRINGTON AUNGST F/K/A KELLY HARRINGTON A/K/A KELLY AUNGST; GULF STATE CREDIT, LLC; CAPITAL ONE BANK (USA), NATIONAL ASSOCIATION; STATE OF FLORIDA, DEPARTMENT OF REVENUE; CLERK OF THE CIRCUIT COURT FOR PASCO COUNTY, FLORIDA; UNKNOWN PERSON(S) IN POSSESSION OF THE SUBJECT PROPERTY; ALL OTHER UNKNOWN PARTIES CLAIMING INTERESTS BY, THROUGH, UNDER, AND AGAINST A NAMED DEFENDANT(S) WHO ARE NOT KNOWN TO BE DEAD OR ALIVE, WHETHER SAME UNKNOWN PARTIES MAY CLAIM AN INTEREST AS SPOUSES, HEIRS, DEVISEES, GRANTEEES, OR OTHER CLAIMANTS are Defendants.  
PAULA S. O'NEIL, Clerk of the Court, will sell to the highest bidder for cash at 11:00 a.m. online at www.pasco.realforeclose.com on the 14 day of April, 2014 the following described

real property as set forth in said Final Summary Judgment, to wit:  
THE SOUTH 75 FEET OF THE NORTH 145 FEET OF THE SOUTH 1/2 OF THE WEST 1/2 OF THE WEST 1/4 OF THE SOUTH-EAST 1/4 OF THE SOUTHWEST 1/4 OF THE SOUTHEAST 1/4 OF SECTION 27, TOWNSHIP 24 SOUTH, RANGE 21 EAST, OF THE PUBLIC RECORDS OF PASCO COUNTY, FLORIDA.  
This property is located at the Street address of: 14022 12th Street, Dade City, FL 33525.  
If you are a person claiming a right to funds remaining after the sale, you must file a claim with the clerk no later than 60 days after the sale. If you fail to file a claim you will not be entitled to any remaining funds. After 60 days, only the owner of record as of the date of the lis pendens may claim the surplus.  
If you are a person with a disability who needs an accommodation in order to participate in this proceeding, you are entitled, at no cost to you, to the provision of certain assistance. Please contact: Public Information Dept., Pasco County Government Center, 7530 Little Rd., New Port Richey, FL 34654. Phone: 727.847.8110 (voice) in New Port Richey 352.521.4274, ext 8110 (voice) in Dade City or 711 for the hearing impaired. Contact should be initiated at least seven days before the scheduled court appearance, or immediately upon receiving this notification if the time before the scheduled appearance is less than seven days  
Dated this 21 day of March, 2014.  
/s/ Joshua Sabet  
By: Joshua Sabet, Esquire  
Fla. Bar No.: 85356  
Primary Email:  
JSabet@ErwLaw.com  
Secondary Email:  
DocService@ErwLaw.com  
Attorney for Plaintiff:  
Elizabeth R. Wellborn, P.A.  
350 Jim Moran Blvd. Suite 100  
Deerfield Beach, FL 33442  
Telephone: (954) 354-3544  
Facsimile: (954) 354-3545  
File # 7525-12394  
Mar. 28; Apr. 4, 2014 14-01886P

## SECOND INSERTION

## NOTICE OF SALE IN THE CIRCUIT COURT OF THE SIXTH JUDICIAL CIRCUIT OF THE STATE OF FLORIDA, IN AND FOR PASCO COUNTY CIVIL DIVISION

**CASE NO. 51-2012-CA-006218-XXXX-WS U.S. BANK, NATIONAL ASSOCIATION, AS SUCCESSOR TRUSTEE TO BANK OF AMERICA, N.A., AS SUCCESSOR TO LASALLE BANK, N.A., AS TRUSTEE FOR THE MERRILL LYNCH FIRST FRANKLIN MORTGAGE LOAN TRUST, MORTGAGE LOAN ASSET-BACKED CERTIFICATES, SERIES 2007-H1, Plaintiff, vs. KELLY BROWN; UNKNOWN SPOUSE OF KELLY BROWN; AIMEE DOW; UNKNOWN SPOUSE OF AIMEE DOW; JIM BECK; IF LIVING, INCLUDING ANY UNKNOWN SPOUSE OF SAID DEFENDANT(S), IF REMARRIED, AND IF DECEASED, THE RESPECTIVE UNKNOWN HEIRS, DEVISEES, GRANTEEES, ASSIGNEES, CREDITORS, LIENORS, AND TRUSTEES, AND ALL OTHER PERSONS CLAIMING BY, THROUGH, UNDER OR AGAINST THE NAMED DEFENDANT(S); U.S. BANK, NATIONAL ASSOCIATION, AS SUCCESSOR TRUSTEE TO BANK OF AMERICA, N.A., AS SUCCESSOR TO LASALLE BANK, N.A., AS TRUSTEE FOR THE MERRILL LYNCH FIRST FRANKLIN MORTGAGE LOAN TRUST, MORTGAGE LOAN ASSET-BACKED CERTIFICATES, SERIES 2007-A; CHASE BANK (USA), N.A.; CAPITAL ONE BANK (USA), N.A.; WHETHER DISSOLVED OR PRESENTLY EXISTING, TOGETHER WITH ANY GRANTEEES, ASSIGNEES, CREDITORS, LIENORS, OR TRUSTEES OF SAID DEFENDANT(S) AND ALL OTHER PERSONS CLAIMING BY, THROUGH, UNDER, OR AGAINST DEFENDANT(S);**

**UNKNOWN TENANT #1; UNKNOWN TENANT #2; Defendant(s)**  
Notice is hereby given that, pursuant to a Final Summary Judgment of Foreclosure entered on 02/19/2014 in the above-styled cause, in the Circuit Court of Pasco County, Florida, the office of Paula S. O'Neil clerk of the circuit court will sell the property situate in Pasco County, Florida, described as:  
LOT 437, EMBASSY HILLS UNIT THREE, ACCORDING TO THE PLAT THEREOF AS RECORDED IN PLAT BOOK 11, PAGE 119 AND 120, OF THE PUBLIC RECORDS OF PASCO COUNTY, FLORIDA.  
at public sale, to the highest and best bidder, for cash, www.pasco.realforeclose.com at 11:00 o'clock, A.M., on April 16, 2014  
Any person claiming an interest in the surplus from the sale, if any, other than the property owner as of the date of the lis pendens, must file a claim within 60 days after the sale.  
If you are a person with a disability who needs any accommodation in order to participate in this proceeding, you are entitled, at no cost to you, to the provision of certain assistance. Please contact the Public Information Dept., Pasco County Government Center, 7530 Little Rd., New Port Richey, FL 34654; (727) 847-8110 (V) for proceedings in New Port Richey; (352) 521-4274, ext. 8110 (V) for proceedings in Dade City, at least 7 days before your scheduled court appearance, or immediately upon receiving this notification if the time before the scheduled appearance is less than 7 days; if you are hearing impaired call 711.  
Date: 03/25/2014  
ATTORNEY FOR PLAINTIFF  
By /S/ Josh D. Donnelly  
Josh D. Donnelly  
Florida Bar #64788  
THIS INSTRUMENT PREPARED BY:  
Law Offices of Daniel C. Consuegra  
9204 King Palm Drive  
Tampa, FL 33619-1328  
Phone: 813-915-8660  
Attorneys for Plaintiff  
127271-T  
Mar. 28; Apr. 4, 2014 14-01899P

## SECOND INSERTION

## NOTICE OF SALE IN THE CIRCUIT COURT OF THE SIXTH JUDICIAL CIRCUIT OF THE STATE OF FLORIDA, IN AND FOR PASCO COUNTY CIVIL DIVISION

**CASE NO. 51-2012-CA-002792-CAAX-WS CENLAR AS SERVICER FOR REAL ESTATE MORTGAGE NETWORK, INC., Plaintiff, vs. JAMIE A. DEAL; UNKNOWN SPOUSE OF JAMIE A. DEAL; IF LIVING, INCLUDING ANY UNKNOWN SPOUSE OF SAID DEFENDANT(S), IF REMARRIED, AND IF DECEASED, THE RESPECTIVE UNKNOWN HEIRS, DEVISEES, GRANTEEES, ASSIGNEES, CREDITORS, LIENORS, AND TRUSTEES, AND ALL OTHER PERSONS CLAIMING BY, THROUGH, UNDER OR AGAINST THE NAMED DEFENDANT(S); UNKNOWN TENANT #1; UNKNOWN TENANT #2; Defendant(s)**  
Notice is hereby given that, pursuant to a Final Summary Judgment of Foreclosure entered on 02/19/2014 in the above-styled cause, in the Circuit Court of Pasco County, Florida, the office of Paula S. O'Neil clerk of the circuit court will sell the property situate in Pasco County, Florida, described as:  
PARCEL 1A PORTION OF TRACT 2 OF AN UNRECORDED PLAT OF OAK LAKE RANCHETTES BEING THE NORTH 165.0 FEET OF THE SOUTH 1485.0 FEET OF THE EAST 1/4 OF THE WEST 1/2 OF THE NORTHEAST 1/4 OF SECTION 3, TOWNSHIP 24 SOUTH, RANGE 17 EAST, PASCO COUNTY, FLORIDA, THE EAST 15.0 FEET THEREOF BEING SUBJECT TO AN EASEMENT FOR INGRESS AND EGRESS OR UTILITIES, TOGETHER WITH EASEMENTS FOR INGRESS AND EGRESS AS DESCRIBED IN OFFICIAL

RECORDS BOOK 945, PAGE 1899, OF THE PUBLIC RECORDS OF PASCO COUNTY, FLORIDA.  
AND  
PARCEL 2 TRACT 2-C, REVISED OF UNRECORDED PLAT OF OAK LAKE RANCHETTES, THE NORTH 165.0 FEET OF THE SOUTH 1650.0 FEET OF THE EAST 1/2 OF THE EAST 1/2 OF THE WEST 1/2 OF THE NORTHEAST 1/4 OF SECTION 3, TOWNSHIP 24 SOUTH, RANGE 17 EAST, PASCO COUNTY, FLORIDA.  
at public sale, to the highest and best bidder, for cash, www.pasco.realforeclose.com at 11:00 o'clock, A.M., on April 17, 2014  
Any person claiming an interest in the surplus from the sale, if any, other than the property owner as of the date of the lis pendens, must file a claim within 60 days after the sale.  
If you are a person with a disability who needs any accommodation in order to participate in this proceeding, you are entitled, at no cost to you, to the provision of certain assistance. Please contact the Public Information Dept., Pasco County Government Center, 7530 Little Rd., New Port Richey, FL 34654; (727) 847-8110 (V) for proceedings in New Port Richey; (352) 521-4274, ext. 8110 (V) for proceedings in Dade City, at least 7 days before your scheduled court appearance, or immediately upon receiving this notification if the time before the scheduled appearance is less than 7 days; if you are hearing impaired call 711.  
Date: 03/25/2014  
ATTORNEY FOR PLAINTIFF  
By /S/ Josh D. Donnelly  
Josh D. Donnelly  
Florida Bar #64788  
THIS INSTRUMENT PREPARED BY:  
Law Offices of Daniel C. Consuegra  
9204 King Palm Drive  
Tampa, FL 33619-1328  
Phone: 813-915-8660  
Attorneys for Plaintiff  
122039-T  
Mar. 28; Apr. 4, 2014 14-01901P

## SECOND INSERTION

NOTICE OF FORECLOSURE SALE IN THE CIRCUIT COURT OF THE SIXTH JUDICIAL CIRCUIT IN AND FOR PASCO COUNTY, FLORIDA GENERAL JURISDICTION DIVISION

**CASE NO. 51-2009-CA-007967-ES HSBC BANK USA, NATIONAL ASSOCIATION, AS INDENTURE TRUSTEE OF THE FIELDSTONE MORTGAGE INVESTMENT TRUST, SERIES 2005-2, Plaintiff, vs. VANESSA AILEEN HAMWEY A/K/A VANESSA A HAMWAY AND BRIAN LEVESQUE HAMWEY A/K/A BRIAN L HAMWEY, et.al. Defendant(s).**

NOTICE IS HEREBY GIVEN pursuant to a Final Judgment of Foreclosure dated February 19, 2014, and entered in 51-2009-CA-007967-ES of the Circuit Court of the Sixth Judicial Circuit in and for Pasco County, Florida, wherein HSBC BANK USA, NATIONAL ASSOCIATION, AS INDENTURE TRUSTEE OF THE FIELDSTONE MORTGAGE INVESTMENT TRUST, SERIES 2005-2, is the Plaintiff and UNITED STATES OF AMERICA DEPARTMENT OF TREASURY; VAN-

ESSA AILEEN HAMWEY A/K/A VANESSA A HAMWAY; BRIAN LEVESQUE HAMWEY A/K/A BRIAN L HAMWEY; MORTGAGE ELECTRONIC REGISTRATION SYSTEMS, INC. AS NOMINEE FOR NATIONWIDE LENDING CORPORATION; MEADOW POINTE III HOMEOWNER'S ASSOCIATION, INC.; UNKNOWN TENANTS are the Defendant(s). Paula O'Neil as the Clerk of the Circuit Court will sell to the highest and best bidder for cash, www.pasco.realforeclose.com, at 11:00 AM on April 21, 2014, the following described property as set forth in said Final Judgment, to wit:

LOT 40, BLOCK 23, MEADOW POINT III, PARCEL "V-V", ACCORDING TO THE MAP OR PLAT THEREOF, AS RECORDED IN PLAT BOOK 45, PAGE 111, OF THE PUBLIC RECORDS OF PASCO COUNTY, FLORIDA.

Any person claiming an interest in the surplus from the sale, if any, other than the property owner as of the date of the lis pendens must file a claim within 60 days after the sale.

## IMPORTANT

If you are a person with a disability who needs any accommodation in or-

der to participate in this proceeding, you are entitled, at no cost to you, to the provision of certain assistance. Please contact the Public Information Dept., Pasco County Government Center, 7530 Little Rd., New Port Richey, FL 34654; (727) 847-8110 (V) in New Port Richey; (352) 521-4274, ext 8110 (V) in Dade City, at least 7 days before your scheduled court appearance, or immediately upon receiving this notification if the time before the scheduled appearance is less than 7 days; if you are hearing impaired call 711.

The court does not provide transportation and cannot accommodate for this service. Persons with disabilities needing transportation to court should contact their local public transportation providers for information regarding transportation services.

Dated this 24th day of March, 2014.

By: Liana R. Hall  
FL Bar No. 73813  
for Jamie Epstein  
Florida Bar: 68691

Robertson, Anschutz & Schneid, PL  
Attorneys for Plaintiff  
6409 Congress Avenue, Suite 100  
Boca Raton, Florida 33487  
13-15334

Mar. 28; Apr. 4, 2014 14-01883P

NOTICE OF FORECLOSURE SALE IN THE CIRCUIT COURT OF THE SIXTH JUDICIAL CIRCUIT IN AND FOR PASCO COUNTY, FLORIDA CIVIL DIVISION

**CASE NO.: 51-2012-CA-007302WS ONEWEST BANK, F.S.B. Plaintiff, v. LEO I. HAYDEN; ET AL. Defendants,**

NOTICE IS HEREBY GIVEN pursuant to a Final Judgment dated February 18, 2014, entered in Civil Case No.: 51-2012-CA-007302WS, of the Circuit Court of the SIXTH Judicial Circuit in and for Pasco County, Florida, wherein ONEWEST BANK, F.S.B. is Plaintiff, and LEO I. HAYDEN; DOLORES E. HAYDEN; UNITED STATES OF AMERICA ACTING ON BEHALF OF THE SECRETARY OF HOUSING AND URBAN DEVELOPMENT; TIMBER GREENS COMMUNITY ASSOCIATION, INC.; UNKNOWN TENANT #1; UNKNOWN TENANT #2; ALL OTHER UNKNOWN PARTIES CLAIMING INTERESTS BY, THROUGH, UNDER, AND AGAINST A NAMED DEFENDANT(S) WHO ARE NOT KNOWN TO BE DEAD OR ALIVE,

## SECOND INSERTION

WHETHER SAME UNKNOWN PARTIES MAY CLAIM AN INTEREST AS SPOUSES, HEIRS, DEVISEES, GRANTEES, OR OTHER CLAIMANTS, are Defendant(s).

PAULA S. O'NEIL, Clerk of the Court, will sell to the highest bidder for cash at 11:00 a.m. online at www.pasco.realforeclose.com on the 15th day of April, 2014 the following described real property as set forth in said Final Summary Judgment, to wit:

LOT 655, TIMBER GREENS PHASE 5, UNIT 16, ACCORDING TO THE PLAT THEREOF, AS RECORDED IN PLAT BOOK 33, PAGES 10 THROUGH 16, PUBLIC RECORDS OF PASCO COUNTY, FLORIDA.

If you are a person claiming a right to funds remaining after the sale, you must file a claim with the clerk no later than 60 days after the sale. If you fail to file a claim you will not be entitled to any remaining funds. After 60 days, only the owner of record as of the date of the lis pendens may claim the surplus.

IN ACCORDANCE WITH THE AMERICANS WITH DISABILITIES ACT, If you are a person with a disability who needs any accommoda-

tion in order to participate in this proceeding, you are entitled at no cost to you, to the provision of certain assistance. Please contact: Public Information Dept., Pasco County Government Center, 7530 Little Rd., New Port Richey; FL 34654; (727) 847-8110 (voice) for proceedings in New Port Richey; (352) 521-4274, ext 8110 (voice) for proceedings in Dade City at least 7 days before your scheduled court appearance, or immediately upon receiving this notification if the time before the scheduled appearance is less than 7 days; if you are hearing or voice impaired, call 711.

Dated this 20 day of March, 2014.

/s/ Joshua Sabet

By: Joshua Sabet, Esquire

Fla. Bar No.: 85356

Primary Email:

JSabet@ErwLaw.com

Secondary Email:

docservice@erwlaw.com

Attorney for Plaintiff:  
Elizabeth R. Wellborn, P.A.  
350 Jim Moran Blvd, Suite 100  
Deerfield Beach, FL 33442  
Telephone: (954) 354-3544  
Facsimile: (954) 354-3545  
FILE # 2012-04832  
Mar. 28; Apr. 4, 2014 14-01894P

## SECOND INSERTION

NOTICE OF FORECLOSURE SALE IN THE CIRCUIT COURT OF THE SIXTH JUDICIAL CIRCUIT, IN AND FOR PASCO COUNTY, FLORIDA CIVIL DIVISION

**CASE NO.: 51-2012-CA-008380-XXXX-WS JPMORGAN CHASE BANK, NATIONAL ASSOCIATION Plaintiff, vs. RICHARD J. MURPHY, et al Defendants.**

NOTICE IS HEREBY GIVEN pursuant to a Summary Final Judgment of foreclosure dated December 16, 2013, and entered in Case No. 51-2012-CA-008380-XXXX-WS of the Circuit Court of the SIXTH Judicial Circuit in and for PASCO COUNTY, Florida, wherein JPMORGAN CHASE BANK, NATIONAL ASSOCIATION, is Plaintiff, and RICHARD J. MURPHY, et al are Defendants, the clerk will sell to the highest and best bidder for cash, beginning at 11:00 AM at www.pasco.realforeclose.com, in accordance with Chapter 45, Florida Statutes, on the 21 day of April, 2014, the following described property as set forth in said Summary Final Judgment, to wit:

Lot 273, SEA RANCH ON THE GULF, FIFTH ADDITION, according to map or plat thereof as recorded in Plat Book 9, Page 67, of the Public Records of Pasco County, Florida.

Any person claiming an interest in the surplus funds from the sale, if any, other than the property owner as of the date of the lis pendens must file a claim within 60 days after the sale.

If you are a person with a disability who needs any accommodation in order to participate in this proceeding, you are entitled, at no cost to you, to the provision of certain assistance. Please contact the Public Information Dept., Pasco County Government Center, 7530 Little Rd., New Port Richey, FL 34654; (727) 847-8110 (V) in New Port Richey; (352) 521-4274, ext 8110 (V) in Dade City, at least seven (7) days before your scheduled court appearance, or immediately upon receiving this notification if the time before the scheduled appearance is less than seven (7) days; if you are hearing or voice impaired, call 711.

The court does not provide transportation and cannot accommodate for this service. Persons with disabilities needing transportation to court should contact their local public transportation providers for information regarding transportation services.

Dated: March 24, 2014

By: /s/ Heather J. Koch  
Phelan Hallinan, PLC  
Heather J. Koch, Esq.,  
Florida Bar No. 89107  
Emilio R. Lenzi, Esq.,  
Florida Bar No. 0668273

Phelan Hallinan, PLC  
Attorneys for Plaintiff  
2727 West Cypress Creek Road  
Ft. Lauderdale, FL 33309  
Tel: 954-462-7000

Fax: 954-462-7001  
Service by email:  
FL.Service@PhelanHallinan.com  
PH # 22827  
Mar. 28; Apr. 4, 2014 14-01855P

## SECOND INSERTION

NOTICE OF FORECLOSURE SALE IN THE CIRCUIT COURT OF THE SIXTH JUDICIAL CIRCUIT, IN AND FOR PASCO COUNTY, FLORIDA CIVIL DIVISION

**CASE NO.: 51-2012-CA-003961-XXXX-WS OCWEN LOAN SERVICING, LLC Plaintiff, vs. BEVERLY A. ROHLFS, et al Defendants.**

NOTICE IS HEREBY GIVEN pursuant to a Summary Final Judgment of foreclosure dated February 13, 2014, and entered in Case No. 51-2012-CA-003961-XXXX-WS of the Circuit Court of the SIXTH Judicial Circuit in and for PASCO COUNTY, Florida, wherein OCWEN LOAN SERVICING, LLC, is Plaintiff, and BEVERLY A. ROHLFS, et al are Defendants, the clerk will sell to the highest and best bidder for cash, beginning at 11:00 AM at www.pasco.realforeclose.com, in accordance with Chapter 45, Florida Statutes, on the 16 day of April, 2014, the following described property as set forth in said Summary Final Judgment, to wit:

Lot 137, The Oaks River Ridge Unit Two, according to the map or plat thereof recorded in Plat Book 24, Pages 26 through 29, inclusive, of Public Records of Pasco County, Florida.

Any person claiming an interest in the surplus funds from the sale, if any, other than the property owner as of the date of the lis pendens must file a claim within 60 days after the sale.

If you are a person with a disability who needs any accommodation in

order to participate in this proceeding, you are entitled, at no cost to you, to the provision of certain assistance. Please contact the Public Information Dept., Pasco County Government Center, 7530 Little Rd., New Port Richey, FL 34654; (727) 847-8110 (V) in New Port Richey; (352) 521-4274, ext 8110 (V) in Dade City, at least seven (7) days before your scheduled court appearance, or immediately upon receiving this notification if the time before the scheduled appearance is less than seven (7) days; if you are hearing or voice impaired, call 711.

The court does not provide transportation and cannot accommodate for this service. Persons with disabilities needing transportation to court should contact their local public transportation providers for information regarding transportation services.

Dated: March 24, 2014

By: /s/ Heather J. Koch  
Phelan Hallinan, PLC  
Heather J. Koch, Esq.,  
Florida Bar No. 89107  
Emilio R. Lenzi, Esq.,  
Florida Bar No. 0668273

Phelan Hallinan, PLC  
Attorneys for Plaintiff  
2727 West Cypress Creek Road  
Ft. Lauderdale, FL 33309  
Tel: 954-462-7000

Fax: 954-462-7001  
Service by email:  
FL.Service@PhelanHallinan.com  
PH # 24718  
Mar. 28; Apr. 4, 2014 14-01856P

## SECOND INSERTION

NOTICE OF SALE IN THE CIRCUIT COURT OF THE SIXTH JUDICIAL CIRCUIT OF THE STATE OF FLORIDA, IN AND FOR PASCO COUNTY CIVIL DIVISION

**CASE NO. 51-2011-CA-005538-CAAX-WS NATIONSTAR MORTGAGE LLC, Plaintiff, vs. HUNTER S. MELLRING; UNKNOWN SPOUSE OF HUNTER S. MELLRING; DIANE HENSLEY; UNKNOWN SPOUSE OF DIANE HENSLEY; IF LIVING, INCLUDING ANY UNKNOWN SPOUSE OF SAID DEFENDANT(S), IF REMARRIED, AND IF DECEASED, THE RESPECTIVE UNKNOWN HEIRS, DEVISEES, GRANTEES, ASSIGNEES, CREDITORS, LIENORS, AND TRUSTEES, AND ALL OTHER PERSONS CLAIMING BY, THROUGH, UNDER OR AGAINST THE NAMED DEFENDANT(S); UNKNOWN TENANT #1; UNKNOWN TENANT #2; Defendant(s)**

Notice is hereby given that, pursuant to a Final Summary Judgment of Foreclosure entered on 02/19/2014 in the above-styled cause, in the Circuit Court of Pasco County, Florida, the office of Paula S. O'Neil clerk of the circuit court will sell the property situate in Pasco County, Florida, described as:

LOT 2067, BEACON SQUARE, UNIT 18-A, ACCORDING TO THE PLAT THEREOF, AS RECORDED IN PLAT BOOK 10,

PAGE 61, OF THE PUBLIC RECORDS OF PASCO COUNTY, FLORIDA.

at public sale, to the highest and best bidder, for cash, www.pasco.realforeclose.com at 11:00 o'clock, A.M., on April 17, 2014

Any person claiming an interest in the surplus from the sale, if any, other than the property owner as of the date of the lis pendens, must file a claim within 60 days after the sale.

If you are a person with a disability who needs any accommodation in order to participate in this proceeding, you are entitled, at no cost to you, to the provision of certain assistance. Please contact the Public Information Dept., Pasco County Government Center, 7530 Little Rd., New Port Richey, FL 34654; (727) 847-8110 (V) for proceedings in New Port Richey; (352) 521-4274, ext. 8110 (V) for proceedings in Dade City, at least 7 days before your scheduled court appearance, or immediately upon receiving this notification if the time before the scheduled appearance is less than 7 days; if you are hearing impaired call 711.

Date: 03/25/2014

ATTORNEY FOR PLAINTIFF

By /S/ Josh D. Donnelly

Josh D. Donnelly

Florida Bar #64788

THIS INSTRUMENT PREPARED BY:

Law Offices of Daniel C. Consuegra  
9204 King Palm Drive  
Tampa, FL 33619-1328  
Phone: 813-915-8660  
Attorneys for Plaintiff  
103266  
Mar. 28; Apr. 4, 2014 14-01903P

## SECOND INSERTION

NOTICE OF SALE IN THE CIRCUIT COURT OF THE SIXTH JUDICIAL CIRCUIT OF THE STATE OF FLORIDA, IN AND FOR PASCO COUNTY CIVIL DIVISION

**CASE NO. 51-2013-CA-000933-CAAX-WS GTE FEDERAL CREDIT UNION, Plaintiff, vs. LISA M. KELLER; UNKNOWN SPOUSE OF LISA M. KELLER; IF LIVING, INCLUDING ANY UNKNOWN SPOUSE OF SAID DEFENDANT(S), IF REMARRIED, AND IF DECEASED, THE RESPECTIVE UNKNOWN HEIRS, DEVISEES, GRANTEES, ASSIGNEES, CREDITORS, LIENORS, AND TRUSTEES, AND ALL OTHER PERSONS CLAIMING BY, THROUGH, UNDER OR AGAINST THE NAMED DEFENDANT(S); LAKE KIMBERLY VILLAGE CONDOMINIUM ASSOCIATION, INC.; WHETHER DISSOLVED OR PRESENTLY EXISTING, TOGETHER WITH ANY GRANTEES, ASSIGNEES, CREDITORS, LIENORS, OR TRUSTEES OF SAID DEFENDANT(S) AND ALL OTHER PERSONS CLAIMING BY, THROUGH, UNDER, OR AGAINST DEFENDANT(S); UNKNOWN TENANT #1; UNKNOWN TENANT #2; Defendant(s)**

Notice is hereby given that, pursuant to a Final Summary Judgment of Foreclosure entered on 02/19/2014 in the above-styled cause, in the Circuit Court of Pasco County, Florida, the office of Paula S. O'Neil clerk of the circuit court will sell the property situate in Pasco County, Florida, described as:

CONDOMINIUM UNIT NO. 201, BUILDING 6, LAKE KIMBERLY VILLAGE CONDOMINIUM, ACCORDING TO THE DECLARATION THEREOF, AS RECORDED IN OFFICIAL RECORDS BOOK 1557, PAGE 1763, AS AMENDED AND CONDOMINIUM PLAT BOOK 3, PAGE 11 BOTH OF THE PUBLIC RECORDS OF PASCO COUNTY, FLORIDA.

at public sale, to the highest and best bidder, for cash, www.pasco.realforeclose.com at 11:00 o'clock, A.M., on April 15, 2014

Any person claiming an interest in the surplus from the sale, if any, other than the property owner as of the date of the lis pendens, must file a claim within 60 days after the sale.

If you are a person with a disability who needs any accommodation in order to participate in this proceeding, you are entitled, at no cost to you, to the provision of certain assistance. Please contact the Public Information Dept., Pasco County Government Center, 7530 Little Rd., New Port Richey, FL 34654; (727) 847-8110 (V) for proceedings in New Port Richey; (352) 521-4274, ext. 8110 (V) for proceedings in Dade City, at least 7 days before your scheduled court appearance, or immediately upon receiving this notification if the time before the scheduled appearance is less than 7 days; if you are hearing impaired call 711.

Date: 03/21/2014

ATTORNEY FOR PLAINTIFF

By /S/ Josh D. Donnelly

Josh D. Donnelly

Florida Bar #64788

THIS INSTRUMENT PREPARED BY:

Law Offices of Daniel C. Consuegra  
9204 King Palm Drive  
Tampa, FL 33619-1328  
Phone: 813-915-8660  
Attorneys for Plaintiff  
139501  
Mar. 28; Apr. 4, 2014 14-01848P

## SECOND INSERTION

NOTICE OF SALE IN THE CIRCUIT COURT OF THE SIXTH JUDICIAL CIRCUIT IN AND FOR PASCO COUNTY, FLORIDA CIVIL DIVISION

**CASE #: 51-2008-CA-009176ES (J1) DIVISION: J4 U.S. BANK NATIONAL ASSOCIATION AS TRUSTEE FOR THE CERTIFICATEHOLDERS OF STRUCTURED ASSET MORTGAGE INVESTMENTS II INC. BEAR STEARNS ALT-A TRUST, MORTGAGE PASS- THROUGH CERTIFICATES, SERIES 2006-3 Plaintiff, vs. Dominick John Lombardi a/k/a Dominick Lombardi; Mortgage Electronic Registration Systems, Inc., as Nominee for First Residential Mortgage Services Corporation; EquiLease Residential Services, LLC f/k/a EquiLease, LLC; The Belmont at Ryals Chase Condominium Association, Inc. Defendant(s).**

NOTICE IS HEREBY GIVEN pursuant to a Final Judgment, entered in Civil Case No. 51-2008-CA-009176ES (J1) of the Circuit Court of the 6th Judicial Circuit in and for Pasco County, Florida, wherein U.S. BANK NATIONAL ASSOCIATION AS TRUSTEE FOR THE CERTIFICATEHOLDERS OF STRUCTURED ASSET MORTGAGE INVESTMENTS II INC. BEAR STEARNS ALT-A TRUST, MORTGAGE PASS- THROUGH CERTIFICATES, SERIES 2006-3, Plaintiff and Dominick John Lombardi a/k/a Dominick Lombardi are defendant(s), I, Clerk of Court, Paula S. O'Neil, will sell to the highest and best bidder for cash in an online sale accessed through the Clerk's website at www.pasco.realforeclose.com, at 11:00 a.m. on April 28, 2014, the following described property as set forth in said Final Judgment,

to-wit:

UNIT 24-101, THE BELMONT AT RYALS CHASE, A CONDOMINIUM, AS PER THE DECLARATION OF CONDOMINIUM THEREOF, AS RECORDED IN OFFICIAL RECORDS BOOK 6561, PAGE 416, AS AMENDED FROM TIME TO TIME, OF THE PUBLIC RECORDS OF PASCO COUNTY, FLORIDA, TOGETHER WITH AN UNDIVIDED INTEREST TO THE COMMON ELEMENTS APPURTENANT THERETO, AS PER THE DECLARATION OF CONDOMINIUM.

ANY PERSON CLAIMING AN INTEREST IN THE SURPLUS FROM THE SALE, IF ANY, OTHER THAN THE PROPERTY OWNER AS OF THE DATE OF THE LIS PENDENS MUST FILE A CLAIM WITHIN 60 DAYS AFTER THE SALE.

If you are a person with a disability who needs any accommodation in order to participate in this proceeding, you are entitled, at no cost to you, to the provision of certain assistance. Please contact the ADA Coordinator; 14250 49th Street North, Clearwater, Florida 33762 (727) 453-7163 at least 7 days before your scheduled court appearance, or immediately upon receiving this notification of the time before the scheduled appearance is less than 7 days. If you are hearing or voice impaired, call 711.

Submitted By:

ATTORNEY FOR PLAINTIFF:

SHAPIRO, FISHMAN & GACHÉ, LLP  
2424 North Federal Highway,  
Suite 360  
Boca Raton, Florida 33431  
(561) 998-6700  
(561) 998-6707  
08-113747 FCO1 SPS  
Mar. 28; Apr. 4, 2014 14-01867P

## SECOND INSERTION

NOTICE OF SALE PURSUANT TO CHAPTER 45 IN THE CIRCUIT COURT OF THE SIXTH JUDICIAL CIRCUIT IN AND FOR PASCO COUNTY, FLORIDA CIVIL ACTION

**CASE NO.: 51-2013-CA-000679-CAAX-WS U.S. BANK NATIONAL ASSOCIATION, AS TRUSTEE, SUCCESSOR IN INTEREST TO WACHOVIA BANK, N.A., AS TRUSTEE, FOR MASTR ALTERNATIVE LOAN TRUST 2004-3 MORTGAGE PASS-THROUGH CERTIFICATES, SERIES 2004-3, Plaintiff, vs. LANGROCK, PAUL M. et al, Defendant(s).**

NOTICE IS HEREBY GIVEN Pursuant to a Final Judgment of Foreclosure dated January 30, 2014, and entered in Case No. 51-2013-CA-000679-CAAX-WS of the Circuit Court of the Sixth Judicial Circuit in and for Pasco County, Florida in which U.S. Bank National Association, as Trustee, Successor in interest to Wachovia Bank, N.A., as Trustee, for MASTR Alternative Loan Trust 2004-3 Mortgage Pass-Through Certificates, Series 2004-3, is the Plaintiff and Deborah R. Langrock, Paul M. Langrock, Tenant # 1 also known as John McCann, are defendants, the Pasco County Clerk of the Circuit Court will sell to the highest and best bidder for cash in/on held online www.pasco.realforeclose.com: in Pasco County, Florida, Pasco County, Florida at 11:00AM on the 30th day of April 2014, the following described property as set forth in said Final Judgment of Foreclosure:

LOT 2394, EMBASSY HILLS UNIT FIFTEEN, ACCORDING TO THE PLAT THEREOF, RECORDED IN PLAT BOOK 15, PAGE 133 AND 134, OF THE PUBLIC RECORDS OF PASCO COUNTY, FLORIDA.

9213 GLEN MOOR LN PORT RICHEY FL 34668-4911

Any person claiming an interest in the surplus from the sale, if any, other than the property owner as of the date of the Lis Pendens must file a claim within 60 days after the sale.

If you are a person with a disability who needs an accommodation in order to participate in this proceeding, you are entitled, at no cost to you, to the provision of certain assistance. Please contact:

Public Information Dept., Pasco County Government Center 7530 Little Rd. New Port Richey, FL 34654 Phone: 727.847.8110 (voice) in New Port Richey 352.521.4274, ext 8110 (voice) in Dade City Or 711 for the hearing impaired

Contact should be initiated at least seven days before the scheduled court appearance, or immediately upon receiving this notification if the time before the scheduled appearance is less than seven days.

The court does not provide transportation and cannot accommodate such requests. Persons with disabilities needing transportation to court should contact their local public transportation providers for information regarding transportation services.

Dated in Hillsborough County, Florida, this 24th day of March, 2014

/s/ Erik Del'Etoile  
Erik Del'Etoile, Esq.  
FL Bar # 71675

Albertelli Law  
Attorney for Plaintiff  
P.O. Box 23028  
Tampa, FL 33623  
(813) 221-4743  
(813) 221-9171 facsimile  
eService:  
servealaw@albertellilaw.com  
JR- 013554F01  
Mar. 28; Apr. 4, 2014 14-01874P

## SECOND INSERTION

NOTICE OF FORECLOSURE SALE IN THE CIRCUIT COURT OF THE SIXTH JUDICIAL CIRCUIT, IN AND FOR PASCO COUNTY, FLORIDA.

**CASE NO. 51-2008-CA-003263-XXXX-ES J1**  
**DEUTSCHE BANK NATIONAL TRUST COMPANY, AS TRUSTEE FOR AMERIQUEST MORTGAGE SECURITIES INC., ASSET-BACKED PASS-THROUGH CERTIFICATES, SERIES 2006-R1, PLAINTIFF, VS. JAMES C. TERRY, II, ET AL. DEFENDANT(S).**  
NOTICE IS HEREBY GIVEN pursuant to the Final Judgment of Foreclosure dated January 7, 2014 in the above action, the Pasco County Clerk of Court will sell to the highest bidder for cash at Pasco, Florida, on May 7, 2014, at 11:00 AM, at [www.pasco.realforeclose.com](http://www.pasco.realforeclose.com) for the following described property:  
PARCEL #5:  
PART OF TRACT #7 OF QUAIL HOLLOW ESTATES DESCRIBED AS FOLLOWS:  
FROM THE NORTHEAST CORNER OF SECTION 1, TOWNSHIP 26 SOUTH, RANGE 19 EAST, PASCO COUNTY, FLORIDA, RUN

S. 00 DEGREES 54'09" W. 2648.59 FEET, ALONG THE EAST BOUNDARY OF SAID SECTION 1, THENCE N. 88 DEGREES 59'31" W. 373.95 FEET; THENCE N. 01 DEGREES 00'29" E. 326.32 FEET; THENCE N. 88 DEGREES 59'31" W. 622.85 FEET FOR A POINT OF BEGINNING; THENCE CONTINUING N. 88 DEGREES 59'31" W. 151.65 FEET; THENCE N. 01 DEGREES 00'29" E. 293.33 FEET; THENCE N. 89 DEGREES 15'32" E. 151.72 FEET; THENCE S. 01 DEGREES 00'29" W. 297.97 FEET TO THE POINT OF BEGINNING.

Any person claiming an interest in the surplus from the sale, if any, other than the property owner as of the date of the lis pendens must file a claim within sixty (60) days after the sale. The Court, in its discretion, may enlarge the time of the sale. Notice of the changed time of sale shall be published as provided herein.

If you are a person with a disability who needs any accommodation in order to participate in this proceeding, you are entitled, at no cost to you, to the

provision of certain assistance. Please contact the Public Information Department at 727-847-8110 in New Port Richey or 352-521-4274, extension 8110 in Dade City or at Pasco County Government Center, 7530 Little Road, New Port Richey, FL 34654 at least 7 days before your scheduled court appearance, or immediately upon receiving this notification if the time before the scheduled appearance is less than 7 days; if you are hearing or voice impaired, call 711.

The court does not provide transportation and cannot accommodate such requests. Persons with disabilities needing transportation to court should contact their local public transportation providers for information regarding transportation services.  
By: Marie Fox, Esq.  
FBN 43909

Gladstone Law Group, P.A.  
Attorney for Plaintiff  
1499 W. Palmetto Park Road,  
Suite 300  
Boca Raton, FL 33486  
Telephone #: 561-338-4101  
Fax #: 561-338-4077  
Email: [eservice@glaw.net](mailto:eservice@glaw.net)  
Our Case #: 09-000482-FST  
Mar. 28; Apr. 4, 2014 14-01919P

NOTICE OF FORECLOSURE SALE PURSUANT TO CHAPTER 45 IN THE CIRCUIT COURT OF THE SIXTH JUDICIAL CIRCUIT IN AND FOR PASCO COUNTY, FLORIDA

**CASE NO. 51-2012-CA-005401-ES/J4**  
**OCWEN LOAN SERVICING, LLC Plaintiff(s), vs. CHRISTOPHER BERNHARD; et al., Defendant(s).**  
NOTICE IS HEREBY GIVEN THAT Sale will be made pursuant to an Order or Final Summary Judgment. Final Judgment was awarded on February 20, 2014 in Civil Case No. 51-2012-CA-005401-ES/J4, of the Circuit Court of the SIXTH Judicial Circuit in and for PASCO County, Florida, wherein, OCWEN LOAN SERVICING, LLC is the Plaintiff, and, CHRISTOPHER BERNHARD; RHONDA BERNHARD; THE PRESERVE AT LAKE THOMAS HOMEOWNERS ASSOCIATION, INC.; HOUSEHOLD FINANCE CORPORATION III; SECRETARY OF HOUSING AND URBAN DEVELOPMENT; PAULA R. LEWIS; PASCO COUNTY CLERK OF THE COURT; AND UNKNOWN TENANT(S) IN POSSESSION are Defendants.  
The clerk of the court, Paula S.

## SECOND INSERTION

O'Neil, Ph.D., will sell to the highest bidder for cash online at [www.pasco.realforeclose.com](http://www.pasco.realforeclose.com) at 11:00 AM on April 10, 2014, the following described real property as set forth in said Final Summary Judgment, to wit:

LOT 32, THE PRESERVE AT LAKE THOMAS, ACCORDING TO THE MAP OR PLAT THEREOF AS RECORDED IN PLAT BOOK 32, PAGE 122, PUBLIC RECORDS OF PASCO COUNTY, FLORIDA.  
PROPERTY ADDRESS: 21219 PRESERVATION DRIVE, LAND O LAKES, FL 34638  
ANY PERSON CLAIMING AN INTEREST IN THE SURPLUS FROM THE SALE, IF ANY, OTHER THAN THE PROPERTY OWNER AS OF THE DATE OF THE LIS PENDENS MUST FILE A CLAIM WITHIN 60 DAYS AFTER THE SALE.  
IMPORTANT

If you are a person with a disability who needs an accommodation in order to participate in this proceeding, you are entitled, at no cost to you, to the provision of certain assistance. Please contact: Public Information Dept., Pasco County Government Center, 7530 Little Rd., New Port Richey, FL

34654; Phone: 727.847.8110 (voice) in New Port Richey, 352.521.4274; ext 8110 (voice) in Dade City, Or 711 for the hearing impaired. Contact should be initiated at least seven days before the scheduled court appearance, or immediately upon receiving this notification if the time before the scheduled appearance is less than seven days. The court does not provide transportation and cannot accommodate such requests. Persons with disabilities needing transportation to court should contact their local public transportation providers for information regarding transportation services.  
Dated this 25 day of March, 2014.

BY: Nalini Singh  
FBN: 43700  
Primary E-Mail: [ServiceMail@aclawllp.com](mailto:ServiceMail@aclawllp.com)  
Secondary E-Mail: [NSingh@aclawllp.com](mailto:NSingh@aclawllp.com)  
Aldridge | Connors, LLP  
Attorney for Plaintiff(s)  
1615 South Congress Avenue  
Suite 200  
Delray Beach, FL 33445  
Phone: 561.392.6391  
Fax: 561.392.6965  
1248-521  
Mar. 28; Apr. 4, 2014 14-01908P

## SECOND INSERTION

NOTICE OF FORECLOSURE SALE IN THE CIRCUIT COURT OF THE SIXTH JUDICIAL CIRCUIT, IN AND FOR PASCO COUNTY, FLORIDA

**CIVIL DIVISION**  
**CASE NO.: 51-2012-CA-006474-XXXX-WS**  
**JPMORGAN CHASE BANK, NATIONAL ASSOCIATION, Plaintiff, vs. KARL A. GORE, et al Defendants.**  
NOTICE IS HEREBY GIVEN pursuant to a Summary Final Judgment of foreclosure dated December 16, 2013, and entered in Case No. 51-2012-CA-006474-XXXX-WS of the Circuit Court of the SIXTH Judicial Circuit in and for PASCO COUNTY, Florida, wherein JPMORGAN CHASE BANK, NATIONAL ASSOCIATION, is Plaintiff, and KARL A. GORE, et al are Defendants, the clerk will sell to the highest and best bidder for cash, beginning at 11:00 AM at [www.pasco.realforeclose.com](http://www.pasco.realforeclose.com), in accordance with Chapter 45, Florida Statutes, on the 21 day of April, 2014, the following described property as set forth in said Summary Final Judgment, to wit:  
LOT 658, FOREST HILLS UNIT NO. 11, according to the map or plat thereof as recorded in Plat Book 9, Pages 15 and 16, Public Records of Pasco County, Florida.  
Any person claiming an interest in the surplus funds from the sale, if any, other than the property owner as of the date of the lis pendens must file a claim within 60 days after the sale.

If you are a person with a disability who needs any accommodation in order to participate in this proceeding, you are entitled, at no cost to you, to the provision of certain assistance. Please contact the Public Information Dept., Pasco County Government Center, 7530 Little Rd., New Port Richey, FL 34654; (727) 847-8110 (V) in New Port Richey; (352) 521-4274, ext 8110 (V) in Dade City, at least seven (7) days before your scheduled court appearance, or immediately upon receiving this notification if the time before the scheduled appearance is less than seven (7) days; if you are hearing or voice impaired, call 711.

The court does not provide transportation and cannot accommodate for this service. Persons with disabilities needing transportation to court should contact their local public transportation providers for information regarding transportation services.  
Dated: March 24, 2014

By: /s/ Heather J. Koch  
Phelan Hallinan, PLC  
Heather J. Koch, Esq.,  
Florida Bar No. 89107  
Emilio R. Lenzi, Esq.,  
Florida Bar No. 0668273  
Phelan Hallinan, PLC  
Attorneys for Plaintiff  
2727 West Cypress Creek Road  
Ft. Lauderdale, FL 33309  
Tel: 954-462-7000  
Fax: 954-462-7001  
Service by email:  
[FL.Service@PhelanHallinan.com](mailto:FL.Service@PhelanHallinan.com)  
PH # 28460  
Mar. 28; Apr. 4, 2014 14-01857P

## SECOND INSERTION

NOTICE OF FORECLOSURE SALE IN THE CIRCUIT COURT OF THE SIXTH JUDICIAL CIRCUIT, IN AND FOR PASCO COUNTY, FLORIDA

**CIVIL DIVISION**  
**CASE NO.: 51-2012-CA-005143-XXXX-WS**  
**CITIMORTGAGE, INC. Plaintiff, vs. EDWARD G. RIZZOTTO, et al Defendants.**  
NOTICE IS HEREBY GIVEN pursuant to a Summary Final Judgment of foreclosure dated March 05, 2014, and entered in Case No. 51-2012-CA-005143-XXXX-WS of the Circuit Court of the SIXTH Judicial Circuit in and for PASCO COUNTY, Florida, wherein CITIMORTGAGE, INC., is Plaintiff, and EDWARD G. RIZZOTTO, et al are Defendants, the clerk will sell to the highest and best bidder for cash, beginning at 11:00 AM at [www.pasco.realforeclose.com](http://www.pasco.realforeclose.com), in accordance with Chapter 45, Florida Statutes, on the 21 day of April, 2014, the following described property as set forth in said Summary Final Judgment, to wit:  
Lot 254, COLONIAL MANOR, UNIT FIVE, according to the plat thereof as recorded in Plat Book 8, Page 100, of the Public Records of Pasco County, Florida.  
Any person claiming an interest in the surplus funds from the sale, if any, other than the property owner as of the date of the lis pendens must file a claim within 60 days after the sale.  
If you are a person with a disability

who needs any accommodation in order to participate in this proceeding, you are entitled, at no cost to you, to the provision of certain assistance. Please contact the Public Information Dept., Pasco County Government Center, 7530 Little Rd., New Port Richey, FL 34654; (727) 847-8110 (V) in New Port Richey; (352) 521-4274, ext 8110 (V) in Dade City, at least seven (7) days before your scheduled court appearance, or immediately upon receiving this notification if the time before the scheduled appearance is less than seven (7) days; if you are hearing or voice impaired, call 711.

The court does not provide transportation and cannot accommodate for this service. Persons with disabilities needing transportation to court should contact their local public transportation providers for information regarding transportation services.  
Dated: March 24, 2014

By: /s/ Heather J. Koch  
Phelan Hallinan, PLC  
Heather J. Koch, Esq.,  
Florida Bar No. 89107  
Emilio R. Lenzi, Esq.,  
Florida Bar No. 0668273  
Phelan Hallinan, PLC  
Attorneys for Plaintiff  
2727 West Cypress Creek Road  
Ft. Lauderdale, FL 33309  
Tel: 954-462-7000  
Fax: 954-462-7001  
Service by email:  
[FL.Service@PhelanHallinan.com](mailto:FL.Service@PhelanHallinan.com)  
PH # 32210  
Mar. 28; Apr. 4, 2014 14-01858P

## SECOND INSERTION

RE-NOTICE OF FORECLOSURE SALE IN THE CIRCUIT COURT OF THE 6th JUDICIAL CIRCUIT IN AND FOR PASCO COUNTY, FLORIDA

**CASE NO.: 51-2012-CA-002626-XXXX-ES**  
**Space Coast Credit Union, as Servicer for Federal Home Loan Bank of Atlanta Plaintiff, vs. Timothy M. Loftus, JOHN and JANE DOE, Unknown Parties/tenants in possession, Defendant(s).**  
NOTICE OF SALE IS HEREBY GIVEN, pursuant to an order of Final Judgment of Foreclosure dated October 8, 2013 and entered in case 51-2012-CA-002626-XXXX-ES of the Circuit Court of the Sixth Judicial Circuit and for Pinellas County, Florida wherein Space Coast Credit Union, as Servicer for Federal Home Loan Bank of Atlanta is the Plaintiff and Timothy M. Loftus is the Defendant, the Clerk of Court shall sell to the highest bidder for case at: [www.pasco.realforeclose.com](http://www.pasco.realforeclose.com), at 11:00am on the 17th of APRIL, 2014, the following described property as set forth in said Order of Final Judgment to wit:  
Lot 34, Block 3, Englewood Phase One, according to the Plat recorded in Plat Book 32, Page 143 as recorded in the Public Records of Pasco County, Florida: said situate, lying and being in Pasco County, Florida.  
(legal description).  
Property Address: 5124 New Britany Lane, Zephyrhills, FL 33541.

Any person claiming an interest in the surplus from the sale, if any, other than the Property owner as of the date of the Lis Pendens must file a claim within sixty (60) days after the sale.

If you are a person with a disability who needs any accommodation in order to participate in this proceeding, you are entitled, at no cost to you, to the provision of certain assistance. Within two (2) working days of your receipt of this (describe notice/order) please contact the Public Information Dept., Pasco County Government Center, 7530 Little Rd., New Port Richey, FL 34654; (727) 847-8110 (V) in New Port Richey; (352) 521-4274, ext. 8110 (V) in Dade City; via 1-800-955-8771 if you are hearing impaired. The court does not provide transportation and cannot accommodate for this service. Persons with disabilities needing transportation to court should contact their local public transportation providers for information regarding transportation services.  
By: Isabel V. Collieran  
450472  
for Moises T. Grayson, Esq.,  
FBN: 369519

BLAXBERG, GRAYSON, KUKOFF & TWOMBLY, P.A.  
25 SE 2nd Avenue, Suite 730  
Miami, FL 33131  
Telephone: (305) 381-7979  
Facsimile: (305) 371-6816  
Primary e-mail:  
[SCCU-FHLB@blaxgray.com](mailto:SCCU-FHLB@blaxgray.com)  
Secondary e-mail:  
[isabel.collieran@blaxgray.com](mailto:isabel.collieran@blaxgray.com)  
Mar. 28; Apr. 4, 2014 14-01861P

## SECOND INSERTION

NOTICE OF FORECLOSURE SALE IN THE CIRCUIT COURT OF THE SIXTH JUDICIAL CIRCUIT IN AND FOR PASCO COUNTY, STATE OF FLORIDA

**CIVIL DIVISION**  
**Case No. 51-2008-CA-7473-WS**  
**Division J3**  
**PASCO PROPERTIES, INC., a Florida Corporation Plaintiff, v. DARLENE DEEGAN PANESON and CAPRICORN INVESTMENT CORPORATION, INC., a Florida Corporation, Defendants.**  
NOTICE IS HEREBY GIVEN pursuant to a Final Judgment of Foreclosure dated March 19, 2014, entered in Civil Case No. 51-2008-CA-7473-WS, of the Circuit Court of the Sixth Judicial Circuit in and for Pasco County, Florida, wherein PASCO PROPERTIES, INC. is the Plaintiff, and DARLENE DEEGAN PANESON and CAPRICORN INVESTMENT CORPORATION, INC., are Defendants, that I will sell to the highest and best bidder for cash, at [www.pasco.realforeclose.com](http://www.pasco.realforeclose.com), at 11:00 a.m. on May 5, 2014, the following described property as set forth in the Final Judgment of Foreclosure, to wit:  
Parcel 1-B, Commence at the Northwest corner of the Southeast 1/4 of the Southwest 1/4 of Section 27, Township 24 South, Range 16 East, Pasco County, Florida; thence run along the West boundary of said Southeast 1/4 of the Southwest 1/4, South 00° 48'15" E, 292.36 feet for a Point of Beginning; thence S 51° 07'23" E, 163.44 feet to the Westerly right-of-way line of U.S. Highway 19; thence along said right-of-way line S 38° 52'37" W, 105 feet; thence N 51° 07'23" W, 76.33 feet to the West boundary of said Southeast 1/4 of the Southwest 1/4, thence N 00° 48'15" W, 136.43 feet to the

Point of Beginning. Also the South 1.5 feet of Lot 13, all of Lots 14, 15, and 16, Block A, GULF BREEZE HEIGHTS, said portion of lot, lots, block and subdivision being numbered and designated in accordance with the plat of said subdivision as the same appears of record in Plat Book 2, Page 59, Public Records of Pasco County, Florida  
ANY PERSON CLAIMING AN INTEREST IN THE SURPLUS FROM THE SALE, IF ANY, OTHER THAN THE PROPERTY OWNER AS OF THE DATE OF THE LIS PENDENS, MUST FILE A CLAIM WITHIN 60 DAYS AFTER THE SALE.

If you are a person with a disability who needs any accommodation in order to participate in this proceeding, you are entitled, at no cost to you to the provisions of certain assistance. Within two (2) working days of your receipt of this (describe notice/order) please contact the Public Information Dept., Pasco County Government Center, 7530 Little Rd., New Port Richey, FL 34654; (727) 847-8110 (V) in New Port Richey; (352) 521-4274, ext. 8110 (V) in Dade City; via 1-00-955-8771 if you are hearing impaired. The court does not provide transportation and cannot accommodate for this service. Persons with disabilities needing transportation to court should contact their local public transportation providers for information regarding disabled transportation services.  
DATED this 24 day of March, 2014.

Frederick T. Reeves, Esq.  
Fla. Bar No. 499234  
Frederick T. Reeves, P.A.  
5709 Tidallwave Drive  
New Port Richey, FL 34652  
Telephone (727) 844-3006  
Facsimile (727) 844-3114  
[freeves@tbaylaw.com](mailto:freeves@tbaylaw.com)  
[meghancox@tbaylaw.com](mailto:meghancox@tbaylaw.com)  
Attorney for Pasco Properties, Inc.  
Mar. 28; Apr. 4, 2014 14-01862P

## SECOND INSERTION

NOTICE OF SALE PURSUANT TO CHAPTER 45 IN THE CIRCUIT COURT OF THE SIXTH JUDICIAL CIRCUIT IN AND FOR PASCO COUNTY, FLORIDA

**CIVIL ACTION**  
**CASE NO.: 51-2013-CA-000661-CAAX-WS**  
**U.S. BANK TRUST NATIONAL ASSOCIATION, NOT IN ITS INDIVIDUAL CAPACITY BUT SOLELY AS DELAWARE TRUSTEE AND U.S. BANK NATIONAL ASSOCIATION, NOT IN ITS INDIVIDUAL CAPACITY BUT SOLELY AS CO-TRUSTEE FOR GOVERNMENT LOAN SECURITIZATION TRUST 2011-FV1, Plaintiff, vs. PEIRCE, ROBERT C. et al, Defendant(s).**  
NOTICE IS HEREBY GIVEN Pursuant to a Final Judgment of Foreclosure dated February 26, 2014, and entered in Case No. 51-2013-CA-000661-CAAX-WS of the Circuit Court of the Sixth Judicial Circuit in and for Pasco County, Florida in which U.S. Bank Trust National Association, not in its individual capacity but solely as Delaware trustee and U.S. Bank National Association, not in its individual capacity but solely as Co-Trustee for Government Loan Securitization Trust 2011-FV1, is the Plaintiff and Robert C. Peirce, Susan Peirce, WCRSI, LLC, are defendants, the Pasco County Clerk of the Circuit Court will sell to the highest and best bidder for cash in/on held online [www.pasco.realforeclose.com](http://www.pasco.realforeclose.com): in Pasco County, Florida, Pasco County, Florida at 11:00AM on the 16th day of April, 2014, the following described property as set forth in said Final Judgment of Foreclosure:  
LOT 9, TRACT 1, HILLCREST ACRES, AS RECORDED IN O.R. 585, PAGE 476; SAID TRACT BEING ALSO DESCRIBED AS TRACT 1 THE NORTH 1010 FEET OF LOTS 9 AND 10 OF BLOCK B, GULF COAST ACRES

ADDITION, AS RECORDED IN PLAT BOOK 5. PAGE 145. OF THE PUBLIC RECORDS OF PASCO COUNTY, FLORIDA.  
15313 MORNAY DR, HUDSON, FL 34667-3815

Any person claiming an interest in the surplus from the sale, if any, other than the property owner as of the date of the Lis Pendens must file a claim within 60 days after the sale.

If you are a person with a disability who needs an accommodation in order to participate in this proceeding, you are entitled, at no cost to you, to the provision of certain assistance. Please contact:

Public Information Dept., Pasco County Government Center 7530 Little Rd. New Port Richey, FL 34654 Phone: 727.847.8110 (voice) in New Port Richey 352.521.4274, ext 8110 (voice) in Dade City Or 711 for the hearing impaired

Contact should be initiated at least seven days before the scheduled court appearance, or immediately upon receiving this notification if the time before the scheduled appearance is less than seven days.

The court does not provide transportation and cannot accommodate such requests. Persons with disabilities needing transportation to court should contact their local public transportation providers for information regarding transportation services.

Dated in Hillsborough County, Florida, this 24th day of March, 2014  
/s/ Erik Del'Etoile  
Erik Del'Etoile, Esq.  
FL Bar # 71675

Albertelli Law  
Attorney for Plaintiff  
P.O. Box 23028  
Tampa, FL 33623  
(813) 221-4743  
(813) 221-9171 facsimile  
eService:  
[servealaw@albertellilaw.com](mailto:servealaw@albertellilaw.com)  
BM - 014068F01  
Mar. 28; Apr. 4, 2014 14-01879P

## SECOND INSERTION

NOTICE OF FORECLOSURE SALE IN THE CIRCUIT COURT OF THE SIXTH JUDICIAL CIRCUIT IN AND FOR PASCO COUNTY, FLORIDA

**CIVIL DIVISION**  
**Case No.: 51-2012-CA-003077-CAAX-WS**  
**Division: J3**  
**ONEWEST BANK, F.S.B. Plaintiff, v. JAMES D. BYRD, AS TRUSTEE OF THE JAMES D. BYRD, TRUST DATED 7/1/2003, DECEASED; ET AL. Defendants,**  
NOTICE IS HEREBY GIVEN pursuant to a Final Judgment dated February 18, 2014, entered in Civil Case No. 51-2012-CA-003077-CAAX-WS, DIVISION: J3, of the Circuit Court of the SIXTH Judicial Circuit in and for Pasco County, Florida, wherein ONEWEST BANK, F.S.B. is Plaintiff, and JAMES D. BYRD, AS TRUSTEE OF THE JAMES D. BYRD, TRUST DATED 7/1/2003, DECEASED; THE UNKNOWN BENEFICIARIES OF THE JAMES D. BYRD TRUST DATED JULY 2, 2003; THE UNKNOWN SUCCESSOR TRUSTEE OF THE JAMES D. BYRD TRUST DATED JULY 1, 2003; MARK ALAN BYRD, POSSIBLE UNKNOWN TENANT #1; UNKNOWN TENANT #2; ALL OTHER UNKNOWN PARTIES CLAIMING INTERESTS BY, THROUGH, UNDER, AND AGAINST A NAMED DEFENDANT(S) WHO ARE NOT KNOWN TO BE DEAD OR ALIVE, WHETHER SAME UNKNOWN PARTIES MAY CLAIM AN INTEREST AS SPOUSES, HEIRS, DEVISEES, GRANTEES, OR OTHER CLAIMANTS, are Defendant(s).  
PAULA S. O'NEIL, Clerk of the Court, will sell to the highest bidder for cash at 11:00 a.m. online at [www.pasco.realforeclose.com](http://www.pasco.realforeclose.com) on the 14th day of April, 2014 the following described real property as set forth in said Final Summary Judgment, to wit:

LOT 839, BEACON WOODS VILLAGE 9-B, ACCORDING TO THE MAP OF PLAT THEREOF, AS RECORDED IN PLAT BOOK 14 PAGES 34-35, OF THE PUBLIC RECORDS OF PASCO COUNTY, FLORIDA.

If you are a person claiming a right to funds remaining after the sale, you must file a claim with the clerk no later than 60 days after the sale. If you fail to file a claim you will not be entitled to any remaining funds. After 60 days, only the owner of record as of the date of the lis pendens may claim the surplus.

IN ACCORDANCE WITH THE AMERICANS WITH DISABILITIES ACT, If you are a person with a disability who needs any accommodation in order to participate in this proceeding, you are entitled at no cost to you, to the provision of certain assistance. Please contact: Public Information Dept., Pasco County Government Center, 7530 Little Rd., New Port Richey, FL 34654; (727) 847-8110 (voice) for proceedings in New Port Richey; (352) 521-4274, ext 8110 (voice) for proceedings in Dade City at least 7 days before your scheduled court appearance, or immediately upon receiving this notification if the time before the scheduled appearance is less than 7 days; if you are hearing or voice impaired, call 711.  
Dated this 19 day of March, 2014.

By: /s/ Melody A. Martinez  
FBN 124151  
for Joshua Sabet, Esquire  
Fla. Bar No.: 85356  
Primary Email:  
[JSabet@ErwLaw.com](mailto:JSabet@ErwLaw.com)  
Secondary Email:  
[doservice@erwlaw.com](mailto:doservice@erwlaw.com)  
Elizabeth R. Wellborn, P.A.  
350 Jim Moran Blvd. Suite 100  
Deerfield Beach, FL 33442  
Telephone: (954) 354-3544  
Facsimile: (954) 354-3545  
FILE # 2012-03582  
Mar. 28; Apr. 4, 2014 14-01884P



## SECOND INSERTION

NOTICE OF RESCHEDULED FORECLOSURE SALE IN THE CIRCUIT COURT OF THE SIXTH JUDICIAL CIRCUIT IN AND FOR PASCO COUNTY, FLORIDA CIVIL ACTION

CASE NO.: 51-2009-CA-010596-WS  
DIVISION: J2

**BAC HOME LOANS SERVICING, LP F/K/A COUNTRYWIDE HOME LOANS SERVICING, L.P., Plaintiff, vs. CHRISTOPHER J. RADO, et al, Defendant(s).**

NOTICE IS HEREBY GIVEN pursuant to an Order Rescheduling Foreclosure Sale dated March 20, 2014 and entered in Case No. 51-2009-CA-010596-WS of the Circuit Court of the SIXTH Judicial Circuit in and for Pasco County, Florida wherein BAC HOME LOANS SERVICING, LP F/K/A COUNTRYWIDE HOME LOANS SERVICING, L.P., is the Plaintiff and CHRISTOPHER J. RADO; NICOLE M. RADO; MORTGAGE ELECTRONIC REGISTRATION SYSTEMS INCORPORATED AS NOMINEE FOR BAC HOME LOANS SERVICING, LP; WATERS EDGE SINGLE FAMILY HOMEOWNERS ASSOCIATION, INC.; WATERS EDGE MASTER ASSOCIATION, INC.; are the Defendants, The Clerk will sell to the highest and best bidder for cash at WWW.PASCO.REALFORECLOSE.COM IN ACCORDANCE WITH CHAPTER 45 FLORIDA STATUTES at 11:00AM, on 04/24/2014, the following described property as set forth in said Final Judgment:

LOT 305, OF WATERS EDGE PHASE TWO, ACCORDING

TO THE PLAT THEREOF, AS RECORDED IN PLAT BOOK 52, PAGES 85 THROUGH 109, INCLUSIVE, OF THE PUBLIC RECORDS OF PASCO COUNTY, FLORIDA.

A/K/A 11152 OYSTER BAY CIRCLE, NEW PORT RICHEY, FL 34654

Any person claiming an interest in the surplus from the sale, if any, other than the property owner as of the date of the Lis Pendens must file a claim within sixty (60) days after the sale.

\*\*See Americans with Disabilities Act

"If you are a person with a disability who needs an accommodation in order to participate in this proceeding, you are entitled, at no cost to you, to the provision of certain assistance. Please contact:

Public Information Dept., Pasco County Government Center 7530 Little Rd. New Port Richey, FL 34654 Phone: 727.847.8110 (voice) in New Port Richey 352.521.4274, ext 8110 (voice) in Dade City Or 711 for the hearing impaired

Contact should be initiated at least seven days before the scheduled court appearance, or immediately upon receiving this notification if the time before the scheduled appearance is less than seven days."

By: J. Bennett Kitterman  
Florida Bar No. 98636

Ronald R Wolfe & Associates, P.L.  
P.O. Box 25018  
Tampa, Florida 33622-5018  
(813) 251-4766  
(813) 251-1541 Fax  
F09076099  
Mar. 28; Apr. 4, 2014 14-01889P

## SECOND INSERTION

NOTICE OF SALE IN THE CIRCUIT COURT OF THE SIXTH JUDICIAL CIRCUIT, IN AND FOR PASCO COUNTY, FLORIDA

CASE NO. 51-2012-CA-001425WS

**WELLS FARGO BANK, N.A.; Plaintiff, vs. MARY CAROL PERDUE, ET AL; Defendants**

NOTICE IS HEREBY GIVEN that, in accordance with the Final Judgment of Foreclosure dated MARCH 12, 2014 entered in Civil Case No. 51-2012-CA-001425WS of the Circuit Court of the SIXTH Judicial Circuit in and for Pasco County, Florida, wherein WELLS FARGO BANK, N.A., Plaintiff and MARY CAROL PERDUE, ET AL; are defendant(s). The Clerk will sell to the highest and best bidder for cash, AT WWW.PASCO.REALFORECLOSE.COM IN ACCORDANCE WITH CHAPTER 45, FLORIDA STATUTES, AT 11:00 AM, APRIL 24, 2014 the following described property as set forth in said Final Judgment, to-wit:

LOT 514, HILLDALE UNIT FOUR, ACCORDING TO THE MAP OR PLAT THEREOF AS RECORDED IN PLAT BOOK 15, PAGES 66 AND 67, PUBLIC RECORDS OF PASCO COUNTY, FLORIDA.

Property Address: 7806 WICKLOW ST., NEW PORT RICHEY, FL 34653

ANY PERSON CLAIMING AN INTEREST IN THE SURPLUS FROM THE SALE, IF ANY, OTHER THAN THE PROPERTY OWNER AS OF

THE DATE OF THE LIS PENDENS MUST FILE A CLAIM WITHIN 60 DAYS AFTER THE SALE.

If you are a person with a disability who needs any accommodation in order to participate in this proceeding, you are entitled, at no cost to you, to the provision of certain assistance. Please contact the Public Information Dept., Pasco County Government Center, 7530 Little Rd., New Port Richey, FL 34654; (727) 847-8110 (V) in New Port Richey; (352) 521-4274, ext 8110 (V) in Dade City, at least 7 days before your scheduled court appearance, or immediately upon receiving this notification if the time before the scheduled appearance is less than 7 days; if you are hearing impaired call 711. The court does not provide transportation and cannot accommodate for this service. Persons with disabilities needing transportation to court should contact their local public transportation providers for information regarding transportation services.

DATED this 24 day of March, 2014.  
Keith Lehman, Esq.  
FBN. 85111

Attorneys for Plaintiff  
Marinosci Law Group, P.C.  
100 West Cypress Creek Road,  
Suite 1045  
Fort Lauderdale, FL 33309  
Phone: (954)-644-8704;  
Fax (954) 772-9601  
ServiceFL@mlg-defaultlaw.com  
ServiceFL2@mlg-defaultlaw.com  
11-08338  
Mar. 28; Apr. 4, 2014 14-01870P

## SECOND INSERTION

NOTICE OF SALE IN THE CIRCUIT COURT OF THE SIXTH JUDICIAL CIRCUIT IN AND FOR PASCO COUNTY, FLORIDA CIVIL DIVISION

CASE #: 51-2012-CA-000500-ES (J1)

**Wells Fargo Bank, NA Plaintiff, vs. William Loubriel and Sonia Loubriel, Husband and Wife; GTE Federal Credit Union; Ballantrae Homeowners Association, Inc.; Unknown Parties in Possession #1, If living, and all Unknown Parties claiming by, through, under and against the above named Defendant(s) who are not known to be dead or alive, whether said Unknown Parties may claim an interest as Spouse, Heirs, Devisees, Grantees, or Other Claimants; Unknown Parties in Possession #2, If living, and all Unknown Parties claiming by, through, under and against the above named Defendant(s) who are not known to be dead or alive, whether said Unknown Parties may claim an interest as Spouse, Heirs, Devisees, Grantees, or Other Claimants Defendant(s).**

NOTICE IS HEREBY GIVEN pursuant to an Order Rescheduling foreclosure sale, entered in Civil Case No. 51-2012-CA-000500-ES (J1) of the Circuit Court of the 6th Judicial Circuit in and for Pasco County, Florida, wherein Wells Fargo Bank, NA, Plaintiff and William Loubriel and Sonia Loubriel, Husband and Wife are defendant(s), I, Clerk of Court, Paula S. O'Neil, will sell to the highest and best bidder for cash

In an online sale accessed through the Clerk's website at www.pasco.realforeclose.com, at 11:00 a.m. on April 28, 2014, the following described property as set forth in said Final Judgment, to-wit:

LOT 2, BLOCK 19, BALLANTRAE VILLAGE 1, ACCORDING TO THE MAP OR PLAT THEREOF, AS RECORDED IN PLAT BOOK 51, PAGES 53-66, INCLUSIVE, OF THE PUBLIC RECORDS OF PASCO COUNTY, FLORIDA.

ANY PERSON CLAIMING AN INTEREST IN THE SURPLUS FROM THE SALE, IF ANY, OTHER THAN THE PROPERTY OWNER AS OF THE DATE OF THE LIS PENDENS MUST FILE A CLAIM WITHIN 60 DAYS AFTER THE SALE.

If you are a person with a disability who needs any accommodation in order to participate in this proceeding, you are entitled, at no cost to you, to the provision of certain assistance. Please contact the ADA Coordinator; 14250 49th Street North, Clearwater, Florida 33762 (727) 453-7163 at least 7 days before your scheduled court appearance, or immediately upon receiving this notification of the time before the scheduled appearance is less than 7 days. If you are hearing or voice impaired, call 711.

Submitted By:  
ATTORNEY FOR PLAINTIFF:  
SHAPIRO, FISHMAN & GACHÉ, LLP  
2424 North Federal Highway,  
Suite 360  
Boca Raton, Florida 33431  
(561) 998-6700  
(561) 998-6707  
11-231764 FCO1 WNI  
Mar. 28; Apr. 4, 2014 14-01869P

## SECOND INSERTION

NOTICE OF RESCHEDULED FORECLOSURE SALE IN THE CIRCUIT COURT OF THE SIXTH JUDICIAL CIRCUIT IN AND FOR PASCO COUNTY, FLORIDA CIVIL ACTION

CASE NO.: 51-2011-CA-002970WS

**WELLS FARGO BANK, NA, Plaintiff, vs. MICHAEL FLORIO A/K/A MICHAEL A. FLORIO, et al, Defendant(s).**

NOTICE IS HEREBY GIVEN pursuant to an Order Rescheduling Foreclosure Sale dated March 20, 2014 and entered in Case No. 51-2011-CA-002970WS of the Circuit Court of the SIXTH Judicial Circuit in and for Pasco County, Florida wherein WELLS FARGO BANK, NA, is the Plaintiff and MICHAEL FLORIO A/K/A MICHAEL A. FLORIO; CITIBANK, FEDERAL SAVINGS BANK SUCCESSOR BY MERGER TO CITIBANK, NATIONAL ASSOCIATION; TRINITY COMMUNITIES MASTER ASSOCIATION, INC.; FOX WOOD AT TRINITY COMMUNITY ASSOCIATION, INC.; AMERICAN EXPRESS CENTURION BANK; DISCOVER BANK; are the Defendants, The Clerk will sell to the highest and best bidder for cash at WWW.PASCO.REALFORECLOSE.COM IN ACCORDANCE WITH CHAPTER 45 FLORIDA STATUTES at 11:00AM, on 04/23/2014, the following described property as set forth in said Final Judgment:

LOT 494, FOX WOOD, PHASE FOUR, ACCORDING TO THE

MAP OR PLAT THEREOF, AS RECORDED IN PLAT BOOK 38, PAGES 50 THROUGH 56, INCLUSIVE, OF THE PUBLIC RECORDS OF PASCO COUNTY, FLORIDA

A/K/A 2112 BLUE BEECH COURT, TRINITY, FL 34655

Any person claiming an interest in the surplus from the sale, if any, other than the property owner as of the date of the Lis Pendens must file a claim within sixty (60) days after the sale.

\*\*See Americans with Disabilities Act

"If you are a person with a disability who needs an accommodation in order to participate in this proceeding, you are entitled, at no cost to you, to the provision of certain assistance. Please contact:

Public Information Dept., Pasco County Government Center 7530 Little Rd. New Port Richey, FL 34654 Phone: 727.847.8110 (voice) in New Port Richey 352.521.4274, ext 8110 (voice) in Dade City Or 711 for the hearing impaired

Contact should be initiated at least seven days before the scheduled court appearance, or immediately upon receiving this notification if the time before the scheduled appearance is less than seven days."

By: Matthew Wolf  
Florida Bar No. 92611

Ronald R Wolfe & Associates, P.L.  
P.O. Box 25018  
Tampa, Florida 33622-5018  
(813) 251-4766  
(813) 251-1541 Fax  
F11000512  
Mar. 28; Apr. 4, 2014 14-01890P

## SECOND INSERTION

NOTICE OF SALE IN THE CIRCUIT COURT OF THE SIXTH JUDICIAL CIRCUIT IN AND FOR PASCO COUNTY, FLORIDA

CASE NO. 51-2009-CA-010844WS

**US BANK, N.A. Plaintiff, v. MARIBEL STEWART; RAFAELA CALDERON; UNKNOWN SPOUSE OF MARIBEL STEWART; UNKNOWN SPOUSE OF RAFAELA CALDERON; UNKNOWN TENANT 1; UNKNOWN TENANT 2; AND ALL UNKNOWN PARTIES CLAIMING BY, THROUGH, UNDER OR AGAINST THE ABOVE NAMED DEFENDANT(S), WHO (IS/ARE) NOT KNOWN TO BE DEAD OR ALIVE, WHETHER SAID UNKNOWN PARTIES CLAIM AS HEIRS, DEVISEES, GRANTEEES, ASSIGNEES, LIENORS, CREDITORS, TRUSTEES, SPOUSES, OR OTHER CLAIMANTS; HOUSING FINANCE AUTHORITY OF PINELLAS COUNTY, AN AGENCY AND INSTRUMENTALITY OF THE COUNTY OF PINELLAS, FLORIDA Defendants.**

Notice is hereby given that, pursuant to the Summary Final Judgment of Foreclosure entered on April 11, 2012, and the Order Rescheduling Foreclosure Sale entered on March 12, 2014, in this cause, in the Circuit Court of Pasco County, Florida, the clerk shall sell the property situated in Pasco County, Florida, described as:

LOT 41, COLONIAL MANOR UNIT ONE, ACCORDING TO THE PLAT THEREOF, AS RECORDED IN PLAT BOOK 8, PAGE 12, OF THE PUBLIC RECORDS OF PASCO COUNTY, FLORIDA.

a/k/a 3549 LATIMER STREET, NEW PORT RICHEY, FL 34652 at public sale, to the highest and best bidder, for cash, online at www.pasco.realforeclose.com, on April 17, 2014 beginning at 11:00 AM.

If you are a person claiming a right to funds remaining after the sale, you must file a claim with the clerk no later than 60 days after the sale. If you fail to file a claim you will not be entitled to any remaining funds.

ANY PERSONS WITH A DISABILITY REQUIRING REASONABLE ACCOMMODATIONS SHOULD CALL NEW PORT RICHEY (813) 847-8110; DADE CITY (352) 521-4274 EXT 8110; TDD 1-800-955-8771 VIA FLORIDA RELAY SERVICE, NO LATER THAN SEVEN (7) DAYS PRIOR TO ANY PROCEEDING.

Dated at St. Petersburg, Florida, this 24th day of March 2014.  
By: /s/ Angela L. Leiner, Esquire  
Angela L. Leiner  
FBN #85112

Douglas C. Zahm, P.A.  
Designated Email Address:  
efiling@dczahm.com  
12425 28th Street North, Suite 200  
St. Petersburg, FL 33716  
Telephone No. (727) 536-4911  
Attorney for the Plaintiff  
665091212  
Mar. 28; Apr. 4, 2014 14-01872P

## SECOND INSERTION

NOTICE OF SALE PURSUANT TO CHAPTER 45 IN THE CIRCUIT COURT OF THE SIXTH JUDICIAL CIRCUIT IN AND FOR PASCO COUNTY, FLORIDA CIVIL ACTION

CASE NO.: 51-2013-CA-003361-CAAX-WS

**WELLS FARGO BANK, N.A., Plaintiff, vs. JAMES E. SPIKER, et al, Defendant(s).**

NOTICE IS HEREBY GIVEN Pursuant to a Final Judgment of Foreclosure dated February 26, 2014, and entered in Case No. 51-2013-CA-003361-CAAX-WS of the Circuit Court of the Sixth Judicial Circuit in and for Pasco County, Florida in which Wells Fargo Bank, N.A., is the Plaintiff and James E. Spiker also known as James Spiker, Kathleen D. Spiker also known as Kathleen Spiker, Tenant # 1 also known as Erica Spiker, Tenant # 2, The Unknown Spouse of James E. Spiker also known as James Spiker, The Unknown Spouse of Kathleen D. Spiker also known as Kathleen Spiker, are defendants, the Pasco County Clerk of the Circuit Court will sell to the highest and best bidder for cash in/on held online www.pasco.realforeclose.com: in Pasco County, Florida, Pasco County, Florida at 11:00AM on the 16th day of April 2014, the following described property as set forth in said Final Judgment of Foreclosure:

LOT 83, EAST GATE ESTATES, FIRST ADDITION, ACCORDING TO THE MAP OR PLAT THEREOF, AS RECORDED IN PLAT BOOK 7, PAGE 113, OF THE PUBLIC RECORDS OF PASCO COUNTY, FLORIDA. A/K/A 5534 BAKER RD NEW PORT RICHEY FL 34653-4506

Any person claiming an interest in the surplus from the sale, if any, other than the property owner as of the date of the Lis Pendens must file a claim within 60 days after the sale.

If you are a person with a disability who needs an accommodation in order to participate in this proceeding, you are entitled, at no cost to you, to the provision of certain assistance. Please contact:

Public Information Dept., Pasco County Government Center 7530 Little Rd. New Port Richey, FL 34654 Phone: 727.847.8110 (voice) in New Port Richey 352.521.4274, ext 8110 (voice) in Dade City Or 711 for the hearing impaired

Contact should be initiated at least seven days before the scheduled court appearance, or immediately upon receiving this notification if the time before the scheduled appearance is less than seven days.

The court does not provide transportation and cannot accommodate such requests. Persons with disabilities needing transportation to court should contact their local public transportation providers for information regarding transportation services.

Dated in Hillsborough County, Florida this 24th day of March, 2014.  
/s/ Erik Del'Etoile  
Erik Del'Etoile, Esq.  
FL Bar # 71675

Albertelli Law  
Attorney for Plaintiff  
P.O. Box 23028  
Tampa, FL 33623  
(813) 221-4743  
(813) 221-9171 facsimile  
eService:  
servealaw@albertellilaw.com  
BM - 018883F01  
Mar. 28; Apr. 4, 2014 14-01876P

## SECOND INSERTION

NOTICE OF FORECLOSURE SALE IN THE CIRCUIT COURT OF THE SIXTH JUDICIAL CIRCUIT IN AND FOR PASCO COUNTY, FLORIDA

GENERAL JURISDICTION DIVISION  
Case No.

**51-2011-CA-005352-XXXX-ES J1 CitiMortgage, Inc., Plaintiff, vs. Angela M. Echevarry a/k/a Angela Maria Echeverry; Juan Carlos Cardona; Lexington Oaks of Pasco County Homeowners Association, Inc.; Unknown Tenant#1; Unknown Tenant#2, Defendants.**

NOTICE IS HEREBY GIVEN pursuant to a Final Judgment of Foreclosure dated January 21, 2014, entered in Case No. 51-2011-CA-005352-XXXX-ES J1 of the Circuit Court of the Sixth Judicial Circuit in and for Pasco County, Florida, wherein CitiMortgage, Inc. is the Plaintiff and Angela M. Echevarry a/k/a Angela Maria Echeverry; Juan Carlos Cardona; Lexington Oaks of Pasco County Homeowners Association, Inc.; Unknown Tenant#1; Unknown Tenant#2 are the Defendants, that the Clerk of Courts will sell to the highest and best bidder for cash by electronic sale at www.pasco.realforeclose.com, beginning at 11:00 AM on the 22nd day of April, 2014, the following described property as set forth in said Final Judgment, to wit:

LOT 12, BLOCK 15, LEXINGTON OAKS, VILLAGE 13, UNIT A AND B, ACCORDING

TO THE PLAT THEREOF AS RECORDED IN PLAT BOOK 38, PAGES 80 THROUGH 82 OF THE PUBLIC RECORDS OF PASCO COUNTY, FLORIDA.

If you are a person with a disability who needs any accommodation in order to participate in this proceeding, you are entitled, at no cost to you, to the provision of certain assistance. Please contact the Public Information Dept., Pasco County Government Center, 7530 Little Rd., New Port Richey, FL 34654; (727) 847-8110 (V) in New Port Richey; (352) 521-4274, ext 8110 (V) in Dade City, at least 7 days before your scheduled court appearance, or immediately upon receiving this notification if the time before the scheduled appearance is less than 7 days; if you are hearing impaired call 711. The court does not provide transportation and cannot accommodate for this service. Persons with disabilities needing transportation to court should contact their local public transportation providers for information regarding transportation services.

Dated this 25 day of March, 2014.

By Kathleen McCarthy, Esq.  
Florida Bar No. 72161

BROCK & SCOTT, PLLC  
Attorney for Plaintiff  
1501 N.W. 49th Street, Suite 200  
Ft. Lauderdale, FL 33309  
Phone: (954) 618-6955, ext. 6177  
Fax: (954) 618-6954  
FLCourtDocs@brockandscott.com  
11-F01170  
Mar. 28; Apr. 4, 2014 14-01895P

## SECOND INSERTION

NOTICE OF SALE PURSUANT TO CHAPTER 45 IN THE CIRCUIT COURT OF THE SIXTH JUDICIAL CIRCUIT IN AND FOR PASCO COUNTY, FLORIDA CIVIL ACTION

CASE NO.: 51-2012-CA-002966-CAAX-WS

**WELLS FARGO BANK, NA, Plaintiff, vs. MORGAN, JOHN et al, Defendant(s).**

NOTICE IS HEREBY GIVEN Pursuant to a Final Judgment of Foreclosure dated February 26, 2014, and entered in Case No. 51-2012-CA-002966-CAAX-WS of the Circuit Court of the Sixth Judicial Circuit in and for Pasco County, Florida in which Wells Fargo Bank, NA, is the Plaintiff and GTE Federal Credit Union, John Morgan, Lori Morgan, are defendants, the Pasco County Clerk of the Circuit Court will sell to the highest and best bidder for cash in/on held online www.pasco.realforeclose.com: in Pasco County, Florida at 11:00AM on the 16th day of April, 2014, the following described property as set forth in said Final Judgment of Foreclosure:

LOT 2341, BEACON SQUARE UNIT 19, ACCORDING TO THE MAP OR PLAT THEREOF AS RECORDED IN PLAT BOOK 10 PAGE 94, PUBLIC RECORDS OF PASCO COUNTY, FLORIDA.

3825 HAVEN DR, NEW PORT RICHEY, FL 34652-5721

Any person claiming an interest in the surplus from the sale, if any, other than the property owner as of the date of the Lis Pendens must file a claim within 60

days after the sale.

If you are a person with a disability who needs an accommodation in order to participate in this proceeding, you are entitled, at no cost to you, to the provision of certain assistance. Please contact:

Public Information Dept., Pasco County Government Center 7530 Little Rd. New Port Richey, FL 34654 Phone: 727.847.8110 (voice) in New Port Richey 352.521.4274, ext 8110 (voice) in Dade City Or 711 for the hearing impaired

Contact should be initiated at least seven days before the scheduled court appearance, or immediately upon receiving this notification if the time before the scheduled appearance is less than seven days.

The court does not provide transportation and cannot accommodate such requests. Persons with disabilities needing transportation to court should contact their local public transportation providers for information regarding transportation services.

Dated in Hillsborough County, Florida, this 24th day of March, 2014  
/s/ Erik Del'Etoile  
Erik Del'Etoile, Esq.  
FL Bar # 71675

Albertelli Law  
Attorney for Plaintiff  
P.O. Box 23028  
Tampa, FL 33623  
(813) 221-4743  
(813) 221-9171 facsimile  
eService:  
servealaw@albertellilaw.com  
BM - 006874F01  
Mar. 28; Apr. 4, 2014 14-01878P

## SECOND INSERTION

NOTICE OF SALE PURSUANT TO CHAPTER 45 IN THE CIRCUIT COURT OF THE SIXTH JUDICIAL CIRCUIT IN AND FOR PASCO COUNTY, FLORIDA CIVIL ACTION

CASE NO.: 51-2012-CA-008245-CAAX-WS

**JPMORGAN CHASE BANK, NATIONAL ASSOCIATION, Plaintiff, vs. BAHR, MICHAEL N. et al, Defendant(s).**

NOTICE IS HEREBY GIVEN Pursuant to a Final Judgment of Foreclosure dated February 26, 2014, and entered in Case No. 51-2012-CA-008245-CAAX-WS of the Circuit Court of the Sixth Judicial Circuit in and for Pasco County, Florida in which JPMorgan Chase Bank, National Association, is the Plaintiff and Lakeside Community Association, Inc., Michael N. Bahr, Natalie C. Bahr, are defendants, the Pasco County Clerk of the Circuit Court will sell to the highest and best bidder for cash in/on held online www.pasco.realforeclose.com: in Pasco County, Florida, Pasco County, Florida at 11:00AM on the 16th day of April, 2014, the following described property as set forth in said Final Judgment of Foreclosure:

LOT 121, LAKESIDE PHASE 1A, 2A & 5, ACCORDING TO THE PLAT THEREOF AS RECORDED IN PLAT BOOK 61, PAGES 27 THROUGH 62, OF THE PUBLIC RECORDS OF PASCO COUNTY, FLORIDA.

13945 CRATER CIR, HUDSON, FL 34669-1182

Any person claiming an interest in the surplus from the sale, if any,

other than the property owner as of the date of the Lis Pendens must file a claim within 60 days after the sale.

If you are a person with a disability who needs an accommodation in order to participate in this proceeding, you are entitled, at no cost to you, to the provision of certain assistance. Please contact:

Public Information Dept., Pasco County Government Center 7530 Little Rd. New Port Richey, FL 34654 Phone: 727.847.8110 (voice) in New Port Richey 352.521.4274, ext 8110 (voice) in Dade City Or 711 for the hearing impaired

Contact should be initiated at least seven days before the scheduled court appearance, or immediately upon receiving this notification if the time before the scheduled appearance is less than seven days.

The court does not provide transportation and cannot accommodate such requests. Persons with disabilities needing transportation to court should contact their local public transportation providers for information regarding transportation services.

Dated in Hillsborough County, Florida, this 24th day of March, 2014  
/s/ Erik Del'Etoile  
Erik Del'Etoile, Esq.  
FL Bar # 71675

Albertelli Law  
Attorney for Plaintiff  
P.O. Box 23028  
Tampa, FL 33623  
(813) 221-4743  
(813) 221-9171 facsimile  
eService:  
servealaw@albertellilaw.com  
BM - 003558F01  
Mar. 28; Apr. 4, 2014 14-01877P

## SECOND INSERTION

NOTICE OF SALE  
IN THE CIRCUIT COURT OF  
THE SIXTH JUDICIAL CIRCUIT  
OF THE STATE OF FLORIDA, IN  
AND FOR PASCO COUNTY  
CIVIL DIVISION

**CASE NO. 51-2012-CA-005863-XXXX-WS**  
**BANK OF AMERICA, NATIONAL ASSOCIATION, Plaintiff, vs. MICHAEL R. HUDSON; UNKNOWN SPOUSE OF MICHAEL R. HUDSON; UNKNOWN TENANT #1; UNKNOWN TENANT #2; Defendant(s)**

Notice is hereby given that, pursuant to a Final Summary Judgment of Foreclosure entered on 02/19/2014 in the above-styled cause, in the Circuit Court of Pasco County, Florida, the office of Paula S. O'Neil clerk of the circuit court will sell the property situate in Pasco County, Florida, described as:

LOT 6, BLOCK 124, REVISED PLAT OF THE TOWN OF NEW PORT RICHEY, ACCORDING TO THE PLAT THEREOF, AS RECORDED IN PLAT BOOK 4, PAGE 49, OF THE PUBLIC RECORDS OF PASCO COUNTY, FLORIDA

at public sale, to the highest and best bidder, for cash, [www.pasco.realforeclose.com](http://www.pasco.realforeclose.com) at 11:00 o'clock, A.M., on April 16, 2014

Any person claiming an interest in the surplus from the sale, if any, other than the property owner as of the date of the lis pendens, must file a claim within 60 days after the sale.

If you are a person with a disability who needs any accommodation in order to participate in this proceeding, you are entitled, at no cost to you, to the provision of certain assistance. Please contact the Public Information Dept., Pasco County Government

Center, 7530 Little Rd., New Port Richey, FL 34654; (727) 847-8110 (V) for proceedings in New Port Richey; (352) 521-4274, ext. 8110 (V) for proceedings in Dade City, at least 7 days before your scheduled court appearance, or immediately upon receiving this notification if the time before the scheduled appearance is less than 7 days; if you are hearing impaired call 711.

Date: 03/25/2014  
ATTORNEY FOR PLAINTIFF  
By /s/ Josh D. Donnelly  
Josh D. Donnelly  
Florida Bar #64788

THIS INSTRUMENT PREPARED BY:  
Law Offices of Daniel C. Consuegra  
9204 King Palm Drive  
Tampa, FL 33619-1328  
Phone: 813-915-8660  
Attorneys for Plaintiff  
131889  
Mar. 28; Apr. 4, 2014 14-01900P

## SECOND INSERTION

NOTICE OF SALE  
UNDER F.S. CHAPTER 45  
IN THE CIRCUIT COURT OF THE  
SIXTH JUDICIAL CIRCUIT IN AND  
FOR PASCO COUNTY, FLORIDA

**CASE NO. 51-2013-CA-003976-CAAX-ES**  
**U.S. BANK, NATIONAL ASSOCIATION, AS TRUSTEE FOR CVF II MORTGAGE LOAN TRUST I, Plaintiff, vs. MARIA ALVAREZ, et al., Defendants.**

NOTICE IS GIVEN that, in accordance with the Final Judgment of Foreclosure dated March 11, 2014, in the above-styled cause, I will sell to the highest and best bidder for cash at <https://www.pasco.realforeclose.com>, on April 28, 2014, at 11:00 a.m., the following described property:

LOT 20, BLOCK 35, MEADOW POINTE III PARCEL "DD" &

"Y", AS PER PLAT THEREOF, RECORDED IN PLAT BOOK 59, PAGE 123-141, OF THE PUBLIC RECORDS OF PASCO COUNTY, FLORIDA.

ANY PERSON CLAIMING AN INTEREST IN THE SURPLUS FROM THE SALE, IF ANY, OTHER THAN THE PROPERTY OWNER AS OF THE DATE OF THE LIS PENDENS MUST FILE A CLAIM WITHIN 60 DAYS AFTER THE SALE.

If you are a person with a disability who needs any accommodation in order to participate in this proceeding, you are entitled, at no cost to you, to the provision of certain assistance. Please contact the Public Information Dept., Pasco County Government Center, 7530 Little Rd., New Port Richey, FL 34654; (727) 847-8110 (V) in New Port Richey; (352) 521-4274, ext 8110 (V) in Dade City, at least 7 days before your scheduled court appear-

ance, or immediately upon receiving this notification if the time before the scheduled appearance is less than 7 days; if you are hearing impaired call 711. The court does not provide transportation and cannot accommodate for this service. Persons with disabilities needing transportation to court should contact their local public transportation providers for information regarding transportation services.

By: /s/ Ira Scot Silverstein, Esq.  
Ira Scot Silverstein, Esq.  
FBN: 0009636

IRA SCOT SILVERSTEIN, LLC.  
ATTORNEYS FOR PLAINTIFF  
2900 West Cypress Creek Road,  
Suite 6  
Fort Lauderdale, FL 33309  
(954) 773-9911  
(954) 369-5034 fax  
ira@isslawyer.com  
124.198 (Fay Servicing/Alvarez)  
Mar. 28; Apr. 4, 2014 14-01918P

## SECOND INSERTION

NOTICE OF FORECLOSURE SALE  
IN THE CIRCUIT COURT OF THE  
SIXTH JUDICIAL CIRCUIT, IN AND  
FOR PASCO COUNTY, FLORIDA  
CIVIL DIVISION

**CASE NO. 51-2012-CA-002561ES**  
**THE BANK OF NEW YORK MELLON FKA THE BANK OF NEW YORK AS TRUSTEE FOR THE CERTIFICATEHOLDERS OF THE CWABS, INC., ASSET-BACKED CERTIFICATES, SERIES 2005-12 Plaintiff, vs. AMY M. RICHARDS JAMES ROSS RICHARDS, et al., Defendants.**

NOTICE IS HEREBY GIVEN pursuant to an Order of Final Judgment entered in Case No. 51-2012-CA-002561ES in the Circuit Court of the SIXTH Judicial Circuit in and for PASCO County, Florida, wherein, THE BANK OF NEW YORK MELLON FKA THE BANK OF NEW YORK AS TRUSTEE FOR THE CERTIFICATEHOLDERS OF THE CWABS, INC., ASSET-BACKED CERTIFICATES, SERIES 2005-12, Plaintiff, and, AMY M. RICHARDS JAMES ROSS RICHARDS, et al., are Defendants. The Clerk of Court will sell to the highest bidder for cash online at [www.pasco.realforeclose.com](http://www.pasco.realforeclose.com) at the hour of 11:00AM, on the 23rd day of April, 2014, the following described property:

THE NORTH 110.00 FEET OF TRACT 99, IN SECTION 4, TOWNSHIP 26 SOUTH, RANGE 21 EAST, ZEPHYRHILLS COLONY COMPANY LANDS, AS PER PLAT THEREOF RECORDED IN PLAT BOOK 1, PAGE 55, PUBLIC RECORDS OF PASCO COUNTY, FLORIDA, LESS THE EAST 479.00 FEET THEREOF, SUBJECT TO AN EASEMENT OVER AND ACROSS THE EAST 25 FEET THEREOF FOR INGRESS AND EGRESS. AND THE NORTH 1/2 OF THE

SOUTH 125.00 FEET OF THE NORTH 235 FEET OF TRACT 99, ZEPHYRHILLS COLONY COMPANY LANDS IN SECTION 4, TOWNSHIP 26 SOUTH, RANGE 21 EAST, AS RECORDED IN PLAT BOOK 1, PAGE 55, PUBLIC RECORDS OF PASCO COUNTY, FLORIDA, LESS THE EAST 479 FEET THEREOF, SUBJECT TO EASEMENT OVER AND ACROSS THE EAST 25 FEET FOR INGRESS AND EGRESS.

Any person claiming an interest in the surplus from the sale, if any, other than the property owner as of the date of the Lis Pendens must file a claim within 60 days after the sale.

IMPORTANT  
If you are a person with a disability who needs any accommodation in order to participate in this proceeding, you are entitled, at no cost to you, to the provision of certain assistance. Within two (2) working days of your receipt of this (describe notice/order) please contact the Public Information Dept., Pasco County Government Center, 7530 Little Rd., New Port Richey, FL 34654; (727) 8478110 (V) in New Port Richey; (352) 521-4274, ext. 8110 (V) in Dade City; via 1-800-955-8771 if you are hearing impaired. The court does not provide transportation and cannot accommodate for this service. Persons with disabilities needing transportation to court should contact their local public transportation providers for information regarding disabled transportation services.

DATED this 25 day of March, 2014.  
MATTHEW B. KLEIN, ESQ.  
FL BAR NO. 73529

MILLENNIUM PARTNERS  
Attorneys for Plaintiff  
Primary E-Mail Address:  
service@millenniumpartners.net  
14750 NW 77th Court, Suite 303  
Telephone: (305) 698-5839  
Facsimile: (305) 698-5840  
MP# 11-002112  
Mar. 28; Apr. 4, 2014 14-01891P

## SECOND INSERTION

NOTICE OF SALE  
IN THE CIRCUIT COURT OF  
THE SIXTH JUDICIAL CIRCUIT  
OF THE STATE OF FLORIDA, IN  
AND FOR PASCO COUNTY  
CIVIL DIVISION

**CASE NO. 51-2011-CA-002142-CAAX-ES**  
**NATIONSTAR MORTGAGE, LLC, Plaintiff, vs. SCOTT MICHAEL PADGETT A/K/A SCOTT M. PADGETT; UNKNOWN SPOUSE OF SCOTT MICHAEL PADGETT A/K/A SCOTT M. PADGETT; JULIE PATRICIA GIBSON A/K/A JULIE P. GIBSON; UNKNOWN SPOUSE OF JULIE PATRICIA GIBSON A/K/A JULIE P. GIBSON; IF LIVING, INCLUDING ANY UNKNOWN SPOUSE OF SAID DEFENDANT(S), IF REMARRIED, AND IF DECEASED, THE RESPECTIVE UNKNOWN HEIRS, DEVISEES, GRANTEES, ASSIGNEES, CREDITORS, LIENORS, AND TRUSTEES, AND ALL OTHER PERSONS CLAIMING BY, THROUGH, UNDER OR AGAINST THE NAMED DEFENDANT(S); GTE FEDERAL CREDIT UNION; OAK CREEK OF PASCO COUNTY HOMEOWNER'S ASSOCIATION, INC.; WHETHER DISSOLVED OR PRESENTLY EXISTING, TOGETHER WITH ANY GRANTEES, ASSIGNEES, CREDITORS, LIENORS, OR TRUSTEES OF SAID DEFENDANT(S) AND ALL OTHER PERSONS CLAIMING BY, THROUGH, UNDER, OR AGAINST DEFENDANT(S); UNKNOWN TENANT #1; UNKNOWN TENANT #2; Defendant(s)**

Notice is hereby given that, pursuant to a Final Summary Judgment of Foreclosure entered on 12/17/2013 in the above-styled cause, in the Circuit Court of Pasco County, Florida, the office of Paula S. O'Neil clerk of the circuit court

will sell the property situate in Pasco County, Florida, described as:

LOT 218, OAK CREEK PHASE ONE, ACCORDING TO THE PLAT THEREOF, AS RECORDED IN PLAT BOOK 53, PAGES 40 THROUGH 50, OF THE PUBLIC RECORDS OF PASCO COUNTY, FLORIDA.

at public sale, to the highest and best bidder, for cash, [www.pasco.realforeclose.com](http://www.pasco.realforeclose.com) at 11:00 o'clock, A.M., on April 16, 2014

Any person claiming an interest in the surplus from the sale, if any, other than the property owner as of the date of the lis pendens, must file a claim within 60 days after the sale.

If you are a person with a disability who needs any accommodation in order to participate in this proceeding, you are entitled, at no cost to you, to the provision of certain assistance. Please contact the Public Information Dept., Pasco County Government Center, 7530 Little Rd., New Port Richey, FL 34654; (727) 847-8110 (V) for proceedings in New Port Richey; (352) 521-4274, ext. 8110 (V) for proceedings in Dade City, at least 7 days before your scheduled court appearance, or immediately upon receiving this notification if the time before the scheduled appearance is less than 7 days; if you are hearing impaired call 711.

Date: 03/25/2014  
ATTORNEY FOR PLAINTIFF  
By /s/ Josh D. Donnelly  
Josh D. Donnelly  
Florida Bar #64788

THIS INSTRUMENT PREPARED BY:  
Law Offices of Daniel C. Consuegra  
9204 King Palm Drive  
Tampa, FL 33619-1328  
Phone: 813-915-8660  
Attorneys for Plaintiff  
89405  
Mar. 28; Apr. 4, 2014 14-01897P

## SECOND INSERTION

NOTICE OF SALE  
IN THE CIRCUIT COURT OF  
THE SIXTH JUDICIAL CIRCUIT  
OF THE STATE OF FLORIDA, IN  
AND FOR PASCO COUNTY  
CIVIL DIVISION

**CASE NO. 51-2011-CA-003301-CAAX-WS**  
**FEDERAL NATIONAL MORTGAGE ASSOCIATION, Plaintiff, vs. JENNIFER R. WOJTECKI A/K/A JENNIFER WOJTECKI; UNKNOWN SPOUSE OF JENNIFER R. WOJTECKI A/K/A JENNIFER WOJTECKI; STEVEN W. WOJTECKI A/K/A STEVE WOJTECKI; UNKNOWN SPOUSE OF STEVEN W. WOJTECKI A/K/A STEVE WOJTECKI; IF LIVING, INCLUDING ANY UNKNOWN SPOUSE OF SAID DEFENDANT(S), IF REMARRIED, AND IF DECEASED, THE RESPECTIVE UNKNOWN HEIRS, DEVISEES, GRANTEES, ASSIGNEES, CREDITORS, LIENORS, AND TRUSTEES, AND ALL OTHER PERSONS CLAIMING BY, THROUGH, UNDER OR AGAINST THE NAMED DEFENDANT(S); BEACON WOODS EAST HOMEOWNERS ASSOCIATION, INC; BEACON WOODS EAST MASTER ASSOCIATION, INC; WHETHER DISSOLVED OR PRESENTLY EXISTING, TOGETHER WITH ANY GRANTEES, ASSIGNEES, CREDITORS, LIENORS, OR TRUSTEES OF SAID DEFENDANT(S) AND ALL OTHER PERSONS CLAIMING BY, THROUGH, UNDER, OR AGAINST DEFENDANT(S); UNKNOWN TENANT #1; UNKNOWN TENANT #2; Defendant(s)**

Notice is hereby given that, pursuant to a Final Summary Judgment of Foreclosure entered on 02/19/2014 in the

above-styled cause, in the Circuit Court of Pasco County, Florida, the office of Paula S. O'Neil clerk of the circuit court will sell the property situate in Pasco County, Florida, described as:

LOT 767, WOODWARD VILLAGE UNIT 2-B, ACCORDING TO THE PLAT THEREOF, AS RECORDED IN PLAT BOOK 22, PAGES 11 AND 12, OF THE PUBLIC RECORDS OF PASCO COUNTY, FLORIDA.

at public sale, to the highest and best bidder, for cash, [www.pasco.realforeclose.com](http://www.pasco.realforeclose.com) at 11:00 o'clock, A.M., on April 17, 2014

Any person claiming an interest in the surplus from the sale, if any, other than the property owner as of the date of the lis pendens, must file a claim within 60 days after the sale.

If you are a person with a disability who needs any accommodation in order to participate in this proceeding, you are entitled, at no cost to you, to the provision of certain assistance. Please contact the Public Information Dept., Pasco County Government Center, 7530 Little Rd., New Port Richey, FL 34654; (727) 847-8110 (V) for proceedings in New Port Richey; (352) 521-4274, ext. 8110 (V) for proceedings in Dade City, at least 7 days before your scheduled court appearance, or immediately upon receiving this notification if the time before the scheduled appearance is less than 7 days; if you are hearing impaired call 711.

Date: 03/25/2014  
ATTORNEY FOR PLAINTIFF  
By /s/ Josh D. Donnelly  
Josh D. Donnelly  
Florida Bar #64788

THIS INSTRUMENT PREPARED BY:  
Law Offices of Daniel C. Consuegra  
9204 King Palm Drive  
Tampa, FL 33619-1328  
Phone: 813-915-8660  
Attorneys for Plaintiff  
95896  
Mar. 28; Apr. 4, 2014 14-01906P

## SECOND INSERTION

NOTICE OF RESCHEDULED SALE  
IN THE CIRCUIT COURT OF THE  
SIXTH JUDICIAL CIRCUIT IN AND  
FOR PASCO COUNTY, FLORIDA  
CIVIL ACTION

**CASE NO. 51-2010-CA-000761-CAAX-WS**  
**WELLS FARGO BANK, NATIONAL ASSOCIATION, SUCCESSOR IN INTEREST TO WACHOVIA MORTGAGE, F.S.B. F/K/A WORLD SAVINGS BANK, F.S.B., Plaintiff, vs. GARY KNISLEY, et al, Defendant(s).**

NOTICE IS HEREBY GIVEN Pursuant to an Order Rescheduling Foreclosure Sale dated on or about February 19, 2014, and entered in Case No. 51-2010-CA-000761-CAAX-WS of the Circuit Court of the Sixth Judicial Circuit in and for Pasco County, Florida in which Wells Fargo Bank, National Association, successor in interest to Wachovia Mortgage, F.S.B. f/k/a World Savings Bank, F.S.B., is the Plaintiff and Gary Knisley, Cielo DePaula a/k/a Cielo DePaula a/k/a Celio DePaula, Gulf Harbors Beach Club, Inc., Gulf Landings Association, Inc., Leslie A. Rubin, Limited, Lindrick Service Corporation, United States of America, are defendants, the Pasco County Clerk of the Circuit Court will sell to the highest and best bidder for cash in/on held online [www.pasco.realforeclose.com](http://www.pasco.realforeclose.com): in Pasco County, Florida, Pasco County, Florida at 11:00AM on the 16th day of April, 2014, the following described property as set forth in said Final Judgment of Foreclosure:

LOT 162, OF GULF HARBORS SEA FOREST UNIT 1B, ACCORDING TO THE PLAT THEREOF, AS RECORDED IN PLAT BOOK 21, PAGES 128 THROUGH 131, OF THE PUBLIC RECORDS OF PASCO COUNTY, FLORIDA.

A/K/A 6400 GARLAND COURT, NEW PORT RICHEY, FL 34652

Any person claiming an interest in the surplus from the sale, if any, other than the property owner as of the date of the Lis Pendens must file a claim within 60 days after the sale.

If you are a person with a disability who needs an accommodation in order to participate in this proceeding, you are entitled, at no cost to you, to the provision of certain assistance. Please contact:

Public Information Dept., Pasco County Government Center 7530 Little Rd. New Port Richey, FL 34654 Phone: 727.847.8110 (voice) in New Port Richey 352.521.4274, ext 8110 (voice) in Dade City Or 711 for the hearing impaired

Contact should be initiated at least seven days before the scheduled court appearance, or immediately upon receiving this notification if the time before the scheduled appearance is less than seven days.

The court does not provide transportation and cannot accommodate such requests. Persons with disabilities needing transportation to court should contact their local public transportation providers for information regarding transportation services.

Dated in Hillsborough County, Florida on this 24th day of March, 2014.

/s/ Erik Del'Etoile  
Erik Del'Etoile, Esq.  
FL Bar # 71675

Albertelli Law  
Attorney for Plaintiff  
P.O. Box 23028  
Tampa, FL 33623  
(813) 221-4743  
(813) 221-9171 facsimile  
eService:  
servealaw@albertellilaw.com  
BM - 10-33236  
Mar. 28; Apr. 4, 2014 14-01880P

## SECOND INSERTION

NOTICE OF FORECLOSURE SALE  
IN THE CIRCUIT COURT OF THE  
SIXTH JUDICIAL CIRCUIT OF  
FLORIDA IN AND FOR PASCO  
COUNTY

GENERAL JURISDICTION  
DIVISION  
**CASE NO. 51-2012-CA-001634-CAAX-WS**

**THE BANK OF NEW YORK MELLON FKA THE BANK OF NEW YORK, AS TRUSTEE FOR THE CERTIFICATEHOLDERS OF CWABS, INC., ASSET-BACKED CERTIFICATES, SERIES 2007-4, Plaintiff, vs. JORGE FERNANDEZ, et al., Defendants.**

NOTICE IS HEREBY GIVEN pursuant to a Summary Final Judgment of Foreclosure entered March 5, 2014 in Civil Case No. 51-2012-CA-001634-CAAX-WS of the Circuit Court of the SIXTH Judicial Circuit in and for Pasco County, Dade City, Florida, wherein THE BANK OF NEW YORK MELLON FKA THE BANK OF NEW YORK, AS TRUSTEE FOR THE CERTIFICATEHOLDERS OF CWABS, INC., ASSET-BACKED CERTIFICATES, SERIES 2007-4 is Plaintiff and CATHALENA A CASPER-FERNANDEZ A/K/A CATHALENE A CASPER-FERNANDEZ, JORGE FERNANDEZ, UNKNOWN TENANT(S), are Defendants, the Clerk of Court will sell to the highest and best bidder for cash electronically at [www.pasco.realforeclose.com](http://www.pasco.realforeclose.com) in accordance with Chapter 45, Florida Statutes on the 23rd day of April, 2014 at 11:00 AM on the following described property as set forth in said Summary Final Judgment, to-wit:

All that certain parcel of land situate in the County of Pasco, State of Florida being known and designated as Lot 12, The

Meadows, according to the map or plat thereof, as the same is recorded in Plat Book 14, Pages 108-112 inclusive, of the Public Records of Pasco County, Florida

Any person claiming an interest in the surplus from the sale, if any, other than the property owner as of the date of the lis pendens, must file a claim within 60 days after the sale.

If you are a person with a disability who needs any accommodation in order to participate in this proceeding, you are entitled, at no cost to you, to the provision of certain assistance. Please contact the Public Information Dept., Pasco County Government Center, 7530 Little Rd., New Port Richey, FL 34654; (727) 847-8110 (V) in New Port Richey; (352) 521-4274, ext 8110 (V) in Dade City, at least 7 days before your scheduled court appearance, or immediately upon receiving this notification if the time before the scheduled appearance is less than 7 days; if you are hearing impaired call 711. The court does not provide transportation and cannot accommodate for this service. Persons with disabilities needing transportation to court should contact their local public transportation providers for information regarding transportation services.

Alllyson G Morgado  
FL Bar # 91506  
for Marie D. Campbell, Esq.  
Fla. Bar No.: 543357

McCalla Raymer, LLC  
Attorney for Plaintiff  
225 E. Robinson St. Suite 660  
Orlando, FL 32801  
Phone: (407) 674-1850  
Fax: (321) 248-0420  
Email:  
MRService@mccallaraymer.com  
2586358  
13-00936-5  
Mar. 28; Apr. 4, 2014 14-01892P

## SECOND INSERTION

NOTICE OF RESCHEDULED SALE  
IN THE CIRCUIT COURT OF THE  
SIXTH JUDICIAL CIRCUIT IN AND  
FOR PASCO COUNTY, FLORIDA  
CIVIL ACTION

**CASE NO. 51-2012-CA-005677-CAAX-WS**  
**US BANK NATIONAL ASSOCIATION, AS TRUSTEE FOR SASCO MORTGAGE LOAN TRUST 2005-WF4, Plaintiff, vs. SHANNON MARIE SIMON, et al, Defendant(s).**

NOTICE IS HEREBY GIVEN Pursuant to an Order Rescheduling Foreclosure Sale dated on or about March 12, 2014, and entered in Case No. 51-2012-CA-005677-CAAX-WS of the Circuit Court of the Sixth Judicial Circuit in and for Pasco County, Florida in which US Bank National Association, as Trustee for SASCO Mortgage Loan Trust 2005-WF4, is the Plaintiff and Shannon Marie Simon also known as Shannon M. Simon a/k/a Shannon Simon, Beneficial Florida Inc., a Corporation, Jacob D. Simon also known as Jacob David Simon, Tenant # 1, Tenant # 2, The Unknown Spouse of Shannon Marie Simon also known as Shannon M. Simon a/k/a Shannon Simon also known as James Johnson, are defendants, the Pasco County Clerk of the Circuit Court will sell to the highest and best bidder for cash in/on held online [www.pasco.realforeclose.com](http://www.pasco.realforeclose.com): in Pasco County, Florida, Pasco County, Florida at 11:00AM on the 15th day of April, 2014, the following described property as set forth in said Final Judgment of Foreclosure:

LOT 419 OF JASMINE LAKES, Unit: 4-C, ACCORDING TO THE PLAT THEREOF, AS RECORDED IN PLAT BOOK 9 PAGE 44 OF THE PUBLIC RECORDS OF PASCO COUNTY,

FLORIDA  
A/K/A 7513 VALENCIA AVE,  
PORT RICHEY, FL 34668-2949

Any person claiming an interest in the surplus from the sale, if any, other than the property owner as of the date of the Lis Pendens must file a claim within 60 days after the sale.

If you are a person with a disability who needs an accommodation in order to participate in this proceeding, you are entitled, at no cost to you, to the provision of certain assistance. Please contact:

Public Information Dept., Pasco County Government Center 7530 Little Rd. New Port Richey, FL 34654 Phone: 727.847.8110 (voice) in New Port Richey 352.521.4274, ext 8110 (voice) in Dade City Or 711 for the hearing impaired

Contact should be initiated at least seven days before the scheduled court appearance, or immediately upon receiving this notification if the time before the scheduled appearance is less than seven days.

The court does not provide transportation and cannot accommodate such requests. Persons with disabilities needing transportation to court should contact their local public transportation providers for information regarding transportation services.

Dated in Hillsborough County, Florida on this 25th day of March, 2014.

/s/ Erik Del'Etoile  
Erik Del'Etoile, Esq.  
FL Bar # 71675

Albertelli Law  
Attorney for Plaintiff  
P.O. Box 23028  
Tampa, FL 33623  
(813) 221-4743  
(813) 221-9171 facsimile  
eService:  
servealaw@albertellilaw.com  
BM - 002745F01  
Mar. 28; Apr. 4, 2014 14-01893P

## SECOND INSERTION

NOTICE OF FORECLOSURE SALE IN THE CIRCUIT COURT OF THE 6TH JUDICIAL CIRCUIT, IN AND FOR PASCO COUNTY, FLORIDA CIVIL DIVISION:

**CASE NO.:**  
**51-2008-CA-008916ES**  
**DEUTSCHE BANK NATIONAL TRUST COMPANY, AS TRUSTEE FOR FFMLT TRUST 2006-FF13, MORTGAGE PASS-THROUGH CERTIFICATES SERIES 2006-FF13,**

**Plaintiff, vs.**  
**BRIAN L. GAIEFSKY A/K/A BRIAN LEE GAIEFSKY A/K/A BRIAN GAIEFSKY A/K/A B. GAIEFSKY; MORTGAGE ELECTRONIC REGISTRATION SYSTEMS INCORPORATED AS NOMINEE FOR FIRST FRANKLIN A DIVISION OF NAT. CITY BANK OF IN; SHARI S. GAIEFSKY A/K/A SHARI SUE GAIEFSKY A/K/A SHARI ROSENZWEIG A/K/A SHARI ROSENZWEIG-GAIEFSKY; UNKNOWN TENANT(S) IN POSSESSION OF THE SUBJECT PROPERTY,**

**Defendants.**  
NOTICE IS HEREBY GIVEN pursuant to Final Judgment of Foreclosure dated the 4th day of March, 2014, and entered in Case No. 51-2008-CA-008916ES, of the Circuit Court of the 6TH Judicial Circuit in and for Pasco County, Florida, wherein DEUTSCHE BANK NATIONAL TRUST COMPANY, AS TRUSTEE FOR FFMLT TRUST 2006-FF13,

MORTGAGE PASS-THROUGH CERTIFICATES SERIES 2006-FF13 is the Plaintiff and BRIAN L. GAIEFSKY A/K/A BRIAN LEE GAIEFSKY A/K/A BRIAN GAIEFSKY A/K/A B. GAIEFSKY; MORTGAGE ELECTRONIC REGISTRATION SYSTEMS INCORPORATED AS NOMINEE FOR FIRST FRANKLIN A DIVISION OF NAT. CITY BANK OF IN; SHARI S. GAIEFSKY A/K/A SHARI SUE GAIEFSKY A/K/A SHARI ROSENZWEIG A/K/A SHARI ROSENZWEIG-GAIEFSKY; UNKNOWN TENANT(S) IN POSSESSION OF THE SUBJECT PROPERTY are defendants. The Clerk of this Court shall sell to the highest and best bidder for cash, on the 23rd day of April, 2014, at 11:00 AM on Pasco County's Public Auction website: www.pasco.realforeclose.com, pursuant to judgment or order of the Court, in accordance with Chapter 45, Florida Statutes, the following described property as set forth in said Final Judgment, to wit:

LOT 105, COUNTRY WALK INCREMENT-F PHASE 1, ACCORDING TO SUBDIVISION PLAT RECORDED IN PLAT BOOK 55, PAGE 1-11 OF THE PUBLIC RECORDS OF PASCO COUNTY, FLORIDA.

ANY PERSON CLAIMING AN INTEREST IN THE SURPLUS FROM THE SALE, IF ANY, OTHER THAN THE PROPERTY OWNER AS OF THE DATE OF THE LIS PENDENS MUST FILE A CLAIM WITHIN 60

DAYS AFTER THE SALE.

If you are a person with a disability who needs any accommodation in order to participate in this proceeding, you are entitled, at no cost to you, to the provision of certain assistance. Please contact the Public Information Dept., Pasco County Government Center, 7530 Little Rd., New Port Richey, FL 34654; (727) 847-8110 (V) in New Port Richey; (352) 521-4274, ext 8110 (V) in Dade City, at least 7 days before your scheduled court appearance, or immediately upon receiving this notification if the time before the scheduled appearance is less than 7 days; if you are hearing impaired call 711. The court does not provide transportation and cannot accommodate for this service. Persons with disabilities needing transportation to court should contact their local public transportation providers for information regarding transportation services.

Dated this 25 day of March, 2014.

By: Jennifer Nicole Tarquinio  
Bar #99192

Submitted by:  
Choice Legal Group, P.A.  
P.O. Box 9908  
Fort Lauderdale, FL 33310-9908  
Telephone: (954) 453-0365  
Facsimile: (954) 771-6052  
Toll Free: 1-800-441-2438  
DESIGNATED PRIMARY E-MAIL FOR SERVICE PURSUANT TO FLA. R. JUD. ADMIN 2.516  
eservice@cleagalgroup.com  
08-53569  
Mar. 28; Apr. 4, 2014 14-01912P

NOTICE OF FORECLOSURE SALE IN THE CIRCUIT COURT OF THE SIXTH JUDICIAL CIRCUIT IN AND FOR PASCO COUNTY, FLORIDA GENERAL JURISDICTION DIVISION

**CASE NO. 51-2009-CA-006037WS**  
**HSBC BANK USA, NATIONAL ASSOCIATION, AS TRUSTEE UNDER THE POOLING AND SERVICING AGREEMENT DATED AS OF MAY 1, 2006 FREMONT HOME LOAN TRUST 2006-A,**  
**Plaintiff, vs.**  
**EDWARD S. CLEAVER and DIANNA LYNN BALZER A/K/A DIANNA LYNN CLEAVER, et al.**  
**Defendant(s).**

NOTICE IS HEREBY GIVEN pursuant to a Final Judgment of Foreclosure dated February 26, 2014, and entered in 51-2009-CA-006037WS of the Circuit Court of the Sixth Judicial Circuit in and for Pasco County, Florida, wherein HSBC BANK USA, NATIONAL ASSOCIATION, AS TRUSTEE UNDER THE POOLING AND SERVICING AGREEMENT DATED AS OF MAY 1, 2006 FREMONT HOME LOAN TRUST 2006-A, is the Plaintiff and EDWARD S. CLEAVER; DIANNA LYNN BALZER A/K/A DIANNA LYNN CLEAVER; JASMINE LAKES COMMUNITY AND CIVIC ASSOCIATION, INC.; UNKNOWN TENANTS; PHONG KNA NGUYEN are the Defendant(s). Paula O'Neil as the Clerk of the Circuit Court will sell to the highest and best bidder for cash, www.pasco.realforeclose.com, at 11:00 AM on April 17, 2014, the following described property as set forth in said

## SECOND INSERTION

Final Judgment, to wit:

LOT 1229 OF THE UNRECORDED PLAT OF JASMINE LAKES, UNIT SEVEN; A PORTION OF THE SOUTHEAST 1/4 OF SECTION 15, TOWNSHIP 25 SOUTH, RANGE 16 EAST, PASCO COUNTY, FLORIDA, BEING FURTHER DESCRIBED AS FOLLOWS: COMMENCE AT THE SOUTHWEST CORNER OF THE SOUTHEAST 1/4 OF SAID SECTION 15; THENCE RUN ALONG THE WEST LINE OF THE SOUTHEAST 1/4 OF SAID SECTION 15, NORTH 00 DEGREES 15'00" EAST, A DISTANCE OF 518.89 FEET; THENCE SOUTH 89 DEGREES 43'05" EAST, A DISTANCE OF 1694.83 FEET FOR A POINT OF BEGINNING; THENCE NORTH 0 DEGREES 16'55" EAST, A DISTANCE OF 100 FEET; THENCE SOUTH 89 DEGREES 43'05" EAST, A DISTANCE OF 70 FEET; THENCE SOUTH 00 DEGREES 16'55" WEST, A DISTANCE OF 100 FEET; THENCE NORTH 89 DEGREES 43'05" WEST, A DISTANCE OF 70 FEET TO THE POINT OF BEGINNING; THE SOUTH 10 FEET AND THE EAST 3 FEET THEREOF BEING SUBJECT TO AN EASEMENT OF DRAINAGE AND/OR UTILITIES. THIS BEING DESCRIPTION OF LOT 1229, UNIT 7-A, JASMINE LAKES SUBDIVISION, PLAT BOOK 11, PAGES 122 AND 123, OF THE PUBLIC RECORDS OF PASCO COUNTY,

FLORIDA, THE SAID LOT 1229 BEING NOTED AS NOT BEING A PART OF THIS PLAT.

Any person claiming an interest in the surplus from the sale, if any, other than the property owner as of the date of the lis pendens must file a claim within 60 days after the sale.

IMPORTANT

If you are a person with a disability who needs any accommodation in order to participate in this proceeding, you are entitled, at no cost to you, to the provision of certain assistance. Please contact the Public Information Dept., Pasco County Government Center, 7530 Little Rd., New Port Richey, FL 34654; (727) 847-8110 (V) in New Port Richey; (352) 521-4274, ext 8110 (V) in Dade City, at least 7 days before your scheduled court appearance, or immediately upon receiving this notification if the time before the scheduled appearance is less than 7 days; if you are hearing impaired call 711.

The court does not provide transportation and cannot accommodate for this service. Persons with disabilities needing transportation to court should contact their local public transportation providers for information regarding transportation services.

Dated this 24th day of March, 2014.

By: Liana R. Hall  
FL Bar No. 73813  
for Philip Jones  
Florida Bar: 107721

Robertson, Anschutz & Schneid, PL  
Attorneys for Plaintiff  
6409 Congress Avenue, Suite 100  
Boca Raton, Florida 33487  
13-13593  
Mar. 28; Apr. 4, 2014 14-01882P

## SECOND INSERTION

NOTICE OF SALE IN THE CIRCUIT COURT OF THE SIXTH JUDICIAL CIRCUIT OF THE STATE OF FLORIDA, IN AND FOR PASCO COUNTY CIVIL DIVISION

**CASE NO.**  
**51-2012-CA-007378-CAAX-WS**  
**GROW FINANCIAL FEDERAL CREDIT UNION,**  
**Plaintiff, vs.**

**MOLLY MAYO; UNKNOWN SPOUSE OF MOLLY MAYO; ERNEST J. MAYO; UNKNOWN SPOUSE OF ERNEST J. MAYO; IF LIVING, INCLUDING ANY UNKNOWN SPOUSE OF SAID DEFENDANT(S), IF REMARRIED, AND IF DECEASED, THE RESPECTIVE UNKNOWN HEIRS, DEVISEES, GRANTEEES, ASSIGNEES, CREDITORS, LIENORS, AND TRUSTEES, AND ALL OTHER PERSONS CLAIMING BY, THROUGH, UNDER OR AGAINST THE NAMED DEFENDANT(S); UNKNOWN TENANT #1; UNKNOWN TENANT #2;**  
**Defendant(s)**

Notice is hereby given that, pursuant to a Final Summary Judgment of Foreclosure entered on 02/19/2014 in the above-styled cause, in the Circuit Court of Pasco County, Florida, the office of Paula S. O'Neil clerk of the circuit court will sell the property situate in Pasco County, Florida, described as:

PUBLIC RECORDS OF PASCO COUNTY, FLORIDA.

at public sale, to the highest and best bidder, for cash, www.pasco.realforeclose.com at 11:00 o'clock, A.M, on April 17, 2014

Any person claiming an interest in the surplus from the sale, if any, other than the property owner as of the date of the lis pendens, must file a claim within 60 days after the sale.

If you are a person with a disability who needs any accommodation in order to participate in this proceeding, you are entitled, at no cost to you, to the provision of certain assistance. Please contact the Public Information Dept., Pasco County Government Center, 7530 Little Rd., New Port Richey, FL 34654; (727) 847-8110 (V) for proceedings in New Port Richey; (352) 521-4274, ext. 8110 (V) for proceedings in Dade City, at least 7 days before your scheduled court appearance, or immediately upon receiving this notification if the time before the scheduled appearance is less than 7 days; if you are hearing impaired call 711.

Date: 03/25/2014

ATTORNEY FOR PLAINTIFF  
By /s/ Josh D. Donnelly  
Josh D. Donnelly  
Florida Bar #64788

THIS INSTRUMENT PREPARED BY:  
Law Offices of Daniel C. Consuegra  
9204 King Palm Drive  
Tampa, FL 33619-1328  
Phone: 813-915-8660  
Attorneys for Plaintiff  
135357  
Mar. 28; Apr. 4, 2014 14-01902P

## SECOND INSERTION

NOTICE OF FORECLOSURE SALE IN THE CIRCUIT COURT OF THE SIXTH JUDICIAL CIRCUIT, IN AND FOR PASCO COUNTY, FLORIDA

**Case No.**  
**51-2009-CA-010350-XXXX-ES**  
**THE BANK OF NEW YORK MELLON FKA THE BANK OF NEW YORK, AS TRUSTEE FOR THE CERTIFICATEHOLDERS OF THE CWABS, INC., ASSET-BACKED CERTIFICATES, SERIES 2007-9,**  
**PLAINTIFF, VS.**  
**GABRIEL ROMERO, ET AL., DEFENDANT(S).**

NOTICE IS HEREBY GIVEN pursuant to an Order of Final Summary Judgment of Foreclosure dated the 26th day of February, 2014, and entered in Case No. 51-2009-CA-010350-XXXX-ES, of the Circuit Court of the Sixth Judicial Circuit in and for Pasco County, Florida. I will sell to the highest and best bidder for cash at the Pasco County's Public Auction website, www.pasco.realforeclose.com, at 11:00 A.M. on the 14th day of April, 2014 the following described property as set forth in said Final Judgment, to wit:

LOT 13, BLOCK E, NORTHWOOD UNIT 6A, ACCORDING TO THE MAP OR PLAT THEREOF AS RECORDED IN PLAT BOOK 41, PAGE(S) 32 AND 33, PUBLIC RECORDS OF PASCO COUNTY, FLORIDA

Property Address: 1514 Ocean Reef Road, Wesley Chapel, FL 33543-6694

Any person claiming an interest in the surplus from the sale, if any, other than the property owner as of the date of the

Lis Pendens, must file a claim within 60 days after the sale.

If you are a person with a disability who needs an accommodation in order to participate in this proceeding, you are entitled, at no cost to you, to the provision of certain assistance. Please contact: Public Information Dept., Pasco County Government Center, 7530 Little Rd., New Port Richey, FL 34654; Phone: 727.847.8110 (voice) in New Port Richey, 352.521.4274, ext 8110 (voice) in Dade City, Or 711 for the hearing impaired. Contact should be initiated at least seven days before the scheduled court appearance, or immediately upon receiving this notification if the time before the scheduled appearance is less than seven days. The court does not provide transportation and cannot accommodate such requests. Persons with disabilities needing transportation to court should contact their local public transportation providers for information regarding transportation services.

Walter H. Porr, Jr., Esq.  
Florida Bar#: 107388

Connolly, Geaney, Ablitt & Willard, PC  
The Blackstone Building  
100 South Dixie Highway, Suite 200  
West Palm Beach, FL 33401  
Primary E-mail:  
pleadings@acdlaw.com  
Secondary E-mail:  
wporr@acdlaw.com  
Toll Free: (561) 422-4668  
Facsimile: (561) 249-0721  
Counsel for Plaintiff  
File#: C209.20036  
Mar. 28; Apr. 4, 2014 14-01851P

## SECOND INSERTION

NOTICE OF SALE PURSUANT TO CHAPTER 45 IN THE CIRCUIT COURT OF THE SIXTH JUDICIAL CIRCUIT IN AND FOR PASCO COUNTY, FLORIDA CIVIL ACTION

**CASE NO.:**  
**51-2013-CA-000690-CAAX-WS**  
**BANK OF AMERICA, N.A., Plaintiff, vs.**  
**PETROPOULOS, CHRISTE E. et al, Defendant(s).**

NOTICE IS HEREBY GIVEN Pursuant to a Final Judgment of Foreclosure dated February 26, 2014, and entered in Case No. 51-2013-CA-000690-CAAX-WS of the Circuit Court of the Sixth Judicial Circuit in and for Pasco County, Florida in which Bank of America, N.A., is the Plaintiff and Bank of America, N.A., Christe E. Petropoulos also known as Chris E. Petropoulos, also known as Chris Petropoulos, Tenant # 1, are defendants, the Pasco County Clerk of the Circuit Court will sell to the highest and best bidder for cash in/on held online www.pasco.realforeclose.com: in Pasco County, Florida, Pasco County, Florida at 11:00AM on the 17th day of April, 2014, the following described property as set forth in said Final Judgment of Foreclosure:

LOT 208, TAHITIAN HOMES, UNIT FOUR, ACCORDING TO THE PLAT THEREOF AS RECORDED IN PLAT BOOK 9, PAGE(S) 46, OF THE PUBLIC RECORDS OF PASCO COUNTY, FLORIDA.

3910 CEDARWOOD DR, HOLLDAY, FL 34691-3420

Any person claiming an interest in the surplus from the sale, if any, other than the property owner as of the date of the

Lis Pendens must file a claim within 60 days after the sale.

If you are a person with a disability who needs an accommodation in order to participate in this proceeding, you are entitled, at no cost to you, to the provision of certain assistance. Please contact:

Public Information Dept., Pasco County Government Center 7530 Little Rd. New Port Richey, FL 34654 Phone: 727.847.8110 (voice) in New Port Richey 352.521.4274, ext 8110 (voice) in Dade City Or 711 for the hearing impaired

Contact should be initiated at least seven days before the scheduled court appearance, or immediately upon receiving this notification if the time before the scheduled appearance is less than seven days.

The court does not provide transportation and cannot accommodate such requests. Persons with disabilities needing transportation to court should contact their local public transportation providers for information regarding transportation services.

Dated in Hillsborough County, Florida, this 25th day of March, 2014

/s/ Erik Del'Etoile  
Erik Del'Etoile, Esq.  
FL Bar # 71675

Albertelli Law  
Attorney for Plaintiff  
P.O. Box 23028  
Tampa, FL 33623  
(813) 221-4743  
(813) 221-9171 facsimile  
eService:  
servealaw@albertellilaw.com  
BM - 008533F01  
Mar. 28; Apr. 4, 2014 14-01915P

## SECOND INSERTION

NOTICE OF FORECLOSURE SALE IN THE CIRCUIT COURT OF THE SIXTH JUDICIAL CIRCUIT IN AND FOR PASCO COUNTY, FLORIDA GENERAL JURISDICTION DIVISION

**Case No.**  
**51-2012-CA-003037-WS J-3**  
**The Bank of New York Mellon fka The Bank of New York, as Trustee for the Certificateholders of the CWABS, Inc., Asset-Backed Certificates, Series 2006-15,**  
**Plaintiff, vs.**

**Patrick J. Tamse aka Patrick Tamse; et al., Defendants.**

NOTICE IS HEREBY GIVEN pursuant to a Final Judgment of Foreclosure dated February 27, 2014, entered in Case No. 51-2012-CA-003037-WS J-3 of the Circuit Court of the Sixth Judicial Circuit, in and for Pasco County, Florida, wherein The Bank of New York Mellon fka The Bank of New York, as Trustee for the Certificateholders of the CWABS, Inc., Asset-Backed Certificates, Series 2006-15 is the Plaintiff and Patrick J. Tamse aka Patrick Tamse; Unknown Spouse of Patrick J. Tamse aka Patrick Tamse; Christina Marie Tamse; Clerk of the Court, Pasco County, Florida; Unknown Tenant #1; Unknown Tenant #2 are the Defendants, that the Clerk of Courts will sell to the highest and best bidder for cash by electronic sale at www.pasco.realforeclose.com, beginning at 11:00 AM on the 22nd day of April, 2014, the following described property as set forth in said Final Judgment,

to wit:

LOT 46, ORANGWOOD VILLAGE, ACCORDING TO THE MAP OR PLAT THEREOF AS RECORDED IN PLAT BOOK 7, PAGE 116, OF THE PUBLIC RECORDS OF PASCO COUNTY, FLORIDA.

If you are a person with a disability who needs any accommodation in order to participate in this proceeding, you are entitled, at no cost to you, to the provision of certain assistance. Please contact the Public Information Dept., Pasco County Government Center, 7530 Little Rd., New Port Richey, FL 34654; (727) 847-8110 (V) in New Port Richey; (352) 521-4274, ext 8110 (V) in Dade City, at least 7 days before your scheduled court appearance, or immediately upon receiving this notification if the time before the scheduled appearance is less than 7 days; if you are hearing impaired call 711. The court does not provide transportation and cannot accommodate for this service. Persons with disabilities needing transportation to court should contact their local public transportation providers for information regarding transportation services.

Dated this 25th day of March, 2014.

By Jimmy Edwards, Esq.  
Florida Bar No. 81855

BROCK & SCOTT, PLLC  
Attorney for Plaintiff  
1501 N.W. 49th Street,  
Suite 200  
Ft. Lauderdale, FL 33309  
Phone: (954) 618-6955, ext. 6209  
Fax: (954) 618-6954  
FLCourtDocs@brockandscott.com  
11-F04287  
Mar. 28; Apr. 4, 2014 14-01896P

## SECOND INSERTION

NOTICE OF SALE IN THE CIRCUIT COURT OF THE SIXTH JUDICIAL CIRCUIT OF THE STATE OF FLORIDA, IN AND FOR PASCO COUNTY CIVIL DIVISION

**Case No.**  
**51-2011-CA-002916-CAAX-WS**  
**FEDERAL NATIONAL MORTGAGE ASSOCIATION, Plaintiff, vs.**  
**JOSE A. PE; UNKNOWN SPOUSE OF JOSE A. PE; GARRY J. NORRIS; UNKNOWN SPOUSE OF GARRY J. NORRIS; IF LIVING, INCLUDING ANY UNKNOWN SPOUSE OF SAID DEFENDANT(S), IF REMARRIED, AND IF DECEASED, THE RESPECTIVE UNKNOWN HEIRS, DEVISEES, GRANTEEES, ASSIGNEES, CREDITORS, LIENORS, AND TRUSTEES, AND ALL OTHER PERSONS CLAIMING BY, THROUGH, UNDER OR AGAINST THE NAMED DEFENDANT(S); UNKNOWN TENANT #1; UNKNOWN TENANT #2; UNKNOWN TENANT #3; UNKNOWN TENANT #4; UNKNOWN TENANT #5; UNKNOWN TENANT #6; UNKNOWN TENANT #7; UNKNOWN TENANT #8;**  
**Defendant(s)**

Notice is hereby given that, pursuant to a Final Summary Judgment of Foreclosure entered on 02/19/2014 in the above-styled cause, in the Circuit Court of Pasco County, Florida, the office of Paula S. O'Neil clerk of the circuit court will sell the property situate in Pasco County, Florida, described as:

LOTS 15 AND 16, SIESTA TERRACE, ACCORDING TO

THE PLAT THEREOF, AS RECORDED IN PLAT BOOK 6, PAGE 11, OF THE PUBLIC RECORDS BOOK OF PASCO COUNTY, FLORIDA.

at public sale, to the highest and best bidder, for cash, www.pasco.realforeclose.com at 11:00 o'clock, A.M, on April 17, 2014

Any person claiming an interest in the surplus from the sale, if any, other than the property owner as of the date of the lis pendens, must file a claim within 60 days after the sale.

If you are a person with a disability who needs any accommodation in order to participate in this proceeding, you are entitled, at no cost to you, to the provision of certain assistance. Please contact the Public Information Dept., Pasco County Government Center, 7530 Little Rd., New Port Richey, FL 34654; (727) 847-8110 (V) for proceedings in New Port Richey; (352) 521-4274, ext. 8110 (V) for proceedings in Dade City, at least 7 days before your scheduled court appearance, or immediately upon receiving this notification if the time before the scheduled appearance is less than 7 days; if you are hearing impaired call 711.

Date: 03/25/2014

ATTORNEY FOR PLAINTIFF  
By /s/ Josh D. Donnelly  
Josh D. Donnelly  
Florida Bar #64788

THIS INSTRUMENT PREPARED BY:  
Law Offices of Daniel C. Consuegra  
9204 King Palm Drive  
Tampa, FL 33619-1328  
Phone: 813-915-8660  
Attorneys for Plaintiff  
94434  
Mar. 28; Apr. 4, 2014 14-01904P

## SECOND INSERTION

NOTICE OF FORECLOSURE SALE PURSUANT TO CHAPTER 45 IN THE CIRCUIT COURT OF THE SIXTH JUDICIAL CIRCUIT IN AND FOR PASCO COUNTY, FLORIDA

**CASE NO.**  
**51-2009-CA-001390-XXXX-WS**  
**DEUTSCHE BANK TRUST COMPANY AMERICAS AS TRUSTEE,**  
**Plaintiff(s), vs.**  
**LINDA P. THOMAS; et al., Defendant(s).**

NOTICE IS HEREBY GIVEN that Sale will be made pursuant to an Order or Final Summary Judgment. Final Judgment was awarded on February 17, 2014 in Civil Case No.: 51-2009-CA-001390-XXXX-WS, of the Circuit Court of the SIXTH Judicial Circuit in and for Pasco County, Florida, wherein, DEUTSCHE BANK TRUST COMPANY AMERICAS AS TRUSTEE is the Plaintiff, and, LINDA P. THOMAS; KEVIN A. THOMAS; AND UNKNOWN TENANT(S) IN POSSESSION are Defendants.

The clerk of the court, Paula S. O'Neil, Ph.D., will sell to the highest bidder for cash online at www.pasco.realforeclose.com at 11:00 AM on April 10, 2014, the following described real property as set forth in said Final summary Judgment, to wit:

LOT 234, SAN CLEMENTE EAST, UNIT TWO, ACCORDING TO THE MAP OR PLAT THEREOF AS RECORDED IN PLAT BOOK 10, PAGE 75, OF THE PUBLIC RECORDS OF PASCO COUNTY, FLORIDA. PROPERTY ADDRESS: 9805 EL CAMINO REAL, PORT RICHEY, FLORIDA 346688

ANY PERSON CLAIMING AN INTEREST IN THE SURPLUS FROM

THE SALE, IF ANY, OTHER THAN THE PROPERTY OWNER AS OF THE DATE OF THE LIS PENDENS MUST FILE A CLAIM WITHIN 60 DAYS AFTER THE SALE.

IMPORTANT

If you are a person with a disability who needs an accommodation in order to participate in this proceeding, you are entitled, at no cost to you, to the provision of certain assistance. Please contact: Public Information Dept., Pasco County Government Center, 7530 Little Rd., New Port Richey, FL 34654; Phone: 727.847.8110 (voice) in New Port Richey, 352.521.4274, ext 8110 (voice) in Dade City, Or 711 for the hearing impaired. Contact should be initiated at least seven days before the scheduled court appearance, or immediately upon receiving this notification if the time before the scheduled appearance is less than seven days. The court does not provide transportation and cannot accommodate such requests. Persons with disabilities needing transportation to court should contact their local public transportation providers for information regarding transportation services.

Dated this 25 day of March, 2014.

BY: Nalini Singh  
FBN: 43700  
Primary E-Mail:  
ServiceMail@aclawllp.com  
Secondary E-Mail:  
NSingh@aclawllp.com

Aldridge | Connors, LLP  
Attorney for Plaintiff(s)  
1615 South Congress Avenue  
Suite 200  
Delray Beach, FL 33445  
Phone: 561.392.6391  
Fax: 561.392.6965  
1271-558B  
Mar. 28; Apr. 4, 2014 14-01909P

SECOND INSERTION

NOTICE OF FORECLOSURE SALE IN THE CIRCUIT COURT OF THE 6TH JUDICIAL CIRCUIT, IN AND FOR PASCO COUNTY, FLORIDA CIVIL DIVISION  
**CASE NO. 51-2013-CA-002956-CAAX-WS**  
**JPMORGAN CHASE BANK, NATIONAL ASSOCIATION**  
**Plaintiff, vs.**  
**RUDY LOPEZ; DAWN LOPEZ; et al;**  
**Defendants.**  
NOTICE IS HEREBY GIVEN pursuant to a Final Judgment of Foreclosure dated 12th day of March, 2014, and entered in Case No. 51-2013-CA-002956-CAAX-WS, of the Circuit Court of the 6th Judicial Circuit in and for PASCO County, Florida, wherein JPMORGAN CHASE BANK, NATIONAL ASSOCIATION is Plaintiff and RUDY LOPEZ; DAWN LOPEZ; UNKNOWN PERSON(S) IN POSSESSION OF THE SUBJECT PROPERTY; are defendants. The Clerk of Court will sell

to the highest and best bidder for cash BY ELECTRONIC SALE AT: WWW.PASCO.REALFORECLOSE.COM, at 11:00 A.M., on the 24th day of April, 2014, the following described property as set forth in said Final Judgment, to wit:  
LOT 293, LA VILLA GARDENS UNIT TWO, ACCORDING TO MAP OR PLAT THEREOF AS RECORDED IN PLAT BOOK 12, PAGES 78 AND 79, OF THE PUBLIC RECORDS OF PASCO COUNTY, FLORIDA.  
A person claiming an interest in the surplus from the sale, if any, other than the property owner as of the date of the lis pendens must file a claim within 60 days after the sale.  
This notice is provided pursuant to Administrative Order 2010-045 PA/PI-CIR "If you are a person with disability who needs any accommodation in order to participate in this proceeding, you are entitled, at no cost to you the provision of certain assistance.

Please contact Public Information Dept., Pasco County Government Center, 7530 Little Rd., New Port Richey, FL 34654; (727) 847-8110 (V) for proceedings in New Port Richey; (352) 521-4274, ext. 8110 (V) for proceedings in Dade City at least 7 days before your scheduled court appearance, or immediately upon receiving this notification if the time before the scheduled appearance is less than 7 days; if you are hearing or voice impaired, call 711."  
Dated this 26th day of March, 2014.  
By: Eric M. Knopp, Esq.  
Bar No.: 709921  
Submitted by:  
Kahane & Associates, P.A.  
8201 Peters Road, Ste.3000  
Plantation, FL 33324  
Telephone: (954) 382-3486  
Telefacsimile: (954) 382-5380  
Designated service email:  
notice@kahaneandassociates.com  
File No.: 13-02328 JPC  
Mar. 28; Apr. 4, 2014 14-01920P

SECOND INSERTION

NOTICE OF RESCHEDULED SALE IN THE CIRCUIT COURT OF THE SIXTH JUDICIAL CIRCUIT IN AND FOR PASCO COUNTY, FLORIDA CIVIL ACTION  
**CASE NO.: 51-2009-CA-011233-CAAX-ES**  
**WACHOVIA MORTGAGE, F.S.B. F/K/A WORLD SAVINGS BANK, F.S.B.,**  
**Plaintiff, vs.**  
**JOANN CRAFT, et al,**  
**Defendant(s).**  
NOTICE IS HEREBY GIVEN Pursuant to an Order Rescheduling Foreclosure Sale dated on or about February 19, 2014, and entered in Case No. 51-2009-CA-011233-CAAX-ES of the Circuit Court of the Sixth Judicial Circuit in and for Pasco County, Florida in which Wachovia Mortgage, F.S.B. f/k/a World Savings Bank, F.S.B., is the Plaintiff and Joann Craft, Chase Bank USA, N.A., Vermillion Homeowners Association, Inc. are defendants, the Pasco County Clerk of the Circuit Court will sell to the highest and best bidder for cash held online www.pasco.realforeclose.com in Pasco County, Florida, Pasco County, Florida at 11:00AM on the 9th day of April 2014, the following described property as set forth in said Final Judgment of Foreclosure:  
LOT 5, BLOCK 44, OF MEADOW POINTE PARCEL 16, UNIT 2A, ACCORDING TO THE MAP OR PLAT THEREOF, AS RECORDED IN PLAT BOOK 39, PAGES 57 THROUGH 63, OF THE PUBLIC RECORDS OF PASCO COUNTY, FLORIDA. A/K/A 1232 THROCKMORTON DRIVE, WESLEY CHAPEL, FL 33543

Any person claiming an interest in the surplus from the sale, if any, other than the property owner as of the date of the Lis Pendens must file a claim within 60 days after the sale.  
If you are a person with a disability who needs an accommodation in order to participate in this proceeding, you are entitled, at no cost to you, to the provision of certain assistance. Please contact:  
Public Information Dept., Pasco County Government Center 7530 Little Rd. New Port Richey, FL 34654 Phone: 727.847.8110 (voice) in New Port Richey 352.521.4274, ext 8110 (voice) in Dade City Or 711 for the hearing impaired  
Contact should be initiated at least seven days before the scheduled court appearance, or immediately upon receiving this notification if the time before the scheduled appearance is less than seven days.  
The court does not provide transportation and cannot accommodate such requests. Persons with disabilities needing transportation to court should contact their local public transportation providers for information regarding transportation services.  
Dated in Hillsborough County, Florida this 25th day of March, 2014.  
/s/ Erik Del'Etoile  
Erik Del'Etoile, Esq.  
FL Bar # 71675  
Albertelli Law  
Attorney for Plaintiff  
P.O. Box 23028  
Tampa, FL 33623  
(813) 221-4743  
JR-09-28430  
Mar. 28; Apr. 4, 2014 14-01925P

SECOND INSERTION

NOTICE OF FORECLOSURE SALE IN THE CIRCUIT COURT OF THE SIXTH JUDICIAL CIRCUIT IN AND FOR PASCO COUNTY, FLORIDA CIVIL ACTION  
**CASE NO.: 51-2012-CA-002494WS**  
**DIVISION: J2**  
**WELLS FARGO BANK, NA,**  
**Plaintiff, vs.**  
**CATHY SIEGEL AKA CATHY NEUSES AKA CATHY LYNN NEUSES, et al,**  
**Defendant(s).**  
NOTICE IS HEREBY GIVEN pursuant to a Final Judgment of Mortgage Foreclosure dated March 21, 2014 and entered in Case No. 51-2012-CA-002494WS of the Circuit Court of the SIXTH Judicial Circuit in and for PASCO County, Florida wherein WELLS FARGO BANK, NA is the Plaintiff and CATHY SIEGEL AKA CATHY NEUSES AKA CATHY LYNN NEUSES; THE UNKNOWN SPOUSE OF CATHY SIEGEL AKA CATHY NEUSES AKA CATHY LYNN NEUSES N/K/A ROBERT SIEGEL; SUNTRUST BANK; are the Defendants, The Clerk will sell to the highest and best bidder for cash at WWW.PASCO.REALFORECLOSE.COM IN ACCORDANCE WITH CHAPTER 45 FLORIDA STATUTES at 11:00AM, on 05/06/2014, the following described property as set forth in said Final Judgment:  
LOT 2084, HOLIDAY LAKE ESTATES UNIT 21, ACCORDING TO THE MAP OR PLAT THEREOF AS RECORDED IN

NOTICE OF RESCHEDULED FORECLOSURE SALE IN THE CIRCUIT COURT OF THE SIXTH JUDICIAL CIRCUIT IN AND FOR PASCO COUNTY, FLORIDA CIVIL ACTION  
**CASE NO.: 51-2010-CA-004237-ES**  
**DIVISION: J1**  
**WELLS FARGO BANK, NA,**  
**Plaintiff, vs.**  
**RAFAEL PEREZ, et al,**  
**Defendant(s).**  
NOTICE IS HEREBY GIVEN pursuant to an Order Rescheduling Foreclosure Sale dated March 21, 2014 and entered in Case No. 51-2010-CA-004237-ES of the Circuit Court of the SIXTH Judicial Circuit in and for PASCO County, Florida wherein WELLS FARGO BANK, NA, is the Plaintiff and RAFAEL PEREZ; CARYN JANELL PEREZ; WELLS FARGO FINANCIAL BANK; are the Defendants, The Clerk will sell to the highest and best bidder for cash at WWW.

SECOND INSERTION

PASCO.REALFORECLOSE.COM IN ACCORDANCE WITH CHAPTER 45 FLORIDA STATUTES at 11:00AM, on 04/23/2014, the following described property as set forth in said Final Judgment:  
LOT 9, BLOCK 22, FOX RIDGE UNIT FOUR PHASE TWO, ACCORDING TO THE MAP OR PLAT THEREOF, AS RECORDED IN PLAT BOOK 19, PAGES 113 THROUGH 115, PUBLIC RECORDS OF PASCO COUNTY, FLORIDA  
A/K/A 31408 CROSS CREEK LANE, ZEPHYRHILLS, FL 33543  
Any person claiming an interest in the surplus from the sale, if any, other than the property owner as of the date of the Lis Pendens must file a claim within sixty (60) days after the sale.  
\*\*See Americans with Disabilities Act  
\*If you are a person with a disability who needs an accommodation in order

to participate in this proceeding, you are entitled, at no cost to you, to the provision of certain assistance. Please contact:  
Public Information Dept., Pasco County Government Center 7530 Little Rd. New Port Richey, FL 34654 Phone: 727.847.8110 (voice) in New Port Richey 352.521.4274, ext 8110 (voice) in Dade City Or 711 for the hearing impaired  
Contact should be initiated at least seven days before the scheduled court appearance, or immediately upon receiving this notification if the time before the scheduled appearance is less than seven days."  
By: Luke Kiel  
Florida Bar No. 98631  
Ronald R Wolfe & Associates, P.L.  
P.O. Box 25018  
Tampa, Florida 33622-5018  
(813) 251-4766  
(813) 251-1541 Fax  
F10034061  
Mar. 28; Apr. 4, 2014 14-01926P

FOURTH INSERTION

NOTICE OF ACTION IN THE COUNTY COURT IN AND FOR PASCO COUNTY, FLORIDA CIVIL DIVISION CASE NO.: 2014CC000540ES/T  
**EGRET LANDING AT TAMPA BAY ASSOCIATION, INC.,**  
**Plaintiff, vs.**  
**THE UNKNOWN HEIRS, DEVISEES, GRANTEES, ASSIGNEES, LIENORS, CREDITORS, TRUSTEES, OR OTHER CLAIMANTS CLAIMING BY THROUGH, UNDER OR AGAINST CHARLENE C. AMOS,**  
**Defendants.**  
TO: UNKNOWN HEIRS AND/OR BENEFICIARIES OF CHARLENE C. AMOS, DECEASED  
10731 COLLAR DRIVE  
SAN ANTONIO, FL 33576  
YOU ARE NOTIFIED that an action to foreclose a lien on the following property in Hillsborough

County, Florida:  
Lot 201, Tampa Bay Golf and Tennis Club, Phase IIIA, according to the map or plat thereof as recorded in Plat Book 38, pages 1 through 6, Public Records of Pasco County, Florida.  
A lawsuit has been filed against you and you are required to serve a copy of your written defenses, if any, on or before 30 days after the first publication of this Notice of Action, on Steven H. Mezer, Plaintiff's Attorney, whose address is P.O. Box 3913, Tampa, Florida 33601, and file the original with this Court either before service on Plaintiff's attorney or immediately thereafter; otherwise a default will be entered against you for the relief demanded in the Complaint or petition.  
This notice shall be published once each week for four consecutive weeks in the Business Observer.  
In accordance with the Americans with Disabilities Act, if you are a person

with a disability who needs any accommodation in order to participate in this proceeding, you are entitled, at no cost to you, to the provisions of certain assistance. Please contact the Public Information Department, Pasco County Government Center, 7530 Little Road, New Port Richey, FL 34654 or telephone (727) 847-8110 in New Port Richey or (352) 521-4274 ext. 8110 in Dade City within two (2) days of your receipt of this Notice; if you are hearing impaired, dial 711.  
WITNESS my hand and the seal of this Court on this 11 day of MAR, 2014.  
Paula S. O'Neil  
Clerk of Court  
By: /s/ Susannah Hennessy  
Steven H. Mezer, Esq.  
BUSH ROSS, P.A.  
P. O. Box 3913  
Tampa, FL 33601  
Telephone: (813) 204-6404  
Counsel for Plaintiff  
1574373.v1  
Mar. 14, 21, 28; April 4, 2014 14-01573P

FOURTH INSERTION

NOTICE OF ACTION IN THE COUNTY COURT IN AND FOR PASCO COUNTY, FLORIDA CIVIL DIVISION CASE NO.: 2013-CC-003183-ES/T  
**BALLANTRAE HOMEOWNERS ASSOCIATION, INC.,**  
**Plaintiff, vs.**  
**GUS RODRIGUEZ, A SINGLE MAN,**  
**Defendant.**  
TO: GUS RODRIGUEZ  
3036 GIANNA WAY  
LAND O' LAKES, FL 34638  
YOU ARE HEREBY NOTIFIED that an action for foreclosure of lien on the following described property:  
Lot 9, Block 8, BALLANTRAE VILLAGE 2A, according to the plat thereof as recorded in Plat Book 49, Pages 33 through 46, of the Public Records of Pasco County, Florida.  
Has been filed against you, and that you are required to serve a copy of your

written defenses, if any, to it on STEVEN H. MEZER, ESQUIRE, Plaintiff's attorney, whose address is Bush Ross P.A., Post Office Box 3913, Tampa, FL 33601, on or before 04/14/2014, a date within 30 days after the first publication of the notice and file the original with the Clerk of this Court either before service on Plaintiff's attorney or immediately thereafter; otherwise default will be entered against you for the relief demanded in the complaint or petition.  
If you are a person with a disability who needs any accommodation in order to participate in this proceeding, you are entitled, at no cost to you, to the provision of certain assistance. Please contact the Public Information Dept., Pasco County Government Center, 7530 Little Rd., New Port Richey, FL 34654; (727) 847-8110 (V) in New Port Richey; (352) 521-4274, ext 8110 (V) in Dade City, at least 7 days before your scheduled court appearance, or immediately

upon receiving this notification if the time before the scheduled appearance is less than 7 days; if you are hearing impaired call 711. The court does not provide transportation and cannot accommodate for this service. Persons with disabilities needing transportation to court should contact their local public transportation providers for information regarding transportation services.  
DATED on MAR 11, 2014.  
Paula S. O'Neil, Ph.D.,  
Clerk & Comptroller  
As Clerk of the Court  
By: /s/ Susannah Hennessy  
Deputy Clerk  
Steven H. Mezer, Esquire  
Florida Bar No. 239186  
Bush Ross PA  
P. O. Box 3913  
Tampa, Florida 33601  
(813) 204-6404  
Attorneys for Plaintiff  
1614467v1  
Mar. 14, 21, 28; April 4, 2014 14-01574P

THIRD INSERTION

NOTICE OF SUSPENSION  
TO: Jeremy R. Luteran  
Case No: 201304711  
A Notice of Suspension to suspend your license and eligibility for licensure has been filed against you. You have the right to request a hearing pursuant to Sections 120.569 and 120.57, Florida Statutes, by mailing a request for same to the Florida Department of Agriculture and Consumer Services, Division of Licensing, Post Office Box 3168, Tallahassee, Florida 32315-3168. If a request for hearing is not received by 21 days from the date of the last publication, the right to hearing in this matter will be waived and the Department will dispose of this cause in accordance with law.  
Mar. 21, 28, Apr. 4, 11, 2014 14-01778P

THIRD INSERTION

NOTICE OF ADMINISTRATIVE COMPLAINT  
TO: Michael S. Haney,  
Case No: 201104975  
An Administrative Complaint to revoke your license and eligibility for licensure has been filed against you. You have the right to request a hearing pursuant to Sections 120.569 and 120.57, Florida Statutes, by mailing a request for same to the Florida Department of Agriculture and Consumer Services, Division of Licensing, Post Office Box 3168, Tallahassee, Florida 32315-3168. If a request for hearing is not received by 21 days from the date of the last publication, the right to hearing in this matter will be waived and the Department will dispose of this cause in accordance with law.  
Mar. 21, 28, Apr. 4, 11, 2014 14-01779P

THIRD INSERTION

NOTICE OF ACTION IN THE CIRCUIT COURT OF THE SIXTH JUDICIAL CIRCUIT IN AND FOR PASCO COUNTY, FLORIDA CIVIL ACTION  
**CASE NO.: 51-2014-CA-00041IES**  
**DIVISION: Y**  
**JPMORGAN CHASE BANK, NATIONAL ASSOCIATION**  
**SUCCESSOR BY MERGER TO CHASE HOME FINANCE, LLC,**  
**Plaintiff, vs.**  
**TANYA HAWKINS A/K/A TANYA D HAMILTON A/K/A TANYA D HAMILTON, et al,**  
**Defendant(s).**  
TO:  
THE UNKNOWN HEIRS OF ROY HAWKINS A/K/A ROY K HAWKINS  
LAST KNOWN ADDRESS:  
UNKNOWN  
CURRENT ADDRESS:  
UNKNOWN  
ANY AND ALL UNKNOWN PARTIES CLAIMING BY, THROUGH, UNDER, AND AGAINST THE HEREIN NAMED INDIVIDUAL DEFENDANT(S) WHO ARE NOT KNOWN TO BE DEAD OR ALIVE, WHETHER SAID UNKNOWN PAR-

THIRD INSERTION

TIES MAY CLAIM AN INTEREST AS SPOUSES, HEIRS, DEVISEES, GRANTEES, OR OTHER CLAIMANTS  
LAST KNOWN ADDRESS:  
UNKNOWN  
CURRENT ADDRESS: UNKNOWN  
YOU ARE NOTIFIED that an action to foreclose a mortgage on the following property in PASCO County, Florida:  
LOT 144 OF THE UNRECORDED PLAT OF WILLIAMS ACRES UNIT TWO, DESCRIBED AS FOLLOWS: BEGIN AT THE SOUTHEAST CORNER OF THE SOUTH-EAST 1/4 OF THE SOUTH-WEST 1/4 OF SECTION 9, TOWNSHIP 26 SOUTH, RANGE 20 EAST, PASCO COUNTY, FLORIDA; THENCE SOUTH 89 DEGREES 41 MINUTES 14 SECONDS WEST, 330.00 FEET; THENCE NORTH 04 DEGREES 37 MINUTES 43 SECONDS WEST, 260.61 FEET; THENCE NORTH 86 DEGREES 19 MINUTES 34 SECONDS EAST, 209.00 FEET; THENCE SOUTH 85 DEGREES

THIRD INSERTION

19 MINUTES 06 SECONDS EAST, 142.91 FEET; THENCE SOUTH 00 DEGREES 00 MINUTES 24 SECONDS EAST, 259.69 FEET TO THE POINT OF BEGINNING. LESS ROAD RIGHT-OF-WAY. LESS THE EAST 46.37 FEET THEREOF. TOGETHER WITH THAT CERTAIN MOBILE HOME LOCATED THEREON AS A FIXTURE AND APPURTENANCE THERETO: 2000, FLEETWOOD, VIN# GAFLY-05A29787CH21 & GAFLY-05B29787CH21.  
has been filed against you and you are required to serve a copy of your written defenses, if any, on or before 04/21/2014 on Ronald R Wolfe & Associates, P.L., Plaintiff's attorney, whose address is 4919 Memorial Highway, Suite 200, Tampa, Florida 33634, and file the original with this Court either before service on Plaintiff's attorney or immediately thereafter; otherwise a default will be entered against you for the relief demanded in the Complaint or petition.  
This notice shall be published once each week for two consecutive weeks in the Business Observer.

THIRD INSERTION

\*\*See Americans with Disabilities Act  
\*If you are a person with a disability who needs an accommodation in order to participate in this proceeding, you are entitled, at no cost to you, to the provision of certain assistance. Please contact:  
Public Information Dept., Pasco County Government Center 7530 Little Rd. New Port Richey, FL 34654 Phone: 727.847.8110 (voice) in New Port Richey 352.521.4274, ext 8110 (voice) in Dade City Or 711 for the hearing impaired  
Contact should be initiated at least seven days before the scheduled court appearance, or immediately upon receiving this notification if the time before the scheduled appearance is less than seven days."  
WITNESS my hand and the seal of this Court on this 18 day of MAR, 2014.  
Paula S. O'Neil  
Clerk of the Court  
By: /s/ Susannah Hennessy  
As Deputy Clerk  
Invoice to & Copy to:  
Ronald R Wolfe & Associates, P.L.  
P.O. Box 25018  
Tampa, Florida 33622-5018  
G13003485  
Mar. 21, 28; Apr. 4, 11, 2014 14-01756P

SECOND INSERTION

NOTICE OF SALE IN THE COUNTY COURT OF THE 6TH JUDICIAL CIRCUIT IN AND FOR PASCO COUNTY, FLORIDA CASE NO.: 51-2013-CC-002503-ES SECTION: T

**NORTHWOOD OF PASCO HOMEOWNERS ASSOCIATION, INC., a non-for-profit Florida corporation, Plaintiff, vs. BALEWA MUHAMMAD; BEVERLY MUHAMMAD; et al Defendants**

NOTICE IS HEREBY GIVEN that, pursuant to the Final Judgment entered in this cause, in the County Court of Pasco County, Florida, I will sell all the property situated in Pasco County, Florida described as:  
Lot 20, Block D, NORTHWOOD UNIT 2B, according to

the Plat thereof as recorded in Plat Book 33, Pages 58 and 59, of the Public Records of Pasco County, Florida, and any subsequent amendments to the aforesaid.

at public sale, to the highest and best bidder, for cash, via the Internet at www.pasco.realforeclose.com at 11:00 A.M. on April 17th, 2014.

If you are a person with a disability who needs any accommodation in order to participate in this proceeding, you are entitled, at no cost to you, to the provision of certain assistance. Please contact the Public Information Dept., Pasco County Government Center, 7530 Little Rd., New Port Richey, FL 34654; (727) 847-8110 (V) in New Port Richey; (352) 521-4274, ext 8110 (V) in Dade City, at least 7 days before your scheduled

court appearance, or immediately upon receiving this notification if the time before the scheduled appearance is less than 7 days; if you are hearing impaired call 711. The court does not provide transportation and cannot accommodate for this service. Persons with disabilities needing transportation to court should contact their local public transportation providers for information regarding transportation services.

By BRANDON K. MULLIS, ESQ.  
Attorney for Plaintiff  
Email: Service@MankinLawGroup.com  
FBN: 23217

**MANKIN LAW GROUP**  
2535 Landmark Drive, Suite 212  
Clearwater, FL 33761  
(727) 725-0559  
Mar. 28; Apr. 4, 2014 14-01809P

SECOND INSERTION

NOTICE OF SALE IN THE COUNTY COURT OF THE SIXTH JUDICIAL CIRCUIT IN AND FOR PASCO COUNTY, FLORIDA CIVIL DIVISION

**Case No. 51-2013-CC-003292-ES**  
**Section T**  
**LAKE TALIA HOMEOWNERS ASSOCIATION, INC., a Florida non-profit corporation, Plaintiff, v. JOSEPH M. BELL, et al., Defendants.**

NOTICE IS HEREBY GIVEN that, pursuant to the Final Judgment of Foreclosure entered in this cause on March 20, 2014 by the County Court of Pasco County, Florida, the property described as:

Lot 5, Block 4, LAKE TALIA, PHASE 1, according to the plat thereof, as recorded in Plat Book 52, Page 1, of the Public Records of Pasco County, Florida  
Parcel Folio No. 13-26-18-0090-00400-0050  
Street Address: 21201 Tyrell Way, Land O'Lakes, Florida 34638

will be sold at public sale to the highest and best bidder, for cash, on April 24, 2014 at 11:00 A.M. at www.pasco.realforeclose.com.

Any person claiming an interest in the surplus from the sale, if any, other than the property owner as of the date of the Lis Pendens must file a claim within sixty (60) days after the sale.

In accordance with the Americans With Disabilities Act, persons with disabilities needing a special accommodation to participate in this proceeding should contact Dade City (352) 521-4274, Ext. 8110; New Port Richey (727) 847-8110; TDD 1-800-955-8771 via Florida Relay Service; no later than seven (7) days prior to any proceeding.

John S. Inglis, Esquire  
Florida Bar No. 0472336  
Shumaker, Loop & Kendrick, LLP  
101 E. Kennedy Blvd., Suite 2800  
Tampa, Florida 33602  
Phone: 813.227.2237  
Fax: 813.229.1660  
Primary E-Mail: jinglis@slk-law.com  
Attorneys for Plaintiff  
Mar. 28; Apr. 4, 2014 14-01923P

SECOND INSERTION

NOTICE OF SALE IN THE CIRCUIT COURT OF THE 6TH JUDICIAL CIRCUIT IN AND FOR PASCO COUNTY, FLORIDA, CIVIL ACTION

**CASE NO.: 51-2009-CA-009095-XXXX-ES**  
**BAC HOME LOANS SERVICING, LP, F/K/A COUNTRYWIDE HOME LOANS SERVICING, LP, Plaintiff vs. RAYMOND PAUL VILCSEK, LISA KIMBERLY VILCSEK, et al. Defendant(s)**

Notice is hereby given that, pursuant to an Order Rescheduling Foreclosure Sale dated March 5, 2014 entered in Civil Case Number 51-2009-CA-009095-XXXX-ES, in the Circuit Court for Pasco County, Florida, wherein BAC HOME LOANS SERVICING, LP, F/K/A COUNTRYWIDE HOME LOANS SERVICING, LP is the Plaintiff, and LISA KIMBERLY VILCSEK RAYMOND PAUL VILCSEK, et al., are the Defendants, Pasco County Clerk of Court - East Side will sell the property situated in Pasco County, Florida, described as:

LOT 12, BLOCK 1, ZEPHYR HEIGHTS, ACCORDING TO THE MAP OR PLAT THEREOF AS RECORDED IN PLAT BOOK 5, PAGE(S) 50, PUBLIC RECORDS OF PASCO COUNTY, FLORIDA.

at public sale, to the highest and best bidder, for cash, at www.pasco.realforeclose.com at 11:00 AM, on the 16th day of April, 2014. Any person claiming an interest in the surplus from the sale, if any, other than the property owner as of the date of the lis pendens must file a claim within 60 days after the sale.

If you are a person with a disability who needs any accommodation in order to participate in this proceeding, you are entitled, at no cost to you to the provision of certain assistance.

Within two (2) working days of your receipt of this (describe notice/order) please contact the Public Information Dept., Pasco County Government Center, 7530 Little Rd., New Port Richey, FL 34654; (727) 847-8110 (V) in New Port Richey; (352) 521-4274, ext. 8110 (V) in Dade City; via 1-800-955-8771 if you are hearing impaired. The court does not provide transportation and cannot accommodate for this service. Persons with disabilities needing transportation to court should contact their local public transportation providers for information regarding disabled transportation services.

Si uou se yon moun ki gen you andikap ki bezwen aranjman nenpòt nan lòd yo patisipe nan sa a pwosè dapèl, ou gen dwa, san sa pa koute ou nan dispozisyon pou asistans a sèten. Nan de (2) k ap travay jou apre yo resevwa ou nan sa a (deklari avè / lòd) tanpri kontakte Enfòmasyon Piblik la Dept, Gouvènman Konte Pasco Center, 7530 Little Rd, New Port Richey, FL 34654; (727) 847-8110 (V) nan New Port Richey; (352) 521-4274, ext. 8110 (V) nan Dade City; via 1-800-955-8771 si ou genyen pwoblèm pou tande. Tribinal la pa bay transpò epi yo pa kapab akomode pou sèvis sa a. Moun ki andikap ki bezwen transpò nan tribinal la ta dwe kontakte founisè lokal transpò yo piblik pou enfòmasyon konsènan sèvis transpò ki andikap.

Si vous êtes une personne handicapée qui a besoin d'une adaptation pour pouvoir participer à cette instance, vous avez le droit, sans frais pour vous à la fourniture d'une assistance certain. Dans les deux (2) jours ouvrables suivant la réception de la présente (décrire avis / ordre) s'il vous plaît contacter le Département de l'information publique, Pasco County Government Center, 7530 Rd Little, New Port Richey, FL 34654; (727) 847-8110 (V) à New Port Richey, (352) 521-4274, ext. 8110 (V) à Dade City, si vous êtes sourd ou malentendant. Le tribunal n'a pas assuré le transport et ne peut pas s'accommoder de ce service. Les personnes handicapées ont besoin transport vers le tribunal doit communiquer avec leurs fournisseurs locaux de transport en commun des informations concernant les services de transport à mobilité réduite.

FL 34654, (727) 847-8110 (V) à New Port Richey, (352) 521-4274, ext. 8110 (V) à Dade City, via 1-800-955-8771 si vous êtes sourd ou malentendant. Le tribunal n'a pas assuré le transport et ne peut pas s'accommoder de ce service. Les personnes handicapées ont besoin transport vers le tribunal doit communiquer avec leurs fournisseurs locaux de transport en commun des informations concernant les services de transport à mobilité réduite.

Si usted es una persona con una discapacidad que necesita cualquier acomodación para poder participar en este procedimiento, usted tiene derecho, sin costo alguno para usted a la prestación de asistencia determinada. Dentro de los dos (2) días hábiles siguientes a la recepción de esta (describir aviso / order) por favor póngase en contacto con el Departamento de Información Pública, Pasco County Government Center, 7530 Rd Little, New Port Richey, FL 34654; (727) 847-8110 (V) en New Port Richey, (352) 521-4274, ext. 8110 (V) en Dade City, a través 1-800-955-8771 si tiene problemas de audición. El tribunal no proporciona el transporte y no se puede acomodar para este servicio. Las personas con discapacidad que necesitan transporte a los tribunales deberán contactar a sus proveedores locales de transporte público para obtener información sobre los servicios de transporte con discapacidad.

Dated: March 26, 2014  
By: /s/ Mark Morales  
Mark Morales, Esquire  
(FBN 64982)  
**FLORIDA FORECLOSURE ATTORNEYS, PLLC**  
4855 Technology Way, Suite 500  
Boca Raton, FL 33431  
(727) 446-4826  
emailservice@ffaplpc.com  
Our File No: CA12-05301-T /CQ  
Mar. 28; Apr. 4, 2014 14-01921P

SECOND INSERTION

NOTICE OF RESCHEDULED SALE IN THE CIRCUIT COURT OF THE SIXTH JUDICIAL CIRCUIT IN AND FOR PASCO COUNTY, FLORIDA CIVIL ACTION

**CASE NO.: 51-2012-CA-002037-CAAX-WS**  
**DIVISION: J2 or J3**  
**BANK OF AMERICA, N.A., SUCCESSOR BY MERGER TO BAC HOME LOANS SERVICING, LP FKA COUNTRYWIDE HOME LOANS SERVICING, LP, Plaintiff, vs. MERCADO, YAIMAR I. et al. Defendant(s).**

NOTICE IS HEREBY GIVEN Pursuant to an Order Rescheduling Foreclosure Sale dated on or about March 4, 2014, and entered in Case No. 51-2012-CA-002037-CAAX-WS of the Circuit Court of the Sixth Judicial Circuit in and for Pasco County, Florida in which Bank of America, N.A., successor by merger to BAC Home Loans Servicing, LP fka Countrywide Home Loans Servicing, LP, is the Plaintiff and Bank of America, N.A., Enrique Saavedra, Forest Hills East Civic Association, Inc., Yaimar I. Mercado also known as Yaimar Mercado, are defendants, the Pasco County Clerk of the Circuit Court will sell to the highest and best bidder for cash held online www.pasco.realforeclose.com in Pasco County, Florida, Pasco County, Florida at 11:00AM on the 21st day of April 2014, the following described property as set forth in said Final Judgment of Foreclosure:

LOT 110, FOREST HILLS EAST UNIT 1, ACCORDING TO THE

PLAT THEREOF, AS RECORDED IN PLAT BOOK 13, PAGES 57 AND 58, OF THE PUBLIC RECORDS OF PASCO COUNTY, FL. TOGETHER WITH THE NORTHWEST ¼ OF THE NORTHEAST ¼ OF SECTION 32, TOWNSHIP 26 SOUTH, RANGE 16 EAST, BEING 50 FEET WIDE, 25 FEET ON EACH SIDE OF THE CENTERLINE OF SAID RIGHT-OF-WAY, BEGINNING AT A POINT 492.43 FEET, MORE OR LESS, FROM THE SOUTHERLY LINE OF CATSKILL ROAD (FORMERLY MILE STRETCH ROAD), AS MEASURED IN A SOUTHERLY DIRECTION ALONG GRANTOR'S CENTERLINE, SAID BEGINNING POINT BEING THE INTERSECTION OF GRANTOR'S CENTERLINE AND THE WESTERLY EXTENSION OF THE LINE BETWEEN LOTS 111 AND 110 OF FOREST HILLS EAST SUBDIVISION, AND EXTENDING 55.89 FEET, MORE OR LESS IN A SOUTHEASTLY DIRECTION AND ENDING WITH THE INTERSECTION OF GRANTOR'S CENTERLINE AND THE NORTH BOUNDARY OF MARLPOSA DRIVE (FORMERLY ELIZABETH AVENUE), ALSO BEING THE EXTENSION OF THE SOUTH LINE OF LOT 110, OF SAID FOREST HILLS EAST SUBDIVISION.

1903 TUMBLEWEED DR UNIT 1 HOLIDAY FL 34690-4530  
Any person claiming an interest in the surplus from the sale, if any, other than

the property owner as of the date of the Lis Pendens must file a claim within 60 days after the sale.

If you are a person with a disability who needs an accommodation in order to participate in this proceeding, you are entitled, at no cost to you, to the provision of certain assistance. Please contact:

Public Information Dept., Pasco County Government Center 7530 Little Rd. New Port Richey, FL 34654 Phone: 727.847.8110 (voice) in New Port Richey 352.521.4274, ext 8110 (voice) in Dade City Or 711 for the hearing impaired

Contact should be initiated at least seven days before the scheduled court appearance, or immediately upon receiving this notification if the time before the scheduled appearance is less than seven days.

The court does not provide transportation and cannot accommodate such requests. Persons with disabilities needing transportation to court should contact their local public transportation providers for information regarding transportation services.

Dated in Hillsborough County, Florida, this 26th day of March, 2014  
/s/ Erik Del'Etoile  
Erik Del'Etoile, Esq.  
FL Bar # 71675

Albertelli Law  
Attorney for Plaintiff  
P.O. Box 23028  
Tampa, FL 33623  
(813) 221-4743  
(813) 221-9171 facsimile  
eService: servealaw@albertellilaw.com  
JR- 002259F01  
Mar. 28; Apr. 4, 2014 14-01922P

SECOND INSERTION

NOTICE OF ACTION IN THE CIRCUIT COURT OF THE SIXTH JUDICIAL CIRCUIT, IN AND FOR PASCO COUNTY, FLORIDA

**CASE NO.: 51-2013-CA-003813 WS/J2**  
**WELLS FARGO BANK, N.A.; Plaintiff, vs. JETHRO J. ALBANO; JENNIFER ALBANO; ANY AND ALL UNKNOWN PARTIES CLAIMING BY, THROUGH, UNDER AND AGAINST THE HEREIN NAMED INDIVIDUAL DEFENDANT(S) WHO ARE NOT KNOWN TO BE DEAD OR ALIVE, WHETHER SAID UNKNOWN PARTIES MAY CLAIM AN INTEREST AS SPOUSES, HEIRS, DEVISEES, GRANTEES, OR OTHER CLAIMANTS; THE RIVER RIDGE HOMEOWNERS' ASSOCIATION, INC.; VILLAGES AT RIVER RIDGE ASSOCIATION, INC.; DEER RIDGE AT RIVER RIDGE PHASE I HOMEOWNERS ASSOCIATION, INC. FKA DEER RIDGE AT RIVER RIDGE HOMEOWNERS ASSOCIATION, INC.; UNKNOWN TENANT #1 IN POSSESSION OF THE PROPERTY; UNKNOWN TENANT #2 IN POSSESSION OF THE PROPERTY;**

**Defendants**  
To the following Defendant(s):  
JETHRO J. ALBANO,  
LAST KNOWN ADDRESS  
10551 MAGRATH LANE  
NEW PORT RICHEY, FLORIDA 34654

YOU ARE NOTIFIED that an action for Foreclosure of Mortgage on the following described property:

LOT 46, DEER RIDGE AT RIVER RIDGE, PHASE 1, ACCORDING TO THE PLAT THEREOF, AS RECORDED IN PLAT BOOK 32, PAGE(S) 114 THROUGH 116, OF THE PUBLIC RECORDS OF PASCO COUNTY, FLORIDA.  
a/k/a 10551 MAGRATH LANE, NEW PORT RICHEY, FLORIDA 34654

has been filed against you and you are required to serve a copy of you

written defenses, if any, to it, on Marinosci Law Group, P.C., Attorney for Plaintiff, whose address is 100 W. Cypress Creek Road, Suite 1045, Fort Lauderdale, Florida 33309, within thirty (30) days after the first publication of this Notice in the BUSINESS OBSERVER file the original with the Clerk of this Court either before service on Plaintiff's attorney or immediately thereafter; otherwise a default will be entered against you for the relief demanded in the complaint. On or before 4-28-14

This notice is provided pursuant to Administrative Order No. 2.065.

IN ACCORDANCE WITH THE AMERICANS WITH DISABILITIES ACT, If you are a person with a disability who needs any accommodation in order to participate in this proceeding, you are entitled, at no cost to you to the provision of certain assistance. Within two (2) working days of your receipt of this (describe notice/order) please contact the Public Information Dept., Pasco County Government Center, 7530 Little Rd., New Port Richey, FL 34654; (727) 847-8110 (V) in New Port Richey; (352) 521-4274, ext. 8110 (V) in Dade City; via 1-800-955-8771 if you are hearing impaired. The court does not provide transportation and cannot accommodate for this service. Persons with disabilities needing transportation to court should contact their local public transportation providers for information regarding disabled transportation services.

WITNESS my hand and the seal of this Court this 20 day of March, 2014.

PAULA S. O'NEIL  
As Clerk of the Court  
By /s/ Jonathon Martin  
As Deputy Clerk  
Submitted by:  
Marinosci Law Group, P.C.  
100 W. Cypress Creek Road,  
Suite 1045  
Fort Lauderdale, FL 33309  
Telephone: (954) 644-8704  
Telefacsimile: (954) 772-9601  
Our File Number: 13-04125  
Mar. 28; Apr. 4, 2014 14-01820P

SECOND INSERTION

NOTICE OF ACTION IN THE CIRCUIT COURT OF THE SIXTH JUDICIAL CIRCUIT IN AND FOR PASCO COUNTY, FLORIDA CIVIL ACTION

**CASE NO.: 51-2014-CA-000850WS**  
**DIVISION: J3**  
**JAMES B. NUTTER & COMPANY, Plaintiff, vs. HERMANN LEROY WINTHROP, et al. Defendant(s).**

TO: THE UNKNOWN HEIRS, DEVISEES, GRANTEES, ASSIGNEES, LIENORS, CREDITORS, TRUSTEES, OR OTHER CLAIMANTS CLAIMING BY, THROUGH, UNDER, OR AGAINST BARBARA STRONG WINTHROP A/K/A BARBARA JEAN WINTHROP A/K/A BARBARA J. WINTHROP A/K/A BARBARA VINSON WINTHROP, DECEASED  
LAST KNOWN ADDRESS:  
UNKNOWN  
CURRENT ADDRESS:  
UNKNOWN  
ANY AND ALL UNKNOWN PARTIES CLAIMING BY, THROUGH, UNDER, AND AGAINST THE HEREIN NAMED INDIVIDUAL DEFENDANT(S) WHO ARE NOT KNOWN TO BE DEAD OR ALIVE, WHETHER SAID UNKNOWN PARTIES MAY CLAIM AN INTEREST AS SPOUSES, HEIRS, DEVISEES, GRANTEES, OR OTHER CLAIMANTS  
LAST KNOWN ADDRESS:  
UNKNOWN  
CURRENT ADDRESS:  
UNKNOWN

YOU ARE NOTIFIED that an action to foreclose a mortgage on the following property in PASCO County, Florida: BEGIN AT A POINT 285.6 FEET NORTH AND 30 FEET EAST OF THE SOUTHWEST CORNER OF TRACT 58, SECTION 28, TOWNSHIP 25 SOUTH, RANGE 16 EAST, PASCO COUNTY, FLORIDA, AND RUN THENCE EAST 150 FEET; THENCE NORTH 60.3 FEET; THENCE WEST

150 FEET; THENCE SOUTH 60.3 FEET TO POINT OF BEGINNING, AS PER MAP OR PLAT THEREOF, RECORDED IN THE PUBLIC RECORDS OF PASCO COUNTY, FLORIDA.  
has been filed against you and you are required to serve a copy of your written defenses, if any, on or before 4-28-14, on Ronald R Wolfe & Associates, P.L., Plaintiff's attorney, whose address is 4919 Memorial Highway, Suite 200, Tampa, Florida 33634, and file the original with this Court either before service on Plaintiff's attorney or immediately thereafter; otherwise a default will be entered against you for the relief demanded in the Complaint or petition.  
This notice shall be published once each week for two consecutive weeks in the Business Observer.  
\*\*See Americans with Disabilities Act  
"If you are a person with a disability who needs an accommodation in order to participate in this proceeding, you are entitled, at no cost to you, to the provision of certain assistance. Please contact:  
Public Information Dept., Pasco County Government Center 7530 Little Rd. New Port Richey, FL 34654 Phone: 727.847.8110 (voice) in New Port Richey 352.521.4274, ext 8110 (voice) in Dade City Or 711 for the hearing impaired  
Contact should be initiated at least seven days before the scheduled court appearance, or immediately upon receiving this notification if the time before the scheduled appearance is less than seven days."  
WITNESS my hand and the seal of this Court on this 20 day of March, 2014.  
Paula S. O'Neil  
Clerk of the Court  
By: /s/ Jonathon Martin  
As Deputy Clerk  
Ronald R Wolfe & Associates, P.L.  
P.O. Box 25018  
Tampa, Florida 33622-5018  
F13017600  
Mar. 28; Apr. 4, 2014 14-01823P

SECOND INSERTION

NOTICE OF ACTION IN THE CIRCUIT COURT OF THE SIXTH JUDICIAL CIRCUIT IN AND FOR PASCO COUNTY, FLORIDA CIVIL ACTION

**CASE NO.: 51-2013-CA-006513WS**  
**DIVISION: J3**  
**NATIONSTAR MORTGAGE LLC, Plaintiff, vs. MICHELE SASSANELLI, et al. Defendant(s).**

TO: MICHELE SASSANELLI  
LAST KNOWN ADDRESS:  
4426 SUNSTATE DRIVE  
NEW PORT RICHEY, FL 34652  
CURRENT ADDRESS: UNKNOWN  
CARMELLA SASSANELLI  
LAST KNOWN ADDRESS:  
4426 SUNSTATE DRIVE  
NEW PORT RICHEY, FL 34652  
CURRENT ADDRESS: UNKNOWN  
ANY AND ALL UNKNOWN PARTIES CLAIMING BY, THROUGH, UNDER, AND AGAINST THE HEREIN NAMED INDIVIDUAL DEFENDANT(S) WHO ARE NOT KNOWN TO BE DEAD OR ALIVE, WHETHER SAID UNKNOWN PARTIES MAY CLAIM AN INTEREST AS SPOUSES, HEIRS, DEVISEES, GRANTEES, OR OTHER CLAIMANTS  
LAST KNOWN ADDRESS:  
UNKNOWN  
CURRENT ADDRESS: UNKNOWN  
YOU ARE NOTIFIED that an action to foreclose a mortgage on the following property in PASCO County, Florida:  
THAT CERTAIN CONDOMINIUM PARCEL DESCRIBED AS UNIT B, BUILDING 3083, OF GARDENS OF BEACON SQUARE CONDOMINIUM NUMBER FOUR, TOGETHER WITH AN UNDIVIDED INTEREST IN THE COMMON ELEMENTS APPURTENANT THERETO AS SET FORTH IN SAID DECLARATION, AND ANY AMENDMENTS THERETO, ACCORDING TO THE DECLARATION OF CONDOMINIUM OF GARDENS OF BEACON SQUARE CONDOMINIUM NUMBER FOUR, AS RECORDED IN OFFICIAL RECORD BOOK 588, PAGE 515,

AND AMENDED IN OFFICIAL RECORD BOOK 937, PAGE 226, AND AMENDED IN OFFICIAL RECORD BOOK 892, PAGE 324, AND THE PLAT THEREOF AS RECORDED IN PLAT BOOK 11, PAGES 7 THROUGH 11, ALL OF THE PUBLIC RECORDS OF PASCO COUNTY, FLORIDA  
has been filed against you and you are required to serve a copy of your written defenses, if any, on or before 4-28-14, on Ronald R Wolfe & Associates, P.L., Plaintiff's attorney, whose address is 4919 Memorial Highway, Suite 200, Tampa, Florida 33634, and file the original with this Court either before service on Plaintiff's attorney or immediately thereafter; otherwise a default will be entered against you for the relief demanded in the Complaint or petition.  
This notice shall be published once each week for two consecutive weeks in the Business Observer.  
\*\*See Americans with Disabilities Act  
"If you are a person with a disability who needs an accommodation in order to participate in this proceeding, you are entitled, at no cost to you, to the provision of certain assistance. Please contact:  
Public Information Dept., Pasco County Government Center 7530 Little Rd. New Port Richey, FL 34654 Phone: 727.847.8110 (voice) in New Port Richey 352.521.4274, ext 8110 (voice) in Dade City Or 711 for the hearing impaired  
Contact should be initiated at least seven days before the scheduled court appearance, or immediately upon receiving this notification if the time before the scheduled appearance is less than seven days."  
WITNESS my hand and the seal of this Court on this 20 day of March, 2014.  
Paula S. O'Neil  
Clerk of the Court  
By: /s/ Jonathon Martin  
As Deputy Clerk  
Ronald R Wolfe & Associates, P.L.  
P.O. Box 25018  
Tampa, Florida 33622-5018  
F13012194  
Mar. 28; Apr. 4, 2014 14-01824P

## SECOND INSERTION

NOTICE OF SALE  
IN THE CIRCUIT COURT OF  
THE SIXTH JUDICIAL CIRCUIT  
OF THE STATE OF FLORIDA, IN  
AND FOR PASCO COUNTY  
CIVIL DIVISION

CASE NO.

51-2013-CA-001162-CAAX-WS

FEDERAL NATIONAL

MORTGAGE ASSOCIATION,

Plaintiff, vs.

STEVEN ZIMMERMAN A/K/A

STEVEN J. ZIMMERMAN;

UNKNOWN SPOUSE OF

STEVEN ZIMMERMAN A/K/A

STEVEN J. ZIMMERMAN; IF

LIVING, INCLUDING ANY

UNKNOWN SPOUSE OF SAID

DEFENDANT(S), IF

REMARIED, AND IF

DECEASED, THE RESPECTIVE

UNKNOWN HEIRS, DEVISEES,

GRANTEES, ASSIGNEES,

CREDITORS, LIENORS, AND

TRUSTEES, AND ALL OTHER

PERSONS CLAIMING BY,

THROUGH, UNDER OR AGAINST

THE NAMED DEFENDANT(S);

CLERK OF THE CIRCUIT COURT

OF PASCO COUNTY; STATE OF

FLORIDA; SEVEN SPRINGS

VILLAS ASSOCIATION, INC.;

WHETHER DISSOLVED OR

PRESENTLY EXISTING,

TOGETHER WITH ANY

GRANTEES, ASSIGNEES,

CREDITORS, LIENORS,

OR TRUSTEES OF SAID

DEFENDANT(S) AND ALL

OTHER PERSONS CLAIMING

BY, THROUGH, UNDER, OR

AGAINST DEFENDANT(S);

UNKNOWN TENANT #1;

UNKNOWN TENANT #2;

Defendant(s)

Notice is hereby given that, pursuant

to a Final Summary Judgment of Fore-

closure entered on 02/19/2014 in the

above-styled cause, in the Circuit Court

of Pasco County, Florida, the office of

Paula S. O'Neil clerk of the circuit court

will sell the property situate in Pasco

County, Florida, described as:

LOT 50, SEVEN SPRINGS

HOMES UNIT ONE, AC-

CORDING TO THE PLAT

THEREOF, AS RECORDED

IN PLAT BOOK 12, PAGES

44-45, OF THE PUBLIC RE-

CORDS OF PASCO COUNTY,

FLORIDA.

at public sale, to the highest and best

bidder, for cash, www.pasco.realfore-

close.com at 11:00 o'clock, A.M., on

April 17, 2014

Any person claiming an interest

in the surplus from the sale, if any,

other than the property owner as of

the date of the lis pendens, must file

a claim within 60 days after the sale.

If you are a person with a disability

who needs any accommodation in order

to participate in this proceeding, you

are entitled, at no cost to you, to the

provision of certain assistance. Please

contact the Public Information Dept.,

Pasco County Government Center,

7530 Little Rd., New Port Richey,

FL 34654; (727) 847-8110 (V) for

proceedings in New Port Richey;

(352) 521-4274, ext. 8110 (V) for pro-

ceedings in Dade City, at least 7 days

before your scheduled court appear-

ance, or immediately upon receiving

this notification if the time before the

scheduled appearance is less than 7

days; if you are hearing impaired call

711.

Date: 03/25/2014

ATTORNEY FOR PLAINTIFF

By /s/ Josh D. Donnelly

Josh D. Donnelly

Florida Bar #64788

THIS INSTRUMENT PREPARED

BY:

Law Offices of Daniel C. Consuegra

9204 King Palm Drive

Tampa, FL 33619-1328

Phone: 813-915-8660

Attorneys for Plaintiff

142393

Mar. 28; Apr. 4, 2014 14-01907P

NOTICE OF FORECLOSURE SALE  
IN THE CIRCUIT COURT OF THE  
6TH JUDICIAL CIRCUIT, IN AND  
FOR PASCO COUNTY, FLORIDA  
CIVIL DIVISION:

CASE NO.:

51-2009-CA-002260ES

JPMORGAN CHASE BANK, N.A.,

Plaintiff, vs.

MARVIN REGINALD STEPHEN

FOSTER, JR. A/K/A MARVIN

REGINALD S. FOSTER, JR.;

EDGEWATER AT GRAND OAKS

HOMEOWNERS ASSOCIATION,

INC.; CYNTHIA J. FOSTER;

UNKNOWN TENANT(S) IN

POSSESSION OF THE SUBJECT

PROPERTY,

Defendants.

NOTICE IS HEREBY GIVEN

pursuant to Final Judgment of

Foreclosure dated the 5th day of

March, 2014, and entered in Case

No. 51-2009-CA-002260ES, of

the Circuit Court of the 6TH Ju-

dicial Circuit in and for Pasco

County, Florida, wherein FED-

ERAL NATIONAL MORTGAGE

ASSOCIATION is the Plaintiff

and MARVIN REGINALD STE-

PHEN FOSTER, JR. A/K/A MAR-

VIN REGINALD S. FOSTER, JR.;

EDGEWATER AT GRAND OAKS

HOMEOWNERS ASSOCIATION,

INC.; CYNTHIA J. FOSTER and

UNKNOWN TENANT(S) IN

POSSESSION OF THE SUBJECT

PROPERTY are defendants. The

Clerk of this Court shall sell to the

highest and best bidder for cash,

on the 23rd day of April, 2014, at

11:00 AM on Pasco County's Pub-

lic Auction website: www.pasco.

realforeclose.com, pursuant to

judgment or order of the Court,

in accordance with Chapter 45,

Florida Statutes, the following

described property as set forth in

said Final Judgment, to wit:

LOT 4, BLOCK 31, EDGEWA-

TER AT GRAND OAKS PHASE

2, AS PER PLAT THEREOF,  
RECORDED IN PLAT BOOK  
48, PAGE 1, OF THE PUBLIC  
RECORDS OF PASCO COUNTY,  
FLORIDA

ANY PERSON CLAIMING AN IN-

TEREST IN THE SURPLUS FROM

THE SALE, IF ANY, OTHER THAN

THE PROPERTY OWNER AS OF

THE DATE OF THE LIS PENDENS

MUST FILE A CLAIM WITHIN 60

DAYS AFTER THE SALE.

If you are a person with a disability

who needs any accommodation in order

to participate in this proceeding,

you are entitled, at no cost to you,

to the provision of certain assistance.

Please contact the Public Information

Dept., Pasco County Government

Center, 7530 Little Rd., New Port

Richey, FL 34654; (727) 847-8110 (V) in

New Port Richey; (352) 521-4274, ext

8110 (V) in Dade City, at least 7 days

before your scheduled court appear-

ance, or immediately upon receiving

this notification if the time before the

scheduled appearance is less than 7

days; if you are hearing impaired call

711. The court does not provide trans-

portation and cannot accommodate for

this service. Persons with disabilities

needing transportation to court should

contact their local public transpor-

tation providers for information regard-

ing transportation services.

Dated this 25 day of March, 2014.

By: Jennifer Nicole Tarquinio

Bar #99192

Submitted by:

Choice Legal Group, P.A.

P.O. Box 9908

Fort Lauderdale, FL 33310-9908

Telephone: (954) 453-0365

Facsimile: (954) 771-6052

Toll Free: 1-800-441-2438

DESIGNATED PRIMARY E-MAIL

FOR SERVICE PURSUANT TO FLA.

R. JUD. ADMIN 2.516

eservice@clegalgroup.com

09-14641

Mar. 28; Apr. 4, 2014 14-01910P

## SECOND INSERTION

RE-NOTICE OF  
FORECLOSURE SALE  
IN THE CIRCUIT COURT OF THE  
6TH JUDICIAL CIRCUIT, IN AND  
FOR PASCO COUNTY, FLORIDA  
CIVIL DIVISION:

CASE NO.:

51-2009-CA-001116ES

BAC HOME LOANS SERVICING,

LP,

Plaintiff, vs.

YURIY BOYECHKO A/K/A

Y. BOYECHKO; PALM

COVE OF WESLEY CHAPEL

HOMEOWNERS ASSOCIATION,

INC.; PULTE HOME

CORPORATION;

NATALIA BOYECHKO A/K/A

N. BOYECHKO; UNKNOWN

TENANT(S) IN POSSESSION OF

THE SUBJECT PROPERTY,

Defendants.

NOTICE IS HEREBY GIVEN

pursuant to an Order Resetting Fore-

closure Sale dated the 19th day of

March, 2014, and entered in Case

No. 51-2009-CA-001116ES, of the

Circuit Court of the 6TH Judicial

Circuit in and for Pasco County, Fla-

orida, wherein BAC HOME LOANS

SERVICING, LP is the Plaintiff and

YURIY BOYECHKO PALM COVE

OF WESLEY CHAPEL HOM-

EOWNERS ASSOCIATION, INC.

PULTE HOME CORPORATION

NATALIA BOYECHKO; and UN-

KNOWN TENANT(S) A/K/A MI-

CHAEL PARKS IN POSSESSION OF

THE SUBJECT PROPERTY are

defendants. The Clerk of this Court

shall sell to the highest and best

bidder for cash, on the 24th day of

April, 2014, at 11:00 AM on Pasco

County's Public Auction website:

www.pasco.

realforeclose.com, pursuant to

judgment or order of the Court, in

accordance with Chapter 45, Florida

Statutes, the following described

property as set forth in said Final

Judgment, to wit:

LOT 2, BLOCK 11, PALM COVE

PHASE 1B, ACCORDING TO

THE PLAT THEREOF AS RE-

CORDED IN PLAT BOOK 52,

PAGES 15 THROUGH 27, OF

THE PUBLIC RECORDS OF

PASCO COUNTY, FLORIDA.

ANY PERSON CLAIMING AN IN-

TEREST IN THE SURPLUS FROM

THE SALE, IF ANY, OTHER THAN

THE PROPERTY OWNER AS OF

THE DATE OF THE LIS PENDENS

MUST FILE A CLAIM WITHIN 60

DAYS AFTER THE SALE.

If you are a person with a disability

who needs any accommodation in order

to participate in this proceeding,

you are entitled, at no cost to you,

to the provision of certain assistance.

Please contact the Public Information

Dept., Pasco County Government

Center, 7530 Little Rd., New Port

Richey, FL 34654; (727) 847-8110 (V) in

New Port Richey; (352) 521-4274, ext

8110 (V) in Dade City, at least 7 days

before your scheduled court appear-

ance, or immediately upon receiving

this notification if the time before the

scheduled appearance is less than 7

</

SECOND INSERTION

NOTICE OF FORECLOSURE SALE IN THE CIRCUIT COURT OF THE 6TH JUDICIAL CIRCUIT, IN AND FOR PASCO COUNTY, FLORIDA GENERAL JURISDICTION DIVISION  
**CASE NO:**  
**51-2012-CA-000383-CAAX-ES**  
**THE BANK OF NEW YORK MELLON FKA THE BANK OF NEW YORK AS TRUSTEE FOR THE CERTIFICATEHOLDERS OF THE CWABS, INC., ASSET-BACKED CERTIFICATES, SERIES 2004-9, Plaintiff, vs. RICK SPECTOR, UNKNOWN SPOUSE OF RICK SPECTOR, MORTGAGE ELECTRONIC REGISTRATION SYSTEMS, INC. (MIN # REDACTED), LAKE PADGETT ESTATES CIVIC ASSOCIATION, IN C. UNKNOWN TENANT(S) IN POSSESSION #1 and #2, and ALL OTHER UNKNOWN PARTIES, including, if a named Defendant is deceased, the personal representatives, the surviving spouse, the heirs, devisees, grantees, creditors, and all other parties claiming, by through, under or against that Defendant, and all claimants, persons or parties, natural or corporate, or whose exact legal status is unknown, claiming under any of the above named or described Defendants, Defendant(s)**  
 NOTICE IS HEREBY GIVEN pursuant to an Order Granting Plaintiff's Motion to Reschedule the Foreclosure Sale Date entered in Civil Case No. 51-2012-CA-000383-CAAX-ES of the Circuit Court of the 6TH Judicial Circuit in and for Pasco County, Florida, wherein THE BANK OF

NEW YORK MELLON FKA THE BANK OF NEW YORK AS TRUSTEE FOR THE CERTIFICATEHOLDERS OF THE CWABS, INC., ASSET-BACKED CERTIFICATES, SERIES 2004-9 is Plaintiff and RICK SPECTOR, et al, are Defendants. The Clerk shall sell to the highest and best bidder for cash at Pasco County's Public Auction website: www.pasco.realforeclose.com., at 11:00 AM on the April 16, 2014, in accordance with Chapter 45, Florida Statutes, the following described property as set forth in said Uniform Final Judgment of Foreclosure, to-wit:  
 LOT 1147, LAKE PADGETT ESTATES, UNRECORDED BEING FURTHER DESCRIBED AS FOLLOWS: BEGIN 1820.39 FEET SOUTH AND 219.21 FEET EAST OF THE NORTHWEST CORNER OF SECTION 19; TOWNSHIP 26 SOUTH, RANGE 19 EAST, PASCO COUNTY, FLORIDA; THENCE NORTH 89°38' WEST 153.54; THENCE SOUTH 40°46'15" WEST 203.55 FEET; THENCE SOUTH 89°38' EAST 55.05 FEET, THENCE ALONG THE ARC OF A CUL-DE-SAC WITH A CORD BEARING 71°01'32" EAST, 75.48 FEET; THENCE SOUTH 89°38' EAST, 88.86 FEET; THENCE NORTH 28°47' EAST, 147.81 FEET TO THE POINT OF BEGINNING; SAID LANDS BEING LOCATED WITHIN SECTION 19, TOWNSHIP 26 SOUTH, RANGE 19 EAST AND SECTION 24, TOWNSHIP 26 SOUTH, RANGE 18 EAST.

Property Address: 22011 Darley Place Land O Lakes, FL 34639  
 Any person claiming an interest in the surplus from the sale, if any, other than the property owner as of the date of the lis pendens, must file a claim within 60 days after the sale.  
 If you are a person with a disability who needs any accommodation in order to participate in this proceeding, you are entitled, at no cost to you, to the provision of certain assistance. Please contact: Public Information Dept., Pasco County Government Center, 7530 Little Rd. New Port Richey, FL 34654. Phone: 727.847.8110 (voice) in New Port Richey 352.521.4274, ext 8110 (voice) in Dade City Or 711 for the hearing impaired. Contact should be initiated at least seven days before your scheduled court appearance, or immediately upon receiving this notification if the time before the scheduled appearance is less than seven days.  
 The court does not provide transportation and cannot accommodate for this service. Persons with disabilities needing transportation to court should contact their local public transportation providers for information regarding transportation services.  
 Angela Vittiglio, Esq.  
 FL Bar #: 51657  
**FRENKEL LAMBERT WEISS WEISMAN & GORDON, LLP**  
 One East Broward Blvd, Suite 1111 Fort Lauderdale, Florida 33301  
 Tel: (954) 522-3233 |  
 Fax: (954) 200-7770  
 DESIGNATED PRIMARY E-MAIL FOR SERVICE PURSUANT TO FL.A.R. JUD. ADMIN 2.516 flservice@flwlaw.com  
 Mar. 28; Apr. 4, 2014 14-01835P

NOTICE OF SALE IN THE CIRCUIT COURT OF THE 6th JUDICIAL CIRCUIT IN AND FOR PASCO COUNTY, FLORIDA, CIVIL ACTION  
**CASE NO.:**  
**51-2011-CA-005637-XXXX-WS**  
**BANK OF AMERICA, N.A., AS SUCCESSOR BY MERGER TO BAC HOME LOANS SERVICING, LP, Plaintiff vs. DIANE BACCILE, et al. Defendant(s)**  
 Notice is hereby given that, pursuant to a Final Judgment of Foreclosure dated March 5, 2014, entered in Civil Case Number 51-2011-CA-005637-XXXX-WS, in the Circuit Court for Pasco County, Florida, wherein BANK OF AMERICA, N.A., AS SUCCESSOR BY MERGER TO BAC HOME LOANS SERVICING, LP is the Plaintiff, and DIANE BACCILE, et al., are the Defendants, Pasco County Clerk of Court - West will sell the property situated in Pasco County, Florida, described as:  
 LOTS 13 AND 14, BLOCK 89, CITY OF NEW PORT RICHEY, ACCORDING TO THE PLAT THEREOF RECORDED IN PLAT BOOK 4, PAGE 49, OF THE PUBLIC RECORDS OF PASCO COUNTY, FLORIDA.  
 at public sale, to the highest and best bidder, for cash, at www.pasco.realforeclose.com at 11:00 AM, on the 6th day of June, 2014. Any person claiming an interest in the surplus from the sale, if any, other than the property owner as of the date of the lis pendens must file a claim within 60 days after the sale.  
 If you are a person with a disability who needs any accommodation in order to participate in this proceeding, you are entitled, at no cost to you to the provision of certain assistance. Within two (2) working days of your receipt of this (describe notice/order)

please contact the Public Information Dept., Pasco County Government Center, 7530 Little Rd., New Port Richey, FL 34654; (727) 847-8110 (V) in New Port Richey; (352) 521-4274, ext. 8110 (V) in Dade City; via 1-800-955-8771 if you are hearing impaired. The court does not provide transportation and cannot accommodate for this service. Persons with disabilities needing transportation to court should contact their local public transportation providers for information regarding disabled transportation services.  
 Si ou se yon moun ki gen yon andikap ki bezwen aranjman nenpòt nan lòd pou patisipe nan sa a pwosè dapèl, ou gen dwa, san sa pa koute ou nan dispozisyon pou asistans a sèten. Nan de (2) k ap travay jou apre you resevwa ou nan sa a (dekri avi / lòd) tanpri kontakte Enfòmasyon Piblik la Dept, Gouvènman Konte Pasco Center, 7530 Little Rd, New Port Richey, FL 34654. (727) 847-8110 (V) nan New Port Richey; (352) 521-4274, ext. 8110 (V) nan Dade City; via 1-800-955-8771 si ou genyen pwoblèm pou tande. Tribinal la pa bay transpò epi you pa kapab akomodè pou sèvis sa a. Moun ki andikape ki bezwen transpò nan tribinal la ta dwe kontakte founisè lokal transpò you piblik pou enfòmasyon konsènan sèvis transpò ki andikape.  
 Si vous êtes une personne handicapée qui a besoin d'une adaptation pour pouvoir participer à cette instance, vous avez le droit, sans frais pour vous à la fourniture d'une assistance certain. Dans les deux (2) jours ouvrables suivant la réception de la présente (décrire avis / ordre) s'il vous plaît contacter le Département de l'information publique, Pasco County Government Center, 7530 Rd Little, New Port Richey, FL 34654. (727) 847-8110 (V) à New Port Richey,

(352) 521-4274, ext. 8110 (V) à Dade City, via 1-800-955-8771 si vous êtes sourd ou malentendant. Le tribunal n'a pas assuré le transport et ne peut pas s'accommoder de ce service. Les personnes handicapées ont besoin transport vers le tribunal doit communiquer avec leurs fournisseurs locaux de transport en commun des informations concernant les services de transport à mobilité réduite.  
 Si usted es una persona con una discapacidad que necesita cualquier acomodación para poder participar en este procedimiento, usted tiene derecho, sin costo alguno para usted a la prestación de asistencia determinada. Dentro de los dos (2) días hábiles siguientes a la recepción de esta (describir aviso / order) por favor póngase en contacto con el Departamento de Información Pública, Pasco County Government Center, 7530 Rd Little, New Port Richey, FL 34654. (727) 847-8110 (V) en New Port Richey, (352) 521-4274, ext. 8110 (V) en Dade City, a través 1-800-955-8771 si tiene problemas de audición. El tribunal no proporciona el transporte y no se puede acomodar para este servicio. Las personas con discapacidad que necesitan transporte a los tribunales deberán contactar a sus proveedores locales de transporte público para obtener información sobre los servicios de transporte con discapacidad.  
 Dated: March 24, 2014  
 By: /s/ Erik T. Silevitch  
 Erik T. Silevitch, Esquire  
 (FBN 92048)  
**FLORIDA FORECLOSURE ATTORNEYS, PLLC**  
 4855 Technology Way, Suite 500 Boca Raton, FL 33431  
 (727) 446-4826  
 emailservice@ffaplcc.com  
 Our File No: CA12-05482-T/CQ  
 Mar. 28; Apr. 4, 2014 14-01859P

SECOND INSERTION

NOTICE OF SALE PURSUANT TO CHAPTER 45 IN THE CIRCUIT COURT OF THE SIXTH JUDICIAL CIRCUIT IN AND FOR PASCO COUNTY, FLORIDA CIVIL ACTION  
**CASE NO.:**  
**51-2013-CA-001600-CAAX-WS**  
**JPMORGAN CHASE BANK, NATIONAL ASSOCIATION, Plaintiff, vs. KROEN, HAROLD et al, Defendant(s).**  
 NOTICE IS HEREBY GIVEN Pursuant to a Final Judgment of Foreclosure dated February 26, 2014, and entered in Case No. 51-2013-CA-001600-CAAX-WS of the Circuit Court of the Sixth Judicial Circuit in and for Pasco County, Florida in which JPMorgan Chase Bank, National Association, is the Plaintiff and Betty Lee Harper, Christina L. Kroen also known as Christina L. McKee also known as Christina Lynn McKee, Harold Kroen also known as Harold William Kroen, Mary A. Kroen., are defendants, the Pasco County Clerk of the Circuit Court will sell to the highest and best bidder for cash in/on held online www.pasco.realforeclose.com: in Pasco County, Florida, Pasco County, Florida at 11:00AM on the 14th day of April, 2014, the following described property as set forth in said Final Judgment of Foreclosure:  
 PARCEL B, BEING A PORTION OF TRACT 480 OF THE UNRECORDED PLAT OF THE HIGHLANDS, LOCATED IN SECTION 14, TOWNSHIP 24 SOUTH, RANGE 17 EAST, BEING FURTHER DESCRIBED AS FOLLOWS: PARCEL B: COMMENCING AT THE NORTHWEST CORNER OF SECTION 14, TOWNSHIP 24 SOUTH, RANGE 17 EAST, PASCO COUNTY, FLORIDA; GO THENCE SOUTH 00 DEGREES 48 MINUTES 38 SECONDS WEST, ALONG THE WEST LINE OF SAID SECTION 14, A DISTANCE OF 1947.47 FEET; THENCE RUN SOUTH 89 DEGREES 23 MINUTES 20 SECONDS EAST, A DISTANCE OF 1947.47 FEET; THENCE RUN SOUTH 89 DEGREES 23 MINUTES 20 SECONDS EAST, A DISTANCE OF 1080.14 FEET; THENCE RUN SOUTH 00 DEGREES 26 MINUTES 05 SECONDS EAST, A DISTANCE OF 188.25 FEET TO THE POINT

OF BEGINNING; CONTINUE THENCE SOUTH 00 DEGREES 26 MINUTES 05 SECONDS EAST, A DISTANCE OF 163.25 FEET; THENCE NORTH 89 DEGREES 23 MINUTES 20 SECONDS WEST, A DISTANCE OF 255.00 FEET; THENCE RUN NORTH 00 DEGREES 26 MINUTES 05 SECONDS WEST, A DISTANCE OF 163.13 FEET; RUN THENCE SOUTH 89 DEGREES 23 MINUTES 20 SECONDS EAST, A DISTANCE OF 255.00 FEET TO THE POINT OF BEGINNING. SUBJECT TO AN EASEMENT OVER THE EAST 30.00 FEET THEREOF FOR INGRESS-EGRESS PURPOSES. TOGETHER WITH AN EASEMENT OVER THE EAST 30.00 FEET OF PARCEL A, BEING FURTHER DESCRIBED AS FOLLOWS: PARCEL A: COMMENCING AT THE NORTHWEST CORNER OF SECTION 14, TOWNSHIP 24 SOUTH, RANGE 17 EAST, PASCO COUNTY, FLORIDA; GO THENCE SOUTH 00 DEGREES 48 MINUTES 38 SECONDS WEST, ALONG THE WEST LINE OF SAID SECTION 14, A DISTANCE OF 1947.47 FEET; THENCE RUN SOUTH 89 DEGREES 23 MINUTES 20 SECONDS WEST, ALONG THE WEST LINE OF SAID SECTION 14, A DISTANCE OF 825.14 FEET TO THE POINT OF BEGINNING; CONTINUE THENCE SOUTH 89 DEGREES 23 MINUTES 20 SECONDS EAST, A DISTANCE OF 188.25 FEET; THENCE RUN NORTH 89 DEGREES 23 MINUTES 20 SECONDS EAST, A DISTANCE OF 255.00 FEET; THENCE RUN NORTH 00 DEGREES 26 MINUTES 05 SECONDS WEST, A DISTANCE OF 188.12 FEET TO THE POINT OF BEGINNING, EXCEPTING THE NORTHERLY 25.00 FEET TO BE USED FOR ROAD RIGHT-OF-WAY PURPOSES AND SUBJECT TO AN EASEMENT OVER THE EAST 30.00 FEET THEREOF FOR

INGRESS-EGRESS PURPOSES. TOGETHER WITH A MOBILE HOME AS A PERMANENT FIXTURE AND APPURTENANCE THERETO, DESCRIBED AS: A 1986 BERK DOUBLEWIDE MOBILE HOME BEARING IDENTIFICATION NUMBER(S) FLFL2AF353207443 AND FLFL2BF353207443 AND TITLE NUMBER(S) 0042457226 AND 0042418377.  
 16541 LYNNWAY LN, SPRING HILL, FL 34610-8511  
 Any person claiming an interest in the surplus from the sale, if any, other than the property owner as of the date of the Lis Pendens must file a claim within 60 days after the sale.  
 If you are a person with a disability who needs an accommodation in order to participate in this proceeding, you are entitled, at no cost to you, to the provision of certain assistance. Please contact:  
 Public Information Dept., Pasco County Government Center 7530 Little Rd. New Port Richey, FL 34654 Phone: 727.847.8110 (voice) in New Port Richey 352.521.4274, ext 8110 (voice) in Dade City Or 711 for the hearing impaired  
 Contact should be initiated at least seven days before the scheduled court appearance, or immediately upon receiving this notification if the time before the scheduled appearance is less than seven days.  
 The court does not provide transportation and cannot accommodate such requests. Persons with disabilities needing transportation to court should contact their local public transportation providers for information regarding transportation services.  
 Dated in Hillsborough County, Florida, this 24th day of March, 2014  
 /s/ Erik Del'Etoile  
 Erik Del'Etoile, Esq.  
 FL Bar # 71675  
 Albertelli Law  
 Attorney for Plaintiff  
 P.O. Box 23028  
 Tampa, FL 33623  
 (813) 221-4743  
 (813) 221-9171 facsimile  
 eService: servealaw@albertellilaw.com  
 BM - 007418F01  
 Mar. 28; Apr. 4, 2014 14-01864P

NOTICE OF SALE IN THE CIRCUIT COURT OF THE SIXTH JUDICIAL CIRCUIT IN AND FOR PASCO COUNTY CIVIL DIVISION  
**CASE NO.**  
**51-2010-CA-006296-CAAX-WS**  
**PROVIDENT FUNDING ASSOCIATES, L.P., Plaintiff, vs. MELISSA A. TARTAGLIA; UNKNOWN SPOUSE OF MELISSA A. TARTAGLIA; ANTHONY M. TARTAGLIA; UNKNOWN SPOUSE OF ANTHONY M. TARTAGLIA; IF LIVING, INCLUDING ANY UNKNOWN SPOUSE OF SAID DEFENDANT(S), IF REMARRIED, AND IF DECEASED, THE RESPECTIVE UNKNOWN HEIRS, DEVISEES, GRANTEES, ASSIGNEES, CREDITORS, LIENORS, AND TRUSTEES, AND ALL OTHER PERSONS CLAIMING BY, THROUGH, UNDER OR AGAINST THE NAMED DEFENDANT(S); UNKNOWN TENANT #1; UNKNOWN TENANT #2; Defendant(s)**  
 Notice is hereby given that, pursuant to a Final Summary Judgment of Foreclosure entered on 02/26/2014 in the above-styled cause, in the Circuit Court of Pasco County, Florida, the office of Paula S. O'Neil clerk of the circuit court will sell the property situate in Pasco County, Florida, described as:  
 A PORTION OF TRACT 8, GOLDEN ACRES UNIT ONE, ACCORDING TO THE MAP OR PLAT THEREOF RECORDED IN PLAT BOOK 7, PAGE 82, PASCO COUNTY, FLORIDA, COMMENCE AT THE MOST SOUTHERLY CORNER OF TRACT 8, THENCE RUN ALONG THE EASTERLY BOUNDARY OF SAID TRACT 8, NORTH 20 DEGREES 06 MINUTES 48 SECONDS EAST 401.00 FEET; THENCE NORTH 69 DEGREES 53 MINUTES 12 SECONDS WEST, A DISTANCE OF 425.80 FEET FOR A POINT OF BEGINNING, THENCE CONTIN-

UE NORTH 69 DEGREES 53 MINUTES 12 SECONDS WEST, A DISTANCE OF 85.00 FEET; THENCE NORTH 19 DEGREES 17 MINUTES 07 SECONDS EAST, A DISTANCE OF 287.91 FEET; THENCE ALONG THE SOUTHERLY BOUNDARY OF ADDITIONAL RIGHT-OF-WAY PARCEL 239B PER OFFICIAL RECORDS BOOK 3127, PAGE 1250, SOUTH 53 DEGREES 52 MINUTES 16 SECONDS EAST 150.45 FEET; THENCE SOUTH 32 DEGREES 46 MINUTES 35 SECONDS WEST 252.56 FEET TO THE POINT OF BEGINNING.  
 LESS AND EXCEPT THE FOLLOWING:  
 A PORTION OF TRACT 8, GOLDEN ACRES UNIT ONE, ACCORDING TO THE MAP OR PLAT THEREOF RECORDED IN PLAT BOOK 7, PAGE 82, OF THE PUBLIC RECORDS OF PASCO COUNTY, FLORIDA, SECTION 14, TOWNSHIP 25 SOUTH, RANGE 16 EAST, PASCO COUNTY, FLORIDA, BEING MORE PARTICULARLY DESCRIBED AS FOLLOWS:  
 COMMENCE AT THE SOUTHERN MOST CORNER OF TRACT 8, SAID POINT ALSO BEING ON THE EXISTING WESTERLY RIGHT-OF-WAY LINE OF LITTLE ROAD, THENCE RUN NORTH 19 DEGREES 30 MINUTES 47 SECONDS EAST 401.00 FEET; THENCE NORTH 70 DEGREES 29 MINUTES 13 SECONDS WEST, A DISTANCE OF 425.80 FEET TO THE GRANTORS SOUTHERN MOST PROPERTY CORNER; THENCE NORTH 32 DEGREES 10 MINUTES 34 SECONDS EAST, A DISTANCE OF 252.56 FEET FOR THE POINT OF BEGINNING OF THE PARCEL HEREIN DESCRIBED:  
 THENCE NORTH 54 DE-

GREES 28 MINUTES 17 SECONDS WEST, A DISTANCE OF 150.45 FEET TO A POINT, SAID POINT BEING ON THE EXISTING SOUTH RIGHT-OF-WAY LINE OF JASMINE BLVD, THENCE ALONG THE EXISTING SOUTH RIGHT OF WAY LINE OF JASMINE BLVD SOUTH 60 DEGREES 11 MINUTES 36 SECONDS EAST, A DISTANCE OF 150.32 FEET; THENCE SOUTH 32 DEGREES 10 MINUTES 34 SECONDS WEST, A DISTANCE OF 15.01 FEET TO THE POINT OF BEGINNING.  
 at public sale, to the highest and best bidder, for cash, www.pasco.realforeclose.com at 11:00 o'clock, A.M, on April 17, 2014  
 Any person claiming an interest in the surplus from the sale, if any, other than the property owner as of the date of the lis pendens, must file a claim within 60 days after the sale.  
 If you are a person with a disability who needs any accommodation in order to participate in this proceeding, you are entitled, at no cost to you, to the provision of certain assistance. Please contact the Public Information Dept., Pasco County Government Center, 7530 Little Rd., New Port Richey, FL 34654; (727) 847-8110 (V) for proceedings in New Port Richey; (352) 521-4274, ext. 8110 (V) for proceedings in Dade City, at least 7 days before your scheduled court appearance, or immediately upon receiving this notification if the time before the scheduled appearance is less than 7 days; if you are hearing impaired call 711.  
 Date: 03/25/2014  
 ATTORNEY FOR PLAINTIFF  
 By /s/ Josh D. Donnelly  
 Josh D. Donnelly  
 Florida Bar #64788  
 THIS INSTRUMENT PREPARED BY:  
 Law Offices of Daniel C. Consuegra  
 9204 King Palm Drive  
 Tampa, FL 33619-1328  
 Phone: 813-915-8660  
 Attorneys for Plaintiff  
 68857  
 Mar. 28; Apr. 4, 2014 14-01905P

SECOND INSERTION

NOTICE OF ACTION FOR DISSOLUTION OF MARRIAGE IN THE CIRCUIT COURT OF THE SIXTH JUDICIAL CIRCUIT, IN AND FOR PASCO COUNTY, FLORIDA  
**Case No.:**  
**512014DR1395WS**  
**Division: B**  
**JOHN E LEMON, Petitioner, and ELIZABETH CAROL LEMON, Respondent.**  
 TO: ELIZABETH CAROL LEMON 4457 MARINE PARKWAY, NEW PORT RICHEY, FL 34652  
 YOU ARE NOTIFIED that an action has been filed against you and that you are required to serve a copy of your written defenses, if any, to it on JOHN E LEMON, whose address is 4457 MARINE PARKWAY, NEW PORT RICHEY, FL 34652 on or be-

fore 4-28-2014 and file the original with the clerk of this Court at West Pasco Judicial Center 7530 Little Road, New Port Richey, FL 34654, before service on Petitioner or immediately thereafter. If you fail to do so, a default may be entered against you for the relief demanded in the petition.  
 The action is asking the court to decide how the following real or personal property should be divided:  
 (insert "none" or, if applicable, the legal description of real property, a specific description of personal property, and the name of the county in Florida where the property is located)  
 Copies of all court documents in this case, including orders, are available at the Clerk of the Circuit Court's office. You may review these documents upon request.  
 You must keep the Clerk of the

Circuit Court's office notified of your current address. (You may file Notice of Current Address, Florida Supreme Court Approved Family Law Form 12.915.) Future papers in this lawsuit will be mailed to the address on record at the clerk's office.  
 WARNING: Rule 12.285, Florida Family Law Rules of Procedure, requires certain automatic disclosure of documents and information. Failure to comply can result in sanctions, including dismissal or striking of pleadings.  
 If you are a person with a disability who needs any accommodation in order to participate in this proceeding, you are entitled, at no cost to you, to the provision of certain assistance. Please contact the Public Information Dept., Pasco County Government Center, 7530 Little Rd., New Port Richey, FL 34654;

(727) 847-8110 (V) in New Port Richey; (352) 521-4274, ext 8110 (V) in Dade City, at least 7 days before your scheduled court appearance, or immediately upon receiving this notification if the time before the scheduled appearance is less than 7 days; if you are hearing impaired call 711. The court does not provide transportation and cannot accommodate for this service. Persons with disabilities needing transportation to court should contact their local public transportation providers for information regarding transportation services.  
 Dated: MAR 24 2014  
 Paula S. O'Neil, Ph.D., Clerk & Comptroller  
 CLERK OF THE CIRCUIT COURT  
 By: /s/ Jennifer Lashley  
 Deputy Clerk  
 Mar.28; Apr.4,11,18,2014 14-01873P

**Subscribe to the Business Observer...**  
 Visit our website at **Businessobserverfl.com** to sign up today!

# GULF COAST Businesses

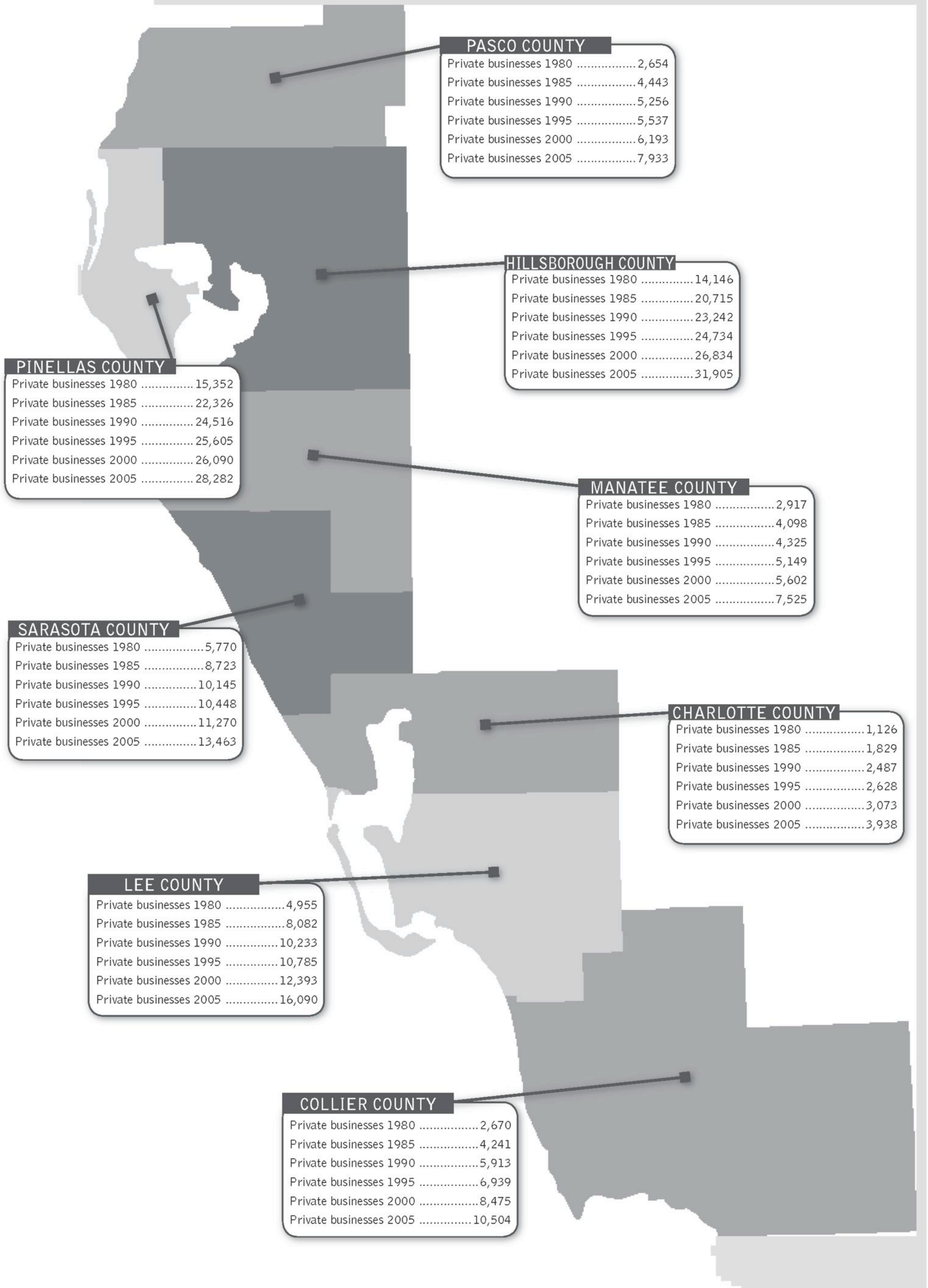

The following eight pages are special reprintings from the Business Review's collection of essays on capitalism:

"Strife as a way of life" by Leonard Read  
 "What spending & deficits do" by Henry Hazlitt  
 "The 'bad' people behind inflation" by Ludwig Von Mises

# STRIFE AS A WAY OF LIFE

by Leonard Read

Abandon the ideal of peace and harmony, and the only alternative is to embrace strife and violence. Plunder, spoliation, special privilege, doing one's own brand of good with the fruits of the labor of others — these all fall within strife and violence.

Broadly speaking, there are two opposing philosophies of human relationships. One commends that these relationships be in terms of peace and harmony. The other, while never overtly commended, operates by way of strife and violence.

One is peaceful; the other unpeaceful.

When peace and harmony are adhered to, only willing exchange exists in the marketplace — the economics of reciprocity and practice of the Golden Rule. No special privilege is countenanced. All men are equal before the law, as before God.

The life and the livelihood of a minority of one enjoys the same respect as the lives and livelihoods of majorities, for such rights are, as set forth in the Declaration of Independence, conceived to be an endowment of the Creator. Everyone is completely free to act creatively as his abilities and ambitions permit; no restraint in this respect — none whatsoever.

Abandon the ideal of peace and harmony, and the only alternative is to embrace strife and violence, expressed ultimately as robbery and murder. Plunder, spoliation, special privilege, feathering one's own nest at the expense of others, doing one's own brand of good with the fruits of the labor of others — coercive, destructive and unpeaceful schemes of all sorts — fall within the order of strife and violence.

Are we abandoning the ideal of peace and harmony and drifting into the practice of strife and violence as a way of life? That's the question to be examined in this chapter — and answered in the affirmative.

At the outset, it is well to ask why so few people are seriously concerned about this trend. William James may have suggested the reason: "Now, there is a striking law over which few people seem to have pondered. It is this: That among all the differences which exist, the only ones that interest us strongly are those we do not take for granted."

Socialistic practices are now so ingrained in our thinking, so customary, so much a part of our mores, that we take them for granted. No longer do we ponder them; no longer do we even suspect that they are founded on strife and violence. Once a socialistic practice has been Americanized, it becomes a member of the family so to speak and, as a consequence, is rarely suspected of any violent or evil taint.

With so much socialism now taken for granted, we

are inclined to think that only other countries condone and practice strife and violence — not us.

Who, for instance, ever thinks of TVA as founded on strife and violence? Or social security, federal urban renewal, public housing, foreign aid, farm and all other subsidies, the Post Office, rent control, other wage and price controls, all space projects other than for strictly defensive purposes, compulsory unionism, production controls, tariffs and all other governmental protections against competition?

Who ponders the fact that every one of these aspects of state socialism is an exemplification of strife and violence and that such practices are multiplying rapidly?

The word "violence," as here used, refers to a particular kind of force. Customarily, the word is applied indiscriminately to two distinct kinds of force, each as different from the other as an olive branch differs from a gun.

One is defensive or repellent force. The other is initiated or aggressive force.

If someone were to initiate such an action as flying at you with a dagger, that would be an example of aggressive force. It is this kind of force I call strife or violence. The force you would employ to repel the violence I would call defensive force.

Try to think of a single instance where aggressive force — strife or violence — is morally warranted. There is none. Violence is morally insupportable!

Defensive force is never an initial action. It comes into play only secondarily, that is, as the antidote to aggressive force or violence. Any individual has a moral right to defend his life, the fruits of his labor (that which sustains his life), and his liberty — by demeanor, by persuasion or with a club if necessary. Defensive force is morally warranted.

Moral rights are exclusively the attributes of individuals. They inhere in no collective, governmental or otherwise. Thus, political officialdom, in sound theory, can have no rights of action which do not pre-exist as rights in the individuals who organize government.

To argue contrarily is to construct a theory no more tenable than the Divine Right of Kings. For, if the right to government action does not

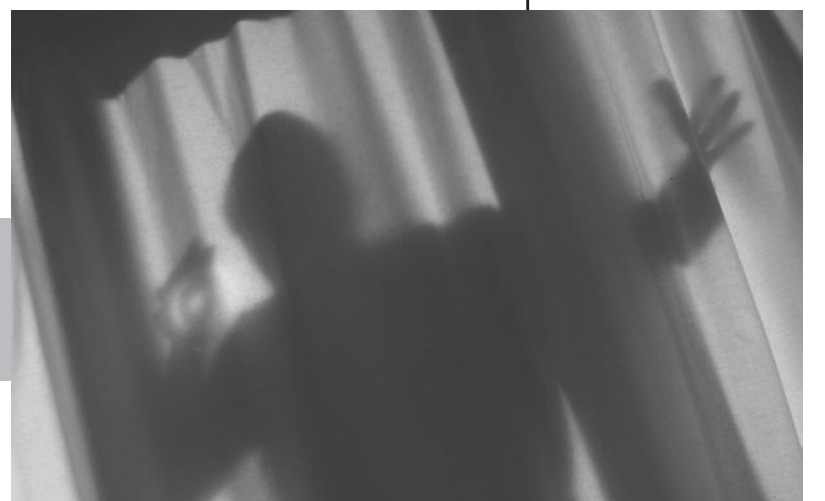

As the individual has the moral right to defend his life and property — a right common to all individuals, a universal right — he is within his rights to delegate this right of defense to a societal organization. We have here the logical prescription for government's limitation. It performs morally when it carries out the individual moral right of defense.



originate with the organizers of said government, from whence does it come?

As the individual has the moral right to defend his life and property — a right common to all individuals, a universal right — he is within his rights to delegate this right of defense to a societal organization. We have here the logical prescription for government's limitation. It performs morally when it carries out the individual moral right of defense.

As the individual has no moral right to use aggressive force against another or others — a moral limitation common to all individuals — it follows that he cannot delegate that which he does not possess. Thus, his societal organization — government — has no moral right to aggress against another or others. To do so would be to employ strife or violence.

To repeat a point, it is necessary to recognize that man's energies manifest themselves either destructively or creatively, peacefully or violently. It is the function of government to inhibit and to penalize the destructive or

violent manifestations of human energy.

It is a malfunction to inhibit, to penalize, to interfere in any way whatsoever with the peaceful or creative or productive manifestations of human energy. To do so is clearly to aggress, that is, to take violent action.

*The above essay is an excerpt from "Strife as a Way of Life," published in 1964 as a chapter in Leonard Read's classic book, "Anything That's Peaceful." Read was the founder of the Foundation for Economic Education, an organization that, to this day, espouses the philosophy of individual freedom and virtues of capitalism. Copyright Foundation for Economic Education. Reprinted with permission.*

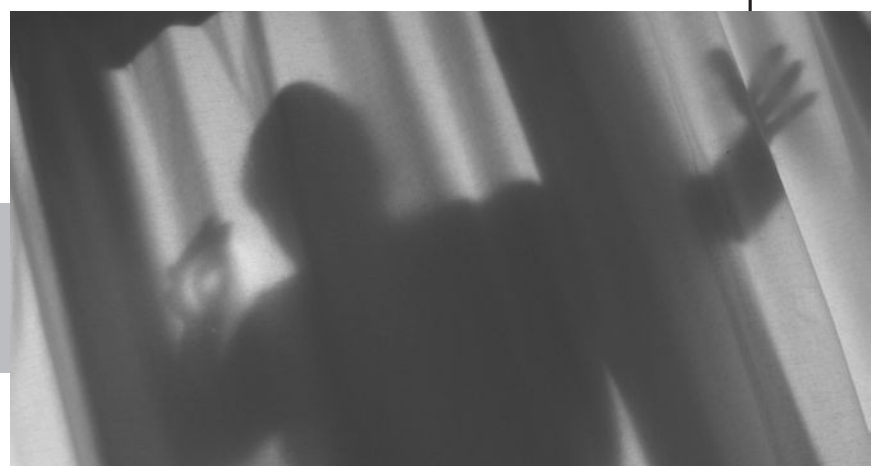

# WHAT SPENDING & DEFICITS DO

by Henry Hazlitt

Chronic excessive government spending and chronic huge deficits are twin evils. They stifle the growth and expansion of private-sector wealth. And that means fewer jobs.

The direct cause of inflation is the issuance of an excessive amount of paper money. The most frequent cause of the issuance of too much paper money is a government budget deficit.

The majority of economists have long recognized this, but the majority of politicians have studiously ignored it. One result, in this age of inflation, is that economists have tended to put too much emphasis on the evils of deficits as such and too little emphasis on the evils of excessive government spending, whether the budget is balanced or not.

So it is desirable to begin with the question: What is the effect of government spending on the economy — even if it is wholly covered by tax revenues?

The economic effect of government spending depends on what the spending is for, compared with what the private spending it displaces would be for. To the extent that the government uses its tax-raised money to provide more urgent services for the community than the taxpayers themselves otherwise would or could have provided, the government spending is beneficial to the community.

To the extent that the government provides policemen and judges to prevent or mitigate force, theft and fraud, it protects and encourages production and welfare. The same applies, up to a certain point, to what the government pays out to provide armies and armament against foreign aggression. It applies also to the provision by city governments of sidewalks, streets and sewers, and to the provision by states of roads, parkways and bridges.

But government expenditure even on necessary types of service may easily become excessive. Sometimes it may be difficult to measure exactly where the point of excess begins. It is to be hoped, for example, that armies and armament may never need to be used, but it does not follow that providing them is mere waste. They are a form of insurance premium; and in this world of nuclear warfare and incendiary slogans, it is not easy to say how big a premium is enough. The exigencies of politicians seeking re-election, of course, may very quickly lead to unneeded roads and other public works.

## Welfare spending

Waste in government spending in other directions can soon become flagrant. The money spent on various forms of relief, now called “social welfare,” is more responsible for the spending explosion of the U.S. gov-

ernment than any other type of outlay.

In the fiscal year 1927, when total expenditures of the federal government were \$2.9 billion, a negligible percentage of that amount went for so-called welfare. In fiscal 1977, when prospective total expenditures have risen to \$394.2 billion — 136 times as much — welfare spending alone (education, social services, Medicaid, Medicare, Social Security, veterans benefits, etc.) comes to \$205.3 billion, or more than half the total. The effect of this spending is on net balance to reduce production, because most of it taxes the productive to support the unproductive.

As to the effect of the taxes levied to pay for the spending, all taxation must discourage production to some extent, directly or indirectly. Either it puts a direct penalty on the earning of income, or it forces producers to raise their prices and so diminish their sales, or it discourages investment, or it reduces the savings available for investment; or it does all of these.

Some forms of taxation have more harmful effects on production than others. Perhaps the worst is heavy taxation of corporate earnings. This discourages business and output; it reduces the employment that the politicians profess to be their primary concern; and it prevents the capital formation that is so necessary to increase real productivity, real income, real wages, real welfare.

Almost as harmful to incentives and to capital formation is progressive personal income taxation. And the higher the level of taxation the greater the damage it does.

## Disruption of the economy

Let us consider this in more detail. The greater the amount of government spending, the more it depresses the economy.

In so far as it is a substitute for private spending, it does nothing to “stimulate” the economy. It merely directs labor and capital into the production of less necessary goods or services at the expense of more necessary goods or services.

It leads to malproduction.

It tends to direct funds out of profitable capital investment and into immediate consumption. And most “welfare” spending, to repeat, tends to support the unproductive at the expense of the productive.

But more importantly, the higher the level of government spending, the higher the



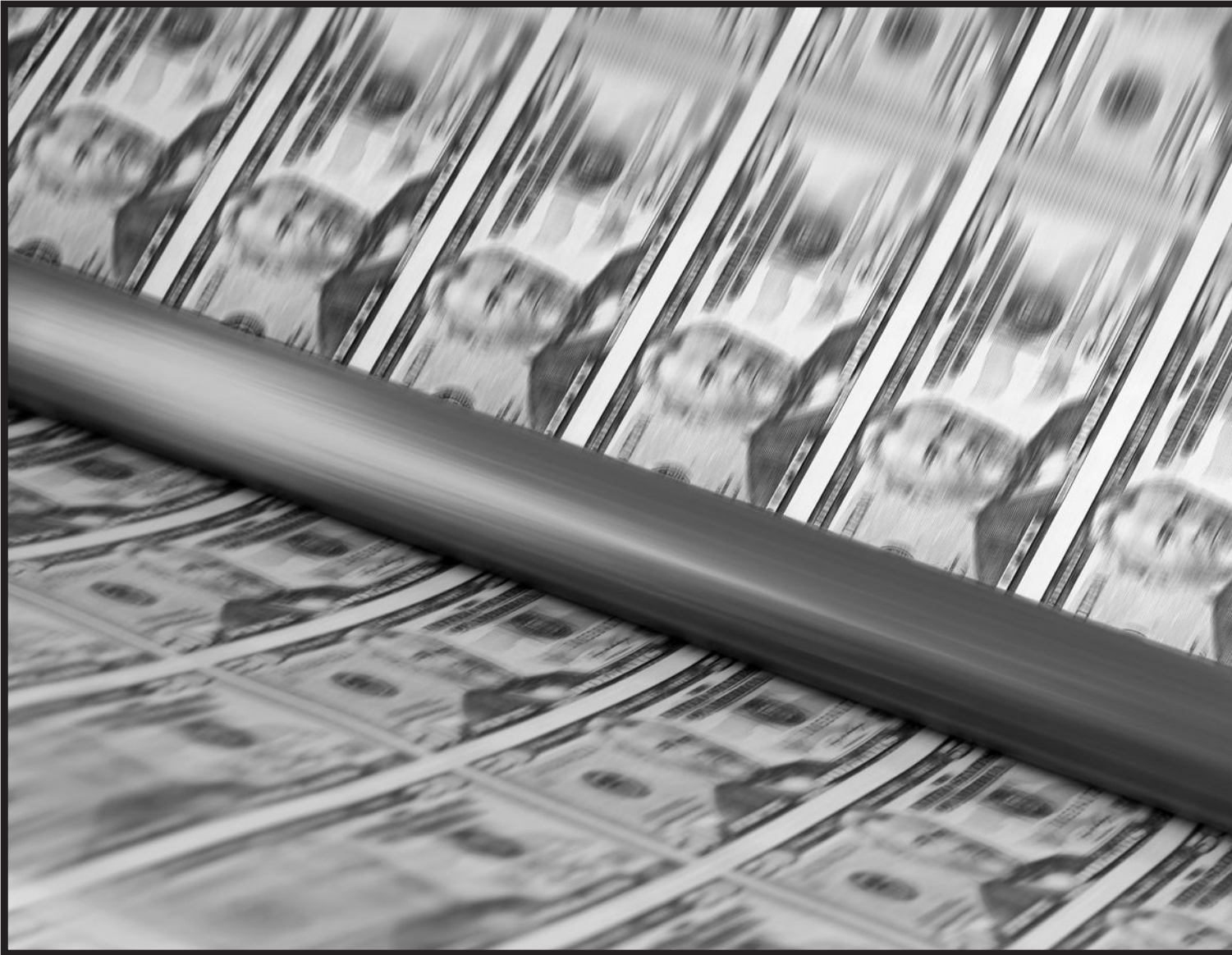

(Printing and distributing money) may be done either directly, or by the government's asking the Federal Reserve or the private commercial banks to buy its securities and to pay for them either by creating deposit credits or with newly issued inconvertible Federal Reserve notes. This of course is simple, naked inflation.

level of taxation. And the higher the level of taxation, the more it discourages, distorts and disrupts production. It does this much more than proportionately.

A 1% sales tax, personal income tax or corporation tax would do very little to discourage production, but a 50% rate can be seriously disruptive. Just as each additional fixed increment of income will tend to have a diminishing marginal value to the receiver, so each additional subtraction from his income will mean a more than proportional deprivation and disincentive.

The adjective "progressive" usually carries an approbatory connotation, but an income tax can appropriately be called "progressive" only in the sense that a disease can be called progressive. So far as its effect on incentives and production are concerned, such a tax is increasingly retrogressive or repressive.

#### **Total spending is key**

Though, broadly speaking, only a budget deficit tends to lead to inflation, the recognition of this truth has led to a serious underestimation of the harmfulness of an exorbitant level of total government spending.

While a budget balanced at a level of \$100 billion for both spending and tax revenues may be acceptable (at, say, 1977's level of national income and dollar purchasing power), a budget balanced at a level above \$400

billion may in the long run prove ruinous. In the same way, a deficit of \$50 billion at a \$400 billion level of spending is far more ominous than a deficit of the same amount at a spending level of \$200 billion. An exorbitant spending level, in sum, can be as great or a greater evil than a huge deficit. Everything depends on their relative size, and on their combined size compared with the national income.

Let us look first at the effect of a deficit as such. That effect will depend in large part on how the deficit is financed. Of course if, with a given level of spending, a deficit of, say, \$50 billion is then financed by added taxation, it ceases by definition to be a deficit. But it does not follow that this is the best course to take.

Whenever possible (except, say, in the midst of a major war) a deficit should be eliminated by reducing expenditures rather than by increasing taxes, because of the harm the still heavier taxes would probably do in discouraging and disorganizing production.

It is necessary to emphasize this point, because every so often some previous advocate of big spending suddenly turns "responsible," and solemnly tells conservatives that if they want to be equally responsible it is now their duty to "balance the budget" by raising taxes to cover the existing and planned expenditures.

Such advice completely begs the question. It tac-



itly assumes that the existing or planned level of expenditures, and all its constituent items, are absolutely necessary, and must be fully covered by increased taxes no matter what the cost in economic disruption.

We have had 39 deficits in the 47 fiscal years since 1931. The annual spending total has gone up from \$3.6 billion in 1931 to \$394.2 billion — 110 times as much — in 1977. Yet the argument that we must keep on balancing this multiplied spending by equally multiplied taxation continues to be regularly put forward. The only real solution is to start slashing the spending before it destroys the economy.

### Two Ways to Pay

Given a budget deficit, however, there are two ways in which it can be paid for. One is for the government to pay for its deficit outlays by printing and distributing more money.

This may be done either directly, or by the government's asking the Federal Reserve or the private commercial banks to buy its securities and to pay for them either by creating deposit credits or with newly issued inconvertible Federal Reserve notes. This of course is simple, naked inflation.

Or the deficit may be paid for by the government's selling its bonds to the public, and having them paid for out of real savings. This is not directly inflationary, but it merely leads to an evil of a different kind. The government borrowing competes with and "crowds out" private capital investment, and so retards economic growth.

Let us examine this a little more closely. There is at any given time a total amount of actual or potential savings available for investment. Government statistics regularly give estimates of these. The gross national product in 1974, for example, is given as \$1,499 billion. Gross private saving was \$215.2 billion — 14.4% of this — of which \$74 billion consisted of personal saving and \$141.6 billion of gross business saving. But the federal budget deficit in that year was \$11.7 billion, and in 1975 \$73.4 billion, seriously cutting down the amount that could go into the capital investment necessary to increase productivity, real wages and real long-run consumer welfare.

### Sources and uses of capital

The government statistics estimate the amount of gross private domestic investment in 1974 at \$215 billion and in 1975 at \$183.7 billion. But it is probable that the greater part of this represented mere replacement of deteriorated, worn-out or obsolete plant, equipment and housing, and that new capital formation was much smaller.

Let us turn to the amount of new capital supplied through the security markets. In 1973, total new issues of securities in the United States came to \$99 billion. Of these, \$32 billion consisted of private corporate stocks and bonds, \$22.7 billion of state and local bonds and notes, \$1.4 billion of bonds of foreign governments, and \$42.9 billion of obligations of the U.S. government or of its agencies. Thus of the combined total of \$74.9 billion borrowed by the U.S. government and by private industry, the government got 57%, and private industry only 43%.

The crowding-out argument can be stated in a few elementary propositions.

1. Government borrowing competes with private borrowing.
2. Government borrowing finances government deficits.
3. What the government borrows is spent chiefly on consumption, but what private industry borrows chiefly finances capital investment.
4. It is the amount of new capital investment that is chiefly responsible for the improvement of economic conditions.

The possible total of borrowing is restricted by the

amount of real savings available. Government borrowing crowds out private borrowing by driving up interest rates to levels at which private manufacturers who would otherwise have borrowed for capital investment are forced to drop out of the market.

### Why the Deficits?

Yet government spending and deficits keep on increasing year by year. Why? Chiefly because they serve the immediate interests of politicians seeking votes, but also because the public still for the most part accepts a set of sophisticated rationalizations.

The whole so-called Keynesian doctrine may be summed up as the contention that deficit spending, financed by borrowing, creates employment, and that enough of it can guarantee "full" employment.

The American people have even had foisted upon them the myth of a "full-employment budget." This is the contention that projected federal expenditures and revenues need not be, and ought not to be, those that would bring a real balance of the budget under actually

Though, broadly speaking, only a budget deficit tends to lead to inflation, the recognition of this truth has led to a serious underestimation of the harmfulness of an exorbitant level of total government spending.

existing conditions, but merely those that would balance the budget if there were "full employment."

To quote a more technical explanation (as it appears, for example, in the Economic Report of the President of January, 1976): "Full employment surpluses or deficits are the differences between what receipts and expenditures are estimated to be if the economy were operating at the potential output level consistent with a 4% unemployment" (p. 54).

A table in that report shows what the differences would have been for the years 1969 to 1975, inclusive, between the actual budget and the so-called full-employment budget. For the calendar year 1975, for example, actual receipts were \$283.5 billion and expenditures \$356.9 billion, leaving an actual budget deficit of \$73.4 billion.

But in conditions of full employment, receipts from the same tax rates might have risen to \$340.8 billion, and expenditures might have fallen to \$348.3 billion, leaving a deficit not of \$73.4 billion but only of \$7.5 billion. Nothing to worry about.

### Priming the pump

Nothing to worry about, perhaps, in a dream world.

But let us return to the world of reality. The implication of the full-employment budget philosophy (though it is seldom stated explicitly) is not only that in a time of high unemployment it would make conditions even worse to aim at a real balance of the budget, but that a full-employment budget can be counted on to bring full employment.

The proposition is nonsense. The argument for it assumes that the amount of employment or unemployment depends on the amount of added dollar "purchasing power" that the government decides to squirt into the economy. Actually the amount of unemployment is chiefly





Government borrowing crowds out private borrowing by driving up interest rates to levels at which private manufacturers who would otherwise have borrowed for capital investment are forced to drop out of the market. Yet government spending and deficits keep on increasing year by year. Why? Chiefly because they serve the immediate interests of politicians seeking votes ...

determined by entirely different factors — by the relations in various industries between selling prices and costs; between particular prices and particular wage-rates; by the wage-rates exacted by strong unions and strike threats; by the level and duration of unemployment insurance and relief payments (making idleness more tolerable or attractive); by the existence and height of legal minimum-wage rates; and so on.

But all these factors are persistently ignored by the full-employment budgeteers and by all the other advocates of deficit spending as the great panacea for unemployment.

#### One-way formula

It may be worthwhile, before we leave this subject, to point to one or two of the practical consequences of a consistent adherence to a full employment-budget policy.

In the 28 years from 1948 to 1975 inclusive, there were only eight in which unemployment fell below the government target-level of 4%. In all the other years, the full-employment-budgeteers (perhaps we should call them the “fulembudgers” for short) would have prescribed an actual deficit. But they say nothing about achieving a surplus in the full-employment years, much less about its desirable size. Presumably they would consider any surplus at all, any repayment of the government debt, as extremely dangerous at any time.

So a prescription for full-employment budgeting might not produce very different results in practice from a prescription for perpetual deficit.

Perhaps an even worse consequence is that as long as this prescription prevails, it can only act to divert attention from the real causes of unemployment and their real cure...

#### The Phillips Curve

A myth even more pernicious than the full-employment budget, and akin to it in nature, is the Phillips Curve. This is the doctrine that there is a “trade-off” between employment and inflation, and that this can be plotted on a precise curve — that the less inflation, the more unemployment, and the more inflation the less unemployment.

But this incredible doctrine is more directly related to currency issue than to government spending and deficits and can best be examined elsewhere.

In conclusion: Chronic excessive government spending and chronic huge deficits are twin evils. The deficits lead more directly to inflation, and therefore in recent years they have tended to receive a disproportionate amount of criticism from economists and editorial writers.

But the total spending is the greater evil, because it is the chief political cause of the deficits. If the spending were more moderate, the taxes to pay for it would not have to be so oppressive, so damaging to incentive, so destructive of employment and production.

So the persistence and size of deficits, though serious, is a derivative problem; the primary evil is the exorbitant spending, the Leviathan “welfare” state. If the spending were brought within reasonable bounds, the taxes to pay for it would not have to be so burdensome and demoralizing, and politicians could be counted on to keep the budget balanced.

*Henry Hazlitt wrote this essay for the Foundation for Economic Education in 1977. Copyright Foundation for Economic Education (fee.org). Reprinted with permission.*



# THE 'BAD' PEOPLE BEHIND INFLATION

By Ludwig von Mises

When prices rise, politicians say the profiteers must be stopped. But the politicians never accept that they, and only they, are responsible for inflation.

I assume that you know how the banking system developed and how the banks could improve the services tendered by gold by transferring assets from one individual to another individual in the books of the banks.

When you study the development of the history of money, you will discover that there were countries in which there were systems in which all the payments were made by transactions in the books of a bank, or of several banks.

The individuals acquired an account by paying gold into this bank. There is a limited quantity of gold, so the payments that are made are limited. And it was possible to transfer gold from the account of one man to the account of another.

But then the governments began something which I can only describe in general words. The governments began to issue paper which they wanted to serve the role, perform the service, of money. When people bought something, they expected to receive from their bank a certain quantity of gold to pay for it.

But the government asked: What's the difference whether the people really get gold or whether they get a title from the bank that gives them the right to ask for gold? It will be all the same to them.

So the government issued paper notes, or gave the bank the privilege to issue paper notes, which gave the receiver the right to ask for gold. This led to an increase in the number of paper banknotes, which gave to the bearer the right to ask for gold.

Not too long ago, our government proclaimed a new method for making everybody prosperous: a method called "deficit financing."

Now that is a wonderful word. You know, technical terms have the bad habit of not being understood by people. The government and the journalists who were writing for the government told us about this "deficit spending."

It was wonderful! It was considered something that would improve conditions in the whole country. But if you translate this into more common language, the language of the uneducated, then you say "printed money."

The government says this is only due to your lack of education; if you had an education, you wouldn't say "printed money"; you would call it "deficit financing" or "deficit spending."

Now what does this mean? Deficits! This means that the government spends more than it collects in taxes

and in borrowing from the people; it means government spending for all those purposes for which the government wants to spend. This means inflation, pushing more money into the market; it doesn't matter for what purpose.

And that means reducing the purchasing power of each monetary unit. Instead of collecting the money that the government wanted to spend, the government fabricated the money.

Printing money is the easiest thing. Every government is clever enough to do it. If the government wants to pay out more money than before, if it wants to buy more commodities for some purpose or to raise the salaries of government employees, no other way is open to it under normal conditions than to collect more taxes and use this increased income to pay, for instance, for the higher wages of its employees.

The fact that people have to pay higher taxes so that the government may pay higher wages to its employees means that individual taxpayers are forced to restrict their expenditures. This restriction of purchases on the part of the taxpayers counteracts the expansion of purchases by those receiving the money collected by the government. Thus, this simple contraction of spending on the part of some — the taxpayers from whom money is taken to give to others — does not bring about a general change in prices.

The thing is that the individual cannot do anything that makes the inflationary machine and mechanism work. This is done by the government.

The government makes the inflation. And if the government complains about the fact that prices are going up and appoints committees of learned men to fight against the inflation, we have only to say: "Nobody other than you, the government, brings about inflation, you know."

On the other hand, if the government does not raise taxes, does not increase its normal revenues, but prints an additional quantity of money and distributes it to government employees, additional buyers appear on the market. The number of buyers is increased as a result, while the quantity of goods offered for sale remains the same. Prices necessarily go up because there are more people with more money asking for commodities which had not increased in supply.

The government does not speak of the increase in the quantity of money as "inflation;" it calls the fact that commodity prices are going up "infla-





The government does not speak of the increase in the quantity of money as 'inflation;' it calls the fact that commodity prices are going up 'inflation.' But the individual cannot do anything that makes the inflationary machine work. This is done by the government.

tion." The government then asks who is responsible for this "inflation," that is for the higher prices? The answer — "bad" people; they may not know why prices are going up, but nevertheless they are sinning by asking for higher prices.

The best proof that inflation — the increase in the quantity of money — is very bad is the fact that those who are making the inflation are denying again and again, with the greatest fervor, that they are responsible.

"Inflation?" they ask. "Oh! This is what you are doing because you are asking higher prices. We don't know

why prices are going up. There are bad people who are making the prices go up. But not the government!"

And the government says: "Higher prices? Look, these people, this corporation, this bad man, the president of this corporation, ..." Even if the government blames the unions — I don't want to talk about the unions — but even then we have to realize what the unions cannot do is to increase the quantity of money. And, therefore, all the activities of the unions are within the framework that is built by the government in influencing the quantity of money.

The situation, the political situation, the discussion of the problem of inflation, would be very different if the people who are making the inflation, the government, were openly saying, "Yes, we do it. We are making the inflation. Unfortunately, we have to spend more than people are prepared to pay in taxes."

But they don't say this. They do not even say openly to everybody, "We have increased the quantity of money. We are increasing the quantity of money because we are spending more, more than you are paying us." And this leads us to a problem which is purely political.

Those into whose pockets the additional money goes first profit from the situation, whereas others are compelled to restrict their expenditures.

The government does not acknowledge this; it does not say, "We have increased the quantity of money and, therefore, prices are going up." The government starts by saying, "Prices are going up. Why? Because people are bad. It is the duty of the government to prevent bad people from bringing about this upward movement of prices, this inflation. Who can do this? The government!"

Then the government says: "We will prevent profiteering, and all these things. These people, the profiteers are the ones who are making inflation; they are asking higher prices." And the government elaborates "guidelines" for those who do not wish to be in wrong with the government. Then, it adds that this is due to "inflationary pressures."

They have invented many other terms also which I cannot remember, such silly terms, to describe this situation — "cost-push inflation," "inflationary pressures," and the like. Nobody knows what an "inflationary pressure" is; it has never been defined. What is clear is what inflation is.

Inflation is a considerable addition to the quantity of money in circulation. This upward movement of prices due to the inflation, due to the fact that the system was inflated by additional quantities of money, brings the prices up. And this system can work for some time, but only if there is some power that restricts the government's wish to expand the quantity of money and is powerful enough to succeed to some extent in this regard.

The evils which the government, its helpers, its committees and so on, acknowledge are connected with this inflation. but not in the way in which they are discussed. This shows that the intention of the governments and of its propagators (propagandizers promoters) is to conceal the real cause of what is happening.

If we want to have a money that is acceptable on the market as the medium of exchange, it must be something that cannot be increased with a profit by anybody, whether government or a citizen. The worst failures of money, the worst things done to money were not done by criminals but by governments, which very often ought to be considered, by and large, as ignoramuses but not as criminals.

*The above article is from "Ludwig von Mises on Money & Inflation, a Synthesis of Several Lectures," compiled by Bettina Bien Greaves. Ms. Greaves attended von Mises' lectures in the 1960s at the Foundation for Economic Education. Copyright Foundation for Economic Education. Reprinted with permission.*



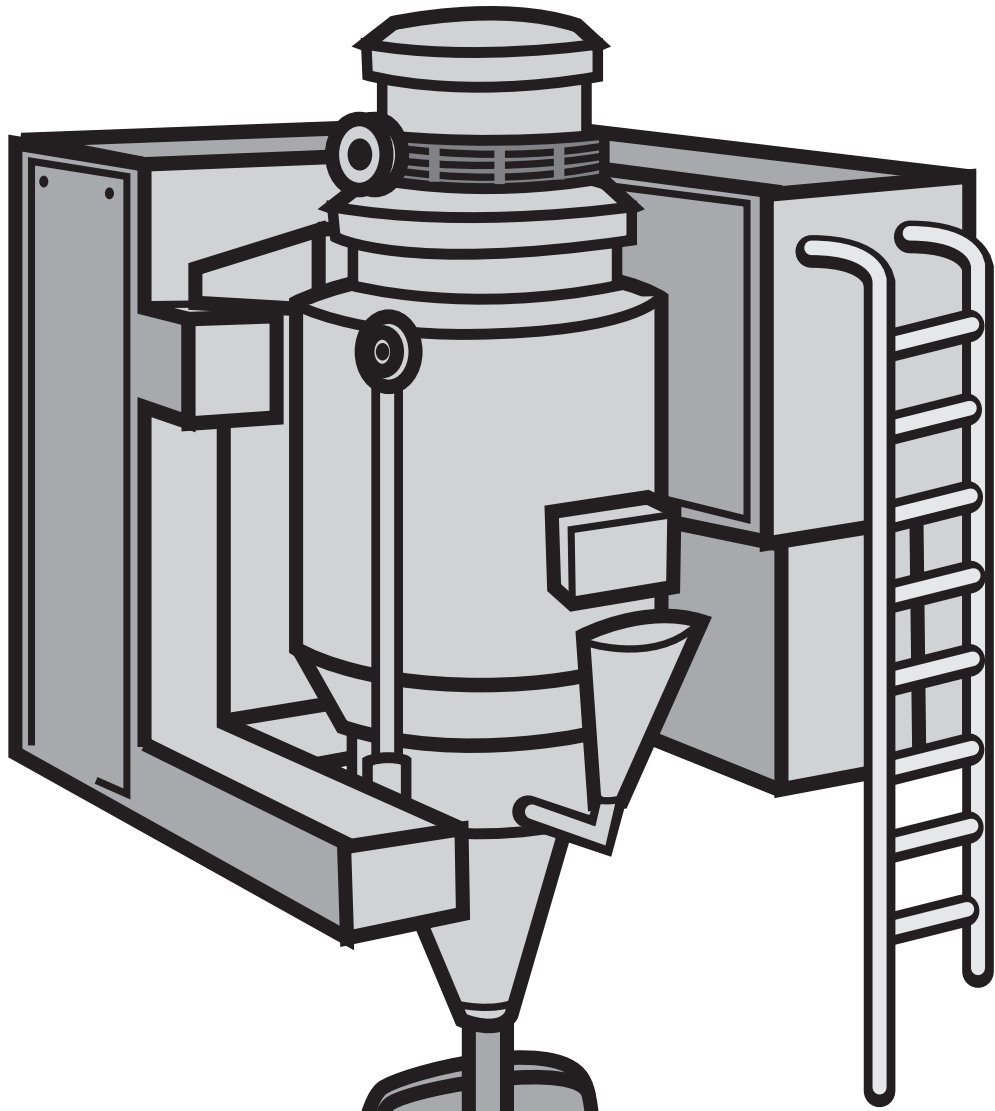

# TOM SMITH AND HIS INCREDIBLE BREAD MACHINE

**By R.W. Grant**

Illustrations by Austin McKinley

This is the legend of a man whose name  
Was a household word: a man whose fame  
Burst on the world like an atom bomb.  
Smith was his last name; first name: Tom.

The argument goes on today.  
"He was a villain," some will say.  
"No! A hero!" others declare.  
Or was he both? Well, I despair;  
The fight will last 'til kingdom come;  
Was Smith a hero? Or was Smith a bum?  
So, listen to the story and it's up to you  
To decide for yourself as to which is true!

Now, Smith, an inventor, had specialized  
In toys. So people were surprised  
When they found that he instead  
Of making toys, was baking bread!  
The news was flashed by CBS  
Of his incredible success.  
Then NBC jumped in in force,  
Followed by the Times, of course.  
The reason for their rapt attention,  
The nature of his new invention,  
The way to make bread he'd conceived  
Cost less than people could believe!  
And not just make it! This device  
Could in addition wrap and slice!  
The price per loaf, one loaf or many:  
The miniscule sum of under one penny!

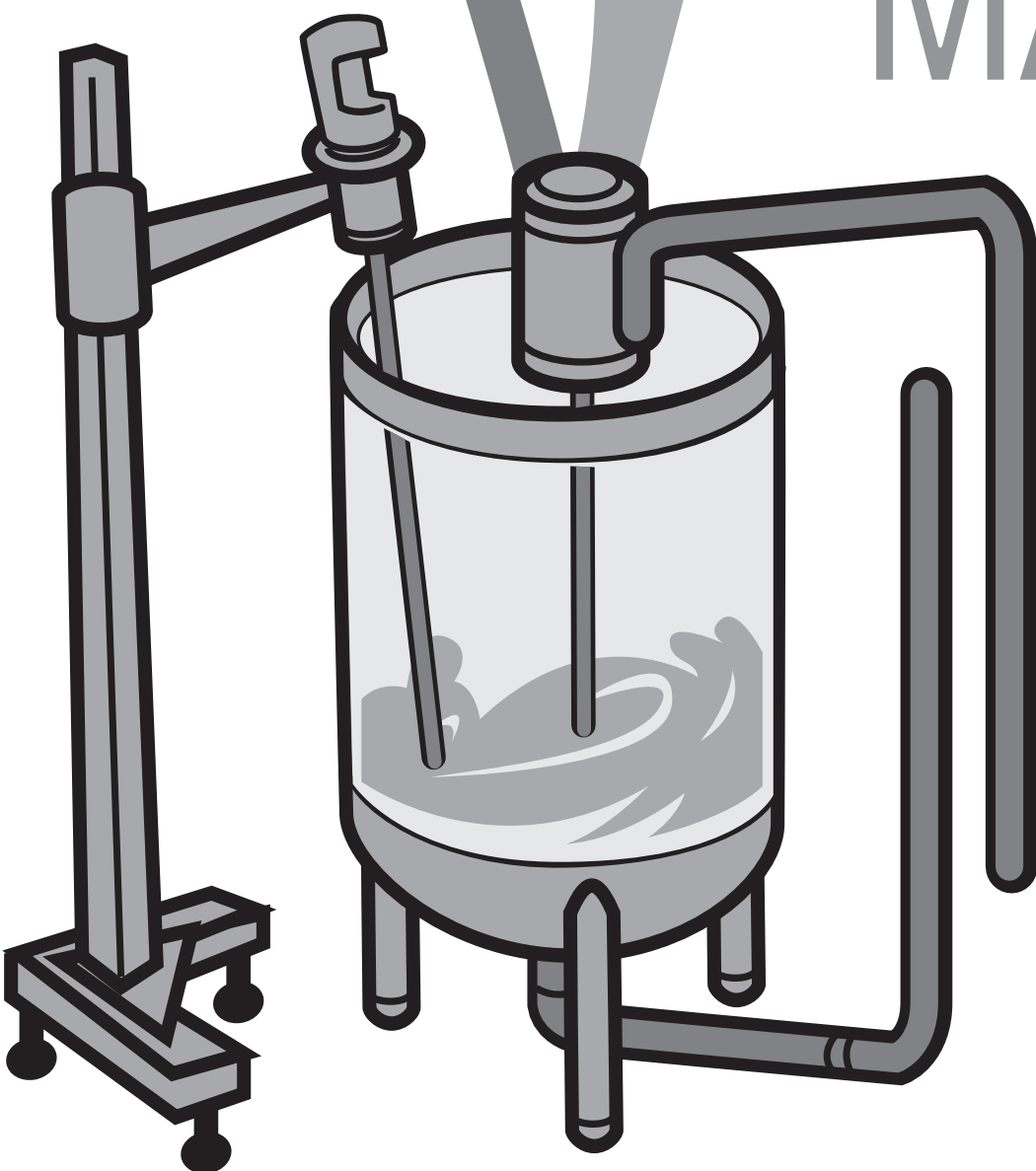

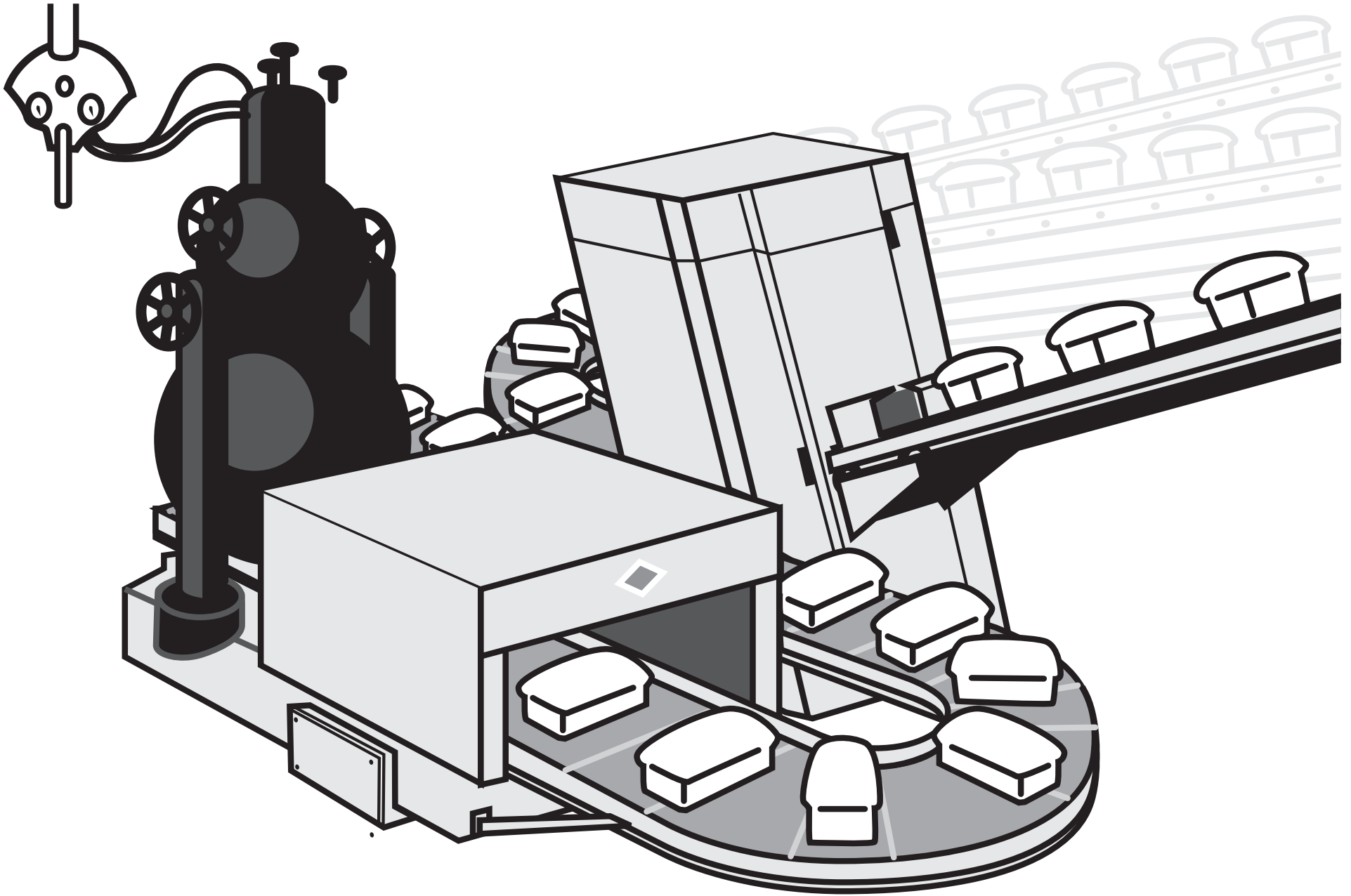

Can you imagine what this meant?  
Can you comprehend the consequent?  
The first time yet the world well fed!  
And all because of Tom Smith's bread!

Not the last to see the repercussions  
Were the Red Chinese, and, of course, the  
Russians,  
For Capitalist bread in such array

Threw the whole red block into black dis-  
may!  
Nonetheless, the world soon found  
That bread was plentiful the world  
around.  
Thanks to Smith and all that bread,  
A grateful world was at last well fed!

But isn't it a wondrous thing  
How quickly fame is flown?  
Smith, the hero of today  
Tomorrow, scarcely known!  
Yes, the fickle years passed by.  
Smith was a billionaire.

But Smith himself was now forgot,  
Though bread was everywhere.  
People, asked from where it came,  
Would very seldom know.

They would simply eat and ask,  
'Was not it always so?'

However, Smith cared not a bit,  
For millions ate his bread,  
And "Everything is fine," thought he.  
'I'm rich and they are fed!'

Everything was fine, he thought?  
He reckoned not with fate.  
Note the sequence of events  
Starting on the date  
On which inflation took its toll,  
And to a slight extent,  
The price on every loaf increased:  
It went to one full cent!

A sharp reaction quickly came.  
People were concerned.  
White House aide expressed dismay.  
Then the nation learned  
That Russia lodged a sharp protest.  
India did the same.  
"Exploitation of the Poor!"  
Yet, who was there to blame?

And though the clamor ebbed and flowed,  
All that Tom would say  
Was that it was but foolish talk.  
Which soon would die away.  
And it appeared that he was right.  
Though on and on it ran,  
The argument went 'round and 'round  
But stopped where it began.

There it stopped, and people cried,  
"For heaven's sake, we can't decide!  
It's relative! Beyond dispute,  
There's no such thing as 'absolute'!  
And though we try with all our might,  
Since nothing's ever black or white,  
All that we can finally say is  
'Everything one shade of grey is!'  
So people cried out, "Give us light!  
We can't tell what's wrong from right!"

To comprehend confusion,  
We seek wisdom at its source.  
To whom, then did the people turn?  
The Intellectuals, of course!

And what could be a better time  
For them to take the lead,  
Than at their International Conference  
On Inhumanity and Greed.  
For at this weighty conference,  
Once each year we face  
The moral conscience of the world—  
Concentrated in one place.

At that mighty conference were  
A thousand, more or less,  
Of intellectuals and bureaucrats,  
And those who write the press.  
And from Yale and Harvard  
The professors; all aware  
The fate of Smith would now be known.  
Excitement filled the air!

"The time has come," the chairman said  
"To speak of many things:  
Of duty, bread and selfishness,  
And the evil that it brings.  
For, speaking thus we can amend  
That irony of fate  
That gives to unenlightened minds  
The power to create.



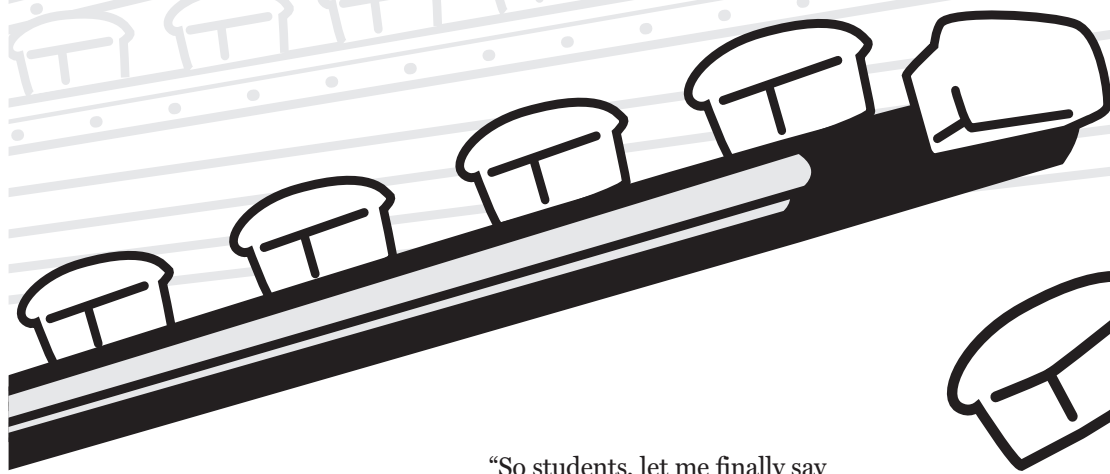

“Since reason tells us that it can’t,  
Therefore let us start  
Not by thinking with the mind,  
But only with the heart!  
Since we believe in people, then,”  
At last the chairman said,  
“We must meet our obligation  
To see that they are fed!”

And so it went, one by one,  
Denouncing private greed;  
Denouncing those who’d profit thus  
From other people’s need!

Then, suddenly each breath was held,  
For there was none more wise  
Than the nation’s foremost Pundit  
Who now rose to summarize:

“My friends,” he said, (they all  
exhaled)  
“We see in these events  
The flouting of the Higher Law—  
And its consequence.  
We must again remind ourselves  
Just why mankind is cursed:  
Because we fail to realize  
Society comes first!”

“Smith placed himself above the  
group  
To profit from his brothers.  
He failed to see the Greater Good,  
Is Service, friends, to Others!”

With boldness and with vision,  
then,  
They ratified the motion  
To dedicate to all mankind  
Smith’s bread—and their devotion!

The conference finally ended.  
It had been a huge success.  
The intellectuals had spoken.  
Now others did the rest.

The professors joined in all the  
fuss,  
And one was heard to lecture thus:  
(For clarity, he spoke in terms  
Of Mother Nature, birds and worms):

“That early birds should get the worm  
Is clearly quite unfair.  
Wouldn’t it much nicer be  
If all of them would share?  
But selfishness and private greed

Seem part of nature’s plan,  
Which Mother Nature has decreed  
For bird. But also Man?  
The system which I question now,  
As you are well aware,  
(I’m sure you’ve heard the term  
before  
Is Business, Laissez-Faire!

“So students, let me finally say  
That we must find a nobler way.  
So, let us fix the race that all  
May finish side-by-side;  
The playing field forever flat,  
The score forever tied.  
To achieve this end, of course,  
We turn to government—and force.  
So, if we have to bring Smith do  
As indeed we should,  
I’m sure you will agree with me,  
It’s for the Greater Good!”

Comments in the nation’s press  
Now scorned Smith and his plunder:  
“What right had he to get so rich  
On other people’s hunger?”  
A prize cartoon depicted Smith  
With fat and drooping jowls  
Snatching bread from hungry babes,  
Indifferent to their howls.

One night, a TV star cried out,  
“Forgive me if I stumble,  
But I don’t think, I kid you not,  
That Smith is very humble!”  
Growing bolder, he leaped up,

(Silencing the cheers)  
“Humility!” he cried to all—  
And then collapsed in tears!

The clamor rises all about;  
Now hear the politician shout:  
“What’s Smith done, so rich to be?  
Why should Smith have more than thee?  
So, down with Smith and all his greed;  
I’ll protect your right to need!”

Then Tom found to his dismay  
That certain businessmen would say,  
“The people now should realize  
It’s time to cut Smith down to size,  
For he’s betrayed his public trust  
(And taken all that bread from us!)”

Well, since the Public does come first,  
It could not be denied  
That in matters such as this,  
The public must decide.  
So, SEC became concerned,  
And told the press what it had learned:  
“It’s obvious that he’s guilty  
—Of what we’re not aware—  
Though actually and factually  
We’re sure there’s something there!”

And Antitrust now took a hand.  
Of course it was appalled  
At what it found was going on.  
The “bread trust” it was called.

“Smith has too much crust,”  
they said. “A deplorable condition  
That Robber Barons profit thus  
From cutthroat competition!”

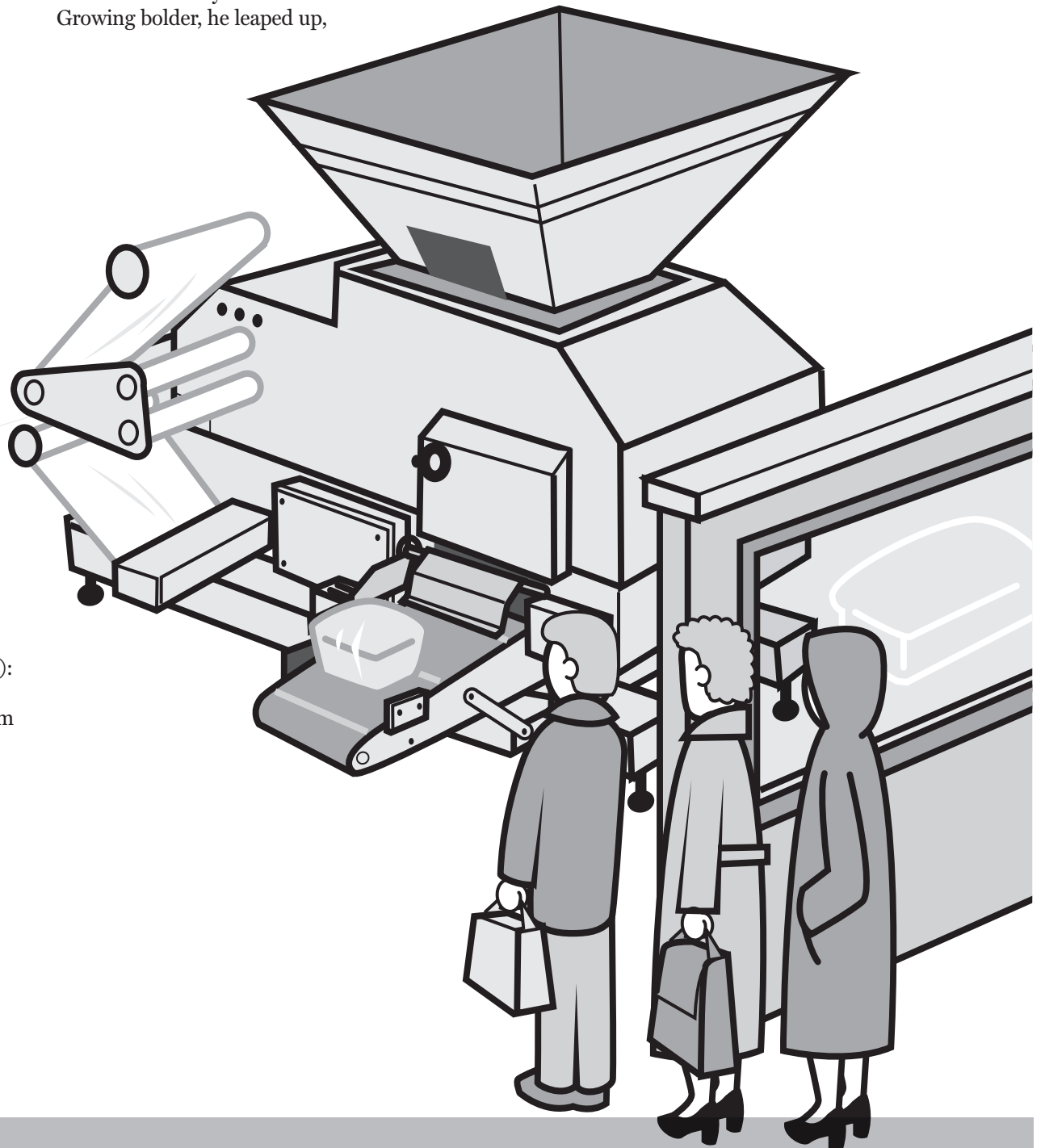

WELL!

This was getting serious!  
So Smith felt that he must  
Have a friendly interview  
With SEC and 'Trust.  
So, hat in hand, he went to them.  
They'd surely been misled;  
No rule of law had he defied.  
But then their lawyer said:

"The rule of law, in complex times,  
Has proved itself deficient.  
We much prefer the rule of men.  
It's vastly more efficient.

"So, nutshell-wise, the way it is,  
The law is what we say it is!

"So, let me state the present rules,"  
The lawyer then went on,  
"These very simple guidelines  
You can rely upon:  
You're gouging on your prices  
If you charge more than the rest.  
But it's unfair competition  
If you think you can charge less!  
"A second point that we would make,  
To help avoid confusion:  
Don't try to charge the same amount,  
For that would be collusion!

"You must compete—but not too much.  
For if you do, you see,  
Then the market would be yours—  
And that's monopoly!  
Oh, don't dare monopolize!  
We'd raise an awful fuss,  
For that's the greatest crime of all!  
(Unless it's done by us!)"

"I think I understand," said Tom.  
"And yet, before I go,  
How does one get a job like yours?  
I'd really like to know!"

The lawyer rose then with a smile;  
"I'm glad you asked," said he.  
"I'll tell you how I got my start  
And how it came to be."

(His secretaries gathered 'round  
As their boss did thus expound.)

*"When I was a lad going off to school,  
I was always guided by this golden rule:  
Let others take the lead in things, for  
heaven's sake,  
So if things go wrong-why, then it's their  
mistake!"*  
(*So if things go wrong-why, then it's their  
mistake!*)

*"Following this precept it came to pass  
I became the president of my senior class.  
Then on to college where my profs extolled  
The very same theory from the very same  
mold!"*  
(*The very same theory from the very same  
mold!*)

*"Let others take the chances, and I would  
go along.  
Then I would let them know where they all  
went wrong!  
So successful was my system that then  
indeed,  
I was voted most likely in my class to suc-  
ceed!"*

*(He was voted most likely in his class to  
succeed!)*

*"Then out into the world I went, along  
with all the rest,  
Where I put my golden rule to the ulti-  
mate test.  
I avoided all of commerce at whatever the  
cost—  
And because I never ventured, then I also  
never lost!"*  
(*And because he never ventured, then he  
also never lost!*)

*'With this unblemished record then, I  
quickly caught the eye  
Of some influential people 'mongst the  
powers on high.*

*And so these many years among the  
mighty I have sat,  
Having found my niche as a bureaucrat!"*  
(*Having found his niche as a bureaucrat*)

*"To be a merchant prince has never been  
my goal,  
For I'm qualified to play a more impor-  
tant role:  
Since I've never failed in business, this of  
course assures  
That I'm qualified beyond dispute to now  
run yours!"*  
(*That he's qualified beyond dispute to now  
run yours!*)

"Thanks; that clears it up," said Tom.

The lawyer said, "I'm glad!  
We try to serve the public good.  
We're really not so bad!

"Now, in disposing of this case,  
If you wish to know just how,  
Go up to the seventh floor;  
We're finalizing now!"

So, Tom went to the conference room  
Up on the seventh floor.  
He raised his hand, about to knock,  
He raised it—but no more—  
For what he overheard within  
Kept him outside the door!  
A sentence here, a sentence there—  
Every other word—  
He couldn't make it out (he hoped),  
For this is what he heard:

"Mumble, mumble, let's not fumble!  
Mumble, mumble, what's the charge?  
Grumble, grumble, he's not humble?  
Private greed? Or good of all?"

"Public Interest, Rah! Rah! Rah!  
Business, Business, Bah! Bah! Bah!

"Say, now this now we confess  
That now this now is a mess!  
Well now, what now do we guess?  
Discharge? Which charge would be best?"

"How 'bout 'Greed and Selfishness'?  
Oh, wouldn't that be fun?  
It's vague enough to trip him up  
No matter what he's done!

"We don't produce or build a thing!  
But before we're through,  
We allow that now we'll show Smith how  
We handle those who do!

"We serve the public interest;  
We make up our own laws;  
Oh, golly gee, how selflessly  
We serve the public cause!

"For we're the ones who make the rules  
At 'Trust and SEC,  
So bye and bye we'll get that guy;  
Now, what charge will it be?"

"Price too high? Or price too low?  
Now, which charge will we make?  
Well, we're not loath to charging both  
When public good's at stake!

"But can we go one better?  
How 'bout monopoly?  
No muss, no fuss, oh clever us!  
Right-O! Let's charge all three!"

"But why stop here? We have one more!  
Insider Trading! Number four!  
We've not troubled to define  
This crime in any way so,  
This allows the courts to find  
Him guilty 'cause we say so!"

So, that was the indictment.  
Smith's trial soon began.  
It was a cause célèbre  
Which was followed' cross the land.  
In his defense Tom only said,  
"I'm rich, but all of you are fed!  
Is that bargain so unjust  
That I should now be punished thus?"

Tom fought it hard all the way.  
But it didn't help him win.  
The jury took but half an hour  
To bring this verdict in:

"Guilty! Guilty! We agree!  
He's guilty of this plunder!  
He had no right to get so rich  
On other people's hunger!"

"Five years in jail!" the judge then said.  
"You're lucky it's not worse!  
Robber Barons must be taught  
Society Comes First!  
As flies to wanton boys," he leered,  
"Are we to men like these!  
They exploit us for their sport!  
Exploit us as they please!"

The sentence seemed a bit severe,  
But mercy was extended.  
In deference to his mother's pleas,  
One year was suspended.  
And what about the Bread Machine?  
Tom Smith's little friend?  
Broken up and sold for scrap.  
Some win. Some lose. The end.

## EPILOGUE

Now, bread is baked by government.  
And as might be expected,  
Everything is well controlled—  
The public well protected.

True, loaves cost ten dollars each.  
But our leaders do their best.  
The selling price is half a cent.  
Taxes pay the rest!



# MAN'S RIGHTS

By Ayn Rand

A special reprinting  
of a classic essay  
on freedom.

'There is only one fundamental right ... a man's right to his own life.' When the United States began, its founders were the only ones in history to recognize man as an end in himself, not as a sacrificial means to the ends of 'society.'

If one wishes to advocate a free society — that is, capitalism — one must realize that its indispensable foundation is the principle of individual rights.

If one wishes to uphold individual rights, one must realize that capitalism is the only system that can uphold and protect them. And if one wishes to gauge the relationship of freedom to the goals of today's intellectuals, one may gauge it by the fact that the concept of individual rights is evaded, distorted, perverted and seldom discussed, most conspicuously seldom by the so-called "conservatives."

"Rights" are a moral concept — the concept that provides a logical transition from the principles guiding an individual's actions to the principles guiding his relationship with others — the concept that preserves and protects individual morality in a social context — the link between the moral code of a man and the legal code of a society, between ethics and politics. Individual rights are the means of subordinating society to moral law.

Every political system is based on some code of ethics. The dominant ethics of mankind's history were variants of the altruist-collectivist doctrine, which subordinated the individual to some higher authority, either mystical or social. Consequently, most political systems were variants of the same statist tyranny, differing only in degree, not in basic principle, limited only by the accidents of tradition, of chaos, of bloody strife and periodic collapse.

Under all such systems, morality was a code applicable to the individual, but not to society. Society was placed outside the moral law, as its embodiment or source or exclusive interpreter — and the inculcation of self-sacrificial devotion to social duty was regarded as the main purpose of ethics in man's earthly existence.

Since there is no such entity as "society," since society is only a number of individual men, this meant, in practice, that the rulers of society were exempt from moral law; subject only to traditional rituals, they held total power and exacted blind obedience — on the implicit principle of: "The good is that which is good for society (or for the tribe, the race, the nation), and the ruler's edicts are its voice on earth."

This was true of all statist systems, under all variants of the altruist-collectivist ethics, mystical or social. "The Divine Right of Kings" summarizes the political theory of the first — "Vox populi, vox dei" of the second. As witness: The theocracy of Egypt, with the Pharaoh as an embodied god — the unlimited majority rule or democracy of Athens — the welfare state run by the Emperors of Rome — the Inquisition of the

late Middle Ages — the absolute monarchy of France — the welfare state of Bismarck's Prussia — the gas chambers of Nazi Germany — the slaughterhouse of the Soviet Union .

All these political systems were expressions of the altruist-collectivist ethics — and their common characteristic is the fact that society stood above the moral law; as an omnipotent, sovereign whim worshiper. Thus, politically, all these systems were variants of an amoral society.

The most profoundly revolutionary achievement of the United States of America was the subordination of society to moral law.

The principle of man's individual rights represented the extension of morality into the social system — as a limitation on the power of the state, as man's protection against the brute force of the collective, as the subordination of might to right. The United States was the first moral society in history.

All previous systems had regarded man as a sacrificial means to the ends of others, and society as an end in itself. The United States regarded man as an end in himself, and society as a means to the peaceful, orderly, voluntary coexistence of individuals. All previous systems had held that man's life belongs to society, that society can dispose of him in any way it pleases, and that any freedom he enjoys is his only by favor, by the permission of society, which may be revoked at any time.

## Society has no rights

The United States held that man's life is his by right (which means: by moral principle and by his nature), that a right is the property of an individual, that society as such has no rights, and that the only moral purpose of a government is the protection of individual rights.

A "right" is a moral principle defining and sanctioning a man's freedom of action in a social context. There is only one fundamental right (all the others are its consequences or corollaries): a man's right to his own life. Life is a process of self-sustaining and self-generated action; the right to life means the right to engage in self-sustaining and self-generated action — which means: the freedom to take all the actions required by the nature of a rational being for the support, the furtherance, the fulfillment and the enjoyment of his own life. (Such is the meaning of the right to life, liberty, and the pursuit of happiness.)

The concept of a "right" pertains only to action specifically, to freedom of action. It means freedom from physical compulsion, coercion or inter-



ference by other men.

Thus, for every individual, a right is the moral sanction of a positive — of his freedom to act on his own judgment, for his own goals, by his own voluntary, uncoerced choice. As to his neighbors, his rights impose no obligations on them except of a negative kind: to abstain from violating his rights.

The right to life is the source of all rights — and the right to property is their only implementation. Without property rights, no other rights are possible. Since man has to sustain his life by his own effort, the man who has no right to the product of his effort has no means to sustain his life. The man who produces while others dispose of his product is a slave.

Bear in mind that the right to property is a right to action, like all the others: It is not the right to an object, but to the action and the consequences of producing or earning that object. It is not a guarantee that a man will earn any property, but only a guarantee that he will own it if he earns it. It is the right to gain, to keep, to use and to dispose of material values.

The concept of individual rights is so new in human history that most men have not grasped it fully to this day. In accordance with the two theories of ethics, the mystical or the social, some men assert that rights are a gift of God — other, that rights are a gift of society. But, in fact, the source of rights is man's nature.

#### Source of our rights

The Declaration of Independence stated that men “are endowed by their Creator with certain unalienable rights.” Whether one believes that man is the product of a Creator or of nature, the issue of man's origin does not

Without property rights, no other rights are possible. Since man has to sustain his life by his own effort, the man who has no right to the product of his effort has no means to sustain his life. The man who produces while others dispose of his product is a slave.

alter the fact that he is an entity of a specific kind — a rational being — that he cannot function successfully under coercion, and that rights are a necessary condition of his particular mode of survival.

“The source of man's rights is not divine law or congressional law, but the law of identity. A is A — and Man is Man. Rights are conditions of existence required by man's nature for his proper survival. If man is to live on earth, it is right for him to use his mind, it is right to act on his own free judgment, it is right to work for his values and to keep the product of his work. If life on earth is his purpose, he has a right to live as a rational being: Nature forbids him the irrational.” (*Atlas Shrugged*)

To violate man's rights means to compel him to act against his own judgment, or to expropriate his values. Basically, there is only one way to do it: by the use of physical force. There are two potential violators of man's rights: the criminals and the government. The great achievement of the United States was to draw a distinction between these two — by forbidding to the second the legalized version of the activities of the first.

The Declaration of Independence laid down the principle that “to secure these rights, governments are instituted among men.” This provided the only valid justification

of a government and defined its only proper purpose: to protect man's rights by protecting him from physical violence.

Thus the government's function was changed from the role of ruler to the role of servant. The government was set to protect man from criminals — and the Constitution was written to protect man from the government. The Bill of Rights was not directed against private citizens, but against the government — as an explicit declaration that individual rights supersede any public or social power.

The result was the pattern of a civilized society which — for the brief span of some 150 years — America came close to achieving. A civilized society is one in which physical force is banned from human relationships — in which the government, acting as a policeman, may use force only in retaliation and only against those who initiate its use.

This was the essential meaning and intent of America's political philosophy, implicit in the principle of individual rights. But it was not formulated explicitly, nor fully accepted nor consistently practiced.

America's inner contradiction was the altruist collectivist ethics. Altruism is incompatible with freedom, with capitalism and with individual rights. One cannot combine the pursuit of happiness with the moral status of a sacrificial animal.

It was the concept of individual rights that had given birth to a free society. It was with the destruction of individual rights that the destruction of freedom had to begin.

A collectivist tyranny dare not enslave a country by an outright confiscation of its values, material or moral. It has to be done by a process of internal corruption. Just as in the material realm the plundering of a country's wealth is accomplished by inflating the currency, so today one may witness the process of inflation being applied to the realm of rights. The process entails such a growth of newly promulgated “rights” that people do not notice the fact that the meaning of the concept is being reversed. Just as bad money drives out good money, so these “printing-press rights” negate authentic rights.

#### Meaning of ‘rights’

Consider the curious fact that never has there been such a proliferation, all over the world, of two contradictory phenomena: of alleged new “rights” and of slave labor camps.

The “gimmick” was the switch of the concept of rights from the political to the economic realm.

The Democratic Party platform of 1960 summarizes the switch boldly and explicitly. It declares that a Democratic administration “will reaffirm the economic bill of rights which Franklin Roosevelt wrote into our national conscience 16 years ago.

Bear clearly in mind the meaning of the concept of “rights” when you read the list which that platform offers:

- “1. The right to a useful and remunerative job in the industries or shops or farms or mines of the nation.
- “2. The right to earn enough to provide adequate food and clothing and recreation.
- “3. The right of every farmer to raise and sell his products at a return which will give him and his family a decent living.
- “4. The right of every businessman, large and small, to trade in an atmosphere of freedom from unfair competition and domination by monopolies at home and abroad.
- “5. The right of every family to a decent home.
- “6. The right to adequate medical care and the opportunity to achieve and enjoy good health.
- “7. The right to adequate protection from the economic fears of old age, sickness, accidents and unemployment.
- “8. The right to a good education.”

A single question added to each of the above eight clauses would make the issue



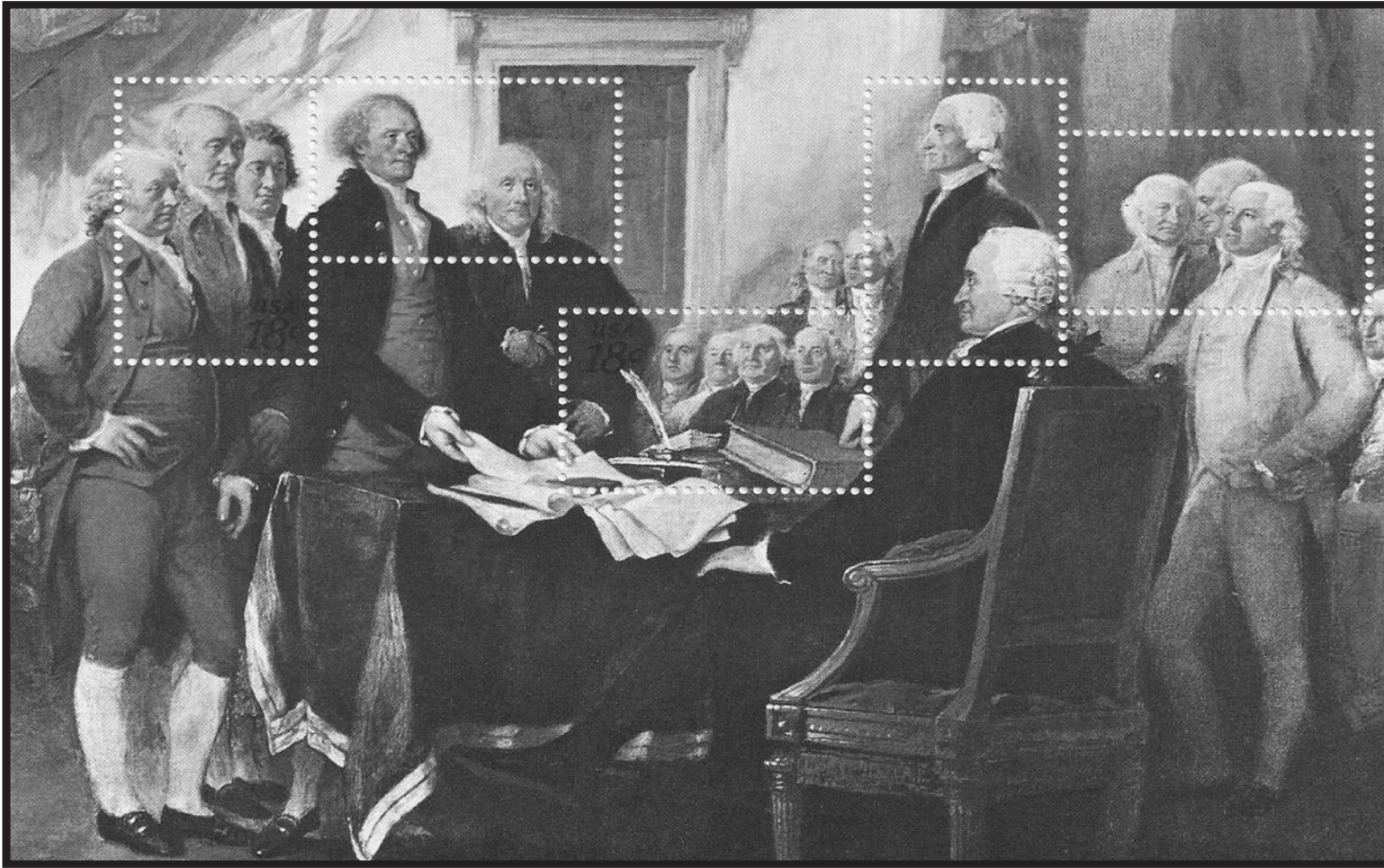

The Declaration of Independence laid down the principle that 'to secure these rights, governments are instituted among men.' This provided the only valid justification of a government and defined its only proper purpose: to protect man's rights by protecting him from physical violence. Thus the government's function was changed from the role of ruler to the role of servant.

clear: At whose expense?

Jobs, food, clothing, recreation (!), homes, medical care, education, etc., do not grow in nature. These are man-made values — goods and services produced by men. Who is to provide them?

If some men are entitled by right to the products of the work of others, it means that those others are deprived of rights and condemned to slave labor.

Any alleged "right" of one man, which necessitates the violation of the rights of another, is not and cannot be a right.

No man can have a right to impose an unchosen obligation, an unrewarded duty or an involuntary servitude on another man. There can be no such thing as "the right to enslave."

A right does not include the material implementation of that right by other men; it includes only the freedom to earn that implementation by one's own effort.

Observe, in this context, the intellectual precision of the Founding Fathers: They spoke of the right to the pursuit of happiness — not of the right to happiness. It means that a man has the right to take the actions he deems necessary to achieve his happiness; it does not mean that others must make him happy.

The right to life means that a man has the right to support his life by his own work (on any economic level, as high as his ability will carry him); it does not mean that others must provide him with the necessities of life.

The right to property means that a man has the right to take the economic actions necessary to earn property, to use it and to dispose of it; it does not

mean that others must provide him with property.

The right of free speech means that a man has the right to express his ideas without danger of suppression, interference or punitive action by the government. It does not mean that others must provide him with a lecture hall, a radio station or a printing press through which to express his ideas.

Any undertaking that involves more than one man requires the voluntary consent of every participant. Every one of them has the right to make his own decision, but none has the right to force his decision on the others.

There is no such thing as "a right to a job" — there is only the right of free trade, that is: a man's right to take a job if another man chooses to hire him. There is no "right to a home," only the right of free trade: the right to build a home or to buy it.

There are no "rights to a 'fair' wage or a 'fair' price" if no one chooses to pay it, to hire a man or to buy his product. There are no "rights of consumers" to milk, shoes, movies or champagne if no producers choose to manufacture such items (there is only the right to manufacture them oneself). There are no "rights" of special groups, there are no "rights of farmers, of workers, of businessmen, of employees, of employers, of the old, of the young, of the unborn."

There are only the Rights of Man — rights possessed by every individual man and by all men as individuals.

Property rights and the right of free trade are man's only "economic rights" (they are, in fact, political rights) — and there can be no such thing as "an economic bill of rights." But observe that



the advocates of the latter have all but destroyed the former.

Remember that rights are moral principles which define and protect a man's freedom of action, but impose no obligations on other men. Private citizens are not a threat to one another's rights or freedom. A private citizen who resorts to physical force and violates the rights of others is a criminal — and men have legal protection against him.

#### **Our biggest threat: Government**

Criminals are a small minority in any age or country. And the harm they have done to mankind is infinitesimal when compared to the horrors — the bloodshed, the wars, the persecutions, the confiscations, the famines, the enslavements, the wholesale destructions — perpetrated by mankind's governments.

Potentially, a government is the most dangerous threat to man's rights: It holds a legal monopoly on the use of physical force against legally disarmed victims. When unlimited and unrestricted by individual rights, a government is man's deadliest enemy. It is not as protection against private actions, but against governmental actions that the Bill of Rights was written.

And then there is Newton N. Minow who declares: "There is censorship by ratings, by advertisers, by networks, by affiliates which reject programming offered to their areas." It is the same Mr. Minow who threatens to revoke the license of any station that does not comply with his views on programming — and who claims that that is not censorship.

Consider the implications of such a trend.

"Censorship" is a term pertaining only to governmental action. No private action is censorship. No private individual or agency can silence a man or suppress a publication; only the government can do so. The freedom of speech of private individuals includes the right not to agree, not to listen and not to finance one's own antagonists.

But according to such doctrines as the "economic bill of rights," an individual has no right to dispose of his own material means by the guidance of his own convictions — and must hand over his money indiscriminately to any speakers or propagandists who have a "right" to his property.

This means that the ability to provide the material tools for the expression of ideas deprives a man of the right to hold any ideas. It means that a publisher has to publish books he considers worthless, false or evil — that a TV sponsor has to finance commentators who choose to affront his convictions — that the owner of a newspaper must turn his editorial pages over to any young hooligan who clamors for the enslavement of the press. It means that one group of men acquires the "right" to unlimited license — while another group is reduced to helpless irresponsibility.

But since it is obviously impossible to provide every claimant with a job, a microphone or a newspaper column, who will determine the "distribution" of "economic rights" and select the recipients, when the owners' right to choose has been abolished? Well, Mr. Minow has indicated that quite clearly.

And if you make the mistake of thinking that this applies only to big property owners, you had better realize that the theory of "economic rights" includes the "right" of every would-be playwright, every beatnik poet, every noise-composer and every non-objective artist (who have political pull) to the financial support you did not give them when you did not attend their shows. What else is the meaning of the project to spend your tax money on subsidized art?

And while people are clamoring about "economic rights," the concept of political rights is vanishing. It is forgotten that the right of free speech means the freedom to advocate one's views and to bear the possible consequences, including disagreement with others, opposition, unpopularity and lack of support. The political function of "the right of free speech" is to protect dissenters and unpopular minorities from forcible suppression — not to guarantee them the support, advantages and rewards of a popularity they have not gained.

The Bill of Rights reads: "Congress shall make no law . . . abridging the freedom of speech, or of the press ..." It does not demand that private citizens provide a microphone for the man who advocates their destruction, or a passkey for the burglar who seeks to rob them, or a knife for the murderer who wants to cut their throats.

Such is the state of one of today's most crucial issues: political rights versus "economic rights." It's either-or. One destroys the other. But there are, in fact, no "economic rights," no "collective rights," no "public-interest rights." The term "individual rights" is a redundancy: There is no other kind of rights, and no one else to possess them.

Those who advocate laissez-faire capitalism are the only advocates of man's rights.

There is only one fundamental right  
(all the others are its consequences or  
corollaries): a man's right to his own life.  
Life is a process of self-sustaining and  
self-generated action; the right  
to life means the right to engage in  
self-sustaining and self-generated action  
... Such is the meaning of the right to life,  
liberty, and the pursuit of happiness.

Now observe the process by which that protection is being destroyed.

The process consists of ascribing to private citizens the specific violations constitutionally forbidden to the government (which private citizens have no power to commit) and thus freeing the government from all restrictions. The switch is becoming progressively more obvious in the field of free speech. For years, the collectivists have been propagating the notion that a private individual's refusal to finance an opponent is a violation of the opponent's right of free speech and an act of "censorship."

It is "censorship," they claim, if a newspaper refuses to employ or publish writers whose ideas are diametrically opposed to its policy.

It is "censorship," they claim, if businessmen refuse to advertise in a magazine that denounces, insults and smears them.

It is "censorship," they claim, if a TV sponsor objects to some outrage perpetrated on a program he is financing — such as the incident of Alger Hiss being invited to denounce former Vice President Nixon.

