

PUBLIC NOTICES

An American Tradition

Public notice is an important tool in assuring an informed citizenry. Notices are mandated by legislatures to make sure there is a public window into the activities of governments, officers of the court and others holding a public trust. There are four key elements to a valid public notice. It should be executed by an entity outside the one mandated to provide notice, so proper checks and balances are in place.

A public notice informs citizens of government or government-related activities that affect citizens' everyday lives. A public notice typically has four elements:

- **Independent:** A public notice is published in a forum independent of the government, typically in a local newspaper.

- **Archivable:** A public notice is archived in a secure and publicly available format.

- **Accessible:** A public notice is capable of being accessed by all segments of society.

- **Verifiable:** The public and the source of the notice are able to verify that the notice was published, usually by an affidavit provided by the publisher.

(Adapted from the Public Resource Notice Center)

Types of Public Notices

There are three standard types:

- **Citizen participation notices** inform the public about proposed government action and allow the public time to react to such proposals.

One such example is a public hearing notice.

- **Business and commerce notices**

relate to government contracts and purchases. Notices of contract bids allow citizens to ensure that the government is operating in accordance with principles of equal opportunity and is acting responsibly in spending taxpayer money.

- **Court notices** are required of many non-governmental entities that

use public powers or institutions in some way. Examples include notices of home mortgage foreclosures, which can provide a public alert of widespread credit problems, fraud in underwriting and a basis for analyses of housing trends.

This notice allows the public to object to an appointment based on any conflict of interest.

The history of public notices

Public notices existed long before the emergence of newspapers. The concept itself began when early civilizations posted notices in public squares. This crude method was eventually refined with the publication of the first English language newspaper in 1665 — a court newspaper called the Oxford Gazette. After being renamed The London Gazette, this official newspaper carried notices from the King's Court, London

officials and outlying regions.

The American system is modeled after the British system. State governments published public notices before America's founding, and the newly-created federal government followed suit. In 1789, the Acts of the First Congress required the Secretary of State to publish all bills, orders, resolutions and congressional votes in at least three publicly available newspapers.

An important premise both in federal

and local governments of the United States, as well as in many republics around the world, is that information about government activities must be accessible for the electorate to make well-informed decisions.

Public notices in newspapers still provide this accessibility to citizens who want to know more about government activities. Public notice laws serve to outline the most effective method of reaching the public.

Public notice supports due process

Public notices are integral to democratic governance and stem from the right to "due process of law" guaranteed by the federal and state constitutions. Due process of law protects Americans' rights from arbitrary or wrongful violations. This concept has two parts: substantive due process and procedural due process.

Substantive due process refers to the

types of rights that are protected. Procedural due process refers to the means of protecting those rights.

Substantive due process ensures that certain basic rights are not violated, while procedural due process may require suitable notice and a hearing before a government or court-appointed body can act in a way that may affect those basic rights.

Public notices play a vital role in

substantive and procedural due process because they provide a window into government actions and also afford notice to citizens of actions about to take place so they may exercise their constitutional right to be heard. Notification not only informs the individual or entity most directly affected, but it also informs the public, which has an interest in knowing how public powers are being used.

WHY NEWSPAPERS?

Newspapers are the primary source

Newspapers, founded on the constitutional right of free press, have been serving the public's right to know in America since pre-colonial times and on the European continent since the 17th century. Because of their traditional information role in society and their long-established independence, newspapers remain the primary source for publishing public notices.

Upholding the public's right to know is essential to our country's way of life. Our government governs with the consent of the people, and this consent must be informed. Local newspapers keep the public informed about the inner workings of their respective state and local governments, thereby allowing citizens to participate more fully in the democratic process. Without this participation, the potential for misguided policies increases.

Newspaper tradition

Newspapers allow the government to notify the public of government actions. The government has a fundamental responsibility to ensure adequate notification to the public of its actions. Therefore, the government has a duty to make sure the methods used in satisfying this responsibility are the most effective.

Newspapers provide neutrality from government and credible distance from political pressures or partisan disagreements. Local and community newspapers serve as third-party reporters to the public, publishing information that can be beneficial or sometimes detrimental to the government's public image. They provide an environment for notices that the

public traditionally has regarded as neutral. Public notices in this print environment gain credibility because of the long history of trust in the local newspaper.

Placing notices on government Web sites undermines this neutral interest and removes a critical check and balance. While it may seem appealing on the surface in an age of ever-more sophisticated government Web sites, the potential for mishandling is great.

On the other hand, public notices in independent newspapers increase government transparency by opening up the decision-making process to the public's eyes. Without this oversight, local governments could enact controversial policies without input from the public.

Newspapers serve as effective monitors of governments and ensure that they publish information as required by law. Public notices are typically required by a statute or a regulation. The independent press can provide a valuable civic role by helping to monitor that the notices were published when required. If governments were responsible for publishing their own notices, no neutral and independent entity would have the incentive and the means to track public-notice publication.

Newspapers: The best medium for public notices

Newspapers, for the most of the republic's history, have been the accepted medium for public notices. This is exactly where the public, even infrequent readers, expects to find them. In addition, specialized publications, such as legal newspapers, are well known for

providing public notices to the population through legal communities. Other general interest newspapers, such as county seat weeklies, are the forum where county citizens expect to locate notices of important public business. Furthermore, the vast majority of these notices arrive at citizens' homes in a context that compels readership (amid local news, sports features and other content).

Another reason for the effectiveness of newspapers is that newspapers provide valid evidence of readership.

Legislatures are rightly concerned about web-only notices, given the digital divide between rich and poor, rural and urban residents. The Internet is either too costly or simply geographically unavailable to large segments of society.

Notices become historical records

The newspaper as paper of record is an important factor in the public policy of notices. Government Web sites cannot provide a secure archival history the way newspapers can. Electronic records lack permanence and can easily be intentionally or accidentally erased. Even the Library of Congress has recognized this shortcoming and has embarked upon a major project to attempt to archive digital records that are in danger of being "forever lost" due to Internet impermanence.

Despite these problems, the federal courts unwisely approved a rule change to the Federal Rules of Civil Procedure recently that would

THE RISKS OF NOTICES ONLY ON THE INTERNET

Although it has been part of American society for a quarter-century as a network for scholars and government agencies, the Internet has been widely used by citizens for about 15 years.

Because of its structure with computer clients and servers, information packets and open-network codes, the Internet remains vulnerable and sometimes unstable. Power surges, corrupted software and downed servers can disrupt access. Government agencies cannot ensure that information located on a server is secure.

Even a highly technological site like that of the Pentagon's has been affected. In June 2007, the Pentagon was forced to take about 1,500 computers off-line because of a cyber-attack. Then-Defense Department Secretary Robert Gates stated that the Pentagon sees hundreds of attacks every day.

Public notices guard our constitutional right to due process of law by informing citizens of government action and providing proof of publication via notarized affidavits of publication. Unlike the time-tested and trusted local newspapers that citizens have come to rely on for public notices, the Internet is an unstable medium for information. While it is valuable tool in disseminating information, it has not yet reached a level of sophistication and technological stability that would justify its supplanting newspapers as the primary venue for public notices.

It is still uncertain how a "Net" affidavit could show proof of a public notice publication when constant technological change makes any attempt at archiving and accessing such a document online for any significant time dubious.

No less problematic for the Internet is its reach. Those who live in rural areas where broadband does not exist and others who simply cannot afford the Internet cannot access web public notices. In situations where foreclosures are on the rise due, in part, to predatory mortgage lending, more, not less, access to public notices is needed to better inform citizens about their rights and their choices.

It is difficult to justify, then, moving public notices from newspapers only to public-notice Web sites administered either by already over-burdened state governments or by third-party vendors who lack the experience and long-term viability newspapers have proven in publishing notices.

So far in the Internet age, newspapers remain the most trusted and primary method for providing citizens access to public notices.

move notices of federal asset forfeitures out of newspapers and onto a Web site administered by the Department of Justice. Yet, the courts have little research to show that the Justice Department's Web site will produce viable, accessible, archivable notices.

While Internet web pages pose serious archiving challenges, newspapers, on the other hand, become historical documents. They are oriented and published with a date on every page. They cannot be deceptively altered after printing as a web page could. Historians, judges, lawyers, genealogists and researchers, to name only a few, use newspapers and public notices in particular as sources for records.

Newspaper notices protect due process

Procedural due process, as granted by the U.S. Constitution and interpreted

by courts, generally requires an individual to receive notice and a hearing before he or she is deprived of certain rights or property. For example, before a person's home is sold by a county sheriff at a foreclosure sale, he or she must receive notice of the foreclosure sale and an opportunity to save the house from foreclosure. If the owner does not receive the notice, he may challenge the sale in court. The court may then void the sale or prevent the sale from happening to protect due process.

Newspapers are generally paid to run public notices, which recognizes that their publication creates a cost in paper, ink and delivery.



FIRST INSERTION

NOTICE TO CREDITORS
IN THE CIRCUIT COURT
FOR SARASOTA COUNTY,
FLORIDA
PROBATE DIVISION
File No. 2014 CP 002001 NC
IN RE: ESTATE OF
PAULINE M. SIVERTSEN
Deceased.

The administration of the estate of PAULINE M. SIVERTSEN, deceased, whose date of death was April 22, 2014; is pending in the Circuit Court for Sarasota County, Florida, Probate Division; File Number 2014 CP 1187 NC; the address of which is P.O. Box 48927, Sarasota, FL 34230. The name and address of the personal representative and the personal representative's attorney are set forth below.

All creditors of the decedent and other persons, who have claims or demands against decedent's estate, including unmatured, contingent or unliquidated claims, and who have been served a copy of this notice, must file their claims with this court WITHIN THE LATER OF THREE (3) MONTHS AFTER THE DATE OF THE FIRST PUBLICATION OF THIS NOTICE OR THIRTY (30) DAYS AFTER THE DATE OF SERVICE OF A COPY OF THIS NOTICE ON THEM.

All other creditors of the decedent and other persons having claims or demands against decedent's estate, including unmatured, contingent or unliquidated claims, must file their claims with this court WITHIN THREE (3) MONTHS AFTER THE DATE OF THE FIRST PUBLICATION OF THIS NOTICE.

ALL CLAIMS NOT SO FILED WILL BE FOREVER BARRED.

NOTWITHSTANDING THE TIME PERIODS SET FORTH ABOVE, ANY CLAIM FILED TWO (2) YEARS OR MORE AFTER THE DECEDENT'S DATE OF DEATH IS BARRED.

THE DATE OF FIRST PUBLICATION OF THIS NOTICE IS: May 23, 2014.

Personal Representative:

KAREN SELLERS
4084 47TH St.
Sarasota, FL 34235
Attorney for Personal Representative:
George Browning III, PA
Attorney
Florida Bar No. 125555
46 N. Washington Blvd.
No. 27
Sarasota, FL 34236
941 366 2782
May 23, 30, 2014 14-02326S

FIRST INSERTION

NOTICE TO CREDITORS
IN THE CIRCUIT COURT FOR
SARASOTA COUNTY, FLORIDA
File No. 2014-CP-001951 NC
Probate Division
IN RE: ESTATE OF
MARY ANNE KADY,
Deceased.

The administration of the estate of MARY ANNE KADY, deceased, whose date of death was January 29, 2014, is pending in the Circuit Court for Sarasota County, Florida, Probate Division, the address of which is P. O. Box 3079, Sarasota, FL 34230. The names and addresses of the personal representative and the personal representative's attorney are set forth below.

All creditors of the decedent and other persons having claims or demands against decedent's estate, on whom a copy of this notice is required to be served, must file their claims with this court ON OR BEFORE THE LATER OF 3 MONTHS AFTER THE TIME OF THE FIRST PUBLICATION OF THIS NOTICE OR 30 DAYS AFTER THE DATE OF SERVICE OF A COPY OF THIS NOTICE ON THEM.

All other creditors of the decedent and other persons having claims or demands against decedent's estate must file their claims with this court WITHIN 3 MONTHS AFTER THE DATE OF THE FIRST PUBLICATION OF THIS NOTICE.

ALL CLAIMS NOT FILED WITHIN THE TIME PERIODS SET FORTH IN SECTION 733.702 OF THE FLORIDA PROBATE CODE WILL BE FOREVER BARRED.

NOTWITHSTANDING THE TIME PERIOD SET FORTH ABOVE, ANY CLAIM FILED TWO (2) YEARS OR MORE AFTER THE DECEDENT'S DATE OF DEATH IS BARRED.

The date of first publication of this notice is: May 23, 2014.

Signed on May 20, 2014.

LISA KADY HOFFMAN

Personal Representative
2732 Hatton Street
Sarasota, FL 34237
Charla M. Burchett, Esquire
Attorney for Personal Representative
Florida Bar No. 0813230
Charla M. Burchett, PLC
766 Hudson Avenue,
Ste. C
Sarasota, FL 34236-7739
Telephone: (941)-951-1866
Email: cmb@burchettlaw.com
Secondary E-mail:
court@burchettlaw.com
May 23, 30, 2014 14-02325S

FIRST INSERTION

NOTICE TO CREDITORS
IN THE CIRCUIT COURT FOR
SARASOTA COUNTY, FLORIDA
PROBATE DIVISION
File No. 2014-CP-001718-NC
IN RE: ESTATE OF
STEVEN E. FISHER
Deceased.

The administration of the estate of STEVEN E. FISHER, deceased, whose date of death was March 18, 2014; File Number 2014-CP-001718-NC, is pending in the Circuit Court for Sarasota County, Florida, Probate Division, the address of which is 2000 Main Street, Sarasota, Florida 34237. The names and addresses of the personal representative and the personal representative's attorney are set forth below.

All creditors of the decedent and other persons having claims or demands against decedent's estate, on whom a copy of this notice is required to be served must file their claims with this court ON OR BEFORE THE LATER OF 3 MONTHS AFTER THE TIME OF THE FIRST PUBLICATION OF THIS NOTICE OR 30 DAYS AFTER THE DATE OF SERVICE OF A COPY OF THIS NOTICE ON THEM.

All other creditors of the decedent and other persons having claims or demands against decedent's estate must file their claims with this court WITHIN 3 MONTHS AFTER THE DATE OF THE FIRST PUBLICATION OF THIS NOTICE.

ALL CLAIMS NOT FILED WITHIN THE TIME PERIODS SET FORTH IN SECTION 733.702 OF THE FLORIDA PROBATE CODE WILL BE FOREVER BARRED.

NOTWITHSTANDING THE TIME PERIOD SET FORTH ABOVE, ANY CLAIM FILED TWO (2) YEARS OR MORE AFTER THE DECEDENT'S DATE OF DEATH IS BARRED.

The date of first publication of this notice is: May 23, 2014.

KRISTEN IRENE FISHER f/k/a KRISTEN FISHER-JARVIS

Personal Representative
2503 East Central Boulevard, Unit 15
Orlando, Florida 32803
Mary Lynn Desjarlais
Attorney for Personal Representative
Email:
mldesjarlais@attorneydesjarlais.com
Secondary Email: none
Florida Bar No. 0347469
Mary Lynn Desjarlais, P.A.
2750 Stickney Point Road,
Suite 201
Sarasota, FL 34231
Telephone: 941-923-3388
May 23, 30, 2014 14-02333S

FIRST INSERTION

NOTICE TO CREDITORS
IN THE CIRCUIT COURT FOR
SARASOTA COUNTY, FLORIDA
PROBATE DIVISION
File No. 2014 CP 1917 NC
IN RE: ESTATE OF
SAM P. DAVIS JR.,
Deceased.

The administration of the estate of SAM P. DAVIS JR., deceased, whose date of death was April 21, 2014, is pending in the Circuit Court for Sarasota County, Florida, Probate Division, the address of which is P.O. Box 3079, Sarasota, FL 34230. The names and addresses of the personal representative and the personal representative's attorney are set forth below.

All creditors of the decedent and other persons having claims or demands against decedent's estate on whom a copy of this notice is required to be served must file their claims with this court ON OR BEFORE THE LATER OF 3 MONTHS AFTER THE TIME OF THE FIRST PUBLICATION OF THIS NOTICE OR 30 DAYS AFTER THE DATE OF SERVICE OF A COPY OF THIS NOTICE ON THEM.

All other creditors of the decedent and other persons having claims or demands against decedent's estate must file their claims with this court WITHIN 3 MONTHS AFTER THE DATE OF THE FIRST PUBLICATION OF THIS NOTICE.

ALL CLAIMS NOT FILED WITHIN THE TIME PERIODS SET FORTH IN SECTION 733.702 OF THE FLORIDA PROBATE CODE WILL BE FOREVER BARRED.

NOTWITHSTANDING THE TIME PERIOD SET FORTH ABOVE, ANY CLAIM FILED TWO (2) YEARS OR MORE AFTER THE DECEDENT'S DATE OF DEATH IS BARRED.

The date of first publication of this notice is May 23, 2014.

Personal Representative:

THE NORTHERN TRUST COMPANY
1515 Ringling Boulevard
Sarasota, FL 34236
Attorney for Personal Representative:
WILLIAM T. HARRISON
Florida Bar No. 0034232
Williams Parker Harrison Dietz & Getzen
200 S. Orange Ave.
Sarasota, FL 34236
Telephone: 941-366-4800
Designation of Email Addresses for service:
Primary:
wharrison@williamsparker.com
Secondary:
ltraver@williamsparker.com
May 23, 30, 2014 14-02327S

FIRST INSERTION

NOTICE TO CREDITORS
IN THE CIRCUIT COURT FOR
SARASOTA COUNTY, FLORIDA
PROBATE DIVISION
File No. 2014 CP 1984 PR
IN RE: ESTATE OF
MILDRED T. BAKER
a.k.a MILDRED BAKER
Deceased.

The administration of the estate of MILDRED T. BAKER a.k.a. MILDRED BAKER, deceased, whose date of death was May 6, 2014, is pending in the Circuit Court for SARASOTA County, Florida, Probate Division, the post office address of which is P.O. Box 3079, Sarasota, Florida 34230-3079. The names and addresses of the personal representative and the personal representative's attorney are set forth below.

All creditors of the decedent and other persons having claims or demands against decedent's estate on whom a copy of this notice is required to be served must file their claims with this court WITHIN THE LATER OF 3 MONTHS AFTER THE TIME OF THE FIRST PUBLICATION OF THIS NOTICE OR 30 DAYS AFTER THE DATE OF SERVICE OF A COPY OF THIS NOTICE ON THEM.

All other creditors of the decedent and other persons having claims or demands against decedent's estate must file their claims with this court WITHIN 3 MONTHS AFTER THE DATE OF THE FIRST PUBLICATION OF THIS NOTICE.

ALL CLAIMS NOT FILED WITHIN THE TIME PERIODS SET FORTH IN SECTION 733.702 OF THE FLORIDA PROBATE CODE WILL BE FOREVER BARRED.

NOTWITHSTANDING THE TIME PERIOD SET FORTH ABOVE, ANY CLAIM FILED TWO (2) YEARS OR MORE AFTER THE DECEDENT'S DATE OF DEATH IS BARRED.

The date of first publication of this notice is May 23, 2014.

Personal Representative:

ROBERT P. SCHEB
2750 Ringling Blvd., Suite 3
Sarasota, Florida 34237
Attorney for Personal Representative:
ROBERT P. SCHEB
E-Mail Address:
rscheb@bowmangeorge.com
Florida Bar No. 398519
BOWMAN, GEORGE, SCHEB, KIMBROUGH & KOACH, P.A.
2750 Ringling Boulevard, Suite 3
Sarasota, Florida 34237
Telephone (941) 366-5510
May 23, 30, 2014 14-02334S

FIRST INSERTION

NOTICE TO CREDITORS
IN THE CIRCUIT COURT FOR
SARASOTA COUNTY, FLORIDA
PROBATE DIVISION
File No. 2014 CP 1983 PR
IN RE: ESTATE OF
ROLAND R. BRASSARD
Deceased.

The administration of the ROLAND R. BRASSARD, deceased, whose date of death was April 27, 2014, is pending in the Circuit Court for SARASOTA County, Florida, Probate Division, the post office address of which is P.O. Box 3079, Sarasota, Florida 34230-3079. The names and addresses of the personal representative and the personal representative's attorney are set forth below.

All creditors of the decedent and other persons having claims or demands against decedent's estate on whom a copy of this notice is required to be served must file their claims with this court WITHIN THE LATER OF 3 MONTHS AFTER THE TIME OF THE FIRST PUBLICATION OF THIS NOTICE OR 30 DAYS AFTER THE DATE OF SERVICE OF A COPY OF THIS NOTICE ON THEM.

All other creditors of the decedent and other persons having claims or demands against decedent's estate must file their claims with this court WITHIN 3 MONTHS AFTER THE DATE OF THE FIRST PUBLICATION OF THIS NOTICE.

ALL CLAIMS NOT FILED WITHIN THE TIME PERIODS SET FORTH IN SECTION 733.702 OF THE FLORIDA PROBATE CODE WILL BE FOREVER BARRED.

NOTWITHSTANDING THE TIME PERIOD SET FORTH ABOVE, ANY CLAIM FILED TWO (2) YEARS OR MORE AFTER THE DECEDENT'S DATE OF DEATH IS BARRED.

The date of first publication of this notice is May 23, 2014.

Personal Representative:

Patricia B. Small
18 Dalton Parkway
Salem, Massachusetts 01970-3110
Attorney for Personal Representative:
ROBERT P. SCHEB
E-Mail Address:
rscheb@bowmangeorge.com
Florida Bar No. 398519
BOWMAN, GEORGE, SCHEB, KIMBROUGH & KOACH, P.A.
2750 Ringling Boulevard, Suite 3
Sarasota, Florida 34237
Telephone (941) 366-5510
May 23, 30, 2014 14-02335S

FIRST INERTION

NOTICE TO CREDITORS
IN THE CIRCUIT COURT FOR
SARASOTA COUNTY, FLORIDA
PROBATE DIVISION
File No. 2014 CP 001940 NC
IN RE: ESTATE OF
MARY ELIZABETH BLOECHL
a.k.a ELIZABETH A. BLOECHL
a.k.a MARY ELIZABETH ARNALL
BLOECHL
a.k.a MARY A. BLOECHL
a.k.a MARY B. BLOECHL
a.k.a BETH A. BLOECHL
Deceased.

The administration of the estate of MARY ELIZABETH BLOECHL, a.k.a ELIZABETH A. BLOECHL, a.k.a MARY ELIZABETH ARNALL BLOECHL, a.k.a MARY A. BLOECHL, a.k.a MARY B. BLOECHL, a.k.a BETH A. BLOECHL, deceased, whose date of death was April 28, 2014, and whose social security number are xxx-xx-0684, is pending in the Circuit Court for Sarasota County, Florida, Probate Division, the address of which

is P. O. Box 3079, Sarasota, Florida 34230. The names and addresses of the personal representatives and the personal representatives' attorney are set forth below.

All creditors of the decedent and other persons having claims or demands against decedent's estate on whom a copy of this notice is required to be served must file their claims with this court WITHIN THE LATER OF 3 MONTHS AFTER THE TIME OF THE FIRST PUBLICATION OF THIS NOTICE OR 30 DAYS AFTER THE DATE OF SERVICE OF A COPY OF THIS NOTICE ON THEM.

All other creditors of the decedent and other persons having claims or demands against decedent's estate must file their claims with this court WITHIN 3 MONTHS AFTER THE DATE OF THE FIRST PUBLICATION OF THIS NOTICE.

ALL CLAIMS NOT FILED WITHIN THE TIME PERIODS SET FORTH IN SECTION 733.702 OF THE FLORIDA PROBATE CODE

WILL BE FOREVER BARRED.

NOTWITHSTANDING THE TIME PERIOD SET FORTH ABOVE, ANY CLAIM FILED TWO (2) YEARS OR MORE AFTER THE DECEDENT'S DATE OF DEATH IS BARRED.

The date of first publication of this notice is May 23, 2014.

Personal Representatives:

MARK W. BLOECHL
11914 Shadow Run Boulevard
Riverview, Florida 33569-6316
SUSAN B. GAILLARD
2471 Arlington Street
Sarasota, Florida 34239
Attorney for Personal Representative:
JOHN J. LYONS, Esq.
E-Mail Address:
john@lyonsbeaudryharrison.com
E-Mail Address:
ann@lyonsbeaudryharrison.com
Florida Bar No. 049193
LYONS, BEAUDRY & HARRISON, P.A.
1605 Main Street, Suite. 1111
Sarasota, Florida 34236-5809
Telephone: (941) 366-3282
May 23, 30, 2014 14-02337S

FIRST INSERTION

Notice Under Fictitious Name Law Pursuant to Section 865.09, Florida Statutes
NOTICE IS HEREBY GIVEN that the undersigned, desiring to engage in business under the fictitious name of World Choice Franchises located at 4426 Antioch St, in the County of Sarasota in the City of North Port, Florida 34228 intends to register the said name with the Division of Corporations of the Florida Department of State, Tallahassee, Florida.
Dated at Sarasota, Florida, this 14th day of May, 2014.
Falco Enterprises LLC
May 23, 2014 14-02249S

FIRST INSERTION

Notice Under Fictitious Name Law Pursuant to Section 865.09, Florida Statutes
NOTICE IS HEREBY GIVEN that Thomas Ranch Land Partners North Port, LLLP, a Florida limited partnership, located at 200 South Orange Avenue, Sarasota, Florida 34236, County of Sarasota, intends to transact business under the fictitious name of Thomas Ranch and to register the fictitious name with the Florida Division of Corporations. Dated this 21st day of May 2014.
May 23, 2014 14-02339S

FIRST INERTION

NOTICE TO CREDITORS
IN THE CIRCUIT COURT FOR
SARASOTA COUNTY, FLORIDA
PROBATE DIVISION
File No. 2014-CP-1977 NC
IN RE: ESTATE OF
DONALD W. DITZ
Deceased.

The administration of the DONALD W. DITZ, deceased, whose date of death was May 7, 2014, is pending in the Circuit Court for SARASOTA County, Florida, Probate Division, the post office address of which is P.O. Box 3079, Sarasota, Florida 34230-3079. The names and addresses of the personal representative and the personal representative's attorney are set forth below.

All creditors of the decedent and other persons having claims or demands against decedent's estate on whom a copy of this notice is required to be served must file their claims with this court WITHIN THE LATER OF 3 MONTHS AFTER THE TIME OF THE FIRST PUBLICATION OF THIS NOTICE OR 30 DAYS AFTER THE DATE OF SERVICE OF A COPY OF THIS NOTICE ON THEM.

All other creditors of the decedent and other persons having claims or demands against

decedent's estate must file their claims with this court WITHIN 3 MONTHS AFTER THE DATE OF THE FIRST PUBLICATION OF THIS NOTICE.

ALL CLAIMS NOT FILED WITHIN THE TIME PERIODS SET FORTH IN SECTION 733.702 OF THE FLORIDA PROBATE CODE WILL BE FOREVER BARRED.

NOTWITHSTANDING THE TIME PERIOD SET FORTH ABOVE, ANY CLAIM FILED TWO (2) YEARS OR MORE AFTER THE DECEDENT'S DATE OF DEATH IS BARRED.

The date of first publication of this notice is May 23, 2014.

Personal Representative:

MICHAEL W. DITZ
P.O. Box 7311
Santa Monica, California 90406
Attorney for Personal Representative:
ROBERT P. SCHEB
E-Mail Address:
rscheb@bowmangeorge.com
Florida Bar No. 398519
BOWMAN, GEORGE, SCHEB, KIMBROUGH & KOACH, P.A.
2750 Ringling Boulevard,
Suite 3
Sarasota, Florida 34237
Telephone (941) 366-5510
May 23, 30, 2014 14-02336S

FIRST INSERTION

NOTICE OF RESCHEDULED SALE
IN THE CIRCUIT COURT OF THE
TWELFTH JUDICIAL CIRCUIT
IN AND FOR SARASOTA COUNTY,
FLORIDA
CIVIL ACTION
CASE NO.: 2011 CA 000312 NC
DIVISION: A
WELLS FARGO BANK, N.A.,
Plaintiff, vs.
LUBOV MELNICHENKO, et al,
Defendant(s).

NOTICE IS HEREBY GIVEN Pursuant to an Order Rescheduling Foreclosure Sale dated on or about April 11, 2014, and entered in Case No. 2011 CA 000312 NC of the Circuit Court of the Twelfth Judicial Circuit in and for Sarasota County, Florida in which Wells Fargo Bank, N.A., is the Plaintiff and Lubov Melnichenko, Pavel Melnichenko, are defendants, the Sarasota County Clerk of the Circuit Court will sell to the highest and best bidder for cash in/on the Internet: www.sarasota.realforeclose.com, Sarasota County, Florida at 9:00am on the 10th day of June, 2014, the following described property as set forth in said Final Judgment of Foreclosure:

LOT 1, BLOCK 558, OF EIGHTEENTH ADDITION TO PORT CHARLOTTE SUBDIVISION, ACCORDING TO THE PLAT THEREOF, AS RECORDED IN PLAT BOOK 14, PAGES 6, 6A THROUGH 6V, OF THE PUBLIC RECORDS OF SARASOTA COUNTY, FLORIDA.

A/K/A 2652 PEAKE STREET, NORTH PORT, FL 34286
Any person claiming an interest in the surplus from the sale, if any, other than the property owner as of the date of the Lis Pendens must file a claim within 60 days after the sale.

If you are a person with a disability who needs any accommodation in order to participate in this proceeding, you are entitled, at no cost to you, to the provision of certain assistance. Please contact the Sarasota County Jury Office, P.O. Box 3079, Sarasota, Florida 34230-3079, (941)861-7400, at least seven (7) days before your scheduled court appearance, or immediately upon receiving this notification if the time before the scheduled appearance is less than seven (7) days; if you are hearing or voice impaired, call 711.

/s/ Douglas Gerber
August J. Stanton, III
Florida Bar No. 0976113
Douglas Gerber
Florida Bar No. 15269
STANTON & GASKICK, P.A.
390 N. Orange Avenue,
Suite 260
Orlando, Florida 32801
Ph. (407) 423-5203; Fax 425-4105
E-mail:
pleadings@sg-law.us/rmf@sg-law.us
ATTORNEYS FOR PLAINTIFF
ATTORNEYS FOR PLAINTIFF
May 23, 30, 2014 14-02290S

FIRST INSERTION

NOTICE OF SALE
IN THE CIRCUIT COURT OF THE
TWELFTH JUDICIAL CIRCUIT, IN
AND FOR SARASOTA COUNTY,
FLORIDA
CASE NO.: 2013-CA-007940
CNLBank,
Plaintiff, vs.
MARC BEAULIEU and PAMELA
BEAULIEU, et al,
Defendants.

Notice is hereby given that, pursuant to a Final Judgment of Foreclosure entered in the above-styled cause, in the Circuit Court of Sarasota County, Florida, the Clerk of the Court will sell the property situated in Sarasota County, Florida, described as:

Unit No. 9 of Portofino of Venice, a Land Condominium according to The Declaration of Condominium recorded in Instrument #2005281485, and all exhibits and amendments thereof, and recorded in Condominium Book 38, Page 44, Public Records of Sarasota County, Florida.

at public sale, to the highest and best bidder, for cash, at 9:00 a.m. on the 27th day of June, 2014, via online sale at www.sarasota.realforeclose.com

ANY PERSON CLAIMING AN INTEREST IN THE SURPLUS FROM THE SALE, IF ANY, OTHER THAN THE PROPERTY OWNER AS OF THE DATE OF THE LIS PENDENS MUST FILE A CLAIM WITHIN 60 DAYS AFTER THE SALE PER SECTION 45.031, FLORIDA STATUTES.

If you are a person with a disability who needs any accommodation in order to participate in this proceeding, you are entitled, at no cost to you, to the provision of certain assistance. Please contact the Sarasota County Jury Office, P.O. Box 3079, Sarasota, Florida 34230-3079, (941)861-7400, at least seven (7) days before your scheduled court appearance, or immediately upon receiving this notification if the time before the scheduled appearance is less than seven (7) days; if you are hearing or voice impaired, call 711.

/s/ Douglas Gerber
August J. Stanton, III
Florida Bar No. 0976113
Douglas Gerber
Florida Bar No. 15269
STANTON & GASKICK, P.A.
390 N. Orange Avenue,
Suite 260
Orlando, Florida 32801
Ph. (407) 423-5203; Fax 425-4105
E-mail:
pleadings@sg-law.us/rmf@sg-law.us
ATTORNEYS FOR PLAINTIFF
ATTORNEYS FOR PLAINTIFF
May 23, 30, 2014 14-02304S

FIRST INSERTION

NOTICE TO CREDITORS
IN THE CIRCUIT COURT FOR
SARASOTA COUNTY, FLORIDA
PROBATE DIVISION
File No. 2014 CP 001980 NC
IN RE: ESTATE OF
IDA SCHUPPIN MILLER
a.k.a. IDA S. MILLER
a.k.a IDA GERTRUDE SCHUPPIN
MILLER
Deceased.

The administration of the estate of IDA SCHUPPIN MILLER a.k.a. IDA S. Miller a.k.a IDA GERTRUDE SCHUPPIN MILLER, deceased, whose date of death was April 26, 2014, and whose social security number are xxx-xx-9738, is pending in the Circuit Court for SARASOTA County, Florida, Probate Division, the address of which is P. O. Box 3079, Sarasota, Florida 34230. The names and addresses of the personal representative and the personal representative's attorney are set forth below.

All creditors of the decedent and other persons having claims or demands against decedent's estate on whom a copy of this notice is required to be served must file their claims with this court WITHIN THE LATER OF 3 MONTHS AFTER THE TIME OF THE FIRST PUBLICATION OF THIS NOTICE OR 30 DAYS AFTER THE DATE OF SERVICE OF A COPY OF THIS NOTICE ON THEM.

All other creditors of the decedent and other persons having claims or demands against decedent's estate must file their claims with this court WITHIN 3 MONTHS AFTER THE DATE OF THE FIRST PUBLICATION OF THIS NOTICE.

ALL CLAIMS NOT FILED WITHIN THE TIME PERIODS SET FORTH IN SECTION 733.702 OF THE FLORIDA PROBATE CODE WILL BE FOREVER BARRED.

NOTWITHSTANDING THE TIME PERIOD SET FORTH ABOVE, ANY CLAIM FILED TWO (2) YEARS OR MORE AFTER THE DECEDENT'S DATE OF DEATH IS BARRED.

The date of first publication of this notice is May 23, 2014.

Personal Representative:

CHRISTOPHER L. MILLER
2409 Walker Circle
Sarasota, Florida 34234-7447
Attorney for Personal Representative:
R. CRAIG HARRISON, Esq.
E-Mail Address:
craig@lyonsbeaudryharrison.com
E-Mail Address:
ann@lyonsbeaudryharrison.com
Florida Bar No. 0466530
LYONS, BEAUDRY & HARRISON, P.A.
1605 Main Street, Suite 1111
Sarasota, Florida 34236
Telephone: (941) 366-3282
May 23, 30, 2014 14-02338S

FIRST INSERTION

NOTICE TO CREDITORS
IN THE CIRCUIT COURT FOR
SARASOTA COUNTY, FLORIDA
PROBATE DIVISION
File No. 2014CP001968SC
Division Probate
IN RE: ESTATE OF
JACK JOSEPH PIRILLO
Deceased.

The administration of the estate of Jack Joseph Pirillo, deceased, whose date of death was November 8, 2013, is pending in the Circuit Court for Sarasota County, Florida, Probate Division, the address of which is P.O. Box 48927, Sarasota, Florida 34230. The names and addresses of the personal representatives and the personal representatives' attorney are set forth below.

All creditors of the decedent and other persons having claims or demands against decedent's estate on whom a copy of this notice is required to be served must file their claims with this court WITHIN THE LATER OF 3 MONTHS AFTER THE TIME OF THE FIRST PUBLICATION OF THIS NOTICE OR 30 DAYS AFTER THE DATE OF SERVICE OF A COPY OF THIS NOTICE ON THEM.

All other creditors of the decedent and other persons having claims or demands against decedent's estate must file their claims with this court WITHIN 3 MONTHS AFTER THE DATE OF THE FIRST PUBLICATION OF THIS NOTICE.

ALL CLAIMS NOT FILED WITHIN THE TIME PERIODS SET FORTH IN SECTION 733.702 OF THE FLORIDA PROBATE CODE WILL BE FOREVER BARRED.

NOTWITHSTANDING THE TIME PERIODS SET FORTH ABOVE, ANY CLAIM FILED TWO (2) YEARS OR MORE AFTER THE DECEDENT'S DATE OF DEATH IS BARRED.

The date of first publication of this notice is May 23, 2014.

Personal Representatives:
s/ Jacqueline M. Pirillo
Jacqueline M. Pirillo
41 Bergen Drive
Deer Park, New York 11729
s/ Salvatore B. Pirillo
Salvatore B. Pirillo
8 Charter Avenue
Dix Hills, New York 11746

Attorney for Personal Representatives:
s/ Jeffrey M. Backo
Jeffrey M. Backo
Attorney
Florida Bar Number: 0086426
MELLOR & GRISSINGER
13801-D South Tamiami Trail
North Port, FL 34287
Telephone: (941) 426-1193
Fax: (941) 426-5413
E-Mail: jeff@northportlaw.com
Secondary E-Mail:
shelly@northportlaw.com
May 23, 30, 2014 14-02287S

FIRST INSERTION

NOTICE TO CREDITORS
IN THE CIRCUIT COURT FOR
SARASOTA COUNTY, FLORIDA
PROBATE DIVISION
File No. 2014CP001681NC
IN RE: ESTATE OF
WILLIAM G. PFEIL
Deceased.

The administration of the estate of WILLIAM G. PFEIL, deceased, whose date of death was March 27th, 2014, is pending in the Circuit Court for SARASOTA County, Florida, Probate Division, the address of which is P.O. BOX 3079, SARASOTA, FLORIDA 34230. The names and addresses of the personal representative and the personal representative's attorney are set forth below.

All creditors of the decedent and other persons having claims or demands against decedent's estate on whom a copy of this notice is required to be served must file their claims with this court ON OR BEFORE THE LATER OF 3 MONTHS AFTER THE TIME OF THE FIRST PUBLICATION OF THIS NOTICE OR 30 DAYS AFTER THE DATE OF SERVICE OF A COPY OF THIS NOTICE ON THEM.

All other creditors of the decedent and other persons having claims or demands against decedent's estate must file their claims with this court WITHIN 3 MONTHS AFTER THE DATE OF THE FIRST PUBLICATION OF THIS NOTICE.

ALL CLAIMS NOT FILED WITHIN THE TIME PERIODS SET FORTH IN SECTION 733.702 OF THE FLORIDA PROBATE CODE WILL BE FOREVER BARRED.

NOTWITHSTANDING THE TIME PERIODS SET FORTH ABOVE, ANY CLAIM FILED TWO (2) YEARS OR MORE AFTER THE DECEDENT'S DATE OF DEATH IS BARRED.

The date of first publication of this notice is May 23, 2014.

Personal Representative:
KAREN FINER
35 BOCKET STREET
PEARL RIVER, NEW YORK 10965
SANDY ALAN LEVITT, P.A.
Attorneys for Personal Representative
2201 RINGLING BOULEVARD
SUITE 203
SARASOTA, FL 34237
Florida Bar No. 0282529
May 23, 30, 2014 14-02310S

FIRST INSERTION

NOTICE TO CREDITORS
IN THE CIRCUIT COURT FOR
SARASOTA COUNTY, FLORIDA
PROBATE DIVISION
File: 2014-CP-001538-CP
Division Probate
IN RE: ESTATE OF
GEORGE F. HUYER
Deceased.

The administration of the estate of George F. Huyer, deceased, whose date of death was June 16, 2013, is pending in the Circuit Court for Sarasota County, Florida, Probate Division, the address of which is PO Box 3079, Sarasota, Florida 34230. The names and addresses of the personal representative and the personal representative's attorney are set forth below.

All creditors of the decedent and other persons having claims or demands against decedent's estate on whom a copy of this notice is required to be served must file their claims with this court WITHIN THE LATER OF 3 MONTHS AFTER THE TIME OF THE FIRST PUBLICATION OF THIS NOTICE OR 30 DAYS AFTER THE DATE OF SERVICE OF A COPY OF THIS NOTICE ON THEM.

All other creditors of the decedent and other persons having claims or demands against decedent's estate must file their claims with this court WITHIN 3 MONTHS AFTER THE DATE OF THE FIRST PUBLICATION OF THIS NOTICE.

ALL CLAIMS NOT FILED WITHIN THE TIME PERIODS SET FORTH IN SECTION 733.702 OF THE FLORIDA PROBATE CODE WILL BE FOREVER BARRED.

NOTWITHSTANDING THE TIME PERIODS SET FORTH ABOVE, ANY CLAIM FILED TWO (2) YEARS OR MORE AFTER THE DECEDENT'S DATE OF DEATH IS BARRED.

The date of first publication of this notice is May 23, 2014.

Personal Representative:
Father Michael Cronogue
Society of Saint Edmond
270 Winooski Park
Colchester, Vermont 05439

Attorney for Personal Representative:
Charles Diez, Jr.
Florida Bar Number: 019646
Diez & Floyd, P.A.
737 South Indiana Avenue
Suite A
Englewood, FL 34223
Telephone: (941) 474-5506
Fax: (941) 474-5507
E-Mail: diezandfloyd@aol.com
Secondary: diezandfloyd@diezandfloydpa.comcastbiz.net
May 23, 30, 2014 14-02308S

FIRST INSERTION

NOTICE TO CREDITORS
IN THE CIRCUIT COURT FOR
SARASOTA COUNTY, FLORIDA
PROBATE DIVISION
File No. 2014 CP 001935
IN RE: ESTATE OF
BERNICE L. CHILDS
Deceased.

The administration of the estate of Bernice L. Childs, deceased, whose date of death was April 12th, 2014, is pending in the Circuit Court for Sarasota County, Florida, Probate Division, the address of which is P.O. Box 3079 Sarasota, Florida 34236. The names and addresses of the personal representative and the personal representative's attorney are set forth below.

All creditors of the decedent and other persons having claims or demands against decedent's estate on whom a copy of this notice is required to be served must file their claims with this court ON OR BEFORE THE LATER OF 3 MONTHS AFTER THE TIME OF THE FIRST PUBLICATION OF THIS NOTICE OR 30 DAYS AFTER THE DATE OF SERVICE OF A COPY OF THIS NOTICE ON THEM.

All other creditors of the decedent and other persons having claims or demands against decedent's estate must file their claims with this court WITHIN 3 MONTHS AFTER THE DATE OF THE FIRST PUBLICATION OF THIS NOTICE.

ALL CLAIMS NOT FILED WITHIN THE TIME PERIODS SET FORTH IN SECTION 733.702 OF THE FLORIDA PROBATE CODE WILL BE FOREVER BARRED.

NOTWITHSTANDING THE TIME PERIODS SET FORTH ABOVE, ANY CLAIM FILED TWO (2) YEARS OR MORE AFTER THE DECEDENT'S DATE OF DEATH IS BARRED.

The date of first publication of this notice is May 23rd, 2014.

Personal Representative:
Margaret A. Vodnansky
490 N.W. Spring Hollow Blvd.
Lake City, Florida 32055
SHUMAKER, LOOP &
KENDRICK, LLP
Attorneys for Personal Representative
P. O. BOX 49948
SARASOTA, FL 34230
Florida Bar No. 0089559
By: Benjamin R. Hanan, Esquire
May 23, 30, 2014 14-02312S

FIRST INSERTION

NOTICE TO CREDITORS
IN THE CIRCUIT COURT FOR
SARASOTA COUNTY, FLORIDA
PROBATE DIVISION
File No. 2014 CP 001432 SC
IN RE: ESTATE OF
AHMED JAMSHIDI
Deceased.

The ancillary administration of the estate of Ahmed Jamshidi, deceased, whose date of death was December 1, 2013 is pending in the Circuit Court for Sarasota County, Florida, Probate Division, the address of which is P.O. Box 3079, Sarasota, Florida, 34230. The names and addresses of the ancillary personal representative and the ancillary personal representative's attorney are set forth below.

All creditors of the decedent and other persons having claims or demands against decedent's estate on whom a copy of this notice is required to be served must file their claims with this court WITHIN THE LATER OF 3 MONTHS AFTER THE TIME OF THE FIRST PUBLICATION OF THIS NOTICE OR 30 DAYS AFTER THE DATE OF SERVICE OF A COPY OF THIS NOTICE ON THEM.

All other creditors of the decedent and other persons having claims or demands against decedent's estate must file their claims with this court WITHIN 3 MONTHS AFTER THE DATE OF THE FIRST PUBLICATION OF THIS NOTICE.

ALL CLAIMS NOT FILED WITHIN THE TIME PERIODS SET FORTH IN SECTION 733.702 OF THE FLORIDA PROBATE CODE WILL BE FOREVER BARRED.

NOTWITHSTANDING THE TIME PERIODS SET FORTH ABOVE, ANY CLAIM FILED TWO (2) YEARS OR MORE AFTER THE DECEDENT'S DATE OF DEATH IS BARRED.

The date of first publication of this notice is May 23, 2014.

Ancillary Personal Representative:
Faezeh Phillips Jamshidi
51 Strawberry Lane
Shelton, CT 06484

Attorney for Ancillary Personal Representative:
Andrew J. Britton, Esq.
Florida Bar Number: 213500
401 Johnson Lane, Suite 102
Venice, FL 34285
Telephone: (941) 408-8008
Fax: (941) 408-0722
E-Mail: brittonlaw@gmail.com
Secondary E-Mail: FOR SERVICE OF DOCUMENTS
e-service@andrewbrittonlaw.com
May 23, 30, 2014 14-02320S

FIRST INSERTION

NOTICE TO CREDITORS
IN THE CIRCUIT COURT FOR
SARASOTA COUNTY, FLORIDA
PROBATE DIVISION
File No. 2014CP1302
Division Probate
IN RE: ESTATE OF
STEPHEN J. KERLEY, JR.
Deceased.

The administration of the estate of STEPHEN J. KERLEY, JR., deceased, whose date of death was March 16, 2014, is pending in the Circuit Court for Sarasota County, Florida, Probate Division, the address of which is 2000 Main Street, Sarasota, Florida 34237. The names and addresses of the personal representative and the personal representative's attorney are set forth below.

All creditors of the decedent and other persons having claims or demands against decedent's estate on whom a copy of this notice is required to be served must file their claims with this court ON OR BEFORE THE LATER OF 3 MONTHS AFTER THE TIME OF THE FIRST PUBLICATION OF THIS NOTICE OR 30 DAYS AFTER THE DATE OF SERVICE OF A COPY OF THIS NOTICE ON THEM.

All other creditors of the decedent and other persons having claims or demands against decedent's estate must file their claims with this court WITHIN 3 MONTHS AFTER THE DATE OF THE FIRST PUBLICATION OF THIS NOTICE.

ALL CLAIMS NOT FILED WITHIN THE TIME PERIODS SET FORTH IN SECTION 733.702 OF THE FLORIDA PROBATE CODE WILL BE FOREVER BARRED.

NOTWITHSTANDING THE TIME PERIODS SET FORTH ABOVE, ANY CLAIM FILED TWO (2) YEARS OR MORE AFTER THE DECEDENT'S DATE OF DEATH IS BARRED.

The date of first publication of this notice is May 23, 2014.

Personal Representative:
STEPHANIE TIMMONS
23 Breezy Knoll Lane
Lake St. Louis, MO 63367
Attorney for Personal Representative:
Melissa R. Casanueva
FL Bar No. 0105788
6148 State Road 70 East
Bradenton, Florida 34203
Telephone: (941) 756-6600
Email: Melissa@gerlinglawgroup.com
May 23, 30, 2014 14-02309S

FIRST INSERTION

NOTICE TO CREDITORS
IN THE CIRCUIT COURT FOR
SARASOTA COUNTY, FLORIDA
PROBATE DIVISION
File No. 2014CP001766NC
IN RE: ESTATE OF
DEBORAH WATTERSON
SCHROCK, A/K/A DEBORAH H.
SCHROCK
Deceased.

The administration of the estate of DEBORAH WATTERSON SCHROCK A/K/A DEBORAH H. SCHROCK, deceased, whose date of death was February 18, 2014, is pending in the Circuit Court for Sarasota County, Florida, Probate Division, the address of which is P.O. Box 3079, Sarasota, FL 34230. The names and addresses of the personal representative and the personal representative's attorney are set forth below.

All creditors of the decedent and other persons having claims or demands against decedent's estate on whom a copy of this notice is required to be served must file their claims with this court ON OR BEFORE THE LATER OF THREE (3) MONTHS AFTER THE TIME OF THE FIRST PUBLICATION OF THIS NOTICE OR THIRTY (30) DAYS AFTER THE DATE OF SERVICE OF A COPY OF THIS NOTICE ON THEM.

All other creditors of the decedent and other persons having claims or demands against decedent's estate must file their claims with this court WITHIN THREE (3) MONTHS AFTER THE DATE OF THE FIRST PUBLICATION OF THIS NOTICE.

ALL CLAIMS NOT FILED WITHIN THE TIME PERIODS SET FORTH IN SECTION 733.702 OF THE FLORIDA PROBATE CODE WILL BE FOREVER BARRED.

NOTWITHSTANDING THE TIME PERIODS SET FORTH ABOVE, ANY CLAIM FILED TWO (2) YEARS OR MORE AFTER THE DECEDENT'S DATE OF DEATH IS BARRED.

The date of first publication of this notice is: May 23, 2014.

Personal Representative:
Kurtis L. Watterson
10 Schapansky Road
Cochranville, PA 19330

Attorney for Personal Representative:
Richard D. Saba, Esq.
Richard D. Saba, P.A.
Florida Bar No. 175810
2033 Main Street, Suite 303
Sarasota, FL 34237
rsaba@rsabalaw.com
Ph: (941) 952-0990
May 23, 30, 2014 14-02311S

FIRST INSERTION

NOTICE TO CREDITORS
IN THE CIRCUIT COURT FOR
SARASOTA COUNTY, FLORIDA
PROBATE DIVISION
File No. 2013CP004750NC
IN RE: ESTATE OF
REGINA SIENIAWSKI
Deceased.

The administration of the estate of Regina Sieniawski, deceased, whose date of death was September 25, 2013, is pending in the Circuit Court for Sarasota County, Florida, Probate Division, the address of which is 2000 Main Street, Sarasota, Florida 34237. The names and addresses of the personal representative and the personal representative's attorney are set forth below.

All creditors of the decedent and other persons having claims or demands against decedent's estate on whom a copy of this notice is required to be served must file their claims with this court WITHIN THE LATER OF 3 MONTHS AFTER THE TIME OF THE FIRST PUBLICATION OF THIS NOTICE OR 30 DAYS AFTER THE DATE OF SERVICE OF A COPY OF THIS NOTICE ON THEM.

All other creditors of the decedent and other persons having claims or demands against decedent's estate must file their claims with this court WITHIN 3 MONTHS AFTER THE DATE OF THE FIRST PUBLICATION OF THIS NOTICE.

ALL CLAIMS NOT FILED WITHIN THE TIME PERIODS SET FORTH IN SECTION 733.702 OF THE FLORIDA PROBATE CODE WILL BE FOREVER BARRED.

NOTWITHSTANDING THE TIME PERIODS SET FORTH ABOVE, ANY CLAIM FILED TWO (2) YEARS OR MORE AFTER THE DECEDENT'S DATE OF DEATH IS BARRED.

The date of first publication of this notice is May 23, 2014.

Personal Representative:
Krzysztof Owczarek
1364 Piedmont Road
Venice, FL 34293-5361
Attorney for Personal Representative:
Lauren M. Przybyla, Esquire
Florida Bar No.: 89573
PRZYBYLA LAW, P.A.
6605 Superior Avenue
Sarasota, FL 34231
Phone: (941) 448-3077
Facsimile: (941) 893-3355
e-mail: lauren@laurenplaw.com
May 23, 30, 2014 14-02288S

FIRST INSERTION

NOTICE TO CREDITORS
IN THE CIRCUIT COURT FOR
SARASOTA COUNTY, FLORIDA
PROBATE DIVISION
File No. 2014 CP 1300
IN RE: ESTATE OF
HENRY HERMAN HODGSON
Deceased.

The administration of the estate of HENRY HERMAN HODGSON, deceased, whose date of death was March 11, 2014; File Number 2014 CP 1300, is pending in the Circuit Court for Sarasota County, Florida, Probate Division, the address of which is 2000 Main St., Sarasota, FL 34236. The names and addresses of the personal representative and the personal representative's attorney are set forth below.

All creditors of the decedent and other persons having claims or demands against decedent's estate, on whom a copy of this notice is required to be served must file their claims with this court ON OR BEFORE THE LATER OF 3 MONTHS AFTER THE TIME OF THE FIRST PUBLICATION OF THIS NOTICE OR 30 DAYS AFTER THE DATE OF SERVICE OF A COPY OF THIS NOTICE ON THEM.

All other creditors of the decedent and other persons having claims or demands against decedent's estate must file their claims with this court WITHIN 3 MONTHS AFTER THE DATE OF THE FIRST PUBLICATION OF THIS NOTICE.

ALL CLAIMS NOT FILED WITHIN THE TIME PERIODS SET FORTH IN SECTION 733.702 OF THE FLORIDA PROBATE CODE WILL BE FOREVER BARRED.

NOTWITHSTANDING THE TIME PERIOD SET FORTH ABOVE, ANY CLAIM FILED TWO (2) YEARS OR MORE AFTER THE DECEDENT'S DATE OF DEATH IS BARRED.

The date of first publication of this notice is: May 23, 2014.

**ELISSA WYATT HODGSON
Personal Representative**
1358 Landings Blvd
Sarasota, FL 34236

John J. Waskom
Attorney for Personal Representative
Email: jwaskom@icardmerrill.com
Secondary Email:
swade@icardmerrill.com
Florida Bar No. 0962181
ICARD, MERRILL, CULLIS, TIMM,
FUREN & GINSBURG, P.A.
2033 Main St., Ste. 500
Sarasota, FL 34237
Telephone: 941-366-8100
941-366-5263
May 23, 30, 2014 14-02265S

FIRST INSERTION

NOTICE TO CREDITORS
IN THE CIRCUIT COURT FOR
SARASOTA COUNTY, FLORIDA
PROBATE DIVISION
File No. 2014 CP 1358 NC
IN RE: ESTATE OF
BARBARA SARKIN
Deceased.

The administration of the estate of BARBARA SARKIN, deceased, whose date of death was December 23, 2013, is pending in the Circuit Court for Sarasota County, Florida, Probate Division, the address of which is 2000 Main Street, Sarasota, Florida 34237. The names and addresses of the personal representative and the personal representative's attorney are set forth below.

All creditors of the decedent and other persons having claims or demands against decedent's estate on whom a copy of this notice is required to be served must file their claims with this court WITHIN THE LATER OF 3 MONTHS AFTER THE TIME OF THE FIRST PUBLICATION OF THIS NOTICE OR 30 DAYS AFTER THE DATE OF SERVICE OF A COPY OF THIS NOTICE ON THEM.

All other creditors of the decedent and other persons having claims or demands against decedent's estate must file their claims with this court WITHIN 3 MONTHS AFTER THE DATE OF THE FIRST PUBLICATION OF THIS NOTICE.

ALL CLAIMS NOT FILED WITHIN THE TIME PERIODS SET FORTH IN SECTION 733.702 OF THE FLORIDA PROBATE CODE WILL BE FOREVER BARRED.

NOTWITHSTANDING THE TIME PERIODS SET FORTH ABOVE, ANY CLAIM FILED TWO (2) YEARS OR MORE AFTER THE DECEDENT'S DATE OF DEATH IS BARRED.

The date of first publication of this notice is May 23, 2014.

Personal Representative:
KARMY PERETZ
2523 Riverbluff Parkway
Sarasota, Florida 34231
Attorney for Personal Representative:
WILLIAM H. BEHRENFELD
Attorney
Florida Bar Number: 302414
1800 Second Street, Suite 790
P.O. Box 4217
Sarasota, FL 34230-4217
Telephone: (941) 365-7887
Fax: (941) 365-9094
E-Mail: w.behrenfeld@verizon.net
May 23, 30, 2014 14-02267S

FIRST INSERTION

NOTICE TO CREDITORS
IN THE CIRCUIT COURT FOR
SARASOTA COUNTY, FLORIDA
PROBATE DIVISION
File No. 2014 CP 1667 NC
Division: Probate
IN RE: ESTATE OF
JOHN JOSEPH SENNINGER,
Deceased.

The administration of the estate of John Joseph Senninger, deceased, whose date of death was March 27, 2014, is pending in the Circuit Court for Sarasota County, Florida, Probate Division, the address of which is P.O. Box 3079, Sarasota, Florida 34230-3079. The names and addresses of the personal representative and the personal representative's attorney are set forth below.

All creditors of the decedent and other persons having claims or demands against decedent's estate, on whom a copy of this notice is required to be served must file their claims with this court WITHIN THE LATER OF 3 MONTHS AFTER THE TIME OF THE FIRST PUBLICATION OF THIS NOTICE OR 30 DAYS AFTER THE DATE OF SERVICE OF A COPY OF THIS NOTICE ON THEM.

All other creditors of the decedent and other persons having claims or demands against decedent's estate must file their claims with this court WITHIN 3 MONTHS AFTER THE DATE OF THE FIRST PUBLICATION OF THIS NOTICE.

ALL CLAIMS NOT FILED WITHIN THE TIME PERIODS SET FORTH IN SECTION 733.702 OF THE FLORIDA PROBATE CODE WILL BE FOREVER BARRED.

NOTWITHSTANDING THE TIME PERIODS SET FORTH ABOVE, ANY CLAIM FILED TWO (2) YEARS OR MORE AFTER THE DECEDENT'S DATE OF DEATH IS BARRED.

The date of first publication of this notice is May 23, 2014.

Personal Representative:
Jean A. Senninger
2729 Riverbluff Place, #54
Sarasota, Florida 34231

Attorney for Personal Representative:
Bradley D. Magee, Esq.
Attorney for Jean A. Senninger
Florida Bar No. 861730
BRADLEY D. MAGEE, ATTORNEY
AT LAW, P.L.
P.O. Box 3
Osprey, FL 34229
Telephone: (941) 918-9894
Email: magee-law@comcast.net
May 23, 30, 2014 14-02285S

FIRST INSERTION

NOTICE TO CREDITORS
IN THE CIRCUIT COURT FOR
SARASOTA COUNTY, FLORIDA
PROBATE DIVISION
File No. 2014-CP-001892-NC
Division Probate
IN RE: ESTATE OF
ROLF M. STERNBERG,
Deceased.

The administration of the estate of Rolf M. Sternberg, whose date of death was November 29, 2012, and whose social security number is XXX-XX-4824, File No 2014-CP-001892-NC, is pending in the Circuit Court for Sarasota County, Florida, Probate Division, the address of which is 2002 Ringling Boulevard, Sarasota Florida 34237. The names and addresses of the personal representative and the personal representative's attorney are set forth below.

All creditors of the decedent and other persons having claims or demands against decedent's estate on whom a copy of this notice is required to be served must file their claims with this court WITHIN THE LATER OF 3 MONTHS AFTER THE TIME OF THE FIRST PUBLICATION OF THIS NOTICE OR 30 DAYS AFTER THE DATE OF SERVICE OF A COPY OF THIS NOTICE ON THEM.

All other creditors of the decedent and other persons having claims or demands against decedent's estate must file their claims with this court WITHIN 3 MONTHS AFTER THE DATE OF THE FIRST PUBLICATION OF THIS NOTICE.

ALL CLAIMS NOT FILED WITHIN THE TIME PERIODS SET FORTH IN SECTION 733.702 OF THE FLORIDA PROBATE CODE WILL BE FOREVER BARRED.

NOTWITHSTANDING THE TIME PERIODS SET FORTH ABOVE, ANY CLAIM FILED TWO (2) YEARS OR MORE AFTER THE DECEDENT'S DATE OF DEATH IS BARRED.

The date of first publication of this notice is May 23, 2014.

Personal Representative:
Shira A. Sternberg
608 Tremont Street, Unit #5
Boston, MA 02118
Attorney for Personal Representative:
Elliott L. Dozier
Florida Bar No. 0730602
Dozier & Dozier
2407 Fruitville Road
Sarasota, Florida 34237
Telephone: (941) 953-5797
May 23, 30, 2014 14-02286S

FIRST INERTION

RE-NOTICE OF FORECLOSURE SALE IN THE CIRCUIT COURT OF THE TWELFTH JUDICIAL CIRCUIT, IN AND FOR SARASOTA COUNTY, FLORIDA

CIVIL DIVISION
CASE NO.: 2009 CA 000767 NC
PNC BANK, NATIONAL ASSOCIATION, SUCCESSOR BY MERGER TO NATIONAL CITY MORTGAGE, A DIVISION OF NATIONAL CITY BANK, SUCCESSOR BY MERGER TO NATIONAL CITY BANK OF

FIRST INSERTION

RE-NOTICE OF FORECLOSURE SALE IN THE CIRCUIT COURT OF THE TWELFTH JUDICIAL CIRCUIT, IN AND FOR SARASOTA COUNTY, FLORIDA

CIVIL DIVISION
CASE NO.: 2013 CA 003045 NC
JPMORGAN CHASE BANK, NATIONAL ASSOCIATION Plaintiff, vs. JEREMIAH GAERTNER, et al

RE-NOTICE IS HEREBY GIVEN pursuant to an Order Granting Plaintiff's Motion to Reschedule Foreclosure Sale filed May 16, 2014 and entered in Case No. 2013 CA 003045 NC of the Circuit Court of the TWELFTH Judicial Circuit in and for SARASOTA COUNTY, Florida, wherein JPMORGAN CHASE BANK, NATIONAL ASSOCIATION, is Plaintiff, and JEREMIAH GAERTNER, et al are Defendants, the clerk will sell to the highest and best bidder for cash, beginning at 09:00 AM at www.sarasota.realforeclose.com, in accordance with Chapter 45, Florida Statutes, on the 20 day of June, 2014, the following described property as set forth in said Lis Pendens, to wit:

THE SOUTH 32.5 FEET OF THE WEST 90 FEET OF LOT 25 AND THE WEST 90 FEET OF LOTS 27 AND 29, BLOCK 5, FLORA VILLA SUBDIVISION, AS PER PLAT THEREOF RECORDED IN PLAT BOOK 2, PAGE 5, OF THE PUBLIC RECORDS OF SARASOTA COUNTY, FLORIDA.

Any person claiming an interest in the surplus funds from the sale, if any, other than the property owner as of the date of the lis pendens must file a claim within 60 days after the sale.

If you are a person with a disability who needs any accommodation in order to participate in this proceeding, you are entitled, at no cost to you, to the provision of certain assistance. Please contact the Sarasota County Jury Office, P.O. Box 3079, Sarasota, Florida 34230-3079, (941)861-7400, at least seven (7) days before your scheduled court appearance, or immediately upon receiving this notification if the time before the scheduled appearance is less than seven (7) days; if you are hearing or voice impaired, call 711.

Dated: May 20, 2014

By: /s/ Heather J. Koch
Phelan Hallinan, PLC
Heather J. Koch, Esq.,
Florida Bar No. 89107
Emilio R. Lenzi, Esq.,
Florida Bar No. 0668273

Phelan Hallinan, PLC
Attorneys for Plaintiff
2727 West Cypress Creek Road
Ft. Lauderdale, FL 33309
Tel: 954-462-7000
Fax: 954-462-7001
Service by email:
FL.Service@PhelanHallinan.com
PH # 39417
May 23, 30, 2014 14-02331S

INDIANA Plaintiff, vs. HOLLY A. REX, et al
Defendants.
RE-NOTICE IS HEREBY GIVEN pursuant to an Order Granting Plaintiff's Motion to Reschedule Foreclosure Sale filed May 9, 2014 and entered in Case No. 2009 CA 000767 NC of the Circuit Court of the TWELFTH Judicial Circuit in and for SARASOTA COUNTY, Florida, wherein PNC BANK, NATIONAL ASSOCIATION, SUCCESSOR BY MERGER TO NATIONAL CITY

FIRST INSERTION

NOTICE OF FORECLOSURE SALE IN THE CIRCUIT COURT OF THE TWELFTH JUDICIAL CIRCUIT IN AND FOR SARASOTA COUNTY, FLORIDA

CIVIL ACTION
CASE NO.: 58-2009-CA-020713 NC
DIVISION: C
WELLS FARGO BANK, NA, Plaintiff, vs. STEPHEN A. PALMER, et al, Defendant(s).

NOTICE IS HEREBY GIVEN pursuant to a Final Judgment of Mortgage Foreclosure dated April 21, 2014 and entered in Case No. 58-2009-CA-020713 NC of the Circuit Court of the TWELFTH Judicial Circuit in and for SARASOTA COUNTY, Florida wherein WELLS FARGO BANK, NA is the Plaintiff and STEPHEN A. PALMER; DONALD H. PADGETT; JOAN B. PADGETT A/K/A JO ANN B. PADGETT; CEDAR HAMMOCK OWNERS' ASSOCIATION, INC.; UNITED STATES OF AMERICA; are the Defendants. The Clerk will sell to the highest and best bidder for cash at WWW.SARASOTA.REALFORECLOSE.COM at 9:00AM, on the 18th day of September, 2014, the following described property as set forth in said Final Judgment:

THE NORTHERLY 37.40 FEET OF LOT 6, BLOCK C, CEDAR HAMMOCK, A SUBDIVISION ACCORDING TO THE PLAT THEREOF, AS RECORDED IN PLAT BOOK 28, PAGES 21-21D, OF THE PUBLIC RECORDS OF SARASOTA COUNTY, FLORIDA.

A/K/A 5191 CEDAR HAMMOCK LANE, SARASOTA, FL 34232

Any person claiming an interest in the surplus from the sale, if any, other than the property owner as of the date of the Lis Pendens must file a claim within sixty (60) days after the sale.

If you are a person with a disability who needs any accommodation in order to participate in this proceeding, you are entitled, at no cost to you, to the provision of certain assistance. Please contact the Sarasota County Jury Office, P.O. Box 3079, Sarasota, Florida 34230-3079, (941)861-7400, at least seven (7) days before your scheduled court appearance, or immediately upon receiving this notification if the time before the scheduled appearance is less than seven (7) days; if you are hearing or voice impaired, call 711.

By: Matthew Wolf

Florida Bar No. 92611
Ronald R Wolfe & Associates, P.L.
P.O. Box 25018
Tampa, Florida 33622-5018
(813) 251-4766
(813) 251-1541 Fax
F09118273
May 23, 30, 2014 14-02262S

MORTGAGE, A DIVISION OF NATIONAL CITY BANK, SUCCESSOR BY MERGER TO NATIONAL CITY BANK OF INDIANA, is Plaintiff, and HOLLY A. REX, et al are Defendants, the clerk will sell to the highest and best bidder for cash, beginning at 09:00 AM at www.sarasota.realforeclose.com, in accordance with Chapter 45, Florida Statutes, on the 13 day of June, 2014, the following described property as set forth in said Lis Pendens, to wit:

Lot 1, Block 1517, 30th ADDI-

FIRST INSERTION

NOTICE OF FORECLOSURE SALE IN THE CIRCUIT COURT OF THE TWELFTH JUDICIAL CIRCUIT IN AND FOR SARASOTA COUNTY, FLORIDA

CIVIL ACTION
CASE NO.: 58-2013-CA-008133 NC
DIVISION: C
JPMORGAN CHASE BANK, NATIONAL ASSOCIATION, Plaintiff, vs. EDWARD M. GRADY, JR., et al, Defendant(s).

NOTICE IS HEREBY GIVEN pursuant to a Final Judgment of Mortgage Foreclosure dated May 12, 2014 and entered in Case No. 58-2013-CA-008133 NC of the Circuit Court of the TWELFTH Judicial Circuit in and for SARASOTA COUNTY, Florida wherein JPMORGAN CHASE BANK, NATIONAL ASSOCIATION is the Plaintiff and EDWARD M. GRADY, JR.; THE UNKNOWN SPOUSE OF EDWARD M. GRADY, JR. N/K/A AMY BRYAN; JOCKEY CLUB OF NORTH PORT PROPERTY OWNERS' ASSOCIATION, INC.; are the Defendants. The Clerk will sell to the highest and best bidder for cash at WWW.SARASOTA.REALFORECLOSE.COM at 9:00AM, on the 9th day of September, 2014, the following described property as set forth in said Final Judgment:

LOT 12, BLOCK 2632, FIFTY-SECOND ADDITION TO PORT CHARLOTTE SUBDIVISION, A SUBDIVISION ACCORDING TO THE PLAT THEREOF, AS RECORDED IN PLAT BOOK 21, PAGE 13, 13A-13NN, OF THE PUBLIC RECORDS OF SARASOTA COUNTY, FLORIDA.

A/K/A 6857 KETONA ROAD, NORTHPORT, FL 34287

Any person claiming an interest in the surplus from the sale, if any, other than the property owner as of the date of the Lis Pendens must file a claim within sixty (60) days after the sale.

If you are a person with a disability who needs any accommodation in order to participate in this proceeding, you are entitled, at no cost to you, to the provision of certain assistance. Please contact the Sarasota County Jury Office, P.O. Box 3079, Sarasota, Florida 34230-3079, (941)861-7400, at least seven (7) days before your scheduled court appearance, or immediately upon receiving this notification if the time before the scheduled appearance is less than seven (7) days; if you are hearing or voice impaired, call 711.

By: Victoria S. Jones

Florida Bar No. 52252
Ronald R Wolfe & Associates, P.L.
P.O. Box 25018
Tampa, Florida 33622-5018
(813) 251-4766
(813) 251-1541 Fax
F13015212
May 23, 30, 2014 14-02260S

TION TO PORT CHARLOTTE SUBDIVISION, according to the Plat thereof recorded in Plat Book 15 Pages 14, 14A thru 14Q of the Public Records of Sarasota County, Florida.

Any person claiming an interest in the surplus funds from the sale, if any, other than the property owner as of the date of the lis pendens must file a claim within 60 days after the sale.

If you are a person with a disability who needs any accommodation in order to participate in

FIRST INSERTION

NOTICE OF SALE IN THE CIRCUIT CIVIL COURT OF THE TWELFTH JUDICIAL CIRCUIT OF FLORIDA, IN AND FOR SARASOTA COUNTY CIVIL DIVISION

Case No. 58-2013-CA-004611-NC
Division A
JPMC SPECIALTY MORTGAGE LLC F/K/A WM SPECIALTY MORTGAGE LLC Plaintiff, vs. THOMAS E. RUGGIERI, PATRICIA L. RUGGIERI, ACCUTECH RESTORATION & REMODELING, INC. AND UNKNOWN TENANTS/OWNERS, Defendants.

Notice is hereby given, pursuant to Final Judgment of Foreclosure for Plaintiff entered in this cause on May 12, 2014, in the Circuit Court of Sarasota County, Florida, The Clerk of the Court will sell the property situated in Sarasota County, Florida described as:

LOT 4, BLOCK 1750, 34TH ADDITION TO PORT CHARLOTTE SUBDIVISION, ACCORDING TO THE PLAT THEREOF RECORDED IN PLAT BOOK 15, PAGE 18, OF THE PUBLIC RECORDS OF SARASOTA COUNTY, FLORIDA.

and commonly known as: 3362 FERGUS STREET, NORTH PORT, FL 34288; including the building, appurtenances, and fixtures located therein, at public sale, to the highest and best bidder, for cash, Sales are held online at: https://www.sarasota.realforeclose.com, on June 16, 2014 at 9:00 A.M.

Any person claiming an interest in the surplus from the sale, if any, other than the property owner as of the date of the lis pendens must file a claim within 60 days after the sale.

If you are a person with a disability who needs any accommodation in order to participate in this proceeding, you are entitled, at no cost to you, to the provision of certain assistance. Please contact the Sarasota County Jury Office, P.O. Box 3079, Sarasota, Florida 34230-3079, (941)861-7400, at least seven (7) days before your scheduled court appearance, or immediately upon receiving this notification if the time before the scheduled appearance is less than seven (7) days; if you are hearing or voice impaired, call 711.

Karen E. Rushing

By: Frances Grace Cooper, Esquire
Attorney for Plaintiff

Edward B. Pritchard
(813) 229-0900 x1309
Kass Shuler, P.A.
P.O. Box 800
Tampa, FL 33601-0800
ForeclosureService@kasslaw.com
327498/1120536/
May 23, 30, 2014 14-02316S

this proceeding, you are entitled, at no cost to you, to the provision of certain assistance. Please contact the Sarasota County Jury Office, P.O. Box 3079, Sarasota, Florida 34230-3079, (941)861-7400, at least seven (7) days before your scheduled court appearance, or immediately upon receiving this notification if the time before the scheduled appearance is less than seven (7) days; if you are hearing or voice impaired, call 711.

Dated: May 20, 2014

By: /s/ Heather J. Koch

FIRST INSERTION

NOTICE OF FORECLOSURE SALE IN THE CIRCUIT COURT OF THE TWELFTH JUDICIAL CIRCUIT IN AND FOR SARASOTA COUNTY, FLORIDA

CIVIL ACTION
CASE NO.: 2013 CA 008269 NC
DIVISION: A
WELLS FARGO BANK, N.A., Plaintiff, vs. KEITH M. CUMMINGS, et al, Defendant(s).

NOTICE IS HEREBY GIVEN pursuant to a Final Judgment of Mortgage Foreclosure dated May 12, 2014 and entered in Case No. 2013 CA 008269 NC of the Circuit Court of the TWELFTH Judicial Circuit in and for SARASOTA COUNTY, Florida wherein WELLS FARGO BANK, N.A. is the Plaintiff and KEITH M. CUMMINGS; SANDRA J. CUMMINGS; UNITED STATES OF AMERICA-INTERNAL REVENUE SERVICE; are the Defendants. The Clerk will sell to the highest and best bidder for cash at WWW.SARASOTA.REALFORECLOSE.COM at 9:00AM, on the 17th day of June, 2014, the following described property as set forth in said Final Judgment:

LOT 16, BLOCK 501, ELEVENTH ADDITION TO PORT CHARLOTTE SUBDIVISION, ACCORDING TO THE PLAT THEREOF, AS RECORDED IN PLAT BOOK 13, PAGE 2 AND 2A THROUGH 2I, OF THE PUBLIC RECORDS OF SARASOTA COUNTY, FLORIDA.

A/K/A 3619 COQUINA AVENUE, NORTH PORT, FL 34286-7436

Any person claiming an interest in the surplus from the sale, if any, other than the property owner as of the date of the Lis Pendens must file a claim within sixty (60) days after the sale.

If you are a person with a disability who needs any accommodation in order to participate in this proceeding, you are entitled, at no cost to you, to the provision of certain assistance. Please contact the Sarasota County Jury Office, P.O. Box 3079, Sarasota, Florida 34230-3079, (941)861-7400, at least seven (7) days before your scheduled court appearance, or immediately upon receiving this notification if the time before the scheduled appearance is less than seven (7) days; if you are hearing or voice impaired, call 711.

By: Matthew Wolf

Florida Bar No. 92611
Ronald R Wolfe & Associates, P.L.

P.O. Box 25018
Tampa, Florida 33622-5018
(813) 251-4766
(813) 251-1541 Fax
F13011858
May 23, 30, 2014 14-02245S

FIRST INERTION

NOTICE OF FORECLOSURE SALE IN THE CIRCUIT COURT IN AND FOR SARASOTA COUNTY, FLORIDA

CASE NO: 2008 CA 006782 SC
THE BANK OF NEW YORK AS TRUSTEE FOR THE CERTIFICATEHOLDERS CWALT, INC. ALTERNATIVE LOAN TRUST 2005-1ICB MORTGAGE Plaintiff, vs. CHRISTOPHER MCPHERSON A/K/A CHRISTOPHER I. MCPHERSON; TIANJIAO MCPHERSON A/K/A TIANJIANO MCPHERSON; ANY AND ALL UNKNOWN PARTIES CLAIMING BY, THROUGH, UNDER, AND AGAINST THE HEREIN NAMED INDIVIDUAL DEFENDANT(S) WHO ARE NOT KNOWN TO BE DEAD OR ALIVE, WHETHER SAID UNKNOWN PARTIES MAY CLAIM AN INTEREST AS SPOUSES, HEIRS, DEVISEES, GRANTEES OR OTHER CLAIMANTS; CTM PROPERTIES, LLC AS TRUSTEE UNDER THE TRUST AGREEMENT DATED JANUARY 1, 2006, Defendants.

NOTICE is hereby given that the Clerk of the Circuit Court of Sarasota County, Florida, will on the 19th day of June 2014, at 9:00 a.m. at www.sarasota.realforeclose.com, offer for sale and sell at public outcry to the highest and best bidder for cash, the following-described property situate in Sarasota County, Florida:

LOT 22, BLOCK 171, 2ND ADDITION TO PORT CHARLOTTE SUBDIVISION, ACCORDING

Phelan Hallinan, PLC
Heather J. Koch, Esq.,
Florida Bar No. 89107
Emilio R. Lenzi, Esq.,
Florida Bar No. 0668273

Phelan Hallinan, PLC
Attorneys for Plaintiff
2727 West Cypress Creek Road
Ft. Lauderdale, FL 33309
Tel: 954-462-7000
Fax: 954-462-7001
Service by email:
FL.Service@PhelanHallinan.com
PH # 46434
May 23, 30, 2014 14-02332S

FIRST INSERTION

NOTICE OF SALE IN THE CIRCUIT CIVIL COURT OF THE TWELFTH JUDICIAL CIRCUIT OF FLORIDA, IN AND FOR SARASOTA COUNTY CIVIL DIVISION

Case No. 58-2013-CA-001693 NC
Division A
U.S. BANK NATIONAL ASSOCIATION, AS TRUSTEE FOR HOMEBCANC MORTGAGE TRUST 2005-3 MORTGAGE BACKED NOTES, SERIES 2005-3 Plaintiff, vs. CHARLES T. BRADEN AND UNKNOWN TENANTS/OWNERS, Defendants.

Notice is hereby given, pursuant to Final Judgment of Foreclosure for Plaintiff entered in this cause on May 12, 2014, in the Circuit Court of Sarasota County, Florida, The Clerk of the Court will sell the property situated in Sarasota County, Florida described as:

LOT 29, BLOSSOM BROOK, ACCORDING TO THE PLAT THEREOF RECORDED IN PLAT BOOK 9, PAGE 20, OF THE PUBLIC RECORDS OF SARASOTA COUNTY, FLORIDA.

and commonly known as: 2238 GROVE ST, SARASOTA, FL 34239; including the building, appurtenances, and fixtures located therein, at public sale, to the highest and best bidder, for cash, Sales are held online at: https://www.sarasota.realforeclose.com, on June 16, 2014 at 9:00 A.M.

Any person claiming an interest in the surplus from the sale, if any, other than the property owner as of the date of the lis pendens must file a claim within 60 days after the sale.

If you are a person with a disability who needs any accommodation in order to participate in this proceeding, you are entitled, at no cost to you, to the provision of certain assistance. Please contact the Sarasota County Jury Office, P.O. Box 3079, Sarasota, Florida 34230-3079, (941)861-7400, at least seven (7) days before your scheduled court appearance, or immediately upon receiving this notification if the time before the scheduled appearance is less than seven (7) days; if you are hearing or voice impaired, call 711.

Karen E. Rushing

By: Frances Grace Cooper, Esquire
Attorney for Plaintiff

Edward B. Pritchard
(813) 229-0900 x1309
Kass Shuler, P.A.
P.O. Box 800
Tampa, FL 33601-0800
ForeclosureService@kasslaw.com
320400/1132813/
May 23, 30, 2014 14-02317S

FIRST INERTION

RE-NOTICE OF SALE IN THE CIRCUIT COURT OF THE TWELFTH JUDICIAL CIRCUIT, IN AND FOR SARASOTA COUNTY, FLORIDA

CASE NO. 2007-CA-011949-SC
US BANK NATIONAL ASSOCIATION, AS TRUSTEE FOR SG MORTGAGE SECURITIES TRUST 2006-FRE2, ASSET BACKED CERTIFICATES, SERIES 2006-FRE2; Plaintiff, vs. JOHN T. ALLAIRE, ET AL; Defendants

NOTICE IS HEREBY GIVEN pursuant to an Order rescheduling foreclosure sale dated MAY 05, 2014 entered in Civil Case No. 2007-CA-011949-SC of the Circuit Court of the TWELFTH Judicial Circuit in and for Sarasota County, Florida, wherein US BANK NATIONAL ASSOCIATION, AS TRUSTEE FOR SG MORTGAGE SECURITIES TRUST 2006-FRE2, ASSET BACKED CERTIFICATES, SERIES 2006-FRE2, Plaintiff and JOHN T. ALLAIRE, ET AL, are defendant(s). The Clerk will sell to the highest and best bidder for cash, AT www.sarasota.realforeclose.com, IN ACCORDANCE WITH CHAPTER 45, FLORIDA STATUTES, AT 9:00 AM, JUNE 12, 2014 the following described property as set forth in said Final Judgment, to-wit:

LOT 1, OF SPANISH WELLS, A REPLAT OF LOTS 812 AND 813 OF ENGLEWOOD GARDENS, NO. 3 ACCORDING TO THE PLAT THEREOF, AS RECORDED IN PLAT BOOK

28, PAGE 34, OF THE PUBLIC RECORDS OF SARASOTA COUNTY, FLORIDA

Property Address: 802 DIANE CR., ENGLEWOOD, FL 34223
ANY PERSON CLAIMING AN INTEREST IN THE SURPLUS FROM THE SALE, IF ANY, OTHER THAN THE PROPERTY OWNER AS OF THE DATE OF THE LIS PENDENS MUST FILE A CLAIM WITHIN 60 DAYS AFTER THE SALE.

If you are a person with a disability who needs any accommodation in order to participate in this proceeding, you are entitled, at no cost to you, to the provision of certain assistance. Please contact the Sarasota County Jury Office, P.O. Box 3079, Sarasota, Florida 34230-3079, (941)861-7400, at least seven (7) days before your scheduled court appearance, or immediately upon receiving this notification if the time before the scheduled appearance is less than seven (7) days; if you are hearing or voice impaired, call 711.

DATED at Sarasota, Florida, this 20 day of May, 2014.

By: Jessica M. Aldeguer, Esq.
FBN. 100678

Attorneys for Plaintiff
Marinoci Law Group, P.C.
100 West Cypress Creek Road,
Suite 1045
Fort Lauderdale, FL 33309
Phone: (954)-644-8704;
Fax (954) 772-9601
ServiceFL@mlg-defaultlaw.com
ServiceFL2@mlg-defaultlaw.com
10-12001
May 23, 30, 2014 14-02324S

FIRST INERTION

RE-NOTICE OF FORECLOSURE SALE IN THE CIRCUIT COURT OF THE TWELFTH JUDICIAL CIRCUIT, IN AND FOR SARASOTA COUNTY, FLORIDA

CIVIL DIVISION
CASE NO.: 2012 CA 006737 NC
JPMORGAN CHASE BANK, NATIONAL ASSOCIATION, SUCCESSOR IN INTEREST BY PURCHASE FROM THE FEDERAL DEPOSIT INSURANCE CORPORATION AS RECEIVER OF WASHINGTON MUTUAL BANK F/K/A WASHINGTON MUTUAL BANK, FA Plaintiff, vs. ROY WALTER KELLOGG, IV, et al Defendants.

RE-NOTICE IS HEREBY GIVEN pursuant to an Order Granting Plaintiff's Motion to Reschedule Foreclosure Sale filed May 9, 2014 and entered in Case No. 2012 CA 006737 NC of the Circuit Court of the TWELFTH Judicial Circuit in and for SARASOTA COUNTY, Florida, wherein JPMORGAN CHASE BANK, NATIONAL ASSOCIATION, SUCCESSOR IN INTEREST BY PURCHASE FROM THE FEDERAL DEPOSIT INSURANCE CORPORATION AS RECEIVER OF WASHINGTON MUTUAL BANK F/K/A WASHINGTON MUTUAL BANK, FA, is Plaintiff, and ROY WALTER KELLOGG, IV, et al are Defendants, the clerk will sell to the highest and best bidder for cash, beginning at 09:00 AM at www.sarasota.realforeclose.com, in accordance with Chapter 45, Florida Statutes, on the 13 day of June, 2014, the following described property

as set forth in said Lis Pendens, to wit: Lot 5, Block 464 of 8th ADDITION TO PORT CHARLOTTE SUBDIVISION, a Subdivision according to the Plat thereof, as recorded in Plat Book 12, Page 20, of the Public Records of Sarasota County, Florida.

Any person claiming an interest in the surplus funds from the sale, if any, other than the property owner as of the date of the lis pendens must file a claim within 60 days after the sale.

If you are a person with a disability who needs any accommodation in order to participate in this proceeding, you are entitled, at no cost to you, to the provision of certain assistance. Please contact the Sarasota County Jury Office, P.O. Box 3079, Sarasota, Florida 34230-3079, (941)861-7400, at least seven (7) days before your scheduled court appearance, or immediately upon receiving this notification if the time before the scheduled appearance is less than seven (7) days; if you are hearing or voice impaired, call 711.

Dated: May 19, 2014

By: /s/ Heather Griffiths
Phelan Hallinan, PLC
Heather Griffiths, Esq.,
Florida Bar No. 0091444
Emilio R. Lenzi, Esq.,
Florida Bar No. 0668273

Phelan Hallinan, PLC
Attorneys for Plaintiff
2727 West Cypress Creek Road
Ft. Lauderdale, FL 33309
Tel: 954-462-7000
Fax: 954-462-7001
Service by email:
FL.Service@PhelanHallinan.com
May 23, 30, 2014 14-02302S

TO THE PLAT THEREOF RECORDED IN PLAT BOOK 11, PAGE 30, OF THE PUBLIC RECORDS OF SARASOTA COUNTY, FLORIDA

pursuant to the Final Judgment entered in a case pending in said Court, the style of which is indicated above.

Any person or entity claiming an interest in the surplus, if any, resulting from the foreclosure sale, other than the property owner as of the date of the Lis Pendens, must file a claim on same with the Clerk of Court within 60 days after the foreclosure sale.

If you are a person with a disability who needs any accommodation in order to participate in this proceeding, you are entitled, at no cost to you, to the provision of certain assistance. Please contact the Sarasota County Jury Office, P.O. Box 3079, Sarasota, Florida 34230-3079, (941)861-7400, at least seven (7) days before your scheduled court appearance, or immediately upon receiving this notification if the time before the scheduled appearance is less than seven (7) days; if you are hearing or voice impaired, call 711.

DATED this 19th day of May, 2014

John J. Bennett
Florida Bar Number: 98257
Brandon R. McDowell, Esquire
Florida Bar No: 0072170

BUTLER & HOSCH, P.A.
Mailing Address:
3185 South Conway Road, Suite E
Orlando, Florida 32812
Telephone: (407) 381-5200
Fax: (407) 381-5577
Attorney for Plaintiff
Service of Pleadings Email:
FL.Pleadings@butlerandhosch.com
B&H # 291768
May 23, 30, 2014 14-02330S

FIRST INSERTION

NOTICE OF APPLICATION FOR TAX DEED

Notice is hereby given that CITRUS CAPITAL LLC - SERIES 44 US BANK % CITRUS CAPITAL LLC -, the holder of the certificate listed below, has filed said certificate for a tax deed to be issued. The certificate number and year of issuance, the description of the property, and the names in which the property is assessed are as follows:

Certificate Number: 11068.000
Year of Issuance: 2012
Tax Deed File #: 14-0050 TD

Description of Property: 1152236503 LOT 3 BLK 2365 48TH ADD TO PORT CHARLOTTE

Name in which the property is assessed: EZEKIEL WALKER

All of said property being in the County of Sarasota, State of Florida. Unless the certificate is redeemed according to law, the property described in the certificate will be sold to the highest bidder at the Sarasota County Court House, 2000 Main Street, Historic Courtroom, East Wing, Sarasota, Florida, at 9:00 a.m. on the 24TH day of JUNE, 2014.

Karen E. Rushing
Clerk Of The Circuit Court
Sarasota County, Florida
By: T. Lake, Deputy Clerk
Publication Dates: MAY 23, 30; JUNE 6, 13, 2014

14-02268S

FIRST INSERTION

NOTICE OF APPLICATION FOR TAX DEED

Notice is hereby given that ERIKA GINSBERG KLEMMT, the holder of the certificate listed below, has filed said certificate for a tax deed to be issued. The certificate number and year of issuance, the description of the property, and the names in which the property is assessed are as follows:

Certificate Number: 11249.000
Year of Issuance: 2012
Tax Deed File #: 14-0056 TD

Description of Property: 2020020001 LOT 1, BLK F, AMARYLLIS PARK, CORR ORI 2007092044

Name in which the property is assessed: PARADISE OF SARASOTA INC

All of said property being in the County of Sarasota, State of Florida. Unless the certificate is redeemed according to law, the property described in the certificate will be sold to the highest bidder at the Sarasota County Court House, 2000 Main Street, Historic Courtroom, East Wing, Sarasota, Florida, at 9:00 a.m. on the 24TH day of JUNE, 2014.

Karen E. Rushing
Clerk Of The Circuit Court
Sarasota County, Florida
By: T. Lake, Deputy Clerk
Publication Dates: MAY 23, 30; JUNE 6, 13, 2014

14-02274S

FIRST INSERTION

NOTICE OF APPLICATION FOR TAX DEED

Notice is hereby given that PALM TREE TAX 2, LLC PALM TREE TAX LLC CAPITAL ONE, the holder of the certificate listed below, has filed said certificate for a tax deed to be issued. The certificate number and year of issuance, the description of the property, and the names in which the property is assessed are as follows:

Certificate Number: 1767.000
Year of Issuance: 2012
Tax Deed File #: 14-0063 TD

Description of Property: 0124021139 UNIT 23, BLDG 9, VINTAGE GRAND

Name in which the property is assessed: TRISHA SCHULHAUSER & KELLY SCHULHAUSER

All of said property being in the County of Sarasota, State of Florida. Unless the certificate is redeemed according to law, the property described in the certificate will be sold to the highest bidder at the Sarasota County Court House, 2000 Main Street, Historic Courtroom, East Wing, Sarasota, Florida, at 9:00 a.m. on the 24TH day of JUNE, 2014.

Karen E. Rushing
Clerk Of The Circuit Court
Sarasota County, Florida
By: T. Lake, Deputy Clerk
Publication Dates: MAY 23, 30; JUNE 6, 13, 2014

14-02280S

FIRST INSERTION

NOTICE OF APPLICATION FOR TAX DEED

Notice is hereby given that CITRUS CAPITAL LLC - SERIES 44 US BANK % CITRUS CAPITAL LLC, the holder of the certificate listed below, has filed said certificate for a tax deed to be issued. The certificate number and year of issuance, the description of the property, and the names in which the property is assessed are as follows:

Certificate Number: 11149.000
Year of Issuance: 2012
Tax Deed File #: 14-0051 TD

Description of Property: 2004150027 LOT 9 LESS N 3 FT & N 1/2 LOT 11 BLK A DE SOTO TERRACE

Name in which the property is assessed: MICHAEL D BURKART

All of said property being in the County of Sarasota, State of Florida. Unless the certificate is redeemed according to law, the property described in the certificate will be sold to the highest bidder at the Sarasota County Court House, 2000 Main Street, Historic Courtroom, East Wing, Sarasota, Florida, at 9:00 a.m. on the 24TH day of JUNE, 2014.

Karen E. Rushing
Clerk Of The Circuit Court
Sarasota County, Florida
By: T. Lake, Deputy Clerk
Publication Dates: MAY 23, 30; JUNE 6, 13, 2014

14-02269S

FIRST INSERTION

NOTICE OF APPLICATION FOR TAX DEED

Notice is hereby given that BORIS KIEVSKY, the holder of the certificate listed below, has filed said certificate for a tax deed to be issued. The certificate number and year of issuance, the description of the property, and the names in which the property is assessed are as follows:

Certificate Number: 7491.000
Year of Issuance: 2011
Tax Deed File #: 14-0057 TD

Description of Property: 0973171312 LOT 12 BLK 1713 36TH ADD TO PORT CHARLOTTE

Name in which the property is assessed: THOMAS W PERRY JR

All of said property being in the County of Sarasota, State of Florida. Unless the certificate is redeemed according to law, the property described in the certificate will be sold to the highest bidder at the Sarasota County Court House, 2000 Main Street, Historic Courtroom, East Wing, Sarasota, Florida, at 9:00 a.m. on the 24TH day of JUNE, 2014.

Karen E. Rushing
Clerk Of The Circuit Court
Sarasota County, Florida
By: T. Lake, Deputy Clerk
Publication Dates: MAY 23, 30; JUNE 6, 13, 2014

14-02275S

FIRST INSERTION

NOTICE OF APPLICATION FOR TAX DEED

Notice is hereby given that PALM TREE TAX 2, LLC PALM TREE TAX LLC CAPITAL ONE, the holder of the certificate listed below, has filed said certificate for a tax deed to be issued. The certificate number and year of issuance, the description of the property, and the names in which the property is assessed are as follows:

Certificate Number: 3315.000
Year of Issuance: 2012
Tax Deed File #: 14-0065 TD

Description of Property: 0461092009 UNIT S3-1 CIRCLE WOODS OF VENICE SEC 2

Name in which the property is assessed: JUANN A AUSTIN

All of said property being in the County of Sarasota, State of Florida. Unless the certificate is redeemed according to law, the property described in the certificate will be sold to the highest bidder at the Sarasota County Court House, 2000 Main Street, Historic Courtroom, East Wing, Sarasota, Florida, at 9:00 a.m. on the 24TH day of JUNE, 2014.

Karen E. Rushing
Clerk Of The Circuit Court
Sarasota County, Florida
By: T. Lake, Deputy Clerk
Publication Dates: MAY 23, 30; JUNE 6, 13, 2014

14-02281S

FIRST INSERTION

NOTICE OF APPLICATION FOR TAX DEED

Notice is hereby given that CITRUS CAPITAL LLC - SERIES 44 US BANK % CITRUS CAPITAL LLC -, the holder of the certificate listed below, has filed said certificate for a tax deed to be issued. The certificate number and year of issuance, the description of the property, and the names in which the property is assessed are as follows:

Certificate Number: 11307.000
Year of Issuance: 2012
Tax Deed File #: 14-0052 TD

Description of Property: 2020090097 LOT 18 BLK D NEWTOWN HEIGHTS

Name in which the property is assessed: SANDRA GRANT

All of said property being in the County of Sarasota, State of Florida. Unless the certificate is redeemed according to law, the property described in the certificate will be sold to the highest bidder at the Sarasota County Court House, 2000 Main Street, Historic Courtroom, East Wing, Sarasota, Florida, at 9:00 a.m. on the 24TH day of JUNE, 2014.

Karen E. Rushing
Clerk Of The Circuit Court
Sarasota County, Florida
By: T. Lake, Deputy Clerk
Publication Dates: MAY 23, 30; JUNE 6, 13, 2014

14-02270S

FIRST INSERTION

NOTICE OF APPLICATION FOR TAX DEED

Notice is hereby given that BORIS KIEVSKY, the holder of the certificate listed below, has filed said certificate for a tax deed to be issued. The certificate number and year of issuance, the description of the property, and the names in which the property is assessed are as follows:

Certificate Number: 7493.000
Year of Issuance: 2011
Tax Deed File #: 14-0058 TD

Description of Property: 0973171317 LOT 17 BLK 1713 36TH ADD TO PORT CHARLOTTE

Name in which the property is assessed: THOMAS W PERRY

All of said property being in the County of Sarasota, State of Florida. Unless the certificate is redeemed according to law, the property described in the certificate will be sold to the highest bidder at the Sarasota County Court House, 2000 Main Street, Historic Courtroom, East Wing, Sarasota, Florida, at 9:00 a.m. on the 24TH day of JUNE, 2014.

Karen E. Rushing
Clerk Of The Circuit Court
Sarasota County, Florida
By: T. Lake, Deputy Clerk
Publication Dates: MAY 23, 30; JUNE 6, 13, 2014

14-02276S

FIRST INSERTION

NOTICE OF APPLICATION FOR TAX DEED

Notice is hereby given that PALM TREE TAX 2, LLC PALM TREE TAX LLC CAPITAL ONE, the holder of the certificate listed below, has filed said certificate for a tax deed to be issued. The certificate number and year of issuance, the description of the property, and the names in which the property is assessed are as follows:

Certificate Number: 4454.000
Year of Issuance: 2012
Tax Deed File #: 14-0066 TD

Description of Property: 0791061118 LOT 118 LA CASA

Name in which the property is assessed: GEORGE F CHARETTE TTEE & GEORGE F CHARETTE EST & JOHN M CHARETTE PR

All of said property being in the County of Sarasota, State of Florida. Unless the certificate is redeemed according to law, the property described in the certificate will be sold to the highest bidder at the Sarasota County Court House, 2000 Main Street, Historic Courtroom, East Wing, Sarasota, Florida, at 9:00 a.m. on the 24TH day of JUNE, 2014.

Karen E. Rushing
Clerk Of The Circuit Court
Sarasota County, Florida
By: T. Lake, Deputy Clerk
Publication Dates: MAY 23, 30; JUNE 6, 13, 2014

14-02282S

FIRST INSERTION

NOTICE OF APPLICATION FOR TAX DEED

Notice is hereby given that CITRUS CAPITAL LLC - SERIES 44 US BANK % CITRUS CAPITAL LLC -, the holder of the certificate listed below, has filed said certificate for a tax deed to be issued. The certificate number and year of issuance, the description of the property, and the names in which the property is assessed are as follows:

Certificate Number: 11740.000
Year of Issuance: 2012
Tax Deed File #: 14-0053 TD

Description of Property: 2027102003 UNIT 3, VILLAS ON LAUREL THE

Name in which the property is assessed: LHR VENTURES LLC

All of said property being in the County of Sarasota, State of Florida. Unless the certificate is redeemed according to law, the property described in the certificate will be sold to the highest bidder at the Sarasota County Court House, 2000 Main Street, Historic Courtroom, East Wing, Sarasota, Florida, at 9:00 a.m. on the 24TH day of JUNE, 2014.

Karen E. Rushing
Clerk Of The Circuit Court
Sarasota County, Florida
By: T. Lake, Deputy Clerk
Publication Dates: MAY 23, 30; JUNE 6, 13, 2014

14-02271S

FIRST INSERTION

NOTICE OF APPLICATION FOR TAX DEED

Notice is hereby given that BORIS KIEVSKY, the holder of the certificate listed below, has filed said certificate for a tax deed to be issued. The certificate number and year of issuance, the description of the property, and the names in which the property is assessed are as follows:

Certificate Number: 11236.000
Year of Issuance: 2011
Tax Deed File #: 14-0059 TD

Description of Property: 1142259624 LOT 24 BLK 2596 51ST ADD TO PORT CHARLOTTE

Name in which the property is assessed: SARASOTA INVESTMENT TRUST

All of said property being in the County of Sarasota, State of Florida. Unless the certificate is redeemed according to law, the property described in the certificate will be sold to the highest bidder at the Sarasota County Court House, 2000 Main Street, Historic Courtroom, East Wing, Sarasota, Florida, at 9:00 a.m. on the 24TH day of JUNE, 2014.

Karen E. Rushing
Clerk Of The Circuit Court
Sarasota County, Florida
By: T. Lake, Deputy Clerk
Publication Dates: MAY 23, 30; JUNE 6, 13, 2014

14-02277S

FIRST INSERTION

NOTICE OF APPLICATION FOR TAX DEED

Notice is hereby given that PALM TREE TAX 2, LLC PALM TREE TAX LLC CAPITAL ONE, the holder of the certificate listed below, has filed said certificate for a tax deed to be issued. The certificate number and year of issuance, the description of the property, and the names in which the property is assessed are as follows:

Certificate Number: 4455.000
Year of Issuance: 2012
Tax Deed File #: 14-0067 TD

Description of Property: 0791061130 LOT 130 LA CASA

Name in which the property is assessed: GEORGE H HILL III & VIRDAY H MC CULLEY

All of said property being in the County of Sarasota, State of Florida. Unless the certificate is redeemed according to law, the property described in the certificate will be sold to the highest bidder at the Sarasota County Court House, 2000 Main Street, Historic Courtroom, East Wing, Sarasota, Florida, at 9:00 a.m. on the 24TH day of JUNE, 2014.

Karen E. Rushing
Clerk Of The Circuit Court
Sarasota County, Florida
By: T. Lake, Deputy Clerk
Publication Dates: MAY 23, 30; JUNE 6, 13, 2014

14-02283S

FIRST INSERTION

NOTICE OF APPLICATION FOR TAX DEED

Notice is hereby given that ERIKA GINSBERG KLEMMT, the holder of the certificate listed below, has filed said certificate for a tax deed to be issued. The certificate number and year of issuance, the description of the property, and the names in which the property is assessed are as follows:

Certificate Number: 1156.000
Year of Issuance: 2012
Tax Deed File #: 14-0054 TD

Description of Property: 0079090002 LOTS 22 THRU 32, BLK 4, SIESTA BEACH, LESS THAT PORTION COMPRISING SUBMERGED LANDS IN ROBERTS BAY

Name in which the property is assessed: CL SIESTA INC

All of said property being in the County of Sarasota, State of Florida. Unless the certificate is redeemed according to law, the property described in the certificate will be sold to the highest bidder at the Sarasota County Court House, 2000 Main Street, Historic Courtroom, East Wing, Sarasota, Florida, at 9:00 a.m. on the 24TH day of JUNE, 2014.

Karen E. Rushing
Clerk Of The Circuit Court
Sarasota County, Florida
By: T. Lake, Deputy Clerk
Publication Dates: MAY 23, 30; JUNE 6, 13, 2014

14-02272S

FIRST INSERTION

NOTICE OF APPLICATION FOR TAX DEED

Notice is hereby given that BORIS KIEVSKY, the holder of the certificate listed below, has filed said certificate for a tax deed to be issued. The certificate number and year of issuance, the description of the property, and the names in which the property is assessed are as follows:

Certificate Number: 11237.000
Year of Issuance: 2011
Tax Deed File #: 14-0060 TD

Description of Property: 1142259625 LOT 25 BLK 2596 51ST ADD TO PORT CHARLOTTE

Name in which the property is assessed: SARASOTA INVESTMENT TRUST

All of said property being in the County of Sarasota, State of Florida. Unless the certificate is redeemed according to law, the property described in the certificate will be sold to the highest bidder at the Sarasota County Court House, 2000 Main Street, Historic Courtroom, East Wing, Sarasota, Florida, at 9:00 a.m. on the 24TH day of JUNE, 2014.

Karen E. Rushing
Clerk Of The Circuit Court
Sarasota County, Florida
By: T. Lake, Deputy Clerk
Publication Dates: MAY 23, 30; JUNE 6, 13, 2014

14-02278S

FIRST INSERTION

NOTICE OF APPLICATION FOR TAX DEED

Notice is hereby given that PALM TREE TAX 2, LLC PALM TREE TAX LLC CAPITAL ONE, the holder of the certificate listed below, has filed said certificate for a tax deed to be issued. The certificate number and year of issuance, the description of the property, and the names in which the property is assessed are as follows:

Certificate Number: 4462.000
Year of Issuance: 2012
Tax Deed File #: 14-0068 TD

Description of Property: 0791061587 LOT 587 LA CASA

Name in which the property is assessed: CAROL L KORTJOHN & OLIVER H KORTJOHN

All of said property being in the County of Sarasota, State of Florida. Unless the certificate is redeemed according to law, the property described in the certificate will be sold to the highest bidder at the Sarasota County Court House, 2000 Main Street, Historic Courtroom, East Wing, Sarasota, Florida, at 9:00 a.m. on the 24TH day of JUNE, 2014.

Karen E. Rushing
Clerk Of The Circuit Court
Sarasota County, Florida
By: T. Lake, Deputy Clerk
Publication Dates: MAY 23, 30; JUNE 6, 13, 2014

14-02284S

FIRST INSERTION

NOTICE OF APPLICATION FOR TAX DEED

Notice is hereby given that ERIKA GINSBERG KLEMMT, the holder of the certificate listed below, has filed said certificate for a tax deed to be issued. The certificate number and year of issuance, the description of the property, and the names in which the property is assessed are as follows:

Certificate Number: 11111.000
Year of Issuance: 2012
Tax Deed File #: 14-0055 TD

Description of Property: 2002010002 BEG AT SW COR OF LOT 10 BLK 5 TH S ALG EXT IN A SLY DIR OF W LINE OF LOT 10 TO S SIDE OF EDWARDS DR FOR POB TH CONT S IN SAME DIR 39.5 FT M/L TO THE WATERS OF LAKE UPLAND TH CONT

IN SAME DIR 67.5 FT M/L TH ELY 118.5 FT M/L TH NLY 126.5 FT M/L TO S SIDE OF EDWARDS DR TH WLY ALG S LINE OF EDWARDS DR TO POB THE UPLANDS

Name in which the property is assessed: FRANCES E BAILEY

All of said property being in the County of Sarasota, State of Florida. Unless the certificate is redeemed according to law, the property described in the certificate will be sold to the highest bidder at the Sarasota County Court House, 2000 Main Street, Historic Courtroom, East Wing, Sarasota, Florida, at 9:00 a.m. on the 24TH day of JUNE, 2014.

Karen E. Rushing
Clerk Of The Circuit Court
Sarasota County, Florida
By: T. Lake, Deputy Clerk
Publication Dates: MAY 23, 30; JUNE 6, 13, 2014

14-02273S

FIRST INSERTION

NOTICE OF SALE AND ACTION FOR PUBLICATION

IN THE CIRCUIT COURT OF THE TWELFTH JUDICIAL CIRCUIT IN AND FOR SARASOTA COUNTY, FLORIDA

CIVIL DIVISION
Case No. 2012 CA 001763 NC

JAMES RINI & DAVE DAVIS, Plaintiff, v.

LARRY FRANK MATTACCHIONE, SR. & SHIRLEY MATTACCHIONE Defendants.

YOU ARE NOTIFIED that pursuant to a Order Granting Plaintiff's Motion to Set Sale entered in the above styled cause, in the Circuit Court of SARASOTA County, Florida, I will sell the property situate in SARASOTA County, Florida described as:

Lots 16-17 Blk H Palm Grove PB 1/69, according to the map or plat thereof as recorded in Plat Book, Public Records of Sarasota County, Florida

at public sale, to the highest bidder or bidders for cash on www.sarasota.realforeclose.com on June 20, 2014 at 9:00 a.m.

If you are a person with a disability who needs any accommodation in order to participate in this proceeding, you are entitled, at no cost to you, to the provision of certain assistance. Please contact the Sarasota County Jury Office, P.O. Box 3079, Sarasota, Florida 34230-3079, (941)861-7400, at least seven (7) days before your scheduled court appearance, or immediately upon receiving this notification if the time before the scheduled appearance is less than seven (7) days; if you are hearing or voice impaired, call 711. Galewski Law Group, P.A.

1112 E. Kennedy Blvd.
Tampa, FL 33602
Telephone 813.222.8210
Facsimile 813.222.8211
Website www.galewski.com
May 23, 30, 2014 14-02322S

FIRST INSERTION

Decedent's name: Chester S. Mazur
The file number of the estate: 2014-CP-000832

The designation and address of the court in which the proceedings are pending: Circuit Court, Sarasota County, Probate Division.

The personal representative's name and address: Chester M. Mazur, 7283 East Quaker Street, Orchard Park, NY 14127. The name and address of the personal representative's attorney: Edward A. Pace, Esq., 4513 S. Buffalo, Street, Orchard Park, NY 14127

May 23, 30, 2014 14-02328S

FIRST INERTION

RE-NOTICE OF FORECLOSURE SALE IN THE CIRCUIT COURT OF THE 12TH JUDICIAL CIRCUIT, IN AND FOR SARASOTA COUNTY, FLORIDA

CIVIL DIVISION:
CASE NO.: 2012 CA 010412 NC

ACHIEVA CREDIT UNION FORMERLY KNOWN AS SARASOTA COASTAL CREDIT UNION,

Plaintiff, vs.

MARY K. MOBLEY; ACHIEVA CREDIT UNION FORMERLY

KNOWN AS SARASOTA COASTAL CREDIT UNION; GROVE POINTE HOMEOWNERS ASSOCIATION, INC.; REICHARD S. MOBLEY, SR.; UNKNOWN TENANT IN POSSESSION OF THE SUBJECT PROPERTY,

Defendants.

NOTICE IS HEREBY GIVEN pursuant to an Order Resetting Foreclosure Sale dated the 7th day of May, 2014, and entered in Case No. 2012 CA 010412 NC, of the Circuit Court of the 12TH Judicial Circuit in and for Sarasota County, Florida, wherein ACHIEVA CREDIT

UNION FORMERLY KNOWN AS SARASOTA COASTAL CREDIT UNION is the Plaintiff and MARY K. MOBLEY; ACHIEVA CREDIT UNION FORMERLY KNOWN AS SARASOTA COASTAL CREDIT UNION; GROVE POINTE HOMEOWNERS ASSOCIATION, INC.; REICHARD S. MOBLEY, SR.

FIRST INSERTION	FIRST INSERTION	FIRST INSERTION	FIRST INSERTION
<p>NOTICE OF FORECLOSURE SALE IN THE CIRCUIT COURT OF THE AND FOR SARASOTA COUNTY, FLORIDA</p> <p>CASE NO.: 2010 CA 007176 NC</p> <p>JPMORGAN CHASE BANK, NATIONAL ASSOCIATION Plaintiff, vs. THOMAS W. HEFNER; ANGELA HEFNER; JPMORGAN CHASE BANK, NATIONAL ASSOCIATION, SUCCESSOR IN INTEREST TO WASHINGTON MUTUAL BANK F/K/A WASHINGTON MUTUAL BANK, FA; UNKNOWN TENANT #1; UNKNOWN TENANT #2 Defendants.</p> <p>NOTICE is hereby given that the Clerk of the Circuit Court of Sarasota County, Florida, will on the 13th day of June 2014, at 9:00 a.m. at www.sarasota.realforeclose.com in accordance with Chapter 45 Florida Statutes, offer for sale and sell at public outcry to the highest and best bidder for cash, the following-described property situate in Sarasota County, Florida:</p> <p>LOT(S) 2958 AND 2959, UNIT 10, SOUTH VENICE, ACCORDING TO THE PLAT THEREOF, AS RECORDED IN PLAT BOOK 6, PAGE 46, OF THE PUBLIC RECORDS OF SARASOTA COUNTY, FLORIDA</p> <p>pursuant to the Final Judgment entered in a case pending in said Court, the style of which is indicated above.</p> <p>Any person or entity claiming an interest in the surplus, if any, resulting from the foreclosure sale, other than the property owner as of the date of the Lis Pendens, must file a claim on same with the Clerk of Court within 60 days after the foreclosure sale.</p> <p>If you are a person with a disability who needs any accommodation in order to participate in this proceeding, you are entitled, at no cost to you, to the provision of certain assistance. Please contact the Sarasota County Jury Office, P.O. Box 3079, Sarasota, Florida 34230-3079, (941)861-7400, at least seven (7) days before your scheduled court appearance, or immediately upon receiving this notification if the time before the scheduled appearance is less than seven (7) days; if you are hearing or voice impaired, call 711</p> <p>DATED this 16th day of May, 2014.</p> <p>John J. Bennett Florida Bar Number: 98257 Antonio Andres Caula, Esquire BUTLER & HOSCH, P.A. 3185 South Conway Road, Suite E Orlando, Florida 32812 Telephone: (407) 381-5200 Fax: (407) 381-5577 Florida Bar No: 103300 ac106892@butlerandhosch.com FLPleadings@butlerandhosch.com B&H # 295999 May 23, 30, 2014 14-02296S</p>	<p>NOTICE OF SALE IN THE CIRCUIT COURT OF THE TWELFTH JUDICIAL CIRCUIT IN AND FOR SARASOTA COUNTY, FLORIDA</p> <p>CIVIL DIVISION</p> <p>Case #: 2009-CA-001387-NC</p> <p>DIVISION: A</p> <p>Everhome Mortgage Company Plaintiff, vs.- Bridget Ryan; Unknown Spouse of Bridget Ryan, if married; Suntrust Bank; John Doe and Jane Doe Defendant(s).</p> <p>NOTICE IS HEREBY GIVEN pursuant to order rescheduling foreclosure sale or Final Judgment, entered in Civil Case No. 2009-CA-001387-NC of the Circuit Court of the 12th Judicial Circuit in and for Sarasota County, Florida, wherein Everhome Mortgage Company, Plaintiff and Bridget Ryan are defendant(s), I, Clerk of Court, Karen E. Rushing, will sell to the highest and best bidder for cash VIA THE INTERNET AT WWW.SARASOTA.REALFORECLOSE.COM, AT 9:00 A.M. on June 16, 2014, the following described property as set forth in said Final Judgment, to-wit:</p> <p>LOTS 12576 & 12577, SOUTH VENICE, UNIT NO. 48, ACCORDING TO THE PLAT THEREOF, RECORDED IN PLAT BOOK 7, PAGE 12, OF THE PUBLIC RECORDS OF SARASOTA COUNTY, FLORIDA.</p> <p>ANY PERSON CLAIMING AN INTEREST IN THE SURPLUS FROM THE SALE, IF ANY, OTHER THAN THE PROPERTY OWNER AS OF THE DATE OF THE LIS PENDENS MUST FILE A CLAIM WITHIN 60 DAYS AFTER THE SALE.</p> <p>If you are a person with a disability who needs any accommodation in order to participate in this proceeding, you are entitled, at no cost to you, to the provision of certain assistance. Please contact the Sarasota County Jury Office, P.O. Box 3079, Sarasota, Florida 34230-3079, (941)861-7400, at least seven (7) days before your scheduled court appearance, or immediately upon receiving this notification if the time before the scheduled appearance is less than seven (7) days; if you are hearing or voice impaired, call 711.</p> <p>Submitted By: ATTORNEY FOR PLAINTIFF: SHAPIRO, FISHMAN & GACHE, LLP 2424 North Federal Highway, Suite 360 Boca Raton, Florida 33431 (561) 998-6700 (561) 998-6707 11-228843 FCO1 CXE May 23, 30, 2014 14-02234S</p>	<p>NOTICE OF FORECLOSURE SALE IN THE CIRCUIT COURT OF THE TWELFTH JUDICIAL CIRCUIT IN AND FOR SARASOTA COUNTY, FLORIDA</p> <p>Case No: 2013 CA 003101 NC</p> <p>JPMORGAN CHASE BANK NATIONAL ASSOCIATION, Plaintiff, vs. CHERYL AMENTASTRO, ET AL, Defendants.</p> <p>NOTICE IS HEREBY GIVEN that pursuant to the Final Judgment of Foreclosure dated May 12, 2014 and entered in Case No. 2013-CA-003101-NC of the Circuit Court of the Twelfth Judicial Circuit in and for Sarasota County, Florida wherein, CHRISTIANA TRUST, A DIVISION OF WILMINGTON SAVINGS FUND SOCIETY, FSB, AS TRUSTEE FOR NORMANDY MORTGAGE LOAN TRUST, SERIES 2013-18, is the Plaintiff and CHERYL AMENTASTRO, ET AL are the Defendant(s), I will sell to the highest and best bidder for cash at www.sarasota.realforeclose.com at 9:00 a.m. or as soon as possible on June 18, 2014, the following described property set forth in said Final Judgment, to wit:</p> <p>LOT 4, BLOCK 2503, 50th ADDITION TO PORT CHARLOTTE SUBDIVISION, ACCORDING TO THE PLAT THEREOF, AS RECORDED IN PLAT BOOK 21, PAGE 7, OF THE PUBLIC RECORDS OF SARASOTA COUNTY, FLORIDA.</p> <p>Any person or entity claiming an interest in the surplus, if any, resulting from the Foreclosure Sale, other than the property owner as of the date of the Lis Pendens, must file a claim on same with the Clerk of Court within sixty (60) days after the Foreclosure Sale.</p> <p>If you are a person with a disability who needs any accommodation in order to participate in this proceeding, you are entitled, at no cost to you, to the provision of certain assistance. Please contact the Sarasota County Jury Office, P.O. Box 3079, Sarasota, Florida 34230-3079, (941)861-7400, at least seven (7) days before your scheduled court appearance, or immediately upon receiving this notification if the time before the scheduled appearance is less than seven (7) days; if you are hearing or voice impaired, call 711.</p> <p>DATED May 19, 2014</p> <p>/s/ Nancy Alvarez Nancy Alvarez, Esq. Florida Bar No. 068122</p> <p>Lender Legal Services, LLC 201 East Pine Street, Suite 730 Orlando, Florida 32801 Tel: (407) 730-4644 Fax: (888) 337-3815 Attorney for Plaintiff nalvarez@lenderlegal.com EService@LenderLegal.com May 23, 30, 2014 14-02301S</p>	<p>NOTICE OF SALE IN THE CIRCUIT CIVIL COURT OF THE TWELFTH JUDICIAL CIRCUIT OF FLORIDA, IN AND FOR SARASOTA COUNTY</p> <p>CIVIL DIVISION</p> <p>Case No. 58-2012-CA-003300 NC Division C</p> <p>BAYVIEW LOAN SERVICING, LLC Plaintiff, vs. KENNETH J. NELSON A/K/A KENNETH NELSON, VIRGINIA J. NELSON A/K/A VIRGINIA NELSON, CITICORP TRUST BANK, FSB, AND UNKNOWN TENANTS/OWNERS, Defendants.</p> <p>Notice is hereby given, pursuant to Final Judgment of Foreclosure for Plaintiff entered in this cause on May 8, 2014, in the Circuit Court of Sarasota County, Florida, The Clerk of the Court will sell the property situated in Sarasota County, Florida described as:</p> <p>LOT 18, BLOCK 106, OF 7TH ADDITION TO PORT CHARLOTTE SUBDIVISION, ACCORDING TO THE PLAT THEREOF, AS RECORDED IN PLAT BOOK 12, PAGES 19, 19A THROUGH 19N, IN THE PUBLIC RECORDS OF SARASOTA COUNTY, FLORIDA.</p> <p>and commonly known as: 3834 SOUTH CHAMBERLAIN BLVD, NORTH PORT, FL 34286; including the building, appurtenances, and fixtures located therein, at public sale, to the highest and best bidder, for cash, Sales are held online at: https://www.sarasota.realforeclose.com, on June 12, 2014 at 9:00 A.M..</p> <p>Any persons claiming an interest in the surplus from the sale, if any, other than the property owner as of the date of the lis pendens must file a claim within 60 days after the sale.</p> <p>If you are a person with a disability who needs any accommodation in order to participate in this proceeding, you are entitled, at no cost to you, to the provision of certain assistance. Please contact the Sarasota County Jury Office, P.O. Box 3079, Sarasota, Florida 34230-3079, (941)861-7400, at least seven (7) days before your scheduled court appearance, or immediately upon receiving this notification if the time before the scheduled appearance is less than seven (7) days; if you are hearing or voice impaired, call 711.</p> <p>Karen E. Rushing By: Frances Grace Cooper, Esquire Attorney for Plaintiff</p> <p>Edward B. Pritchard (813) 229-0900 x1309 Kass Shuler, P.A. P.O. Box 800 Tampa, FL 33601-0800 ForeclosureService@kasslaw.com 200850/1444377/ May 23, 30, 2014 14-02300S</p>

FIRST INERTION	FIRST INERTION	FIRST INERTION	FIRST INERTION
<p>NOTICE OF FORECLOSURE SALE IN THE CIRCUIT COURT OF THE TWELFTH JUDICIAL CIRCUIT, IN AND FOR SARASOTA COUNTY, FLORIDA</p> <p>CASE NO. 2010 CA 010213 NC</p> <p>BANK OF AMERICA, N.A., Plaintiff, vs. GLEN J. WHITNEY, et al. Defendants</p> <p>NOTICE IS HEREBY GIVEN pursuant to a Final Judgment of Foreclosure dated April 23, 2014, and entered in Case No. 2010 CA 010213 NC, of the Circuit Court of the Twelfth Judicial Circuit in and for SARASOTA COUNTY, Florida. NATIONSTAR MORTGAGE LLC, is Plaintiff and GLEN J. WHITNEY; UNKNOWN SPOUSE OF GLEN J. WHITNEY; EILEEN E. WHITNEY A/K/A EE WHITNEY; UNKNOWN SPOUSE OF EILEEN E. WHITNEY A/K/A EE WHITNEY, are defendants. The Clerk of Court will sell to the highest and best bidder for cash via the Internet at www.sarasota.realforeclose.com, at 9:00 a.m., on the 23rd day of June, 2014, the following described property as set forth in said Final Judgment, to wit:</p> <p>LOTS 6 AND 8, BLOCK 4, GOLF ESTATES, AS PER PLAT THEREOF RECORDED IN PLAT BOOK 2, PAGE 131, OF THE PUBLIC RECORDS OF SARASOTA COUNTY, FLORIDA. LESS THE WESTERN-MOST TWO FEET (2') OF LOTS 6 AND 8, BLOCK 4 OF GOLF ESTATES (WHICH DIRECTLY BORDER LOTS 5 AND 7, BLOCK 4 OF GOLF ESTATES), A SUBDIVISION IN SECTION 4, TOWNSHIP 37 SOUTH, RANGE 18 EAST AS RECORDED IN PLAT BOOK NO.2, PAGE 131, OF THE PUBLIC RECORDS</p> <p>OF SARASOTA COUNTY, FLORIDA. TOGETHER WITH A PERPETUAL NON-EXCLUSIVE EASEMENT FOR INGRESS, EGRESS, ROAD PURPOSES, DRAINAGE AND UTILITY USE, OVER, UNDER, UPON AND ACROSS THE SOUTH 10 FEET OF LOT 3, BLOCK 4 AND THE NORTH 10 FEET OF LOT 5, BLOCK 4, GOLF ESTATES, AS RECORDED IN OFFICIAL RECORDS BOOK 1252, PAGE 1463 AND OFFICIAL RECORDS BOOK 1252, PAGE 1465, RESPECTIVELY, OF SAID RECORDS.</p> <p>Any person claiming an interest in the surplus from the sale, if any, other than the property owner as of the date of the Lis Pendens must file a claim within 60 days after the sale.</p> <p>If you are a person with a disability who needs any accommodation in order to participate in this proceeding, you are entitled, at no cost to you, to the provision of certain assistance. Please contact the Sarasota County Jury Office, P.O. Box 3079, Sarasota, Florida 34230-3079, (941)861-7400, at least seven (7) days before your scheduled court appearance, or immediately upon receiving this notification if the time before the scheduled appearance is less than seven (7) days; if you are hearing or voice impaired, call 711.</p> <p>Mark C. Elia, Esq. Florida Bar #: 695734 Email: MCElia@vanlawfl.com</p> <p>VAN NESS LAW FIRM, PLC 1239 E. Newport Center Drive, Suite 110 Deerfield Beach, Florida 33442 Ph: (954) 571-2031 Fax: (954) 571-2033 PRIMARY EMAIL: Pleadings@vanlawfl.com May 23, 30, 2014 14-02305S</p>	<p>NOTICE OF FORECLOSURE SALE IN THE CIRCUIT COURT OF THE TWELFTH JUDICIAL CIRCUIT IN AND FOR SARASOTA COUNTY, FLORIDA</p> <p>CIVIL DIVISION</p> <p>CASE NO. 2013 CA 001206 NC C</p> <p>BRANCH BANKING AND TRUST COMPANY, Plaintiff, v. FRANK DAMELIO A/K/A FRANK A. DAMELIO; UNKNOWN SPOUSE OF FRANK DAMELIO A/K/A FRANK A. DAMELIO; MYRIAM DAMELIO; UNKNOWN SPOUSE OF MYRIAM DAMELIO; PHILLIPPI HARBOR CLUB CONDOMINIUM ASSOCIATION, INC., ANY AND ALL UNKNOWN PARTIES CLAIMING BY, THROUGH, UNDER, AND AGAINST THE HEREIN NAMED INDIVIDUAL DEFENDANTS WHO ARE NOT KNOWN TO BE DEAD OR ALIVE, WHETHER SAID UNKNOWN PARTIES MAY CLAIM AN INTEREST AS SPOUSES, HEIRS, DEVISEES, GRANTEES, OR OTHER CLAIMANTS; TENANT #1; TENANT #2, Defendants.</p> <p>Notice is hereby given, pursuant to Final Judgment of Foreclosure for Plaintiff entered in this cause, in the Circuit Court of SARASOTA County, Florida, the Clerk of the Court will sell the property situated in SARASOTA County, Florida described as:</p> <p>UNIT D2-38, PHILLIPPI HARBOR CLUB, A CONDOMINIUM, ACCORDING TO THE DECLARATION OF CONDOMINIUM AND CONDOMINIUM PLAT THEREOF RECORDED IN OFFICIAL RECORDS INSTRUMENT #2007026547, AND</p>	<p>AMENDMENTS THERETO, AND AS PER PLAT THEREOF, RECORDED IN CONDOMINIUM PLAT BOOK 40, PAGES 27-27G AND AMENDMENTS THERETO, OF THE PUBLIC RECORDS OF SARASOTA COUNTY, FLORIDA.</p> <p>and commonly known as: 1780 Phillippi Harbor Drive #D2-38, Sarasota, FL 34231, at public sale, to the highest and best bidder, for cash, at www.sarasota.realforeclose.com, on JUNE 17, 2014 at 9:00 A.M.</p> <p>ANY PERSON CLAIMING AN INTEREST IN THE SURPLUS FROM THE SALE, IF ANY, OTHER THAN THE PROPERTY OWNER AS OF THE DATE OF THE LIS PENDENS MUST FILE A CLAIM WITHIN 60 DAYS AFTER THE SALE.</p> <p>If you are a person with a disability who needs any accommodation in order to participate in this proceeding, you are entitled, at no cost to you, to the provision of certain assistance. Please contact the Sarasota County Jury Office, P.O. Box 3079, Sarasota, Florida 34230-3079, (941)861-7400, at least seven (7) days before your scheduled court appearance, or immediately upon receiving this notification if the time before the scheduled appearance is less than seven (7) days; if you are hearing or voice impaired, call 711.</p> <p>Dated this 5.19.14</p> <p>Ross S. Felsher, Esq., FL Bar # 78169</p> <p>ROBERT M. COPLEN, P.A. 10225 Ulmertown Road, Suite 5A Largo, FL 33771 Telephone (727) 588-4550 Fax (727) 559-0887 Designated E-mail: Foreclosure@coplenlaw.net Attorney for Plaintiff May 23, 30, 2014 14-02294S</p>	<p>NOTICE OF FORECLOSURE SALE IN THE CIRCUIT COURT OF THE TWELFTH JUDICIAL CIRCUIT IN AND FOR SARASOTA COUNTY, FLORIDA</p> <p>CIVIL DIVISION</p> <p>CASE NO. 2013CA005313NC</p> <p>BANKUNITED, N.A. Plaintiff, vs. ALAN REISINGER A/K/A ALAN J. REISINGER; DONNA REISINGER A/K/A DONNA J. REISINGER; et al; Defendants.</p> <p>NOTICE IS HEREBY GIVEN pursuant to a Final Judgment of Foreclosure dated February 26, 2014, and entered in Case No. 2013CA005313NC, of the Circuit Court of the 12th Judicial Circuit in and for SARASOTA County, Florida, wherein BANKUNITED, N.A. is Plaintiff and ALAN REISINGER A/K/A ALAN J. REISINGER; DONNA REISINGER A/K/A DONNA J. REISINGER; UNKNOWN PERSON(S) IN POSSESSION OF THE SUBJECT PROPERTY; PIER 550 CONDOMINIUM ASSOCIATION, INC.; are defendants. The Clerk of Court will sell to the highest and best bidder for cash BY ELECTRONIC SALE AT: WWW.SARASOTA.REALFORECLOSE.COM, at 9:00 A.M., on the 26 day of June, 2014, the following described property as set forth in said Final Judgment, to wit:</p> <p>UNIT 5, MONACO BUILDING, PIER 550, A CONDOMINIUM ACCORDING TO THE DECLARATION OF CONDOMINIUM THEREOF,</p> <p>AS RECORDED IN OFFICIAL RECORDS BOOK 1245, PAGE 1521, AND AS PER PLAT THEREOF RECORDED IN CONDOMINIUM BOOK 11, PAGES 6, 6A AND 6B OF THE PUBLIC RECORDS OF SARASOTA COUNTY, FLORIDA.</p> <p>A person claiming an interest in the surplus from the sale, if any, other than the property owner as of the date of the lis pendens must file a claim within 60 days after the sale.</p> <p>If you are a person with a disability who needs any accommodation in order to participate in this proceeding, you are entitled, at no cost to you, to the provision of certain assistance. Please contact the Sarasota County Jury Office, P.O. Box 3079, Sarasota, Florida 34230-3079, (941)861-7400, at least seven (7) days before your scheduled court appearance, or immediately upon receiving this notification if the time before the scheduled appearance is less than seven (7) days; if you are hearing or voice impaired, call 711.</p> <p>Dated this 20 day of May, 2014.</p> <p>Eric M. Knopp, Esq. Bar No.: 709921</p> <p>Submitted by: Kahane & Associates, P.A. 8201 Peters Road, Ste.3000 Plantation, FL 33324 Telephone: (954) 382-3486 Telefacsimile: (954) 382-5380 Designated service email: notice@kahaneandassociates.com File No.: 13-03346 BU V1.20140101 May 23, 30, 2014 14-02323S</p>

PUBLISH YOUR LEGAL NOTICES IN THE BUSINESS OBSERVER

(813) 221-9505 Hillsborough, Pasco
(727) 447-7784 Pinellas
(941) 906-9386 Manatee, Sarasota, Lee
(239) 263-0122 Collier
(941) 249-4900 Charlotte
(407) 654-5500 Orange

FIRST INSERTION	FIRST INSERTION
<p>NOTICE OF PUBLIC SALE</p> <p>Notice is hereby given that on 6/6/14 at 10:30 am the following mobile homes will be sold at public auction pursuant to FS: 715.109: 1987 SHUL #1YP200R26GA001181. Last Tenant: Diane Elizabeth Hripak. Sale to be held at Realty Systems- Arizona Inc- 1300 N River Rd, Venice, FL 34293 813-241-8269 May 23, 30, 2014 14-02289S</p>	<p>NOTICE OF APPLICATION FOR TAX DEED</p> <p>Notice is hereby given that PALM TREE TAX 2, LLC PALM TREE TAX LLC CAPITAL ONE, the holder of the certificate listed below, has filed said certificate for a tax deed to be issued. The certificate number and year of issuance, the description of the property, and the names in which the property is assessed are as follows:</p> <p>Certificate Number: 1395.000</p>

FIRST INSERTION	FIRST INSERTION	FIRST INSERTION	FIRST INSERTION
<p>NOTICE OF FORECLOSURE SALE IN THE CIRCUIT COURT OF THE TWELFTH JUDICIAL CIRCUIT IN AND FOR SARASOTA COUNTY, FLORIDA</p> <p>CIVIL ACTION</p> <p>CASE NO.: 2013 CA 007405 NC Division C</p> <p>WELLS FARGO BANK, NA, Plaintiff, vs. KENNETH D. DOERR A/K/A KENNETH DOERR, et al, Defendant(s).</p> <p>NOTICE IS HEREBY GIVEN pursuant to a Final Judgment of Mortgage Foreclosure dated May 12, 2014 and entered in Case No. 2013 CA 007405 NC of the Circuit Court of the TWELFTH Judicial Circuit in and for SARASOTA County, Florida wherein WELLS FARGO BANK, NA is the Plaintiff and KENNETH D. DOERR A/K/A KENNETH DOERR; ANY AND ALL UNKNOWN PARTIES CLAIMING BY, THROUGH, UNDER, AND AGAINST THE HEREIN NAMED INDIVIDUAL DEFENDANT(S) WHO ARE NOT KNOWN TO BE DEAD OR ALIVE, WHETHER SAID UNKNOWN PARTIES MAY CLAIM AN INTEREST AS SPOUSES, HEIRS, DEVISEES, GRANTEES, OR OTHER CLAIMANTS; OYSTER BAY ESTATES ASSOCIATION, INC.; are the Defendants, The Clerk will sell to the highest and best bidder for cash at WWW.SARASOTA.REALFORECLOSE.COM at 9:00AM, on the 18th day of June, 2014, the following described property as set forth in said Final Judgment:</p> <p>LOT 27, BLOCK F, OYSTER BAY ESTATES, ACCORDING TO THE PLAT THEREOF, RECORDED IN PLAT BOOK 5, PAGES 79, 79A, 79B AND 79C OF THE PUBLIC RECORDS OF SARASOTA COUNTY, FLORIDA.</p> <p>A/K/A 1641 FIELD ROAD, SARASOTA, FL 34231-2307</p> <p>Any person claiming an interest in the surplus from the sale, if any, other than the property owner as of the date of the Lis Pendens must file a claim within sixty (60) days after the sale.</p> <p>If you are a person with a disability who needs any accommodation in order to participate in this proceeding, you are entitled, at no cost to you, to the provision of certain assistance. Please contact the Sarasota County Jury Office, P.O. Box 3079, Sarasota, Florida 34230-3079, (941)861-7400, at least seven (7) days before your scheduled court appearance, or immediately upon receiving this notification if the time before the scheduled appearance is less than seven (7) days; if you are hearing or voice impaired, call 711.</p> <p>By: Matthew Wolf Florida Bar No. 92611</p> <p>Ronald R Wolfe & Associates, P.L. P.O. Box 25018 Tampa, Florida 33622-5018 (813) 251-4766 (813) 251-1541 Fax F13014212 May 23, 30, 2014 14-02263S</p>	<p>Year of Issuance: 2012 Tax Deed File #: 14-0062 TD</p> <p>Description of Property: 0089130015 LOT 31 & E 10 FT LOT 32 BENEVA PARK</p> <p>Name in which the property is assessed: WINIFRED DEGREGORIO & JOSEPH DEGREGORIO JR All of said property being in the County of Sarasota, State of Florida. Unless the certificate is redeemed according to law, the prop-</p>	<p>Year of Issuance: 2012 Tax Deed File #: 14-0062 TD</p> <p>Description of Property: 0089130015 LOT 31 & E 10 FT LOT 32 BENEVA PARK</p> <p>Name in which the property is assessed: WINIFRED DEGREGORIO & JOSEPH DEGREGORIO JR All of said property being in the County of Sarasota, State of Florida. Unless the certificate is redeemed according to law, the prop-</p>	<p>erty described in the certificate will be sold to the highest bidder at the Sarasota County Court House, 2000 Main Street, Historic Courtroom, East Wing, Sarasota, Florida, at 9:00 a.m. on the 24TH day of JUNE, 2014.</p> <p>Karen E. Rushing Clerk Of The Circuit Court Sarasota County, Florida By: T. Lake, Deputy Clerk Publication Dates: MAY 23, 30; JUNE 6, 13, 2014 14-02279S</p>

FIRST INSERTION

NOTICE OF SALE IN THE CIRCUIT COURT OF THE TWELFTH JUDICIAL CIRCUIT OF THE STATE OF FLORIDA, IN AND FOR SARASOTA COUNTY CIVIL DIVISION

CASE NO. 58-2008-CA-009574-XXXX-NC
U.S. BANK NATIONAL ASSOCIATION, AS TRUSTEE FOR HARBORVIEW 2006-4 TRUST FUND,
Plaintiff, vs.
WILLIAM C. JONES; UNKNOWN SPOUSE OF WILLIAM C. JONES IF ANY; ANY AND ALL UNKNOWN PARTIES CLAIMING BY, THROUGH, UNDER, AND AGAINST THE HEREIN NAMED INDIVIDUAL DEFENDANT(S) WHO ARE NOT KNOWN TO BE DEAD OR ALIVE, WHETHER SAID UNKNOWN PARTIES MAY CLAIM AN INTEREST AS SPOUSES, HEIRS, DEVISEES, GRANTEEES OR OTHER CLAIMANTS; STATE OF FLORIDA, DEPARTMENT OF REVENUE; JOHN DOE AND JANE DOE AS UNKNOWN TENANTS IN POSSESSION;
Defendant(s)

Notice is hereby given that, pursuant to a Final Summary Judgment of Foreclosure entered on 10/29/2013 in the above styled cause, in the Circuit Court of Sarasota County, Florida, the office of Karen E. Rushing clerk of the circuit court will sell the property situate in Sarasota County, Florida, described as:

LOT 12, BLOCK 234, EIGHTH ADDITION TO PORT CHARLOTTE SUBDIVISION, AS PER PLAT THEREOF RECORDED IN PLAT BOOK 12, PAGE 20, 20A THROUGH 20Z2, OF THE PUBLIC RECORDS OF SARASOTA COUNTY, FLORIDA.

at public sale, to the highest and best bidder, for cash, www.sarasota.realforeclose.com at 9:00 o'clock, A.M., on June 18, 2014

Any person claiming an interest in the surplus from the sale, if any, other than the property owner as of the date of the lis pendens, must file a claim within 60 days after the sale.

If you are a person with a disability who needs any accommodation in order to participate in this proceeding, you are entitled, at no cost to you, to the provision of certain assistance. Please contact the Sarasota County Jury Office, P.O. Box 3079, Sarasota, Florida 34230-3079, (941)861-7400, at least seven (7) days before your scheduled court appearance, or immediately upon receiving this notification if the time before the scheduled appearance is less than seven (7) days; if you are hearing or voice impaired, call 711.

ATTORNEY FOR PLAINTIFF
 By /s/ Josh D. Donnelly
 Josh D. Donnelly
 Florida Bar #64788

Date: 05/17/2014
 THIS INSTRUMENT PREPARED BY:
 Law Offices Of Daniel C. Consuegra
 9204 King Palm Drive
 Tampa, FL 33619-1328
 Phone: 813-915-8660
 Attorneys for Plaintiff
 156850-T
 May 23, 30, 2014 14-02295S

FIRST INSERTION

RE-NOTICE OF FORECLOSURE SALE IN THE CIRCUIT COURT OF THE TWELFTH JUDICIAL CIRCUIT, IN AND FOR SARASOTA COUNTY, FLORIDA CIVIL DIVISION

CASE NO.: 2008 CA 009693 NC
PNC BANK, NATIONAL ASSOCIATION SUCCESSOR BY MERGER TO NATIONAL CITY BANK SUCCESSOR BY MERGER TO NATIONAL CITY BANK OF INDIANA DBA NATIONAL CITY MORTGAGE
Plaintiff, vs.
HUBERT WALKIEWICZ, et al
Defendants.
 RE-NOTICE IS HEREBY GIVEN pursuant to an Order Granting Plaintiff's Motion to Reschedule Foreclosure Sale filed May 8, 2014 and entered in Case No. 2008 CA 009693 NC of the Circuit Court of the TWELFTH Judicial Circuit in and for SARASOTA COUNTY, Florida, wherein PNC BANK, NATIONAL ASSOCIATION SUCCESSOR BY MERGER TO NATIONAL CITY BANK SUCCESSOR BY MERGER TO NATIONAL CITY BANK OF INDIANA DBA NATIONAL CITY MORTGAGE, is Plaintiff, and HUBERT WALKIEWICZ, et al are Defendants, the clerk will sell to the highest and best bidder for cash, beginning at 09:00 AM at www.sarasota.realforeclose.com, in accordance with Chapter 45, Florida Statutes, on the 12 day of June, 2014, the following described property as set forth in said Lis Pendens, to wit:

LOT 18, Block 698, of 17th Addition to Port Charlotte Subdivision, according to the Plat thereof, as recorded in Plat Book 13, Page 16, or the Public Records of Sarasota County, Florida.

Any person claiming an interest in the surplus funds from the sale, if any, other than the property owner as of the date of the lis pendens must file a claim within 60 days after the sale.

If you are a person with a disability who needs any accommodation in order to participate in this proceeding, you are entitled, at no cost to you, to the provision of certain assistance.

Please contact the Sarasota County Jury Office, P.O. Box 3079, Sarasota, Florida 34230-3079, (941)861-7400, at least seven (7) days before your scheduled court appearance, or immediately upon receiving this notification if the time before the scheduled appearance is less than seven (7) days; if you are hearing or voice impaired, call 711.

Dated: May 19, 2014
 By: /s/ Heather Griffiths
 Phelan Hallinan, PLC
 Heather Griffiths, Esq.,
 Florida Bar No. 0091444
 Emilio R. Lenzi, Esq.,
 Florida Bar No. 0668273

Phelan Hallinan, PLC
 Attorneys for Plaintiff
 2727 West Cypress Creek Road
 Ft. Lauderdale, FL 33309
 Tel: 954-462-7000
 Fax: 954-462-7001
 Service by email:
 FL.Service@PhelanHallinan.com
 PH # 47910
 May 23, 30, 2014 14-02303S

FIRST INSERTION

NOTICE OF FORECLOSURE SALE IN THE CIRCUIT COURT OF THE TWELFTH JUDICIAL CIRCUIT, IN AND FOR SARASOTA COUNTY, FLORIDA

CASE NO. 2009 CA 016241 NC
THE BANK OF NEW YORK MELLON FKA THE BANK OF NEW YORK, AS TRUSTEE FOR THE CERTIFICATEHOLDERS CWALT, INC., ALTERNATIVE LOAN TRUST 2006-21CB, MORTGAGE PASS-THROUGH CERTIFICATES, SERIES 2006-21CB,
Plaintiff, vs.
CARMEN CERVINO; PABLO CERVINO, et al.
Defendants
 NOTICE IS HEREBY GIVEN pursuant to a Final Judgment of Foreclosure dated April 23, 2014, and entered in Case No. 2009 CA 016241 NC, of the Circuit Court of the Twelfth Judicial Circuit in and for SARASOTA County, Florida. THE BANK OF NEW YORK MELLON FKA THE BANK OF NEW YORK, AS TRUSTEE FOR THE CERTIFICATEHOLDERS CWALT, INC., ALTERNATIVE LOAN TRUST 2006-21CB, MORTGAGE PASS-THROUGH CERTIFICATES, SERIES 2006-21CB, is Plaintiff and CARMEN CERVINO; PABLO CERVINO; CEDAR GROVE HOMEOWNERS ASSOCIATION, INC.; CITIFINANCIAL EQUITY SERVICES, INC., are defendants. The Clerk of Court will sell to the highest and best bidder for cash via the Internet at www.sarasota.realforeclose.com, at 9:00 a.m., on the 23rd day of June, 2014, the following described property as set forth in said Final Judgment, to wit:

LOT 1, BLOCK C, FIRST ADDITION TO CEDAR GROVE, ACCORDING TO THE PLAT THEREOF RECORDED IN PLAT BOOK 1, PAGE 65 OF THE PUBLIC RECORDS OF SARASOTA COUNTY, FLORIDA.

Any person claiming an interest in the surplus from the sale, if any, other than the property owner as of the date of the Lis Pendens must file a claim within 60 days after the sale.

If you are a person with a disability who needs any accommodation in order to participate in this proceeding, you are entitled, at no cost to you, to the provision of certain assistance. Please contact the Sarasota County Jury Office, P.O. Box 3079, Sarasota, Florida 34230-3079, (941)861-7400, at least seven (7) days before your scheduled court appearance, or immediately upon receiving this notification if the time before the scheduled appearance is less than seven (7) days; if you are hearing or voice impaired, call 711.

Mark C. Elia, Esq.
 Florida Bar #: 695734
 Email: MCElia@vanlawfl.com
 VAN NESS LAW FIRM, PLC
 1239 N. Newport Center Drive,
 Suite 110
 Deerfield Beach, Florida 33442
 Ph: (954) 571-2031
 Fax: (954) 571-2033
 PRIMARY EMAIL:
 Pleadings@vanlawfl.com
 May 23, 30, 2014 14-02306S

FIRST INSERTION

NOTICE OF FORECLOSURE SALE IN THE CIRCUIT COURT OF THE 12TH JUDICIAL CIRCUIT, IN AND FOR SARASOTA COUNTY, FLORIDA

CIVIL DIVISION:
CASE NO.: 2013 CA 004554 NC
JPMORGAN CHASE BANK, NATIONAL ASSOCIATION, SUCCESSOR BY MERGER TO CHASE HOME FINANCE LLC,
Plaintiff, vs.
ATHANASIOS MARKADAKIS; ANNA MARKADAKIS; UNKNOWN TENANT IN POSSESSION OF THE SUBJECT PROPERTY,
Defendants.
 NOTICE IS HEREBY GIVEN pursuant to Final Judgment of Foreclosure dated the 12th day of May, 2014, and entered in Case No. 2013 CA 004554 NC, of the Circuit Court of the 12TH Judicial Circuit in and for Sarasota County, Florida, wherein U.S. BANK NATIONAL ASSOCIATION NOT IN ITS INDIVIDUAL CAPACITY, BUT SOLELY AS LEGAL TITLE TRUSTEE FOR LVS TITLE TRUST I is the Plaintiff and ATHANASIOS MARKADAKIS; ANNA MARKADAKIS and UNKNOWN TENANT (S) IN POSSESSION OF THE SUBJECT PROPERTY are defendants. The Clerk of this Court shall sell to the highest and best bidder for cash electronically at www.sarasota.realforeclose.com at 9:00 AM on the 16th day of June, 2014, the following described property as set forth in said Final Judgment, to wit:

LOTS 3348 AND 3349, SOUTH VENICE, UNIT NO. 12, ACCORDING TO THE PLAT THEREOF, AS RECORDED IN PLAT BOOK 6, PAGE 48, OF THE PUBLIC RECORDS OF SARASOTA COUNTY, FLORIDA

ANY PERSON CLAIMING AN INTEREST IN THE SURPLUS FROM THE SALE, IF ANY, OTHER THAN THE PROPERTY OWNER AS OF THE DATE OF THE LIS PENDENS MUST FILE A CLAIM WITHIN 60 DAYS AFTER THE SALE.

If you are a person with a disability who needs any accommodation in order to participate in this proceeding, you are entitled, at no cost to you, to the provision of certain assistance. Please contact the Sarasota County Jury Office, P.O. Box 3079, Sarasota, Florida 34230-3079, (941)861-7400, at least seven (7) days before your scheduled court appearance, or immediately upon receiving this notification if the time before the scheduled appearance is less than seven (7) days; if you are hearing or voice impaired, call 711.

Dated this 19 day of May, 2014.
 By: Jennifer Nicole Tarquinio
 Bar #99192

Choice Legal Group, P.A.
 P.O. Box 9908
 Fort Lauderdale, FL 33310-0908
 Telephone: (954) 453-0365
 Facsimile: (954) 771-6052
 Toll Free: 1-800-441-2438
 DESIGNATED PRIMARY E-MAIL FOR SERVICE PURSUANT TO FLA R. JUD. ADMIN 2.516
 eservice@clegalgroup.com
 11-07168
 May 23, 30, 2014 14-02314S

FIRST INSERTION

NOTICE OF SALE IN THE CIRCUIT CIVIL COURT OF THE TWELFTH JUDICIAL CIRCUIT OF FLORIDA, IN AND FOR SARASOTA COUNTY CIVIL DIVISION

Case No. 58-2010-CA-006383 NC
Division C
WELLS FARGO BANK, N.A.
Plaintiff, vs.
SAMUEL ISRAEL KAPLAN; PELE PARSONS WYLDE; PELE PARSONS WYLDE, TRUSTEE OF THE PELE PARSONS WYLDE TRUST DATED APRIL 26, 2002; UNKNOWN BENEFICIARY OF THE PELE PARSONS WYLDE TRUST DATED APRIL 26, 2002; UNKNOWN TRUSTEE OF THE PELE PARSONS WYLDE TRUST DATED APRIL 26, 2002, WELLS FARGO BANK, N.A.; UNKNOWN SPOUSE OF PELE PARSONS WYLDE; UNKNOWN SPOUSE OF SAMUEL ISRAEL KAPLAN, AND UNKNOWN TENANTS/OWNERS,
Defendants.
 Notice is hereby given, pursuant to Final Judgment of Foreclosure for Plaintiff entered in this cause on June 3, 2013, in the Circuit Court of Sarasota County, Florida, The Clerk of the Court will sell the property situated in Sarasota County, Florida described as:

LOTS 20 AND 21, BLOCK 13, SARASOTA BEACH, ACCORDING TO THE PLAT THEREOF, RECORDED IN PLAT BOOK 1, PAGES 76 THROUGH 81, OF THE PUBLIC RECORDS OF SARASOTA COUNTY, FLORIDA.

and commonly known as: 425 AVENIDA DEL NORTE, SARASOTA, FL 34242; including the building, appurtenances, and fixtures located therein, at public sale, to the highest and best bidder, for cash, Sales are held online at: <https://www.sarasota.realforeclose.com>, on June 16, 2014 at 9:00 A.M.

Any persons claiming an interest in the surplus from the sale, if any, other than the property owner as of the date of the lis pendens must file a claim within 60 days after the sale.

If you are a person with a disability who needs any accommodation in order to participate in this proceeding, you are entitled, at no cost to you, to the provision of certain assistance. Please contact the Sarasota County Jury Office, P.O. Box 3079, Sarasota, Florida 34230-3079, (941)861-7400, at least seven (7) days before your scheduled court appearance, or immediately upon receiving this notification if the time before the scheduled appearance is less than seven (7) days; if you are hearing or voice impaired, call 711.

Karen E. Rushing
 By: Frances Grace Cooper, Esquire
 Attorney for Plaintiff
 Edward B. Pritchard
 (813) 229-0900 x1309
 Kass Shuler, P.A.
 P.O. Box 800
 Tampa, FL 33601-0800
 ForeclosureService@kasslaw.com
 317300/1007880/
 May 23, 30, 2014 14-02318S

FIRST INSERTION

NOTICE OF RESCHEDULED FORECLOSURE SALE IN THE CIRCUIT COURT OF THE TWELFTH JUDICIAL CIRCUIT IN AND FOR SARASOTA COUNTY, FLORIDA CIVIL ACTION

CASE NO.: 2007 CA 012568 NC
DIVISION: C
SOUTHTRUST MORTGAGE, Plaintiff, vs.
GABRIEL REED , et al,
Defendant(s).
 NOTICE IS HEREBY GIVEN pursuant to an Order Rescheduling Foreclosure Sale dated May 7, 2014 and entered in Case No. 2007 CA 012568 NC of the Circuit Court of the TWELFTH Judicial Circuit in and for SARASOTA County, Florida wherein WELLS FARGO BANK, NA, Plaintiff name has changed pursuant to order previously entered, is the Plaintiff and GABRIEL REED; ANY AND ALL UNKNOWN PARTIES CLAIMING BY, THROUGH, UNDER, AND AGAINST THE HEREIN NAMED INDIVIDUAL DEFENDANT(S) WHO ARE NOT KNOWN TO BE DEAD OR ALIVE, WHETHER SAID UNKNOWN PARTIES MAY CLAIM AN INTEREST AS SPOUSES, HEIRS, DEVISEES, GRANTEEES, OR OTHER CLAIMANTS; STATE OF FLORIDA - DEPARTMENT OF REVENUE; TENANT #1; TENANT #2 are the Defendants, The Clerk will sell to the highest and best bidder for cash at WWW.SARASOTA.REALFORECLOSE.COM at 9:00AM, on 06/19/2014, the following described property as set forth in said Final Judgment:

THE EAST 100 FEET OF THE SOUTH 1/2 OF LOT 3, BLOCK A, RIVERSIDE PARK, RECORDED IN PLAT BOOK 1, PAGE 13, OF THE PUBLIC RECORDS OF SARASOTA COUNTY, FLORIDA

A/K/A 3061 WEST PLACE, SARASOTA, FL 34234
 Any person claiming an interest in the surplus from the sale, if any, other than the property owner as of the date of the Lis Pendens must file a claim within sixty (60) days after the sale.

If you are a person with a disability who needs any accommodation in order to participate in this proceeding, you are entitled, at no cost to you, to the provision of certain assistance. Please contact the Sarasota County Jury Office, P.O. Box 3079, Sarasota, Florida 34230-3079, (941)861-7400, at least seven (7) days before your scheduled court appearance, or immediately upon receiving this notification if the time before the scheduled appearance is less than seven (7) days; if you are hearing or voice impaired, call 711.

By: Amy Recla
 Florida Bar No. 102811
 Ronald R Wolfe & Associates, P.L.
 P.O. Box 25018
 Tampa, Florida 33622-5018
 (813) 251-4766
 (813) 251-1541 Fax
 F07046511
 May 23, 30, 2014 14-02307S

FIRST INERTION

RE-NOTICE OF FORECLOSURE SALE IN THE CIRCUIT COURT OF THE TWELFTH JUDICIAL CIRCUIT, IN AND FOR SARASOTA COUNTY, FLORIDA CIVIL DIVISION

CASE NO.: 2012 CA 004077 NC
U.S. BANK NATIONAL ASSOCIATION, AS TRUSTEE FOR CREDIT SUISSE FIRST BOSTON MORTGAGE SECURITIES CORP., CSAB MORTGAGE-BACKED TRUST 2006-3, CSAB MORTGAGE-BACKED PASS-THROUGH CERTIFICATES, 2006-3,
Plaintiff, vs.
ARTHUR LEITC FRANCO, et al
Defendants.
 RE-NOTICE IS HEREBY GIVEN pursuant to an Order Granting Plaintiff's Motion to Reschedule Foreclosure Sale filed May 5, 2014 and entered in Case No. 2012 CA 004077 NC of the Circuit Court of the TWELFTH Judicial Circuit in and for SARASOTA COUNTY, Florida, wherein U.S. BANK NATIONAL ASSOCIATION, AS TRUSTEE FOR CREDIT SUISSE FIRST BOSTON MORTGAGE SECURITIES CORP., CSAB MORTGAGE-BACKED TRUST 2006-3, CSAB MORTGAGE-BACKED PASS-THROUGH CERTIFICATES, 2006-3, is Plaintiff, and ARTHUR LEITC FRANCO, et al are Defendants, the clerk will sell to the highest and best bidder for cash, beginning at 09:00 AM at www.sarasota.realforeclose.com, in accordance with Chapter 45, Florida Statutes, on the 12 day of June, 2014, the following described property as set forth in said Lis Pendens, to wit:

Lot 1552, Lake Sarasota, Unit # 17 Subdivision according to the Plat thereof, as recorded in Plat Book 9, Page 23, Public Records of Sarasota County, Florida.

Any person claiming an interest in the surplus funds from the sale, if any, other than the property owner as of the date of the lis pendens must file a claim within 60 days after the sale.

If you are a person with a disability who needs any accommodation in order to participate in this proceeding, you are entitled, at no cost to you, to the provision of certain assistance. Please contact the Sarasota County Jury Office, P.O. Box 3079, Sarasota, Florida 34230-3079, (941)861-7400, at least seven (7) days before your scheduled court appearance, or immediately upon receiving this notification if the time before the scheduled appearance is less than seven (7) days; if you are hearing or voice impaired, call 711.

Dated: May 19, 2014
 By: /s/ Heather Griffiths
 Phelan Hallinan, PLC
 Heather Griffiths, Esq.,
 Florida Bar No. 0091444
 Emilio R. Lenzi, Esq.,
 Florida Bar No. 0668273

FIRST INERTION

RE-NOTICE OF FORECLOSURE SALE IN THE CIRCUIT COURT OF THE 12TH JUDICIAL CIRCUIT, IN AND FOR SARASOTA COUNTY, FLORIDA CIVIL DIVISION

CASE NO.: 2012 CA 008063 NC
CITIMORTGAGE, INC., Plaintiff, vs.
EDWIN F. GRISALES; CITY OF SARASOTA, A MUNICIPAL CORPORATION; GLORIA INES CARDONA; CAROLINA GRISALES; JESUS GRISALES A/K/A JESUS M. GRISALES; UNKNOWN TENANT IN POSSESSION OF THE SUBJECT PROPERTY,
Defendants.
 NOTICE IS HEREBY GIVEN pursuant to an Order Resetting Foreclosure Sale dated the 17th day of April, 2014, and entered in Case No. 2012 CA 008063 NC, of the Circuit Court of the 12TH Judicial Circuit in and for Sarasota County, Florida, wherein CITIMORTGAGE, INC. is the Plaintiff and EDWIN F. GRISALES; CITY OF SARASOTA, A MUNICIPAL CORPORATION; GLORIA INES CARDONA; CAROLINA GRISALES; JESUS GRISALES A/K/A JESUS M. GRISALES and UNKNOWN TENANT (S) IN POSSESSION OF THE SUBJECT PROPERTY are defendants. The Clerk of this Court shall sell to the highest and best bidder for cash electronically at www.sarasota.realforeclose.com at 9:00 AM on the 16th day of June, 2014, the following described property as set forth in said Final Judgment, to wit:

LOT 19, BLOCK 1934, 41ST

Choice Legal Group, P.A.
 P.O. Box 9908
 Fort Lauderdale, FL 33310-0908
 Telephone: (954) 453-0365
 Facsimile: (954) 771-6052
 Toll Free: 1-800-441-2438
 DESIGNATED PRIMARY E-MAIL FOR SERVICE PURSUANT TO FLA R. JUD. ADMIN 2.516
 eservice@clegalgroup.com
 12-10459
 May 23, 30, 2014 14-02313S

FIRST INERTION

NOTICE OF SALE IN THE CIRCUIT CIVIL COURT OF THE TWELFTH JUDICIAL CIRCUIT OF FLORIDA, IN AND FOR SARASOTA COUNTY CIVIL DIVISION

Case No. 58-2013-CA-002781 NC
Division A
JPMORGAN CHASE BANK, NATIONAL ASSOCIATION, Plaintiff, vs.
LEON F. BOOKER, STONEYBROOK VERANDA GREENS I ASSOCIATION, INC., STONEYBROOK VERANDA GREENS COMMONS ASSOCIATION, INC., STONEYBROOK GOLF & COUNTRY CLUB OF SARASOTA, INC., FLORIDA SOUTHERN ROOFING & SHEET METAL, INC., AND UNKNOWN TENANTS/ OWNERS,
Defendants.
 Notice is hereby given, pursuant to Final Judgment of Foreclosure for Plaintiff entered in this cause on May 12, 2014, in the Circuit Court of Sarasota County, Florida, The Clerk of the Court will sell the property situated in Sarasota County, Florida described as:

UNIT 1423, BUILDING 1400, OF STONEYBROOK VERANDA GREENS CONDOMINIUM I, A CONDOMINIUM, ACCORDING TO THE DECLARATION THEREOF, AS RECORDED IN OFFICIAL RECORDS BOOK 2839, AT PAGE(S) 1750, AND AS PER PLAT THEREOF RECORDED IN CONDOMINIUM BOOK

31, PAGES 27, 27A AND 27B, OF THE PUBLIC RECORDS OF SARASOTA COUNTY, FLORIDA.
 and commonly known as: 9540 HIGH GATE DR UNIT 1423, SARASOTA, FL 34238; including the building, appurtenances, and fixtures located therein, at public sale, to the highest and best bidder, for cash, Sales are held online at: <https://www.sarasota.realforeclose.com>, on June 16, 2014 at 9:00 A.M.

Any persons claiming an interest in the surplus from the sale, if any, other than the property owner as of the date of the lis pendens must file a claim within 60 days after the sale.

If you are a person with a disability who needs any accommodation in order to participate in this proceeding, you are entitled, at no cost to you, to the provision of certain assistance. Please contact the Sarasota County Jury Office, P.O. Box 3079, Sarasota, Florida 34230-3079, (941)861-7400, at least seven (7) days before your scheduled court appearance, or immediately upon receiving this notification if the time before the scheduled appearance is less than seven (7) days; if you are hearing or voice impaired, call 711.

Karen E. Rushing
 By: Frances Grace Cooper, Esquire
 Attorney for Plaintiff
 Edward B. Pritchard
 (813) 229-0900 x1309
 Kass Shuler, P.A.
 P.O. Box 800
 Tampa, FL 33601-0800
 ForeclosureService@kasslaw.com
 320400/1332602/
 May 23, 30, 2014 14-02315S

SAVE TIME
 E-mail your Legal Notice **legal@businessobserverfl.com**
 Wednesday Noon Deadline • Friday Publication
Business Observer
 LV4681

FIRST INSERTION

NOTICE OF FORECLOSURE SALE IN THE CIRCUIT COURT OF THE TWELFTH JUDICIAL CIRCUIT IN AND FOR SARASOTA COUNTY, FLORIDA
CIVIL ACTION
CASE NO.: 2014 CA 000631 NC
DIVISION: C

WELLS FARGO BANK, NA,
Plaintiff, vs.
PATRICIA A. ROSS, et al,
Defendant(s).

NOTICE IS HEREBY GIVEN pursuant to a Final Judgment of Mortgage Foreclosure dated May 12, 2014 and entered in Case No. 2014 CA 000631 NC of the Circuit Court of the TWELFTH JUDICIAL CIRCUIT in and for SARASOTA County, Florida wherein WELLS FARGO BANK, NA is the Plaintiff and PATRICIA A. ROSS; are the Defendants, The Clerk will sell to the highest and best bidder for cash at WWW.SARASOTA.REALFORECLOSE.COM at 9:00AM, on the 18th day of June, 2014, the following described property as set forth in said Final Judgment:

LOT 14, BLOCK 221, VENICE, NORTH EDGEWOOD SECTION, ACCORDING TO THE PLAT THEREOF RECORDED IN PLAT BOOK 3, PAGE 8, OF THE PUBLIC RECORDS OF SARASOTA COUNTY, FLORIDA.

A/K/A 1004 LAUREL AVENUE, VENICE, FL 34285-7818

Any person claiming an interest in the surplus from the sale, if any, other than the property owner as of the date of the Lis Pendens must file a claim within sixty (60) days after the sale.

If you are a person with a disability who needs any accommodation in order to participate in this proceeding, you are entitled, at no cost to you, to the provision of certain assistance. Please contact the Sarasota County Jury Office, P.O. Box 3079, Sarasota, Florida 34230-3079, (941)861-7400, at least seven (7) days before your scheduled court appearance, or immediately upon receiving this notification if the time before the scheduled appearance is less than seven (7) days; if you are hearing or voice impaired, call 711.

Karen E. Rushing
By: Frances Grace Cooper, Esquire
Attorney for Plaintiff
Edward B. Pritchard
(813) 229-0900 x1309
Kass Shuler, P.A.
P.O. Box 800
Tampa, FL 33601-0800
ForeclosureService@kasslaw.com
200850/1119414/
May 23, 30, 2014 14-02248S

FIRST INSERTION

NOTICE OF SALE IN THE CIRCUIT CIVIL COURT OF THE TWELFTH JUDICIAL CIRCUIT OF FLORIDA, IN AND FOR SARASOTA COUNTY CIVIL DIVISION
Case No. 58-2012-CA-009806 NC
Division C

JPMORGAN CHASE BANK, NATIONAL ASSOCIATION
Plaintiff, vs.
JEFFREY P. INTERBITZEN A/K/A JEFFREY INTERBITZEN AND UNKNOWN TENANTS/OWNERS,
Defendants.

Notice is hereby given, pursuant to Final Judgment of Foreclosure for Plaintiff entered in this cause on July 22, 2013, in the Circuit Court of Sarasota County, Florida, The Clerk of the Court will sell the property situated in Sarasota County, Florida described as:

LOT 19, BLOCK 3 OF CENTRAL PARK SUBDIVISION, NO.1, ACCORDING TO THE PLAT THEREOF AS RECORDED IN PLAT BOOK 1, PAGE(S) 1, OF THE PUBLIC RECORDS OF SARASOTA COUNTY, FLORIDA.

and commonly known as: 1709 4TH ST, SARASOTA, FL 34236; including the building, appurtenances, and fixtures located therein, at public sale, to the highest and best bidder, for cash, Sales are held online at: <https://www.sarasota.realforeclose.com>, on June 11, 2014 at 9:00 A.M..

Any persons claiming an interest in the surplus from the sale, if any, other than the property owner as of the date of the lis pendens must file a claim within 60 days after the sale.

If you are a person with a disability who needs any accommodation in order to participate in this proceeding, you are entitled, at no cost to you, to the provision of certain assistance. Please contact the Sarasota County Jury Office, P.O. Box 3079, Sarasota, Florida 34230-3079, (941)861-7400, at least seven (7) days before your scheduled court appearance, or immediately upon receiving this notification if the time before the scheduled appearance is less than seven (7) days; if you are hearing or voice impaired, call 711.

Karen E. Rushing
By: Frances Grace Cooper, Esquire
Attorney for Plaintiff
Edward B. Pritchard
(813) 229-0900 x1309
Kass Shuler, P.A.
P.O. Box 800
Tampa, FL 33601-0800
ForeclosureService@kasslaw.com
200850/1119414/
May 23, 30, 2014 14-02253S

FIRST INSERTION

NOTICE OF FORECLOSURE SALE IN THE CIRCUIT COURT OF THE TWELFTH JUDICIAL CIRCUIT IN AND FOR SARASOTA COUNTY, FLORIDA
CIVIL ACTION
CASE NO.: 58-2013-CA-006496-NC
DIVISION: C

WELLS FARGO BANK, NA,
Plaintiff, vs.
MIKE KRSTEC, et al,
Defendant(s).

NOTICE IS HEREBY GIVEN pursuant to a Final Judgment of Mortgage Foreclosure dated May 12, 2014 and entered in Case No. 58-2013-CA-006496-NC of the Circuit Court of the TWELFTH JUDICIAL CIRCUIT in and for SARASOTA County, Florida wherein WELLS FARGO BANK, NA is the Plaintiff and MIKE KRSTEC; SUSAN R KRSTEC; TENANT #1 N/K/A MICHAEL KRSTEC are the Defendants, The Clerk will sell to the highest and best bidder for cash at WWW.SARASOTA.REALFORECLOSE.COM at 9:00AM, on the 16th day of June, 2014, the following described property as set forth in said Final Judgment:

LOT 9, BLOCK 1279 OF 26TH ADDITION TO PORT CHARLOTTE SUBDIVISION, A SUBDIVISION ACCORDING TO THE PLAT THEREOF, AS RECORDED IN PLAT BOOK 15, PAGE 3, OF THE PUBLIC RECORDS OF SARASOTA COUNTY, FLORIDA.

A/K/A 3262 ROGUE STREET, NORTH PORT, FL 34291

Any person claiming an interest in the surplus from the sale, if any, other than the property owner as of the date of the Lis Pendens must file a claim within sixty (60) days after the sale.

If you are a person with a disability who needs any accommodation in order to participate in this proceeding, you are entitled, at no cost to you, to the provision of certain assistance. Please contact the Sarasota County Jury Office, P.O. Box 3079, Sarasota, Florida 34230-3079, (941)861-7400, at least seven (7) days before your scheduled court appearance, or immediately upon receiving this notification if the time before the scheduled appearance is less than seven (7) days; if you are hearing or voice impaired, call 711.

Amy Recla
By: Amy Recla
Florida Bar No. 102811
Ronald R Wolfe & Associates, P.L.
P.O. Box 25018
Tampa, Florida 33622-5018
(813) 251-4766
(813) 251-1541 Fax
F13012074
May 23, 30, 2014 14-02246S

FIRST INSERTION

NOTICE OF FORECLOSURE SALE IN THE CIRCUIT COURT OF THE TWELFTH JUDICIAL CIRCUIT IN AND FOR SARASOTA COUNTY, FLORIDA
CIVIL ACTION
CASE NO.: 58-2013-CA-006916 NC
DIVISION: C

WELLS FARGO BANK, N.A.,
Plaintiff, vs.
REGAN E. PATON A/K/A REGAN PATON, et al,
Defendant(s).

NOTICE IS HEREBY GIVEN pursuant to a Final Judgment of Mortgage Foreclosure dated May 12, 2014 and entered in Case No. 58-2013-CA-006916 NC of the Circuit Court of the TWELFTH JUDICIAL CIRCUIT in and for SARASOTA County, Florida wherein WELLS FARGO BANK, N.A. is the Plaintiff and REGAN E. PATON A/K/A REGAN PATON; BRANCH BANKING AND TRUST COMPANY; PINE MEADOW ASSOCIATION, INC.; are the Defendants, The Clerk will sell to the highest and best bidder for cash at WWW.SARASOTA.REALFORECLOSE.COM at 9:00AM, on the 17th day of June, 2014, the following described property as set forth in said Final Judgment:

LOT 15, PINE MEADOW SUBDIVISION, ACCORDING TO THE MAP OR PLAT THEREOF AS RECORDED IN PLAT BOOK 24, PAGE 17, OF THE PUBLIC RECORDS OF SARASOTA COUNTY, FLORIDA.

A/K/A 4103 PINE MEADOW TERRACE, SARASOTA, FL 34233-3640

Any person claiming an interest in the surplus from the sale, if any, other than the property owner as of the date of the Lis Pendens must file a claim within sixty (60) days after the sale.

If you are a person with a disability who needs any accommodation in order to participate in this proceeding, you are entitled, at no cost to you, to the provision of certain assistance. Please contact the Sarasota County Jury Office, P.O. Box 3079, Sarasota, Florida 34230-3079, (941)861-7400, at least seven (7) days before your scheduled court appearance, or immediately upon receiving this notification if the time before the scheduled appearance is less than seven (7) days; if you are hearing or voice impaired, call 711.

Amy Recla
By: Matthew Wolf
Florida Bar No. 102811
Ronald R Wolfe & Associates, P.L.
P.O. Box 25018
Tampa, Florida 33622-5018
(813) 251-4766
(813) 251-1541 Fax
F13013166
May 23, 30, 2014 14-02247S

FIRST INSERTION

NOTICE OF FORECLOSURE SALE IN THE CIRCUIT COURT OF THE TWELFTH JUDICIAL CIRCUIT IN AND FOR SARASOTA COUNTY, FLORIDA
CIVIL ACTION
CASE NO.: 58-2013-CA-006355-NC
DIVISION: A

WELLS FARGO BANK, NA,
Plaintiff, vs.
MICHAEL S DART, et al,
Defendant(s).

NOTICE IS HEREBY GIVEN pursuant to a Final Judgment of Mortgage Foreclosure dated May 12, 2014 and entered in Case No. 58-2013-CA-006355-NC of the Circuit Court of the TWELFTH JUDICIAL CIRCUIT in and for SARASOTA County, Florida wherein WELLS FARGO BANK, NA is the Plaintiff and MICHAEL S DART; JENNIFER A DART; BANK OF AMERICA, NA; TENANT #1 N/K/A SCOTT A. MARTIN, and TENANT #2 N/K/A HEATHER ASHTON are the Defendants, The Clerk will sell to the highest and best bidder for cash at WWW.SARASOTA.REALFORECLOSE.COM at 9:00AM, on the 17th day of June, 2014, the following described property as set forth in said Final Judgment:

LOT 13, BLOCK 137, 8TH ADDITION TO PORT CHARLOTTE SUBDIVISION, ACCORDING TO THE PLAT THEREOF RECORDED IN PLAT BOOK 12, PAGE 20, OF THE PUBLIC RECORDS OF SARASOTA COUNTY, FLORIDA.

A/K/A 2228 BONANZA LANE, NORTH PORT, FL 34286-1109

Any person claiming an interest in the surplus from the sale, if any, other than the property owner as of the date of the Lis Pendens must file a claim within sixty (60) days after the sale.

If you are a person with a disability who needs any accommodation in order to participate in this proceeding, you are entitled, at no cost to you, to the provision of certain assistance. Please contact the Sarasota County Jury Office, P.O. Box 3079, Sarasota, Florida 34230-3079, (941)861-7400, at least seven (7) days before your scheduled court appearance, or immediately upon receiving this notification if the time before the scheduled appearance is less than seven (7) days; if you are hearing or voice impaired, call 711.

Amy Recla
By: Amy Recla
Florida Bar No. 102811
Ronald R Wolfe & Associates, P.L.
P.O. Box 25018
Tampa, Florida 33622-5018
(813) 251-4766
(813) 251-1541 Fax
F13011443
May 23, 30, 2014 14-02244S

FIRST INSERTION

NOTICE OF FORECLOSURE SALE IN THE CIRCUIT COURT OF THE 12TH JUDICIAL CIRCUIT, IN AND FOR SARASOTA COUNTY, FLORIDA
CIVIL DIVISION
CASE NO. 2013 CA 004570 NC
FEDERAL NATIONAL MORTGAGE ASSOCIATION
Plaintiff, vs.
SHANE BUNDY; ET AL;
Defendants,

NOTICE IS HEREBY GIVEN pursuant to a Final Judgment of Foreclosure dated May 12, 2014, and entered in Case No. 2013 CA 004570 NC, of the Circuit Court of the 12th Judicial Circuit in and for SARASOTA County, Florida, wherein FEDERAL NATIONAL MORTGAGE ASSOCIATION is Plaintiff and SHANE BUNDY; MACHELL BUNDY; UNKNOWN PERSON(S) IN POSSESSION OF THE SUBJECT PROPERTY; JOCKEY CLUB OF NORTH PORT PROPERTY OWNERS' ASSOCIATION INC.; are defendants. The Clerk of Court will sell to the highest and best bidder for cash BY ELECTRONIC SALE AT: WWW.SARASOTA.REALFORECLOSE.COM, at 9:00 A.M., on the 17 day of June, 2014, the following described property as set forth in said Final Judgment, to wit:

LOT 12, BLOCK 2631, 52ND ADDITION TO PORT CHARLOTTE SUBDIVISION, ACCORDING TO THE PLAT THEREOF, RECORDED IN PLAT BOOK 21, PAGE 13, OF THE PUBLIC RECORDS OF SARASOTA COUNTY, FLORIDA.

A person claiming an interest in the surplus from the sale, if any, other than the property owner as of the date of the lis pendens must file a claim within 60 days after the sale.

If you are a person with a disability who needs any accommodation in order to participate in this proceeding, you are entitled, at no cost to you, to the provision of certain assistance. Please contact the Sarasota County Jury Office, P.O. Box 3079, Sarasota, Florida 34230-3079, (941)861-7400, at least seven (7) days before your scheduled court appearance, or immediately upon receiving this notification if the time before the scheduled appearance is less than seven (7) days; if you are hearing or voice impaired, call 711.

Dated this 16 day of May, 2014.
Eric M. Knopp, Esq.
Bar No.: 709921

Submitted by:
Kahane & Associates, P.A.
8201 Peters Road,
Ste.3000
Plantation, FL 33324
Telephone: (954) 382-3486
Telefacsimile: (954) 382-5380
Designated service email:
notice@kahaneandassociates.com
File No.: 13-01671 SET
V1.20140101
May 23, 30, 2014 14-02298S

FIRST INERTION

NOTICE OF TERMINATION OF GUARDIANSHIP IN THE CIRCUIT COURT FOR SARASOTA COUNTY, FLORIDA PROBATE DIVISION
File No. 2013-GA-002128 NC
IN RE: GUARDIANSHIP OF JOHN CHRISTIAN NEEL

The administration of the Guardianship of JOHN CHRISTIAN NEEL, File Number 2013-GA-002128, is currently pending in the Circuit Court for Sarasota County, Florida, Probate Division, the address of which is P.O. Box 3079, Sarasota, Florida 34230. The name and address of the court appointed successor co-guardians are JENNIFER NEEL and MELISSA BETH WEAVER, c/o P.O. Box 3018, Sarasota, Florida 34230. The name and address of the co-guardians' attorney are set forth below.

JENNIFER NEEL and MELISSA BETH WEAVER have been appointed as the co-guardians of JOHN CHRISTIAN NEEL by a court of competent jurisdiction, in Bergen County, New Jersey, Case No. P-503-13. The co-guardians' addresses are 1 Circle Lane, Rutherford, New Jersey 07070, and 6001 Crystal Springs Court, Greensboro, North Carolina 27410, respectively, and the name and address of the co-guardians' attorney are SHIRLEY B. WHITENACK, ESQ., 220 Park Avenue, P.O. Box 991, Florham Park, New Jersey 07932.

ALL INTERESTED PERSONS ARE NOTIFIED THAT:

A Petition for Discharge has been filed upon the grounds of a change of domicile for the Ward. Thirty days from the date of the first publication of this notice, the co-guardians will apply for discharge. At that time, the jurisdiction of the Ward will be transferred to Bergen County, New Jersey.

All persons on whom this notice is served who have objections to the discharge of the co-guardians shall file such objections with this court WITHIN THE LATER OF THIRTY DAYS FROM THE DATE OF SERVICE OF THE PETITION FOR DISCHARGE OR THE DATE OF THE FIRST PUBLICATION OF NOTICE.

Any objection shall be in writing and shall state with particularity each item to which the objection is directed and the grounds on which the objection is based. Within ninety days after the filing of an objection, a notice of hearing thereon shall be served or the objection shall be abandoned. ALL OBJECTIONS NOT SO FILED WILL BE FOREVER BARRED.

The date of the first publication of this Notice is May 23, 2014.

JENNIFER NEEL
c/o P.O. Box 3018
Sarasota, Florida 34230
Co-Guardians
MELISSA BETH WEAVER
c/o P.O. Box 3018
Sarasota, Florida 34230
Co-Guardians
Attorney for Co-Guardians:
MATTHEW B. MAYPER
Florida Bar No. 0956820
FERGUSON, SKIPPER, SHAW,
KEYSER, BARON & TIRABASSI, P.A.
1515 Ringling Boulevard,
10th Floor
P.O. Box 3018
Sarasota, Florida 34230-3018
(941) 957-1900
mmayper@fergusonkipper.com
3392404.26517
May 23, 30, 2014 14-02329S

FIRST INSERTION

NOTICE TO CREDITORS IN THE CIRCUIT COURT FOR SARASOTA COUNTY, FLORIDA PROBATE DIVISION
File No. 2014 CP 1019 NC
Division Probate
IN RE: ESTATE OF CAROL M. SKUTNIK,
Deceased.

The administration of the estate of Carol M. Skutnik, deceased, whose date of death was February 2, 2014, is pending in the Circuit Court for Sarasota County, Florida, Probate Division, the address of which is P.O. Box 3079, Sarasota, Florida 34230-3079. The names and addresses of the personal representative and the personal representative's attorney are set forth below.

All creditors of the decedent and other persons having claims or demands against decedent's estate on whom a copy of this notice is required to be served must file their claims with this court WITHIN THE LATER OF 3 MONTHS AFTER THE TIME OF THE FIRST PUBLICATION OF THIS NOTICE OR 30 DAYS AFTER THE DATE OF SERVICE OF A COPY OF THIS NOTICE ON THEM.

All other creditors of the decedent and other persons having claims or demands against decedent's estate must file their claims with this court WITHIN 3 MONTHS AFTER THE DATE OF THE FIRST PUBLICATION OF THIS NOTICE.

ALL CLAIMS NOT FILED WITHIN THE TIME PERIODS SET FORTH IN SECTION 733.702 OF THE FLORIDA PROBATE CODE WILL BE FOREVER BARRED.

NOTWITHSTANDING THE TIME PERIODS SET FORTH ABOVE, ANY CLAIM FILED TWO (2) YEARS OR MORE AFTER THE DECEDENT'S DATE OF DEATH IS BARRED.

The date of first publication of this notice is May 23, 2014.

Personal Representative:
Joseph H. Skutnik
34 Quirico Drive
Pittsfield, Massachusetts 01201
Attorney for Personal Representative:
Bradley D. Magee, Esq.
Attorney for Joseph H. Skutnik
Florida Bar No. 861730
BRADLEY D. MAGEE, ATTORNEY AT LAW, P.L.
P.O. Box 3
Osprey, FL 34229
Telephone: (941) 918-9894
Email: magee-law@comcast.net
May 23, 30, 2014 14-02266S

FIRST INSERTION

Notice Under Fictitious Name Law Pursuant to Section 865.09, Florida Statutes

NOTICE IS HEREBY GIVEN that the undersigned, desiring to engage in business under the fictitious name of Navamaze located at 413 Valencia Road, in the County of Sarasota, in the City of Venice, Florida 34285 intends to register the said name with the Division of Corporations of the Florida Department of State, Tallahassee, Florida.

Dated at Venice, Florida, this 14th day of May, 2014.

SENIOR LIVING SOLUTIONS OF VENICE LLC
May 23, 2014 14-02251S

FIRST INSERTION

Notice Under Fictitious Name Law Pursuant to Section 865.09, Florida Statutes

NOTICE IS HEREBY GIVEN that the undersigned, desiring to engage in business under the fictitious name of Berry Reliable Bookkeeping located at 5577 Colonial Oaks Blvd., in the County of Sarasota in the City of Sarasota, Florida 34232 intends to register the said name with the Division of Corporations of the Florida Department of State, Tallahassee, Florida.

Dated at Sarasota, Florida, this 15 day of May, 2014.

Tammy L. Berry
May 23, 2014 14-02250S

FIRST INERTION

RE-NOTICE OF FORECLOSURE SALE IN THE CIRCUIT COURT OF THE 12TH JUDICIAL CIRCUIT, IN AND FOR SARASOTA COUNTY, FLORIDA
CIVIL DIVISION:
CASE NO.: 2008 CA 002561 NC
AURORA LOAN SERVICES, LLC,
Plaintiff, vs.
JOSEPH GARY RUBY;
MORTGAGE ELECTRONIC REGISTRATION SYSTEMS INCORPORATED AS A NOMINEE FOR CENTURY BANK, F.S.B.;
KRISTEN ROCKS; UNKNOWN SPOUSE OF KRISTEN ROCKS;
JOHN DOE; JANE DOE AS UNKNOWN TENANT(S) IN POSSESSION OF THE SUBJECT PROPERTY,
Defendants.

NOTICE IS HEREBY GIVEN pursuant to an Order Resetting Foreclosure Sale dated the 8th day of May, 2014, and entered in Case No. 2008 CA 002561 NC, of the Circuit Court of the 12TH Judicial Circuit in and for Sarasota County, Florida, wherein AURORA LOAN SERVICES, LLC is the Plaintiff and JOSEPH GARY RUBY; MORTGAGE ELECTRONIC REGISTRATION SYSTEMS INCORPORATED AS A NOMINEE FOR CENTURY BANK, F.S.B.; KRISTEN ROCKS; UNKNOWN SPOUSE OF KRISTEN ROCKS; JOHN DOE and UNKNOWN TENANT(S) IN POSSESSION OF THE SUBJECT PROPERTY are defendants. The Clerk of this Court shall sell to the highest and best bidder for cash electronically at www.sarasota.realforeclose.com, at 9:00 AM on the 12th day of June, 2014, the following described property as set forth in said Final Judgment, to wit:

SEE EXHIBIT "A" ATTACHED BEGIN AT THE MOST NORTHERLY CORNER OF LOT 23, BLOCK F, LIDO C, AS PER PLAT THEREOF RECORDED IN PLAT BOOK 5, PAGES 3 AND 3A, OF THE PUBLIC RECORDS OF SARASOTA COUNTY, FLORIDA; THENCE S.9°47'W ALONG THE EASTERLY LINE OF SAID LOT, 190.3 FEET TO THE SOUTH-EASTERLY CORNER OF SAID LOT; THENCE SOUTHERLY ALONG THE EASTERLY LINE OF LOT 22, ALONG A CURVE TO THE RIGHT WITH A RADIUS OF 249.37 FEET ALONG

A CHORD WHICH BEARS S.12°39'W, A DISTANCE OF 25 FEET; THENCE N. 68°26'W, 113.29 FEET MORE OR LESS, TO A POINT ON THE WESTERLY LINE OF LOT 23, SAID POINT BEING LOCATED 26.5 FEET NORTHERLY FROM THE SOUTHWESTERLY CORNER OF SAID LOT 23; THENCE NORTHERLY ALONG SAID WESTERLY LINE OF LOT 23, ALONG A CURVE TO THE RIGHT WITH A RADIUS OF 237.94 FEET, THE CHORD OF WHICH BEARS N. 33°53'E, A DISTANCE OF 85.9 FEET TO THE END OF SAID CURVE; THENCE CONTINUE N. 44°18'E, ALONG SAID LOT LINE, A DISTANCE OF 137.2 FEET TO THE POINT OF BEGINNING; BEING A PART OF LOTS 22 AND 23 BLOCK F, OF SAID LIDO C, ALL LYING, BEING AND SITUATE IN THE COUNTY OF SARASOTA, STATE OF FLORIDA.

ANY PERSON CLAIMING AN INTEREST IN THE SURPLUS FROM THE SALE, IF ANY, OTHER THAN THE PROPERTY OWNER AS OF THE DATE OF THE LIS PENDENS MUST FILE A CLAIM WITHIN 60 DAYS AFTER THE SALE.
If you are a person with a disability who needs any accommodation in order to participate in this proceeding, you are entitled, at no cost to you, to the provision of certain assistance. Please contact the Sarasota County Jury Office, P.O. Box 3079, Sarasota, Florida 34230-3079, (941)861-7400, at least seven (7) days before your scheduled court appearance, or immediately upon receiving this notification if the time before the scheduled appearance is less than seven (7) days; if you are hearing or voice impaired, call 711.
Dated this 16 day of May, 2014.
By: Jennifer Nicole Tarquinio
Bar #99192
Choice Legal Group, P.A.
P.O. Box 9908
Fort Lauderdale, FL 33310-0908
Telephone: (954) 453-0365
Facsimile: (954) 771-6052
Toll Free: 1-800-441-2438
DESIGNATED PRIMARY E-MAIL FOR SERVICE PURSUANT TO FLA R. JUD. ADMIN 2.516
eservice@clelegalgroup.com
08-06022
May 23, 30, 2014 14-02292S

FIRST INSERTION

NOTICE OF SALE IN THE CIRCUIT COURT OF THE TWELFTH JUDICIAL CIRCUIT IN AND FOR SARASOTA COUNTY, FLORIDA

Case No. 2009 CA 016885 NC
DEUTSCHE BANK NATIONAL TRUST COMPANY, AS TRUSTEE OF THE INDYMAC INDX MORTGAGE TRUST, et al
Plaintiff, vs.
SHERRY STONEBAKER, et al
Defendants.

NOTICE IS HEREBY GIVEN pursuant to a Final Judgment of Foreclosure entered in the above-styled case, Case No. 2009 CA 016885 NC, in the Circuit Court in and for Sarasota County, Florida, that I will sell to the highest and best bidder for cash online at www.sarasota.realforeclose.com at 9:00 a.m., on the 16th day of June, 2014, the following described property:

Lot 65, Palmer Glen, Phase I, as per plat thereof recorded in Plat Book 40, Pages 44, 44A through 44G of the Public Records of Sarasota County, Florida.

If you are a person with a disability who needs any accommodation in order to participate in this proceeding, you are entitled, at no cost to you, to the provision of certain assistance. Please contact the Sarasota County Jury Office, P.O. Box 3079, Sarasota, Florida 34230-3079, (941)861-7400, at least seven (7) days before your scheduled court appearance, or immediately upon receiving this notification if the time before the scheduled appearance is less than seven (7) days; if you are hearing or voice impaired, call 711.

Dated this 16 day of May, 2014.
By: /s/ Sharon S. Vander Wulp
SHARON S. VANDER WULP, P.A.
ESQUIRE
712 Shamrock Boulevard
Venice, FL 34293
(941) 492-2100 phone
(941) 492-3116 fax
Florida Bar No. 618608
Counsel for Plaintiff
Primary: office@svwpa.com
Secondary: arman@svwpa.com
May 23, 30, 2014 14-02257S

FIRST INSERTION

NOTICE OF FORECLOSURE SALE IN THE CIRCUIT COURT OF THE TWELFTH JUDICIAL CIRCUIT IN AND FOR SARASOTA COUNTY, FLORIDA GENERAL JURISDICTION DIVISION

CASE NO. 2012 CA 005306 NC OCWEN LOAN SERVICING, LLC, Plaintiff, vs. STUART W. FELDMANN, et al., Defendants.

NOTICE IS HEREBY GIVEN pursuant to a Summary Final Judgment of Foreclosure entered March 24, 2014 in Civil Case No. 2012 CA 005306 NC of the Circuit Court of the TWELFTH Judicial Circuit in and for Sarasota County, Florida, wherein OCWEN LOAN SERVICING, LLC is Plaintiff and STUART W. FELDMANN, TENBUSCH CONSTRUCTION, INC., UNKNOWN TENANT IN POSSESSION #1 N/K/A ANTHONY LEMOS, UNKNOWN TENANT IN POSSESSION #2, UNKNOWN SPOUSE OF STUART W. FELDMANN, are Defendants, the Clerk of Court will sell to the highest and best bidder for cash electronically at www.sarasota.realforeclose.com in accordance with Chapter 45, Florida Statutes on the 12th day of June, 2014 at 09:00 AM on the following described property as set forth in said Summary Final Judgment, to-wit:

Lot 5, Block 1198, 35TH ADDITION TO PORT CHARLOTTE SUBDIVISION, according to the plat thereof recorded in Plat Book 15, Pages 19A through 19C, Inclusive, Public Records of Sarasota County, Florida.

Any person claiming an interest in the surplus from the sale, if any, other than the property owner as of the date of the lis pendens, must file a claim within 60 days after the sale.

If you are a person with a disability who needs any accommodation in order to participate in this proceeding, you are entitled, at no cost to you, to the provision of certain assistance. Please contact the Sarasota County Jury Office, P.O. Box 3079, Sarasota, Florida 34230-3079, (941)861-7400, at least seven (7) days before your scheduled court appearance, or immediately upon receiving this notification if the time before the scheduled appearance is less than seven (7) days; if you are hearing or voice impaired, call 711.

Allyson G Morgado
FL Bar # 91506
Brian Hummel, Esq.
Fla. Bar No.: 46162

McCalla Raymer, LLC
Attorney for Plaintiff
225 E. Robinson St. Suite 660
Orlando, FL 32801
Phone: (407) 674-1850
Fax: (321) 248-0420
Email:
MRService@mcallarayermer.com
2839770
11-05630-5
May 23, 30, 2014 14-02254S

FIRST INSERTION

NOTICE OF FORECLOSURE SALE IN THE CIRCUIT COURT OF THE TWELFTH JUDICIAL CIRCUIT IN AND FOR SARASOTA COUNTY, FLORIDA CIVIL ACTION

CASE NO.: 58-2013-CA-008221 NC DIVISION: C U.S. BANK NATIONAL ASSOCIATION, AS TRUSTEE, FOR AMERICAN GENERAL MORTGAGE LOAN TRUST 2010-1 AMERICAN GENERAL MORTGAGE PASS-THROUGH CERTIFICATES, SERIES 2010-1, Plaintiff, vs. JOHN D. GILLES, et al, Defendant(s).

NOTICE IS HEREBY GIVEN pursuant to a Final Judgment of Mortgage Foreclosure dated May 12, 2014 and entered in Case No. 58-2013-CA-008221 NC of the Circuit Court of the TWELFTH Judicial Circuit in and for SARASOTA County, Florida wherein U.S. BANK NATIONAL ASSOCIATION, AS TRUSTEE, FOR AMERICAN GENERAL MORTGAGE LOAN TRUST 2010-1 AMERICAN GENERAL MORTGAGE PASS-THROUGH CERTIFICATES, SERIES 2010-1 is the Plaintiff and JOHN D. GILLES; TAMMY A. GILLES; are the Defendants. The Clerk will sell to the highest and best bidder for cash at WWW.SARASOTA.REALFORECLOSE.COM at 9:00AM, on the 9th day of September, 2014, the following described property as set forth in said Final Judgment:

LOT 115 OF TOWN & COUNTRY ESTATES, UNIT NO. 2, ACCORDING TO THE PLAT THEREOF AS RECORDED IN PLAT BOOK 10, PAGE 29, OF THE PUBLIC RECORDS OF SARASOTA COUNTY, FLORIDA.

A/K/A 3556 AUSTIN STREET, SARASOTA, FL 34231
Any person claiming an interest in the surplus from the sale, if any, other than the property owner as of the date of the Lis Pendens must file a claim within sixty (60) days after the sale.

If you are a person with a disability who needs any accommodation in order to participate in this proceeding, you are entitled, at no cost to you, to the provision of certain assistance. Please contact the Sarasota County Jury Office, P.O. Box 3079, Sarasota, Florida 34230-3079, (941)861-7400, at least seven (7) days before your scheduled court appearance, or immediately upon receiving this notification if the time before the scheduled appearance is less than seven (7) days; if you are hearing or voice impaired, call 711.

By: Lisa M. Lewis
Florida Bar No. 0086178
Ronald R Wolfe & Associates, P.L.
P.O. Box 25018
Tampa, Florida 33622-5018
(813) 251-4766
(813) 251-1541 Fax
F12019751
May 23, 30, 2014 14-02261S

FIRST INSERTION

NOTICE OF FORECLOSURE SALE IN THE CIRCUIT COURT OF THE 12TH JUDICIAL CIRCUIT, IN AND FOR SARASOTA COUNTY, FLORIDA CIVIL DIVISION:

CASE NO.: 2013 CA 001844 NC FEDERAL NATIONAL MORTGAGE ASSOCIATION, Plaintiff, vs. MICHAEL A. HITZMAN; SHARON C. HILBERS; CARL E. HILBERS, JR.; KATE F. HITZMAN; UNKNOWN TENANT IN POSSESSION OF THE SUBJECT PROPERTY, Defendants.

NOTICE IS HEREBY GIVEN pursuant to Final Judgment of Foreclosure dated the 5th day of May, 2014, and entered in Case No. 2013 CA 001844 NC, of the Circuit Court of the 12TH Judicial Circuit in and for Sarasota County, Florida, wherein FEDERAL NATIONAL MORTGAGE ASSOCIATION is the Plaintiff and SHARON C. HILBERS; CARL E. HILBERS, JR.; KATE F. HITZMAN and UNKNOWN TENANT (S) IN POSSESSION OF THE SUBJECT PROPERTY are defendants. The Clerk of this Court shall sell to the highest and best bidder for cash electronically at www.sarasota.realforeclose.com at 9:00 AM on the 6th day of June, 2014, the following described property as set forth in said Final Judgment, to-wit:

LOT 3, LAKEVIEW TERRACE, ACCORDING TO THE PLAT THEREOF, AS RECORDED IN PLAT BOOK 10, PAGE 30, OF THE PUBLIC RECORDS OF SARASOTA COUNTY, FLORIDA.

ANY PERSON CLAIMING AN INTEREST IN THE SURPLUS FROM THE SALE, IF ANY, OTHER THAN THE PROPERTY OWNER AS OF THE DATE OF THE LIS PENDENS MUST FILE A CLAIM WITHIN 60 DAYS AFTER THE SALE.

If you are a person with a disability who needs any accommodation in order to participate in this proceeding, you are entitled, at no cost to you, to the provision of certain assistance. Please contact the Sarasota County Jury Office, P.O. Box 3079, Sarasota, Florida 34230-3079, (941)861-7400, at least seven (7) days before your scheduled court appearance, or immediately upon receiving this notification if the time before the scheduled appearance is less than seven (7) days; if you are hearing or voice impaired, call 711.

Dated this 15th day of May, 2014.
By: Jennifer Nicole Tarquinio
Bar #99192

Choice Legal Group, P.A.
P.O. Box 9908
Fort Lauderdale, FL 33310-9908
Telephone: (954) 453-0365
Facsimile: (954) 771-6052
Toll Free: 1-800-441-2438
DESIGNATED PRIMARY E-MAIL FOR SERVICE PURSUANT TO FLA R. JUD. ADMIN 2.516
eservice@clegalgroup.com
11-15536
May 23, 30, 2014 14-02252S

FIRST INSERTION

NOTICE OF FORECLOSURE SALE IN THE CIRCUIT COURT OF THE 12TH JUDICIAL CIRCUIT, IN AND FOR SARASOTA COUNTY, FLORIDA

CASE NO. 2009 CA 020477 NC CIRCUIT CIVIL A U.S. BANK NATIONAL ASSOCIATION AS TRUSTEE, SUCCESSOR-IN-INTEREST TO WACHOVIA BANK, NATIONAL ASSOCIATION AS TRUSTEE FOR GSA HOME EQUITY Plaintiff, vs. MICHAEL T. BOWERMAN, SUSAN M. BOWERMAN, ET AL, Defendant(s).

NOTICE IS HEREBY GIVEN pursuant to a Final Judgment of Foreclosure dated MAY 8, 2014 and entered in Case No. 2009 CA 020477 NC of the Circuit Court of the Twelfth Judicial Circuit in and for Sarasota County, Florida wherein U.S. BANK NATIONAL ASSOCIATION AS TRUSTEE, SUCCESSOR-IN-INTEREST TO WACHOVIA BANK, NATIONAL ASSOCIATION AS TRUSTEE FOR GSA HOME EQUITY is the Plaintiff and, MICHAEL T. BOWERMAN and SUSAN M. BOWERMAN are the Defendant(s). The Clerk of the Circuit Court shall sell the property at public sale on June 23, 2014, to the highest bidder for cash, in accordance with section 45.031, Florida Statutes, by electronic sale beginning at 9:00 am, on the prescribed date at https://SARASOTA.REALFORECLOSE.COM the following described property as set forth in said Final Judgment to-wit:

LOT 80, SECLUDED OAKS, as per plat thereof recorded in plat Book 42, Page 25 of the Public Records of Sarasota County, Florida.
PARCEL ID # 00258-14-0015
ADDRESS: 6251 YELLOW WOOD PLACE, SARASOTA FL 34241

Any person claiming an interest in the surplus from the sale, if any, other than the property owner as of the date of the lis pendens must file a claim within 60 days after the sale.

If you are a person with a disability who needs any accommodation in order to participate in this proceeding, you are entitled, at no cost to you, to the provision of certain assistance. Please contact the Sarasota County Jury Office, P.O. Box 3079, Sarasota, Florida 34230-3079, (941)861-7400, at least seven (7) days before your scheduled court appearance, or immediately upon receiving this notification if the time before the scheduled appearance is less than seven (7) days; if you are hearing or voice impaired, call 711.

Dated this 15th day of MAY, 2014.
By: /S/Mark F. Booth
Mark F. Booth, Esq.
Fla. Bar No.: 829005

Attorney for Plaintiff:
ROGERS, MORRIS & ZIEGLER LLP
1401 East Broward Blvd., Suite 300
Ft. Lauderdale, FL 33301
Telephone: (954) 462-1431
Email: mfbooth@rmzlaw.com
Secondary Email: susan@rmzlaw.com
May 23, 30, 2014 14-02256S

FIRST INSERTION

NOTICE OF FORECLOSURE SALE IN THE CIRCUIT COURT OF THE TWELFTH JUDICIAL CIRCUIT, IN AND FOR SARASOTA COUNTY, FLORIDA

CASE NO. 2010 CA 012327 NC SUNTRUST MORTGAGE, INC, Plaintiff, vs. ELLEN S. GOLDBERG, et al, Defendants

NOTICE IS HEREBY GIVEN pursuant to a Final Judgment of Foreclosure dated March 17, 2014, and entered in Case No. 2010 CA 012327 NC, of the Circuit Court of the Twelfth Judicial Circuit in and for SARASOTA County, Florida. U.S. BANK TRUST, N.A., AS TRUSTEE FOR VOLT NPL IX ASSET HOLDINGS TRUST, is Plaintiff and ELLEN S. GOLDBERG; SUNTRUST BANK; ELLEN S. GOLDBERG, AS TRUSTEE OF THE MARK L. TISHMAN REVOCABLE LIVING TRUST DATED 11/7/1996; SHIRLEY J. GOLDBERG TRUSTEE OF THE SHIRLEY J. GOLDBERG LIVING TRUST DATED 11/7/1996; MARK L. TISHMAN; MARK L. TISHMAN, AS TRUSTEE OF THE MARK L. TISHMAN REVOCABLE LIVING TRUST DATED 11/7/1996; UNKNOWN HEIRS, BENEFICIARIES, DEVISEES, ASSIGNEES, LIENORS, CREDITORS, TRUSTEES AND ALL OTHERS WHO MAY CLAIM AN INTEREST IN THE MARK L. TISHMAN REVOCABLE LIVING TRUST DATED 11/7/1996, are defendants. The Clerk of Court will sell to the highest and best bidder for cash via the Internet at www.sarasota.realforeclose.com, at 9:00 a.m., on the 13th day of June, 2014, the following described property as set forth in said Final Judgment, to-wit:

LOT 13, KENTWOOD ESTATES AS PER PLAT THEREOF RECORDED IN PLAT BOOK 18, PAGE 32 OF THE PUBLIC RECORDS OF SARASOTA COUNTY, FLORIDA

Any person claiming an interest in the surplus from the sale, if any, other than the property owner as of the date of the Lis Pendens must file a claim within 60 days after the sale.

If you are a person with a disability who needs any accommodation in order to participate in this proceeding, you are entitled, at no cost to you, to the provision of certain assistance. Please contact the Sarasota County Jury Office, P.O. Box 3079, Sarasota, Florida 34230-3079, (941)861-7400, at least seven (7) days before your scheduled court appearance, or immediately upon receiving this notification if the time before the scheduled appearance is less than seven (7) days; if you are hearing or voice impaired, call 711.

Mark C. Elia, Esq.
Florida Bar #: 695734
Email: MCElia@vanlawfl.com
VAN NESS LAW FIRM, PLC
1239 E. Newport Center Drive,
Suite 110
Deerfield Beach, Florida 33442
Ph: (954) 571-2031
Fax: (954) 571-2033
PRIMARY EMAIL:
Pleadings@vanlawfl.com
VF7327-12/ee
May 23, 30, 2014 14-02238S

FIRST INSERTION

NOTICE OF FORECLOSURE SALE IN THE CIRCUIT COURT OF THE TWELFTH JUDICIAL CIRCUIT IN AND FOR SARASOTA COUNTY, FLORIDA CIVIL ACTION

CASE NO.: 58-2013-CA-008132 NC DIVISION: A NORTHERN TRUST, N.A., Plaintiff, vs. GARY E. PROBST A/K/A GARY PROBST, et al, Defendant(s).

NOTICE IS HEREBY GIVEN pursuant to a Final Judgment of Mortgage Foreclosure dated May 12, 2014 and entered in Case No. 58-2013-CA-008132 NC of the Circuit Court of the TWELFTH Judicial Circuit in and for SARASOTA County, Florida wherein NORTHERN TRUST, N.A. is the Plaintiff and GARY E. PROBST A/K/A GARY PROBST; THE UNKNOWN SPOUSE OF GARY E. PROBST A/K/A GARY PROBST; ANY AND ALL UNKNOWN PARTIES CLAIMING BY, THROUGH, UNDER, AND AGAINST THE HEREIN NAMED INDIVIDUAL DEFENDANT(S) WHO ARE NOT KNOWN TO BE DEAD OR ALIVE, WHETHER SAID UNKNOWN PARTIES MAY CLAIM AN INTEREST AS SPOUSES, HEIRS, DEVISEES, GRANTEEES, OR OTHER CLAIMANTS; TENANT #1 N/K/A TIFFANY HARRIS, and TENANT #2 N/K/A TOM HARRIS are the Defendants. The Clerk will sell to the highest and best bidder for cash at WWW.SARASOTA.REALFORECLOSE.COM at 9:00AM, on the 18th day of June, 2014, the following described property as set forth in said Final Judgment:

LOT 19, CHANNEL ACRES, ACCORDING TO THE PLAT THEREOF RECORDED IN PLAT BOOK 10, PAGE 51, OF THE PUBLIC RECORDS OF SARASOTA A COUNTY, FLORIDA.

SUBJECT TO RESTRICTIONS, RESERVATIONS AND EASEMENTS OF RECORD, IF ANY.

Any person claiming an interest in the surplus from the sale, if any, other than the property owner as of the date of the Lis Pendens must file a claim within sixty (60) days after the sale.

If you are a person with a disability who needs any accommodation in order to participate in this proceeding, you are entitled, at no cost to you, to the provision of certain assistance. Please contact the Sarasota County Jury Office, P.O. Box 3079, Sarasota, Florida 34230-3079, (941)861-7400, at least seven (7) days before your scheduled court appearance, or immediately upon receiving this notification if the time before the scheduled appearance is less than seven (7) days; if you are hearing or voice impaired, call 711.

By: Victoria S. Jones
Florida Bar No. 52252
Ronald R Wolfe & Associates, P.L.
P.O. Box 25018
Tampa, Florida 33622-5018
(813) 251-4766
(813) 251-1541 Fax
F13015133
May 23, 30, 2014 14-02242S

FIRST INERTION

NOTICE OF FORECLOSURE SALE IN THE CIRCUIT COURT OF THE TWELFTH JUDICIAL CIRCUIT IN AND FOR SARASOTA COUNTY, FLORIDA CIVIL ACTION

CASE NO.: 58 2013 CA 004894 NC DIVISION: A JAMES B. NUTTER & COMPANY, Plaintiff, vs. THE UNKNOWN HEIRS, DEVISEES, GRANTEEES, ASSIGNEES, LIENORS, CREDITORS, TRUSTEES, OR OTHER CLAIMANTS CLAIMING BY, THROUGH, UNDER, OR AGAINST RICHARD A. WINTER A/K/A RICHARD ALAN WINTER, DECEASED, et al, Defendant(s).

NOTICE IS HEREBY GIVEN pursuant to a Final Judgment of Mortgage Foreclosure dated May 12, 2014 and entered in Case No. 58 2013 CA 004894 NC of the Circuit Court of the TWELFTH Judicial Circuit in and for SARASOTA County, Florida wherein JAMES B. NUTTER & COMPANY is the Plaintiff and THE UNKNOWN HEIRS, DEVISEES, GRANTEEES, ASSIGNEES, LIENORS, CREDITORS, TRUSTEES, OR OTHER CLAIMANTS CLAIMING BY, THROUGH, UNDER, OR AGAINST RICHARD A. WINTER A/K/A RICHARD ALAN WINTER, DECEASED; DAVID E. DESROCHES, AS AN HEIR OF THE ESTATE OF RICHARD A. WINTER A/K/A RICHARD ALAN WINTER, DECEASED; MARY JOSSELYN WINTER A/K/A MARY J. WINTER, AS AN HEIR OF THE ESTATE OF RICHARD A. WINTER A/K/A RICHARD ALAN WINTER, DECEASED; DEBRA A. GRAHAM A/K/A DEBORAH ANN GRAHAM F/K/A DEBORAH ANN WINTER, AS AN HEIR OF THE ESTATE OF RICHARD A. WINTER A/K/A RICHARD ALAN WINTER, DECEASED; ANY AND ALL UNKNOWN PARTIES CLAIMING BY, THROUGH, UNDER, AND AGAINST THE HEREIN NAMED INDIVIDUAL DEFENDANT(S) WHO ARE NOT KNOWN TO BE

DEAD OR ALIVE, WHETHER SAID UNKNOWN PARTIES MAY CLAIM AN INTEREST AS SPOUSES, HEIRS, DEVISEES, GRANTEEES, OR OTHER CLAIMANTS; UNITED STATES OF AMERICA ON BEHALF OF U.S. DEPARTMENT OF HOUSING AND URBAN DEVELOPMENT; are the Defendants. The Clerk will sell to the highest and best bidder for cash at WWW.SARASOTA.REALFORECLOSE.COM at 9:00AM, on the 16th day of June, 2014, the following described property as set forth in said Final Judgment:

LOT 9, BLOCK 18, 13TH ADDITION TO PORT CHARLOTTE SUBDIVISION, ACCORDING TO THE PLAT RECORDED IN PLAT BOOK 13, PAGES 12, 12A THROUGH 12F, OF THE PUBLIC RECORDS OF SARASOTA COUNTY, FLORIDA.

A/K/A 6408 PAN AMERICAN BOULEVARD, NORTH PORT, FL 34287
Any person claiming an interest in the surplus from the sale, if any, other than the property owner as of the date of the Lis Pendens must file a claim within sixty (60) days after the sale.

If you are a person with a disability who needs any accommodation in order to participate in this proceeding, you are entitled, at no cost to you, to the provision of certain assistance. Please contact the Sarasota County Jury Office, P.O. Box 3079, Sarasota, Florida 34230-3079, (941)861-7400, at least seven (7) days before your scheduled court appearance, or immediately upon receiving this notification if the time before the scheduled appearance is less than seven (7) days; if you are hearing or voice impaired, call 711.

By: J. Bennett Kitterman
Florida Bar No. 98636
Ronald R Wolfe & Associates, P.L.
P.O. Box 25018
Tampa, Florida 33622-5018
(813) 251-4766
(813) 251-1541 Fax
F13006929
May 23, 30, 2014 14-02259S

FIRST INERTION

NOTICE OF RESCHEDULED FORECLOSURE SALE IN THE CIRCUIT COURT OF THE TWELFTH JUDICIAL CIRCUIT IN AND FOR SARASOTA COUNTY, FLORIDA CIVIL ACTION

CASE NO.: 2009-CA-009236-NC DIVISION: A WELLS FARGO BANK, NATIONAL ASSOCIATION AS TRUSTEE FOR THE CERTIFICATEHOLDERS OF STRUCTURED ASSET MORTGAGE INVESTMENTS II INC., GREENPOINT MTA TRUST 2006-AR3, MORTGAGE PASS-THROUGH CERTIFICATES, SERIES 2006-AR3, Plaintiff, vs. ANTHONY D'ATRIA, et al, Defendant(s).

NOTICE IS HEREBY GIVEN pursuant to an Order Rescheduling Foreclosure Sale dated May 5, 2014 and entered in Case NO. 2009-CA-009236-NC of the Circuit Court of the TWELFTH Judicial Circuit in and for SARASOTA County, Florida wherein WELLS FARGO BANK, NATIONAL ASSOCIATION AS TRUSTEE FOR THE CERTIFICATEHOLDERS OF STRUCTURED ASSET MORTGAGE INVESTMENTS II INC., GREENPOINT MTA TRUST 2006-AR3, MORTGAGE PASS-THROUGH CERTIFICATES, SERIES 2006-AR3, is the Plaintiff and ANTHONY D'ATRIA; MORTGAGE ELECTRONIC REGISTRATION SYSTEMS INCORPORATED AS NOMINEE FOR BAC HOME LOANS SERVICING, LP; RENAISSANCE I ASSOCIATION, INC.; ROSEMARY PLACE MASTER ASSOCIATION, INC. F/K/A THE RENAISSANCE OF SARASOTA MASTER ASSOCIATION, INC.; TENANT #1 N/K/A MICHAEL HUGEN are the Defendants. The Clerk will sell to the highest and best bidder for cash at WWW.SARASOTA.REALFORECLOSE.COM at 9:00AM, on 06/18/2014, the following described property as set forth in said Final Judgment:

UNIT NO. 1402, RENAISSANCE I, A CONDOMINIUM ACCORDING TO THE DECLARATION OF CONDOMINIUM RECORDED IN OFFICIAL RECORDS INSTRUMENT NO. 2001000167 AND AMENDMENTS THERETO, AND AS PER PLAT THEREOF RECORDED IN CONDOMINIUM BOOK 34, PAGES 39 THRU 39HH, AND AMENDMENTS THERETO, OF THE PUBLIC RECORDS OF SARASOTA COUNTY, FLORIDA TOGETHER WITH AN UNDIVIDED INTEREST IN THE COMMON ELEMENTS APPURTENANT THERETO AS SET FORTH IN SAID DECLARATION

A/K/A 750 N TAMIAMI TRAILUNIT 1402, SARASOTA, FL 34236
Any person claiming an interest in the surplus from the sale, if any, other than the property owner as of the date of the Lis Pendens must file a claim within sixty (60) days after the sale.
If you are a person with a disability who needs any accommodation in order to participate in this proceeding, you are entitled, at no cost to you, to the provision of certain assistance. Please contact the Sarasota County Jury Office, P.O. Box 3079, Sarasota, Florida 34230-3079, (941)861-7400, at least seven (7) days before your scheduled court appearance, or immediately upon receiving this notification if the time before the scheduled appearance is less than seven (7) days; if you are hearing or voice impaired, call 711.
By: Victoria S. Jones
Florida Bar No. 52252
Ronald R Wolfe & Associates, P.L.
P.O. Box 25018
Tampa, Florida 33622-5018
(813) 251-4766
(813) 251-1541 Fax
F09058757
May 23, 30, 2014 14-02264S

FIRST INERTION

NOTICE OF FORECLOSURE SALE IN THE CIRCUIT COURT OF THE TWELFTH JUDICIAL CIRCUIT IN AND FOR SARASOTA COUNTY, FLORIDA CIVIL ACTION

CASE NO.: 2010-CA-007890-NC DIVISION: A BAC HOME LOANS SERVICING, LP FKA COUNTRYWIDE HOME LOANS SERVICING LP, Plaintiff, vs. JACINDA J. GUNDZIK A/K/A JACINDA GUNDZIK, et al, Defendant(s).

NOTICE IS HEREBY GIVEN pursuant to a Final Judgment of Mortgage Foreclosure dated May 12, 2014 and entered in Case No. 2010-CA-007890-NC of the Circuit Court of the TWELFTH Judicial Circuit in and for SARASOTA County, Florida wherein GREEN TREE SERVICING LLC, 1 Plaintiff name has changed pursuant to order previously entered, is the Plaintiff and JACINDA J. GUNDZIK A/K/A JACINDA GUNDZIK; DARYLL GUNDZIK; ANY AND ALL UNKNOWN PARTIES CLAIMING BY, THROUGH, UNDER, AND AGAINST THE HEREIN NAMED INDIVIDUAL DEFENDANT(S) WHO ARE NOT KNOWN TO BE DEAD OR ALIVE, WHETHER SAID UNKNOWN PARTIES MAY CLAIM AN INTEREST AS SPOUSE, HEIRS, DEVISEES, GRANTEEES, OR OTHER CLAIMANTS; CITIBANK, NATIONAL ASSOCIATION SUCCESSOR BY MERGER TO CITIBANK, FSB; are the Defendants. The Clerk will sell to the highest and best bidder for cash at WWW.SARASOTA.REALFORECLOSE.COM at 9:00AM, on the 17th day of June, 2014, the following described property as set forth in said Final Judgment:

LOT 38, BLOCK 2581, FIFTY-FIRST ADDITION TO PORT CHARLOTTE SUBDIVISION, A SUBDIVISION ACCORDING TO THE PLAT THEREOF AS RECORDED IN PLAT BOOK 21, PAGE 8, SA THROUGH 8GG, OF THE PUBLIC RECORDS OF SARASOTA COUNTY, FLORIDA.
A/K/A 2042 LOVOY COURT, NORTH PORT, FL 34288
Any person claiming an interest in the surplus from the sale, if any, other than the property owner as of the date of the Lis Pendens must file a claim within sixty (60) days after the sale.
If you are a person with a disability who needs any accommodation in order to participate in this proceeding, you are entitled, at no cost to you, to the provision of certain assistance. Please contact the Sarasota County Jury Office, P.O. Box 3079, Sarasota, Florida 34230-3079, (941)861-7400, at least seven (7) days before your scheduled court appearance, or immediately upon receiving this notification if the time before the scheduled appearance is less than seven (7) days; if you are hearing or voice impaired, call 711.
By: J. Bennett Kitterman
Florida Bar No. 98636
Ronald R Wolfe & Associates, P.L.
P.O. Box 25018
Tampa, Florida 33622-5018
(813) 251-4766
(813) 251-1541 Fax
F10044074
May 23, 30, 2014 14-02258S

HOW TO PUBLISH YOUR LEGAL NOTICE IN THE **Business Observer**

FOR MORE INFORMATION, CALL:
(813) 221-9505 Hillsborough, Pasco
(727) 447-7784 Pinellas
(941) 906-9386 Manatee, Sarasota, Lee
(239) 263-0122 Collier
(407) 654-5500 Orange
(941) 248-4000 Charlotte
Or e-mail: legal@businessobserverfl.com

FIRST INSERTION

NOTICE OF ACTION-
CONSTRUCTIVE SERVICE
IN THE CIRCUIT COURT OF THE
TWELFTH JUDICIAL CIRCUIT
IN AND FOR SARASOTA COUNTY,
FLORIDA
GENERAL JURISDICTION
DIVISION

Case No. 2013 CA 000372 NC
Central Mortgage Company
Plaintiff,

vs.
Gyula Tamas Novak; et al.,
Defendants.

TO: Gyula Tamas Novak
Last Known Address: 360 Drake Road,
Venice, FL 34293
Unknown Spouse of Gyula Tamas Novak
Last Known Address: 360 Drake Road,
Venice, FL 34293

YOU ARE HEREBY NOTIFIED
that an action to foreclose a mortgage
on the following property in Sarasota
County, Florida:

CONDOMINIUM UNIT 7-304,
LAS PALMAS OF SARASOTA,
A LUXURY CONDOMINIUM,
TOGETHER WITH AN UN-
DIVIDED INTEREST IN THE
COMMON ELEMENTS, AC-
CORDING TO THE DECLAR-
ATION OF CONDOMINIUM
THEREOF RECORDED IN IN-
STRUMENT #2004247846, AS
AMENDED IN INSTRUMENT
#2004247847, OF THE PUB-
LIC RECORDS OF SARASOTA
COUNTY, FLORIDA.

has been filed against you and you are
required to serve a copy of your written
defenses, if any, to it on Jeremy Apis-
dorf, Esquire, Brock & Scott, PLLC,
the Plaintiff's attorney, whose address
is 1501 N.W. 49th Street, Suite 200, Ft.
Lauderdale, FL 33309, on or before
June 23, 2014, and file the original with
the Clerk of this Court either before ser-
vice on the Plaintiff's attorney or imme-
diately thereafter; otherwise a default
will be entered against you for the relief
demanded in the complaint or petition.

If you are a person with a disability
who needs any accommodation in order
to participate in this proceeding, you are
entitled, at no cost to you, to the
provision of certain assistance. Please
contact the Sarasota County Jury Of-
fice, P.O. Box 3079, Sarasota, Florida
34230-3079, (941)861-7400, at least
seven (7) days before your scheduled
court appearance, or immediately upon
receiving this notification if the time
before the scheduled appearance is less
than seven (7) days; if you are hearing
or voice impaired, call 711.

DATED on May 8, 2014.
Karen Rushing
As Clerk of the Court
(SEAL) By C. Brandenburg
As Deputy Clerk

Jeremy Apisdorf, Esquire
Brock & Scott, PLLC
the Plaintiff's Attorney
1501 N.W. 49th St., Suite 200
Ft. Lauderdale, FL 33309
File # 13-F02504
May 23, 30, 2014 14-02225S

FIRST INSERTION

NOTICE OF SALE
IN THE CIRCUIT COURT OF THE
TWELFTH JUDICIAL CIRCUIT
IN AND FOR SARASOTA COUNTY,
FLORIDA
CIVIL DIVISION
Case #: 2009-CA-021628-NC
DIVISION: C

Nationstar Mortgage LLC
Plaintiff, -vs.-
Mark E. Fanning a/k/a Mark
Fanning and Becky D. Fanning,
Husband and Wife; Chase Bank
USA, N.A.; Mortgage Electronic
Registration Systems, Inc. as
Nominee for Irwin Mortgage
Corporation Electronic Data
Systems, LLC
Defendant(s).

NOTICE IS HEREBY GIVEN pursu-
ant to order rescheduling foreclosure
sale or Final Judgment, entered in Civil
Case No. 2009-CA-021628-NC of the
Circuit Court of the 12th Judicial Cir-
cuit in and for Sarasota County, Flori-
da, wherein Nationstar Mortgage LLC,
Plaintiff and Mark E. Fanning a/k/a
Mark Fanning and Becky D. Fanning,
Husband and Wife are defendant(s), I,
Clerk of Court, Karen E. Rushing, will
sell to the highest and best bidder for
cash VIA THE INTERNET AT WWW.
SARASOTA.REALFORECLOSE.COM,
AT 9:00 A.M. on June 18, 2014,
the following described property as set
forth in said Final Judgment, to-wit:

LOT 25, BLOCK 459, 9TH
ADDITION TO PORT CHAR-
LOTTE SUBDIVISION, AC-
CORDING TO THE PLAT
THEREOF, AS RECORDED IN
PLAT BOOK 12, PAGES 21, 21A
THROUGH 21S, PUBLIC RE-
CORDS OF SARASOTA COUN-
TY, FLORIDA.

ANY PERSON CLAIMING AN IN-
TEREST IN THE SURPLUS FROM
THE SALE, IF ANY, OTHER THAN
THE PROPERTY OWNER AS OF
THE DATE OF THE LIS PENDENS
MUST FILE A CLAIM WITHIN 60
DAYS AFTER THE SALE.

If you are a person with a disability
who needs any accommodation in order
to participate in this proceeding, you
are entitled, at no cost to you, to the
provision of certain assistance. Please
contact the Sarasota County Jury Of-
fice, P.O. Box 3079, Sarasota, Florida
34230-3079, (941)861-7400,
at least seven (7) days before your
scheduled court appearance, or imme-
diately upon receiving this notification
if the time before the scheduled ap-
pearance is less than seven (7) days;
if you are hearing or voice impaired,
call 711.

Dated on May 14th, 2014.
KAREN E. RUSHING
As Clerk of the Court
(SEAL) By: L. Szymanski
As Deputy Clerk
Submitted By:
ATTORNEY FOR PLAINTIFF:
SHAPIRO, FISHMAN
& GACHÉ, LLP
2424 North Federal Highway,
Suite 360
Boca Raton, Florida 33431
(561) 998-6700
(561) 998-6707
09-161323 FC01 CXE
May 23, 30, 2014 14-02235S

FIRST INSERTION

NOTICE OF ACTION
IN THE CIRCUIT COURT OF THE
TWELFTH JUDICIAL CIRCUIT
IN AND FOR SARASOTA COUNTY,
FLORIDA

CASE NO.: 2012 CA 003509 NC
WELLS FARGO BANK, NA,
Plaintiff, VS.

UNKNOWN HEIRS,
BENEFICIARIES, DEVISEES,
GRANTEES, ASSIGNEES,
LIENORS; et al.,
Defendant(s).

TO: Unknown Heirs, Beneficiaries,
Devisees, Grantees, Assignees, Lienors,
Creditors, Trustees, and all other par-
ties claiming an interest By, Through,
Under or Against The Estate of Carol
S. Wolfson A/K/A Carol S. Lampman,
Deceased
Last Known Residence: Unknown

YOU ARE HEREBY NOTIFIED
that an action to foreclose a mortgage
on the following property in SARASO-
TA County, Florida:

LOT 9, LOMA LINDA PARK,
A SUBDIVISION AS PER
PLAT THEREOF RECORDED
IN PLAT BOOK 5, PAGE 38
OF THE PUBLIC RECORDS
OF SARASOTA COUNTY,
FLORIDA.

has been filed against you and you are
required to serve a copy of your written
defenses, if any, to it on ALDRIDGE |
CONNORS, LLP, Plaintiff's attorney,
at 1615 South Congress Avenue, Suite
200, Delray Beach, FL 33445 (Phone
Number: (561) 392-6391), within 30
days of the first date of publication of
this notice, and file the original with
the clerk of this court either before
June 23rd, 2014 on Plaintiff's attorney
or immediately thereafter; otherwise a
default will be entered against you for
the relief demanded in the complaint
or petition.

If you are a person with a disability
who needs any accommodation in order
to participate in this proceeding, you
are entitled, at no cost to you, to the
provision of certain assistance. Please
contact the Sarasota County Jury Of-
fice, P.O. Box 3079, Sarasota, Florida
34230-3079, (941)861-7400,
at least seven (7) days before your
scheduled court appearance, or imme-
diately upon receiving this notification
if the time before the scheduled ap-
pearance is less than seven (7) days;
if you are hearing or voice impaired,
call 711.

Dated on May 14th, 2014.
KAREN E. RUSHING
As Clerk of the Court
(SEAL) By: L. Szymanski
As Deputy Clerk

ALDRIDGE | CONNORS, LLP
Plaintiff's Attorney
1615 South Congress Avenue,
Suite 200,
Delray Beach, FL 33445
Phone Number: (561) 392-6391
1113-12181
May 23, 30, 2014 14-02224S

FIRST INSERTION

NOTICE OF SALE
IN THE CIRCUIT COURT OF THE
TWELFTH JUDICIAL CIRCUIT
IN AND FOR SARASOTA COUNTY,
FLORIDA

Case No.: 58 2011 CA 0004642 NC
CITIMORTGAGE, INC.
Plaintiff, v.

RADA MILCEVIC AKA RADA
EDWARDS; CHRISTOPHER
EDWARDS; LARRY PATRICK
EDWARDS; AND ANY ALL
UNKNOWN PARTIES CLAIMING
BY, THROUGH, UNDER, AND
AGAINST THE HEREIN NAMED
INDIVIDUAL DEFENDANT(S)
WHO ARE NOT KNOWN TO BE
DEAD OR ALIVE, WHETHER
SAID UNKNOWN PARTIES
MAY CLAIM AN INTEREST AS
SPOUSES, HEIRS, DEVISEES,
GRANTEES, OR OTHER
CLAIMANTS; KENILWORTH
ESTATES HOMEOWNERS
ASSOCIATION, INC.; AND
TENANT
Defendant(s).

NOTICE IS HEREBY GIVEN pursu-
ant to an Order Granting Plaintiff's
Motion to Reset Foreclosure dated
April 21, 2014, entered in Civil Case
No. 58 2011 CA 0004642 NC of the
Circuit Court of the Twelfth Judicial
Circuit in and for Sarasota County,
Florida, wherein the Clerk of the Cir-
cuit Court will sell to the highest bidder
for cash on the 9th day of June, 2014,
at 9:00 a.m. online at the website:
<https://www.sarasota.realforeclose.com>,
relative to the following described
property as set forth in the Final Judg-
ment, to wit:

BEING AT THE SOUTH-
EAST CORNER OF BLOCK 47,
LORD'S ADDITION TO SARA-
SOTA, ACCORDING TO THE
PLAT THEREOF, AS RECORDED
IN PLAT BOOK 1, PAGE 194,
OF THE PUBLIC RECORDS OF
MANATEE COUNTY, FLORIDA,
AND PLAT BOOK A, PAGE 31,
PUBLIC RECORDS OF SARA-
SOTA COUNTY, FLORIDA;
THENCE NORTH ALONG THE

FIRST INSERTION

NOTICE OF FORECLOSURE SALE
IN THE CIRCUIT COURT OF THE
TWELFTH JUDICIAL CIRCUIT, IN
AND FOR SARASOTA COUNTY,
FLORIDA

CASE NO. 2010 CA 002358 NC
BAC HOME LOANS SERVICING,
LP FKA COUNTRYWIDE HOME
LOANS SERVICING LP,
Plaintiff, vs.

MICHAELA KOKESOVA, et al.
Defendants

NOTICE IS HEREBY GIVEN pursu-
ant to a Final Judgment of Foreclosure
dated May 12, 2014, and entered in
Case No. 2010 CA 002358 NC, of the
Circuit Court of the Twelfth Judicial
Circuit in and for SARASOTA County,
Florida. BANK OF AMERICA, NATION-
AL ASSOCIATION, is Plain-
tiff and MICHAELA KOKESOVA;
DARRIN GRIFFIN A/K/A DARREN
GRIFFIN; MORTGAGE ELECTRONIC
REGISTRATION SYSTEMS INCOR-
PORATED AS NOMINEE FOR
REAL TIME RESOLUTIONS, INC.;
CHARTLEY COURT HOMEOWN-
ERS ASSOCIATION, INC. are defend-
ants. The Clerk of Court will sell to
the highest and best bidder for cash via
the Internet at www.sarasota.realforeclose.com,
at 9:00 a.m., on the 17th day
of June, 2014, the following described
property as set forth in said Final Judg-
ment, to wit:

LOT 20, CHARTLEY COURT,
ACCORDING TO THE PLAT
THEREOF, AS RECORDED
IN PLAT BOOK 31, PAGE 24
AND 24A OF THE PUBLIC RE-
CORDS OF SARASOTA COUN-
TY, FLORIDA.

Any person claiming an interest in the
surplus from the sale, if any, other than
the property owner as of the date of the
Lis Pendens must file a claim within 60
days after the sale.

If you are a person with a disability
who needs any accommodation in order
to participate in this proceeding, you
are entitled, at no cost to you, to the
provision of certain assistance. Please
contact the Sarasota County Jury Of-
fice, P.O. Box 3079, Sarasota, Florida
34230-3079, (941)861-7400, at least
seven (7) days before your sched-
uled court appearance, or immedi-
ately upon receiving this notification
if the time before the scheduled
appearance is less than seven (7)
days; if you are hearing or voice
impaired, call 711.

Mark C. Elia, Esq.
Florida Bar #: 695734
Email: MCElia@vanlawfl.com

VAN NESS LAW FIRM, PLC
1239 E. Newport Center Drive,
Suite 110
Deerfield Beach, Florida 33442
Ph: (954) 571-2031
Fax: (954) 571-2033
PRIMARY EMAIL:
Pleadings@vanlawfl.com
May 23, 30, 2014 14-02237S

FIRST INSERTION

NOTICE OF ACTION
IN THE COUNTY COURT OF THE
TWELFTH JUDICIAL CIRCUIT
IN AND FOR SARASOTA COUNTY,
FLORIDA

CASE NO.: 2013 CC 005338 SC
CAMELOT COMMUNITIES MHP,
LLC d/b/a Camelot Lakes Mobile
Home Community,
Plaintiff, vs.

GLENN J. SILVERS, JACKIE L.
SILVERS and BANK OF AMERICA,
NATIONAL ASSOCIATION, AS
SUCCESSOR IN INTEREST TO
BARNETT BANK,
Defendants.

TO: Glenn J. Silvers
5893 Waterbury Circle
Sarasota, Florida 34233
Jackie L. Silvers
5893 Waterbury Circle
Sarasota, Florida 34233

YOU ARE NOTIFIED that an action
for money damages and lien foreclo-
sure upon a mobile home described as
that certain 1981 ELDO mobile home
bearing vehicle identification numbers
06222A and 06222B has been filed
against you, and you are required to
serve a copy of your written defenses,
if any, to Daniel M. Hartzog, Jr., Esq.,
plaintiff's attorney, whose address is
2002 East 4th Avenue, Tampa, Florida
33605, on or before June 23rd 2014,
and file the original with the Clerk
of this Court either before service on
plaintiff's attorney or immediately
thereafter; otherwise a default will be
entered against you for the relief de-
manded in the amended complaint or
petition.

If you are a person with a disability
who needs any accommodation in order
to participate in this proceeding, you
are entitled, at no cost to you, to the
provision of certain assistance. Please
contact the Sarasota County Jury Of-
fice, P.O. Box 3079, Sarasota, Florida
34230-3079, (941)861-7400, at least
seven (7) days before your scheduled
court appearance, or immediately upon
receiving this notification if the time
before the scheduled appearance is less
than seven (7) days; if you are hearing
or voice impaired, call 711.

WITNESS Karen E. Rushing, as
Clerk of the County Court, and the
seal of said Court, at the Courthouse at
Sarasota County, Florida.

Dated: 5-16-14
Karen E. Rushing,
Sarasota County Clerk of Court
2000 Main Street
Sarasota, Florida 34237
(SEAL) By: L. Szymanski
Deputy Clerk

Daniel M. Hartzog, Jr., Esq.
Plaintiff's Attorney
2002 East 4th Avenue
Tampa, Florida 33605
(813) 241-8269
May 23, 30, 2014 14-02229S

FIRST INSERTION

RE-NOTICE OF
FORECLOSURE SALE
IN THE CIRCUIT COURT OF THE
12TH JUDICIAL CIRCUIT, IN
AND FOR SARASOTA COUNTY,
FLORIDA

CIVIL DIVISION:
CASE NO.: 2009 CA 004859 NC

U.S. BANK NATIONAL
ASSOCIATION, AS TRUSTEE,
SUCCESSOR IN INTEREST TO
WACHOVIA BANK, NATIONAL
ASSOCIATION, AS TRUSTEE FOR
J.P. MORGAN MORTGAGE TRUST
2005-A8
Plaintiff, vs.

ANTHONY J. GUGINO; MARY
E. GUGINO; ANY AND ALL
UNKNOWN PARTIES CLAIMING
BY, THROUGH, UNDER, AND
AGAINST THE HEREIN NAMED
INDIVIDUAL DEFENDANT (S)
WHO ARE NOT KNOWN TO BE
DEAD OR ALIVE, WHETHER
SAID UNKNOWN PARTIES
MAY CLAIM AN INTEREST AS
SPOUSES, HEIRS, DEVISEES,
GRANTEES, OR OTHER
CLAIMANTS; CHASE MORTGAGE
SERVICES, INC. F/K/A CHASE
MANHATTAN MORTGAGE
CORPORATION A DISSOLVED
CORPORATION; THE VENICE
GOLF & COUNTRY CLUB
MASTER ASSOCIATION, INC.;
TENANT #1, TENANT #2, TENANT
#3, AND TENANT #4 the names
being fictitious to account for
parties in possession,
Defendants.

NOTICE IS HEREBY GIVEN pursu-
ant to an Order Resetting Foreclosure
Sale dated the 14th day of March,
2014, and entered in Case No. 2009
CA 004859 NC, of the Circuit Court
of the 12TH Judicial Circuit in and
for Sarasota County, Florida, wherein
U.S. BANK NATIONAL ASSOCIA-
TION, AS TRUSTEE, SUCCESSOR
IN INTEREST TO WACHOVIA
BANK, NATIONAL ASSOCIATION,
AS TRUSTEE FOR J.P. MOR-
GAN MORTGAGE TRUST 2005-
A8 is the Plaintiff and ANTHONY
J. GUGINO; MARY E. GUGINO;
CHASE MORTGAGE SERVICES,
INC. F/K/A CHASE MANHATTAN
MORTGAGE CORPORATION A

FIRST INSERTION

NOTICE OF ACTION
IN THE CIRCUIT COURT
OF THE TWELFTH JUDICIAL
CIRCUIT OF FLORIDA IN AND FOR
SARASOTA COUNTY

CASE NO. 2013 CA 008252 NC
CALIBER HOME LOANS, INC.,
Plaintiff, vs.

CARLYLE E. VEALE, et al,
Defendants,

To the following Defendant(s):
UNKNOWN TRUSTEES,SETTLERS
AND BENEFICIARIES OF CARLYLE
E. VEALE LIVING REVOCABLE
TRUST DATED 11/23/2007

YOU ARE NOTIFIED that an action
for Foreclosure of Mortgage on the fol-
lowing described property:

LOT 18, BLOCK G, LA LINDA
TERRACE, ACCORDING TO
THE PLAT THEREOF, AS RE-
CORDED N PLAT BOOK 1,
PAGE 85, OF THE PUBLIC RE-
CORDS OF SARASOTA COUN-
TY, FLORIDA.

has been filed against you and you are
required to file a copy of your written
defenses, if any, to it, on McCalla Ray-
mer, LLC, Brian R. Hummel, Attorney
for Plaintiff, whose address is 225 East
Robinson Street, Suite 660, Orlando,
FL 32801 on or before 6-23-2014, a
date which is within thirty (30) days af-
ter the first publication of this Notice in
The Business Observer (Sarasota/Lee/
Manatee) and file the original with the
Clerk of this Court either before ser-
vice on Plaintiff's attorney or immedi-
ately thereafter; otherwise a default will
be entered against you for the relief de-
manded in the complaint.

If you are a person with a disability
who needs any accommoda-
tion in order to participate in this
proceeding, you are entitled, at no
cost to you, to the provision of cer-
tain assistance. Please contact the
Sarasota County Jury Office, P.O. Box
3079, Sarasota, Florida 34230-3079,
(941)861-7400, at least seven (7) days
before your scheduled court appear-
ance, or immediately upon receiving
this notification if the time before
the scheduled appearance is less than
seven (7) days; if you are hearing or
voice impaired, call 711.

WITNESS my hand and seal of this
Court this 13 day of May, 2014.

KAREN E. RUSHING, CLERK
Clerk of the Court
(SEAL) By G. Kopinsky
As Deputy Clerk

MCCALLA RAYMER, LLC
225 E. Robinson St.
Suite-660
Orlando, FL 32801
Phone: (407) 674-1850
Email:
MRSservice@mccallaraymer.com
2516261
13-05035-1
May 23, 30, 2014 14-02232S

FIRST INSERTION

NOTICE OF FORECLOSURE SALE
IN THE CIRCUIT COURT OF THE
TWELFTH JUDICIAL CIRCUIT
IN AND FOR SARASOTA COUNTY,
FLORIDA

CIVIL ACTION
CASE NO.: 58-2012-CA-002398 NC
DIVISION: A

BANK OF AMERICA, N.A., AS
SUCCESSOR BY MERGER TO
BAC HOME LOANS SERVICING,
LP FKA COUNTRYWIDE HOME
LOANS SERVICING, LP,
Plaintiff, vs.

LINDA E. HUNT, et al,
Defendant(s).

NOTICE IS HEREBY GIVEN pursuant
to a Final Judgment of Mortgage
Foreclosure dated May 12, 2014 and
entered in Case No. 58-2012-CA-
002398 NC of the Circuit Court of the
TWELFTH Judicial Circuit in and for
SARASOTA County, Florida wherein
BANK OF AMERICA, N.A., AS
SUCCESSOR BY MERGER TO BAC
HOME LOANS SERVICING, LP FKA
COUNTRYWIDE HOME LOANS
SERVICING, LP is the Plaintiff and
THE UNKNOWN HEIRS, DEVISEES,
GRANTEES, ASSIGNEES, LIENORS,
CREDITORS, TRUSTEES, OR
OTHER CLAIMANTS CLAIMING
BY, THROUGH, UNDER, OR
AGAINST, LINDA E. HUNT A/K/A
LINDA EDITH HUNT A/K/A
LINDA HUNT, DECEASED;
CHRISTOPHER SCOTT HUNT
A/K/A CHRISTOPHER S. HUNT
AS HEIR OF THE ESTATE OF
LINDA E. HUNT A/K/A LINDA
EDITH HUNT A/K/A LINDA
HUNT, DECEASED; ANY AND ALL
UNKNOWN PARTIES CLAIMING
BY, THROUGH, UNDER, AND
AGAINST THE HEREIN NAMED
INDIVIDUAL DEFENDANT(S)
WHO ARE NOT KNOWN TO BE
DEAD OR ALIVE, WHETHER
SAID UNKNOWN PARTIES MAY
CLAIM AN INTEREST AS SPOUSES,
HEIRS, DEVISEES, GRANTEES,
OR OTHER CLAIMANTS; BANK

OF AMERICA, NA; JOCKEY CLUB
OF NORTH PORT PROPERTY
OWNERS' ASSOCIATION, INC.;
TENANT #1 N/K/A AUBREY
THORNE are the Defendants, The
Clerk will sell to the highest and best
bidder for cash at WWW.SARASOTA.
REALFORECLOSE.COM at 9:00AM,
on the 16th day of June, 2014, the
following described property as set
forth in said Final Judgment:

LOT 32, BLOCK 2646,
FIFTY-SECOND ADDITION
TO PORT CHARLOTTE
SUBDIVISION, ACCORDING
TO THE PLAT THEREOF,
RECORDED IN PLAT BOOK
21, PAGE 13, OF THE PUBLIC
RECORDS OF SARASOTA
COUNTY, FLORIDA.

A/K/A 6764 DENNISON
AVENUE, NORTH PORT, FL
34287

Any person claiming an interest in the
surplus from the sale, if any, other than
the property owner as of the date of the
Lis Pendens must file a claim within
sixty (60) days after the sale.

If you are a person with a disability
who needs any accommodation in
order to participate in this proceeding,
you are entitled, at no cost to you, to
the provision of certain assistance. Please
contact the Sarasota County Jury Of-
fice, P.O. Box 3079, Sarasota, Florida
34230-3079, (941)861-7400, at least
seven (7) days before your sched-
uled court appearance, or immedi-
ately upon receiving this notification
if the time before the scheduled ap-
pearance is less than seven (7) days;
if you are hearing or voice impaired,
call 711.

By: J. Bennett Kitterman
Florida Bar No. 98636
Ronald R Wolfe & Associates, P.L.
P.O. Box 25018
Tampa, Florida 33622-5018
(813) 251-4766
(813) 251-1541 Fax
F10105367
May 23, 30, 2014 14-02241S

FIRST INSERTION

NOTICE OF FORECLOSURE SALE IN THE CIRCUIT COURT IN AND FOR SARASOTA COUNTY, FLORIDA

CASE NO: 2012 CA 003811 NC GREEN TREE SERVICING LLC Plaintiff, vs. MICHELLE PHILLIPS; RODNEY SCHEELE; UNKNOWN SPOUSE OF MICHELLE PHILLIPS; UNKNOWN SPOUSE OF RODNEY SCHEELE; UNKNOWN TENANT I; UNKNOWN TENANT II; THE HOUSING AUTHORITY OF THE CITY OF SARASOTA, FLORIDA; SARASOTA COUNTY, A POLITICAL SUBDIVISION OF THE STATE OF FLORIDA, and any unknown heirs, devisees, grantees, creditors, and other unknown persons or unknown spouses claiming by, through and under any of the above-named Defendants, Defendants.

NOTICE is hereby given that the Clerk of the Circuit Court of Sarasota County, Florida, will on the 6th day of June, 2014, at 9:00 AM, at www.sarasota.realforeclose.com, in accordance with Chapter 45 Florida Statutes, offer for sale and sell at public outcry to the highest and best bidder for cash, the following-described property situate in Sarasota County, Florida:

LOT 1348, SARASOTA SPRINGS, UNIT NO. 12, ACCORDING TO THE PLAT THEREOF RECORDED IN PLAT BOOK 8, PAGE 42, OF THE PUBLIC RECORDS OF SARASOTA COUNTY, FLORIDA.

pursuant to the Final Judgment entered in a case pending in said Court, the style of which is indicated above.

Any person or entity claiming an interest in the surplus, if any, resulting from the foreclosure sale, other than the property owner as of the date of the Lis Pendens, must file a claim on same with the Clerk of Court within 60 days after the foreclosure sale.

If you are a person with a disability who needs any accommodation in order to participate in this proceeding, you are entitled, at no cost to you, to the provision of certain assistance. Please contact the Sarasota County Jury Office, P.O. Box 3079, Sarasota, Florida 34230-3079, (941)861-7400, at least seven (7) days before your scheduled court appearance, or immediately upon receiving this notification if the time before the scheduled appearance is less than seven (7) days; if you are hearing or voice impaired, call 711

DATED this 14 day of May, 2014.

Chris Bertels, Esquire
Florida Bar No: 98267
Amanda Ann Shough, Esquire
Florida Bar No: 107073

BUTLER & HOSCH, P.A.
3185 South Conway Road, Suite E
Orlando, Florida 32812
Telephone: (407) 381-5200
Fax: (407) 381-5577
Florida Bar No: 103300
as107073@butlerandhosch.com
FLPleadings@butlerandhosch.com
B&H # 312969
May 23, 30, 2014 14-02229S

FIRST INSERTION

NOTICE OF ACTION IN THE CIRCUIT COURT OF THE 12TH JUDICIAL CIRCUIT, IN AND FOR SARASOTA COUNTY, FLORIDA

CIVIL DIVISION
CASE NO.: 2013 CA 003792 NC FEDERAL NATIONAL MORTGAGE ASSOCIATION, Plaintiff, vs. UNKNOWN HEIRS, BENEFICIARIES, DEVISEES, ASSIGNEES, LIENORS, CREDITORS, TRUSTEES AND ALL OTHERS WHO MAY CLAIM AN INTEREST IN THE ESTATE OF FREDERICK EDWARD RUEGER, JR., et al., Defendants.

TO: UNKNOWN HEIRS, BENEFICIARIES, DEVISEES, ASSIGNEES, LIENORS, CREDITORS, TRUSTEES AND ALL OTHERS WHO MAY CLAIM AN INTEREST IN THE ESTATE OF FREDERICK EDWARD RUEGER, JR., et al.,

Last Known Address: UNKNOWN
Current Address: UNKNOWN
YOU ARE NOTIFIED that an action for Foreclosure of Mortgage on the following described property:

LOTS 17 AND 19, BLOCK E, OF RIDGEWOOD, ACCORDING TO THE PLAT THEREOF, RECORDED IN PLAT BOOK 1, PAGE 132, OF THE PUBLIC RECORDS OF SARASOTA COUNTY, FLORIDA

has been filed against you and you are required to serve a copy of your written defenses, if any, to it, on Choice Legal Group, P.A., Attorney for Plaintiff, whose address is P.O. BOX 9908, FT. LAUDERDALE, FL 33310-0908 on or before June 23rd, 2014, a date which is within thirty (30) days after the first publication of this Notice in the BUSINESS OBSERVER and file the original with the Clerk of this Court either before service on Plaintiff's attorney or immediately thereafter; otherwise a default will be entered against you for the relief demanded in the complaint.

If you are a person with a disability who needs any accommodation in order to participate in this proceeding, you are entitled, at no cost to you, to the provision of certain assistance. Please contact the Sarasota County Jury Office, P.O. Box 3079, Sarasota, Florida 34230-3079, (941)861-7400, at least seven (7) days before your scheduled court appearance, or immediately upon receiving this notification if the time before the scheduled appearance is less than seven (7) days; if you are hearing or voice impaired, call 711.

WITNESS my hand and the seal of this Court this 16th day of May, 2014.

KAREN E. RUSHING
As Clerk of the Court
(SEAL) By: L. Szymanski
As Deputy Clerk

Choice Legal Group, P.A.,
Attorney for Plaintiff
P.O. Box 9908
Fort Lauderdale, FL 33310-9908
12-08786
May 23, 30, 2014 14-02293S

FIRST INSERTION

NOTICE OF ACTION IN THE CIRCUIT COURT IN AND FOR SARASOTA COUNTY, FLORIDA

CASE NO: 2013 CA 007681 NC NATIONSTAR MORTGAGE LLC D.B.A CHAMPION MORTGAGE COMPANY Plaintiff, vs. THE UNKNOWN HEIRS, DEVISEES, GRANTEES, ASSIGNEES, LIENORS, CREDITORS, TRUSTEES, AND OTHER UNKNOWN PERSONS OR UNKNOWN SPOUSES CLAIMING BY, THROUGH, UNDER OR AGAINST DESPINA SPYRIDAKOS, DECEASED, ET AL., Defendants.

TO: THE UNKNOWN HEIRS, DEVISEES, GRANTEES, ASSIGNEES, LIENORS, CREDITORS, TRUSTEES, AND OTHER UNKNOWN PERSONS OR UNKNOWN SPOUSES CLAIMING BY, THROUGH, UNDER OR AGAINST DESPINA SPYRIDAKOS, DECEASED
LAST KNOWN ADDRESS STATED, CURRENT RESIDENCE UNKNOWN
YOU ARE HEREBY NOTIFIED that an action to foreclose Mortgage covering the following real and personal property described as follows, to-wit:

LOT 11, BLOCK 27, SOUTH GATE, UNIT NO. 9, AS PER PLAT THEREOF RECORDED IN PLAT BOOK 8, PAGE 81, OF THE PUBLIC RECORDS OF SARASOTA COUNTY, FLORIDA.

has been filed against you and you are required to serve a copy of your written defenses, if any, to it on Amanda A. Shough, Butler & Hosch, P.A., 3185 South Conway Road, Suite E, Orlando, Florida 32812 and file the original with the Clerk of the above-styled Court on or before 30 days from the first publication, otherwise a Judgment may be entered against you for the relief demanded in the Complaint.

If you are a person with a disability who needs any accommodation in order to participate in this proceeding, you are entitled, at no cost to you, to the provision of certain assistance. Please contact the Sarasota County Jury Office, P.O. Box 3079, Sarasota, Florida 34230-3079, (941)861-7400, at least seven (7) days before your scheduled court appearance, or immediately upon receiving this notification if the time before the scheduled appearance is less than seven (7) days; if you are hearing or voice impaired, call 711.

WITNESS my hand and seal of said Court on the 12 day of May, 2014.

KAREN E. RUSHING, CLERK
CLERK OF THE CIRCUIT COURT
(COURT SEAL) By: G. Kopinsky
Deputy Clerk

Amanda A. Shough
Butler & Hosch, P.A.
3185 South Conway Road, Suite E
Orlando, Florida 32812
B&H # 337579
May 23, 30, 2014 14-02230S

FIRST INSERTION

NOTICE OF FORECLOSURE SALE IN THE CIRCUIT COURT OF THE TWELFTH JUDICIAL CIRCUIT IN AND FOR SARASOTA COUNTY, FLORIDA

Case No: 2013-CA-009023-NC CHRISTIANA TRUST, A DIVISION OF WILMINGTON SAVINGS FUND SOCIETY, FSB, AS TRUSTEE FOR STANWICH MORTGAGE LOAN TRUST, SERIES 2012-13, Plaintiff, vs. GLENN WALTRIP, ET AL. Defendants.

NOTICE IS HEREBY GIVEN that pursuant to the Final Judgment of Foreclosure dated May 12, 2014, and entered in Case No. 2013-CA-009023-NC of the Circuit Court of the Twelfth Judicial Circuit in and for Sarasota County, Florida wherein CHRISTIANA TRUST, A DIVISION OF WILMINGTON SAVINGS FUND SOCIETY, FSB, AS TRUSTEE FOR STANWICH MORTGAGE LOAN TRUST, SERIES 2012-13, is the Plaintiff and GLENN WALTRIP, ET AL. are the Defendant's, I will sell to the highest and best bidder for cash www.sarasota.realforeclose.com at 9:00 AM on or as soon as possible on June 18, 2014 the following described property set forth in said Final Judgment, to wit:

LOT 6, BLOCK 574, 18TH ADDITION TO PORT CHARLOTTE SUBDIVISION, A SUBDIVISION ACCORDING TO THE PLAT THEREOF, RECORDED IN PLAT BOOK 14, PAGES 6, 6A THROUGH 6V, OF THE PUBLIC RECORDS OF SARASOTA COUNTY, FLORIDA.

Any person or entity claiming an interest in the surplus, if any, resulting from the Foreclosure Sale, other than the property owner as of the date of the Lis Pendens, must file a claim on same with the Clerk of Court within sixty (60) days after the Foreclosure Sale.

If you are a person with a disability who needs any accommodation in order to participate in this proceeding, you are entitled, at no cost to you, to the provision of certain assistance. Please contact the Sarasota County Jury Office, P.O. Box 3079, Sarasota, Florida 34230-3079, (941)861-7400, at least seven (7) days before your scheduled court appearance, or immediately upon receiving this notification if the time before the scheduled appearance is less than seven (7) days; if you are hearing or voice impaired, call 711.

DATED May 13, 2014

/s/ Nancy Alvarez
Nancy Alvarez, Esq.
Florida Bar No. 068122

Lender Legal Services, LLC
201 East Pine Street, Suite 730
Orlando, Florida 32801
Tel: (407) 730-4644
Fax: (888) 337-3815
Attorney for Plaintiff
nalvarez@lenderlegal.com
EService@LenderLegal.com
May 23, 30, 2014 14-02231S

FIRST INSERTION

NOTICE OF ACTION IN THE CIRCUIT COURT OF THE TWELFTH JUDICIAL CIRCUIT IN AND FOR SARASOTA COUNTY, FLORIDA

CIVIL DIVISION
Case No.: 2013-CA-008620 410 52nd AVE DR, LLC, a Florida Limited Liability Company Plaintiff, vs. CITY OF NORTH PORT, FLORIDA, ET AL., Defendants.

TO: DEBORAH SMITH ALDRIDGE A/K/A DEBORAH S. ALDRIDGE 1447 STRADA D ORO VENICE, FL 34292

YOU ARE HEREBY NOTIFIED that an action for foreclosure of lien on the following described property:

LOT 2, BLOCK 2499, FIFTEETH ADDITION TO PORT CHARLOTTE SUBDIVISION, A SUBDIVISION ACCORDING TO THE PLAT THEREOF, AS RECORDED IN PLAT BOOK 21, PAGES 7, 7A-7H, OF THE PUBLIC RECORDS OF SARASOTA COUNTY, FLORIDA.
Property Address: 5826 Gabo Road, North Port, FL 34287
Parcel ID: 1000-24-9902

Has been filed against you, and that you are required to serve a copy of your written defenses, if any, to it on STEVEN H. MEZER, ESQUIRE, Plaintiff's attorney, whose address is Bush Ross P.A., Post Office Box 3913, Tampa, FL 33601, on or before June 23, 2014, a date within 30 days after the first publication of the notice and file the original with the Clerk of this Court either before service on Plaintiff's attorney or immediately thereafter; otherwise a default will be entered against you for the relief demanded in the complaint or petition.

If you are a person with a disability who needs any accommodation in order to participate in this proceeding, you are entitled, at no cost to you, to the provision of certain assistance. Please contact the Sarasota County Jury Office, P.O. Box 3079, Sarasota, Florida 34230-3079, (941)861-7400, at least seven (7) days before your scheduled court appearance, or immediately upon receiving this notification if the time before the scheduled appearance is less than seven (7) days; if you are hearing or voice impaired, call 711.

DATED on May 9, 2014.

KAREN RUSHING
As Clerk of the Court
(SEAL) By C. Brandenburg
Deputy Clerk

Steven H. Mezer, Esquire
Florida Bar No. 239186
Bush Ross PA
P.O. Box 3913
Tampa, Florida 33601
(813) 204-6404
Attorney for Plaintiff
1661416.v1
May 23, 30, 2014 14-02226S

FIRST INSERTION

NOTICE OF ACTION IN THE CIRCUIT COURT OF THE TWELFTH JUDICIAL CIRCUIT OF FLORIDA IN AND FOR SARASOTA COUNTY

GENERAL JURISDICTION DIVISION

CASE NO. 58-2014-CA-001365 NC GREEN TREE SERVICING LLC, Plaintiff, vs. WILLIAM G. TEETS, CHARLOTTE TEETS, UNKNOWN TENANT IN POSSESSION 1, UNKNOWN TENANT IN POSSESSION 2, Defendants.

TO: WILLIAM G. TEETS 3890 FROUDE STREET, NORTH PORT, FL 34286
LAST KNOWN ADDRESS STATED, CURRENT RESIDENCE UNKNOWN
YOU ARE NOTIFIED that an action to foreclose Mortgage covering the following real and personal property described as follows, to-wit:

LOTS 21 AND 22, BLOCK 529, 11TH ADDITION TO PORT CHARLOTTE SUBDIVISION, A SUBDIVISION ACCORDING TO THE PLAT THEREOF, AS RECORDED IN PLAT BOOK 13, AT PAGES 2, 2A THROUGH 2I, OF THE PUBLIC RECORDS OF SARASOTA COUNTY, FLORIDA.

has been filed against you and you are required to file a copy of your written defenses, if any, to it, on Brian Hummel, Esq., McCalla Raymer, LLC, 225 E. Robinson St. Suite 660, Orlando, FL 32801 and file the original with the Clerk of the above-styled Court on or before 30 days from the first publication, otherwise a Judgment may be entered against you for the relief demanded in the Complaint.

If you are a person with a disability who needs any accommodation in order to participate in this proceeding, you are entitled, at no cost to you, to the provision of certain assistance. Please contact the Sarasota County Jury Office, P.O. Box 3079, Sarasota, Florida 34230-3079, (941)861-7400, at least seven (7) days before your scheduled court appearance, or immediately upon receiving this notification if the time before the scheduled appearance is less than seven (7) days; if you are hearing or voice impaired, call 711.

WITNESS my hand and seal of said Court on the 14th day of May, 2014.

KAREN E. RUSHING, CLERK
CLARK OF THE CIRCUIT COURT

As Clerk of the Court
(SEAL) BY: L. Szymanski
Deputy Clerk

MCCALLA RAYMER, LLC
225 E. Robinson St. Suite-660
Orlando, FL 32801
Phone: (407) 674-1850
Fax: (321) 248-0420
Email:
MRService@mccallaraymer.com
2806670
13-09612-1
May 23, 30, 2014 14-02233S

FIRST INERTION

NOTICE OF ACTION IN THE CIRCUIT COURT OF THE TWELFTH JUDICIAL CIRCUIT IN AND FOR SARASOTA COUNTY, FLORIDA

CIVIL ACTION
CASE NO.: 58-2013-CA-007075 NC WELLS FARGO BANK, N.A., Plaintiff, vs. SAM FARRA, et al, Defendant(s).

To: SAM FARRA THE UNKNOWN SPOUSE OF SAM FARRA

Last Known Address: 7 Durie Lane Thornhill, Ontario L3T5H4

Current Address: Unknown
ANY AND ALL UNKNOWN PARTIES CLAIMING BY, THROUGH, UNDER, AND AGAINST THE HEREIN NAMED INDIVIDUAL DEFENDANT(S) WHO ARE NOT KNOWN TO BE DEAD OR ALIVE, WHETHER SAID UNKNOWN PARTIES MAY CLAIM AN INTEREST AS SPOUSES, HEIRS, DEVISEES, GRANTEES, OR OTHER CLAIMANTS

Last Known Address: Unknown
Current Address: Unknown

YOU ARE NOTIFIED that an action to foreclose a mortgage on the following property in Sarasota County, Florida:

LOT 21, BLOCK F, DESOTO ACRES, AS PER PLAT THEREOF, RECORDED IN PLAT BOOK 4, PAGES 41 AND 42, OF THE PUBLIC RECORDS OF SARASOTA COUNTY, FLORIDA.
A/K/A 53RD ST. LOT 21,

BLOCK F, SARASOTA, FL 34234

has been filed against you and you are required to serve a copy of your written defenses within 30 days after the first publication, if any, on Albertelli Law, Plaintiff's attorney, whose address is P.O. Box 23028, Tampa, FL 33623, and file the original with this Court either before June 16th, 2014 service on Plaintiff's attorney, or immediately thereafter; otherwise, a default will be entered against you for the relief demanded in the Complaint or petition.

This notice shall be published once a week for two consecutive weeks in the Business Observer.

If you are a person with a disability who needs any accommodation in order to participate in this proceeding, you are entitled, at no cost to you, to the provision of certain assistance. Please contact the Sarasota County Jury Office, P.O. Box 3079, Sarasota, Florida 34230-3079, (941)861-7400, at least seven (7) days before your scheduled court appearance, or immediately upon receiving this notification if the time before the scheduled appearance is less than seven (7) days; if you are hearing or voice impaired, call 711.

WITNESS my hand and the seal of this court on this 16th day of May, 2014.

KAREN E. RUSHING, CLERK
Clerk of the Circuit Court
(SEAL) By: L. Szymanski
Deputy Clerk

Albertelli Law
P.O. Box 23028
Tampa, FL 33623
EF-13-111136
May 23, 30, 2014 14-02291S

FIRST INERTION

NOTICE OF ACTION IN THE CIRCUIT COURT OF THE TWELFTH JUDICIAL CIRCUIT IN AND FOR

SARASOTA COUNTY, FLORIDA
Case No. 2014-CA-001199 NC GREEN PLANET SERVICING, LLC., Plaintiff, vs.

WILLIAM GLOVER; UNKNOWN SPOUSE OF WILLIAM GLOVER; et al., Defendant(s).

TO: UNKNOWN SPOUSE OF WILLIAM GLOVER 4037 Iola Drive Sarasota, FL 34231

If he/she/they are living and if he/she/they are dead, any unknown Defendants, who may be spouses, heirs, beneficiaries devisees, grantees, assignees, lienors, creditors, trustees, and all other parties claiming an interest by, through, under or against the named Defendant(s), who is/are not known to be dead or alive, and all parties having or claiming to have any right, title or interest in the property described in the mortgage being foreclosed herein.

YOU ARE HEREBY NOTIFIED that an action to foreclose a mortgage on the following real property in Sarasota County, Florida:

LOT 20, BLOCK "C" DIXIE HEIGHTS SUBDIVISION, ACCORDING TO THE PLAT THEREOF RECORDED IN PLAT BOOK 1 PAGE 147 PUBLIC RECORDS OF SARASOTA COUNTY, FLORIDA.

Commonly Known As: 4037 Iola Drive, Sarasota, FL 34231
has been filed against you and you are

required to file a copy of your written defenses, if any, to it, on IRA SCOT SILVERSTEIN, ESQUIRE, IRA SCOT SILVERSTEIN, LLC, Plaintiff's attorney, whose address is 2900 West Cypress Creek Road Suite 6, Fort Lauderdale, Florida 33309, within thirty (30) days after the first publication of this Notice, and file the original with the Clerk of this Court either before service on Plaintiff's attorney or immediately thereafter; otherwise a default will be entered against you for the relief demanded in the Complaint.

This Notice shall be published once each week for two consecutive weeks in the Business Observer.

If you are a person with a disability who needs any accommodation in order to participate in this proceeding, you are entitled, at no cost to you, to the provision of certain assistance. Please contact the Sarasota County Jury Office, P.O. Box 3079, Sarasota, Florida 34230-3079, (941)861-7400, at least seven (7) days before your scheduled court appearance, or immediately upon receiving this notification if the time before the scheduled appearance is less than seven (7) days; if you are hearing or voice impaired, call 711.

WITNESS my hand and seal of this Court this 13th day of May, 2014.

KAREN E. RUSHING, CLERK
Clerk of Court, Sarasota County
(Circuit Court Seal)

By: L. Szymanski
As Deputy Clerk

IRA SCOT SILVERSTEIN, ESQUIRE
IRA SCOT SILVERSTEIN, LLC
2900 West Cypress Creek Road
Suite 6,
Fort Lauderdale, Florida 33309
May 23, 30, 2014 14-02236S

FIRST INERTION

NOTICE OF FORECLOSURE SALE IN THE CIRCUIT COURT OF THE TWELFTH JUDICIAL CIRCUIT IN AND FOR SARASOTA COUNTY, FLORIDA

CIVIL ACTION
CASE NO.: 58-2008-CA-019965-NC DIVISION: A

THE BANK OF NEW YORK MELLON TRUST COMPANY NA, FKA THE BANK OF NEW YORK TRUST COMPANY, NA AS SUCCESSOR IN INTEREST TO JP MORGAN CHASE BANK, NA, AS TRUSTEE FOR NOMURA ASSET ACCEPTANCE CORPORATION, ALTERNATIVE LOAN TRUST SERIES 2005-AR2, Plaintiff, vs. RONALD C. SLOBODA, et al, Defendant(s).

NOTICE IS HEREBY GIVEN pursuant to a Final Judgment of Mortgage Foreclosure dated May 12, 2014 and entered in Case No. 58-2008-CA-019965-NC of the Circuit Court of the TWELFTH Judicial Circuit in and for SARASOTA County, Florida wherein THE BANK OF NEW YORK MELLON TRUST COMPANY NA, FKA THE BANK OF NEW YORK TRUST COMPANY, NA AS SUCCESSOR IN INTEREST TO JP MORGAN CHASE BANK, NA, AS TRUSTEE FOR NOMURA ASSET ACCEPTANCE CORPORATION, ALTERNATIVE LOAN TRUST SERIES 2005-AR2 is the Plaintiff and RONALD C SLOBODA; MORTGAGE ELECTRONIC REGISTRATION SYSTEMS, INCORPORATED, AS NOMINEE FOR FIRST GUARANTY MORTGAGE CORPORATION; are the Defendants. The Clerk will sell to the highest and best bidder for cash at WWW.SARASOTA.

REALFORECLOSE.COM at 9:00AM, on the 17th day of June, 2014, the following described property as set forth in said Final Judgment:

LOT 10, BLOCK 6, PORT CHARLOTTE, ACCORDING TO THE PLAT THEREOF AS RECORDED IN PLAT BOOK 10, PAGES 95, 95A THROUGH 95D, INCLUSIVE, OF THE PUBLIC RECORDS OF SARASOTA COUNTY, FLORIDA

A/K/A 7900 SYDNEY AVENUE, NORTH PORT, FL 34287

Any person claiming an interest in the surplus from the sale, if any, other than the property owner as of the date of the Lis Pendens must file a claim within sixty (60) days after the sale.

If you are a person with a disability who needs any accommodation in order to participate in this proceeding, you are entitled, at no cost to you, to the provision of certain assistance. Please contact the Sarasota County Jury Office, P.O. Box 3079, Sarasota, Florida 34230-3079, (941)861-7400, at least seven (7) days before your scheduled court appearance, or immediately upon receiving this notification if the time before the scheduled appearance is less than seven (7) days; if you are hearing or voice impaired, call 711.

By: Victoria S. Jones
Florida Bar No. 52252

Ronald R Wolfe & Associates, P.L.
P.O. Box 25018
Tampa, Florida 33622-5018
(813) 251-4766
(813) 251-1541 Fax
F08107172
May 23, 30, 2014 14-02243S

SAVE TIME
E-mail your Legal Notice

legal@businessobserverfl.com

Wednesday Noon Deadline • Friday Publication

Business Observer

LV4681

FIRST INERTION

NOTICE OF ACTION
IN THE CIRCUIT COURT OF THE
TWELFTH JUDICIAL CIRCUIT
IN AND FOR SARASOTA COUNTY,
FLORIDA

CIVIL ACTION
CASE NO.: 58-2013-CA-008482NC
DIVISION: A

WELLS FARGO BANK, N.A.,
Plaintiff, vs.
CHARLENE ANN
LATIMER-MACDONNELL, et al,
Defendant(s).

To:
CHARLENE ANN
LATIMER-MACDONNELL
THE UNKNOWN SPOUSE OF
CHARLENE ANN
LATIMER-MACDONNELL
RALSTON E. MACDONNELL
THE UNKNOWN SPOUSE OF
RALSTON E. MACDONNELL
Last Known Address: 1173 South Park
Street
Halifax, NS, B3H 2W9
Canada

Current Address: Unknown
ANY AND ALL UNKNOWN PARTIES CLAIMING BY, THROUGH, UNDER, AND AGAINST THE HEREIN NAMED INDIVIDUAL DEFENDANT(S) WHO ARE NOT KNOWN TO BE DEAD OR ALIVE, WHETHER SAID UNKNOWN PARTIES MAY CLAIM AN INTEREST AS SPOUSES, HEIRS, DEVISEES, GRANTEEES, OR OTHER CLAIMANTS

Last Known Address: Unknown
Current Address: Unknown

YOU ARE NOTIFIED that an action to foreclose a mortgage on the following property in Sarasota County, Florida:

UNIT NUMBER 1006, THE BEACHES OF LONGBOAT KEY SOUTH, PHASE I, A CONDOMINIUM ACCORDING TO THE DECLARATION OF CONDOMINIUM RECORDED IN OFFICIAL RECORDS BOOK 1647, PAGE

1812, AS AMENDED, AND AS PER PLAT THEREOF RECORDED IN CONDOMINIUM BOOK 21, PAGE 42, OF THE PUBLIC RECORDS OF SARASOTA COUNTY, FLORIDA. TOGETHER WITH PARKING SPACE NO. 239.

A/K/A 775 LONGBOAT KEY CLUB RD UNIT 1006, LONGBOAT KEY, FL 34228

has been filed against you and you are required to serve a copy of your written defenses within 30 days after the first publication, if any, on Albertelli Law, Plaintiff's attorney, whose address is P.O. Box 23028, Tampa, FL 33623, and file the original with this Court either before 6-23-14 service on Plaintiff's attorney, or immediately thereafter; otherwise, a default will be entered against you for the relief demanded in the Complaint or petition.

This notice shall be published once a week for two consecutive weeks in the Business Observer.

If you are a person with a disability who needs any accommodation in order to participate in this proceeding, you are entitled, at no cost to you, to the provision of certain assistance. Please contact the Sarasota County Jury Office, P.O. Box 3079, Sarasota, Florida 34230-3079, (941)861-7400, at least seven (7) days before your scheduled court appearance, or immediately upon receiving this notification if the time before the scheduled appearance is less than seven (7) days; if you are hearing or voice impaired, call 711.

WITNESS my hand and the seal of this court on this 13 day of May, 2014.

KAREN E. RUSHING, CLERK
Clerk of the Circuit Court
(SEAL) By: C. Brandenburg
Deputy Clerk

Albertelli Law
P.O. Box 23028
Tampa, FL 33623
JR-13-117526
May 23, 30, 2014 14-02223S

FIRST INERTION

NOTICE OF ACTION
IN THE CIRCUIT COURT OF THE
TWELFTH JUDICIAL CIRCUIT
IN AND FOR SARASOTA COUNTY,
FLORIDA

CIVIL ACTION
CASE NO.: 58-2014-CA-000778 NC
DIVISION: C

THE BANK OF NEW YORK
MELLON F/K/A THE BANK OF
NEW YORK, AS
SUCCESSOR-IN-INTEREST TO
JPMORGAN CHASE BANK, N.A.,
F/K/A JPMORGAN CHASE BANK
AS TRUSTEE FOR STRUCTURED
ASSET MORTGAGE
INVESTMENTS II INC.,
GREENPOINT MTA TRUST
2005-AR1, MORTGAGE
PASS-THROUGH CERTIFICATES,
SERIES 2005-AR1,
Plaintiff, vs.
DSM, LLC, et al,
Defendant(s).

To:
JOHN DESYLVESTER
Last Known Address: 2601 Gulf Drive
North Lot S2
Bradenton Beach, FL 34217

Current Address: Unknown
ANY AND ALL UNKNOWN PARTIES CLAIMING BY, THROUGH, UNDER, AND AGAINST THE HEREIN NAMED INDIVIDUAL DEFENDANT(S) WHO ARE NOT KNOWN TO BE DEAD OR ALIVE, WHETHER SAID UNKNOWN PARTIES MAY CLAIM AN INTEREST AS SPOUSES, HEIRS, DEVISEES, GRANTEEES, OR OTHER CLAIMANTS

Last Known Address: Unknown
Current Address: Unknown

YOU ARE NOTIFIED that an action to foreclose a mortgage on the following property in Sarasota County, Florida:

LOT 10, LESS THE NORTH 10 INCHES OF LOT 10, BLOCK A, DESOTO TERRACE, BEING

A SUBDIVISION OF LOTS 53, 69, AND 73, INDIAN BEACH, ACCORDING TO THE PLAT THEREOF AS RECORDED IN PLAT BOOK A, PAGE 43, OF THE PUBLIC RECORDS OF SARASOTA COUNTY, FLORIDA

A/K/A 3804 IROQUOIS DR, SARASOTA, FL 34234

has been filed against you and you are required to serve a copy of your written defenses within 30 days after the first publication, if any, on Albertelli Law, Plaintiff's attorney, whose address is P.O. Box 23028, Tampa, FL 33623, and file the original with this Court either before 6-23-2014, service on Plaintiff's attorney, or immediately thereafter; otherwise, a default will be entered against you for the relief demanded in the Complaint or petition.

This notice shall be published once a week for two consecutive weeks in the Business Observer.

If you are a person with a disability who needs any accommodation in order to participate in this proceeding, you are entitled, at no cost to you, to the provision of certain assistance. Please contact the Sarasota County Jury Office, P.O. Box 3079, Sarasota, Florida 34230-3079, (941)861-7400, at least seven (7) days before your scheduled court appearance, or immediately upon receiving this notification if the time before the scheduled appearance is less than seven (7) days; if you are hearing or voice impaired, call 711.

WITNESS my hand and the seal of this court on this 12 day of May, 2014.

KAREN E. RUSHING, CLERK
Clerk of the Circuit Court
(SEAL) By: L. Szymanski
Deputy Clerk

Albertelli Law
P.O. Box 23028
Tampa, FL 33623
PH-13-119302
May 23, 30, 2014 14-02222S

FIRST INERTION

NOTICE OF ACTION
IN THE CIRCUIT COURT OF THE
TWELFTH JUDICIAL CIRCUIT
IN AND FOR SARASOTA COUNTY,
FLORIDA

CIVIL DIVISION
CASE NO.: 58-2013-CA-005835 NC
DIVISION: C

ONEWEST BANK, F.S.B.
Plaintiff, v.

LAURIE A. MANJUCK;
ALEXANDER G. MANJUCK, III;
ROBERT RANDALL; WILLIAM
RANDALL; UNITED STATES OF
AMERICA, ACTING ON BEHALF
OF THE SECRETARY OF
HOUSING AND URBAN
DEVELOPMENT; DISCOVER
BANK; UNKNOWN TENANT #1;
UNKNOWN TENANT #2; ALL
OTHER UNKNOWN PARTIES
CLAIMING INTERESTS BY,
THROUGH, UNDER, AND
AGAINST A NAMED
DEFENDANT(S) WHO ARE NOT
KNOWN TO BE DEAD OR ALIVE,
WHETHER SAME UNKNOWN
PARTIES MAY CLAIM AN
INTEREST AS SPOUSES, HEIRS,
DEVISEES, GRANTEEES, OR
OTHER CLAIMANTS,
Defendant(s),
TO: ROBERT RANDALL

Last Known Address: 637 Flamingo
Road
Venice, Florida 34293

Current Address: Unknown
Previous Address: Unknown
TO: WILLIAM RANDALL
Last Known Address: 637 Flamingo
Road
Venice, Florida 34293

Current Address: Unknown
Previous Address: Unknown
TO: ALL OTHER UNKNOWN PARTIES CLAIMING INTERESTS BY, THROUGH, UNDER, AND AGAINST A NAMED DEFENDANT(S) WHO ARE NOT KNOWN TO BE DEAD OR ALIVE, WHETHER SAME UNKNOWN PARTIES MAY CLAIM AN INTEREST AS SPOUSES, HEIRS, DEVISEES, GRANTEEES, OR OTHER CLAIMANTS

whose residence is unknown if he/she/they be living; and if he/she/they be dead, the unknown Defendants who may be spouses, heirs, devisees, grantees, assignees, lienors, creditors, trustees, and all parties claiming an interest by, through, under or against the Defendants, who are not known to be dead or alive, and all parties having or claiming to have any right, title or interest in the property described in the mortgage being foreclosed herein

NOTICE OF ACTION
IN THE CIRCUIT COURT OF THE
TWELFTH JUDICIAL CIRCUIT
IN AND FOR SARASOTA COUNTY,
FLORIDA

CIVIL ACTION
CASE NO.: 58-2014-CA-00762 NC
BANK OF NEW YORK MELLON
AS TRUSTEE CWMBS
2005-HYB10,
Plaintiff, vs.

JOSEPH E. MILES A/K/A JOSEPH
MILES, et al,
Defendant(s).

To:
JOSEPH E. MILES A/K/A JOSEPH
MILES

THE UNKNOWN SPOUSE OF JOSEPH E. MILES A/K/A JOSEPH MILES

Last Known Address: 1840 Ridgewood
Lane East
Glenview, FL 60025

Current Address: Unknown

ANY AND ALL UNKNOWN PARTIES CLAIMING BY, THROUGH, UNDER, AND AGAINST THE HEREIN NAMED INDIVIDUAL DEFENDANT(S) WHO ARE NOT KNOWN TO BE DEAD OR ALIVE, WHETHER SAID UNKNOWN PARTIES MAY CLAIM AN INTEREST AS SPOUSES, HEIRS, DEVISEES, GRANTEEES, OR OTHER CLAIMANTS

Last Known Address: Unknown
Current Address: Unknown

YOU ARE NOTIFIED that an action to foreclose a mortgage on the following property in Sarasota County, Florida:

UNIT 704-S, CRESCENT ARMS, A CONDOMINIUM, TOGETHER WITH AN UNDIVIDED INTEREST IN THE COMMON ELEMENTS APPURTENANT THERETO, ACCORDING TO THE DECLARATION OF CONDOMINIUM THEREOF, AS RECORDED IN OFFICIAL RECORDS

BOOK 735, AT PAGE 47, TOGETHER WITH THE PLAT THEREOF, RECORDED IN CONDOMINIUM BOOK 2, PAGES 39 & 39A, ALL OF THE PUBLIC RECORDS OF SARASOTA COUNTY, FLORIDA, TOGETHER WITH ANY AMENDMENTS THERETO.

A/K/A 6312 MIDNIGHT PASS ROAD, 704-S; SARASOTA, FL 34242

has been filed against you and you are required to serve a copy of your written defenses within 30 days after the first publication, if any, on Albertelli Law, Plaintiff's attorney, whose address is P.O. Box 23028, Tampa, FL 33623, and file the original with this Court either before 6-23-2014 service on Plaintiff's attorney, or immediately thereafter; otherwise, a default will be entered against you for the relief demanded in the Complaint or petition.

This notice shall be published once a week for two consecutive weeks in the Business Observer.

If you are a person with a disability who needs any accommodation in order to participate in this proceeding, you are entitled, at no cost to you, to the provision of certain assistance. Please contact the Sarasota County Jury Office, P.O. Box 3079, Sarasota, Florida 34230-3079, (941)861-7400, at least seven (7) days before your scheduled court appearance, or immediately upon receiving this notification if the time before the scheduled appearance is less than seven (7) days; if you are hearing or voice impaired, call 711.

WITNESS my hand and the seal of this court on this 12 day of May, 2014.

Clerk of the Circuit Court
(SEAL) By: G. Kopinsky
Deputy Clerk

Albertelli Law
P.O. Box 23028
Tampa, FL 33623
JR-13-113196
May 23, 30, 2014 14-02221S

FIRST INERTION

NOTICE OF ACTION
IN THE CIRCUIT COURT OF THE
TWELFTH JUDICIAL CIRCUIT OF
THE STATE OF FLORIDA, IN AND
FOR SARASOTA COUNTY
CIVIL DIVISION

CASE NO. 58-2012-CA-004383 NC
CITIMORTGAGE, INC.,
Plaintiff, vs.

LINDA BURCHFIELD ALSO
KNOWN AS LINDA SUE
BURCHFIELD, THE UNKNOWN
SPOUSE OF LINDA BURCHFIELD
ALSO KNOWN AS LINDA SUE
BURCHFIELD, CHRISTOPHER
BURCHFIELD, ANY AND ALL
UNKNOWN PARTIES CLAIMING
BY, THROUGH, UNDER, AND
AGAINST THE HEREIN NAMED
INDIVIDUAL DEFENDANT(S)
WHO ARE NOT KNOWN TO BE
DEAD OR ALIVE, WHETHER
SAID UNKNOWN PARTIES
MAY CLAIM AN INTEREST AS
SPOUSES, HEIRS, DEVISEES,
GRANTEEES OR OTHER
CLAIMANTS. TENANT # 1,
TENANT # 2, TENANT # 3 AND
TENANT # 4
Defendant(s).

TO: LINDA BURCHFIELD A/K/A LINDA SUE BURCHFIELD; UNKNOWN SPOUSE OF LINDA BURCHFIELD A/K/A LINDA SUE BURCHFIELD

Whose residence(s) is/are unknown.

YOU ARE HEREBY required to file your answer or written defenses, if any, in the above proceeding with the Clerk of this Court, and to serve a copy thereof upon the plaintiff's attorney, Law Offices of Daniel C. Consuegra, 9204 King Palm Drive, Tampa, FL 33619-1328, telephone (813) 915-8660, facsimile (813) 915-0559, within thirty days of the first publication of this Notice, the nature of this proceeding being a suit for foreclosure of mortgage against the following described property, to

wit:

Lot 8, PERRY LANE SUBDIVISION, according to the plat thereof, as recorded in Plat Book 28, Page 8, of the Public Records of Sarasota County, Florida.

If you fail to file your response or answer, if any, in the above proceeding with the Clerk of this Court, and to serve a copy thereof upon the plaintiff's attorney, Law Offices of Daniel C. Consuegra, 9204 King Palm Drive, Tampa, Florida 33619-1328, telephone (813) 915-8660, facsimile (813) 915-0559, within thirty days of the first publication of this Notice, a default will be entered against you for the relief demanded in the Complaint or petition.

If you are a person with a disability who needs any accommodation in order to participate in this proceeding, you are entitled, at no cost to you, to the provision of certain assistance. Please contact the Sarasota County Jury Office, P.O. Box 3079, Sarasota, Florida 34230-3079, (941)861-7400, at least seven (7) days before your scheduled court appearance, or immediately upon receiving this notification if the time before the scheduled appearance is less than seven (7) days; if you are hearing or voice impaired, call 711.

DATED AT SARASOTA County this 12th day of May, 2014.

KAREN E. RUSHING, CLERK
Clerk of the Circuit Court
(SEAL) By: L. Szymanski
Deputy Clerk

Law Offices of
Daniel C. Consuegra
9204 King Palm Drive
Tampa, FL 33619-1328
telephone (813) 915-8660
facsimile (813) 915-0559
File No. 153037-T/Seterus, Inc./
Burchfield, Christopher & Linda/lpd
May 23, 30, 2014 14-02228S

YOU ARE NOTIFIED that an action to foreclose a mortgage on the following property in Sarasota County, Florida: LOTS 770 & 771 SOUTH VENICE, UNIT NO. 3, ACCORDING TO THE PLAT THEREOF RECORDED IN PLAT BOOK 6, PAGE 31, OF THE PUBLIC RECORDS OF SARASOTA COUNTY, FLORIDA.

This property is located at the Street address of: 637 Flamingo Road, Venice, Florida 34293

YOU ARE REQUIRED to serve a copy of your written defenses on or before June 23, 2014 a date which is within 30 days after the first publication, if any, on Elizabeth R. Wellborn, P.A., Plaintiff's Attorney, whose address is 350 Jim Moran Blvd., Suite 100, Deerfield Beach, Florida 33442, and file the original with this Court either before service on Plaintiff's Attorney, or immediately thereafter; otherwise, a default will be entered against you for the relief demanded in the Complaint or Petition.

This Notice shall be published once a week for two consecutive weeks in the Business Observer.

If you are a person with a disability who needs any accommodation in order to participate in this

proceeding, you are entitled, at no cost to you, to the provision of certain assistance. Please contact the Sarasota County Jury Office, P.O. Box 3079, Sarasota, Florida 34230-3079, (941)861-7400, at least seven (7) days before your scheduled court appearance, or immediately upon receiving this notification if the time before the scheduled appearance is less than seven (7) days; if you are hearing or voice impaired, call 711.

WITNESS my hand and the seal of the court on May 8, 2014.

KAREN E. RUSHING
CLERK OF THE COURT
(COURT SEAL) By: C. Brandenburg
Deputy Clerk

Attorney for Plaintiff:
Jacqueline Gardiner, Esq.
Arlisa Certain, Esq.
Elizabeth R. Wellborn, P.A.
350 Jim Moran Blvd.,
Suite 100
Deerfield Beach, FL 33442
Telephone: (954) 354-3544
Facsimile: (954) 354-3545
Primary email:
jgardiner@erlaw.com
Secondary email:
servicecomplete@erlaw.com
2012-15782
May 23, 30, 2014 14-02239S

FIRST INERTION

NOTICE OF ACTION
IN THE CIRCUIT COURT OF THE
TWELFTH JUDICIAL CIRCUIT
IN AND FOR SARASOTA COUNTY,
FLORIDA

CIVIL ACTION
CASE NO.: 58-2013-CA-004671-NC
DIVISION: A

NATIONSTAR MORTGAGE LLC,
Plaintiff, vs.
JOSEPH R. MERCIER, et al,
Defendant(s).

TO:

THE UNKNOWN BENEFICIARY OF THE WILHELMINA L. MERCIER REVOCABLE TRUST UNDER TRUST AGREEMENT DATED MARCH 29, 1991 A/K/A THE WILHELMINA L. MERCIER LIVING TRUST DATED MARCH 29, 1991

LAST KNOWN ADDRESS: UNKNOWN

CURRENT ADDRESS: UNKNOWN

THE UNKNOWN HEIRS, DEVISEES, GRANTEEES, ASSIGNEES, LIENORS, CREDITORS, TRUSTEES, OR OTHER CLAIMANTS CLAIMING BY, THROUGH, UNDER, OR AGAINST WILHELMINA L. MERCIER A/K/A WILHELMINA LOUISE MERCIER, DECEASED

LAST KNOWN ADDRESS: UNKNOWN

CURRENT ADDRESS: UNKNOWN

ANY AND ALL UNKNOWN PARTIES CLAIMING BY, THROUGH, UNDER, AND AGAINST THE HEREIN NAMED INDIVIDUAL DEFENDANT(S) WHO ARE NOT KNOWN TO BE DEAD OR ALIVE, WHETHER SAID UNKNOWN PARTIES MAY CLAIM AN INTEREST AS SPOUSES, HEIRS, DEVISEES, GRANTEEES, OR OTHER CLAIMANTS

LAST KNOWN ADDRESS: UNKNOWN

CURRENT ADDRESS: UNKNOWN

YOU ARE NOTIFIED that an action to foreclose a mortgage on the following property in SARASOTA County, Florida:

UNIT 28, SAINT GEORGE AT THE PLANTATION, A CONDOMINIUM ACCORDING TO THE DECLARATION OF CONDOMINIUM RECORDED IN OFFICIAL RECORDS BOOK 1862, PAGE 1726, AND

AS AMENDED, AND AS PER THE PLAT THEREOF RECORDED IN CONDOMINIUM BOOK 25, PAGE 43, OF THE PUBLIC RECORDS OF SARASOTA COUNTY, FLORIDA.

TOGETHER WITH AN UNDIVIDED INTEREST IN THE COMMON ELEMENTS APPURTENANT THERETO AS SET FORTH IN SAID DECLARATION

has been filed against you and you are required to serve a copy of your written defenses within 30 days after the first publication, if any, on Ronald R Wolfe & Associates, P.L., Plaintiff's attorney, whose address is 4919 Memorial Highway, Suite 200, Tampa, Florida 33634, and file the original with this Court either before service on Plaintiff's attorney or immediately thereafter; otherwise a default will be entered against you for the relief demanded in the Complaint or petition.

This notice shall be published once each week for two consecutive weeks in the Business Observer.

If you are a person with a disability who needs any accommodation in order to participate in this proceeding, you are entitled, at no cost to you, to the provision of certain assistance. Please contact the Sarasota County Jury Office, P.O. Box 3079, Sarasota, Florida 34230-3079, (941)861-7400, at least seven (7) days before your scheduled court appearance, or immediately upon receiving this notification if the time before the scheduled appearance is less than seven (7) days; if you are hearing or voice impaired, call 711.

WITNESS my hand and the seal of this Court on this 14 day of May, 2014.

KAREN E. RUSHING
Clerk of the Court
(SEAL) By: L. Szymanski
As Deputy Clerk

Ronald R Wolfe & Associates, P.L.,
Plaintiff's Attorney,
P.O. Box 25018
Tampa, Florida 33622-5018
F13003935
May 23, 30, 2014 14-02240S

SUBSEQUENT INSERTIONS

SECOND INSERTION

NOTICE OF PUBLIC SALE

Notice is hereby given that Hide Away Storage Services, LLC will sell the items below at a public auction to the highest bidder to be held at 8901; S. Tamiami Trail Sarasota, FL 34238 on Tuesday, June 10, 2014 at 9:00 AM.

Personal belongings for:

Mark Rowe-00869-Household Goods, Boxes, Plastic Bins
Dixey Behnken-00961-Household Goods, Toys, Boxes, Plastic Bins
Christopher Mcmillen-00827-Household Goods, Boxes, Bike
James Mcbride-00310-Plastic Bins, Luggage.
Tari Davis-00756-Household Goods, Boxes, Tools, Plastic Bins
Mitch Geoffroy-00647-Household Goods, Boxes, Toys, Grill
Wolfgang Fuerniss-M0168-Household Goods, Boxes
Wolfgang Fuerniss-M0066-Household Goods, Boxes
Wolfgang Fuerniss-M0167-Household Goods, Boxes
Wolfgang Fuerniss-M0169-Household Goods, Boxes
Wolfgang Fuerniss-M0170-Household Goods, Boxes
Chris Yent-00677-Household Goods, Tools, Boxes
Chris Yent-00806-Household Goods, Boxes, Tools
Chris Yent-00826-Household Goods, Boxes
Chris Yent-00957-Boxes
Chris Yent-00958-Boxes, Clothes
Chris Yent-00959-Household Goods, Boxes

Notice is hereby given that Hide Away Storage Services, LLC will sell the items below at a public auction to the highest bidder to be held at 335 South Beneva Road; Sarasota, FL 34232 on Tuesday, June 10, 2014 at 10:30 AM.

Personal Belonging For:

Ernesto Acosta-00925-Household goods, boxes, plastic bins
Teresa Addison-01219-Household goods, plastic bins
Jack Azbell Jr.-01266-Tools, boxes, grill, toys
Laura Bolte-00346-Household goods, boxes, tools, guitars
Luis Elorrea-01019-Household goods
Anthony L. Freu-00826-Household goods, plastic bins
Erica Guerrero-01245-Boxes, household goods, toys
Christian Giblin-00739-Household goods, boxes, tools, toys
Christian Giblin-01055-Household goods, boxes
Charles Hall-01438-Household goods, boxes, plastic bins, files cab.
Charles Hall-01439-Boxes, household goods, tools, clothes
Jeff Halpin-01246-Household goods, toy
Sheridan Kortright-01064-Household goods, boxes
Amy Mohr-01042-Toys, clothes

Ralph Ridenour-01232-Household goods, toys, plastic bags, fishing poles
Notice is hereby given that Xpress Storage; Fruitville Road, LLC will sell the items below at a public auction to the highest bidder to be held at 7600 Claxtrauss Drive; Sarasota, FL 34240 on Tuesday, June 10, 2014 at 12:00 PM.

Personal Belongings For:

2103-Roxanne Fabrizio-Boxes, Computers, Plastic Bags, Luggage
Notice is hereby given that Hide Away Storage Services, LLC will sell the items below at a public auction to the highest bidder to be held at 2590 17th Street; Sarasota, FL 34234 on Tuesday, June 10, 2014 at 12:30 PM.

Personal belongings for:

00143-Chad Johnson-Boxes, plastic bins
00257-Gloria Filsaime-Boxes, plastic bags
00371-Adecia Johnson-Boxes, plastic bins, plastic bags
00420-Terry Larson-Boxes, plastic bins, household goods
00447-Travis Richardson-Household goods, boxes, plastic bins
01002-Kerlister Davis-Household goods, plastic bins
01012-Ayesha Hill-Household goods, tires
01016-Jenny Aleman-A/C unit, boxes
01025-Mirna Carrillo-Household goods, plastic bin
01132-Valado Wilcox-Household goods, boxes
01135-Stephanie Southworth-Boxes, household goods
01140-Joseph Hunter-Household goods, plastic bins
01179-Jason Wentz-Household goods, plastic bins, tools
01195-Debra Livingston-Boxes, shelving
01322-Mallory Kirkland-Household goods, washer & dryer
01333-Reginald Scurry-Household goods, boxes, safe, tools
M0115-Lori-Anne Fay-Bags of books, file cabinet, plastic bins
M0053-Faye Gibbons Turner-Clothes bins
M0059-Faye Gibbons Turner-Clothes bins

May 16, 23, 2014

14-02120S

SECOND INSERTION

NOTICE OF PUBLIC SALE OF PERSONAL PROPERTY
 Notice is hereby given that the undersigned will sell, to satisfy lien of the owner, at public sale by competitive bidding on 06/05/2014 at 3:00 PM at the Extra Space Storage facility located at:
 2251 N. Washington Blvd Sarasota, FL 34234 Tel 941-954-3730 e-fax 941-296-8989
 The personal goods stored therein by the following may include, but are not limited to general household, furniture, boxes, clothes, and appliances.
 M002 Eric Fletcher- Vehicle, M006 Rodney Moreland- Vehicle, A214 Elizabeth Cooper- Personal Items, A046 Brandi Molasso- Personal Items, A049 Kevin Burns- Personal Items, A511 Cynthia Hughes- Boxes, A009 Jaucita Brown- Boxes, F025 Kimberly Wheeler-Personal Items, D014 Tocara Wilcox- Furniture, A603 Martha Bookins- Personal Items, A017 Willie V Washington- Personal Items, A604 Krista Bowley-Personal Items.
 Purchases must be made with cash only and paid at the time of sale. All goods are sold as is and must be removed at the time of purchase. Extra Space Storage reserves the right to refuse any bid. Sale is subject to adjournment.
 May 16, 23, 2014 14-02138S

SECOND INSERTION

NOTICE OF PUBLIC SALE OF PERSONAL PROPERTY METRO SELF STORAGE
 Notice is hereby given that the undersigned self storage unit(s) will be sold at a public sale by competitive bidding, in their entirety to the highest bidder, on or after date and time below to satisfy the lien of Metro Self Storage for rental and other charges due from the undersigned. The said property has been stored and generally described below is located at the respective address. The sale will begin at the date and time below on or after on said date and will continue hour by hour until all units are sold. Auctioneer Lic# AU4167 and AB2825, 10% Buyers Premium.
 Tuesday June 3rd 2014
 10:00 AM
 619 Cattlemen Rd
 Sarasota, FL 34232
 J24 Robyn Barnes
 S93 Chris Smith
 C5 James Anzalone, American Security and Access Consultants, American Security and Access Corp
 A3 Adam Delerico, Adam Declerico
 T12 Lori Mudge
 The contents consist of general, household and miscellaneous items. The terms of the sale will be cash only and must be paid for at the time of the sale. All goods are sold as is. Metro Self Storage reserves the right to withdraw any or all units for the sale at any time. All contents must be removed within 48 hours or sooner.
 May 16, 23, 2014 14-02121S

SECOND INSERTION

NOTICE OF SHERIFF'S SALE
 NOTICE is hereby given that pursuant to a Writ of Execution issued in the Circuit Court of Sarasota County, Florida, on the 1st day of April, 2014, in the cause wherein Joan Engelbach, Plaintiff, and James A. Graham and Doiana I. Graham, et al, Defendants, being case number 12CA4258NC, in said Court, I, Thomas M. Knight, as Sheriff of Sarasota County, Florida, have levied upon all the right, title and interest of the Defendants, James A. Graham and Doiana I. Graham, in and to the following described real properties, to-wit:
 Lot 3, Block D, EDGEWATER, as per plat or map thereof Recorded in Plat Book 1, Page 160 of the Public Records of Sarasota County, Florida.
 Street Address: 2023 Coconut Avenue, Sarasota, FL 34234

Lot 22, Block C, NEWTOWN HEIGHTS, as per plat or map thereof Recorded in Plat Book 1, Page 199 of the Public Records of Sarasota County, Florida.
 Street Address: 2913 Church Ave., Sarasota, FL 34234
 I shall offer these properties for sale at 2071 Ringling Blvd Sarasota, FL 34237, County of Sarasota, Florida, on June 16, 2014, at the hour of 1:00 p.m., or as soon thereafter as possible. I will offer for sale all of the said Defendant's, James A. Graham and Doiana I. Graham, right, title, and interest in the aforesaid real properties, at public auction and will sell the same, subject to taxes, all prior liens, encumbrances and judgments, if any, to the highest and best bidder for CASH IN HAND. The moneys received through the levy on sale will be paid as prescribed by F.S.S. 56.27 and in accordance with the American Disabilities Act, persons needing a special accommodation to participate in this proceeding shall contact the individual or agency sending notice not later than seven days prior to the proceeding at the address given on notice. Telephone 941-861-4110.
 Thomas M. Knight, As Sheriff of Sarasota County, Florida
 By: Sgt. R. Beasley #476
 May 16, 23, 30; June 6, 2014
 14-02175S

FOURTH INSERTION

NOTICE OF APPLICATION FOR TAX DEED
 Notice is hereby given that KIRK TRENCHFIELD & PURIS ENVIRONMENTAL INC, the holder of the certificate listed below, has filed said certificate for a tax deed to be issued. The certificate number and year of issuance, the description of the property, and the names in which the property is assessed are as follows:
 Certificate Number: 10669.000
 Year of Issuance: 2012
 Tax Deed File #: 14-0029 TD
 Description of Property: 1148199321 TRACT ZZ CONTAINING 1.85 AC M/L 44TH ADD TO PORT CHARLOTTE
 Name in which the property is assessed: CHARLOTTE SARASOTA HOLDINGS LL
 All of said property being in the County of Sarasota, State of Florida. Unless the certificate is redeemed according to law, the property described in the certificate will be sold to the highest bidder at the Sarasota County Court House, 2000 Main Street, Historic Courtroom, East Wing, Sarasota, Florida, at 9:00 a.m. on the 3RD day of JUNE, 2014.
 Karen E. Rushing
 Clerk Of The Circuit Court
 Sarasota County, Florida
 By: T. Lake, Deputy Clerk
 Publication Dates: MAY 2, 9, 16, 23 2014
 14-01876S

SECOND INSERTION

NOTICE OF APPLICATION FOR TAX DEED
 Notice is hereby given that LAWRENCE LEVICK FAM TRUST, the holder of the certificate listed below, has filed said certificate for a tax deed to be issued. The certificate number and year of issuance, the description of the property, and the names in which the property is assessed are as follows:
 Certificate Number: 2069.000
 Year of Issuance: 2012
 Tax Deed File #: 14-0107 TD
 Description of Property: 0169164175 UNIT S-33, GULF HARBOR MARINA
 Name in which the property is assessed: AFRAM S KALLAH & ANDREA M KALLAH
 All of said property being in the County of Sarasota, State of Florida. Unless the certificate is redeemed according to law, the property described in the certificate will be sold to the highest bidder at the Sarasota County Court House, 2000 Main Street, Historic Courtroom, East Wing, Sarasota, Florida, at 9:00 a.m. on the 17TH day of JUNE, 2014.
 Karen E. Rushing
 Clerk Of The Circuit Court
 Sarasota County, Florida
 By: T. Lake, Deputy Clerk
 Publication Dates: MAY 16, 23, 30; JUNE 6, 2014
 14-02200S

SECOND INSERTION

NOTICE OF APPLICATION FOR TAX DEED
 Notice is hereby given that LAWRENCE LEVICK FAM TRUST, the holder of the certificate listed below, has filed said certificate for a tax deed to be issued. The certificate number and year of issuance, the description of the property, and the names in which the property is assessed are as follows:
 Certificate Number: 6144.000
 Year of Issuance: 2012
 Tax Deed File #: 14-0103 TD
 Description of Property: 0967060420 LOTS 20 21 & 22 BLK 604 18TH ADD TO PORT CHARLOTTE
 Name in which the property is assessed: ALBERT A DOW EST
 All of said property being in the County of Sarasota, State of Florida. Unless the certificate is redeemed according to law, the property described in the certificate will be sold to the highest bidder at the Sarasota County Court House, 2000 Main Street, Historic Courtroom, East Wing, Sarasota, Florida, at 9:00 a.m. on the 17TH day of JUNE, 2014.
 Karen E. Rushing
 Clerk Of The Circuit Court
 Sarasota County, Florida
 By: T. Lake, Deputy Clerk
 Publication Dates: MAY 16, 23, 30; JUNE 6, 2014
 14-02197S

SECOND INSERTION

NOTICE OF PUBLIC SALE
 In accordance with Florida State Law Self Storage Facility Act 83.801-83.809, ss.4(a) and to satisfy an operator's lien, the contents of the following units will be sold at a public auction to the highest bidder for cash on or thereafter:
 Date: June 5, 2014
 Time: 4:00 p.m., or after
 At: Patriot Self Storage, 6029 Talon Bay Drive, North Port, FL 34287
 Unit #2012 - Joshua Tyler Cullen, Household and personal.
 Unit #4610 - Eleanor Rose Pellegrino, Household and personal.
 Unit #4400 - Eleanor Rose Pellegrino, Household and personal.
 Patriot Self Storage reserves the right to cancel the sale at any time for any reason.
 May 16, 23, 2014 14-02177S

SECOND INSERTION

NOTICE OF PUBLIC SALE OF PERSONAL PROPERTY
 Notice is hereby given that the undersigned will sell, to satisfy lien of the owner, at public sale by Competitive bidding on 06-05-2014 at 9:30 am at the Extra Space Storage facility located at:
 4173 Clark Road Sarasota, FL 34233 941-925-4006
 The personal goods stored therein by the following may include, but are not limited to general household, furniture, boxes, clothes, and appliances.
 584 Beverly Deitrich -Furniture, Household Items, 274 Clarke Dennis-Tools, Machineries, 63 Holly Wyman-Furniture, 468 Jeffrey Marten -Boxes, Furniture, 492 Paul D Woods-Furniture
 Purchases must be made with cash only and paid at the time of sale. All goods are sold as is and must be removed at the time of purchase. Extra Space Storage reserves the right to bid. Sale is subject to adjournment.
 May 16, 23, 2014 14-02159S

SECOND INSERTION

NOTICE OF PUBLIC SALE
 In accordance with Florida State Law Self Storage Facility Act 83.801-83.809, ss.4(a) and to satisfy an operator's lien, the contents of the following units will be sold at a public auction to the highest bidder for cash on or thereafter:
 Date: June 5, 2014
 Time: 3:00 p.m., or after
 At: Patriot Self Storage, 2245 Bobcat Village Center Rd., North Port, FL 34288
 Unit#3130 - Courtney A. Zappasodi, household and personal.
 Patriot Self Storage reserves the right to cancel the sale at any time for any reason.
 May 16, 23, 2014 14-02176S

SECOND INSERTION

NOTICE OF APPLICATION FOR TAX DEED
 Notice is hereby given that CITRUS CAPITAL LLC - SERIES 44 US BANK % CITRUS CAPITAL LLC, the holder of the certificate listed below, has filed said certificate for a tax deed to be issued. The certificate number and year of issuance, the description of the property, and the names in which the property is assessed are as follows:
 Certificate Number: 3757.000
 Year of Issuance: 2012
 Tax Deed File #: 14-0046 TD
 Description of Property: 0496060057 W 1/2 OF N 1/2 OF SW 1/4 LOT 44 BEING W 1/2 OF LOT 12 UNREC PLAT OF LOT 44 PLAT OF ENGLEWOOD
 Name in which the property is assessed: GERALDINE MARCHAND
 All of said property being in the County of Sarasota, State of Florida. Unless the certificate is redeemed according to law, the property described in the certificate will be sold to the highest bidder at the Sarasota County Court House, 2000 Main Street, Historic Courtroom, East Wing, Sarasota, Florida, at 9:00 a.m. on the 17TH day of JUNE, 2014.
 Karen E. Rushing
 Clerk Of The Circuit Court
 Sarasota County, Florida
 By: T. Lake, Deputy Clerk
 Publication Dates: MAY 16, 23, 30; JUNE 6, 2014
 14-02193S

SECOND INSERTION

NOTICE OF APPLICATION FOR TAX DEED
 Notice is hereby given that LAWRENCE LEVICK FAM TRUST, the holder of the certificate listed below, has filed said certificate for a tax deed to be issued. The certificate number and year of issuance, the description of the property, and the names in which the property is assessed are as follows:
 Certificate Number: 3899.000
 Year of Issuance: 2012
 Tax Deed File #: 14-0047 TD
 Description of Property: 0591031770 LOT 177 LESS PORTION DESC AS, BEG AT MOST ELY COR OF SAID LOT 177, SAID COR BEING ON C/L OF ROCKING HORSE LN, TH S-53-34-01-W 419.14 FT TH N-28-19-02-W 161.62 FT TH N-53-43-01-E 396.32 FT TH S-36-25-59-E 160 FT TO POB, MYAKKA VALLEY RANCHES UNIT 4, CONTAINING 5 C-AC/M/L
 Name in which the property is assessed: ALLIE M MULLINIX
 All of said property being in the County of Sarasota, State of Florida. Unless the certificate is redeemed according to law, the property described in the certificate will be sold to the highest bidder at the Sarasota County Court House, 2000 Main Street, Historic Courtroom, East Wing, Sarasota, Florida, at 9:00 a.m. on the 17TH day of JUNE, 2014.
 Karen E. Rushing
 Clerk Of The Circuit Court
 Sarasota County, Florida
 By: T. Lake, Deputy Clerk
 Publication Dates: MAY 16, 23, 30; JUNE 6, 2014
 14-02194S

SECOND INSERTION

NOTICE OF APPLICATION FOR TAX DEED
 Notice is hereby given that CITRUS CAPITAL LLC - SERIES 44 US BANK % CITRUS CAPITAL LLC, the holder of the certificate listed below, has filed said certificate for a tax deed to be issued. The certificate number and year of issuance, the description of the property, and the names in which the property is assessed are as follows:
 Certificate Number: 7943.000
 Year of Issuance: 2012
 Tax Deed File #: 14-0049 TD
 Description of Property: 1007252613 LOT 13 BLK 2526 51ST ADD TO PORT CHARLOTTE
 Name in which the property is assessed: WILLIAM ERICKSON
 All of said property being in the County of Sarasota, State of Florida. Unless the certificate is redeemed according to law, the property described in the certificate will be sold to the highest bidder at the Sarasota County Court House, 2000 Main Street, Historic Courtroom, East Wing, Sarasota, Florida, at 9:00 a.m. on the 17TH day of JUNE, 2014.
 Karen E. Rushing
 Clerk Of The Circuit Court
 Sarasota County, Florida
 By: T. Lake, Deputy Clerk
 Publication Dates: MAY 16, 23, 30; JUNE 6, 2014
 14-02196S

SECOND INSERTION

NOTICE OF APPLICATION FOR TAX DEED
 Notice is hereby given that CITRUS CAPITAL LLC - SERIES 44 US BANK % CITRUS CAPITAL LLC, the holder of the certificate listed below, has filed said certificate for a tax deed to be issued. The certificate number and year of issuance, the description of the property, and the names in which the property is assessed are as follows:
 Certificate Number: 3311.000
 Year of Issuance: 2012
 Tax Deed File #: 14-0045 TD
 Description of Property: 0461010002 LOT 75 VENETIA PHASE 4
 Name in which the property is assessed: PAULA OREILLY & JOHN OREILLY
 All of said property being in the County of Sarasota, State of Florida. Unless the certificate is redeemed according to law, the property described in the certificate will be sold to the highest bidder at the Sarasota County Court House, 2000 Main Street, Historic Courtroom, East Wing, Sarasota, Florida, at 9:00 a.m. on the 17TH day of JUNE, 2014.
 Karen E. Rushing
 Clerk Of The Circuit Court
 Sarasota County, Florida
 By: T. Lake, Deputy Clerk
 Publication Dates: MAY 16, 23, 30; JUNE 6, 2014
 14-02192S

SECOND INSERTION

NOTICE OF SHERIFF'S SALE
 NOTICE is hereby given that pursuant to a Writ of Execution issued in the County Court of Sarasota County, Florida, on the 4th day of March, 2014, in the cause wherein CACH, LLC, Plaintiff, and Barbara M. Mayo, Defendant, being case number 13SC5769SC, in said Court, I, Thomas M. Knight, as Sheriff of Sarasota County, Florida, have levied upon all the right, title and interest of the Defendant, Barbara M. Mayo, in and to the following described personal property, to-wit:
 2005 GM SIERRA 1500
 VIN: 2GTEC13TX51189678
 I shall offer this property for sale at 2071 Ringling Blvd Sarasota, FL 34237, County of Sarasota, Florida, on June 17, 2014, at the hour of 1:00 p.m., or as soon thereafter as possible. I will offer for sale all of the said Defendant's, Barbara M. Mayo, right, title, and interest in the aforesaid personal property, at public auction and will sell the same, subject to taxes, all prior liens, encumbrances and judgments, if any, to the highest and best bidder for CASH IN HAND. The moneys received through the levy on sale will be paid as prescribed by F.S.S. 56.27, and in accordance with the American Disabilities Act, persons needing a special accommodation to participate in this proceeding shall contact the individual or agency sending notice not later than seven days prior to the proceeding at the address given on notice. Telephone 941-861-4110. Vehicle may be viewed the same day of the sale between the hours of 11:30 am & 12:30 pm at Upman's Towing 2175 12th St. Sarasota, FL 34236.
 Thomas M. Knight, Sheriff
 Sarasota County, Florida
 By: Sgt. R. Beasley #476
 May 16, 23 & 30; June 6, 2014
 14-02158S

SECOND INSERTION

NOTICE OF APPLICATION FOR TAX DEED
 Notice is hereby given that CITRUS CAPITAL LLC - SERIES 44 US BANK % CITRUS CAPITAL LLC, the holder of the certificate listed below, has filed said certificate for a tax deed to be issued. The certificate number and year of issuance, the description of the property, and the names in which the property is assessed are as follows:
 Certificate Number: 10279.000
 Year of Issuance: 2012
 Tax Deed File #: 14-0028 TD
 Description of Property: 1144072026 LOT 26 BLK 720 12TH ADD TO PORT CHARLOTTE
 Name in which the property is assessed: DENNIS HANNAK
 All of said property being in the County of Sarasota, State of Florida. Unless the certificate is redeemed according to law, the property described in the certificate will be sold to the highest bidder at the Sarasota County Court House, 2000 Main Street, Historic Courtroom, East Wing, Sarasota, Florida, at 9:00 a.m. on the 3RD day of JUNE, 2014.
 Karen E. Rushing
 Clerk Of The Circuit Court
 Sarasota County, Florida
 By: T. Lake, Deputy Clerk
 Publication Dates: MAY 2, 9, 16, 23 2014
 14-01875S

SECOND INSERTION

NOTICE OF APPLICATION FOR TAX DEED
 Notice is hereby given that CITRUS CAPITAL LLC - SERIES 44 US BANK % CITRUS CAPITAL LLC, the holder of the certificate listed below, has filed said certificate for a tax deed to be issued. The certificate number and year of issuance, the description of the property, and the names in which the property is assessed are as follows:
 Certificate Number: 7943.000
 Year of Issuance: 2012
 Tax Deed File #: 14-0049 TD
 Description of Property: 1007252613 LOT 13 BLK 2526 51ST ADD TO PORT CHARLOTTE
 Name in which the property is assessed: WILLIAM ERICKSON
 All of said property being in the County of Sarasota, State of Florida. Unless the certificate is redeemed according to law, the property described in the certificate will be sold to the highest bidder at the Sarasota County Court House, 2000 Main Street, Historic Courtroom, East Wing, Sarasota, Florida, at 9:00 a.m. on the 17TH day of JUNE, 2014.
 Karen E. Rushing
 Clerk Of The Circuit Court
 Sarasota County, Florida
 By: T. Lake, Deputy Clerk
 Publication Dates: MAY 16, 23, 30; JUNE 6, 2014
 14-02196S

SECOND INSERTION

NOTICE OF APPLICATION FOR TAX DEED
 Notice is hereby given that CITRUS CAPITAL LLC - SERIES 44 US BANK % CITRUS CAPITAL LLC, the holder of the certificate listed below, has filed said certificate for a tax deed to be issued. The certificate number and year of issuance, the description of the property, and the names in which the property is assessed are as follows:
 Certificate Number: 7943.000
 Year of Issuance: 2012
 Tax Deed File #: 14-0049 TD
 Description of Property: 1007252613 LOT 13 BLK 2526 51ST ADD TO PORT CHARLOTTE
 Name in which the property is assessed: WILLIAM ERICKSON
 All of said property being in the County of Sarasota, State of Florida. Unless the certificate is redeemed according to law, the property described in the certificate will be sold to the highest bidder at the Sarasota County Court House, 2000 Main Street, Historic Courtroom, East Wing, Sarasota, Florida, at 9:00 a.m. on the 17TH day of JUNE, 2014.
 Karen E. Rushing
 Clerk Of The Circuit Court
 Sarasota County, Florida
 By: T. Lake, Deputy Clerk
 Publication Dates: MAY 16, 23, 30; JUNE 6, 2014
 14-02196S

SECOND INSERTION

NOTICE OF APPLICATION FOR TAX DEED
 Notice is hereby given that CITRUS CAPITAL LLC - SERIES 44 US BANK % CITRUS CAPITAL LLC, the holder of the certificate listed below, has filed said certificate for a tax deed to be issued. The certificate number and year of issuance, the description of the property, and the names in which the property is assessed are as follows:
 Certificate Number: 3069.000
 Year of Issuance: 2012
 Tax Deed File #: 14-0044 TD
 Description of Property: 0436110026 LOTS 15894 & 15895 SOUTH VENICE UNIT 60
 Name in which the property is assessed: JO-ANN SUMMERVILLE & SHELDON SUMMERVILLE
 All of said property being in the County of Sarasota, State of Florida. Unless the certificate is redeemed according to law, the property described in the certificate will be sold to the highest bidder at the Sarasota County Court House, 2000 Main Street, Historic Courtroom, East Wing, Sarasota, Florida, at 9:00 a.m. on the 17TH day of JUNE, 2014.
 Karen E. Rushing
 Clerk Of The Circuit Court
 Sarasota County, Florida
 By: T. Lake, Deputy Clerk
 Publication Dates: MAY 16, 23, 30; JUNE 6, 2014
 14-02191S

SECOND INSERTION

NOTICE OF APPLICATION FOR TAX DEED
 Notice is hereby given that CITRUS CAPITAL LLC - SERIES 44 US BANK % CITRUS CAPITAL LLC, the holder of the certificate listed below, has filed said certificate for a tax deed to be issued. The certificate number and year of issuance, the description of the property, and the names in which the property is assessed are as follows:
 Certificate Number: 3069.000
 Year of Issuance: 2012
 Tax Deed File #: 14-0044 TD
 Description of Property: 0436110026 LOTS 15894 & 15895 SOUTH VENICE UNIT 60
 Name in which the property is assessed: JO-ANN SUMMERVILLE & SHELDON SUMMERVILLE
 All of said property being in the County of Sarasota, State of Florida. Unless the certificate is redeemed according to law, the property described in the certificate will be sold to the highest bidder at the Sarasota County Court House, 2000 Main Street, Historic Courtroom, East Wing, Sarasota, Florida, at 9:00 a.m. on the 17TH day of JUNE, 2014.
 Karen E. Rushing
 Clerk Of The Circuit Court
 Sarasota County, Florida
 By: T. Lake, Deputy Clerk
 Publication Dates: MAY 16, 23, 30; JUNE 6, 2014
 14-02191S

FOURTH INSERTION

NOTICE OF APPLICATION FOR TAX DEED
 Notice is hereby given that KIRK TRENCHFIELD & PURIS ENVIRONMENTAL INC, the holder of the certificate listed below, has filed said certificate for a tax deed to be issued. The certificate number and year of issuance, the description of the property, and the names in which the property is assessed are as follows:
 Certificate Number: 4734.000
 Year of Issuance: 2012
 Tax Deed File #: 14-0031 TD
 Description of Property: 0947010308 LOT 8 BLK 3 NORTH PORT CHARLOTTE ESTATES
 Name in which the property is assessed: CHARLES VAN SICKLE & ELIZABETH M WILLIAMS
 All of said property being in the County of Sarasota, State of Florida. Unless the certificate is redeemed according to law, the property described in the certificate will be sold to the highest bidder at the Sarasota County Court House, 2000 Main Street, Historic Courtroom, East Wing, Sarasota, Florida, at 9:00 a.m. on the 3RD day of JUNE, 2014.
 Karen E. Rushing
 Clerk Of The Circuit Court
 Sarasota County, Florida
 By: T. Lake, Deputy Clerk
 Publication Dates: MAY 2, 9, 16, 23 2014
 14-01878S

FOURTH INSERTION

NOTICE OF APPLICATION FOR TAX DEED
 Notice is hereby given that KIRK TRENCHFIELD & PURIS ENVIRONMENTAL INC, the holder of the certificate listed below, has filed said certificate for a tax deed to be issued. The certificate number and year of issuance, the description of the property, and the names in which the property is assessed are as follows:
 Certificate Number: 4734.000
 Year of Issuance: 2012
 Tax Deed File #: 14-0031 TD
 Description of Property: 0947010308 LOT 8 BLK 3 NORTH PORT CHARLOTTE ESTATES
 Name in which the property is assessed: CHARLES VAN SICKLE & ELIZABETH M WILLIAMS
 All of said property being in the County of Sarasota, State of Florida. Unless the certificate is redeemed according to law, the property described in the certificate will be sold to the highest bidder at the Sarasota County Court House, 2000 Main Street, Historic Courtroom, East Wing, Sarasota, Florida, at 9:00 a.m. on the 3RD day of JUNE, 2014.
 Karen E. Rushing
 Clerk Of The Circuit Court
 Sarasota County, Florida
 By: T. Lake, Deputy Clerk
 Publication Dates: MAY 2, 9, 16, 23 2014
 14-01878S

SECOND INSERTION

ADVERTISEMENT OF SALE
 NOTICE IS HEREBY GIVEN THAT BUDGET SELF STORAGE INTENDS TO SELL THE PERSONAL PROPERTY DESCRIBED BELOW TO ENFORCE A LIEN IMPOSED ON SAID PROPERTY UNDER THE FLORIDA SELF STORAGE FACILITY ACT STATUTES (SECTION 83.801-83.809). THE OWNER WILL SELL AT PUBLIC SALE ON WEDNESDAY, THE 4TH OF JUNE 2014, AT THE LOCATIONS AND TIMES INDICATED BELOW.
BUDGET SELF STORAGE
 5425 N. Washington Blvd Sarasota, FL 34234 @ ...2.00PM. THE FOLLOWING:

NAME	UNIT#	ITEMS STORED
Ronald Ward	B24	household/business equip
Karen L Chester	B25B26	Household
Edward Knapp	B58	Building Material
Evette Carter	D26	Personal Items
Marshall Barnwell	D37	Household Goods
Ruben Huerta	G15	Household Goods
Sarah Dillard	G19	Household Items
Rosalind L McCloud	G21	Household
Lucretia Clark	1121	Household Goods
Jaimie L George	1177	Household Items
Barbara Campbell	xx12	Household Items
Mamie Lawson	E41	Household Goods

 2201 FRUITVILLE RD. SARASOTA FL 34237. @ 3:00 PM. THE FOLLOWING:

NAME	UNIT#	ITEMS STORED
Darien Grable	0198A	Household Goods
David Vincent	0358D	Household Goods
Eric Insinna	0383D	Household Goods
Todd M Hoover	2069D	Household

 4029 Bee Ridge Rd., Sarasota, FL. 34233... @ 4:00 PM. THE FOLLOWING:

NAME	UNIT#	ITEMS STORED
TARA HAYNES	84243	household
MICHELLE ECKMAN	213	household
MARK BROWN	636	household
LAVONNE TRIPLETT	418	household
Liz Ledbetter	608	household
CHRISTOPHER ORR	508	hbg

 SALE SUBJECT TO CANCELLATION IN THE EVENT OF SETTLEMENT. SHOULD IT BE IMPOSSIBLE TO DISPOSE OF THESE GOODS ON THE DAY OF SALE, THE SALE WILL BE CONTINUED ON SUCH SUCCEEDING DAYS THEREAFTER AS MAY BE NECESSARY TO COMPLETE THE SALE.
 May 16, 23, 2014 14-02219S

PUBLISH YOUR LEGAL NOTICES IN THE BUSINESS OBSERVER
 (813) 221-9505 Hillsborough, Pasco
 (727) 447-7784 Pinellas
 (941) 906-9386 Manatee, Sarasota, Lee
 (239) 263-0122 Collier
 (941) 249-4900 Charlotte
 (407) 654-5500 Orange

FOURTH INSERTION

NOTICE OF APPLICATION FOR TAX DEED

Notice is hereby given that KIRK TRENCHFIELD & PURIS ENVIRONMENTAL INC, the holder of the certificate listed below, has filed said certificate for a tax deed to be issued. The certificate number and year of issuance, the description of the property, and the names in which the property is assessed are as follows:

Certificate Number: 9927.000
Year of Issuance: 2012
Tax Deed File #: 14-0027 TD

Description of Property: 1138076715 LOT 15 BLK 767 12TH ADD TO PORT CHARLOTTE

Name in which the property is assessed: CHARLES W BRYANT

All of said property being in the County of Sarasota, State of Florida. Unless the certificate is redeemed according to law, the property described in the certificate will be sold to the highest bidder at the Sarasota County Court House, 2000 Main Street, Historic Courtroom, East Wing, Sarasota, Florida, at 9:00 a.m. on the 3RD day of JUNE, 2014.

Karen E. Rushing
Clerk Of The Circuit Court
Sarasota County, Florida
By: T. Lake, Deputy Clerk

Publication Dates: MAY 2, 9, 16, 23
2014

14-01874S

FOURTH INSERTION

NOTICE OF APPLICATION FOR TAX DEED

Notice is hereby given that SKW PREP LLC, the holder of the certificate listed below, has filed said certificate for a tax deed to be issued. The certificate number and year of issuance, the description of the property, and the names in which the property is assessed are as follows:

Certificate Number: 10504.000
Year of Issuance: 2008
Tax Deed File #: 14-0018 TD

Description of Property: 1137159232 LOT 32 BLK 1592 32ND ADD TO PORT CHARLOTTE

Name in which the property is assessed: PHILIP DAVIS

All of said property being in the County of Sarasota, State of Florida. Unless the certificate is redeemed according to law, the property described in the certificate will be sold to the highest bidder at the Sarasota County Court House, 2000 Main Street, Historic Courtroom, East Wing, Sarasota, Florida, at 9:00 a.m. on the 3RD day of JUNE, 2014.

Karen E. Rushing
Clerk Of The Circuit Court
Sarasota County, Florida
By: T. Lake, Deputy Clerk

Publication Dates: MAY 2, 9, 16, 23
2014

14-01869S

FOURTH INSERTION

NOTICE OF APPLICATION FOR TAX DEED

Notice is hereby given that KOMAL OF USA LLC, the holder of the certificate listed below, has filed said certificate for a tax deed to be issued. The certificate number and year of issuance, the description of the property, and the names in which the property is assessed are as follows:

Certificate Number: 1888.000
Year of Issuance: 2012
Tax Deed File #: 14-0030 TD

Description of Property: 0141160012 LOT 5, OSPREY WOODS

Name in which the property is assessed: RONALD R SHENKIN

All of said property being in the County of Sarasota, State of Florida. Unless the certificate is redeemed according to law, the property described in the certificate will be sold to the highest bidder at the Sarasota County Court House, 2000 Main Street, Historic Courtroom, East Wing, Sarasota, Florida, at 9:00 a.m. on the 3RD day of JUNE, 2014.

Karen E. Rushing
Clerk Of The Circuit Court
Sarasota County, Florida
By: T. Lake, Deputy Clerk

Publication Dates: MAY 2, 9, 16, 23
2014

14-01877S

SECOND INSERTION

NOTICE TO CREDITORS IN THE CIRCUIT COURT FOR SARASOTA COUNTY, FLORIDA PROBATE DIVISION

File No. 2014-CP-001660-NC
IN RE: ESTATE OF BARRY SHUMAN, Deceased.

The administration of the estate of Barry Shuman, deceased, whose date of death was March 8, 2013, is pending in the Circuit Court for Sarasota County, Florida, Probate Division, the address of which is 2000 Main Street, Room 102, Sarasota, FL 34237. The name and address of the personal representative is set forth below.

All creditors of the decedent and other persons having claims or demands against decedent's estate on whom a copy of this notice is required to be served must file their claims with this court WITHIN THE LATER OF 3 MONTHS AFTER THE TIME OF THE FIRST PUBLICATION OF THIS NOTICE OR 30 DAYS AFTER THE DATE OF SERVICE OF A COPY OF THIS NOTICE ON THEM.

All other creditors of the decedent and other persons having claims or demands against decedent's estate must file their claims with this court WITHIN 3 MONTHS AFTER THE DATE OF THE FIRST PUBLICATION OF THIS NOTICE.

ALL CLAIMS NOT FILED WITHIN THE TIME PERIODS SET FORTH IN SECTION 733.702 OF THE FLORIDA PROBATE CODE WILL BE FOREVER BARRED.

NOTWITHSTANDING THE TIME PERIODS SET FORTH ABOVE, ANY CLAIM FILED TWO (2) YEARS OR MORE AFTER THE DECEDENT'S DATE OF DEATH IS BARRED.

The date of first publication of this notice is May 16, 2014.

By: **Alan M. Oravec, Esquire**

6701 Avenue A., Apt. 8
Sarasota, Florida 34230
Telephone: (941) 922-9339
Email: alan@srqlawyers.com

Personal Representative
May 16, 23, 2014 14-02154S

SECOND INSERTION

NOTICE TO CREDITORS IN THE CIRCUIT COURT FOR SARASOTA COUNTY, FLORIDA PROBATE DIVISION

File No: 2014 CP 001891 SC
Division Probate
IN RE: ESTATE OF ROXANNE L. ROCHESTER Deceased.

The administration of the Estate of Roxanne L. Rochester, deceased, whose date of death was April 12, 2014, is pending in the Circuit Court for Sarasota County, Florida, Probate Division, the address of which is 4000 S. Tamiami Trail, Venice, FL 34293. The names and addresses of the personal representative and the personal representative's attorney are set forth below.

All creditors of the decedent and other persons having claims or demands against decedent's estate on whom a copy of this notice is required to be served must file their claims with this court WITHIN THE LATER OF 3 MONTHS AFTER THE TIME OF THE FIRST PUBLICATION OF THIS NOTICE OR 30 DAYS AFTER THE DATE OF SERVICE OF A COPY OF THIS NOTICE ON THEM.

All other creditors of the decedent and other persons having claims or demands against decedent's estate must file their claims with this court WITHIN 3 MONTHS AFTER THE DATE OF THE FIRST PUBLICATION OF THIS NOTICE.

ALL CLAIMS NOT FILED WITHIN THE TIME PERIODS SET FORTH IN SECTION 733.702 OF THE FLORIDA PROBATE CODE WILL BE FOREVER BARRED.

NOTWITHSTANDING THE TIME PERIODS SET FORTH ABOVE, ANY CLAIM FILED TWO (2) YEARS OR MORE AFTER THE DECEDENT'S DATE OF DEATH IS BARRED.

The date of first publication of this notice is May 16, 2014.

Personal Representative

John J. Marhofer
c/o Mazzeo & Staas, P.L.,
4140 Woodmere Park Blvd., Ste. 4
Venice, FL 34293

Attorney for Personal Representative:
Kevin G. Staas, Esq.
Florida Bar Number: 196045
Mazzeo & Staas, P.L.
4140 Woodmere Park Blvd., Ste. 4
Venice, FL 34293

Telephone: (941) 408-8555
Fax: (941) 408-8556
Email: e-service@veniceelderlaw.com

Secondary Email:
kstaas@veniceelderlaw.com
May 16, 23, 2014 14-02220S

SECOND INSERTION

NOTICE OF APPLICATION FOR TAX DEED

Notice is hereby given that GERALD L DICKERHOOF, the holder of the certificate listed below, has filed said certificate for a tax deed to be issued. The certificate number and year of issuance, the description of the property, and the names in which the property is assessed are as follows:

Certificate Number: 5519.000
Year of Issuance: 2012
Tax Deed File #: 14-0032 TD

Description of Property: 0958067716 LOTS 16 & 17 BLK 677 17TH ADD TO PORT CHARLOTTE

Name in which the property is assessed: SARASOTA PRESERVATION SOC INC

All of said property being in the County of Sarasota, State of Florida. Unless the certificate is redeemed according to law, the property described in the certificate will be sold to the highest bidder at the Sarasota County Court House, 2000 Main Street, Historic Courtroom, East Wing, Sarasota, Florida, at 9:00 a.m. on the 17TH day of JUNE, 2014.

Karen E. Rushing
Clerk Of The Circuit Court
Sarasota County, Florida
By: T. Lake, Deputy Clerk

Publication Dates: MAY 16, 23, 30;
JUNE 6, 2014

14-02180S

SECOND INSERTION

NOTICE OF APPLICATION FOR TAX DEED

Notice is hereby given that CITRUS CAPITAL LLC - SERIES 44 US BANK % CITRUS CAPITAL LLC, the holder of the certificate listed below, has filed said certificate for a tax deed to be issued. The certificate number and year of issuance, the description of the property, and the names in which the property is assessed are as follows:

Certificate Number: 38.000
Year of Issuance: 2012
Tax Deed File #: 14-0033 TD

Description of Property: 0008141014 UNIT 204 BLDG G-4 SEAPLACE 3

Name in which the property is assessed: ILLE A WATERS

All of said property being in the County of Sarasota, State of Florida. Unless the certificate is redeemed according to law, the property described in the certificate will be sold to the highest bidder at the Sarasota County Court House, 2000 Main Street, Historic Courtroom, East Wing, Sarasota, Florida, at 9:00 a.m. on the 17TH day of JUNE, 2014.

Karen E. Rushing
Clerk Of The Circuit Court
Sarasota County, Florida
By: T. Lake, Deputy Clerk

Publication Dates: MAY 16, 23, 30;
JUNE 6, 2014

14-02181S

SECOND INSERTION

NOTICE OF APPLICATION FOR TAX DEED

Notice is hereby given that CITRUS CAPITAL LLC - SERIES 44 US BANK % CITRUS CAPITAL LLC, the holder of the certificate listed below, has filed said certificate for a tax deed to be issued. The certificate number and year of issuance, the description of the property, and the names in which the property is assessed are as follows:

Certificate Number: 674.000
Year of Issuance: 2012
Tax Deed File #: 14-0034 TD

Description of Property: 0056050040 LOTS 2 & 3 BLK H GROVELAWN REV

Name in which the property is assessed: NANCY L SMALLWOOD & MATTHEW S SMALLWOOD

All of said property being in the County of Sarasota, State of Florida. Unless the certificate is redeemed according to law, the property described in the certificate will be sold to the highest bidder at the Sarasota County Court House, 2000 Main Street, Historic Courtroom, East Wing, Sarasota, Florida, at 9:00 a.m. on the 17TH day of JUNE, 2014.

Karen E. Rushing
Clerk Of The Circuit Court
Sarasota County, Florida
By: T. Lake, Deputy Clerk

Publication Dates: MAY 16, 23, 30;
JUNE 6, 2014

14-02182S

NOTICE OF FORECLOSURE SALE IN THE CIRCUIT COURT OF THE TWELFTH JUDICIAL CIRCUIT IN AND FOR SARASOTA COUNTY, FLORIDA GENERAL JURISDICTION DIVISION

CASE NO. 2013 CA 005030 NC
CITIMORTGAGE, INC., Plaintiff, vs.

DIRLEI DEOLIVEIRA; STELAMAR DEOLIVEIRA A/K/A STELAMAR DASILVA DEOLIVEIRA; et. AL Defendant(s).

NOTICE IS HEREBY GIVEN pursuant to a Final Judgment of Foreclosure dated February 24, 2014, and entered

SECOND INSERTION

NOTICE OF APPLICATION FOR TAX DEED

Notice is hereby given that CITRUS CAPITAL LLC - SERIES 44 US BANK % CITRUS CAPITAL LLC, the holder of the certificate listed below, has filed said certificate for a tax deed to be issued. The certificate number and year of issuance, the description of the property, and the names in which the property is assessed are as follows:

Certificate Number: 903.000
Year of Issuance: 2012
Tax Deed File #: 14-0035 TD

Description of Property: 0065120037 LOT 585 RIDGEWOOD ESTATES 11TH ADD

Name in which the property is assessed: LINDA HARKIN

All of said property being in the County of Sarasota, State of Florida. Unless the certificate is redeemed according to law, the property described in the certificate will be sold to the highest bidder at the Sarasota County Court House, 2000 Main Street, Historic Courtroom, East Wing, Sarasota, Florida, at 9:00 a.m. on the 17TH day of JUNE, 2014.

Karen E. Rushing
Clerk Of The Circuit Court
Sarasota County, Florida
By: T. Lake, Deputy Clerk

Publication Dates: MAY 16, 23, 30;
JUNE 6, 2014

14-02183S

SECOND INSERTION

NOTICE OF APPLICATION FOR TAX DEED

Notice is hereby given that CITRUS CAPITAL LLC - SERIES 44 US BANK % CITRUS CAPITAL LLC, the holder of the certificate listed below, has filed said certificate for a tax deed to be issued. The certificate number and year of issuance, the description of the property, and the names in which the property is assessed are as follows:

Certificate Number: 931.000
Year of Issuance: 2012
Tax Deed File #: 14-0036 TD

Description of Property: 0066040060 LOT 16 BLK 4 SOUTHRIDGE UNIT 1

Name in which the property is assessed: STACIE D MULLINS TTEE & JONES FAMILY LAND TRUST

All of said property being in the County of Sarasota, State of Florida. Unless the certificate is redeemed according to law, the property described in the certificate will be sold to the highest bidder at the Sarasota County Court House, 2000 Main Street, Historic Courtroom, East Wing, Sarasota, Florida, at 9:00 a.m. on the 17TH day of JUNE, 2014.

Karen E. Rushing
Clerk Of The Circuit Court
Sarasota County, Florida
By: T. Lake, Deputy Clerk

Publication Dates: MAY 16, 23, 30;
JUNE 6, 2014

14-02184S

SECOND INSERTION

NOTICE OF APPLICATION FOR TAX DEED

Notice is hereby given that CITRUS CAPITAL LLC - SERIES 44 US BANK % CITRUS CAPITAL LLC, the holder of the certificate listed below, has filed said certificate for a tax deed to be issued. The certificate number and year of issuance, the description of the property, and the names in which the property is assessed are as follows:

Certificate Number: 987.000
Year of Issuance: 2012
Tax Deed File #: 14-0037 TD

Description of Property: 0070052036 UNIT 313 TREGATE EAST

Name in which the property is assessed: STACEY COURSEY & JASON CUNDIFF & PAIGE CUNDIFF

All of said property being in the County of Sarasota, State of Florida. Unless the certificate is redeemed according to law, the property described in the certificate will be sold to the highest bidder at the Sarasota County Court House, 2000 Main Street, Historic Courtroom, East Wing, Sarasota, Florida, at 9:00 a.m. on the 17TH day of JUNE, 2014.

Karen E. Rushing
Clerk Of The Circuit Court
Sarasota County, Florida
By: T. Lake, Deputy Clerk

Publication Dates: MAY 16, 23, 30;
JUNE 6, 2014

14-02185S

SECOND INSERTION

NOTICE OF APPLICATION FOR TAX DEED

Notice is hereby given that CITRUS CAPITAL LLC - SERIES 44 US BANK % CITRUS CAPITAL LLC, the holder of the certificate listed below, has filed said certificate for a tax deed to be issued. The certificate number and year of issuance, the description of the property, and the names in which the property is assessed are as follows:

Certificate Number: 1216.000
Year of Issuance: 2012
Tax Deed File #: 14-0038 TD

Description of Property: 0084011012 UNIT 102 BLDG 2 LANDINGS SOUTH 5

Name in which the property is assessed: RUTH GOLDFOND

All of said property being in the County of Sarasota, State of Florida. Unless the certificate is redeemed according to law, the property described in the certificate will be sold to the highest bidder at the Sarasota County Court House, 2000 Main Street, Historic Courtroom, East Wing, Sarasota, Florida, at 9:00 a.m. on the 17TH day of JUNE, 2014.

Karen E. Rushing
Clerk Of The Circuit Court
Sarasota County, Florida
By: T. Lake, Deputy Clerk

Publication Dates: MAY 16, 23, 30;
JUNE 6, 2014

14-02186S

SECOND INSERTION

NOTICE OF APPLICATION FOR TAX DEED

Notice is hereby given that CITRUS CAPITAL LLC - SERIES 44 US BANK % CITRUS CAPITAL LLC, the holder of the certificate listed below, has filed said certificate for a tax deed to be issued. The certificate number and year of issuance, the description of the property, and the names in which the property is assessed are as follows:

Certificate Number: 1579.000
Year of Issuance: 2012
Tax Deed File #: 14-0041 TD

Description of Property: 0103151019 UNIT 218 BLDG 2 TREGATE MANOR

Name in which the property is assessed: FRANK J LAMBERT TR & MARY L REGAS TTEE

All of said property being in the County of Sarasota, State of Florida. Unless the certificate is redeemed according to law, the property described in the certificate will be sold to the highest bidder at the Sarasota County Court House, 2000 Main Street, Historic Courtroom, East Wing, Sarasota, Florida, at 9:00 a.m. on the 17TH day of JUNE, 2014.

Karen E. Rushing
Clerk Of The Circuit Court
Sarasota County, Florida
By: T. Lake, Deputy Clerk

Publication Dates: MAY 16, 23, 30;
JUNE 6, 2014

14-02188S

SECOND INSERTION

NOTICE OF APPLICATION FOR TAX DEED

Notice is hereby given that CITRUS CAPITAL LLC - SERIES 44 US BANK % CITRUS CAPITAL LLC, the holder of the certificate listed below, has filed said certificate for a tax deed to be issued. The certificate number and year of issuance, the description of the property, and the names in which the property is assessed are as follows:

Certificate Number: 2756.000
Year of Issuance: 2012
Tax Deed File #: 14-0043 TD

Description of Property: 0405050003 LOT 2 NOKOMIS ACRES

Name in which the property is assessed: BETTY L MOREMEN

All of said property being in the County of Sarasota, State of Florida. Unless the certificate is redeemed according to law, the property described in the certificate will be sold to the highest bidder at the Sarasota County Court House, 2000 Main Street, Historic Courtroom, East Wing, Sarasota, Florida, at 9:00 a.m. on the 17TH day of JUNE, 2014.

Karen E. Rushing
Clerk Of The Circuit Court
Sarasota County, Florida
By: T. Lake, Deputy Clerk

Publication Dates: MAY 16, 23, 30;
JUNE 6, 2014

14-02190S

SECOND INSERTION

PARK UNIT 3, ACCORDING TO THE PLAT THEREOF, AS RECORDED IN PLAT BOOK 10, PAGES 71 AND 71A, OF THE PUBLIC RECORDS OF SARASOTA COUNTY, FLORIDA.

Any person claiming an interest in the surplus from the sale, if any, other than the property owner as of the date of the lis pendens must file a claim within 60 days after the sale.

If you are a person with a disability who needs any accommodation in order to participate in this proceeding, you are entitled, at no cost to you, to the provision of certain assistance. Please contact the Sarasota County Jury

SECOND INSERTION

NOTICE OF APPLICATION FOR TAX DEED

Notice is hereby given that CITRUS CAPITAL LLC - SERIES 44 US BANK % CITRUS CAPITAL LLC, the holder of the certificate listed below, has filed said certificate for a tax deed to be issued. The certificate number and year of issuance, the description of the property, and the names in which the property is assessed are as follows:

Certificate Number: 1313.000
Year of Issuance: 2012
Tax Deed File #: 14-0039 TD

Description of Property: 0086090057 LOT 307 PHILLIPPI GARDENS UNIT 14

Name in which the property is assessed: STACY MORTON & DENNIS MORTON

All of said property being in the County of Sarasota, State of Florida. Unless the certificate is redeemed according to law, the property described in the certificate will be sold to the highest bidder at the Sarasota County Court House, 2000 Main Street, Historic Courtroom, East Wing, Sarasota, Florida, at 9:00 a.m. on the 17TH day of JUNE, 2014.

Karen E. Rushing
Clerk Of The Circuit Court
Sarasota County, Florida
By: T. Lake, Deputy Clerk

Publication Dates: MAY 16, 23, 30;
JUNE 6, 2014

14-02187S

SECOND INSERTION

NOTICE OF APPLICATION FOR TAX DEED

Notice is hereby given that CITRUS CAPITAL LLC - SERIES 44 US BANK % CITRUS CAPITAL LLC, the holder of the certificate listed below, has filed said certificate for a tax deed to be issued. The certificate number and year of issuance, the description of the property, and the names in which the property is assessed are as follows:

Certificate Number: 1769.000
Year of Issuance: 2012
Tax Deed File #: 14-0042 TD

Description of Property: 0124021201 UNIT 21, BLDG 13, VINTAGE GRAND

Name in which the property is assessed: CONSTANCE R BRICKELS & RONALD S SIMONS

All of said property being in the County of Sarasota, State of Florida. Unless the certificate is redeemed according to law, the property described in the certificate will be sold to the highest bidder at the Sarasota County Court House, 2000 Main Street, Historic Courtroom, East Wing, Sarasota, Florida, at 9:00 a.m. on the 17TH day of JUNE, 2014.

Karen E. Rushing
Clerk Of The Circuit Court
Sarasota County, Florida
By: T. Lake, Deputy Clerk

Publication Dates: MAY 16, 23, 30;
JUNE 6, 2014

14-02189S

SECOND INSERTION

NOTICE OF APPLICATION FOR TAX DEED

Notice is hereby given that CITRUS CAPITAL LLC - SERIES 44 US BANK % CITRUS CAPITAL LLC, the holder of the certificate listed below, has filed said certificate for a tax deed to be issued. The certificate number and year of issuance, the description of the property, and the names in which the property is assessed are as follows:

SECOND INSERTION

NOTICE OF ACTION - CONSTRUCTIVE SERVICE IN THE CIRCUIT COURT OF THE TWELFTH JUDICIAL CIRCUIT OF FLORIDA IN AND FOR SARASOTA COUNTY

GENERAL JURISDICTION DIVISION

CASE NO. 2012 CA 004602 NC ONEWEST BANK, FSB, Plaintiff, vs. MAXINE T. BROWN, TRUSTEE OF THE MAXINE T. BROWN REVOCABLE LIVING TRUST DATED MAY 6, 2005, et al Defendant(s),

TO: THE UNKNOWN BENEFICIARIES OF THE MAXINE T. BROWN REVOCABLE LIVING TRUST DATED MAY 6, 2005 AND UNKNOWN SUCCESSOR TRUSTEE OF THE MAXINE T. BROWN REVOCABLE LIVING TRUST DATED MAY 6, 2005

whose residence is unknown if he/she/they be living; and if he/she/they be dead, the unknown defendants who may be spouses, heirs, devisees, grantees, assignees, lienors, creditors, trustees, and all parties claiming an interest by, through, under or against the Defendants, who are not known to be dead or alive, and all parties having or claiming to have any right, title or interest in the property described in the mortgage being foreclosed herein.

YOU ARE HEREBY NOTIFIED that an action to foreclose a mortgage on the following property:

Condominium Unit 502A, Building A, PEPPERTREE BAY UNIT 4, A CONDOMINIUM, together with an undivided interest in the common elements, according to the Declaration of Condominium thereof recorded in Official Record Book 1056, Page 1813, as amended from time to time, of the Pub-

lic Records of Sarasota County, Florida. has been filed against you and you are required to serve a copy of your written defenses, if any, to it on counsel for Plaintiff, whose address is 6409 Congress Avenue, Suite 100, Boca Raton, Florida 33487 on or before 6-16-2014 / (30 days from Date of First Publication of this Notice) and file the original with the clerk of this court either before service on Plaintiff's attorney or immediately thereafter; otherwise a default will be entered against you for the relief demanded in the complaint or petition filed herein.

If you are a person with a disability who needs any accommodation in order to participate in this proceeding, you are entitled, at no cost to you, to the provision of certain assistance. Please contact the Sarasota County Jury Office, P.O. Box 3079, Sarasota, Florida 34230-3079, (941)861-7400, at least seven (7) days before your scheduled court appearance, or immediately upon receiving this notification if the time before the scheduled appearance is less than seven (7) days; if you are hearing or voice impaired, call 711.

WITNESS my hand and the seal of this Court at Sarasota County, Florida, this 2 day of May, 2014.

KAREN E. RUSHING, CLERK OF THE CIRCUIT COURT (SEAL) BY: G. Kopinsky DEPUTY CLERK

ROBERTSON, ANSCHUTZ, AND SCHNEID, PL ATTORNEY FOR PLAINTIFF 6409 CONGRESS AVENUE, SUITE 100 BOCA RATON, FL 33487 PRIMARY EMAIL: mail@rasflaw.com 13-22681 May 16, 23, 2014 14-02108S

SECOND INSERTION

NOTICE OF ACTION IN THE COUNTY COURT OF THE TWELFTH JUDICIAL CIRCUIT IN AND FOR SARASOTA COUNTY, FLORIDA

CIVIL DIVISION

CASE NO.: 2014 CC 000098 NC VISTA BAY POINT CONDOMINIUM ASSOCIATION, INC., a Florida not for profit corporation, Plaintiff, vs. JAMES E. HUJDA; UNKNOWN SPOUSE OF JAMES E. HUJDA; UNKNOWN TENANT #1 and UNKNOWN TENANT #2 (as unknown persons in possession), Defendants.

STATE OF FLORIDA COUNTY OF SARASOTA TO: JAMES E. HUJDA and UNKNOWN SPOUSE OF JAMES E. HUJDA

Last Known Address: 10436 Williamsburg Trail, Frankfort, IL 60423

YOU ARE NOTIFIED that an action has been filed against you to foreclose a Claim of Lien on the following described property:

Unit 402 of VISTA BAY POINT, a Condominium according to the Declaration of Condominium thereof, recorded in Official Records Instrument No. 2004063935, and any amendments thereto, and as per plat thereof recorded in Condominium Book 36, Page 41, 41A through 41M, inclusive, and any amendments thereto, of the Public Records of Sarasota County, Florida, together with its undivided share in the common elements.

Together with the Right of Use of Parking Garage Number GA-

04 and Storage Unit Number BS-A04 as Limited Common Elements appurtenant to the above referenced Condominium Unit.

You are required to serve a copy of your written defenses, if any, to Plaintiff's attorney, Kelly M. Fernandez, Esq., Persson & Cohen, P.A., 6853 Energy Ct., Lakewood Ranch, Florida 34240 on or before thirty (30) days from the first date of publication, and file the original with the Clerk of this Court either before service on Plaintiff's attorney or immediately thereafter. If you fail to do so, a default will be entered against you for the relief demanded in the Amended Complaint.

If you are a person with a disability who needs any accommodation in order to participate in this proceeding, you are entitled, at no cost to you, to the provision of certain assistance. Please contact the Sarasota County Jury Office, P.O. Box 3079, Sarasota, Florida 34230-3079, (941)861-7400, at least seven (7) days before your scheduled court appearance, or immediately upon receiving this notification if the time before the scheduled appearance is less than seven (7) days; if you are hearing or voice impaired, call 711.

WITNESS my hand and seal of said Court on this 7 day of May, 2014.

KAREN E. RUSHING CLERK OF THE COURT (SEAL) BY: C. Brandenburg Deputy Clerk

Attorney for Plaintiff: Kelly M. Fernandez, Esquire PERSSON & COHEN, P.A. 6853 Energy Ct. Lakewood Ranch, Florida 34240 May 16, 23,, 2014 14-02101S

SECOND INSERTION

NOTICE OF ACTION IN THE CIRCUIT COURT OF THE TWELFTH JUDICIAL CIRCUIT IN AND FOR SARASOTA COUNTY, FLORIDA

CIVIL ACTION

CASE NO.: 58-2013-CA-004366 NC DIVISION: A

WELLS FARGO BANK, NA, Plaintiff, vs. THE UNKNOWN HEIRS, DEVISEES, GRANTEES, ASSIGNEES, LIENORS, CREDITORS, TRUSTEES, OR OTHER CLAIMANTS CLAIMING BY, THROUGH, UNDER, OR AGAINST, HOWARD E. BOHNSACK, DECEASED, et al, Defendant(s).

TO: THE UNKNOWN HEIRS, DEVISEES, GRANTEES, ASSIGNEES, LIENORS, CREDITORS, TRUSTEES, OR OTHER CLAIMANTS CLAIMING BY, THROUGH, UNDER, OR AGAINST, HOWARD E. BOHNSACK, DECEASED

Last Known Address: Unknown Current Address: Unknown

ANY AND ALL UNKNOWN PARTIES CLAIMING BY, THROUGH, UNDER, AND AGAINST THE HEREIN NAMED INDIVIDUAL DEFENDANT(S) WHO ARE NOT KNOWN TO BE DEAD OR ALIVE, WHETHER SAID UNKNOWN PARTIES MAY CLAIM AN INTEREST AS SPOUSES, HEIRS, DEVISEES, GRANTEES, OR OTHER CLAIMANTS

Last Known Address: Unknown Current Address: Unknown

YOU ARE NOTIFIED that an action to foreclose a mortgage on the following property in Sarasota County, Florida:

LOT 25, SARASOTA GOLF

CLUB COLONY, UNIT NO. 1, RECORDED IN PLAT BOOK 9, PAGE 94 AND 94A, OF THE PUBLIC RECORDS 011' SARASOTA COUNTY, FLORIDA. A/K/A 2136 W LEEWYNN DR SARASOTA FL 34240-8897

has been filed against you and you are required to serve a copy of your written defenses within 30 days after the first publication, if any, on Albertelli Law, Plaintiff's attorney, whose address is P.O. Box 23028, Tampa, FL 33623, and file the original with this Court either before June 16th, 2014 service on Plaintiff's attorney, or immediately thereafter; otherwise, a default will be entered against you for the relief demanded in the Complaint or petition.

This notice shall be published once a week for two consecutive weeks in the Business Observer.

If you are a person with a disability who needs any accommodation in order to participate in this proceeding, you are entitled, at no cost to you, to the provision of certain assistance. Please contact the Sarasota County Jury Office, P.O. Box 3079, Sarasota, Florida 34230-3079, (941)861-7400, at least seven (7) days before your scheduled court appearance, or immediately upon receiving this notification if the time before the scheduled appearance is less than seven (7) days; if you are hearing or voice impaired, call 711.

WITNESS my hand and the seal of this court on this 2 day of May, 2014.

KAREN E. RUSHING, CLERK OF THE CIRCUIT COURT (SEAL) BY: G. Kopinsky Deputy Clerk

Albertelli Law P.O. Box 23028 Tampa, FL 33623 PH-017441F01 May 16, 23, 2014 14-02093S

SECOND INSERTION

NOTICE OF ACTION FOR FORECLOSURE PROCEEDING-PROPERTY IN THE CIRCUIT COURT OF THE TWELFTH JUDICIAL CIRCUIT IN AND FOR SARASOTA COUNTY, FLORIDA

Case No.: 58-2014-CA-000973NC DEUTSCHE BANK NATIONAL TRUST COMPANY, AS TRUSTEE, IN TRUST FOR THE CERTIFICATE HOLDERS OF HARBORVIEW MORTGAGE LOAN TRUST SERIES 2005-7, MORTGAGE PASS-THROUGH CERTIFICATES SERIES, 2005-7 Plaintiff, v. JOHN F. WERNER, et al Defendant(s).

TO: CHRISTOPHER M. GROOMS AKA CHRISTOPHER GROOMS, ADDRESS UNKNOWN BUT WHOSE LAST KNOWN ADDRESS IS: 5174 NORTHTRIDGE ROAD UNIT 208 SARASOTA, FL 34238

Residence unknown, if living, including any unknown spouse of the said Defendants, if either has remarried and if either or both of said Defendant(s) are dead, their respective unknown heirs, devisees, grantees, assignees, creditors, lienors, and trustees, and all other persons claiming by, through, under or against the named Defendant(s); and the aforementioned named Defendant(s) and such of the aforementioned Defendants and such of the aforementioned unknown Defendant(s) as may be infants, incompetents or otherwise not sui juris.

YOU ARE HEREBY NOTIFIED that an action has been commenced to foreclose a mortgage on the following real property, lying and being and situated in Sarasota County, Florida, more particularly described as follows:

Unit 208, Building 7, Serenade on Palmer Ranch Condominium, according to the Declara-

tion of Condominium recorded in Official Records Instrument Number 2005045834, and amendments thereto, of the Public Records of Sarasota County, Florida.

COMMONLY KNOWN AS: 5174 Northridge Road, Unit 208, Sarasota, FL 34238-3745

This action has been filed against you and you are required to serve a copy of your written defense, if any, such as Morris Hardwick Schneider, LLC, Attorneys for Plaintiff, whose address is 5110 Eisenhower Blvd, Suite 302A, Tampa, FL 33634 on or before 6-16-2014, and file the original with the clerk of this Court either before service on Plaintiff's attorney or immediately thereafter; otherwise a default will be entered against you for the relief demanded in the Complaint.

If you are a person with a disability who needs any accommodation in order to participate in this proceeding, you are entitled, at no cost to you, to the provision of certain assistance. Please contact the Sarasota County Jury Office, P.O. Box 3079, Sarasota, Florida 34230-3079, (941)861-7400, at least seven (7) days before your scheduled court appearance, or immediately upon receiving this notification if the time before the scheduled appearance is less than seven (7) days; if you are hearing or voice impaired, call 711.

WITNESS my hand and seal of this Court on the 2 day of May, 2014.

KAREN E. RUSHING, CLERK OF THE Circuit Court (SEAL) BY: G. Kopinsky Deputy Clerk

MORRIS | HARDWICK | SCHNEIDER, LLC Attorneys for Plaintiff 5110 Eisenhower Blvd, Suite 302A, Tampa, FL 33634 FL-97008402-12-lit 10403346 May 16, 23, 2014 14-02100S

SECOND INSERTION

NOTICE OF ACTION IN THE CIRCUIT COURT OF THE TWELFTH JUDICIAL CIRCUIT IN AND FOR SARASOTA COUNTY, FLORIDA

CIVIL ACTION

CASE NO.: 58-2013-CA-005484 NC DIVISION: A

NATIONSTAR MORTGAGE LLC DBA CHAMPION MORTGAGE COMPANY, Plaintiff, vs. THE UNKNOWN HEIRS, DEVISEES, GRANTEES, ASSIGNEES, LIENORS, CREDITORS, TRUSTEES, OR OTHER CLAIMANTS CLAIMING BY, THROUGH, UNDER, OR AGAINST, PATRICIA C. COVALT ALSO KNOWN AS PATRICIA COVALT, DECEASED, et al, Defendant(s).

TO: THE UNKNOWN HEIRS, DEVISEES, GRANTEES, ASSIGNEES, LIENORS, CREDITORS, TRUSTEES, OR OTHER CLAIMANTS CLAIMING BY, THROUGH, UNDER, OR AGAINST, PATRICIA C. COVALT ALSO KNOWN AS PATRICIA COVALT, DECEASED

Last Known Address: Unknown Current Address: Unknown

ANY AND ALL UNKNOWN PARTIES CLAIMING BY, THROUGH, UNDER, AND AGAINST THE HEREIN NAMED INDIVIDUAL DEFENDANT(S) WHO ARE NOT KNOWN TO BE DEAD OR ALIVE, WHETHER SAID UNKNOWN PARTIES MAY CLAIM AN INTEREST AS SPOUSES, HEIRS, DEVISEES, GRANTEES, OR OTHER CLAIMANTS

Last Known Address: Unknown Current Address: Unknown

YOU ARE NOTIFIED that an action to foreclose a mortgage on the following property in Sarasota County, Florida:

LOT 5, BLOCK 92, UNIT 4,

GULF GATE WOODS, ACCORDING TO THE PLAT THEREOF, RECORDED IN PLAT BOOK 21, PAGE 35, OF THE PUBLIC RECORDS OF SARASOTA COUNTY, FLORIDA

A/K/A 2943 TUCKERSTOWN DR SARASOTA FL 34231-6933

has been filed against you and you are required to serve a copy of your written defenses within 30 days after the first publication, if any, on Albertelli Law, Plaintiff's attorney, whose address is P.O. Box 23028, Tampa, FL 33623, and file the original with this Court either before June 16th, 2014 service on Plaintiff's attorney, or immediately thereafter; otherwise, a default will be entered against you for the relief demanded in the Complaint or petition.

This notice shall be published once a week for two consecutive weeks in the Business Observer.

If you are a person with a disability who needs any accommodation in order to participate in this proceeding, you are entitled, at no cost to you, to the provision of certain assistance. Please contact the Sarasota County Jury Office, P.O. Box 3079, Sarasota, Florida 34230-3079, (941)861-7400, at least seven (7) days before your scheduled court appearance, or immediately upon receiving this notification if the time before the scheduled appearance is less than seven (7) days; if you are hearing or voice impaired, call 711.

WITNESS my hand and the seal of this court on this 5th day of May, 2014.

KAREN E. RUSHING, CLERK OF THE Circuit Court (SEAL) BY: L. Szymanski Deputy Clerk

Albertelli Law P.O. Box 23028 Tampa, FL 33623 EF-016937F01 May 16, 23, 2014 14-02092S

SECOND INSERTION

NOTICE OF ACTION IN THE CIRCUIT COURT OF THE TWELFTH JUDICIAL CIRCUIT IN AND FOR SARASOTA COUNTY, FLORIDA

CASE NO.: 2009 CA 002663 NC

AURORA LOAN SERVICES, LLC, Plaintiff, vs. THE ESTATE OF ELIZABETH ANN BLAZEK A/K/A ELIZABETH A. BLAZEK, DECEASED.; ANY AND ALL UNKNOWN PARTIES CLAIMING BY, THROUGH, UNDER, AND AGAINST THE HEREIN NAMED INDIVIDUAL DEFENDANT(S) WHO ARE NOT KNOWN TO BE DEAD OR ALIVE, WHETHER SAID UNKNOWN PARTIES MAY CLAIM AN INTEREST AS SPOUSES, HEIRS, DEVISEES, GRANTEES OR OTHER

CLAIMANTS; JOHN DOE AND JANE DOE AS UNKNOWN TENANTS IN POSSESSION; RENEE M. SOCHA; THOMAS J. LAMB; UNKNOWN HEIRS, BENEFICIARIES, DEVISEES, ASSIGNEES, LIENORS, CREDITORS, TRUSTEES AND ALL OTHERS WHO MAY CLAIM AN INTEREST IN THE ESTATE OF ELIZABETH ANN BLAZEK, DECEASED, UNKNOWN TENANT(S) IN POSSESSION # 1 and #2, et.al. Defendant(s).

TO: THE ESTATE OF ELIZABETH ANN BLAZEK A/K/A ELIZABETH A. BLAZEK, DECEASED (Last Known Address) 5340 LAURELWOOD PLACE SARASOTA, FL 34232 UNKNOWN HEIRS, BENEFICIARIES, DEVISEES, ASSIGNEES,

LIENORS, CREDITORS, TRUSTEES AND ALL OTHERS WHO MAY CLAIM AN INTEREST IN THE ESTATE OF ELIZABETH ANN BLAZEK, DECEASED (Last Known Address) 5340 LAURELWOOD PLACE SARASOTA, FL 34232 (Current Residence Unknown) if living, and ALL OTHER UNKNOWN PARTIES, including, if a named Defendant is deceased, the personal representatives, the surviving spouse, heirs, devisees, grantees, creditors, and all other parties claiming, by, through, under or against that Defendant, and all claimants, persons or parties, natural or corporate, or whose exact legal status is unknown, claiming under any of the above named or described Defendants

YOU ARE NOTIFIED that an action for Foreclosure of Mortgage on the fol-

lowing described property: LOTS 611 AND 612, OF THIRTEENTH ADDITION TO RIDGEWOOD ESTATES, ACCORDING TO THE PLAT THEREOF, AS RECORDED IN PLAT BOOK 19, AT PAGE 4, OF THE PUBLIC RECORDS OF SARASOTA COUNTY, FLORIDA.

A/K/A: 5340 LAURELWOOD PLACE, SARASOTA, FL 34232. has been filed against you and you are required to serve a copy of your written defenses, if any, to it on Brian L. Rosaler, Esquire, POPKIN & ROSALER, P.A., 1701 West Hillsboro Boulevard, Suite 400, Deerfield Beach, FL 33442., Attorney for Plaintiff, whose on or before June 16th, 2014, a date which is within thirty (30) days after the first publication of this Notice in the Busi-

ness Observer and file the original with the Clerk of this Court either before service on Plaintiff's attorney or immediately thereafter; otherwise, a default will be entered against you for the relief demanded in the complaint.

If you cannot afford an attorney, contact Gulfoast Legal Services at 366-1746 or www.gulfoastlegal.org, or Legal Aid of Manasota at 366-0038 or www.legalaidofmanasota.org. If you do not qualify for free legal assistance or do not know an attorney, you may email an attorney referral service (listed in phone book) or contact the Florida Bar Lawyer Referral Service at (800) 342-8011.

If you are a person with a disability who needs any accommodation in order to participate in this proceeding, you are entitled, at no cost to you, to the provision of certain assistance. Please contact the

Sarasota County Jury Office, P.O. Box 3079, Sarasota, Florida 34230-3079, (941)861-7400, at least seven (7) days before your scheduled court appearance, or immediately upon receiving this notification if the time before the scheduled appearance is less than seven (7) days; if you are hearing or voice impaired, call 711.

WITNESS my hand and the seal of this Court this 6th day of May, 2014.

KAREN E. RUSHING As Clerk of the Court (SEAL) BY: L. Szymanski As Deputy Clerk

Brian L. Rosaler, Esquire POPKIN & ROSALER, P.A., 1701 West Hillsboro Boulevard, Suite 400, Deerfield Beach, FL 33442 Attorney for Plaintiff 10-26039 May 16, 23, 2014 14-02105S

SAVE TIME E-mail your Legal Notice **legal@businessobserverfl.com** Wednesday Noon Deadline • Friday Publication **Business Observer** LV4681

SECOND INSERTION

NOTICE OF ACTION IN THE CIRCUIT COURT OF THE TWELFTH JUDICIAL CIRCUIT IN AND FOR SARASOTA COUNTY, FLORIDA

CASE NO.: 2013 CA 001081 NC WELLS FARGO BANK, NA. Plaintiff, vs.

EDWARD R. SEITZ, CO-TRUSTEE UNDER THE PROVISIONS OF THE EDWARD R. SEITZ; DOREEN B. KANEY, CO-TRUSTEE UNDER THE PROVISIONS OF THE EDWARD R. SEITZ; et al., Defendant(s).

TO: Edward R. Seitz
Last Known Residence: 774 Shorecrest Drive, Sarasota, FL 34232
Edward R. Seitz, Co-Trustee Under The Provisions of the Edward R. Seitz Revocable Trust Dated March 24, 2005
Last Known Residence: 774 Shorecrest Drive, Sarasota, FL 34232
Unknown Spouse of Edward R. Seitz as of 10/3/03

Last Known Residence: 774 Shorecrest Drive, Sarasota, FL 34232
Unknown Beneficiaries of the Edward R. Seitz Revocable Trust Dated March

24,2005

Last Known Residence: Unknown
YOU ARE HEREBY NOTIFIED that an action to foreclose a mortgage on the following property in SARASOTA County, Florida:

LOT 38, LESS THE WEST 26 FEET THEREOF AND ALL OF LOT 39, J.W. TATUM'S ADDITION TO SARASOTA HEIGHTS, ACCORDING TO THE PLAT THEREOF AS RECORDED IN PLAT BOOK 1, PAGE 189, PUBLIC RECORDS OF SARASOTA COUNTY, FLORIDA.

has been filed against you and you are required to serve a copy of your written defenses, if any, to it on ALDRIDGE | CONNORS, LLP, Plaintiff's attorney, at 1615 South Congress Avenue, Suite 200, Delray Beach, FL 33445 (Phone Number: (561) 392-6391), within 30 days of the first date of publication of this notice, and file the original with the clerk of this court either before June 16th, 2014 on Plaintiff's attorney or immediately thereafter; otherwise a default will be entered against you for

the relief demanded in the complaint or petition.

If you are a person with a disability who needs any accommodation in order to participate in this proceeding, you are entitled, at no cost to you, to the provision of certain assistance. Please contact the Sarasota County Jury Office, P.O. Box 3079, Sarasota, Florida 34230-3079, (941)861-7400, at least seven (7) days before your scheduled court appearance, or immediately upon receiving this notification if the time before the scheduled appearance is less than seven (7) days; if you are hearing or voice impaired, call 711.

Dated on May 8th, 2014.

KAREN E. RUSHING
As Clerk of the Court
(SEAL) By: L. Szymanski
As Deputy Clerk

ALDRIDGE | CONNORS, LLP
Plaintiff's Attorney
1615 South Congress Avenue,
Suite 200,
Delray Beach, FL 33445
Phone Number: (561) 392-6391
1113-8778
May 16, 23, 2014 14-02123S

SECOND INSERTION

NOTICE OF ACTION IN THE CIRCUIT COURT OF THE TWELFTH JUDICIAL CIRCUIT IN AND FOR

SARASOTA COUNTY, FLORIDA

CASE NO.: 2013-CA-002362-NC (A)

FEDERAL NATIONAL MORTGAGE ASSOCIATION, Plaintiff, vs.

ESTATE OF RICHARD G. KAYE; BANK OF AMERICA, N.A.; WEXFORD ON THE GREEN HOMEOWNERS ASSOCIATION, INC.; THE PLANTATION MANAGEMENT ASSOCIATION, INC.; CHARLES R. KAYE; DAVID A. KAYE A/K/A DAVID ALAN KAYE; DORIS ANN MUNDT; UNKNOWN HEIRS, BENEFICIARIES, DEVISEES, ASSIGNEES, LIENORS, CREDITORS, TRUSTEES AND ALL OTHERS WHO MAY CLAIM AN INTEREST IN THE ESTATE OF RICHARD G. KAYE, DECEASED; UNKNOWN TENANT(S) IN POSSESSION #1 and #2, et al. Defendant(s).

TO: ESTATE OF RICHARD G. KAYE (Last Known Address)
324 LANGHOLM DRIVE
VENICE, FL 34293

UNKNOWN HEIRS, BENEFICIARIES, DEVISEES, ASSIGNEES, LIENORS, CREDITORS, TRUSTEES AND ALL OTHERS WHO MAY CLAIM AN INTEREST IN THE ESTATE OF RICHARD G. KAYE, DECEASED

(Last Known Address)
324 LANGHOLM DRIVE
VENICE, FL 34293
(Current Residence Unknown) if liv-

ing, and ALL OTHER UNKNOWN PARTIES, including, if a named Defendant is deceased, the personal representatives, the surviving spouse, heirs, devisees, grantees, creditors, and all other parties claiming, by, through, under or against that Defendant, and all claimants, persons or parties, natural or corporate, or whose exact legal status is unknown, claiming under any of the above named or described Defendants

YOU ARE NOTIFIED that an action for Foreclosure of Mortgage on the following described property:

LOT 28, OF WEXFORD ON THE GREEN, PHASE 1, ACCORDING TO THE PLAT THEREOF AS RECORDED IN PLAT BOOK 38, PAGE 6, OF THE PUBLIC RECORDS OF SARASOTA COUNTY, FLORIDA.

A/K/A: 324 LANGHOLM DRIVE, VENICE, FL 34293.

has been filed against you and you are required to serve a copy of your written defenses, if any, to it on Brian L. Rosaler, Esquire, POPKIN & ROSALER, P.A., 1701 West Hillsboro Boulevard, Suite 400, Deerfield Beach, FL 33442., Attorney for Plaintiff, whose on or before June 6th, 2014, a date which is within thirty (30) days after the first publication of this Notice in the Business Observer and file the original with the Clerk of this Court either before service on Plaintiff's attorney or immediately thereafter; otherwise, a default will be entered against you for the relief demanded in the complaint.

If you cannot afford an attorney,

contact Gulfcoast Legal Services at 366-1746 or www.gulfcoastlegal.org, or Legal Aid of Manasota at 366-0038 or www.legalaidofmanasota.org. If you do not qualify for free legal assistance or do not know an attorney, you may email an attorney referral service (listed in phone book) or contact the Florida Bar Lawyer Referral Service at (800) 342-8011.

IF YOU ARE A PERSON WITH A DISABILITY WHO NEEDS ANY ACCOMMODATION IN ORDER TO PARTICIPATE IN THIS PROCEEDING, YOU ARE ENTITLED, AT NO COST TO YOU, TO THE PROVISION OF CERTAIN ASSISTANCE. PLEASE CONTACT THE SARASOTA COUNTY JURY OFFICE, P.O. BOX 3079, SARASOTA, FLORIDA 34230-3079, (941)861-7400, AT LEAST SEVEN (7) DAYS BEFORE YOUR SCHEDULED COURT APPEARANCE, OR IMMEDIATELY UPON RECEIVING THIS NOTIFICATION IF THE TIME BEFORE THE SCHEDULED APPEARANCE IS LESS THAN SEVEN (7) DAYS; IF YOU ARE HEARING OR VOICE IMPAIRED, CALL 711.

WITNESS my hand and the seal of this Court this 6th day of May, 2014.

KAREN E. RUSHING
As Clerk of the Court
(SEAL) By: L. Szymanski
As Deputy Clerk

Brian L. Rosaler, Esquire
POPKIN & ROSALER, P.A.,
1701 West Hillsboro Boulevard,
Suite 400,
Deerfield Beach, FL 33442
Attorney for Plaintiff
13-36173

May 16, 23, 2014 14-02106S

SECOND INSERTION

NOTICE OF ACTION IN THE CIRCUIT COURT OF THE TWELFTH JUDICIAL CIRCUIT IN AND FOR SARASOTA COUNTY, FLORIDA

CIVIL DIVISION

CASE NO.: 58-2012-CA-008424 NC

DIVISION: C

GMAC MORTGAGE, LLC

Plaintiff, v.

DEBORAH K. SARAQUSE A/K/A DEBORAH K. SARAQUSE; PAUL LAPLANT; MARVIN SARAQUSE; RICHARD LAPLANT; UNKNOWN SPOUSE OF RICHARD LAPLANT; UNKNOWN SPOUSE OF PAUL LAPLANT; UNKNOWN SPOUSE OF MARVIN SARAQUSE; UNKNOWN SPOUSE OF DEBORAH K. SARAQUSE A/K/A DEBORAH K. SARAQUSE; UNKNOWN TENANT #1; UNKNOWN TENANT #2; ALL OTHER UNKNOWN PARTIES CLAIMING INTERESTS BY, THROUGH, UNDER, AND AGAINST A NAMED DEFENDANT(S) WHO ARE NOT KNOWN TO BE DEAD OR ALIVE, WHETHER SAME UNKNOWN PARTIES MAY CLAIM AN INTEREST AS SPOUSES, HEIRS, DEVISEES, GRANTEES, OR OTHER CLAIMANTS., Defendant(s).

TO: PAUL LAPLANT
Last Known Address: 4992 Germany Avenue
North Port, Florida 34288
Current Address: Unknown
Previous Address: Unknown
TO: UNKNOWN SPOUSE OF PAUL LAPLANT
Last Known Address: 4992 Germany Avenue
North Port, Florida 34288

Current Address: Unknown

Previous Address: Unknown

TO: ALL OTHER UNKNOWN PARTIES CLAIMING INTERESTS BY, THROUGH, UNDER, AND AGAINST A NAMED DEFENDANT(S) WHO ARE NOT KNOWN TO BE DEAD OR ALIVE, WHETHER SAME UNKNOWN PARTIES MAY CLAIM AN INTEREST AS SPOUSES, HEIRS, DEVISEES, GRANTEES, OR OTHER CLAIMANTS whose residence is unknown if he/she/they be living; and if he/she/they be dead, the unknown defendants who may be spouses, heirs, devisees, grantees, assignees, lienors, creditors, trustees, and all parties claiming an interest by, through, under or against the Defendants, who are not known to be dead or alive, and all parties having or claiming to have any right, title or interest in the property described in the mortgage being foreclosed herein

YOU ARE NOTIFIED that an action to foreclose a mortgage on the following property in Sarasota County, Florida:

LOT 21, BLOCK 949, 22ND ADDITION TO PORT CHARLOTTE I' ILED IN PLAT BOOK 14, PAGE 10, OF THE PUBLIC RECORDS OF SARASOTA COUNTY, FLORIDA.

This property is located at the Street address of: 4992 Germany Avenue, North Port, Florida 34288
YOU ARE REQUIRED to serve a copy of your written defenses on or before June 16th, 2014 a date which is within 30 days after the first publication, if any, on Elizabeth R. Wellborn, P.A., Plaintiff's Attorney, whose address is 350 Jim Moran Blvd., Suite 100,

Deerfield Beach, Florida 33442, and file the original with this Court either before service on Plaintiff's Attorney, or immediately thereafter; otherwise, a default will be entered against you for the relief demanded in the Complaint or Petition.

This Notice shall be published once a week for two consecutive weeks in the Business Observer.

If you are a person with a disability who needs any accommodation in order to participate in this proceeding, you are entitled, at no cost to you, to the provision of certain assistance. Please contact the Sarasota County Jury Office, P.O. Box 3079, Sarasota, Florida 34230-3079, (941)861-7400, at least seven (7) days before your scheduled court appearance, or immediately upon receiving this notification if the time before the scheduled appearance is less than seven (7) days; if you are hearing or voice impaired, call 711.

WITNESS my hand and the seal of the court on May 6th, 2014.

KAREN E. RUSHING
CLERK OF THE COURT
(COURT SEAL) By: L. Szymanski
Deputy Clerk

Attorney for Plaintiff:
Brian Streicher, Esq.
Arlisa Certain, Esq.
Elizabeth R. Wellborn, P.A.
350 Jim Moran Blvd.,
Suite 100
Deerfield Beach, FL 33442
Telephone: (954) 354-3544
Facsimile: (954) 354-3545
Primary email:
bstreicher@erlaw.com
Secondary email:
servicecomplete@erlaw.com
0719-50324
May 16, 23, 2014 14-02113S

SECOND INSERTION

NOTICE OF ACTION - CONSTRUCTIVE SERVICE IN THE CIRCUIT COURT OF THE TWELFTH JUDICIAL CIRCUIT OF FLORIDA IN AND FOR SARASOTA COUNTY

GENERAL JURISDICTION DIVISION

CASE NO. 2013 CA 001359 NC U.S. BANK NATIONAL ASSOCIATION AS TRUSTEE FOR LEHMAN XS TRUST, SERIES 2006-GP4, Plaintiff, vs.

MARGARITA GIRON, et. al. Defendant(s),

TO: MARGARITA GIRON and THE UNKNOWN SPOUSE OF MARGARITA GIRON

whose residence is unknown if he/she/they be living; and if he/she/they be dead, the unknown defendants who may be spouses, heirs, devisees, grantees, assignees, lienors, creditors, trustees, and all parties claiming an interest by, through, under or against the Defendants, who are not known to be dead or alive, and all parties having or claiming to have any right, title or interest in the property described in the mortgage being foreclosed herein.

YOU ARE HEREBY NOTIFIED that an action to foreclose a mortgage

on the following property:

UNIT 419, BENEVA RIDGE, A CONDOMINIUM, TOGETHER WITH AN UNDIVIDED INTEREST IN THE COMMON ELEMENTS APPURTENANT THERETO, ACCORDING TO THE DECLARATION OF CONDOMINIUM THEREOF, AS RECORDED IN OFFICIAL RECORDS BOOK 1140, AT PAGES 1097 THROUGH 1145, AND AS PER PLAT THEREOF, RECORDED IN CONDOMINIUM BOOK 9, PAGES 26,26A AND 26B OF THE PUBLIC RECORDS OF SARASOTA COUNTY, FLORIDA, TOGETHER WITH ANY AMENDMENTS THERETO. A/K/A 4001 BENEVA ROAD APT 419, SARASOTA, FL 34233-1042

has been filed against you and you are required to serve a copy of your written defenses, if any, to it on counsel for Plaintiff, whose address is 6409 Congress Avenue, Suite 100, Boca Raton, Florida 33487 on or before 6-16-2014 / (30 days from Date of First Publication of this Notice) and file the original with the clerk of this court either before service on Plaintiff's attorney or im-

mmediately thereafter; otherwise a default will be entered against you for the relief demanded in the complaint or petition filed herein.

If you are a person with a disability who needs any accommodation in order to participate in this proceeding, you are entitled, at no cost to you, to the provision of certain assistance. Please contact the Sarasota County Jury Office, P.O. Box 3079, Sarasota, Florida 34230-3079, (941)861-7400, at least seven (7) days before your scheduled court appearance, or immediately upon receiving this notification if the time before the scheduled appearance is less than seven (7) days; if you are hearing or voice impaired, call 711.

WITNESS my hand and the seal of this Court at Sarasota County, Florida, this 7 day of May, 2014.

KAREN E. RUSHING, CLERK
CLERK OF THE CIRCUIT COURT
(SEAL) BY: G. Kopinsky
DEPUTY CLERK

ROBERTSON, ANSCHUTZ, AND SCHNEID, PL
ATTORNEY FOR PLAINTIFF
6409 CONGRESS AVENUE,
SUITE 100
BOCA RATON, FL 33487
13-17505
May 16, 23, 2014 14-02131S

SECOND INSERTION

NOTICE OF ACTION IN THE CIRCUIT COURT OF THE TWELFTH JUDICIAL CIRCUIT IN AND FOR

SARASOTA COUNTY, FLORIDA

CASE NO.: 2011 CA 007343 NC

FEDERAL NATIONAL MORTGAGE ASSOCIATION, Plaintiff, vs.

ESTATE OF JAMES B. REID, PLAZA GARDENS CONDOMINIUM ASSOCIATION, INC., THOMAS MICHAEL REID A/K/A THOMAS M. REID, KATHRYN REID A/K/A KATHRYN ANN REID, BRIAN JAMES REID, MARJORIE WEIDMAN, MARGARET M. REID A/K/A MARGARET MARY REID, UNKNOWN HEIRS, BENEFICIARIES, DEVISEES, ASSIGNEES, LIENORS, CREDITORS, TRUSTEES AND ALL OTHERS WHO MAY CLAIM AN INTEREST IN THE ESTATE OF JAMES B. REID A/K/A JAMES BERNARD REID, DECEASED, UNKNOWN TENANT(S) IN POSSESSION #1 and #2, et al. Defendant(s).

TO: BRIAN JAMES REID (Last Known Address)
4862 DUNCAN COURT
STERING HEIGHTS, MI 48310
419 E THOMAS ST, APT 207,
SEATTLE, WA 98102
23786 CUSHING AVE
EASTPONTE, MI 48021
ESTATE OF JAMES B. REID (Last Known Address)
3700 SOUTH OSPREY AVENUE # 322 SARASOTA, FL 34239
UNKNOWN HEIRS, BENEFICIARIES, DEVISEES, ASSIGNEES, LIENORS, CREDITORS, TRUSTEES AND ALL OTHERS WHO MAY CLAIM AN INTEREST IN THE ESTATE OF JAMES B. REID A/K/A

JAMES BERNARD REID, DECEASED (Last Known Address)
3700 SOUTH OSPREY AVENUE, #322 SARASOTA, FL 34239

(Current Residence Unknown) if living, and ALL OTHER UNKNOWN PARTIES, including, if a named Defendant is deceased, the personal representatives, the surviving spouse, heirs, devisees, grantees, creditors, and all other parties claiming, by, through, under or against that Defendant, and all claimants, persons or parties, natural or corporate, or whose exact legal status is unknown, claiming under any of the above named or described Defendants

YOU ARE NOTIFIED that an action for Foreclosure of Mortgage on the following described property:

UNIT 322, THE PLAZA GARDENS, A CONDOMINIUM ACCORDING TO THE DECLARATION OF CONDOMINIUM RECORDED IN OFFICIAL RECORDS BOOK 1318, PAGE 376, AND AMENDMENTS THERETO, AND AS PER PLAT THEREOF, RECORDED IN CONDOMINIUM BOOK 12, PAGE 50, AND AMENDMENTS THERETO, OF THE PUBLIC RECORDS OF SARASOTA COUNTY, FLORIDA.

A/K/A: 3700 SOUTH OSPREY AVENUE, #322, SARASOTA, FL 34239.

has been filed against you and you are required to serve a copy of your written defenses, if any, to it on Brian L. Rosaler, Esquire, POPKIN & ROSALER, P.A., 1701 West Hillsboro Boulevard, Suite 400, Deerfield Beach, FL 33442., Attorney for Plaintiff, whose on or before June 16th, 2014 a date

which is within thirty (30) days after the first publication of this Notice in the Business Observer and file the original with the Clerk of this Court either before service on Plaintiff's attorney or immediately thereafter; otherwise, a default will be entered against you for the relief demanded in the complaint.

If you cannot afford an attorney, contact Gulfcoast Legal Services at 366-1746 or www.gulfcoastlegal.org, or Legal Aid of Manasota at 366-0038 or www.legalaidofmanasota.org. If you do not qualify for free legal assistance or do not know an attorney, you may email an attorney referral service (listed in phone book) or contact the Florida Bar Lawyer Referral Service at (800) 342-8011.

If you are a person with a disability who needs any accommodation in order to participate in this proceeding, you are entitled, at no cost to you, to the provision of certain assistance. Please contact the Sarasota County Jury Office, P.O. Box 3079, Sarasota, Florida 34230-3079, (941)861-7400, at least seven (7) days before your scheduled court appearance, or immediately upon receiving this notification if the time before the scheduled appearance is less than seven (7) days; if you are hearing or voice impaired, call 711.

WITNESS my hand and the seal of this Court this 9th day of May, 2014.

KAREN E. RUSHING
As Clerk of the Court
(SEAL) By: L. Szymanski
As Deputy Clerk

Brian L. Rosaler, Esquire
POPKIN & ROSALER, P.A.,
1701 West Hillsboro Boulevard,
Suite 400,
Deerfield Beach, FL 33442
Attorney for Plaintiff
11-31078
May 16, 23, 2014 14-02150S

SECOND INSERTION

NOTICE OF ACTION IN THE CIRCUIT COURT OF THE TWELFTH JUDICIAL CIRCUIT IN AND FOR SARASOTA COUNTY, FLORIDA

CIVIL DIVISION

CASE NO.: 58-2013-CA-008448 NC

DIVISION: C

ONEWEST BANK, F.S.B. Plaintiff, v.

THE UNKNOWN SPOUSE, HEIRS, BENEFICIARIES, DEVISEES, GRANTEES, ASSIGNEES, LIENORS, CREDITORS, TRUSTEES, AND ALL OTHER PARTIES CLAIMING AN INTEREST BY, THROUGH, UNDER OR AGAINST THE ESTATE OF RICHARD B. BROWN, DECEASED; WAYNE BROWN; TAMMY GONZALEZ; SANDRA AUXIER; LYNN BAVAREISS A/K/A LYNN PLUMLEE; UNITED STATES OF AMERICA, ACTING ON BEHALF OF THE SECRETARY OF HOUSING AND URBAN DEVELOPMENT; CLERK OF THE CIRCUIT COURT OF SARASOTA COUNTY, FLORIDA; STATE OF FLORIDA, DEPARTMENT OF REVENUE; STATE OF FLORIDA, DEPARTMENT OF HEALTH; LATASHA N. STEEN; EAST VILLAGE MASTER ASSOCIATION, INC.; VILLAGE RUN HOMEOWNERS ASSOCIATION, INC.; UNKNOWN TENANT #1; UNKNOWN TENANT #2; ALL OTHER UNKNOWN PARTIES CLAIMING INTERESTS BY, THROUGH, UNDER, AND AGAINST A NAMED DEFENDANT(S) WHO ARE NOT KNOWN TO BE DEAD OR ALIVE, WHETHER SAME UNKNOWN

PARTIES MAY CLAIM AN INTEREST AS SPOUSES, HEIRS, DEVISEES, GRANTEES, OR OTHER CLAIMANTS, Defendant(s),

TO: THE UNKNOWN SPOUSE, HEIRS, BENEFICIARIES, DEVISEES, GRANTEES, ASSIGNEES, LIENORS, CREDITORS, TRUSTEES, AND ALL OTHER PARTIES CLAIMING AN INTEREST BY, THROUGH, UNDER OR AGAINST THE ESTATE OF RICHARD B. BROWN, DECEASED

Current Address: Unknown
Last Known Address: 2443 Watts Way Sarasota, Florida 34234
Current Address: Unknown
Previous Address: 2256 Sophie Springer Lane Sarasota, Florida 34234

YOU ARE NOTIFIED that an action to foreclose a mortgage on the following property in Sarasota County, Florida:

LOT 4, EAST VILLAGE MODEL CENTER, AS PER PLAT THEREOF RECORDED IN PLAT BOOK 30, PAGE(S) 45, OF THE PUBLIC RECORDS OF SARASOTA COUNTY, FLORIDA.

This property is located at the Street address of: 2206 E. Village Court, Venice, Florida 34293

YOU ARE REQUIRED to serve a copy of your written defenses on or before June 16th, 2014 a date which is within 30 days after the first publication, if any, on Elizabeth R. Wellborn, P.A., Plaintiff's Attorney, whose address is 350 Jim Moran Blvd., Suite 100,

Deerfield Beach, Florida 33442, and file the original with this Court either before service on Plaintiff's Attorney, or immediately thereafter; otherwise, a default will be entered against you for the relief demanded in the Complaint or Petition.

This Notice shall be published once a week for two consecutive weeks in the Business Observer.

If you are a person with a disability who needs any accommodation in order to participate in this proceeding, you are entitled, at no cost to you, to the provision of certain assistance. Please contact the Sarasota County Jury Office, P.O. Box 3079, Sarasota, Florida 34230-3079, (941)861-7400, at least seven (7) days before your scheduled court appearance, or immediately upon receiving this notification if the time before the scheduled appearance is less than seven (7) days; if you are hearing or voice impaired, call 711.

WITNESS my hand and the seal of the court on May 6th, 2014.

KAREN E. RUSHING
CLERK OF THE COURT
(COURT SEAL) By: L. Szymanski
Deputy Clerk

Attorney for Plaintiff:
Jacqueline Gardiner, Esq.
Arlisa Certain, Esq.
Elizabeth R. Wellborn, P.A.
350 Jim Moran Blvd., Suite 100
Deerfield Beach, FL 33442
Telephone: (954) 354-3544
Facsimile: (954) 354-3545
Primary email:
jgardiner@erlaw.com
Secondary email:
servicecomplete@erlaw.com
2012-16190
May 16, 23, 2014 14-02114S

SECOND INSERTION

NOTICE OF ACTION
IN THE CIRCUIT COURT OF THE
TWELFTH JUDICIAL CIRCUIT
IN AND FOR SARASOTA COUNTY,
FLORIDA

CIVIL ACTION
CASE NO.: 2014 CA 002046 NC
DIVISION: A

U.S. BANK NATIONAL
ASSOCIATION, AS INDENTURE
TRUSTEE FOR HOMEBANC
MORTGAGE TRUST 2005-5,
MORTGAGE BACKED NOTES,
SERIES 2005-5,
Plaintiff, vs.
LISA HUNTER, et al,
Defendant(s).

TO:
CHERYL HAYSLIP
LAST KNOWN ADDRESS: 4631
Summerwind Drive #16
Sarasota, FL 34234
CURRENT ADDRESS: UNKNOWN
THE UNKNOWN SPOUSE OF
CHERYL HAYSLIP
LAST KNOWN ADDRESS: 4631
Summerwind Drive #16
Sarasota, FL 34234
CURRENT ADDRESS: UNKNOWN
ANY AND ALL UNKNOWN PAR-

TIES CLAIMING BY, THROUGH,
UNDER, AND AGAINST THE
HEREIN NAMED INDIVIDUAL
DEFENDANT(S) WHO ARE NOT
KNOWN TO BE DEAD OR ALIVE,
WHETHER SAID UNKNOWN PART-
TIES MAY CLAIM AN INTEREST
AS SPOUSES, HEIRS, DEVISEES,
GRANTEES, OR OTHER CLAIM-
ANTS
LAST KNOWN ADDRESS: UN-
KNOWN
CURRENT ADDRESS: UNKNOWN

YOU ARE NOTIFIED that an ac-
tion to foreclose a mortgage on the
following property in SARASOTA
County, Florida:

CONDOMINIUM PARCEL:
UNIT NO. 16, OF SUMMER
WIND, A CONDOMINIUM,
ACCORDING TO THE PLAT
THEREOF RECORDED IN
CONDOMINIUM PLAT BOOK
20, PAGES 49 AND 49A, AND
BEING FURTHER DESCRIBED
IN THAT CERTAIN DECLARA-
TION OF CONDOMINIUM RE-
CORDED IN OR. BOOK 1607,
PAGE 1617 THROUGH 1674 ET
SEQ., TOGETHER WITH SUCH

ADDITIONS AND AMEND-
MENTS TO SAID DECLARA-
TION AND CONDOMINIUM
PLAT AS FROM TIME TO TIME
MAY BE MADE AND TOGETH-
ER WITH AN UNDIVIDED
INTEREST IN THE COMMON
ELEMENTS APPURTENANT
THERE TO AS SET FORTH IN
SAID DECLARATION, AND
ANY AMENDMENTS THERE-
TO. ALL AS RECORDED IN
THE PUBLIC RECORDS OF
SARASOTA COUNTY, FLORI-
DA.

has been filed against you and you
are required to serve a copy of your
written defenses within 30 days af-
ter the first publication, if any, on
Ronald R Wolfe & Associates, P.L.,
Plaintiff's attorney, whose address is
4919 Memorial Highway, Suite 200,
Tampa, Florida 33634, and file the
original with this Court either be-
fore service on Plaintiff's attorney or
immediately thereafter; otherwise a
default will be entered against you
for the relief demanded in the Com-
plaint or petition.

This notice shall be published once

each week for two consecutive weeks in
the Business Observer.

If you are a person with a dis-
ability who needs any accommo-
dation in order to participate in
this proceeding, you are entitled,
at no cost to you, to the provi-
sion of certain assistance. Please
contact the Sarasota County Jury
Office, P.O. Box 3079, Sarasota,
Florida 34230-3079, (941)861-7400,
at least seven (7) days before your
scheduled court appearance, or im-
mediately upon receiving this noti-
fication if the time before the
scheduled appearance is less than
seven (7) days; if you are hearing
or voice impaired, call 711.

WITNESS my hand and the seal of
this Court on this 2 day of May, 2014.

Karen E. Rushing
Clerk of the Court
(SEAL) By: G. Kopinsky
As Deputy Clerk

Ronald R Wolfe & Associates, P.L.,
Plaintiff's Attorney,
P.O. Box 25018
Tampa, Florida 33622-5018
F14001351
May 16, 23, 2014 14-02116S

SECOND INSERTION

NOTICE OF ACTION
FORECLOSURE PROCEEDINGS -
PROPERTY
IN THE CIRCUIT COURT OF THE
TWELFTH JUDICIAL CIRCUIT
IN AND FOR

SARASOTA COUNTY, FLORIDA
CIVIL DIVISION

Case #: 2014-CA-001499-NC
Division: A

Green Tree Servicing LLC
Plaintiff, vs.-
Ronald A. Rispoli a/k/a Ronald
Rispoli; et al.
Defendant(s).

TO: Ronald A. Rispoli a/k/a Ronald
Rispoli; CURRENT ADDRESS UN-
KNOWN; LAST KNOWN ADDRESS,
1178 38th Street, Sarasota, FL 34234
and Unknown Spouse of Ronald A.
Rispoli a/k/a Ronald Rispoli; CUR-
RENT ADDRESS UNKNOWN; LAST
KNOWN ADDRESS, 1178 38th Street,
Sarasota, FL 34234

Residence unknown, if living, in-
cluding any unknown spouse of the
said Defendants, if either has remar-
ried and if either or both of said De-
fendants are dead, their respective
unknown heirs, devisees, grantees,
assignees, creditors, lienors, and trust-
ees, and all other persons claiming by,
through, under or against the named
Defendant(s); and the aforementioned
named Defendant(s) and such of the
aforementioned unknown Defendants
and such of the aforementioned un-
known Defendants as may be infants,
incompetents or otherwise not sui ju-
ris.

YOU ARE HEREBY NOTIFIED
that an action has been commenced to
foreclose a mortgage on the following
real property, lying and being and situ-
ated in Sarasota County, Florida, more
particularly described as follows:

LOT 19, BLOCK A, FORD SUB-
DIVISION, ACCORDING TO
THE PLAT THEREOF, RE-

CORDED IN PLAT BOOK 5,
PAGE 7, PUBLIC RECORDS
OF SARASOTA COUNTY,
FLORIDA.

more commonly known as 1178
38th Street, Sarasota, FL 34234.
This action has been filed against you
and you are required to serve a copy of
your written defense, if any, upon SHA-
PIRO, FISHMAN & GACHÉ LLP, At-
torneys for Plaintiff, whose address is
4630 Woodland Corporate Blvd., Suite
100, Tampa, FL 33614, within thirty
(30) days after the first publication of
this notice and file the original with the
clerk of this Court either before service
on Plaintiff's attorney or immediately
there after; otherwise a default will be
entered against you for the relief de-
manded in the Complaint.

If you are a person with a disability
who needs any accommodation in or-
der to participate in this proceeding,
you are entitled, at no cost to you, to the
provision of certain assistance. Please
contact the Sarasota County Jury Of-
fice, P.O. Box 3079, Sarasota, Florida
34230-3079, (941)861-7400, at least
seven (7) days before your scheduled
court appearance, or immediately upon
receiving this notification if the time
before the scheduled appearance is less
than seven (7) days; if you are hearing
or voice impaired, call 711.

WITNESS my hand and seal of this
Court on the 5th day of May, 2014.

Karen E. Rushing
Circuit and County Courts
(SEAL) By: L. Szymanski
Deputy Clerk

SHAPIRO, FISHMAN &
GACHÉ, LLP
Attorneys for Plaintiff
4630 Woodland Corporate Blvd.,
Suite 100,
Tampa, FL 33614
13-260931 FC01 GRR
May 16, 23, 2014 14-02110S

SECOND INSERTION

NOTICE OF ACTION
IN THE CIRCUIT COURT OF THE
TWELFTH JUDICIAL CIRCUIT
IN AND FOR

SARASOTA COUNTY,
FLORIDA
CIVIL ACTION
CASE NO.: 58-2010-CA-004143-NC
DIVISION: A

CHASE HOME FINANCE LLC
SUCCESSOR BY MERGER TO
CHASE MANHATTAN
MORTGAGE CORPORATION,
Plaintiff, vs.
GIDEON RECHNITZ, et al,
Defendant(s).

TO:
CYNTHIA J. FOUTS A/K/A CYN-
THIA J. COOK

LAST KNOWN ADDRESS: 2745
MELGERT PLACE
SARASOTA, FL 34235
CURRENT ADDRESS: UNKNOWN
ANY AND ALL UNKNOWN PART-
TIES CLAIMING BY, THROUGH,
UNDER, AND AGAINST THE
HEREIN NAMED INDIVIDUAL
DEFENDANT(S) WHO ARE NOT
KNOWN TO BE DEAD OR ALIVE,
WHETHER SAID UNKNOWN PART-
TIES MAY CLAIM AN INTEREST
AS SPOUSES, HEIRS, DEVISEES,
GRANTEES, OR OTHER CLAIM-
ANTS
LAST KNOWN ADDRESS: UN-
KNOWN

YOU ARE NOTIFIED that an ac-
tion to foreclose a mortgage on the fol-
lowing property in SARASOTA County,
Florida:

LOT 626, KENSINGTON PARK,
UNIT NO. 5, ACCORDING
TO THE PLAT THEREOF RE-
CORDED IN PLAT BOOK 11,
PAGES 9 AND 9A, OF THE PUB-
LIC RECORDS OF SARASOTA

COUNTY, FLORIDA.

has been filed against you and
you are required to serve a copy
of your written defenses within 30
days after the first publication, if
any, on Ronald R Wolfe & As-
sociates, P.L., Plaintiff's attorney,
whose address is 4919 Memorial
Highway, Suite 200, Tampa, Flori-
da 33634, and file the original
with this Court either before
service on Plaintiff's attorney or
immediately thereafter; otherwise a
default will be entered against you
for the relief demanded in the
Complaint or petition.

This notice shall be published once
each week for two consecutive weeks in
the Business Observer.

If you are a person with a dis-
ability who needs any accommoda-
tion in order to participate in this
proceeding, you are entitled, at no
cost to you, to the provision of
certain assistance. Please contact
the Sarasota County Jury Office,
P.O. Box 3079, Sarasota, Florida
34230-3079, (941)861-7400, at least
seven (7) days before your sched-
uled court appearance, or immedi-
ately upon receiving this notification
if the time before the scheduled
appearance is less than seven (7)
days; if you are hearing or voice
impaired, call 711.

WITNESS my hand and the seal of
this Court on this 2 day of May, 2014.

Karen E. Rushing
Clerk of the Court
(SEAL) By: C. Brandenburg
As Deputy Clerk

Ronald R Wolfe & Associates, P.L.,
Plaintiff's Attorney,
P.O. Box 25018
Tampa, Florida 33622-5018
F10021002
May 16, 23, 2014 14-02115S

SECOND INSERTION

NOTICE OF ACTION
IN THE CIRCUIT COURT OF THE
TWELFTH JUDICIAL CIRCUIT
IN AND FOR SARASOTA COUNTY,
FLORIDA

CASE NO.: 2014 CA 002132 NC
BANK OF AMERICA, N.A.,
Plaintiff, vs.

UNKNOWN HEIRS,
BENEFICIARIES, DEVISEES,
GRANTEES, ASSIGNEES,
LIENORS, CREDITORS,
TRUSTEES AND ALL OTHER
PARTIES CLAIMING AN
INTEREST BY, THROUGH,
UNDER OR AGAINST THE
ESTATE OF NEENIE EDSON et al.,
Defendant(s).

TO: Unknown Heirs, Beneficia-
ries, Devisees, Grantees, Assignees,
Lienors, Creditors, Trustees and all
other parties claiming an Interest By,
Through, Under or Against the Estate
of Neenie Edson

Last Known Residence: Unknown
YOU ARE HEREBY NOTIFIED
that an action to foreclose a mortgage
on the following property in SARASO-
TA County, Florida:

VILLA 31, CARIBBEAN VIL-
LAS, A CONDOMINIUM,
SECTION THREE, A CON-
DOMINIUM ACCORDING
TO THE DECLARATION OF
CONDOMINIUM RECORD-
ED IN OFFICIAL RECORDS
BOOK 654, PAGE 119 AND
AMENDMENTS THERETO
AND AS PER PLAT THEREOF,
RECORDED IN CONDOMIN-
IUM BOOK 1, PAGE 45, AND
AMENDMENTS THERETO,
OF THE PUBLIC RECORDS
OF SARASOTA COUNTY,

FLORIDA.

has been filed against you and you
are required to serve a copy of your
written defenses, if any, to it on ALDRIDGE |
CONNORS, LLP, Plaintiff's attorney,
at 1615 South Congress Avenue, Suite
200, Delray Beach, FL 33445 (Phone
Number: (561) 392-6391), within 30
days of the first date of publication of
this notice, and file the original with
the clerk of this court either before
6/16/2014 on Plaintiff's attorney or
immediately thereafter; otherwise a
default will be entered against you for
the relief demanded in the complaint
or petition.

If you are a person with a disabil-
ity who needs any accommodation in
order to participate in this proceed-
ing, you are entitled, at no cost to you,
to the provision of certain assistance.
Please contact the Sarasota County
Jury Office, P.O. Box 3079, Sarasota,
Florida 34230-3079, (941)861-7400,
at least seven (7) days before your
scheduled court appearance, or imme-
diately upon receiving this notification
if the time before the scheduled ap-
pearance is less than seven (7) days;
if you are hearing or voice impaired,
call 711.

Dated on May 2, 2014.
KAREN E. RUSHING
As Clerk of the Court
(SEAL) By: B. Daly
As Deputy Clerk

ALDRIDGE | CONNORS, LLP
Plaintiff's Attorney
1615 South Congress Avenue,
Suite 200,
Delray Beach, FL 33445
Phone Number: (561)-392-6391
1092-6541B
May 16, 23, 2014 14-02094S

SECOND INSERTION

NOTICE OF ACTION -
(Constructive Service-Property)
IN THE CIRCUIT COURT OF
THE 12th JUDICIAL CIRCUIT, IN
AND FOR SARASOTA COUNTY,
FLORIDA

GENERAL JURISDICTION
DIVISION

CASE NO. 2014 CA 002271 NC
THE BANK OF NEW YORK
MELLON F/K/A THE BANK
OF NEW YORK, AS TRUSTEE
FOR THE HOLDERS OF
THE CERTIFICATES, FIRST
HORIZON MORTGAGE PASS
THROUGH CERTIFICATES
SERIES FHAMS 2007-FA1,
BY FIRST HORIZON HOME
LOANS, A DIVISION OF FIRST
TENNESSEE BANK NATIONAL
ASSOCIATION, MASTER
SERVICER, IN ITS CAPACITY
AS AGENT FOR THE TRUSTEE
UNDER THE POOLING AND
SERVICING AGREEMENT,
PLAINTIFF, vs.

THE UNKNOWN HEIRS,
DEVISEES, GRANTEES,
ASSIGNEES, LIENORS,
CREDITORS, TRUSTEES,
PARTIES OR OTHER CLAIMANTS
CLAIMING BY, THROUGH,
UNDER OR AGAINST BRUCE
A. MASON AKA BRUCE ALLAN
MASON, ET AL.,
DEFENDANT(S),
TO: THE UNKNOWN HEIRS, DE-
VISEES, GRANTEES, ASSIGNEES,
LIENORS, CREDITORS, TRUSTEES,
PARTIES OR OTHER CLAIMANTS
CLAIMING BY, THROUGH, UNDER
OR AGAINST BRUCE A. MASON
AKA BRUCE ALLAN MASON
LAST KNOWN ADDRESS:
2207 WISTERIA ST, SARASOTA, FL
34239

YOU ARE HEREBY NOTIFIED
that an action to foreclose a mortgage
on the following real property, lying
and being and situated in Sarasota
County, Florida, more particularly de-
scribed as follows:
LOT 7 & THE WEST 28 FEET
OF LOT 8, BLOCK C, GREEN-
WICH SUBDIVISION, AC-
CORDING TO THE PLAT

THEREOF RECORDED IN
PLAT BOOK 2, PAGE 139, OF
THE PUBLIC RECORDS OF
SARASOTA COUNTY, FLOR-
IDA

COMMONLY KNOWN AS:
2207 Wisteria Street, Sarasota,
FL 34239

Attorney file number: 13-09277
has been filed against you and you
are required to serve a copy of your writ-
ten defense, if any, to it on Pendergast
& Morgan, P.A., the Plaintiff's attorney,
whose address is 115 Perimeter Center
Place, South Terraces Suite 1000,
Atlanta, Georgia 30346, by which is
within thirty (30) days of the first pub-
lication. Please file the original with the
Clerk of this Court either before service
on the Plaintiff's attorney or immedi-
ately thereafter; otherwise a default
will be entered against you for the relief
demanded in the Complaint.

This notice shall be published once a
week for two consecutive weeks in the
Business Observer.

If you are a person with a disability
who needs any accommodation in or-
der to participate in this proceeding,
you are entitled, at no cost to you, to the
provision of certain assistance. Please
contact the Sarasota County Jury Of-
fice, P.O. Box 3079, Sarasota, Florida
34230-3079, (941)861-7400, at least
seven (7) days before your scheduled
court appearance, or immediately upon
receiving this notification if the time
before the scheduled appearance is less
than seven (7) days; if you are hearing
or voice impaired, call 711.

WITNESS my hand and the seal of
this Court at Sarasota County, Florida,
on the 6th day of May, 2014.

Clerk Name: KAREN E. RUSHING
As Clerk, Circuit Court
Sarasota County, Florida
(SEAL) BY: L. Szymanski
As Deputy Clerk

Pendergast & Morgan, P.A.
The Plaintiff's attorney
115 Perimeter Center Place,
South Terraces, Suite 1000
Atlanta, Georgia 30346
13-09277
May 16, 23, 2014 14-02104S

SECOND INSERTION

NOTICE OF ACTION
FORECLOSURE PROCEEDINGS -
PROPERTY
IN THE CIRCUIT COURT OF THE
TWELFTH JUDICIAL CIRCUIT
IN AND FOR

SARASOTA COUNTY, FLORIDA
CIVIL DIVISION
Case #: 2014-CA-001319-NC
DIVISION: C

JPMorgan Chase Bank, National
Association
Plaintiff, vs.-
Unknown Heirs, Devisees,
Grantees, Assignees, Creditors,
Lienors, and Trustees of Florence
Veilleux, Deceased, and All Other
Persons Claiming by and Through,
Under, Against The Named
Defendant(s); et al.
Defendant(s).

TO: Unknown Heirs, Devisees, Grant-
ees, Assignees, Creditors, Lienors,
and Trustees of Florence Veilleux, De-
ceased, and All Other Persons Claiming
by and Through, Under, Against The
Named Defendant(s); CURRENT AD-
RESS UNKNOWN UNTIL GUAR-
DIAN AD LITEM IS APPOINTED.

Residence unknown, if living, in-
cluding any unknown spouse of the
said Defendants, if either has remar-
ried and if either or both of said De-
fendants are dead, their respective
unknown heirs, devisees, grantees,
assignees, creditors, lienors, and trust-
ees, and all other persons claiming by,
through, under or against the named
Defendant(s); and the aforementioned
named Defendant(s) and such of the
aforementioned unknown Defendants
as may be infants, incompetents or
otherwise not sui ju-
ris.

YOU ARE HEREBY NOTIFIED
that an action has been commenced to
foreclose a mortgage on the following
real property, lying and being and situ-
ated in Sarasota County, Florida, more
particularly described as follows:
LOT 174 AND THE NORTH
ONE-HALF (1/2) OF LOT
176, NOKOMIS MANOR NA-

TURE'S PARK SUBDIVISION,
AS PER PLAT THEREOF, ON
FILE AND OF RECORD IN
PLAT BOOK 2, PAGE 69, OF
THE CIRCUIT COURT OF
SARASOTA COUNTY, FLOR-
IDA.

more commonly known as 403
Pinewood Avenue, Nokomis, FL
34275.

This action has been filed against you
and you are required to serve a copy
of your written defense, if any, upon
SHAPIRO, FISHMAN & GACHÉ
LLP, Attorneys for Plaintiff, whose
address is 4630 Woodland Corporate
Blvd., Suite 100, Tampa, FL 33614,
within thirty (30) days after the first
publication of this notice and file the
original with the clerk of this Court
either before service on Plaintiff's at-
torney or immediately there after;
otherwise a default will be entered
against you for the relief demanded
in the Complaint.

If you are a person with a dis-
ability who needs any accommoda-
tion in order to participate in this
proceeding, you are entitled, at no
cost to you, to the provision of cer-
tain assistance. Please contact the
Sarasota County Jury Office, P.O. Box
3079, Sarasota, Florida 34230-3079,
(941)861-7400, at least seven (7) days
before your scheduled court appear-
ance, or immediately upon receiving
this notification if the time before
the scheduled appearance is less than
seven (7) days; if you are hearing or
voice impaired, call 711.

WITNESS my hand and seal of this
Court on the 7th day of May, 2014.

Karen E. Rushing
Circuit and County Courts
(SEAL) By: S. Erb
Deputy Clerk

SHAPIRO, FISHMAN &
GACHÉ, LLP
Attorneys for Plaintiff
4630 Woodland Corporate Blvd.,
Suite 100,
Tampa, FL 33614
13-269446 FC01 CHE
May 16, 23, 2014 14-02112S

SECOND INSERTION

NOTICE OF ACTION
FORECLOSURE PROCEEDINGS -
PROPERTY
IN THE CIRCUIT COURT OF THE
TWELFTH JUDICIAL CIRCUIT
IN AND FOR

SARASOTA COUNTY, FLORIDA
CIVIL DIVISION

Case #: 2012-CA-009270-NC
HSBC Bank USA, National
Association, as Trustee for GSAA
2005-5

Plaintiff, vs.-
Unknown Heirs, Devisees,
Grantees, Assignees, Creditors,
Lienors, and Trustees of Kay R.
Cooney, Deceased, and All Other
Persons Claiming by and Through,
Under, Against The Named
Defendant(s); et al.
Defendant(s).

TO: Unknown Heirs, Devisees, Grant-
ees, Assignees, Creditors, Lienors,
and Trustees of Kay R. Cooney, Deceased,
and All Other Persons Claiming by and
Through, Under, Against The Named
Defendant(s); et al.

Residence unknown, if living, in-
cluding any unknown spouse of the
said Defendants, if either has remar-
ried and if either or both of said De-
fendants are dead, their respective
unknown heirs, devisees, grantees,
assignees, creditors, lienors, and trust-
ees, and all other persons claiming by,
through, under or against the named
Defendant(s); and the aforementioned
named Defendant(s) and such of the
aforementioned unknown Defendants
and such of the aforementioned un-
known Defendants as may be infants,
incompetents or otherwise not sui ju-
ris.

YOU ARE HEREBY NOTIFIED
that an action has been commenced to
foreclose a mortgage on the following
real property, lying and being and situ-
ated in Sarasota County, Florida, more
particularly described as follows:

CONDOMINIUM UNIT 1106,
VISTAS ON BENEVA, A CON-
DOMINIUM, ACCORDING
TO THE DECLARATION OF
CONDOMINIUM THEREOF,
AS RECORDED IN INSTRU-
MENT NO. 2004132741, AND
AMENDMENTS THERETO,

AND ACCORDING TO THE
CONDOMINIUM PLAT
THEREOF, AS RECORDED IN
CONDOMINIUM BOOK 37,
PAGE 7, 7A-7E, AND AMEND-
MENTS THERETO, OF THE
PUBLIC RECORDS OF SARA-
SOTA COUNTY, FLORIDA.
TOGETHER WITH AN UN-
DIVIDED INTEREST IN THE
COMMON ELEMENTS AP-
PURTENANT THERETO.

more commonly known as 1833
Parakeet Way, Condo Unit 1106,
Sarasota, FL 34232.

This action has been filed against you
and you are required to serve a copy of
your written defense, if any, upon SHA-
PIRO, FISHMAN & GACHÉ LLP, At-
torneys for Plaintiff, whose address is
4630 Woodland Corporate Blvd., Suite
100, Tampa, FL 33614, within thirty
(30) days after the first publication of
this notice and file the original with the
clerk of this Court either before service
on Plaintiff's attorney or immediately
there after; otherwise a default will be
entered against you for the relief de-
manded in the Complaint.

If you are a person with a disability
who needs any accommodation in or-
der to participate in this proceeding,
you are entitled, at no cost to you, to the
provision of certain assistance. Please
contact the Sarasota County Jury Of-
fice, P.O. Box 3079, Sarasota, Florida
34230-3079, (941)861-7400, at least
seven (7) days before your scheduled
court appearance, or immediately upon
receiving this notification if the time
before the scheduled appearance is less
than seven (7) days; if you are hearing
or voice impaired, call 711.

WITNESS my hand and seal of this
Court on the 6th day of May, 2014.

Karen E. Rushing
Circuit and County Courts
(SEAL) By: L. Szymanski
Deputy Clerk

SHAPIRO, FISHMAN &
GACHÉ, LLP
Attorneys for Plaintiff
4630 Woodland Corporate Blvd.,
Suite 100,
Tampa, FL 33614
12-249505 FC01 WNI
May 16, 23, 2014 14-02111S

FOURTH INSERTION

NOTICE OF APPLICATION FOR
TAX DEED

Notice is hereby given that KIRK
TRENCHFIELD & PURIS ENVI-
RONMENTAL INC, the holder of the
certificate listed below, has filed said
certificate for a tax deed to be issued.
The certificate number and year of is-
sue, the description of the property,
and the names in which the property is
assessed are as follows:

Certificate Number: 5496.000
Year of Issuance: 2012
Tax Deed File #: 14-0026 TD

Description of Property: 0958066668
LOT 68 BLK 666 17TH ADD TO
PORT CHARLOTTE
Name in which the property is as-

sessed:
ANNE M FOX & THOMAS N FOX
All of said property being in the
County of Sarasota, State of Flori-
da. Unless the certificate is re-
deemed according to law, the prop-
erty described in the certificate will
be sold to the highest bidder at the
Sarasota County Court House,
2000 Main Street, Historic Court-
room, East Wing, Sarasota, Florida,
at 9:00 a.m. on the 3RD day of
JUNE, 2014.

Karen E. Rushing
Clerk Of The Circuit Court
Sarasota County, Florida
By: T. Lake, Deputy Clerk
Publication Dates: MAY 2, 9, 16, 23
2014

14-01873S

SECOND INSERTION

NOTICE OF SALE IN THE CIRCUIT COURT OF THE TWELFTH JUDICIAL CIRCUIT OF THE STATE OF FLORIDA, IN AND FOR SARASOTA COUNTY CIVIL DIVISION CASE NO.

58-2013-CA-005661-0000-NC GREEN TREE SERVICING LLC, Plaintiff, vs. PATRICIA B. LEWIS; UNKNOWN SPOUSE OF PATRICIA B. LEWIS; TIKI ON THE BAY CONDOMINIUM ASSOCIATION, INC.; UNKNOWN TENANT #1; UNKNOWN TENANT #2; Defendant(s)

Notice is hereby given that, pursuant to a Final Summary Judgment of Foreclosure entered on 04/21/2014 in the above-styled cause, in the Circuit Court of Sarasota County, Florida, the office of Karen E. Rushing clerk of the circuit court will sell the property situate in Sarasota County, Florida, described as:

Condominium Unit No. 12, TIKI ON THE BAY RESORT CONDOMINIUMS, according to the Declaration thereof, as recorded in Instrument No. 2004093817 and Condominium Plat Book 36, Page 50, both of the Public Records of Sarasota County, Florida.

at public sale, to the highest and best bidder, for cash, www.sarasota.realforeclose.com at 9:00 o'clock, A.M., on May 29, 2014

Any person claiming an interest in the surplus from the sale, if any, other than the property owner as of the date of the lis pendens, must file a claim within 60 days after the sale.

If you are a person with a disability who needs any accommodation in order to participate in this proceeding, you are entitled, at no cost to you, to the provision of certain assistance. Please contact the Sarasota County Jury Office, P.O. Box 3079, Sarasota, Florida 34230-3079, (941)861-7400, at least seven (7) days before your scheduled court appearance, or immediately upon receiving this notification if the time before the scheduled appearance is less than seven (7) days; if you are hearing or voice impaired, call 711.

ATTORNEY FOR PLAINTIFF
By /S/ Josh D. Donnelly
Josh D. Donnelly
Florida Bar #64788

Date: 05/08/2014
THIS INSTRUMENT PREPARED BY:
Law Offices Of Daniel C. Consuegra
9204 King Palm Drive
Tampa, FL 33619-1328
Phone: 813-915-8660
Attorneys for Plaintiff
133026
May 16, 23, 2014 14-02125S

SECOND INSERTION

NOTICE OF RESCHEDULED SALE IN THE CIRCUIT COURT OF THE TWELFTH JUDICIAL CIRCUIT IN AND FOR SARASOTA COUNTY, FLORIDA

CIVIL ACTION CASE NO.: 2009 CA 013833 NC DIVISION: C

NATIONSTAR MORTGAGE LLC, Plaintiff, vs. DENNER, ARNOLD L. et al, Defendant(s).

NOTICE IS HEREBY GIVEN Pursuant to an Order Rescheduling Foreclosure Sale dated on or about April 21, 2014, and entered in Case No. 2009 CA 013833 NC of the Circuit Court of the Twelfth Judicial Circuit in and for Sarasota County, Florida in which Nationstar Mortgage LLC, is the Plaintiff and Arnold L. Denner, Elaine V. Denner, JP Morgan Chase Bank, N.A., are defendants, the Sarasota County Clerk of the Circuit Court will sell to the highest and best bidder for cash in/on the Internet: www.sarasota.realforeclose.com, Sarasota County, Florida at 9:00am on the 3rd day of June, 2014, the following described property as set forth in said Final Judgment of Foreclosure: THE EAST 1/2 OF LOT 16965 AND ALL OF LOTS 16966 AND 16967, SOUTH VENICE, UNIT NO. 64, ACCORDING TO THE PLAT THEREOF, RECORDED IN PLAT BOOK 7, PAGE 41, OF THE PUBLIC RECORDS OF SARASOTA COUNTY, FLORIDA.

2960 VALENCIA RD, VENICE, FL 34293-3616

Any person claiming an interest in the surplus from the sale, if any, other than the property owner as of the date of the Lis Pendens must file a claim within 60 days after the sale.

If you are a person with a disability who needs any accommodation in order to participate in this proceeding, you are entitled, at no cost to you, to the provision of certain assistance. Please contact the Sarasota County Jury Office, P.O. Box 3079, Sarasota, Florida 34230-3079, (941)861-7400, at least seven (7) days before your scheduled court appearance, or immediately upon receiving this notification if the time before the scheduled appearance is less than seven (7) days; if you are hearing or voice impaired, call 711.

Albertelli Law
Attorney for Plaintiff
P.O. Box 23028
Tampa, FL 33623
(813) 221-4743
(813) 221-9171 facsimile
eService: servealaw@albertellilaw.com
JR- 10-63269
May 16, 23, 2014 14-02122S

SECOND INSERTION

NOTICE OF FORECLOSURE SALE IN THE CIRCUIT COURT OF THE TWELFTH JUDICIAL CIRCUIT IN AND FOR SARASOTA COUNTY, FLORIDA

GENERAL JURISDICTION DIVISION CASE NO. 2010 CA 000063 NC

DEUTSCHE BANK NATIONAL TRUST COMPANY, AS TRUSTEE FOR NOVASTAR MORTGAGE FUNDING TRUST, SERIES 2006-6, Plaintiff, vs.

ESTELLA WILSON; STANLEY H. SHELTON AKA STANLEY SHELTON; et. Al. Defendant(s).

NOTICE IS HEREBY GIVEN pursuant to a Final Judgment of Foreclosure dated June 10, 2013, and entered in 2010 CA 000063 NC of the Circuit Court of the TWELFTH Judicial Circuit in and for Sarasota County, Florida, wherein DEUTSCHE BANK NATIONAL TRUST COMPANY, AS TRUSTEE FOR NOVASTAR MORTGAGE FUNDING TRUST, SERIES 2006-6 is the Plaintiff and ESTELLA WILSON; STANLEY H. SHELTON AKA STANLEY SHELTON; CARMEN STINSON; THREE OAKS HOA, INC. are the Defendant(s). Karen Rushing as the Clerk of the Circuit Court will sell to the highest and best bidder for cash at www.sarasota.realforeclose.com, at 09:00 AM, on June 2, 2014, the following described property as set forth in said Final Judgment, to wit:

LOT 583 OF THREE OAKS, UNIT 2, ACCORDING TO THE PLAT THEREOF AS RECORDED IN PLAT BOOK 41, PAGE(S) 40, OF THE PUBLIC RECORDS OF SARASOTA COUNTY, FLORIDA.

Any person claiming an interest in the surplus from the sale, if any, other than the property owner as of the date of the lis pendens must file a claim within 60 days after the sale.

If you are a person with a disability who needs any accommodation in order to participate in this proceeding, you are entitled, at no cost to you, to the provision of certain assistance. Please contact the Sarasota County Jury Office, P.O. Box 3079, Sarasota, Florida 34230-3079, (941)861-7400, at least seven (7) days before your scheduled court appearance, or immediately upon receiving this notification if the time before the scheduled appearance is less than seven (7) days; if you are hearing or voice impaired, call 711.

Dated this 12 day of May, 2014.
By: Philip Jones
Florida Bar No.: 107721
Robertson, Anschutz & Schneid, PL
Attorneys for Plaintiff
6409 Congress Avenue, Suite 100
Boca Raton, Florida 33487
13-13957
May 16, 23, 2014 14-02203S

SECOND INSERTION

NOTICE OF RESCHEDULED FORECLOSURE SALE IN THE CIRCUIT COURT OF THE TWELFTH JUDICIAL CIRCUIT IN AND FOR SARASOTA COUNTY, FLORIDA

CIVIL ACTION CASE NO.: 2009-CA-017823-NC DIVISION: A

HSBC MORTGAGE SERVICES INC, Plaintiff, vs.

AMBER ELLIOTT, et al, Defendant(s).

NOTICE IS HEREBY GIVEN pursuant to an Order Rescheduling Foreclosure Sale dated May 8, 2014 and entered in Case No. 2009-CA-017823-NC of the Circuit Court of the TWELFTH Judicial Circuit in and for SARASOTA County, Florida wherein HSBC MORTGAGE SERVICES INC, is the Plaintiff and AMBER ELLIOTT; MICHAEL ELLIOTT; CITIFINANCIAL EQUITY SERVICES, INC. F/K/A COMMERCIAL CREDIT CONSUMER SERVICES, INC.; are the Defendants, The Clerk will sell to the highest and best bidder for cash at WWW.SARASOTA.REALFORECLOSE.COM at 9:00AM, on 06/12/2014, the following described property as set forth in said Final Judgment:

LOT 591, LAKE SARASOTA, UNIT NO. 7, ACCORDING TO THE PLAT THEREOF RECORDED IN PLAT BOOK 8, PAGE 88, OF THE PUBLIC RECORDS OF SARASOTA COUNTY, FLORIDA.

A/K/A 4179 WESTMINSTER DRIVE, SARASOTA, FL 34241

Any person claiming an interest in the surplus from the sale, if any, other than the property owner as of the date of the Lis Pendens must file a claim within sixty (60) days after the sale.

If you are a person with a disability who needs any accommodation in order to participate in this proceeding, you are entitled, at no cost to you, to the provision of certain assistance. Please contact the Sarasota County Jury Office, P.O. Box 3079, Sarasota, Florida 34230-3079, (941)861-7400, at least seven (7) days before your scheduled court appearance, or immediately upon receiving this notification if the time before the scheduled appearance is less than seven (7) days; if you are hearing or voice impaired, call 711.

By: Victoria S. Jones
Florida Bar No. 52252
Ronald R Wolfe & Associates, P.L.
P.O. Box 25018
Tampa, Florida 33622-5018
(813) 251-4766
(813) 251-1541 Fax
F09104804
May 16, 23, 2014 14-02153S

SECOND INSERTION

NOTICE OF SALE IN THE CIRCUIT COURT OF THE TWELFTH JUDICIAL CIRCUIT IN AND FOR SARASOTA COUNTY, FLORIDA

CIVIL ACTION CASE NO.: 2013 CA 001653 NC

NATIONSTAR MORTGAGE LLC, Plaintiff vs.

ROBERT J. FUESY, et al. Defendant(s)

Notice is hereby given that, pursuant to a Final Judgment of Foreclosure dated April 28, 2014, entered in Civil Case Number 2013 CA 001653 NC, in the Circuit Court for Sarasota County, Florida, wherein NATIONSTAR MORTGAGE LLC is the Plaintiff, and ROBERT J. FUESY, et al., are the Defendants, Sarasota County Clerk of Court will sell the property situated in Sarasota County, Florida, described as:

LOT 390, OVERBROOK GARDENS, UNIT 3, ACCORDING TO THE PLAT THEREOF RECORDED IN PLAT BOOK 10, PAGE 27, OF THE PUBLIC RECORDS OF SARASOTA COUNTY, FLORIDA.

at public sale, to the highest and best bidder, for cash, at www.sarasota.realforeclose.com at 09:00 AM, on the 12th day of June, 2014. Any person claiming an interest in the surplus from the sale, if any, other than the property owner as of the date of the lis pendens must file a claim within 60 days after the sale.

If you are a person with a disability who needs any accommodation in order to participate in this proceeding, you are entitled, at no cost to you, to the provision of certain assistance. Please contact the Sarasota County Jury Office, P.O. Box 3079, Sarasota, Florida 34230-3079, (941)861-7400, at least seven (7) days before your scheduled court appearance, or immediately upon receiving this notification if the time before the scheduled appearance is less than seven (7) days; if you are hearing or voice impaired, call 711.

Dated: May 8, 2014
By: /S/ Michael Feiner
Michael Feiner, Esquire (FBN 75051)
FLORIDA FORECLOSURE ATTORNEYS, PLLC
4855 Technology Way, Suite 500
Boca Raton, FL 33431
(727) 446-4826
emailservice@ffapllc.com
Our File No: CA12-02633 /CQ
May 16, 23, 2014 14-02127S

SECOND INSERTION

NOTICE OF FORECLOSURE SALE IN THE CIRCUIT COURT OF THE TWELFTH JUDICIAL CIRCUIT IN AND FOR SARASOTA COUNTY, FLORIDA

GENERAL JURISDICTION DIVISION CASE NO. 2011CA008951 NC

GMAC MORTGAGE, LLC, Plaintiff, vs.

LISA HOPKINS; et. Al. Defendant(s).

NOTICE IS HEREBY GIVEN pursuant to a Final Judgment of Foreclosure dated April 22, 2014, and entered in 2011CA008951 NC of the Circuit Court of the TWELFTH Judicial Circuit in and for Sarasota County, Florida, wherein GMAC MORTGAGE, LLC., is the Plaintiff and LISA HOPKINS; JP MORGAN CHASE BANK, NATIONAL ASSOCIATION; SYLVAN LEA ASSOCIATION, INC; TENANT #2 N/K/A JOHN SILVERSTEINE; TENANT #1 N/K/A COURTNEY DILLMAN are the Defendant(s). Karen Rushing as the Clerk of the Circuit Court will sell to the highest and best bidder for cash at www.sarasota.realforeclose.com, at 09:00 AM, on May 29, 2014, the following described property as set forth in said Final Judgment, to wit:

LOT 4, BLOCK A, SYLVAN LEA SUBDIVISION, AS PER PLAT THEREOF RECORDED IN PLAT BOOK 26, PAGES 22, 22A THROUGH 22C, OF THE PUBLIC RECORDS OF SARASOTA COUNTY, FLORIDA.

Any person claiming an interest in the surplus from the sale, if any, other than the property owner as of the date of the lis pendens must file a claim within 60 days after the sale.

If you are a person with a disability who needs any accommodation in order to participate in this proceeding, you are entitled, at no cost to you, to the provision of certain assistance. Please contact the Sarasota County Jury Office, P.O. Box 3079, Sarasota, Florida 34230-3079, (941)861-7400, at least seven (7) days before your scheduled court appearance, or immediately upon receiving this notification if the time before the scheduled appearance is less than seven (7) days; if you are hearing or voice impaired, call 711.

Dated this 8 day of May, 2014.
By: Philip Jones
Philip Jones
Florida Bar # 107721
Robertson, Anschutz & Schneid, PL
Attorneys for Plaintiff
6409 Congress Avenue,
Suite 100
Boca Raton, Florida 33487
13-17404
May 16, 23, 2014 14-02151S

SECOND INSERTION

NOTICE OF SALE IN THE CIRCUIT COURT OF THE TWELFTH JUDICIAL CIRCUIT IN AND FOR SARASOTA COUNTY, FLORIDA

CASE NO.: 58-2012-CA-009906 NC

THIRD FEDERAL SAVINGS AND LOAN ASSOCIATION OF CLEVELAND

Plaintiff vs. VERONICA A HICKEY; KEVIN R. HICKEY; SARASOTA COASTAL CREDIT UNION; BOARD OF COUNTY COMMISSIONERS.

Defendant(s)

NOTICE IS HEREBY GIVEN pursuant to an Order of Uniform Final Judgment of Mortgage Foreclosure dated January 6, 2014, entered in Civil Case No. 58-2012-CA-009906 NC of the Circuit Court of the Twelfth Judicial Circuit in and for Sarasota County, Florida, wherein the Clerk of the Circuit Court will sell to the highest bidder for cash on the 5th day of June, 2014, at 9:00 a.m. online at the website: https://www.sarasota.realforeclose.com, relative to the following described property as set forth in the Final Judgment, to wit:

Lots 44 and 45, Las Lomas De Sarasota, as per Plat thereof recorded in Plat Book 7, Page 34, of the Public Records of Sarasota County, Florida.

Any person claiming an interest in the surplus from the sale, if any, other than the property owner as of the date of the Lis Pendens must file a claim within 60 days after the sale.

If you are a person with a disability who needs any accommodation in order to participate in this proceeding, you are entitled, at no cost to you, to the provision of certain assistance. Please contact the Sarasota County Jury Office, P.O. Box 3079, Sarasota, Florida 34230-3079, (941)861-7400, at least seven (7) days before your scheduled court appearance, or immediately upon receiving this notification if the time before the scheduled appearance is less than seven (7) days; if you are hearing or voice impaired, call 711.

Dated: May 8, 2014
By: /S/ Michael Feiner
Michael Feiner, Esquire (FBN 75051)
FLORIDA FORECLOSURE ATTORNEYS, PLLC
4855 Technology Way, Suite 500
Boca Raton, FL 33431
(727) 446-4826
emailservice@ffapllc.com
Our File No: CA13-00468 /CQ
May 16, 23, 2014 14-02149S

SECOND INSERTION

NOTICE OF SALE IN THE CIRCUIT COURT OF THE TWELFTH JUDICIAL CIRCUIT OF THE STATE OF FLORIDA, IN AND FOR SARASOTA COUNTY CIVIL DIVISION CASE NO.

58-2013-CA-006612-0000-NC GREEN TREE SERVICING LLC, Plaintiff, vs.

ERNEST K. ALLEN; UNKNOWN SPOUSE OF ERNEST K. ALLEN; GINA ALLEN; UNKNOWN TENANT #1; UNKNOWN TENANT #2; Defendant(s)

Notice is hereby given that, pursuant to a Final Summary Judgment of Foreclosure entered on 04/21/2014 in the above styled cause, in the Circuit Court of Sarasota County, Florida, the office of Karen E. Rushing clerk of the circuit court will sell the property situate in Sarasota County, Florida, described as: LOT 39, BLOCK 405, 9TH ADDITION TO PORT CHARLOTTE SUBDIVISION, ACCORDING TO THE PLAT THEREOF, AS RECORDED IN PLAT BOOK 12, PAGE 21, 21A THROUGH 21S, OF THE PUBLIC RECORDS OF SARASOTA COUNTY, FLORIDA.

at public sale, to the highest and best bidder, for cash, www.sarasota.realforeclose.com at 9:00 o'clock, A.M., on May 29, 2014

Any person claiming an interest in the surplus from the sale, if any, other than the property owner as of the date of the lis pendens, must file a claim within 60 days after the sale.

If you are a person with a disability who needs any accommodation in order to participate in this proceeding, you are entitled, at no cost to you, to the provision of certain assistance. Please contact the Sarasota County Jury Office, P.O. Box 3079, Sarasota, Florida 34230-3079, (941)861-7400, at least seven (7) days before your scheduled court appearance, or immediately upon receiving this notification if the time before the scheduled appearance is less than seven (7) days; if you are hearing or voice impaired, call 711.

ATTORNEY FOR PLAINTIFF
By /S/ Josh D. Donnelly
Josh D. Donnelly
Florida Bar #64788

Date: 05/09/2014
THIS INSTRUMENT PREPARED BY:
Law Offices Of Daniel C. Consuegra
9204 King Palm Drive
Tampa, FL 33619-1328
Phone: 813-915-8660
Attorneys for Plaintiff
126263
May 16, 23, 2014 14-02146S

SECOND INSERTION

NOTICE OF SALE IN THE CIRCUIT COURT OF THE TWELFTH JUDICIAL CIRCUIT IN AND FOR SARASOTA COUNTY, FLORIDA

CIVIL ACTION CASE NO.: 2013 CA 002437 NC

U.S. BANK NATIONAL ASSOCIATION AS TRUSTEE FOR BS ABS 2005-AC6,

Plaintiff vs. JESSE J. LOY, et al. Defendant(s)

Notice is hereby given that, pursuant to a Final Judgment of Foreclosure dated April 28, 2014, entered in Civil Case Number 2013 CA 002437 NC, in the Circuit Court for Sarasota County, Florida, wherein U.S. BANK NATIONAL ASSOCIATION AS TRUSTEE FOR BS ABS 2005-AC6 is the Plaintiff, and JESSE J. LOY, et al., are the Defendants, Sarasota County Clerk of Court will sell the property situated in Sarasota County, Florida, described as:

Lot 2, Block 351, THIRD ADDITION TO PORT CHARLOTTE SUBDIVISION, a Subdivision, according to the Plat thereof as recorded in Plat Book 11, Pages 31, 31A-31D, of the Public Records of Sarasota County, Florida.

at public sale, to the highest and best bidder, for cash, at www.sarasota.realforeclose.com at 09:00 AM, on the 12th day of June, 2014. Any person claiming an interest in the surplus from the sale, if any, other than the property owner as of the date of the lis pendens must file a claim within 60 days after the sale.

If you are a person with a disability who needs any accommodation in order to participate in this proceeding, you are entitled, at no cost to you, to the provision of certain assistance. Please contact the Sarasota County Jury Office, P.O. Box 3079, Sarasota, Florida 34230-3079, (941)861-7400, at least seven (7) days before your scheduled court appearance, or immediately upon receiving this notification if the time before the scheduled appearance is less than seven (7) days; if you are hearing or voice impaired, call 711.

Dated: May 8, 2014
By: /S/ Michael Feiner
Michael Feiner, Esquire (FBN 75051)
FLORIDA FORECLOSURE ATTORNEYS, PLLC
4855 Technology Way, Suite 500
Boca Raton, FL 33431
(727) 446-4826
emailservice@ffapllc.com
Our File No: CA13-00468 /CQ
May 16, 23, 2014 14-02128S

SECOND INSERTION

NOTICE OF FORECLOSURE SALE IN THE CIRCUIT COURT OF THE TWELFTH JUDICIAL CIRCUIT IN AND FOR

SARASOTA COUNTY, FLORIDA CASE NO.: 2013 CA 008152 NC

FEDERAL NATIONAL MORTGAGE ASSOCIATION, Plaintiff, vs.

EUGENE VARIO A/K/A EUGENE C. VARIO, INDIVIDUALLY AND AS TRUSTEE OF THE

EUGENE C. VARIO REVOCABLE TRUST AGREEMENT DATED 02/22/2010; UNKNOWN SPOUSE OF EUGENE VARIO A/K/A

EUGENE C. VARIO; UNKNOWN BENEFICIARIES, TRUSTEES AND ALL OTHERS WHO MAY CLAIM AN INTEREST UNDER THE

EUGENE C. VARIO REVOCABLE TRUST AGREEMENT DATED 02/22/2010; BRANCH BANKING AND TRUST COMPANY, SUCCESSOR IN INTEREST TO

COLONIAL BANK, N.A.; BANK OF AMERICA, N.A.; FOXWOOD CONDOMINIUM ASSOCIATION, INC.; UNKNOWN TENANT(S) IN POSSESSION #1 and #2, and ALL OTHER UNKNOWN PARTIES, et. al.

Defendant(s).

NOTICE IS HEREBY GIVEN pursuant to a Final Summary Judgment of Foreclosure dated May 05, 2014, entered in Civil Case No.: 2013 CA 008152 NC of the Circuit Court of the Twelfth Judicial Circuit in and for Sarasota County, Florida, wherein FEDERAL NATIONAL MORTGAGE ASSOCIATION, Plaintiff, and EUGENE VARIO A/K/A EUGENE C. VARIO, INDIVIDUALLY AND AS TRUSTEE OF THE EUGENE C. VARIO REVOCABLE TRUST AGREEMENT DATED 02/22/2010; UNKNOWN BENEFICIARIES, TRUSTEES AND

ALL OTHERS WHO MAY CLAIM AN INTEREST UNDER THE EUGENE C. VARIO REVOCABLE TRUST AGREEMENT DATED 02/22/2010; BRANCH BANKING AND TRUST COMPANY, SUCCESSOR IN INTEREST TO COLONIAL BANK, N.A.; BANK OF AMERICA, N.A.; FOXWOOD CONDOMINIUM ASSOCIATION, INC.; and ALL OTHER UNKNOWN PARTIES, including, if a named Defendant is deceased, the personal representatives, the surviving spouse, heirs, devisees, grantees, creditors, and all other parties claiming, by, through, under or against that Defendant, and all claimants, persons or parties, natural or corporate, or whose exact legal status is unknown, claiming under any of the above named or described Defendants, are Defendants.

KAREN E. RUSHING, The Clerk of the Circuit Court, will sell to the highest bidder for cash, www.sarasota.realforeclose.com, at 09:00 AM, on the 6th day of June, 2014, the following described real property as set forth in said Final Summary Judgment, to wit:

UNIT 95, FOXWOOD CONDOMINIUM, A CONDOMINIUM ACCORDING TO THE DECLARATION OF CONDOMINIUM RECORDED IN OFFICIAL RECORDS BOOK 1665, PAGE 467, AND AMENDMENTS THERETO, AND AS PER PLAT THEREOF, RECORDED IN CONDOMINIUM BOOK 22, PAGE 7, AND AMENDMENTS THERETO, OF THE PUBLIC RECORDS OF SARASOTA COUNTY, FLORIDA

If you are a person claiming a right to funds remaining after the sale, you must file a claim with the clerk no later than 60 days after the sale. If you fail to file a claim you will not be entitled

to any remaining funds. After 60 days, only the owner of record as of the date of the lis pendens may claim the surplus.

If you cannot afford an attorney, contact Gulfoast Legal Services at (941)366-1746 or www.gulfoastlegal.org or Legal Aid of Manasota at (941)366-0038 or www.legalaidofmanasota.org. If you do not qualify for free legal assistance or do not know an attorney, you may call an attorney referral service (listed in the phone book), or contact the Florida Bar Lawyer Referral Service at (800)342-8011.

IF YOU ARE A PERSON WITH A DISABILITY WHO NEEDS ANY ACCOMMODATION IN ORDER TO PARTICIPATE IN THIS PROCEEDING, YOU ARE ENTITLED, AT NO COST TO YOU, TO THE PROVISION OF CERTAIN ASSISTANCE.

PLEASE CONTACT THE SARASOTA COUNTY JURY OFFICE, P.O. BOX 3079, SARASOTA, FLORIDA 34230-3079, (941)861-7400, AT LEAST SEVEN (7) DAYS BEFORE YOUR SCHEDULED COURT APPEARANCE, OR IMMEDIATELY UPON RECEIVING THIS NOTIFICATION IF THE TIME BEFORE THE SCHEDULED APPEARANCE IS LESS THAN SEVEN (7) DAYS; IF YOU ARE HEARING OR VOICE IMPAIRED, CALL 711.

Dated: 5/12/14
By: Corey M. Ohayon
Florida Bar No.: 0051323.

Attorney for Plaintiff:
Brian L. Rosaler, Esquire
Popkin & Rosaler, P.A.
1701 West Hillsboro Boulevard
Suite 400
Deerfield Beach, FL 33442
Telephone: (954) 360-9030
Facsimile: (954) 420-5187
13-37654
May 16, 23, 2014 14-02168S

SAVE TIME
E-mail your Legal Notice

legal@businessobserverfl.com

Business
Observer

SECOND INSERTION

NOTICE OF FORECLOSURE SALE IN THE CIRCUIT COURT OF THE TWELFTH JUDICIAL CIRCUIT IN AND FOR SARASOTA COUNTY, FLORIDA
CIVIL ACTION
CASE NO.: 2011-CA-004400-NC
DIVISION: A

PHH MORTGAGE CORPORATION, Plaintiff, vs. GAIL DOYLE A/K/A GAIL L. DOYLE, et al, Defendant(s).

NOTICE IS HEREBY GIVEN pursuant to a Final Judgment of Mortgage Foreclosure dated May 12, 2014 and entered in Case No. 2011-CA-004400-NC of the Circuit Court of the TWELFTH Judicial Circuit in and for SARASOTA County, Florida wherein PHH MORTGAGE CORPORATION is the Plaintiff and GAIL DOYLE A/K/A GAIL L. DOYLE; DARREN A DOYLE; VENTURA VILLAGE HOA, INC.; TENANT #1 N/K/A JOHN JOLLY, and TENANT #2 N/K/A TIFFANY JOLLY are the Defendants, The Clerk will sell to the highest and best bidder for cash at WWW.SARASOTA.REALFORECLOSE.COM at 9:00AM, on the 17th day of June, 2014, the following described property as set forth in said Final Judgment:

LOT 4113, VENTURA VILLAGE, UNIT 2, ACCORDING TO THE MAP OR PLAT THEREOF RECORDED IN PLAT BOOK 46, PAGES 28, 28A THRU 28E OF THE PUBLIC RECORDS OF SARASOTA COUNTY, FLORIDA

A/K/A 5144 LAYTON DRIVE, VENICE, FL 34293

Any person claiming an interest in the surplus from the sale, if any, other than the property owner as of the date of the Lis Pendens must file a claim within sixty (60) days after the sale.

If you are a person with a disability who needs any accommodation in order to participate in this proceeding, you are entitled, at no cost to you, to the provision of certain assistance. Please contact the Sarasota County Jury Office, P.O. Box 3079, Sarasota, Florida 34230-3079, (941)861-7400, at least seven (7) days before your scheduled court appearance, or immediately upon receiving this notification if the time before the scheduled appearance is less than seven (7) days; if you are hearing or voice impaired, call 711.

By: Lisa M. Lewis
Florida Bar No. 0086178
Ronald R Wolfe & Associates, P.L.
P.O. Box 25018
Tampa, Florida 33622-5018
(813) 251-4766
(813) 251-1541 Fax
F11007941
May 16, 23, 2014 14-02204S

SECOND INSERTION

NOTICE OF SALE IN THE CIRCUIT COURT OF THE TWELFTH JUDICIAL CIRCUIT IN AND FOR SARASOTA COUNTY, FLORIDA
CIVIL DIVISION
Case #: 2010-CA-011905-NC
DIVISION: C

Regions Bank d/b/a Regions Mortgage Plaintiff, -vs- Javier Curiel and Maria Estela Curiel a/k/a Maria Estela Curiel, Husband and Wife; Regions Bank d/b/a AmSouth Bank; The Woods Homeowners Association, Inc.; Defendant(s).

NOTICE IS HEREBY GIVEN pursuant to order rescheduling foreclosure sale or Final Judgment, entered in Civil Case No. 2010-CA-011905-NC of the Circuit Court of the 12th Judicial Circuit in and for Sarasota County, Florida, wherein Regions Bank d/b/a Regions Mortgage, Plaintiff and Javier Curiel and Maria Estela Curiel a/k/a Maria Estela Curiel, Husband and Wife are defendant(s), I, Clerk of Court, Karen E. Rushing, will sell to the highest and best bidder for cash VIA THE INTERNET AT WWW.SARASOTA.REALFORECLOSE.COM, AT 9:00 A.M. on June 12, 2014, the following described property as set forth in said Final Judgment, to-wit:

LOT 84, THE WOODS, UNIT 3, AS PER PLAT THEREOF, RECORDED IN PLAT BOOK 32, PAGES 17 AND 17A THROUGH 17D, INCLUSIVE, OF THE PUBLIC RECORDS OF SARASOTA COUNTY, FLORIDA.

ANY PERSON CLAIMING AN INTEREST IN THE SURPLUS FROM THE SALE, IF ANY, OTHER THAN THE PROPERTY OWNER AS OF THE DATE OF THE LIS PENDENS MUST FILE A CLAIM WITHIN 60 DAYS AFTER THE SALE.

If you are a person with a disability who needs any accommodation in order to participate in this proceeding, you are entitled, at no cost to you, to the provision of certain assistance. Please contact the Sarasota County Jury Office, P.O. Box 3079, Sarasota, Florida 34230-3079, (941)861-7400, at least seven (7) days before your scheduled court appearance, or immediately upon receiving this notification if the time before the scheduled appearance is less than seven (7) days; if you are hearing or voice impaired, call 711.

Submitted By:
ATTORNEY FOR PLAINTIFF:
SHAPIRO, FISHMAN & GACHÉ, LLP
2424 North Federal Highway,
Suite 360
Boca Raton, Florida 33431
(561) 998-6700
(561) 998-6707
10-190699 FC01 UPN
May 16, 23, 2014 14-02216S

SECOND INSERTION

NOTICE OF SALE IN THE CIRCUIT COURT OF THE TWELFTH JUDICIAL CIRCUIT IN AND FOR SARASOTA COUNTY, FLORIDA
CIVIL DIVISION
Case #: 2012-CA-000431-NC
DIVISION: A

Wells Fargo Bank, NA Plaintiff, -vs- Paul M. Moon a/k/a Paul Moon and Susan Moon, Husband and Wife; Wells Fargo Bank, N.A. Successor by Merger to Wachovia Bank, National Association Defendant(s).

NOTICE IS HEREBY GIVEN pursuant to order rescheduling foreclosure sale or Final Judgment, entered in Civil Case No. 2012-CA-000431-NC of the Circuit Court of the 12th Judicial Circuit in and for Sarasota County, Florida, wherein Wells Fargo Bank, NA, Plaintiff and Paul M. Moon a/k/a Paul Moon and Susan Moon, Husband and Wife are defendant(s), I, Clerk of Court, Karen E. Rushing, will sell to the highest and best bidder for cash VIA THE INTERNET AT WWW.SARASOTA.REALFORECLOSE.COM, AT 9:00 A.M. on June 12, 2014, the following described property as set forth in said Final Judgment, to-wit:

LOT 44, BLOCK 402, 10TH ADDITION TO PORT CHARLOTTE SUBDIVISION, A SUBDIVISION, ACCORDING TO THE PLAT THEREOF, RECORDED IN PLAT BOOK 12, PAGES 22, 22A THROUGH 22M, INCLUSIVE, OF THE PUBLIC RECORDS OF SARASOTA COUNTY, FLORIDA.

ANY PERSON CLAIMING AN INTEREST IN THE SURPLUS FROM THE SALE, IF ANY, OTHER THAN THE PROPERTY OWNER AS OF THE DATE OF THE LIS PENDENS MUST FILE A CLAIM WITHIN 60 DAYS AFTER THE SALE.

If you are a person with a disability who needs any accommodation in order to participate in this proceeding, you are entitled, at no cost to you, to the provision of certain assistance. Please contact the Sarasota County Jury Office, P.O. Box 3079, Sarasota, Florida 34230-3079, (941)861-7400, at least seven (7) days before your scheduled court appearance, or immediately upon receiving this notification if the time before the scheduled appearance is less than seven (7) days; if you are hearing or voice impaired, call 711.

Submitted By:
ATTORNEY FOR PLAINTIFF:
SHAPIRO, FISHMAN & GACHÉ, LLP
2424 North Federal Highway,
Suite 360
Boca Raton, Florida 33431
(561) 998-6700
(561) 998-6707
10-202044 FC01 WNI
May 16, 23, 2014 14-02218S

SECOND INSERTION

NOTICE OF SALE IN THE CIRCUIT COURT OF THE TWELFTH JUDICIAL CIRCUIT IN AND FOR SARASOTA COUNTY, FLORIDA
CIVIL DIVISION
Case #: 2010-CA-000197-NC
DIVISION: C

JPMorgan Chase Bank, National Association Plaintiff, -vs- Julie Marie Abdilla a/k/a Julie Marie Ignagni a/k/a Julie M. Ignagni a/k/a Julie Ignagni; John Edward Ignagni a/k/a John E. Ignagni a/k/a John Ignagni; Marilyn Abdilla; Citicorp Trust Bank, FSB f/k/a Travelers Bank & Trust, FSB; JPMorgan Chase Bank, National Association; Melinda A. Delpech, P.A.; Defendant(s).

NOTICE IS HEREBY GIVEN pursuant to order rescheduling foreclosure sale or Final Judgment, entered in Civil Case No. 2010-CA-000197-NC of the Circuit Court of the 12th Judicial Circuit in and for Sarasota County, Florida, wherein JPMorgan Chase Bank, National Association, Plaintiff and Julie Marie Abdilla a/k/a Julie Marie Ignagni a/k/a Julie M. Ignagni a/k/a Julie Ignagni are defendant(s), I, Clerk of Court, Karen E. Rushing, will sell to the highest and best bidder for cash VIA THE INTERNET AT WWW.SARASOTA.REALFORECLOSE.COM, AT 9:00 A.M. on June 25, 2014, the following described property as set forth in said Final Judgment, to-wit:

LOT 93, TRACT A, LAKEWOOD, UNIT 1, ACCORDING TO THE PLAT THEREOF, AS RECORDED IN PLAT BOOK 8, PAGE 79, OF THE PUBLIC RECORDS OF SARASOTA COUNTY, FLORIDA.

ANY PERSON CLAIMING AN INTEREST IN THE SURPLUS FROM THE SALE, IF ANY, OTHER THAN THE PROPERTY OWNER AS OF THE DATE OF THE LIS PENDENS MUST FILE A CLAIM WITHIN 60 DAYS AFTER THE SALE.

If you are a person with a disability who needs any accommodation in order to participate in this proceeding, you are entitled, at no cost to you, to the provision of certain assistance. Please contact the Sarasota County Jury Office, P.O. Box 3079, Sarasota, Florida 34230-3079, (941)861-7400, at least seven (7) days before your scheduled court appearance, or immediately upon receiving this notification if the time before the scheduled appearance is less than seven (7) days; if you are hearing or voice impaired, call 711.

Submitted By:
ATTORNEY FOR PLAINTIFF:
SHAPIRO, FISHMAN & GACHÉ, LLP
2424 North Federal Highway,
Suite 360
Boca Raton, Florida 33431
(561) 998-6700
(561) 998-6707
09-164182 FC01 W50
May 16, 23, 2014 14-02215S

SECOND INSERTION

NOTICE OF FORECLOSURE SALE PURSUANT TO CHAPTER 45 IN THE CIRCUIT COURT OF THE TWELFTH JUDICIAL CIRCUIT IN AND FOR SARASOTA COUNTY, FLORIDA

CASE NO. 2009-CA-018325-NC
BRANCH BANKING AND TRUST COMPANY Plaintiff(s), vs. JASON IRVIN; et al., Defendant(s).

NOTICE IS HEREBY GIVEN that Sale will be made pursuant to an Order or Final Summary Judgment. Final Judgment was awarded on April 11, 2014 in Civil Case No.: 2009-CA-018325-NC, of the Circuit Court of the TWELFTH Judicial Circuit in and for SARASOTA County, Florida, wherein, BRANCH BANKING AND TRUST COMPANY is the Plaintiff, and, JASON IRVIN; KEELY IRVIN; LAKESIDE PLANTATION HOA, INC.; AND UNKNOWN TENANT(S) IN POSSESSION are Defendants.

The clerk of the court, Karen E. Rushing, will sell to the highest bidder for cash online at www.sarasota.realforeclose.com at 9:00 AM on May 30, 2014, the following described real property as set forth in said Final summary Judgment, to wit:

LOT 40, BLOCK 11, SECOND REPLAT OF LAKESIDE PLANTATION, ACCORDING TO THE PLAT THEREOF, AS RECORDED IN PLAT BOOK 41, PAGES 42 AND 42A, OF THE PUBLIC RECORDS OF SARASOTA COUNTY, FLORIDA.

ANY PERSON CLAIMING AN INTEREST IN THE SURPLUS FROM THE SALE, IF ANY, OTHER THAN THE PROPERTY OWNER AS OF THE DATE OF THE LIS PENDENS MUST FILE A CLAIM WITHIN 60 DAYS AFTER THE SALE.

If you are a person with a disability who needs any accommodation in order to participate in this proceeding, you are entitled, at no cost to you, to the provision of certain assistance. Please contact the Sarasota County Jury Office, P.O. Box 3079, Sarasota, Florida 34230-3079, (941)861-7400, at least seven (7) days before your scheduled court appearance, or immediately upon receiving this notification if the time before the scheduled appearance is less than seven (7) days; if you are hearing or voice impaired, call 711.

Dated this 13 day of MAY, 2014.
BY: Nalini Singh
Fla. Bar #43700
Aldridge Connors, LLP
Attorney for Plaintiff(s)
1615 South Congress Avenue,
Suite 200
Delray Beach, FL 33445
Phone: 561.392.6391
Fax: 561.392.6965
Primary E-Mail:
ServiceMail@aclawllp.com
1175-2720B
May 16, 23, 2014 14-02211S

SECOND INSERTION

NOTICE OF FORECLOSURE SALE PURSUANT TO CHAPTER 45 IN THE CIRCUIT COURT OF THE TWELFTH JUDICIAL CIRCUIT IN AND FOR SARASOTA COUNTY, FLORIDA

CASE NO. 2010-CA-001162 NC
WACHOVIA MORTGAGE, FSB. F.K.A. WORLD SAVINGS BANK Plaintiff(s), vs. EDMUND ARSENAULT JR.; et al., Defendant(s).

NOTICE IS HEREBY GIVEN that Sale will be made pursuant to an Order or Final Summary Judgment. Final Judgment was awarded on February 26, 2014 in Civil Case No.: 2010-CA-001162 NC, of the Circuit Court of the TWELFTH Judicial Circuit in and for SARASOTA County, Florida, wherein, WACHOVIA MORTGAGE, FSB. F.K.A. WORLD SAVINGS BANK, is the Plaintiff, and, EDMUND L. ARSENAULT, JR.; KATHLEEN T. ARSENAULT; ARGENT MORTGAGE COMPANY, LLC; AND UNKNOWN TENANT(S) IN POSSESSION are Defendants.

The clerk of the court, Karen E. Rushing, will sell to the highest bidder for cash online at www.sarasota.realforeclose.com at 9:00 AM on June 3, 2014, the following described real property as set forth in said Final summary Judgment, to wit:

THE SOUTH 100 FEET OF LOTS 5 AND 6, BLOCK D, SINGLE-TARY SUBDIVISION OF PALMER SUBDIVISION, AS PER PLAT THEREOF RECORDED IN PLAT BOOK 2, PAGE 73, OF THE PUBLIC RECORDS OF SARASOTA COUNTY, FLORIDA.

ANY PERSON CLAIMING AN INTEREST IN THE SURPLUS FROM THE SALE, IF ANY, OTHER THAN THE PROPERTY OWNER AS OF THE DATE OF THE LIS PENDENS MUST FILE A CLAIM WITHIN 60 DAYS AFTER THE SALE.

If you are a person with a disability who needs any accommodation in order to participate in this proceeding, you are entitled, at no cost to you, to the provision of certain assistance. Please contact the Sarasota County Jury Office, P.O. Box 3079, Sarasota, Florida 34230-3079, (941)861-7400, at least seven (7) days before your scheduled court appearance, or immediately upon receiving this notification if the time before the scheduled appearance is less than seven (7) days; if you are hearing or voice impaired, call 711.

Dated this 13 day of MAY, 2014.
BY: Nalini Singh
Fla. Bar #43700
Aldridge Connors, LLP
Attorney for Plaintiff(s)
1615 South Congress Avenue,
Suite 200
Delray Beach, FL 33445
Phone: 561.392.6391
Fax: 561.392.6965
Primary E-Mail:
ServiceMail@aclawllp.com
1175-2720B
May 16, 23, 2014 14-02212S

SECOND INSERTION

NOTICE OF SALE IN THE CIRCUIT COURT OF THE TWELFTH JUDICIAL CIRCUIT IN AND FOR SARASOTA COUNTY, FLORIDA

CASE NO. 2013 CA 001088 NC
WELLS FARGO BANK, N.A. Plaintiff, v. ANDREA BARRETT A/K/A ANDREA L. BARRETT; UNKNOWN SPOUSE OF ANDREA BARRETT A/K/A ANDREA L. BARRETT; UNKNOWN TENANT 1; UNKNOWN TENANT 2; AND ALL UNKNOWN PARTIES CLAIMING BY, THROUGH, UNDER OR AGAINST THE ABOVE NAMED DEFENDANT(S), WHO (IS/ARE) NOT KNOWN TO BE DEAD OR ALIVE, WHETHER SAID UNKNOWN PARTIES CLAIM AS HEIRS, DEVISEES, GRANTEEES, ASSIGNEES, LIENORS, CREDITORS, TRUSTEES, SPOUSES, OR OTHER CLAIMANTS; HIDDEN LAKE VILLAGE OF SARASOTA, INC. Defendants.

Notice is hereby given that, pursuant to the Summary Final Judgment of Foreclosure entered on December 16, 2013, and the Order Rescheduling Foreclosure Sale entered on APRIL 21, 2014, in this cause, in the Circuit Court of Sarasota County, Florida, the clerk shall sell the property situated in Sarasota County, Florida, described as:

UNIT NO. 2612-C, HIDDEN LAKE VILLAGE, A CONDOMINIUM, ALL IN ACCORDANCE WITH AND SUBJECT TO THE COVENANTS, CONDITIONS, RESTRICTIONS, TERMS AND OTHER PROVISIONS OF THE DECLARATION OF CONDOMINIUM OF HIDDEN LAKE VILLAGE, RECORDED IN OFFICIAL RECORDS BOOK 1368, PAGES 1482 THROUGH 1546, INCLUSIVE, AS AMENDED AND SUPPLEMENTED AND AS SHOWN BY THE PLOT PLANS OF THE CONDOMINIUM RECORDED IN CONDOMINIUM PLAT BOOK 14, PAGES 16 THROUGH 16-H, INCLUSIVE, AND AS THEREAFTER AMENDED, OF THE PUBLIC RECORDS OF SARASOTA COUNTY, FLORIDA.

PLEMENTED AND AS SHOWN BY THE PLOT PLANS OF THE CONDOMINIUM RECORDED IN CONDOMINIUM PLAT BOOK 14, PAGES 16 THROUGH 16-H, INCLUSIVE, AND AS THEREAFTER AMENDED, OF THE PUBLIC RECORDS OF SARASOTA COUNTY, FLORIDA.

a/k/a 2612 HIDDEN LAKE DR. N. UNIT C, SARASOTA, FL 34237-4554

at public sale, to the highest and best bidder, for cash, online at www.sarasota.realforeclose.com, on JUNE 03, 2014 beginning at 09:00 AM.

If you are a person claiming a right to funds remaining after the sale, you must file a claim with the clerk no later than 60 days after the sale. If you fail to file a claim you will not be entitled to any remaining funds.

If you are a person with a disability who needs any accommodation in order to participate in this proceeding, you are entitled, at no cost to you, to the provision of certain assistance. Please contact the Sarasota County Jury Office, P.O. Box 3079, Sarasota, Florida 34230-3079, (941)861-7400, at least seven (7) days before your scheduled court appearance, or immediately upon receiving this notification if the time before the scheduled appearance is less than seven (7) days; if you are hearing or voice impaired, call 711.

Dated at St. Petersburg, Florida, this 13th day of MAY, 2014.
By: TARA MCDONALD
FBN 43941
Douglas C. Zahm, P.A.
Designated Email Address:
efiling@dczahm.com
12425 28th Street North, Suite 200
St. Petersburg, FL 33716
Telephone No. (727) 536-4911
Attorney for the Plaintiff
888123038
May 16, 23, 2014 14-02205S

SECOND INSERTION

NOTICE OF SALE IN THE CIRCUIT COURT OF THE TWELFTH JUDICIAL CIRCUIT IN AND FOR SARASOTA COUNTY, FLORIDA
CIVIL DIVISION
Case #: 2011-CA-005455-NC
DIVISION: A

Wells Fargo Bank, National Association Plaintiff, -vs- Joann B. Ballis; Unknown Tenants in Possession #1, If living, and all Unknown Parties claiming by, through, under and against the above named Defendant(s) who are not known to be dead or alive, whether said Unknown Parties may claim an interest as Spouse, Heirs, Devisees, Grantees, or Other Claimants; Unknown Tenants in Possession #2, If living, and all Unknown Parties claiming by, through, under and against the above named Defendant(s) who are not known to be dead or alive, whether said Unknown Parties may claim an interest as Spouse, Heirs, Devisees, Grantees, or Other Claimants Defendant(s).

NOTICE IS HEREBY GIVEN pursuant to order rescheduling foreclosure sale or Final Judgment, entered in Civil Case No. 2011-CA-005455-NC of the Circuit Court of the 12th Judicial Circuit in and for Sarasota County, Florida, wherein Wells Fargo Bank, National Association, Plaintiff and Joann B. Ballis are defendant(s), I, Clerk of Court, Karen E. Rushing, will sell to the highest and best bidder for cash VIA THE INTERNET AT WWW.SARASOTA.REALFORECLOSE.COM, AT 9:00 A.M. on June 26, 2014, the following described property as set forth in said Final Judgment, to-wit:

LOT 1, BLOCK 1051, 24TH ADDITION TO PORT CHARLOTTE SUBDIVISION, A SUBDIVISION, ACCORDING TO THE PLAT THEREOF, AS RECORDED IN PLAT BOOK 14, PAGE 14, OF THE PUBLIC RECORDS OF SARASOTA COUNTY, FLORIDA.

ANY PERSON CLAIMING AN INTEREST IN THE SURPLUS FROM THE SALE, IF ANY, OTHER THAN THE PROPERTY OWNER AS OF THE DATE OF THE LIS PENDENS MUST FILE A CLAIM WITHIN 60 DAYS AFTER THE SALE.

If you are a person with a disability who needs any accommodation in order to participate in this proceeding, you are entitled, at no cost to you, to the provision of certain assistance. Please contact the Sarasota County Jury Office, P.O. Box 3079, Sarasota, Florida 34230-3079, (941)861-7400, at least seven (7) days before your scheduled court appearance, or immediately upon receiving this notification if the time before the scheduled appearance is less than seven (7) days; if you are hearing or voice impaired, call 711.

Submitted By:
ATTORNEY FOR PLAINTIFF:
SHAPIRO, FISHMAN & GACHÉ, LLP
2424 North Federal Highway,
Suite 360
Boca Raton, Florida 33431
(561) 998-6700
(561) 998-6707
10-206227 FC01 WNI
May 16, 23, 2014 14-02217S

SECOND INSERTION

NOTICE OF FORECLOSURE SALE PURSUANT TO CHAPTER 45 IN THE CIRCUIT COURT OF THE TWELFTH JUDICIAL CIRCUIT IN AND FOR SARASOTA COUNTY, FLORIDA

CASE NO. 2012 CA 007207 NC
WELLS FARGO BANK, NA, Plaintiff(s), vs. JOHN H. SHUGRUE; et al., Defendant(s).

NOTICE IS HEREBY GIVEN that Sale will be made pursuant to an Order or Final Summary Judgment. Final Judgment was awarded on April 22, 2014 in Civil Case No.: 2012 CA 007207 NC, of the Circuit Court of the TWELFTH Judicial Circuit in and for SARASOTA County, Florida, wherein, WELLS FARGO BANK, NA, is the Plaintiff, and, JOHN H. SHUGRUE; UNKNOWN SPOUSE OF JOHN H. SHUGRUE N/K/A MICHELLE SHUGRUE; CASTEL DEL MARE CONDOMINIUM ASSOCIATION, INC; UNKNOWN TENANT #1 N/K/A RYAN REN; AND UNKNOWN TENANT(S) IN POSSESSION are Defendants.

The clerk of the court, Karen E. Rushing, will sell to the highest bidder for cash online at www.sarasota.realforeclose.com at 9:00 AM on May 29, 2014, the following described real property as set forth in said Final summary Judgment, to wit:
UNIT 1658-202, BUILDING 8, CASTEL DEL MARE, A CONDOMINIUM ACCORDING TO THE DECLARATION OF CONDOMINIUM RECORDED IN OFFICIAL RECORDS BOOK 1088 PAGE 1305, AND AMEND-

MENTS THERETO, AND AS PER PLAT THEREOF RECORDED IN CONDOMINIUM BOOK 8, PAGES 44, AND AMENDMENTS THERETO, OF THE PUBLIC RECORDS OF SARASOTA COUNTY, FLORIDA.

ANY PERSON CLAIMING AN INTEREST IN THE SURPLUS FROM THE SALE, IF ANY, OTHER THAN THE PROPERTY OWNER AS OF THE DATE OF THE LIS PENDENS MUST FILE A CLAIM WITHIN 60 DAYS AFTER THE SALE.

If you are a person with a disability who needs any accommodation in order to participate in this proceeding, you are entitled, at no cost to you, to the provision of certain assistance. Please contact the Sarasota County Jury Office, P.O. Box 3079, Sarasota, Florida 34230-3079, (941)861-7400, at least seven (7) days before your scheduled court appearance, or immediately upon receiving this notification if the time before the scheduled appearance is less than seven (7) days; if you are hearing or voice impaired, call 711.

Dated this 13 day of MAY, 2014.
BY: Nalini Singh
Fla. Bar #43700
Aldridge Connors, LLP
Attorney for Plaintiff(s)
1615 South Congress Avenue,
Suite 200
Delray Beach, FL 33445
Phone: 561.392.6391
Fax: 561.392.6965
Primary E-Mail:
ServiceMail@aclawllp.com
1113-600927
May 16, 23, 2014 14-02213S

SAVE TIME
E-mail your Legal Notice

legal@businessobserverfl.com
Wednesday Noon Deadline • Friday Publication

Business Observer
LV4681

SECOND INSERTION

NOTICE OF SALE IN THE CIRCUIT COURT OF THE TWELFTH JUDICIAL CIRCUIT IN AND FOR SARASOTA COUNTY, FLORIDA
CIVIL DIVISION
Case #: 2010-CA-007268-NC
DIVISION: A

CitiMortgage, Inc.

Plaintiff, vs.-
Steven Lee Glashow; Fifth Third Bank, as Successor-in-Interest to West Coast Bank; Defendant(s).

NOTICE IS HEREBY GIVEN pursuant to order rescheduling foreclosure sale or Final Judgment, entered in Civil Case No. 2010-CA-007268-NC of the Circuit Court of the 12th Judicial Circuit in and for Sarasota County, Florida, wherein CitiMortgage, Inc., Plaintiff and Steven Lee Glashow are defendant(s), I, Clerk of Court, Karen E. Rushing, will sell to the highest and best bidder for cash VIA THE INTERNET AT WWW.SARASOTA.REALFORECLOSE.COM, AT 9:00 A.M. on June 12, 2014, the following described property as set forth in said Final Judgment, to-wit:

LOTS 338, 339 AND NORTHERLY 10 FEET OF LOT 340, CRESTLINE, ACCORDING TO THE PLAT THEREOF, AS RECORDED IN PLAT BOOK

2, PAGE 71, OF THE PUBLIC RECORDS OF SARASOTA COUNTY, FLORIDA.

ANY PERSON CLAIMING AN INTEREST IN THE SURPLUS FROM THE SALE, IF ANY, OTHER THAN THE PROPERTY OWNER AS OF THE DATE OF THE LIS PENDENS MUST FILE A CLAIM WITHIN 60 DAYS AFTER THE SALE.

If you are a person with a disability who needs any accommodation in order to participate in this proceeding, you are entitled, at no cost to you, to the provision of certain assistance. Please contact the Sarasota County Jury Office, P.O. Box 3079, Sarasota, Florida 34230-3079, (941)861-7400, at least seven (7) days before your scheduled court appearance, or immediately upon receiving this notification if the time before the scheduled appearance is less than seven (7) days; if you are hearing or voice impaired, call 711.

Submitted By:
ATTORNEY FOR PLAINTIFF:
SHAPIRO, FISHMAN
& GACHÉ, LLP

2424 North Federal Highway, Suite 360
Boca Raton, Florida 33431
(561) 998-6700
(561) 998-6707
10-177626 FCO1 CMI
May 16, 23, 2014 14-02214S

NOTICE OF FORECLOSURE SALE IN THE CIRCUIT COURT OF THE TWELFTH JUDICIAL CIRCUIT

IN AND FOR SARASOTA COUNTY, FLORIDA
CASE NO.: 2012 CA 002015 NC
FEDERAL NATIONAL MORTGAGE ASSOCIATION, Plaintiff, vs.
SUSAN L. GADD, UNKNOWN SPOUSE OF SUSAN L. GADD, CITIFINANCIAL EQUITY SERVICES, INC. UNKNOWN TENANT(S) IN POSSESSION #1 and #2, and ALL OTHER UNKNOWN TENANT(S), et al., Defendant(s).

NOTICE IS HEREBY GIVEN pursuant to a Final Summary Judgment of Foreclosure dated May 1, 2014, entered in Civil Case No. 2012 CA 002015 NC of the Circuit Court of the Twelfth Judicial Circuit in and for Sarasota County, Florida, wherein FEDERAL NATIONAL MORTGAGE ASSOCIATION, Plaintiff, and SUSAN L. GADD, CITIFINANCIAL EQUITY SERVICES, INC., UNKNOWN TENANT(S) IN POSSESSION # 1 N/K/A PATRICIA HENSON, UNKNOWN TENANT(S) IN POSSESSION # 2 N/K/A CHARLES HENSON are Defendants.

KAREN E. RUSHING, The Clerk of the Circuit Court, will sell to the highest bidder for cash, www.sarasota.realforeclose.com, at 9:00 AM,

on the 5th day of June, 2014, the following described real property as set forth in said Final Summary Judgment, to wit:

SEE ATTACHED EXHIBIT "A" FOR LEGAL DESCRIPTION Exhibit "A"

All those certain parcels of land situate in the County of Sarasota, State of Florida, being known and designated as follows:

Parcel 1:

Begin at the NE corner of Block J L Unit No. 1, Woodland Homes Subdivision, as recorded in Plat Book 3, Page 9, of the Public Records of Sarasota County, Florida; thence West along the South R/W of Bowers Street (Woodland Boulevard) a distance of 235.30 feet to a P.O.B.; thence continue West along said R/W a distance of 208.72 feet; thence South 0° 10' 00" West a distance of 208.71 feet; thence East a distance of 208.72 feet; thence North 0° 10' 00" East a distance of 208.71 feet to the P.O.B., being and lying in Section 25, Township 36 South, Range 18 East, Sarasota County, Florida, and containing 1.0 acre.

Parcel 2:

Commence at the Southeast

corner of the Northwest ¼ of the Southwest ¼ of Section 25, Township 36 South, Range 18 East; thence S 89° 49' 10" W, a distance of 274.90 feet; thence N 0° 17' 04" E, a distance of 330.67 feet for a point of beginning; thence continue N 0° 17' 04" E, a distance of 107.50 feet to the Southeast corner of the Brewer tract; thence West along South line of Brewer tract, 208.72 feet to the East line of the tract owned by Susan Marilyn Tyler; thence S 00° 17' 04" W, along said Tyler tract, 107.50 feet; thence East, 208.72 feet to the point of beginning. Being and lying in Section 25, Township 36 South, Range 18 East, containing 0.51508878 acre more or less.

If you are a person claiming a right to funds remaining after the sale, you must file a claim with the clerk no later than 60 days after the sale. If you fail to file a claim you will not be entitled to any remaining funds. After 60 days, only the owner of record as of the date of the lis pendens may claim the surplus.

If you cannot afford an attorney, contact Gulfcoast Legal Services at (941)366-1746 or www.gulfcoastlegal.org, or Legal Aid of Manasota at (941)366-0038 or www.legalaidofmanasota.org. If you do not qualify for free legal assistance or do not know

an attorney, you may call an attorney referral service (listed in the phone book), or contact the Florida Bar Lawyer Referral Service at (800)342-8011.

IF YOU ARE A PERSON WITH A DISABILITY WHO NEEDS ANY ACCOMMODATION IN ORDER TO PARTICIPATE IN THIS PROCEEDING, YOU ARE ENTITLED, AT NO COST TO YOU, TO THE PROVISION OF CERTAIN ASSISTANCE. PLEASE CONTACT THE SARASOTA COUNTY JURY OFFICE, P.O. BOX 3079, SARASOTA, FLORIDA 34230-3079, (941)861-7400, AT LEAST SEVEN (7) DAYS BEFORE YOUR SCHEDULED COURT APPEARANCE, OR IMMEDIATELY UPON RECEIVING THIS NOTIFICATION IF THE TIME BEFORE THE SCHEDULED APPEARANCE IS LESS THAN SEVEN (7) DAYS; IF YOU ARE HEARING OR VOICE IMPAIRED, CALL 711.

Dated: 5/12/14

By: Corey M. Ohayon
Florida Bar No.: 0051323.

Attorney for Plaintiff:
Brian L. Rosaler, Esquire
Popkin & Rosaler, P.A.
1701 West Hillsboro Boulevard
Suite 400
Deerfield Beach, FL 33442
Telephone: (954) 360-9030
Facsimile: (954) 420-5187
11-28044
May 16, 23, 2014 14-02167S

SECOND INSERTION

NOTICE OF FORECLOSURE SALE IN THE CIRCUIT COURT OF THE 12TH JUDICIAL CIRCUIT, IN AND FOR SARASOTA COUNTY, FLORIDA

CIVIL DIVISION:
CASE NO.: 2012 CA 003545 NC
FEDERAL NATIONAL MORTGAGE ASSOCIATION, Plaintiff, vs.
WILLIAM T. DAVIES; REGIONS BANK; THE WOODLANDS MASTER ASSOCIATION, INC.; LAURIE C. STROLE; JAMES C. STROLE, JR.; UNKNOWN SPOUSE OF WILLIAM T. DAVIES; UNKNOWN TENANT IN POSSESSION OF THE SUBJECT PROPERTY, Defendants.

NOTICE IS HEREBY GIVEN pursuant to Final Judgment of Foreclosure dated the 5th day of May, 2014, and entered in Case No. 2012 CA 003545 NC, of the Circuit Court of the 12th Judicial Circuit in and for Sarasota County, Florida, wherein FEDERAL NATIONAL MORTGAGE ASSOCIATION is the Plaintiff and WILLIAM T. DAVIES; REGIONS BANK; THE WOODLANDS MASTER ASSOCIATION, INC.; LAURIE C. STROLE; JAMES C. STROLE, JR.; UNKNOWN SPOUSE OF WILLIAM T. DAVIES and UNKNOWN TENANT(S) IN POSSESSION OF THE SUBJECT PROPERTY are defendants. The Clerk of this Court shall sell to the highest and best bidder for cash electronically at www.sarasota.realforeclose.com at 9:00 AM on the 6th day of June, 2014, the following described property as set forth in said Final Judgment, to wit:

LOT 48, BLOCK 82, CEDAR

GROVE PHASE 1A, ACCORDING TO THE PLAT THEREOF, AS RECORDED IN PLAT BOOK 45, PAGE(S) 42, 42A THROUGH 42S, OF THE PUBLIC RECORDS OF SARASOTA COUNTY, FLORIDA.

ANY PERSON CLAIMING AN INTEREST IN THE SURPLUS FROM THE SALE, IF ANY, OTHER THAN THE PROPERTY OWNER AS OF THE DATE OF THE LIS PENDENS MUST FILE A CLAIM WITHIN 60 DAYS AFTER THE SALE.

If you are a person with a disability who needs any accommodation in order to participate in this proceeding, you are entitled, at no cost to you, to the provision of certain assistance. Please contact the Sarasota County Jury Office, P.O. Box 3079, Sarasota, Florida 34230-3079, (941)861-7400, at least seven (7) days before your scheduled court appearance, or immediately upon receiving this notification if the time before the scheduled appearance is less than seven (7) days; if you are hearing or voice impaired, call 711.

Dated this 8 day of May, 2014.
By: Jennifer Nicole Tarquinio
Bar #99192

Choice Legal Group, P.A.
P.O. Box 9908
Fort Lauderdale, FL 33310-0908
Telephone: (954) 453-0365
Facsimile: (954) 771-6052
Toll Free: 1-800-441-2438
DESIGNATED PRIMARY E-MAIL FOR SERVICE PURSUANT TO FLA R. JUD. ADMIN 2.516
eservice@clelegalgroup.com
11-22941
May 16, 23, 2014 14-02096S

SECOND INSERTION

NOTICE OF SALE IN THE CIRCUIT COURT OF THE TWELFTH JUDICIAL CIRCUIT OF THE STATE OF FLORIDA, IN AND FOR SARASOTA COUNTY

CIVIL DIVISION
CASE NO.
58-2012-CA-005329-0000-NC

EVERBANK, Plaintiff, vs.
JAMES R. STARNES; UNKNOWN SPOUSE OF JAMES R. STARNES; IF LIVING, INCLUDING ANY UNKNOWN SPOUSE OF SAID DEFENDANT(S), IF REMARRIED, AND IF DECEASED, THE RESPECTIVE UNKNOWN HEIRS, DEVISEES, GRANTEES, ASSIGNEES, CREDITORS, LIENORS, AND TRUSTEES, AND ALL OTHER PERSONS CLAIMING BY, THROUGH, UNDER OR AGAINST THE NAMED DEFENDANT(S); CITY OF SARASOTA; DEPARTMENT OF HOUSING AND URBAN DEVELOPMENT; WHETHER DISSOLVED OR PRESENTLY EXISTING, TOGETHER WITH ANY GRANTEES, ASSIGNEES, CREDITORS, LIENORS, OR TRUSTEES OF SAID DEFENDANT(S) AND ALL OTHER PERSONS CLAIMING BY, THROUGH, UNDER, OR AGAINST DEFENDANT(S); UNKNOWN TENANT #1; UNKNOWN TENANT #2; Defendant(s)

Notice is hereby given that, pursuant to a Final Summary Judgment of Foreclosure entered on 04/21/2014 in the above styled cause, in the Circuit Court of Sarasota County, Florida, the office of Karen E. Rushing clerk of the circuit

court will sell the property situate in Sarasota County, Florida, described as: Lot 40, Block 681, 17TH ADDITION TO PORT CHARLOTTE, according to the plat thereof, as recorded in Plat Book 13, Page 16, of the Public Records of Sarasota County, Florida.

at public sale, to the highest and best bidder, for cash, www.sarasota.realforeclose.com at 9:00 o'clock, A.M., on May 28, 2014

Any person claiming an interest in the surplus from the sale, if any, other than the property owner as of the date of the lis pendens, must file a claim within 60 days after the sale.

If you are a person with a disability who needs any accommodation in order to participate in this proceeding, you are entitled, at no cost to you, to the provision of certain assistance. Please contact the Sarasota County Jury Office, P.O. Box 3079, Sarasota, Florida 34230-3079, (941)861-7400, at least seven (7) days before your scheduled court appearance, or immediately upon receiving this notification if the time before the scheduled appearance is less than seven (7) days; if you are hearing or voice impaired, call 711.

ATTORNEY FOR PLAINTIFF
By /s/ Josh D. Donnelly
Josh D. Donnelly
Florida Bar #64788
Date: 05/12/2014
THIS INSTRUMENT PREPARED BY:
Law Offices Of Daniel C. Consuegra
9204 King Palm Drive
Tampa, FL 33619-1328
Phone: 813-915-8660
Attorneys for Plaintiff
131892-T
May 16, 23, 2014 14-02143S

SECOND INSERTION

NOTICE OF FORECLOSURE SALE IN THE CIRCUIT COURT OF THE TWELFTH JUDICIAL CIRCUIT IN AND FOR SARASOTA COUNTY, FLORIDA

CIVIL DIVISION
CASE NO.: 58-2012-CA-004402 NC
FEDERAL NATIONAL MORTGAGE ASSOCIATION Plaintiff, v.
JOYCE SOLTIS; ET AL.
Defendants,

NOTICE IS HEREBY GIVEN pursuant to a Final Judgment dated April 28, 2014, entered in Civil Case No.: 58-2012-CA-004402 NC, of the Circuit Court of the TWELFTH Judicial Circuit in and for Sarasota County, Florida, wherein FEDERAL NATIONAL MORTGAGE ASSOCIATION is Plaintiff, and JOYCE SOLTIS; UNKNOWN SPOUSE OF JOYCE SOLTIS; UNKNOWN TENANT #1; UNKNOWN TENANT #2; ALL OTHER UNKNOWN PARTIES CLAIMING INTERESTS BY, THROUGH, UNDER, AND AGAINST A NAMED DEFENDANT(S) WHO ARE NOT KNOWN TO BE DEAD OR ALIVE, WHETHER SAME UNKNOWN PARTIES MAY CLAIM AN INTEREST AS SPOUSES, HEIRS, DEVISEES, GRANTEES, OR OTHER CLAIMANTS, are Defendant(s).

KAREN E. RUSHING, the Clerk of Court shall sell to the highest bidder for cash online at www.Sarasota.Realforeclose.Com at 9:00 a.m. on the 3rd day of June, 2014 the following described real property as set forth in said Final Summary Judgment, to wit:

LOT 43, SPRING LAKE ADDITION NO. 1, AS PER PLAT THEREOF RECORDED IN PLAT BOOK 9, PAGE 40, OF

THE PUBLIC RECORDS OF SARASOTA COUNTY, FLORIDA

If you are a person claiming a right to funds remaining after the sale, you must file a claim with the clerk no later than 60 days after the sale. If you fail to file a claim you will not be entitled to any remaining funds. After 60 days, only the owner of record as of the date of the lis pendens may claim the surplus.

If you are a person with a disability who needs any accommodation in order to participate in this proceeding, you are entitled, at no cost to you, to the provision of certain assistance. Please contact the Sarasota County Jury Office, P.O. Box 3079, Sarasota, Florida 34230-3079, (941)861-7400, at least seven (7) days before your scheduled court appearance, or immediately upon receiving this notification if the time before the scheduled appearance is less than seven (7) days; if you are hearing or voice impaired, call 711.

Dated this 8 day of May, 2014.

/s/ Melody A. Martinez, Esq.
FBN 124151 for
By: Joshua Sabet, Esquire
Fla. Bar No.: 85356
Primary Email:
JSabet@ErwLaw.com
Secondary Email:
docservice@erwlaw.com

Attorney for Plaintiff:
Elizabeth R. Wellborn, P.A.
350 Jim Moran Blvd.
Suite 100 Deerfield
Beach, FL 33442
Telephone: (954) 354-3544
Facsimile: (954) 354-3545
FILE # 7005-02622
May 16, 23, 2014 14-02152S

SECOND INSERTION

RE-NOTICE OF SALE IN THE CIRCUIT COURT OF THE TWELFTH JUDICIAL CIRCUIT, IN AND FOR SARASOTA COUNTY, FLORIDA

CASE NO. 58-2012-CA-000774 NC
US BANK NATIONAL ASSOCIATION, AS TRUSTEE, SUCCESSOR IN INTEREST TO WACHOVIA BANK, NATIONAL ASSOCIATION AS TRUSTEE FOR WELLS FARGO ASSET SECURITIES CORPORATION, MORTGAGE PASS-THROUGH CERTIFICATES, SERIES 2005-AR7; Plaintiff, vs.
SHARON ARATARI, ET AL; Defendants

NOTICE IS HEREBY GIVEN pursuant to an Order rescheduling foreclosure sale dated APRIL 21, 2014 entered in Civil Case No. 58-2012-CA-000774 NC of the Circuit Court of the TWELFTH Judicial Circuit in and for Sarasota County, Florida, wherein US BANK NATIONAL ASSOCIATION, AS TRUSTEE, SUCCESSOR IN INTEREST TO WACHOVIA BANK, NATIONAL ASSOCIATION AS TRUSTEE FOR WELLS FARGO ASSET SECURITIES CORPORATION, MORTGAGE PASS-THROUGH CERTIFICATES, SERIES 2005-AR7, Plaintiff and SHARON ARATARI, ET AL; are defendant(s). The Clerk will sell to the highest and best bidder for cash, AT www.sarasota.realforeclose.com, IN ACCORDANCE WITH CHAPTER 45, FLORIDA STATUTES, AT 9:00 AM, JUNE 03, 2014 the following described property as set forth in said Final Judgment, to-wit:

UNIT 505, BUILDING 2, WOODMERE AT JACARANDA, PHASE 1, A CONDOMINIUM, ACCORDING TO THE DECLARATION THEREOF, AS RECORDED IN OFFICIAL

RECORDS INSTRUMENT # 1998155485, AND AS AMENDED, AND AS PER PLAT THEREOF RECORDED IN CONDOMINIUM BOOK 33, PAGE 3, AND AS AMENDED, OF THE PUBLIC RECORDS OF SARASOTA COUNTY, FLORIDA.

Property Address: 3730 CADBURY CIRCLE, VENICE, FL 34293

ANY PERSON CLAIMING AN INTEREST IN THE SURPLUS FROM THE SALE, IF ANY, OTHER THAN THE PROPERTY OWNER AS OF THE DATE OF THE LIS PENDENS MUST FILE A CLAIM WITHIN 60 DAYS AFTER THE SALE.

If you are a person with a disability who needs any accommodation in order to participate in this proceeding, you are entitled, at no cost to you, to the provision of certain assistance. Please contact the Sarasota County Jury Office, P.O. Box 3079, Sarasota, Florida 34230-3079, (941)861-7400, at least seven (7) days before your scheduled court appearance, or immediately upon receiving this notification if the time before the scheduled appearance is less than seven (7) days; if you are hearing or voice impaired, call 711.

DATED at Sarasota, Florida, this 09 day of May, 2014.

By: Jessica M. Aldeguer, Esq.
FBN. 100678

Attorneys for Plaintiff
Marinosi Law Group, P.C.
100 West Cypress Creek Road,
Suite 1045
Fort Lauderdale, FL 33309
Phone: (954)-644-8704;
Fax (954) 772-9601
ServiceFL@mlg-defaultlaw.com
ServiceFL2@mlg-defaultlaw.com
11-04672
May 16, 23, 2014 14-02130S

SECOND INSERTION

NOTICE OF FORECLOSURE SALE IN THE CIRCUIT COURT OF THE TWELFTH JUDICIAL CIRCUIT IN AND FOR SARASOTA COUNTY, FLORIDA

CIVIL DIVISION
CASE NO.: 2010-CA-009602 NC
BANK OF AMERICA, N.A.

Plaintiff, v.
MYKOLA BAZYLUK; ET AL.
Defendants,

NOTICE IS HEREBY GIVEN pursuant to a Final Judgment dated April 11, 2014, entered in Civil Case No.: 2010-CA-009602 NC, of the Circuit Court of the TWELFTH Judicial Circuit in and for Sarasota County, Florida, wherein GREEN TREE SERVICE-ING, LLC is Plaintiff, and MYKOLA BAZYLUK; ANTONINA BAZYLUK; ANTONINA BAZYLUK REVOCABLE TRUST DATED FEBRUARY 14, 2007; UNKNOWN TRUSTEES OF THE ANTONINA BAZYLUK REVOCABLE TRUST DATED FEBRUARY 14, 2007; UNKNOWN BENEFICIARIES OF THE ANTONINA BAZYLUK REVOCABLE TRUST DATED FEBRUARY 14; UNKNOWN TENANT #1; UNKNOWN TENANT #2; ALL OTHER UNKNOWN PARTIES CLAIMING INTERESTS BY, THROUGH, UNDER, AND AGAINST A NAMED DEFENDANT(S) WHO ARE NOT KNOWN TO BE DEAD OR ALIVE, WHETHER SAME UNKNOWN PARTIES MAY CLAIM AN INTEREST AS SPOUSES, HEIRS, DEVISEES, GRANTEES, OR OTHER CLAIMANTS, are Defendant(s).

KAREN E. RUSHING, the Clerk of Court shall sell to the highest bidder for cash online at www.Sarasota.Realforeclose.Com at 9:00 a.m. on the 30th day of May, 2014 the following described real property as set forth in said Final Summary Judgment, to wit:

LOT 27, RIVENDELL, UNIT 3 C THE WOODLANDS, ACCORDING TO THE PLAT THEREOF, RECORDED IN PLAT BOOK 40, PAGE 40, OF THE PUBLIC RECORDS OF SARASOTA COUNTY, FLORIDA.

If you are a person claiming a right to funds remaining after the sale, you must file a claim with the clerk no later than 60 days after the sale. If you fail to file a claim you will not be entitled to any remaining funds. After 60 days, only the owner of record as of the date of the lis pendens may claim the surplus.

If you are a person with a disability who needs any accommodation in order to participate in this proceeding, you are entitled, at no cost to you, to the provision of certain assistance. Please contact the Sarasota County Jury Office, P.O. Box 3079, Sarasota, Florida 34230-3079, (941)861-7400, at least seven (7) days before your scheduled court appearance, or immediately upon receiving this notification if the time before the scheduled appearance is less than seven (7) days; if you are hearing or voice impaired, call 711.

Dated this 2 day of May, 2014.
/s/ Joshua Sabet
By: Joshua Sabet, Esquire
Fla. Bar No.: 85356
Primary Email:
JSabet@ErwLaw.com
Secondary Email:
docservice@erwlaw.com
Attorney for Plaintiff:
Elizabeth R. Wellborn, P.A.
350 Jim Moran Blvd. Suite 100
Deerfield Beach, FL 33442
Telephone: (954) 354-3544
Facsimile: (954) 354-3545
FILE # 8377ST-25187
May 16, 23, 2014 14-02133S

SECOND INSERTION

NOTICE OF SALE IN THE CIRCUIT COURT OF THE TWELFTH JUDICIAL CIRCUIT IN AND FOR SARASOTA COUNTY, FLORIDA

CIVIL DIVISION
CASE #: 2010-CA-009067 NC
DIVISION: A

BAC Home Loans Servicing, L.P. f/k/a Countrywide Home Loans Servicing, L.P.

Plaintiff, vs.-
SRQUS, LLC; Patrick M. Davis; Wells Fargo Bank, N.A., as Successor by Merger with Wachovia Bank, National Association; Parkridge Condominium Association, Inc.; Unknown Tenants in Possession #1; If living, and all Unknown Parties claiming by, through, under and against the above named Defendant(s) who are not known to be dead or alive, whether said Unknown Parties may claim an interest as Spouse, Heirs, Devisees, Grantees, or Other Claimants

Defendant(s).

NOTICE IS HEREBY GIVEN pursuant to order rescheduling foreclosure sale or Final Judgment, entered in Civil Case No. 2010-CA-009067 NC of the Circuit Court of the 12th Judicial Circuit in and for Sarasota County, Florida, wherein BAC Home Loans Servicing, L.P. f/k/a Countrywide Home Loans Servicing, L.P., Plaintiff and SRQUS, LLC are defendant(s), I, Clerk of Court, Karen E. Rushing, will sell to the highest and best bidder for cash VIA THE INTERNET AT WWW.SARASOTA.REALFORECLOSE.COM, AT 9:00 A.M. on June 23, 2014, the following described property as set forth in said Final Judgment, to-wit:

CONDOMINIUM UNIT

NO. 34-203, PHASE 34, PARKRIDGE CONDOMINIUM, ACCORDING TO THE DECLARATION OF CONDOMINIUM THEREOF, AS RECORDED IN INSTRUMENT NO. 2004046838, AS AMENDED FROM TIME TO TIME, OF THE PUBLIC RECORDS OF SARASOTA COUNTY, FLORIDA. TOGETHER WITH AN UNDIVIDED INTEREST IN THE COMMON ELEMENTS APPURTENANT THERETO.

ANY PERSON CLAIMING AN INTEREST IN THE SURPLUS FROM THE SALE, IF ANY, OTHER THAN THE PROPERTY OWNER AS OF THE DATE OF THE LIS PENDENS MUST FILE A CLAIM WITHIN 60 DAYS AFTER THE SALE.

If you are a person with a disability who needs any accommodation in order to participate in this proceeding, you are entitled, at no cost to you, to the provision of certain assistance. Please contact the Sarasota County Jury Office, P.O. Box 3079, Sarasota, Florida 34230-3079, (941)861-7400, at least seven (7) days before your scheduled court appearance, or immediately upon receiving this notification if the time before the scheduled appearance is less than seven (7) days; if you are hearing or voice impaired, call 711.

Submitted By:
ATTORNEY FOR PLAINTIFF:
SHAPIRO, FISHMAN
& GACHÉ, LLP
2424 North Federal Highway,
Suite 360
Boca Raton, Florida 33431
(561) 998-6700
(561) 998-6707
10-182567 FCO1 CWF
May 16, 23, 2014 14-02132S

SECOND INSERTION

NOTICE OF SALE IN THE CIRCUIT COURT OF THE TWELFTH JUDICIAL CIRCUIT IN AND FOR SARASOTA COUNTY, FLORIDA
Case No.: 58-2009-CA-014181 NC
Section: C
CITIMORTGAGE, INC. Plaintiff, v. KIRK SHIER; MARGARET SHIER; ANY AND ALL UNKNOWN PARTIES CLAIMING BY, THROUGH, UNDER, AND AGAINST THE HEREIN NAMED INDIVIDUAL DEFENDANT(S) WHO ARE NOT KNOWN TO BE DEAD OR ALIVE, WHETHER SAID UNKNOWN PARTIES MAY CLAIM AN INTEREST AS SPOUSES, HEIRS, DEVISEES, GRANTEES, OR OTHER CLAIMANTS; SUNCOAST SCHOOLS FEDERAL CREDIT UNION. Defendant(s).
 NOTICE IS HEREBY GIVEN pursuant to an Order on Plaintiff's Amended Motion to Reset Foreclosure Sale and Withdrawal of Motion to Amend Final Judgment dated April 11, 2014, entered in Civil Case No. 58-2009-CA-014181 NC of the Circuit Court of the Twelfth Judicial Circuit in and for Sarasota County, Florida, wherein the Clerk of the Circuit Court will sell to the highest bidder for cash on the 28th day of May, 2014, at 9:00 a.m. online at the website: <https://www.sarasota.realforeclose.com>, relative to the following described property as set forth in the Final Judgment, to wit:
 LOT 17, BLOCK 188 2ND ADDITION TO PORT CHARLOTTE AS PER PLAT THEROF RECORDED IN PLAT BOOK 11, PAGES 30, 30A THROUGH 30G, OF THE PUBLIC RECORDS OF SARASOTA COUNTY, FLORIDA.
 Any person claiming an interest in the surplus from the sale, if any, other than the property owner as of the date of the Lis Pendens must file a claim within 60 days after the sale.
 If you are a person with a disability who needs any accommodation in order to participate in this proceeding, you are entitled, at no cost to you, to the provision of certain assistance. Please contact the Sarasota County Jury Office, P.O. Box 3079, Sarasota, Florida 34230-3079, (941)861-7400, at least seven (7) days before your scheduled court appearance, or immediately upon receiving this notification if the time before the scheduled appearance is less than seven (7) days; if you are hearing or voice impaired, call 711.
MORRIS|HARDWICK|SCHNEIDER, LLC
 By: Jennifer L. Heath, Esq., FBN: 103906
 9409 Philadelphia Road
 Baltimore, Maryland 21237
 Mailing Address:
 Morris|Hardwick|Schneider, LLC
 5110 Eisenhower Blvd., Suite 302A
 Tampa, Florida 33634
 Customer Service (866)-503-4930
 MHSinbox@closingsource.net
 FL-97001563-09
 10676328
 May 16, 23, 2014 14-02164S

SECOND INSERTION

NOTICE OF FORECLOSURE SALE IN THE CIRCUIT COURT OF THE TWELFTH JUDICIAL CIRCUIT IN AND FOR SARASOTA COUNTY, FLORIDA
Case No.: 2012 CA 005750 NC
HSBC BANK USA, NATIONAL ASSOCIATION, AS TRUSTEE FOR THE CERTIFICATEHOLDERS OF ACE SECURITIES CORP. HOME EQUITY LOAN TRUST, SERIES 2006-NC3 ASSET-BACKED PASS-THROUGH CERTIFICATES, Plaintiff, vs. KENNETH C. CAMPBELL A/K/A KENNETH CAMPBELL, PAMELA THOMAS CAMPBELL UNKNOWN TENANT(S) IN POSSESSION #1 and #2, and ALL OTHER UNKNOWN PARTIES, et.al., Defendant(s).
 NOTICE IS HEREBY GIVEN pursuant to a Final Summary Judgment of Foreclosure dated March 10, 2014, entered in Civil Case No.: 2012 CA 005750 NC of the Circuit Court of the Twelfth Judicial Circuit in and for Sarasota County, Florida, wherein HSBC BANK USA, NATIONAL ASSOCIATION, AS TRUSTEE FOR THE CERTIFICATEHOLDERS OF ACE SECURITIES CORP. HOME EQUITY LOAN TRUST, SERIES 2006-NC3 ASSET-BACKED PASS-THROUGH CERTIFICATES, Plaintiff, and KENNETH C. CAMPBELL A/K/A KENNETH CAMPBELL, PAMELA THOMAS CAMPBELL, are Defendants.
 KAREN E. RUSHING, The Clerk of the Circuit Court, will sell to the highest bidder for cash, www.sarasota.realforeclose.com, at 09:00 AM, on the 9th day of June, 2014, the following described real property as set forth in said Final Summary Judgment, to wit:
 LOT 15, BLOCK 1660, 33RD ADDITION TO PORT CHARLOTTE SUBDIVISION, ACCORDING TO THE MAP OR PLAT THEREOF, AS RECORDED IN PLAT BOOK 15, PAGES 17A THROUGH 17N, OF THE

SECOND INSERTION

RE-NOTICE OF FORECLOSURE SALE IN THE CIRCUIT COURT OF THE TWELFTH JUDICIAL CIRCUIT, IN AND FOR SARASOTA COUNTY, FLORIDA
CIVIL DIVISION
Case No.: 2009 CA 005616 NC
J.P. MORGAN ALTERNATIVE LOAN TRUST 2006-S4, MORTGAGE PASS-THROUGH CERTIFICATES, U.S. BANK NATIONAL ASSOCIATION, AS TRUSTEE Plaintiff, vs. GARY R. PETERSEN, et al Defendants.
 RE-NOTICE IS HEREBY GIVEN pursuant to an Order Granting Plaintiff's Motion to Reschedule Foreclosure Sale filed May 6, 2014 and entered in Case No. 2009 CA 005616 NC of the Circuit Court of the Twelfth Judicial Circuit in and for SARASOTA COUNTY, Florida, wherein J.P. MORGAN ALTERNATIVE LOAN TRUST 2006-S4, MORTGAGE PASS-THROUGH CERTIFICATES, U.S. BANK NATIONAL ASSOCIATION, AS TRUSTEE, is Plaintiff, and GARY R. PETERSEN, et al are Defendants, the clerk will sell to the highest and best bidder for cash, beginning at 09:00 AM at www.sarasota.realforeclose.com, in accordance with Chapter 45, Florida Statutes, on the 03 day of July, 2014, the following described property as set forth in said Lis Pendens, to wit:
 LOT 145, SADDLE CREEK, UNIT NO.3, AS PER PLAT THEREOF RECORDED IN PLAT BOOK 28,PAGES 30, 30A THROUGH 30D, INCLUSIVE, OF THE PUBLIC RECORDS OF SARASOTA COUNTY, FLORIDA.
 Any person claiming an interest in the surplus funds from the sale, if any, other than the property owner as of the date of the lis pendens must file a claim within 60 days after the sale.
 If you are a person with a disability who needs any accommodation in order to participate in this proceeding, you are entitled, at no cost to you, to the provision of certain assistance. Please contact the Sarasota County Jury Office, P.O. Box 3079, Sarasota, Florida 34230-3079, (941)861-7400, at least seven (7) days before your scheduled court appearance, or immediately upon receiving this notification if the time before the scheduled appearance is less than seven (7) days; if you are hearing or voice impaired, call 711.
 Dated: May 12, 2014
 By: /s/ Heather Griffiths
 Phelan Hallinan, PLLC
 Heather Griffiths, Esq., Florida Bar No. 0091444
 Emilio R. Lenzi, Esq., Florida Bar No. 0668273
 Phelan Hallinan, PLLC
 Attorneys for Plaintiff
 2727 West Cypress Creek Road
 Ft. Lauderdale, FL 33309
 Tel: 954-462-7000
 Fax: 954-462-7001
 Service by email:
 FL.Service@PhelanHallinan.com
 May 16, 23, 2014 14-02165S

PUBLIC RECORDS OF SARASOTA COUNTY, FLORIDA.
 If you are a person claiming a right to funds remaining after the sale, you must file a claim with the clerk no later than 60 days after the sale. If you fail to file a claim you will not be entitled to any remaining funds. After 60 days, only the owner of record as of the date of the lis pendens may claim the surplus.
 If you cannot afford an attorney, contact Gulfcoast Legal Services at (941)366-1746 or www.gulfcoastlegal.org, or Legal Aid of Manasota at (941)366-0038 or www.legalaid-ofmanasota.org. If you do not qualify for free legal assistance or do not know an attorney, you may call an attorney referral service (listed in the phone book), or contact the Florida Bar Lawyer Referral Service at (800)342-8011.
 IF YOU ARE A PERSON WITH A DISABILITY WHO NEEDS ANY ACCOMMODATION IN ORDER TO PARTICIPATE IN THIS PROCEEDING, YOU ARE ENTITLED, AT NO COST TO YOU, TO THE PROVISION OF CERTAIN ASSISTANCE. PLEASE CONTACT THE SARASOTA COUNTY JURY OFFICE, P.O. BOX 3079, SARASOTA, FLORIDA 34230-3079, (941)861-7400, AT LEAST SEVEN (7) DAYS BEFORE YOUR SCHEDULED COURT APPEARANCE, OR IMMEDIATELY UPON RECEIVING THIS NOTIFICATION IF THE TIME BEFORE THE SCHEDULED APPEARANCE IS LESS THAN SEVEN (7) DAYS; IF YOU ARE HEARING OR VOICE IMPAIRED, CALL 711.
 Dated: 5/12/14
 By: Corey M. Ohayon
 Florida Bar No.: 0051323.
 Attorney for Plaintiff:
 Brian L. Rosaler, Esquire
 Popkin & Rosaler, P.A.
 1701 West Hillsboro Boulevard
 Suite 400
 Deerfield Beach, FL 33442
 Telephone: (954) 360-9030
 Facsimile: (954) 420-5187
 11-31390
 May 16, 23, 2014 14-02169S

SECOND INSERTION

NOTICE OF SALE IN THE CIRCUIT COURT OF THE TWELFTH JUDICIAL CIRCUIT OF THE STATE OF FLORIDA, IN AND FOR SARASOTA COUNTY
CIVIL DIVISION
Case No. 58-2013-CA-000506-0000-NC
JPMORGAN CHASE BANK, NATIONAL ASSOCIATION, Plaintiff, vs. MAYELA MITCHELL MCLEOD F/K/A MAYELLA P. MITCHELL A/K/A MAYELLA PEARLINE MITCHELL; UNKNOWN SPOUSE OF MAYELA MITCHELL MCLEOD F/K/A MAYELLA P. MITCHELL A/K/A MAYELLA PEARLINE MITCHELL; IF LIVING, INCLUDING ANY UNKNOWN SPOUSE OF SAID DEFENDANT(S), IF REMARRIED, AND IF DECEASED, THE RESPECTIVE UNKNOWN HEIRS, DEVISEES, GRANTEES, ASSIGNEES, CREDITORS, LIENORS, AND TRUSTEES, AND ALL OTHER PERSONS CLAIMING BY, THROUGH, UNDER OR AGAINST THE NAMED DEFENDANT(S); UNKNOWN TENANT # 1; UNKNOWN TENANT # 2; Defendant(s)
 Notice is hereby given that, pursuant to a Final Summary Judgment of Foreclosure entered on 04/21/2014 in the above styled cause, in the Circuit Court of Sarasota County, Florida, the office of Karen E. Rushing clerk of the circuit court will sell the property situate in Sarasota County, Florida, described as:

SECOND INSERTION

RE-NOTICE OF FORECLOSURE SALE IN THE CIRCUIT COURT OF THE FOURTEENTH JUDICIAL CIRCUIT, IN AND FOR SARASOTA COUNTY, FLORIDA
Case No. 2007 CA 015230 NC
Division: C
Deutsche Bank National Trust Company, As Trustee Under The Pooling And Servicing Agreement Dated As Of April 1, 2003, Morgan Stanley Capital I Inc. Trust 2003-NC4 Plaintiff Vs. DARLENE BALKE; DARLENE BALKE; DEBORAH E FOCHT; , ET AL Defendants
 NOTICE IS HEREBY GIVEN that, pursuant to an order rescheduling the Foreclosure sale dated April 24, 2014, and entered in Case No. 2007 CA 015230 NC, of the Circuit Court of the Twelfth Judicial Circuit in and for Sarasota County, Florida. Deutsche Bank National Trust Company, As Trustee Under The Pooling And Servicing Agreement Dated As Of April 1, 2003, Morgan Stanley Capital I Inc. Trust 2003-NC4, Plaintiff and DARLENE BALKE; DARLENE BALKE; DEBORAH E FOCHT; , ET AL, are defendants. The Clerk of the Court will sell to the highest and best bidder for cash, at www.sarasota.realforeclose.com SALE BEGINNING AT 09:00 AM on this June 23rd, 2014, the following described property as set forth in the Final Judgment, dated August 30, 2010.
 LOT 19, BLOCK B, BAHIA VISTA HIGHLANDS, AS PER

SECOND INSERTION

NOTICE OF SALE IN THE CIRCUIT COURT OF THE TWELFTH JUDICIAL CIRCUIT OF THE STATE OF FLORIDA, IN AND FOR SARASOTA COUNTY
CIVIL DIVISION
Case No. 58-2012-CA-007909-0000-NC
JPMORGAN CHASE BANK, NATIONAL ASSOCIATION, Plaintiff, vs. UNKNOWN HEIRS, DEVISEES, GRANTEES, ASSIGNEES, CREDITORS, LIENORS, TRUSTEES CYNTHIA LYNN TODD, DECEASED; BETTY TODD, HEIR; CYNTHIA LYNN TODD; UNKNOWN SPOUSE OF CYNTHIA LYNN TODD; IF LIVING, INCLUDING ANY UNKNOWN SPOUSE OF SAID DEFENDANT(S), IF REMARRIED, AND IF DECEASED, THE RESPECTIVE UNKNOWN HEIRS, DEVISEES, GRANTEES, ASSIGNEES, CREDITORS, LIENORS, AND TRUSTEES, AND ALL OTHER PERSONS CLAIMING BY, THROUGH, UNDER, OR AGAINST THE NAMED DEFENDANT(S); SOUTH GATE COMMUNITY ASSOCIATION, INC.; WHETHER DISSOLVED OR PRESENTLY EXISTING, TOGETHER WITH ANY GRANTEES, ASSIGNEES, CREDITORS, LIENORS, OR TRUSTEES OF SAID DEFENDANT(S) AND ALL OTHER PERSONS CLAIMING BY, THROUGH, UNDER, OR AGAINST DEFENDANT(S); UNKNOWN TENANT #1; UNKNOWN TENANT #2; Defendant(s)
 Notice is hereby given that, pursuant to a Final Summary Judgment of Foreclosure entered on 04/21/2014 in the

Lot 12, Block 2517, 50TH ADDITION TQ PORT CHARLOTTE SUBDIVISION, according to the plat thereof, as recorded in Plat Book 21, Page 7, of the Public Records of Sarasota County, Florida.
 at public sale, to the highest and best bidder, for cash, www.sarasota.realforeclose.com at 9:00 o'clock, A.M., on May 29, 2014
 Any person claiming an interest in the surplus from the sale, if any, other than the property owner as of the date of the lis pendens, must file a claim within 60 days after the sale.
 If you are a person with a disability who needs any accommodation in order to participate in this proceeding, you are entitled, at no cost to you, to the provision of certain assistance. Please contact the Sarasota County Jury Office, P.O. Box 3079, Sarasota, Florida 34230-3079, (941)861-7400, at least seven (7) days before your scheduled court appearance, or immediately upon receiving this notification if the time before the scheduled appearance is less than seven (7) days; if you are hearing or voice impaired, call 711.
ATTORNEY FOR PLAINTIFF
 By /S/ Josh D. Donnelly
 Josh D. Donnelly
 Florida Bar #64788
 Date: 05/13/2014
 THIS INSTRUMENT PREPARED BY:
 Law Offices Of Daniel C. Consuegra
 9204 King Palm Drive
 Tampa, FL 33619-1328
 Phone: 813-915-8660
 Attorneys for Plaintiff
 131566-T
 May 16, 23, 2014 14-02220S

SECOND INSERTION

PLAT THEREOF RECORDED IN PLAT BOOK 1, PAGES 128 AND 129, OF THE PUBLIC RECORDS OF SARASOTA COUNTY, FL.
 Property Address: 1021 South Allendale Avenue, Sarasota, FL 34237
 A person claiming an interest in the surplus from the sale, if any, other than the property owner as of the date of the lis pendens must file a claim within 60 days after the sale.
 This notice is provided pursuant to Administrative Order No.2.065.
 If you are a person with a disability who needs any accommodation in order to participate in this proceeding, you are entitled, at no cost to you, to the provision of certain assistance. Please contact the Sarasota County Jury Office, P.O. Box 3079, Sarasota, Florida 34230-3079, (941)861-7400, at least seven (7) days before your scheduled court appearance, or immediately upon receiving this notification if the time before the scheduled appearance is less than seven (7) days; if you are hearing or voice impaired, call 711.
 Dated this 12 day of May, 2014.
 By: Alemayehu Kassahun, Esquire
 F. Bar #44322
 FLEService@udren.com
 UDREN LAW OFFICES, P.C.
 2101 W. Commercial Blvd., Suite 5000
 Fort Lauderdale, FL 33309
 Telephone 954-378-1757
 Fax 954-378-1758
 MJU #11030755-1
 May 16, 23, 2014 14-02170S

SECOND INSERTION

above styled cause, in the Circuit Court of Sarasota County, Florida, the office of Karen E. Rushing clerk of the circuit court will sell the property situate in Sarasota County, Florida, described as: LOT 4, BLOCK 30, SOUTH GATE, UNIT NO. 9, ACCORDING TO THE PLAT THEREOF RECORDED IN PLAT BOOK 8, PAGE 81, OF THE PUBLIC RECORDS OF SARASOTA COUNTY, FLORIDA.
 at public sale, to the highest and best bidder, for cash, www.sarasota.realforeclose.com at 9:00 o'clock, A.M., on May 28, 2014
 Any person claiming an interest in the surplus from the sale, if any, other than the property owner as of the date of the lis pendens, must file a claim within 60 days after the sale.
 If you are a person with a disability who needs any accommodation in order to participate in this proceeding, you are entitled, at no cost to you, to the provision of certain assistance. Please contact the Sarasota County Jury Office, P.O. Box 3079, Sarasota, Florida 34230-3079, (941)861-7400, at least seven (7) days before your scheduled court appearance, or immediately upon receiving this notification if the time before the scheduled appearance is less than seven (7) days; if you are hearing or voice impaired, call 711.
ATTORNEY FOR PLAINTIFF
 By /S/ Josh D. Donnelly
 Josh D. Donnelly
 Florida Bar #64788
 Date: 05/13/2014
 THIS INSTRUMENT PREPARED BY:
 Law Offices Of Daniel C. Consuegra
 9204 King Palm Drive
 Tampa, FL 33619-1328
 Phone: 813-915-8660
 Attorneys for Plaintiff
 103435-T2
 May 16, 23, 2014 14-02201S

SECOND INSERTION

NOTICE OF FORECLOSURE SALE IN THE CIRCUIT COURT OF THE TWELFTH JUDICIAL CIRCUIT IN AND FOR SARASOTA COUNTY, FLORIDA
GENERAL JURISDICTION DIVISION
Case No. 2008-CA-015437-NC
U.S. BANK NATIONAL ASSOCIATION, AS TRUSTEE FOR BEAR STEARNS ASSET BACKED SECURITIES I TRUST 2006-AC3, ASSET-BACKED CERTIFICATES, SERIES 2006-AC3, Plaintiff, vs. PATRICIA D. REED A/K/A PATRICIA REED; DENNIS R. PINE; et. al. Defendant(s).
 NOTICE IS HEREBY GIVEN pursuant to a Final Judgment of Foreclosure dated April 15, 2011, and entered in 2008-CA-015437-NC of the Circuit Court of the TWELFTH Judicial Circuit in and for Sarasota County, Florida, wherein AMERICAN HOME MORTGAGE SERVICING, INC., is the Plaintiff and PATRICIA D. REED A/K/A PATRICIA REED; DENNIS R. PINE; UNKNOWN PARTIES IN POSSESSION #1; UNKNOWN PARTIES IN POSSESSION #2 are the Defendant(s). Karen Rushing as the Clerk of the Circuit Court will sell to the highest and best bidder for cash at www.sarasota.realforeclose.com, at 09:00 AM, on May 28, 2014, the following described property as set forth in said Final Judgment, to wit:
 LOT 121, DESOTO LAKES, UNIT 4, ACCORDING TO THE PLAT THEREOF, IN PLAT BOOK 8, PAGE 118, PUBLIC RECORDS OF SARASOTA COUNTY, FLORIDA.
 Any person claiming an interest in the surplus from the sale, if any, other than the property owner as of the date of the lis pendens must file a claim within 60 days after the sale.
 If you are a person with a disability who needs any accommodation in order to participate in this proceeding, you are entitled, at no cost to you, to the provision of certain assistance. Please contact the Sarasota County Jury Office, P.O. Box 3079, Sarasota, Florida 34230-3079, (941)861-7400, at least seven (7) days before your scheduled court appearance, or immediately upon receiving this notification if the time before the scheduled appearance is less than seven (7) days; if you are hearing or voice impaired, call 711.
 Dated this 6 day of May, 2014.
 By: Philip Jones
 Philip Jones
 Florida Bar # 107721
 Robertson, Anschutz & Schneid, PL
 Attorneys for Plaintiff
 6409 Congress Avenue, Suite 100
 Boca Raton, Florida 33487
 13-16119
 May 16, 23, 2014 14-02109S

SECOND INSERTION

NOTICE OF SALE IN THE TWELFTH JUDICIAL CIRCUIT COURT IN AND FOR SARASOTA COUNTY, FLORIDA
CIVIL ACTION
Case #: 2014 CA 001128 NC
CITY OF SARASOTA, FLORIDA, a municipal corporation, Plaintiff, v. DORIS JEAN WOODS; CITIFINANCIAL EQUITY SERVICES, INC; AND SARASOTA COUNTY, Defendant
 Notice is hereby given pursuant to the Final Summary Judgment of Foreclosure entered in the above noted case, that the Clerk of Court will sell the following property situated in Sarasota County, Florida, described as:
 A parcel of land lying in parts of Lots 11 & 13, LILLY'S SUBDIVISION, more particularly described as follows:
 Commence at the NE corner of Lot 11 of Lilly's subdivision as recorded in Deed Book 250, Page 84, Public Records of Sarasota County, Florida, said corner being on the Westerly R/W of a 30' road; thence S 6 deg. 30'00"E, 90.39'; thence S 89 deg. 57'00"W, 89.60' for a P.O.B.; thence S 4 deg. 48'00"E, 120.10'; thence S 89 deg. 54'00"W, 93.95'; thence N 2 deg. 23'38"W, 119.80'; thence 89 deg. 57'00" E, 89.60 ft. to the P.O.B., lying and being in Section 31, Township 39 South, Range 19 East, Sarasota County, Florida, SUBJECT TO A 30-foot ingress and egress easement along the N'y boundary of the above-described property. Less and except that portion deeded to Sarasota County for road right-of-way in Official Records Book 2872, Page 178 of the Public Records of Sarasota County, Florida.
 This is Parcel ID No. 0383130021 located at 615 Jones Street, Laurel, Florida 34275.

SECOND INSERTION

NOTICE OF ACTION-CONSTRUCTIVE SERVICE IN THE CIRCUIT COURT OF THE TWELFTH JUDICIAL CIRCUIT IN AND FOR SARASOTA COUNTY, FLORIDA
GENERAL JURISDICTION DIVISION
Case No. 2014 CA 001269 NC
Bank of America, N.A. Plaintiff, vs. Stephen Cramer; Unknown Spouse of Stephen Cramer; Lynne McLain f/k/a Lynne M. Cramer a/k/a Lynne Cramer; Bank of America, N.A. Defendants.
 TO: Lynne McLain f/k/a Lynne M. Cramer a/k/a Lynne Cramer
 Last Known Address: 72 Limekiln Road, Columbia, NJ 07832
 YOU ARE HEREBY NOTIFIED that an action to foreclose a mortgage on the following property in Sarasota County, Florida:
 LOT 28, BLOCK 3682, PORT CHARLOTTE SUBDIVISION, SECTION 65, ACCORDING TO THE PLAT THEREOF, AS RECORDED IN PLAT BOOK 6, PAGES 3A THROUGH 3P, INCLUSIVE, OF THE PUBLIC RECORDS OF CHARLOTTE COUNTY, FLORIDA.
 has been filed against you and you are required to serve a copy of your written defenses, if any, to it on Kathleen Pierrilus, Esquire, Brock & Scott, PLLC, the Plaintiff's attorney, whose address is 1501 N.W. 49th Street, Suite 200, Ft. Lauderdale, FL 33309, on or before June 16th, 2014, and file the original with the Clerk of this Court either before service on the Plaintiff's attorney or immediately thereafter; otherwise a default will be entered against you for the relief demanded in the complaint or petition.
 If you are a person with a disability who needs any accommodation in order to participate in this proceeding, you are entitled, at no cost to you, to the provision of certain assistance. Please contact the Sarasota County Jury Office, P.O. Box 3079, Sarasota, Florida 34230-3079, (941)861-7400, at least seven (7) days before your scheduled court appearance, or immediately upon receiving this notification if the time before the scheduled appearance is less than seven (7) days; if you are hearing or voice impaired, call 711.
 DATED on May 9th, 2014.
 Karen Rushing
 As Clerk of the Court
 (SEAL) By L. Szymanski
 As Deputy Clerk
 Kathleen Pierrilus, Esquire
 Brock & Scott, PLLC
 the Plaintiff's Attorney
 1501 N.W. 49th St., Suite 200
 Ft. Lauderdale, FL 33309
 File # 13-F05945
 May 16, 23, 2014 14-02139S

SECOND INSERTION

at public sale, to the highest and best bidder for cash, with the foreclosure sale to be conducted via the internet, www.sarasota.realforeclose.com, at 9:00 a.m. on June 6, 2014. The highest bidder shall immediately post with the Clerk, a deposit equal to 5% of the final bid. The deposit must be cash or cashier's check payable to the Clerk of the Circuit Court. Final payment must be made on or before 5:00 p.m. of the date of the sale by cash or cashier's check.
 IF YOU ARE A PERSON CLAIMING A RIGHT TO FUNDS REMAINING AFTER THE SALE, YOU MUST FILE A CLAIM WITH THE CLERK NO LATER THAN 60 DAYS AFTER THE SALE. IF YOU FAIL TO FILE A CLAIM, YOU WILL NOT BE ENTITLED TO ANY REMAINING FUNDS. AFTER 60 DAYS, ONLY THE OWNER OF RECORD AS OF THE DATE OF THE LIS PENDENS MAY CLAIM THE SURPLUS.
 If you are a person with a disability who needs any accommodation in order to participate in this proceeding, you are entitled, at no cost to you, to the provision of certain assistance. Please contact the Sarasota County Jury Office, P.O. Box 3079, Sarasota, Florida 34230-3079, (941)861-7400, at least seven (7) days before your scheduled court appearance, or immediately upon receiving this notification if the time before the scheduled appearance is less than seven (7) days; if you are hearing or voice impaired, call 711.
 AS OFFICER OF THE COURT
 By: Michael A. Connolly
 Florida Bar No. 341959
 FOURNIER, CONNOLLY, WARREN & SHAMSEY, P.A.
 1 South School Avenue, Suite 700
 Sarasota, Florida 34237
 Telephone: (941) 906-1199
 Facsimile: (941) 906-1890
 E-mail:
 mike.connolly@sarasotagov.com
 ATTORNEYS FOR CITY OF SARASOTA
 May 16, 23, 2014 14-02098S

SECOND INSERTION

NOTICE OF APPLICATION FOR TAX DEED

Notice is hereby given that LAWRENCE LEVICK FAM TRUST, the holder of the certificate listed below, has filed said certificate for a tax deed to be issued. The certificate number and year of issuance, the description of the property, and the names in which the property is assessed are as follows:

Certificate Number: 8520.000
Year of Issuance: 2012
Tax Deed File #: 14-0104 TD

Description of Property: 1124101639 LOTS 39 & 40 BLK 1016 21ST ADD TO PORT CHARLOTTE
Name in which the property is assessed: INA GROUP LLC
All of said property being in the County of Sarasota, State of Florida. Unless the certificate is redeemed according to law, the property described in the certificate will be sold to the highest bidder at the Sarasota County Court House, 2000 Main Street, Historic Courtroom, East Wing, Sarasota, Florida, at 9:00 a.m. on the 17TH day of JUNE, 2014.

Karen E. Rushing
Clerk Of The Circuit Court
Sarasota County, Florida
By: T. Lake, Deputy Clerk
Publication Dates: MAY 16, 23, 30;
JUNE 6, 2014

14-02198S

SECOND INSERTION

NOTICE OF APPLICATION FOR TAX DEED

Notice is hereby given that LAWRENCE LEVICK FAM TRUST, the holder of the certificate listed below, has filed said certificate for a tax deed to be issued. The certificate number and year of issuance, the description of the property, and the names in which the property is assessed are as follows:

Certificate Number: 3916.000
Year of Issuance: 2012
Tax Deed File #: 14-0105 TD

Description of Property: 0768150044 LOTS 6 & 7 BLK B WARM MINERAL SPRINGS UNIT 63
Name in which the property is assessed: BOGUSLAWA HNATIW & WASYL HNATIW
All of said property being in the County of Sarasota, State of Florida. Unless the certificate is redeemed according to law, the property described in the certificate will be sold to the highest bidder at the Sarasota County Court House, 2000 Main Street, Historic Courtroom, East Wing, Sarasota, Florida, at 9:00 a.m. on the 17TH day of JUNE, 2014.

Karen E. Rushing
Clerk Of The Circuit Court
Sarasota County, Florida
By: T. Lake, Deputy Clerk
Publication Dates: MAY 16, 23, 30;
JUNE 6, 2014

14-02198S

SECOND INSERTION

NOTICE OF FORECLOSURE SALE IN THE CIRCUIT COURT OF THE 12TH JUDICIAL CIRCUIT, IN AND FOR SARASOTA COUNTY, FLORIDA
CIVIL DIVISION:
CASE NO.: 2013 CA 004560 NC
FEDERAL NATIONAL MORTGAGE ASSOCIATION, Plaintiff, vs.
TOSIL ALI A/K/A TOSIL PAUL ALI; UNKNOWN TENANT IN POSSESSION OF THE SUBJECT PROPERTY, Defendants.

NOTICE IS HEREBY GIVEN pursuant to Final Judgment of Foreclosure dated the 5th day of May, 2014, and entered in Case No. 2013 CA 004560 NC, of the Circuit Court of the 12TH Judicial Circuit in and for Sarasota County, Florida, wherein FEDERAL NATIONAL MORTGAGE ASSOCIATION is the Plaintiff and TOSIL ALI A/K/A TOSIL PAUL ALI and UNKNOWN TENANT (S) IN POSSESSION OF THE SUBJECT PROPERTY are defendants. The Clerk of this Court shall sell to the highest and best bidder for cash electronically at www.sarasota.realforeclose.com at 9:00 AM on the 6th day of June, 2014, the following described property as set forth in said Final Judgment, to wit:

LOT 10, BLOCK 1739, 34TH ADDITION TO PORT CHARLOTTE SUBDIVISION, A SUBDIVISION ACCORDING TO THE PLAT THEREOF AS RECORDED IN PLAT BOOK 15, PAGES 18, 18A-18M, OF THE PUBLIC RECORDS OF SARASOTA COUNTY, FLORIDA
ANY PERSON CLAIMING AN INTEREST IN THE SURPLUS FROM THE SALE, IF ANY, OTHER THAN THE PROPERTY OWNER AS OF THE DATE OF THE LIS PENDENS MUST FILE A CLAIM WITHIN 60 DAYS AFTER THE SALE.

If you are a person with a disability who needs any accommodation in order to participate in this proceeding, you are entitled, at no cost to you, to the provision of certain assistance. Please contact the Sarasota County Jury Office, P.O. Box 3079, Sarasota, Florida 34230-3079, (941)861-7400, at least seven (7) days before your scheduled court appearance, or immediately upon receiving this notification if the time before the scheduled appearance is less than seven (7) days; if you are hearing or voice impaired, call 711.

Dated this 8 day of May, 2014.
By: Jennifer Nicole Tarquinio
Bar #99192

Choice Legal Group, P.A.
P.O. Box 9908
Fort Lauderdale, FL 33310-0908
Telephone: (954) 453-0365
Facsimile: (954) 771-6052
Toll Free: 1-800-441-2438
DESIGNATED PRIMARY E-MAIL FOR SERVICE PURSUANT TO FLA R. JUD. ADMIN 2.516
eservice@clegalgroup.com
11-19642
May 16, 23, 2014

14-02097S

SECOND INSERTION

NOTICE OF FORECLOSURE SALE IN THE CIRCUIT COURT OF THE 12TH JUDICIAL CIRCUIT, IN AND FOR SARASOTA COUNTY, FLORIDA
CIVIL DIVISION:
CASE NO.: 2013 CA 002253 NC
FEDERAL NATIONAL MORTGAGE ASSOCIATION, Plaintiff, vs.
JOSE FEBUS; THE DUCK KEY OWNERS' ASSOCIATION, INC.; NELIDA MALDONADO; UNKNOWN TENANT IN POSSESSION OF THE SUBJECT PROPERTY, Defendants.

NOTICE IS HEREBY GIVEN pursuant to Final Judgment of Foreclosure dated the 28th day of April, 2014, and entered in Case No. 2013 CA 002253 NC, of the Circuit Court of the 12TH Judicial Circuit in and for Sarasota County, Florida, wherein FEDERAL NATIONAL MORTGAGE ASSOCIATION is the Plaintiff and JOSE FEBUS; NELIDA MALDONADO and UNKNOWN TENANT(S) IN POSSESSION OF THE SUBJECT PROPERTY are defendants. The Clerk of this Court shall sell to the highest and best bidder for cash electronically at www.sarasota.realforeclose.com at 9:00 AM on the 3rd day of June, 2014, the following described property as set forth in said Final Judgment, to wit:

LOT 8, BLOCK 497, 13TH ADDITION TO PORT CHARLOTTE SUBDIVISION, ACCORDING TO THE PLAT THEREOF, RECORDED IN PLAT BOOK 13, PAGE 12, OF THE PUBLIC RECORDS OF SARASOTA COUNTY, FLORIDA.

ANY PERSON CLAIMING AN INTEREST IN THE SURPLUS FROM THE SALE, IF ANY, OTHER THAN THE PROPERTY OWNER AS OF THE DATE OF THE LIS PENDENS MUST FILE A CLAIM WITHIN 60 DAYS AFTER THE SALE.

If you are a person with a disability who needs any accommodation in order to participate in this proceeding, you are entitled, at no cost to you, to the provision of certain assistance. Please contact the Sarasota County Jury Office, P.O. Box 3079, Sarasota, Florida 34230-3079, (941)861-7400, at least seven (7) days before your scheduled court appearance, or immediately upon receiving this notification if the time before the scheduled appearance is less than seven (7) days; if you are hearing or voice impaired, call 711.

Dated this 7 day of May, 2014.
By: Jennifer Nicole Tarquinio
Bar #99192

Choice Legal Group, P.A.
P.O. Box 9908
Fort Lauderdale, FL 33310-0908
Telephone: (954) 453-0365
Facsimile: (954) 771-6052
Toll Free: 1-800-441-2438
DESIGNATED PRIMARY E-MAIL FOR SERVICE PURSUANT TO FLA R. JUD. ADMIN 2.516
eservice@clegalgroup.com
11-14576
May 16, 23, 2014

14-02095S

SECOND INSERTION

NOTICE OF SALE IN THE CIRCUIT COURT OF THE TWELFTH JUDICIAL CIRCUIT OF THE STATE OF FLORIDA, IN AND FOR SARASOTA COUNTY
CIVIL DIVISION
CASE NO.
58-2009-CA-015235-XXXX-NC
BANK OF AMERICA, N.A., Plaintiff, vs.
THOMAS M. MAHONEY, JR.; COURTNEY J. MAHONEY; ANY AND ALL UNKNOWN PARTIES, CLAIMING BY, THROUGH, UNDER, AND AGAINST THE HEREIN NAMED INDIVIDUAL DEFENDANT(S) WHO ARE NOT KNOWN TO BE DEAD OR ALIVE, WHETHER SAID UNKNOWN PARTIES MAY CLAIM AN INTEREST AS SPOUSES, HEIRS, DEVISEES, GRANTEES, OR OTHER CLAIMANTS; JOHN DOE AND JANE DOE AS UNKNOWN TENANTS IN POSSESSION; Defendant(s)

Notice is hereby given that, pursuant to a Final Summary Judgment of Foreclosure entered on 04/02/2014 in the above-styled cause, in the Circuit Court of Sarasota County, Florida, the office of Karen E. Rushing clerk of the circuit court will sell the property situate in Sarasota County, Florida, described as:

LOT 35 BLOCK 2572, 51ST ADDITION TO PORT CHARLOTTE SUBDIVISION, A SUBDIVISION ACCORDING TO THE PLAT THEREOF, AS RECORDED IN PLAT BOOK 21 AT PAGES 8, 8A THROUGH 8GG OF THE PUBLIC RECORDS OF SARASOTA COUNTY.

at public sale, to the highest and best bidder, for cash, www.sarasota.realforeclose.com at 9:00 o'clock, A.M., on June 2, 2014

Any person claiming an interest in the surplus from the sale, if any, other than the property owner as of the date of the lis pendens, must file a claim within 60 days after the sale.

If you are a person with a disability who needs any accommodation in order to participate in this proceeding, you are entitled, at no cost to you, to the provision of certain assistance. Please contact the Sarasota County Jury Office, P.O. Box 3079, Sarasota, Florida 34230-3079, (941)861-7400, at least seven (7) days before your scheduled court appearance, or immediately upon receiving this notification if the time before the scheduled appearance is less than seven (7) days; if you are hearing or voice impaired, call 711.

ATTORNEY FOR PLAINTIFF
By /S/ Josh D. Donnelly
Josh D. Donnelly
Florida Bar #64788

Date: 05/08/2014
THIS INSTRUMENT PREPARED BY:
Law Offices Of Daniel C. Consuegra
9204 King Palm Drive
Tampa, FL 33619-1328
Phone: 813-915-8660
Attorneys for Plaintiff
157003
May 16, 23, 2014

14-02124S

SECOND INSERTION

NOTICE OF FORECLOSURE SALE IN THE CIRCUIT COURT OF THE TWELFTH JUDICIAL CIRCUIT, IN AND FOR SARASOTA COUNTY, FLORIDA
CIVIL DIVISION
CASE NO.: 2013 CA 006312 NC
JPMORGAN CHASE BANK, NATIONAL ASSOCIATION, Plaintiff, vs.
CHERYL C. LEE A/K/A CHERYL LEE, et al
Defendants.

NOTICE IS HEREBY GIVEN pursuant to a Summary Final Judgment of foreclosure dated May 05, 2014, and entered in Case No. 2013 CA 006312 NC of the Circuit Court of the TWELFTH Judicial Circuit in and for SARASOTA COUNTY, Florida, wherein JPMORGAN CHASE BANK, NATIONAL ASSOCIATION, is Plaintiff, and CHERYL C. LEE A/K/A CHERYL LEE, et al are Defendants, the clerk will sell to the highest and best bidder for cash, beginning at 09:00 AM at www.sarasota.realforeclose.com, in accordance with Chapter 45, Florida Statutes, on the 18 day of June, 2014, the following described property as set forth in said Summary Final Judgment, to wit:

LOT 24, BLOCK 2612 52ND ADDITION TO PORT CHARLOTTE SUBDIVISION ACCORDING TO MAP OR PLAT THEREOF AS RECORDED IN PLAT O.R BOOK 21, PAGE 13 OF THE PUBLIC RECORDS OF SARASOTA COUNTY, FLORIDA.

Any person claiming an interest in the surplus funds from the sale, if any, other than the property owner as of the date of the lis pendens must file a claim within 60 days after the sale.

If you are a person with a disability who needs any accommodation in order to participate in this proceeding, you are entitled, at no cost to you, to the provision of certain assistance. Please contact the Sarasota County Jury Office, P.O. Box 3079, Sarasota, Florida 34230-3079, (941)861-7400, at least seven (7) days before your scheduled court appearance, or immediately upon receiving this notification if the time before the scheduled appearance is less than seven (7) days; if you are hearing or voice impaired, call 711.

Dated: May 8, 2014
By: /s/ Heather J. Koch
Phelan Hallinan, PLC
Heather J. Koch, Esq.,
Florida Bar No. 89107
Emilio R. Lenzi, Esq.,
Florida Bar No. 0668273

JPMORGAN CHASE BANK, NATIONAL ASSOCIATION
c/o Phelan Hallinan, PLC
Attorneys for Plaintiff
2727 West Cypress Creek Road
Ft. Lauderdale, FL 33309
Tel: 954-462-7000
Fax: 954-462-7001
Service by email:
FL.Service@PhelanHallinan.com
PH # 44098
May 16, 23, 2014

14-02102S

SECOND INSERTION

NOTICE OF SALE IN THE CIRCUIT COURT OF THE TWELFTH JUDICIAL CIRCUIT IN AND FOR SARASOTA COUNTY, FLORIDA
Case No. 2013 CA 003319 NC
UKRAINIAN SELFRELANCE MICHIGAN FEDERAL CREDIT UNION, Plaintiff, v.
SERGIO KLIMANTOVICH and TAMARA KLIMANTOVICH, and ROBERT P. WINFREY and RENA E. WINFREY and VIKTOR KLIMANTOVICH
Defendants.

Notice is hereby given pursuant to the final judgment of foreclosure entered in the above noted case, that I will sell the following property situated in Sarasota County, Florida, described as:

Lot 27, Block 212, 16th Addition to Port Charlotte Subdivision, as per Plat thereof recorded in Plat Book 11, Pages 34, 34A through 34G, of the Public Records of Sarasota County, Florida

Parcel Id No. 1006021227
at public sale, to the highest and best bidder for cash, on-line at www.sarasota.realforeclose.com, at 9:00 a.m. on June 12, 2014. The highest bidder shall immediately post with the Clerk, a deposit equal to 5% of the final bid or one thousand dollars (\$1,000.00) whichever is less. The deposit must be cash or cashier's check payable to the Clerk of Court. Final payment must be made on or before 5:00 p.m. of the date of the sale by cash or cashier's check.

If you are a person with a disability

who needs any accommodation in order to participate in this proceeding, you are entitled, at no cost to you, to the provision of certain assistance. Please contact the Sarasota County Jury Office, P.O. Box 3079, Sarasota, Florida 34230-3079, (941)861-7400, at least seven (7) days before your scheduled court appearance, or immediately upon receiving this notification if the time before the scheduled appearance is less than seven (7) days; if you are hearing or voice impaired, call 711.

Dated: May 12, 2014
Attorney for Plaintiff:
DOUGLAS W. GRISSINGER,
ESQUIRE
MELLOR & GRISSINGER
13801-D Tamiami Trail
North Port, Florida 34287
May 16, 23, 2014

SECOND INSERTION

NOTICE OF SALE IN THE CIRCUIT COURT OF THE TWELFTH JUDICIAL CIRCUIT OF THE STATE OF FLORIDA, IN AND FOR SARASOTA COUNTY
CIVIL DIVISION
CASE NO.
58-2009-CA-014712-XXXX-NC
BAC HOME LOANS SERVICING, L.P F/K/A COUNTRYWIDE HOME LOANS SERVICING LP,, Plaintiff, vs.
PETRU STANCIU; OFELIA SANTCIU; ANY AND ALL UNKNOWN PARTIES, CLAIMING BY, THROUGH, UNDER, AND AGAINST THE HEREIN NAMED INDIVIDUAL DEFENDANT(S) WHO ARE NOT KNOWN TO BE DEAD OR ALIVE, WHETHER SAID UNKNOWN PARTIES MAY CLAIM AN INTEREST AS SPOUSES, HEIRS, DEVISEES, GRANTEES, OR OTHER CLAIMANTS; JOHN DOE; JANE DOE; Defendant(s)

Notice is hereby given that, pursuant to a Final Summary Judgment of Foreclosure entered on in the above styled cause, in the Circuit Court of Sarasota County, Florida, the office of Karen E. Rushing clerk of the circuit court will sell the property situate in Sarasota County, Florida, described as:

LOTS 8892, 8893 AND 8894, SOUTH VENICE, UNIT NO. 32 AS PER PLAT THEREOF AS RECORDED IN PLAT BOOK 6 PAGE 86, OF THE PUBLIC RECORDS OF SARASOTA COUNTY, FLORIDA.

at public sale, to the highest and best bidder, for cash, www.sarasota.realforeclose.com at 9:00 o'clock, A.M., on June 5, 2014

Any person claiming an interest in the surplus from the sale, if any, other than the property owner as of the date of the lis pendens, must file a claim within 60 days after the sale.

If you are a person with a disability who needs any accommodation in order to participate in this proceeding, you are entitled, at no cost to you, to the provision of certain assistance. Please contact the Sarasota County Jury Office, P.O. Box 3079, Sarasota, Florida 34230-3079, (941)861-7400, at least seven (7) days before your scheduled court appearance, or immediately upon receiving this notification if the time before the scheduled appearance is less than seven (7) days; if you are hearing or voice impaired, call 711.

ATTORNEY FOR PLAINTIFF
By /S/ Josh D. Donnelly
Josh D. Donnelly
Florida Bar #64788

Date: 05/09/2014
THIS INSTRUMENT PREPARED BY:
Law Offices Of Daniel C. Consuegra
9204 King Palm Drive
Tampa, FL 33619-1328
Phone: 813-915-8660
Attorneys for Plaintiff
156917
May 16, 23, 2014

14-02141S

SECOND INSERTION

NOTICE OF SALE IN THE CIRCUIT COURT OF THE TWELFTH JUDICIAL CIRCUIT OF THE STATE OF FLORIDA, IN AND FOR SARASOTA COUNTY
CIVIL DIVISION
CASE NO.
58-2009-CA-009428-XXXX-NC
CAPITAL ONE, N.A., Plaintiff, vs.
CHARLES E. SPRY, JR.; UNKNOWN SPOUSE OF CHARLES E. SPRY, JR.; LINDA B. SPRY A/K/A LINDA BROEL SPRY; UNKNOWN SPOUSE OF LINDA B. SPRY A/K/A LINDA BROEL SPRY; IF LIVING, INCLUDING ANY UNKNOWN SPOUSE OF SAID DEFENDANT(S), IF REMARRIED, AND IF DECEASED, THE RESPECTIVE UNKNOWN HEIRS, DEVISEES, GRANTEES, ASSIGNEES, CREDITORS, LIENORS, AND TRUSTEES, AND ALL OTHER PERSONS CLAIMING BY, THROUGH, UNDER OR AGAINST THE NAMED DEFENDANT(S); FLAGSHIP NATIONAL BANK; WHETHER DISSOLVED OR PRESENTLY EXISTING, TOGETHER WITH ANY GRANTEES, ASSIGNEES, CREDITORS, LIENORS, OR TRUSTEES OF SAID DEFENDANT(S) AND ALL OTHER PERSONS CLAIMING BY, THROUGH, UNDER, OR AGAINST DEFENDANT(S); UNKNOWN TENANT #1; UNKNOWN TENANT #2; Defendant(s)

Notice is hereby given that, pursuant to a Final Summary Judgment of Foreclosure entered on 04/07/2014 in the above styled cause, in the Circuit Court of Sarasota County, Florida, the office of Karen E. Rushing clerk of the circuit court will sell the property situate in Sarasota County, Florida, described as:

BEGIN AT THE SOUTHWEST CORNER OF BLOCK 64, ACCORDING TO THE PLAT NO. 3, JOHN RINGLING ESTATES, INC., LIDO BEACH

DIVISION B, AS PER PLAT THEREOF IN PLAT BOOK 2, PAGE 207, OF THE PUBLIC RECORDS OF SARASOTA COUNTY, FLORIDA; THENCE RUN NORTHERLY ALONG WEST BOUNDARY LINE OF BLOCK 64, A DISTANCE OF 182 FEET FOR A POINT OF BEGINNING; THENCE RUN EASTERLY 160 FEET; THENCE RUN NORTHERLY 70 FEET; THENCE WESTERLY 160 FEET TO THE WEST SIDE OF BLOCK 64; THENCE SOUTHERLY 70 FEET TO THE POINT OF BEGINNING.

at public sale, to the highest and best bidder, for cash, www.sarasota.realforeclose.com at 9:00 o'clock, A.M., on June 6, 2014

Any person claiming an interest in the surplus from the sale, if any, other than the property owner as of the date of the lis pendens, must file a claim within 60 days after the sale.

If you are a person with a disability who needs any accommodation in order to participate in this proceeding, you are entitled, at no cost to you, to the provision of certain assistance. Please contact the Sarasota County Jury Office, P.O. Box 3079, Sarasota, Florida 34230-3079, (941)861-7400, at least seven (7) days before your scheduled court appearance, or immediately upon receiving this notification if the time before the scheduled appearance is less than seven (7) days; if you are hearing or voice impaired, call 711.

ATTORNEY FOR PLAINTIFF
By /S/ Josh D. Donnelly
Josh D. Donnelly
Florida Bar #64788

Date: 05/09/2014
THIS INSTRUMENT PREPARED BY:
Law Offices Of Daniel C. Consuegra
9204 King Palm Drive
Tampa, FL 33619-1328
Phone: 813-915-8660
Attorneys for Plaintiff
43039
May 16, 23, 2014

14-02142S

NOTICE OF SALE IN THE CIRCUIT COURT OF THE TWELFTH JUDICIAL CIRCUIT OF THE STATE OF FLORIDA, IN AND FOR SARASOTA COUNTY
CIVIL DIVISION
CASE NO.
58-2012-CA-001936-0000-NC
HSBC BANK USA, NATIONAL ASSOCIATION AS TRUSTEE FOR OPTIMUM MORTGAGE ACCEPTANCE CORPORATION, ASSET-BACKED PASS-THROUGH CERTIFICATES, SERIES 2005-5, Plaintiff, vs.
FREDERICK G. SANDERS, III; UNKNOWN SPOUSE OF FREDERICK G. SANDERS, III; IF LIVING, INCLUDING ANY UNKNOWN SPOUSE OF SAID DEFENDANT(S), IF REMARRIED, AND IF DECEASED, THE RESPECTIVE UNKNOWN HEIRS, DEVISEES, GRANTEES, ASSIGNEES, CREDITORS, LIENORS, AND TRUSTEES, AND ALL OTHER PERSONS CLAIMING BY, THROUGH, UNDER OR AGAINST THE NAMED DEFENDANT(S); SUNTRUST BANK; DICKINSON FINANCIAL, LLC, AS SUCCESSOR IN INTEREST

Notice is hereby given that, pursuant to a Final Summary Judgment of Foreclosure entered on 04/21/2014 in the above styled cause, in the Circuit Court of Sarasota County, Florida, the office of Karen E. Rushing clerk of the circuit court will sell the property situate in Sarasota County, Florida, described as:

Lot 3, LESS the Southerly 8 feet and all of Lot 4, Block D, PALM GROVE, according to the plat thereof, as recorded in Plat Book 1, Page 69, of the Public Records of Sarasota County, Florida. LESS road right of way as set forth in Official Records Book 403, Page 403 of said Public Records.

at public sale, to the highest and best bidder, for cash, www.sarasota.realforeclose.com at 9:00 o'clock, A.M., on

May 28, 2014

Any person claiming an interest in the surplus from the sale, if any, other than the property owner as of the date of the lis pendens, must file a claim within 60 days after the sale.

If you are a person with a disability who needs any accommodation in order to participate in this proceeding, you are entitled, at no cost to you, to the provision of certain assistance. Please contact the Sarasota County Jury Office, P.O. Box 3079, Sarasota, Florida 34230-3079, (941)861-7400, at least seven (7) days before your scheduled court appearance, or immediately upon receiving this notification if the time before the scheduled appearance is less than seven (7) days; if you are hearing or voice impaired, call 711.

ATTORNEY FOR PLAINTIFF
By /S/ Josh D. Donnelly
Josh D. Donnelly
Florida Bar #64788

Date: 05/09/2014
THIS INSTRUMENT PREPARED BY:
Law Offices Of Daniel C. Consuegra
9204 King Palm Drive
Tampa, FL 33619-1328
Phone: 813-915-8660
Attorneys for Plaintiff
116113
May 16, 23, 2014

14-02147S

HOW TO PUBLISH YOUR LEGAL NOTICE IN THE BUSINESS OBSERVER

FOR MORE INFORMATION, CALL:

Hillsborough, Pasco
(813) 221-9505

Pinellas
(727) 447-7784

Manatee, Sarasota, Lee
(941) 906-9386

Orange County
(407) 654-5500

Collier
(239) 263-0122

Charlotte
(941) 249-4900

Or e-mail:
legal@businessobserverfl.com

Business Observer
LV4658

SECOND INSERTION

NOTICE OF SALE IN THE CIRCUIT COURT OF THE TWELFTH JUDICIAL CIRCUIT OF THE STATE OF FLORIDA, IN AND FOR SARASOTA COUNTY CIVIL DIVISION CASE NO.

58-2013-CA-001443-XXXX-NC GREEN TREE SERVICING LLC, Plaintiff, vs. DIANE SOMES; UNKNOWN SPOUSE OF DIANE SOMES; TERRY A. SOMES; UNKNOWN SPOUSE OF TERRY A. SOMES; THE BANK OF NEW YORK MELLON F/K/A THE BANK OF NEW YORK, AS SUCCESSOR TRUSTEE TO JPMORGAN CHASE BANK, NATIONAL ASSOCIATION, AS TRUSTEE FOR THE CERTIFICATEHOLDERS OF CWABS MASTER TRUST REVOLVING HOME EQUITY LOAN ASSET BACKED NOTES, SERIES 2004-T; UNKNOWN TENANT #1; UNKNOWN TENANT #2;

Defendant(s)

Notice is hereby given that, pursuant to a Final Summary Judgment of Foreclosure entered on 04/21/2014 in the above styled cause, in the Circuit Court of Sarasota County, Florida, the office of Karen E. Rushing clerk of the circuit court will sell the property situate in Sarasota County, Florida, described as: LOT 16, BLOCK 1200, 35TH ADDITION TO PORT CHARLOTTE SUBDIVISION, ACCORDING TO THE PLAT THEREOF, AS RECORDED IN PLAT BOOK 15, PAGE 19, OF THE PUBLIC RECORDS OF SARASOTA COUNTY, FLORIDA.

at public sale, to the highest and best bidder, for cash, www.sarasota.realforeclose.com at 9:00 o'clock, A.M., on May 29, 2014

Any person claiming an interest in the surplus from the sale, if any, other than the property owner as of the date of the lis pendens, must file a claim within 60 days after the sale.

If you are a person with a disability who needs any accommodation in order to participate in this proceeding, you are entitled, at no cost to you, to the provision of certain assistance. Please contact the Sarasota County Jury Office, P.O. Box 3079, Sarasota, Florida 34230-3079, (941)861-7400, at least seven (7) days before your scheduled court appearance, or immediately upon receiving this notification if the time before the scheduled appearance is less than seven (7) days; if you are hearing or voice impaired, call 711.

ATTORNEY FOR PLAINTIFF

By /s/ Josh D. Donnelly
Josh D. Donnelly
Florida Bar #64788

Date: 05/12/2014
THIS INSTRUMENT PREPARED BY:
Law Offices Of Daniel C. Consuegra
9204 King Palm Drive
Tampa, FL 33619-1328
Phone: 813-915-8660
Attorneys for Plaintiff
141603
May 16, 23, 2014 14-02144S

SECOND INSERTION

NOTICE OF FORECLOSURE SALE IN THE CIRCUIT COURT OF THE TWELFTH JUDICIAL CIRCUIT IN AND FOR

SARASOTA COUNTY, FLORIDA CASE NO.: 2013 CA 002522 NC FEDERAL NATIONAL MORTGAGE ASSOCIATION, Plaintiff, vs. THOMAS C. COULOMBE; TIFFANY K. DAUSON; UNKNOWN SPOUSE OF THOMAS C. COULOMBE; UNKNOWN SPOUSE OF TIFFANY K. DAUSON; JOCKEY CLUB OF NORTH PORT PROPERTY OWNERS' ASSOCIATION, INC.; UNKNOWN TENANT(S) IN POSSESSION #1 and #2, and ALL OTHER UNKNOWN PARTIES, et al.,

Defendant(s). NOTICE IS HEREBY GIVEN pursuant to a Final Summary Judgment of Foreclosure dated May 06, 2014, entered in Civil Case No.: 2013 CA 002522 NC of the Circuit Court of the Twelfth Judicial Circuit in and for Sarasota County, Florida, wherein FEDERAL NATIONAL MORTGAGE ASSOCIATION, Plaintiff, and THOMAS C. COULOMBE; TIFFANY K. DAUSON; JOCKEY CLUB OF NORTH PORT PROPERTY OWNERS' ASSOCIATION, INC.; UNKNOWN TENANT(S) IN POSSESSION # 1 N/K/A HEATHER L. BINGLE, are Defendants.

KAREN E. RUSHING, The Clerk of the Circuit Court, will sell to the highest bidder for cash, www.sarasota.realforeclose.com, at 09:00 AM, on the 10th day of June, 2014, the following described real property as set forth in said Final Summary Judgment, to wit:

LOT 20, BLOCK 2643, OF 52ND ADDITION TO PORT CHARLOTTE SUBDIVISION, ACCORDING TO THE PLAT THEREOF AS RECORDED IN PLAT BOOK 21, PAGE 13 OF THE PUBLIC RECORDS OF SARASOTA COUNTY, FLORIDA.

SECOND INSERTION

NOTICE OF SALE IN THE CIRCUIT COURT OF THE TWELFTH JUDICIAL CIRCUIT OF THE STATE OF FLORIDA, IN AND FOR SARASOTA COUNTY CIVIL DIVISION CASE NO.

58-2013-CA-005307-XXXX-NC GREEN TREE SERVICING LLC, Plaintiff, vs. UNKNOWN HEIRS, DEVISEES, GRANTEES, ASSIGNEES, CREDITORS, LIENORS, TRUSTEES OF ROBERT T. GOODMAN, II, DECEASED; JOYCE ROVENGO, AS PERSONAL REPRESENTATIVE OF THE ESTATE OF ROBERT T. GOODMAN, II; JOYCE ROVENGO, HEIR; GENEVA G. GOODMAN, HEIR; PATRICIA LEE DIGIACOMO, HEIR; WELLS FARGO BANK, N.A., SUCCESSOR BY MERGER TO WACHOVIA BANK, NATIONAL ASSOCIATION; UNKNOWN TENANT #1; UNKNOWN TENANT #2;

Defendant(s)

Notice is hereby given that, pursuant to a Final Summary Judgment of Foreclosure entered on 04/21/2014 in the above styled cause, in the Circuit Court of Sarasota County, Florida, the office of Karen E. Rushing clerk of the circuit court will sell the property situate in Sarasota County, Florida, described as: LOT 65, PAVER PARK ESTATES, SECOND ADDITION, ACCORDING TO THE PLAT THEREOF, AS RECORDED IN PLAT BOOK 7, PAGE 95, OF THE PUBLIC RECORDS OF SARASOTA COUNTY, FLORIDA.

at public sale, to the highest and best bidder, for cash, www.sarasota.realforeclose.com at 9:00 o'clock, A.M., on May 28, 2014

Any person claiming an interest in the surplus from the sale, if any, other than the property owner as of the date of the lis pendens, must file a claim within 60 days after the sale.

If you are a person with a disability who needs any accommodation in order to participate in this proceeding, you are entitled, at no cost to you, to the provision of certain assistance. Please contact the Sarasota County Jury Office, P.O. Box 3079, Sarasota, Florida 34230-3079, (941)861-7400, at least seven (7) days before your scheduled court appearance, or immediately upon receiving this notification if the time before the scheduled appearance is less than seven (7) days; if you are hearing or voice impaired, call 711.

ATTORNEY FOR PLAINTIFF

By /s/ Josh D. Donnelly
Josh D. Donnelly
Florida Bar #64788

Date: 05/09/2014
THIS INSTRUMENT PREPARED BY:
Law Offices Of Daniel C. Consuegra
9204 King Palm Drive
Tampa, FL 33619-1328
Phone: 813-915-8660
Attorneys for Plaintiff
141784
May 16, 23, 2014 14-02145S

SECOND INSERTION

NOTICE OF FORECLOSURE SALE IN THE CIRCUIT COURT OF THE 12TH JUDICIAL CIRCUIT, IN AND FOR SARASOTA COUNTY, FLORIDA.

CASE No. 58-2009-CA-019590 NC THE BANK OF NEW YORK MELLON FKA THE BANK OF NEW YORK, AS TRUSTEE FOR THE CERTIFICATEHOLDERS CWABS, INC., ASSET BACKED CERTIFICATES SERIES 2005-16, Plaintiff, vs. HOUSTON M. PARRISH et al., Defendants.

NOTICE IS HEREBY GIVEN pursuant to an Order or Final Judgment entered in Case No. 58-2009-CA-019590 NC of the Circuit Court of the 12TH Judicial Circuit in and for SARASOTA County, Florida, wherein, THE BANK OF NEW YORK MELLON FKA THE BANK OF NEW YORK, AS TRUSTEE FOR THE CERTIFICATEHOLDERS CWABS, INC., ASSET BACKED CERTIFICATES SERIES 2005-16, Plaintiff, and, HOUSTON M. PARRISH, et. al, are Defendants, the Clerk of Courts will sell to the highest bidder for cash at, FORECLOSURE SALE TO BE CONDUCTED VIA THE INTERNET: WWW.SARASOTA.REALFORECLOSE.COM, at the hour of 9:00 A.M., on the 4th day of June, 2014, the following described property:

LOT 33, BLOCK B, LEISURE LAKES, UNIT 3, ACCORDING TO THE PLAT THEREOF RECORDED IN PLAT BOOK 9, PAGE 29, PUBLIC RECORDS OF SARASOTA COUNTY, FLORIDA.

Property Address: 2135 CHRYSLER AVE, SARASOTA, FL 34234

Any person claiming an interest in the surplus from the sale, if any, other than the property owner as of the date of the lis pendens must file a claim within 60 days after the sale.

If you are a person with a disability who needs any accommodation in order to participate in this proceeding, you are entitled, at no cost to you, to the provision of certain assistance. Please contact the Sarasota County Jury Office, P.O. Box 3079, Sarasota, Florida 34230-3079, (941)861-7400, at least seven (7) days before your scheduled court appearance, or immediately upon receiving this notification if the time before the scheduled appearance is less than seven (7) days; if you are hearing or voice impaired, call 711.

DATED This 12 day of May 2014.

By: Brandon Loshak, Esq.
Florida Bar No. 98852
for Shannon Jones, Esq.
Florida Bar No. 106419

GREENSPOON MARDER, P.A.
TRADE CENTRE SOUTH,
SUITE 700
100 WEST CYPRESS CREEK ROAD
FORT LAUDERDALE, FL 33309
Telephone: (954) 343 6273
Hearing Line: (888) 491-1120
Facsimile: (954) 343 6982
Email 1:
shannon.jones@gmlaw.com
Email 2: gmforeclosure@gmlaw.com
Matter # 29152.0308
May 16, 23, 2014 14-02162S

SECOND INSERTION

RE-NOTICE OF FORECLOSURE SALE IN THE CIRCUIT COURT OF THE 12TH JUDICIAL CIRCUIT, IN AND FOR SARASOTA COUNTY, FLORIDA

CIVIL DIVISION: CASE NO.: 2013 CA 000652 NC U.S. BANK, NATIONAL ASSOCIATION, AS TRUSTEE FOR RASC 2006-EMX4, Plaintiff, vs. CHARLES DAVID MOORE A/K/A C. DAVID MOORE; TANIA MOORE; UNKNOWN TENANT IN POSSESSION OF THE SUBJECT PROPERTY, Defendants.

NOTICE IS HEREBY GIVEN pursuant to an Order Resetting Foreclosure Sale dated the 13th day of March, 2014, and entered in Case No. 2013 CA 000652 NC, of the Circuit Court of the 12TH Judicial Circuit in and for Sarasota County, Florida, wherein U.S. BANK, NATIONAL ASSOCIATION, AS TRUSTEE FOR RASC 2006-EMX4 is the Plaintiff and CHARLES DAVID MOORE A/K/A C. DAVID MOORE; TANIA MOORE and UNKNOWN TENANT(S) IN POSSESSION OF THE SUBJECT PROPERTY are defendants. The Clerk of this Court shall sell to the highest and best bidder for cash electronically at www.sarasota.realforeclose.com at 9:00 AM on the 10th day of June, 2014, the following described property as set forth in said Final Judgment, to wit:

LOT 498, DESOTO LAKES, UNIT NO. 8, ACCORDING TO THE PLAT THEREOF RECORDED IN PLAT BOOK 9, PAGE 13, OF THE PUBLIC RECORDS OF SARASOTA COUNTY, FLORIDA.

ANY PERSON CLAIMING AN INTEREST IN THE SURPLUS FROM THE SALE, IF ANY, OTHER THAN THE PROPERTY OWNER AS OF THE DATE OF THE LIS PENDENS MUST FILE A CLAIM WITHIN 60 DAYS AFTER THE SALE.

If you are a person with a disability who needs any accommodation in order to participate in this proceeding, you are entitled, at no cost to you, to the provision of certain assistance. Please contact the Sarasota County Jury Office, P.O. Box 3079, Sarasota, Florida 34230-3079, (941)861-7400, at least seven (7) days before your scheduled court appearance, or immediately upon receiving this notification if the time before the scheduled appearance is less than seven (7) days; if you are hearing or voice impaired, call 711.

Dated This 12 day of May, 2014.

By: Jennifer Nicole Tarquinio
Bar #99192

Choice Legal Group, P.A.
P.O. Box 9908
Fort Lauderdale, FL 33310-0908
Telephone: (954) 453-0365
Facsimile: (954) 771-6052
Toll Free: 1-800-441-2438
DESIGNATED PRIMARY E-MAIL FOR SERVICE PURSUANT TO FLA R. JUD. ADMIN 2.516
eservice@clegalgroup.com
12-11705
May 16, 23, 2014 14-02161S

SECOND INSERTION

NOTICE OF FORECLOSURE SALE IN THE CIRCUIT COURT OF THE TWELFTH JUDICIAL CIRCUIT, IN AND FOR SARASOTA COUNTY, FLORIDA CIVIL DIVISION

CASE NO. :58-2013-CA-007460 NC U.S. BANK, NATIONAL ASSOCIATION, AS SUCCESSOR TRUSTEE TO BANK OF AMERICA, N.A., AS SUCCESSOR TO LASALLE BANK, N.A. AS TRUSTEE FOR THE HOLDERS OF THE MERRILL LYNCH FIRST FRANKLIN MORTGAGE LOAN ASSET-BACKED CERTIFICATES, SERIES 2007-1 Plaintiff, vs. ERICA A. STEWART, et al., Defendants.

NOTICE IS HEREBY GIVEN pursuant to an Order of Final Judgment entered in Case No. 58-2013-CA-007460 NC in the Circuit Court of the TWELFTH Judicial Circuit in and for SARASOTA County, Florida, wherein, U.S. BANK, NATIONAL ASSOCIATION, AS SUCCESSOR TRUSTEE TO BANK OF AMERICA, N.A., AS SUCCESSOR TO LASALLE BANK, N.A. AS TRUSTEE FOR THE HOLDERS OF THE MERRILL LYNCH FIRST FRANKLIN MORTGAGE LOAN TRUST, MORTGAGE LOAN ASSET-BACKED CERTIFICATES, SERIES 2007-1, Plaintiff, and, ERICA A. STEWART, et. al., are Defendants. The Clerk of Court will sell to the highest bidder for cash online at www.sarasota.realforeclose.com at the hour of 09:00AM, on the 9th day of June, 2014, the following described property:

COMMENCE AT THE N.E. CORNER OF BLOCK "B" OF MORNING SIDE SUBDIVISION, RECORDED IN PLAT BOOK 5, PAGE 37, OF THE PUBLIC RECORDS OF SARASOTA COUNTY, FLORIDA; THENCE S 89 DEG 45' 54" W, ALONG THE NORTH LINE OF SAID BLOCK "B" AND ALSO ALONG THE SOUTH R/W LINE OF SIXTH STREET (60' WIDE), 12.0 FEET FOR A POINT OF BEGINNING; THENCE CONTINUE S 89 DEG 45' 54" W, ALONG SAID LINE 70.00 FEET; THENCE S 00 DEG 10' 13" E, 108.00 FEET; THENCE N 89 DEG 45' 54" E, 70.00 FEET; THENCE N 00 DEG 10' 13" W, 108.00 FEET TO THE POINT OF BEGINNING.

Any person claiming an interest in the surplus from the sale, if any, other than the property owner as of the date of the Lis Pendens must file a claim within 60 days after the sale.

If you are a person with a disability who needs any accommodation in order to participate in this proceeding, you are entitled, at no cost to you, to the provision of certain assistance. Please contact the Sarasota County Jury Office, P.O. Box 3079, Sarasota, Florida 34230-3079, (941)861-7400, at least seven (7) days before your scheduled court appearance, or immediately upon receiving this notification if the time before the scheduled appearance is less than seven (7) days; if you are hearing or voice impaired, call 711.

DATED This 12 day of May, 2014.

MILLENNIUM PARTNERS
Attorney Name:
MATTHEW B. KLEIN, ESQ.
FL BAR NO. 73529
Attorneys for Plaintiff
Primary E-Mail Address:
service@millenniumpartners.net
21500 Biscayne Blvd.,
Suite 600
Aventura, FL 33180
Telephone: (305) 698-5839
[MP# 13-000335/13-000335-1/
STEWART/DV/May 08, 2014]
May 16, 23, 2014 14-02163S

SECOND INSERTION

NOTICE OF FORECLOSURE SALE IN THE CIRCUIT COURT OF THE TWELFTH JUDICIAL CIRCUIT, IN AND FOR SARASOTA COUNTY, FLORIDA

CIVIL DIVISION CASE NO.: 2012 CA 007511 NC U.S. BANK NATIONAL ASSOCIATION AS TRUSTEE FOR STRUCTURED ASSETS SECURITIES CORPORATION, 2004-GEL3 Plaintiff, vs. THOMAS C. GAITHER, et al Defendants.

NOTICE IS HEREBY GIVEN pursuant to a Summary Final Judgment of foreclosure dated May 5, 2014, and entered in Case No. 2012 CA 007511 NC of the Circuit Court of the TWELFTH Judicial Circuit in and for SARASOTA COUNTY, Florida, wherein U.S. BANK NATIONAL ASSOCIATION AS TRUSTEE FOR STRUCTURED ASSETS SECURITIES CORPORATION, 2004-GEL3, is Plaintiff, and THOMAS C. GAITHER, et al are Defendants, the clerk will sell to the highest and best bidder for cash, beginning at 09:00 AM at www.sarasota.realforeclose.com, in accordance with Chapter 45, Florida Statutes, on the 18 day of June, 2014, the following described property as set forth in said Summary Final Judgment, to wit:

Lot 28, Block 265, 1st Addition to Port Charlotte Subdivision, as per Plat thereof recorded in Plat Book 11, Pages 29, 29A through 29J, of the Public Records of Sarasota County, Florida.

SUBJECT TO covenants, restrictions, easements of record and taxes for the current year.

Any person claiming an interest in the surplus funds from the sale, if any, other than the property owner as of the date of the lis pendens must file a claim within 60 days after the sale.

If you are a person with a disability who needs any accommodation in order to participate in this proceeding, you are entitled, at no cost to you, to the provision of certain assistance. Please contact the Sarasota County Jury Office, P.O. Box 3079, Sarasota, Florida 34230-3079, (941)861-7400, at least seven (7) days before your scheduled court appearance, or immediately upon receiving this notification if the time before the scheduled appearance is less than seven (7) days; if you are hearing or voice impaired, call 711.

Dated: May 7, 2014

By: /s/ Heather J. Koch
Phelan Hallinan, PLC
Heather J. Koch, Esq.,
Florida Bar No. 89107
Emilio R. Lenzi, Esq.,
Florida Bar No. 0668273

U.S. BANK NATIONAL ASSOCIATION AS TRUSTEE FOR STRUCTURED ASSETS SECURITIES CORPORATION, 2004-GEL3 c/o Phelan Hallinan, PLC Attorneys for Plaintiff 2727 West Cypress Creek Road Ft. Lauderdale, FL 33309 Tel: 954-462-7000 Fax: 954-462-7001 Service by email: FL.Service@PhelanHallinan.com PH # 49440
May 16, 23, 2014 14-02103S

SECOND INSERTION

NOTICE OF FORECLOSURE SALE IN THE CIRCUIT COURT OF THE 12TH JUDICIAL CIRCUIT, IN AND FOR SARASOTA COUNTY, FLORIDA

CIVIL DIVISION: CASE NO.: 2007 CA 010520 SC COUNTRYWIDE HOME LOANS, INC., Plaintiff, vs. RUEL GROVER A/K/A RUEL A. GROVER; SUNTRUST BANK; CINDY GROVER A/K/A CINDY M. GROVER; JOHN DOE; JANE DOE AS UNKNOWN TENANT(S) IN POSSESSION OF THE SUBJECT PROPERTY, Defendants.

NOTICE IS HEREBY GIVEN pursuant to a Final Judgment of Foreclosure dated the 5th day of May, 2014, and entered in Case No. 2007 CA 010520 SC, of the Circuit Court of the 12TH Judicial Circuit in and for Sarasota County, Florida, wherein GREEN TREE SERVICING, LLC is the Plaintiff and RUEL GROVER A/K/A RUEL A. GROVER; SUNTRUST BANK; CINDY GROVER A/K/A CINDY M. GROVER and UNKNOWN TENANT(S) IN POSSESSION OF THE SUBJECT PROPERTY are defendants. The Clerk of this Court shall sell to the highest and best bidder for cash electronically at www.sarasota.realforeclose.com at 9:00 AM on the 6th day of June, 2014, the following described property as set forth in said Final Judgment, to wit:

LOTS 17 AND 18, BLOCK 561, 18TH ADDITION TO PORT CHARLOTTE SUBDIVISION, ACCORDING TO THE PLAT THEREOF, AS RECORDED IN PLAT BOOK 14, PAGES 6, 6A THROUGH 6V, OF THE PUBLIC RECORDS OF SARASOTA COUNTY, FLORIDA.

ANY PERSON CLAIMING AN INTEREST IN THE SURPLUS FROM THE SALE, IF ANY, OTHER THAN THE PROPERTY OWNER AS OF THE DATE OF THE LIS PENDENS MUST FILE A CLAIM WITHIN 60 DAYS AFTER THE SALE.

If you are a person with a disability who needs any accommodation in order to participate in this proceeding, you are entitled, at no cost to you, to the provision of certain assistance. Please contact the Sarasota County Jury Office, P.O. Box 3079, Sarasota, Florida 34230-3079, (941)861-7400, at least seven (7) days before your scheduled court appearance, or immediately upon receiving this notification if the time before the scheduled appearance is less than seven (7) days; if you are hearing or voice impaired, call 711.

Dated This 12 day of May, 2014.

By: Jennifer Nicole Tarquinio
Bar #99192

Choice Legal Group, P.A.
P.O. Box 9908
Fort Lauderdale, FL 33310-0908
Telephone: (954) 453-0365
Facsimile: (954) 771-6052
Toll Free: 1-800-441-2438
DESIGNATED PRIMARY E-MAIL FOR SERVICE PURSUANT TO FLA R. JUD. ADMIN 2.516
eservice@clegalgroup.com
07-13023
May 16, 23, 2014 14-02140S

SECOND INSERTION

NOTICE OF FORECLOSURE SALE IN THE CIRCUIT COURT OF THE TWELFTH JUDICIAL CIRCUIT IN AND FOR SARASOTA COUNTY, FLORIDA

GENERAL JURISDICTION DIVISION Case No. 2011-CA-010034 NC The Bank of New York Mellon f/k/a The Bank of New York, as Trustee for the Certificateholders of CWALT, Inc. Alternative Loan Trust 2005-31, Mortgage Pass-Through Certificates, Series 2005-31, Plaintiff, vs. Frank A Bell; et al. Defendants.

NOTICE IS HEREBY GIVEN pursuant to a Final Judgment of Foreclosure dated April 29, 2014, entered in Case No. 2011-CA-010034 NC of the Circuit Court of the Twelfth Judicial Circuit, in and for Sarasota County, Florida, wherein The Bank of New York Mellon f/k/a the Bank of New York, as Trustee for the Certificateholders of CWALT, Inc. Alternative Loan Trust 2005-31, Mortgage Pass-Through Certificates, Series 2005-31 is the Plaintiff and Frank A Bell; Patricia A Bell; Any and All Unknown Parties Claiming By, Through, Under, and Against the Herein Named Individual Defendant(s) Who Are Not Known to be Dead or Alive, Whether Said Unknown Parties May Claim an Interest as Spouses, Heirs, Devisees, Grantees, or Other Claimants; Countrywide Home Loans, Inc.; Tenant #1; Tenant #2; Tenant #3; and Tenant #4 the names being fictitious to account for parties in possession are the Defendants, that the Clerk of Courts will sell to the highest and best bidder for cash by electronic sale at www.sarasota.realforeclose.com, beginning at 9:00 AM on the 3rd day of June, 2014, the following described property as set forth in said Final Judgment, to wit:

LOT 977, RIDGEWOOD ESTATES, 18TH ADDITION, ACCORDING TO THE PLAT THEREOF AS RECORDED IN PLAT BOOK 23, PAGES 8, 8A AND 8B, OF THE PUBLIC RECORDS OF SARASOTA COUNTY, FLORIDA.

Any person claiming an interest in the surplus from the sale, if any, other than the property owner as of the date of the lis pendens must file a claim within 60 days after the sale.

If you are a person with a disability who needs any accommodation in order to participate in this proceeding, you are entitled, at no cost to you, to the provision of certain assistance. Please contact the Sarasota County Jury Office, P.O. Box 3079, Sarasota, Florida 34230-3079, (941)861-7400, at least seven (7) days before your scheduled court appearance, or immediately upon receiving this notification if the time before the scheduled appearance is less than seven (7) days; if you are hearing or voice impaired, call 711.

Dated This 8 day of May, 2014.

By Kathleen McCarthy, Esq.
Florida Bar No. 72161
BROCK & SCOTT, PLLC
Attorney for Plaintiff
1501 N.W. 49th Street, Suite 200
Ft. Lauderdale, FL 33309
Phone: (954) 618-6955, ext. 6177
Fax: (954) 618-6954
FLCourtDocs@brockandscott.com
File # 13-F04592
May 16, 23, 2014 14-02126S

SECOND INSERTION

NOTICE TO CREDITORS
IN THE CIRCUIT COURT OF THE
TWELFTH JUDICIAL CIRCUIT IN
AND FOR SARASOTA COUNTY,
FLORIDA

PROBATE AND GUARDIANSHIP
DIVISION
FILE NO. 2014-CP-001661-NC

IN THE ESTATE OF
SARA S. WEBB A/K/A
SARA SPURLIN WEBB
A/K/A SARA WEBB

A/K/A SALLY WEBB, Deceased.
The administration of the estate of Sara S. Webb A/K/A Sara Spurlin Webb A/K/A Sara Webb A/K/A Sally Webb, deceased, whose date of death was April 12, 2014, is pending in the Circuit Court for Sarasota County, Florida, Probate and Guardianship Division, File Number 2014-CP-001661-NC, the address of which is P.O. Box 3079, Sarasota, Florida 34230-3079. The names and addresses of the personal representative and the personal representative's attorney are set forth below.

All creditors of the decedent and other persons, who have claims or demands against decedent's estate, including unmatured, contingent or unliquidated claims, and who have been served a copy of this notice, must file their claims with this Court WITHIN THE LATER OF THREE (3) MONTHS AFTER THE DATE OF THE FIRST PUBLICATION OF THIS NOTICE OR THIRTY (30) DAYS AFTER THE DATE OF SERVICE OF A COPY OF THIS NOTICE ON THEM.

All other creditors of the decedent and other persons having claims or demands against the decedent's estate, including unmatured, contingent or unliquidated claims, must file their claims with this Court WITHIN THREE (3) MONTHS AFTER THE DATE OF THE FIRST PUBLICATION OF THIS NOTICE.

ALL CLAIMS NOT SO FILED WILL BE FOREVER BARRED.

NOTWITHSTANDING THE TIME PERIODS SET FORTH ABOVE, ANY CLAIM FILED TWO (2) YEARS OR MORE AFTER THE DECEDENT'S DATE OF DEATH IS BARRED.

THE DATE OF FIRST PUBLICATION OF THIS NOTICE IS May 16, 2014.

Personal Representative:
Buckner G. Webb
c/o Neil W. Scott

Attorney for the Personal Representative
Neil W. Scott
FBN 0402575
1800 Second Street, Suite 818
Sarasota, FL 34236
Tel. (941) 906-8555
Email address: neil@nwscott.com
Secondary email address for service: service@nwscott.com
May 16, 23, 2014 14-02155S

SECOND INSERTION

NOTICE TO CREDITORS
IN THE CIRCUIT COURT FOR
SARASOTA COUNTY, FLORIDA
PROBATE DIVISION
FILE NO. 2014CP1714NC

Division PROBATE
IN RE: ESTATE OF
DOLORES MOJA ALVINO,
Deceased.

The administration of the estate of Dolores Moja Alvino, deceased, whose date of death was March 21st, 2014, is pending in the Circuit Court for Sarasota County, Florida, Probate Division, the address of which is P.O. Box 3079, Sarasota, Florida 34230. The names and addresses of the personal representative and the personal representative's attorney are set forth below.

All creditors of the decedent and other persons having claims or demands against decedent's estate on whom a copy of this notice is required to be served must file their claims with this court ON OR BEFORE THE LATER OF 3 MONTHS AFTER THE TIME OF THE FIRST PUBLICATION OF THIS NOTICE OR 30 DAYS AFTER THE DATE OF SERVICE OF A COPY OF THIS NOTICE ON THEM.

All other creditors of the decedent and other persons having claims or demands against decedent's estate must file their claims with this court WITHIN 3 MONTHS AFTER THE DATE OF THE FIRST PUBLICATION OF THIS NOTICE.

ALL CLAIMS NOT FILED WITHIN THE TIME PERIODS SET FORTH IN SECTION 733.702 OF THE FLORIDA PROBATE CODE WILL BE FOREVER BARRED.

NOTWITHSTANDING THE TIME PERIODS SET FORTH ABOVE, ANY CLAIM FILED TWO (2) YEARS OR MORE AFTER THE DECEDENT'S DATE OF DEATH IS BARRED.

The date of first publication of this notice is May 16, 2014.

Personal Representative:
Mignon Natasha Snider
4874 Fallcrest Circle,
Sarasota, FL 34232

ROBERT W. DARNELL
ATTORNEY AT LAW
Attorneys for Personal Representative
2639 FRUITVILLE ROAD
SUITE 201
SARASOTA, FL 34237
Florida Bar No. 0611999
May 16, 23, 2014 14-02172S

SECOND INSERTION

NOTICE TO CREDITORS
IN THE CIRCUIT COURT FOR
SARASOTA COUNTY, FLORIDA
PROBATE DIVISION
FILE NO. 2014-CP-001560-SC

IN RE: ESTATE OF
CYNTHIA D. LYONS A/K/A
CYNTHIA DUFF LYONS,
Deceased.

The administration of the estate of CYNTHIA D. LYONS A/K/A CYNTHIA DUFF LYONS, deceased, whose date of death was February 22, 2014; File Number 2014-CP-001560-SC, is pending in the Circuit Court for Sarasota County, Florida, Probate Division, the address of which is 4000 South Tamiami Trail, Venice, Florida 34293. The names and addresses of the personal representative and the personal representative's attorney are set forth below.

All creditors of the decedent and other persons having claims or demands against decedent's estate, on whom a copy of this notice is required to be served, must file their claims with this court WITHIN THE LATER OF 3 MONTHS AFTER THE TIME OF THE FIRST PUBLICATION OF THIS NOTICE OR 30 DAYS AFTER THE DATE OF SERVICE OF A COPY OF THIS NOTICE ON THEM.

All other creditors of the decedent and other persons having claims or demands against decedent's estate must file their claims with this court WITHIN 3 MONTHS AFTER THE DATE OF THE FIRST PUBLICATION OF THIS NOTICE.

ALL CLAIMS NOT FILED WITHIN THE TIME PERIODS SET FORTH IN SECTION 733.702 OF THE FLORIDA PROBATE CODE WILL BE FOREVER BARRED.

NOTWITHSTANDING THE TIME PERIOD SET FORTH ABOVE, ANY CLAIM FILED TWO (2) YEARS OR MORE AFTER THE DECEDENT'S DATE OF DEATH IS BARRED.

The date of first publication of this notice is May 16, 2014.

Signed on 4/8/14.
/s/ WILLIAM D. SKELTON
Personal Representative
2533 Nelms Drive
Decatur, Georgia 30033

William E. Gaylor, III,
Attorney for Personal Representative
Email: chip.gaylor@mgsrlaw.com
Florida Bar No. 0834350
Muirhead, Gaylor, Steves & Waskom, P.A.
901 Ridgewood Avenue
Venice, Florida 34285
Telephone: 941-484-3000
May 16, 23, 2014 14-02207S

SECOND INSERTION

NOTICE TO CREDITORS
IN THE CIRCUIT COURT FOR
SARASOTA COUNTY, FLORIDA
PROBATE DIVISION
FILE NO. 2014CP-1514-NC

IN RE: ESTATE OF
RONALD S. FILO,
Deceased.

The administration of the estate of RONALD S. FILO, deceased, whose date of death was February 17, 2014; File Number 2014-1514-CP, is pending in the Circuit Court for Sarasota County, Florida, Probate Division, the address of which is P.O. Box 3079, Sarasota, FL 34230. The names and addresses of the personal representative and the personal representative's attorney are set forth below.

All creditors of the decedent and other persons having claims or demands against decedent's estate, on whom a copy of this notice is required to be served must file their claims with this court ON OR BEFORE THE LATER OF 3 MONTHS AFTER THE TIME OF THE FIRST PUBLICATION OF THIS NOTICE OR 30 DAYS AFTER THE DATE OF SERVICE OF A COPY OF THIS NOTICE ON THEM.

All other creditors of the decedent and other persons having claims or demands against decedent's estate must file their claims with this court WITHIN 3 MONTHS AFTER THE DATE OF THE FIRST PUBLICATION OF THIS NOTICE.

ALL CLAIMS NOT FILED WITHIN THE TIME PERIODS SET FORTH IN SECTION 733.702 OF THE FLORIDA PROBATE CODE WILL BE FOREVER BARRED.

NOTWITHSTANDING THE TIME PERIOD SET FORTH ABOVE, ANY CLAIM FILED TWO (2) YEARS OR MORE AFTER THE DECEDENT'S DATE OF DEATH IS BARRED.

The date of first publication of this notice is: May 16, 2014.

MARILYN J. FILO
Personal Representative
443 Tremingham Way
Venice, FL 34293

H. Greg Lee
Attorney for Personal Representative
Email: hglee@hgreglee.com
Florida Bar No. 351301
H. GREG LEE, P.A.
2014 Fourth Street
Sarasota, Florida 34237
Telephone: (941) 954-0067
Facsimile: (941) 365-1492
May 16, 23, 2014 14-02173S

SECOND INSERTION

NOTICE TO CREDITORS
IN THE CIRCUIT COURT FOR
SARASOTA COUNTY, FLORIDA
PROBATE DIVISION
File No. 2014CP 001542 NC

IN RE: ESTATE OF
DORIS I. LONG
Deceased.

The administration of the estate of DO-RIS I. LONG, deceased, whose date of death was March 10, 2014; File Number 2014CP 001542 NC, is pending in the Circuit Court for Sarasota County, Florida, Probate Division, the address of which is P.O. Box 3079, Sarasota, FL 34230. The names and addresses of the personal representative and the personal representative's attorney are set forth below.

All creditors of the decedent and other persons having claims or demands against decedent's estate, on whom a copy of this notice is required to be served must file their claims with this court ON OR BEFORE THE LATER OF 3 MONTHS AFTER THE TIME OF THE FIRST PUBLICATION OF THIS NOTICE OR 30 DAYS AFTER THE DATE OF SERVICE OF A COPY OF THIS NOTICE ON THEM.

All other creditors of the decedent and other persons having claims or demands against decedent's estate must file their claims with this court WITHIN 3 MONTHS AFTER THE DATE OF THE FIRST PUBLICATION OF THIS NOTICE.

ALL CLAIMS NOT FILED WITHIN THE TIME PERIODS SET FORTH IN SECTION 733.702 OF THE FLORIDA PROBATE CODE WILL BE FOREVER BARRED.

NOTWITHSTANDING THE TIME PERIOD SET FORTH ABOVE, ANY CLAIM FILED TWO (2) YEARS OR MORE AFTER THE DECEDENT'S DATE OF DEATH IS BARRED.

The date of first publication of this notice is: May 16, 2014.

EDWARD JONES TRUST
COMPANY
Personal Representative
By: /s/ Elizabeth Anderson
Elizabeth Anderson, as its
Trust Officer

12555 Manchester Road
St. Louis, MO 63126
H. Greg Lee
Attorney for Personal Representative
Email: hglee@hgreglee.com
Florida Bar No. 351301
H. GREG LEE, P.A.
2014 Fourth Street
Sarasota, Florida 34237
Telephone: (941) 954-0067
Facsimile: (941) 365-1492
May 16, 23, 2014 14-02174S

SECOND INSERTION

NOTICE TO CREDITORS
IN THE CIRCUIT COURT FOR
SARASOTA COUNTY, FLORIDA
PROBATE DIVISION
FILE NO. 2014CP1740NC

IN RE: ESTATE OF
LAURA P. THOMPSON
Deceased.

The administration of the estate of LAURA P. THOMPSON, deceased, whose date of death was April 11, 2014; File Number 2014CP1740 NC, is pending in the Circuit Court for Sarasota County, Florida, Probate Division, the address of which is P.O. Box 3079, Sarasota, FL 34230. The names and addresses of the personal representative and the personal representative's attorney are set forth below.

All creditors of the decedent and other persons having claims or demands against decedent's estate, on whom a copy of this notice is required to be served must file their claims with this court WITHIN THE LATER OF 3 MONTHS AFTER THE TIME OF THE FIRST PUBLICATION OF THIS NOTICE OR 30 DAYS AFTER THE DATE OF SERVICE OF A COPY OF THIS NOTICE ON THEM.

All other creditors of the decedent and other persons having claims or demands against decedent's estate must file their claims with this court WITHIN 3 MONTHS AFTER THE DATE OF THE FIRST PUBLICATION OF THIS NOTICE.

ALL CLAIMS NOT FILED WITHIN THE TIME PERIODS SET FORTH IN SECTION 733.702 OF THE FLORIDA PROBATE CODE WILL BE FOREVER BARRED.

NOTWITHSTANDING THE TIME PERIOD SET FORTH ABOVE, ANY CLAIM FILED TWO (2) YEARS OR MORE AFTER THE DECEDENT'S DATE OF DEATH IS BARRED.

The date of first publication of this notice is: MAY 16, 2014.

LAWRENCE LOUIS THOMPSON
Personal Representative
500 Ave De Lafayette
Monroe, MI 48162

H. Greg Lee
Attorney for Personal Representative
Email: hglee@hgreglee.com
Florida Bar No. 351301
H. GREG LEE, P.A.
2014 Fourth Street
Sarasota, Florida 34237
Telephone: (941) 954-0067
Facsimile: (941) 365-1492
May 16, 23, 2014 14-02136S

SECOND INSERTION

NOTICE TO CREDITORS
(Summary Administration)
IN THE CIRCUIT COURT FOR
SARASOTA COUNTY,
FLORIDA
PROBATE DIVISION
FILE NUMBER 2014 CP 1893 NC

IN RE: ESTATE OF
EVERETT L. HAYDEN,
Deceased.

TO ALL PERSONS HAVING CLAIMS
OR DEMANDS AGAINST THE
ABOVE ESTATE:

You are hereby notified that an Order of Summary Administration has been entered in the estate of EVERETT L. HAYDEN, deceased, File Number 2014 CP 1893 ; by the Circuit Court for Sarasota County, Florida, Probate Division, the address of which is Post Office Box 3079, Sarasota, FL 34230; that the decedent's date of death was April 17, 2014; that the total value of the estate is Thirty-Four Thousand and One Dollar and Seventy Cents (\$34,001.70) and that the names and addresses of those to whom it has been assigned by such order are:

Name	Address
Creditors:	None ascertained
Beneficiaries:	

NAME	ADDRESS
Crystal Eve Corbett	1814 Ingram Avenue, Sarasota, Florida 34232

ALL INTERESTED PERSONS ARE NOTIFIED THAT:

All creditors of the estate of the decedent and persons having claims or demands against the estate of the decedent other than those for whom provision for full payment was made in the Order of Summary Administration must file their claims with this court WITHIN THE TIME PERIODS SET FORTH IN SECTION 733.702 OF THE FLORIDA PROBATE CODE.

ALL CLAIMS AND DEMANDS NOT SO FILED WILL BE FOREVER BARRED.

NOTWITHSTANDING ANY OTHER APPLICABLE TIME PERIOD, ANY CLAIM FILED TWO (2) YEARS OR MORE AFTER THE DECEDENT'S DATE OF DEATH IS BARRED.

Person Giving Notice:
Crystal Eve Corbett, Petitioner
Attorney for Person Giving Notice:

Allan F. Baily, FL BAR # 0138241
Law Offices of Baily & Baily, P.A.
46 N. Washington Blvd., Suite 18
Sarasota, Florida 34236
(941) 364-9997
bailylaw@verizon.net
Attorney for Petitioner
May 16, 23, 2014 14-02206S

SECOND INSERTION

NOTICE TO CREDITORS
IN THE CIRCUIT COURT FOR
SARASOTA COUNTY, FLORIDA
PROBATE DIVISION
FILE NO. 2014 CP 1576 NC

Division Probate
IN RE: ESTATE OF
ROSEMARY W. LAUBACH,
Deceased.

The administration of the estate of Rosemary W. Laubach, deceased, whose date of death was March 17, 2014, is pending in the Circuit Court for Sarasota County, Florida, Probate Division, the address of which is 2000 Ringling Blvd., Sarasota, FL 34237. The names and addresses of the personal representative and the personal representative's attorney are set forth below.

All creditors of the decedent and other persons having claims or demands against decedent's estate on whom a copy of this notice is required to be served must file their claims with this court WITHIN THE LATER OF 3 MONTHS AFTER THE TIME OF THE FIRST PUBLICATION OF THIS NOTICE OR 30 DAYS AFTER THE DATE OF SERVICE OF A COPY OF THIS NOTICE ON THEM.

All other creditors of the decedent and other persons having claims or demands against decedent's estate must file their claims with this court WITHIN 3 MONTHS AFTER THE DATE OF THE FIRST PUBLICATION OF THIS NOTICE.

ALL CLAIMS NOT FILED WITHIN THE TIME PERIODS SET FORTH IN SECTION 733.702 OF THE FLORIDA PROBATE CODE WILL BE FOREVER BARRED.

NOTWITHSTANDING THE TIME PERIODS SET FORTH ABOVE, ANY CLAIM FILED TWO (2) YEARS OR MORE AFTER THE DECEDENT'S DATE OF DEATH IS BARRED.

The date of first publication of this notice is May 16, 2014.

Personal Representative:
Richard C. Blake
2433 Yorkshire Drive
Sarasota, Florida 34231
Attorney for Personal Representative:
John T. Griffin
Attorney

Florida Bar Number: 0674281
8482 S. Tamiami Trail
SARASOTA, FL 34238
Telephone: (941) 966-2700
Fax: (941) 966-2722
E-Mail: john@griffinelderlaw.com
Secondary E-Mail:
tish@griffinelderlaw.com
May 16, 23, 2014 14-02117S

SECOND INSERTION

NOTICE TO CREDITORS
IN THE CIRCUIT COURT FOR
SARASOTA COUNTY, FLORIDA
PROBATE DIVISION
File No. 2014-CP-001733 NC

Division Probate
IN RE: ESTATE OF
LEIGH JOHNSON KEMNITZ
Deceased.

The administration of the estate of LEIGH JOHNSON KEMNITZ, deceased, whose date of death was April 19, 2014, is pending in the Circuit Court for SARASOTA County, Florida, Probate Division, the address of which is 2000 Main Street, Sarasota, FL 34236. The names and addresses of the personal representative and the personal representative's attorney are set forth below.

All creditors of the decedent and other persons having claims or demands against decedent's estate on whom a copy of this notice is required to be served must file their claims with this court WITHIN THE LATER OF 3 MONTHS AFTER THE TIME OF THE FIRST PUBLICATION OF THIS NOTICE OR 30 DAYS AFTER THE DATE OF SERVICE OF A COPY OF THIS NOTICE ON THEM.

All other creditors of the decedent and other persons having claims or demands against decedent's estate must file their claims with this court WITHIN 3 MONTHS AFTER THE DATE OF THE FIRST PUBLICATION OF THIS NOTICE.

ALL CLAIMS NOT FILED WITHIN THE TIME PERIODS SET FORTH IN SECTION 733.702 OF THE FLORIDA PROBATE CODE WILL BE FOREVER BARRED.

NOTWITHSTANDING THE TIME PERIODS SET FORTH ABOVE, ANY CLAIM FILED TWO (2) YEARS OR MORE AFTER THE DECEDENT'S DATE OF DEATH IS BARRED.

The date of first publication of this notice is MAY 16, 2014.

Personal Representative:
Jane Leigh Johnson
2028 Lexington Avenue
San Mateo, California 94402

Attorney for Personal Representative:
F. Gant McCloud
Attorney for Personal Representative
Florida Bar Number: 0072163
KIRK-PINKERTON, P.A.
PO Box 3798
Sarasota, FL 34230
Telephone: (941) 364-2400
Fax: (941) 364-2490
E-Mail: gmcloud@kirkpinkerton.com
Secondary E-Mail:
socd@kirkpinkerton.com
May 16, 23, 2014 14-02135S

SECOND INSERTION

NOTICE TO CREDITORS
IN THE CIRCUIT COURT FOR
SARASOTA COUNTY, FLORIDA
PROBATE DIVISION
FILE NO.: 2013 CP 004597 NC

IN RE: ESTATE OF
PATRICIA A. DAVIS-SEELBACH,
a/k/a PATRICIA A. DAVIS,
Deceased.

The administration of the estate of PATRICIA A. DAVIS-SEELBACH a/k/a PATRICIA A. DAVIS, deceased, whose date of death was March 7, 2013, is pending in the Circuit Court for Sarasota County, Florida, Probate Division, the address of which is 2000 Main Street, Sarasota, FL 34237. The names and addresses of the personal representative and the personal representative's attorney are set forth below.

All creditors of the decedent and other persons having claims or demands against decedent's estate on whom a copy of this notice is required to be served must file their claims with this court WITHIN THE LATER OF 3 MONTHS AFTER THE TIME OF THE FIRST PUBLICATION OF THIS NOTICE OR 30 DAYS AFTER THE DATE OF SERVICE OF A COPY OF THIS NOTICE ON THEM.

All other creditors of the decedent and other persons having claims or demands against decedent's estate must file their claims with this court WITHIN 3 MONTHS AFTER THE DATE OF THE FIRST PUBLICATION OF THIS NOTICE.

ALL CLAIMS NOT FILED WITHIN THE TIME PERIODS SET FORTH IN SECTION 733.702 OF THE FLORIDA PROBATE CODE WILL BE FOREVER BARRED.

NOTWITHSTANDING THE TIME PERIODS SET FORTH ABOVE, ANY CLAIM FILED TWO (2) YEARS OR MORE AFTER THE DECEDENT'S DATE OF DEATH IS BARRED.

The date of first publication of this notice is May 16, 2014.

Personal Representative:
JESSIE HASH
230 Robin Hood Trail
San Angelo, Texas 76901
Attorney for Personal Representative:
ABRAMS BERGER, P.A.
TERRY ABRAMS BERGER, ESQ.
Attorney for JESSIE HASH

Florida Bar Number: 046000
3860A Sheridan Street
Hollywood, Florida 33021
Telephone: (954) 921-4489
Facsimile: (954) 335-0955
E-Mail: abodden@abramsberger.com
Secondary E-Mail:
abodden@abramsberger.com
May 16, 23, 2014 14-02134S

SECOND INSERTION

NOTICE TO CREDITORS
IN THE CIRCUIT COURT FOR
SARASOTA COUNTY, FLORIDA
PROBATE DIVISION
File No. 2014CP001745SC

Division PROBATE
IN RE: ESTATE OF
LYNDA H. HOLMES
Deceased.

The administration of the estate of Lynda H. Holmes, deceased, whose date of death was July 13, 2013, is pending in the Circuit Court for Sarasota County, Florida, Probate Division, the address of which is Post Office Box 3079, Sarasota, Florida 34230-3079. The names and addresses of the personal representative and the personal representative's attorney are set forth below.

All creditors of the decedent and other persons having claims or demands against decedent's estate on whom a copy of this notice is required to be served must file their claims with this court WITHIN THE LATER OF 3 MONTHS AFTER THE TIME OF THE FIRST PUBLICATION OF THIS NOTICE OR 30 DAYS AFTER THE DATE OF SERVICE OF A COPY OF THIS NOTICE ON THEM.

All other creditors of the decedent and other persons having claims or demands against decedent's estate must file their claims with this court WITHIN 3 MONTHS AFTER THE DATE OF THE FIRST PUBLICATION OF THIS NOTICE.

ALL CLAIMS NOT FILED WITHIN THE TIME PERIODS SET FORTH IN SECTION 733.702 OF THE FLORIDA PROBATE CODE WILL BE FOREVER BARRED.

NOTWITHSTANDING THE TIME PERIODS SET FORTH ABOVE, ANY CLAIM FILED TWO (2) YEARS OR MORE AFTER THE DECEDENT'S DATE OF DEATH IS BARRED.

The date of first publication of this notice is May 16, 2014.

Personal Representative:
Craig L. Holmes
1141 Ironwood Dr.
Findlay, Ohio 45840

Attorney for Personal Representative:
Cord C. Mellor
Attorney
Florida Bar Number: 0201235
MELLOR & GRISSINGER
13801-D South Tamiami Trail
North Port, FL 34287
Telephone: (941) 426-1193
Fax: (941) 426-5413
E-Mail: cord@northportlaw.com
May 16, 23, 2014 14-02137S

SECOND INSERTION

NOTICE TO CREDITORS
IN THE CIRCUIT COURT FOR
SARASOTA COUNTY, FLORIDA
PROBATE DIVISION
FILE NO. 2014-CP-001859-NC

IN RE: ESTATE OF
MARGARET SOOS SLABY
A/K/A MARGARET SLABY
Deceased

The administration of the estate of MARGARET SOOS SLABY A/K/A MARGARET SLABY, deceased, whose date of death was APRIL 27, 2014, and the last four digits of whose Social Security number is 0725, is pending in the Circuit Court for SARASOTA County, Florida, Probate Division, the address of which is P.O. BOX 3079, SARASOTA, FL 34230. The names and addresses of the Personal Representative and the Personal Representative's attorney are set forth below.

All creditors of the decedent and other persons having claims or demands against decedent's estate, on whom a copy of this notice is required to be served must file their claims with this Court WITHIN THE LATER OF 3 MONTHS AFTER THE DATE OF THE FIRST PUBLICATION OF THIS NOTICE OR 30 DAYS AFTER THE DATE OF SERVICE OF A COPY OF THIS NOTICE ON THEM.

All other creditors of the decedent and other persons having claims or demands against decedent's estate, must file their claims with this Court WITHIN 3 MONTHS AFTER THE DATE OF THE FIRST PUBLICATION OF THIS NOTICE.

ALL CLAIMS NOT SO FILED WITHIN THE TIME PERIODS SET FORTH IN SECTION 733.702 OF THE FLORIDA PROBATE CODE WILL BE FOREVER BARRED.

NOTWITHSTANDING THE TIME PERIODS SET FORTH ABOVE, ANY CLAIM FILED TWO (2) YEARS OR MORE AFTER THE DECEDENT'S DATE OF DEATH IS BARRED.

The date of first publication of this Notice is May 16, 2014.

Personal Representative:
JOSEPH SLABY
C/O THEODORE A.
GOLLNICK, ESQ.
100 WALLACE AVE., STE. 205
SARASOTA, FL 34237
(941) 365-9195

Attorney for Personal Representative:
THEODORE A. GOLLNICK, P.A.
THEODORE A. GOLLNICK, ESQ.
FLORIDA BAR NO. 31071

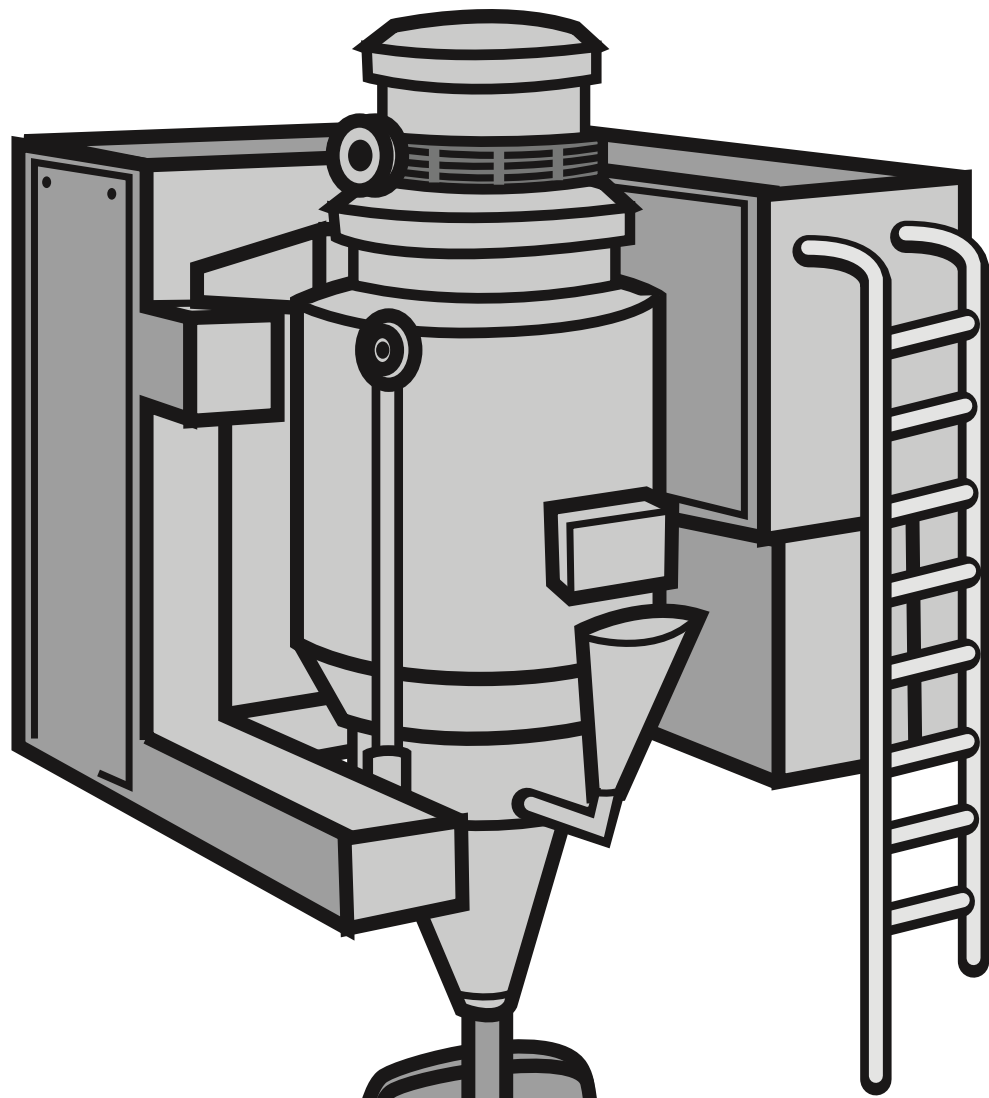

A special printing of
a classic story illustrating
the importance of
protecting capitalism.

TOM SMITH AND HIS INCREDIBLE BREAD MACHINE

By **R.W. Grant**

Illustrations by Austin McKinley

This is the legend of a man whose name
Was a household word: a man whose fame
Burst on the world like an atom bomb.
Smith was his last name; first name: Tom.

The argument goes on today.
"He was a villain," some will say.
"No! A hero!" others declare.
Or was he both? Well, I despair;
The fight will last 'til kingdom come;
Was Smith a hero? Or was Smith a bum?
So, listen to the story and it's up to you
To decide for yourself as to which is true!

Now, Smith, an inventor, had specialized
In toys. So people were surprised
When they found that he instead
Of making toys, was baking bread!
The news was flashed by CBS
Of his incredible success.
Then NBC jumped in in force,
Followed by the Times, of course.
The reason for their rapt attention,
The nature of his new invention,
The way to make bread he'd conceived
Cost less than people could believe!
And not just make it! This device
Could in addition wrap and slice!
The price per loaf, one loaf or many:
The miniscule sum of under one penny!

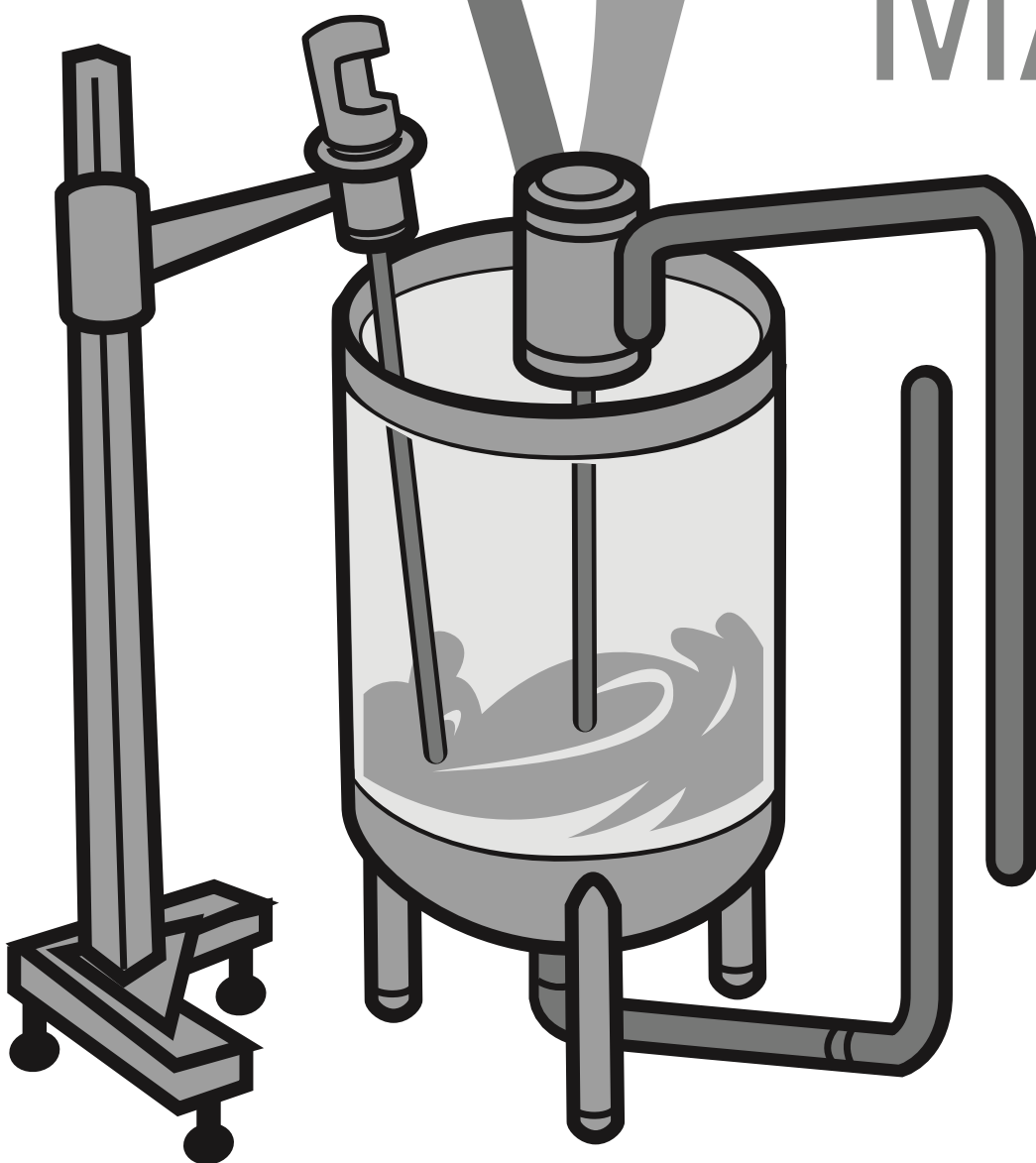

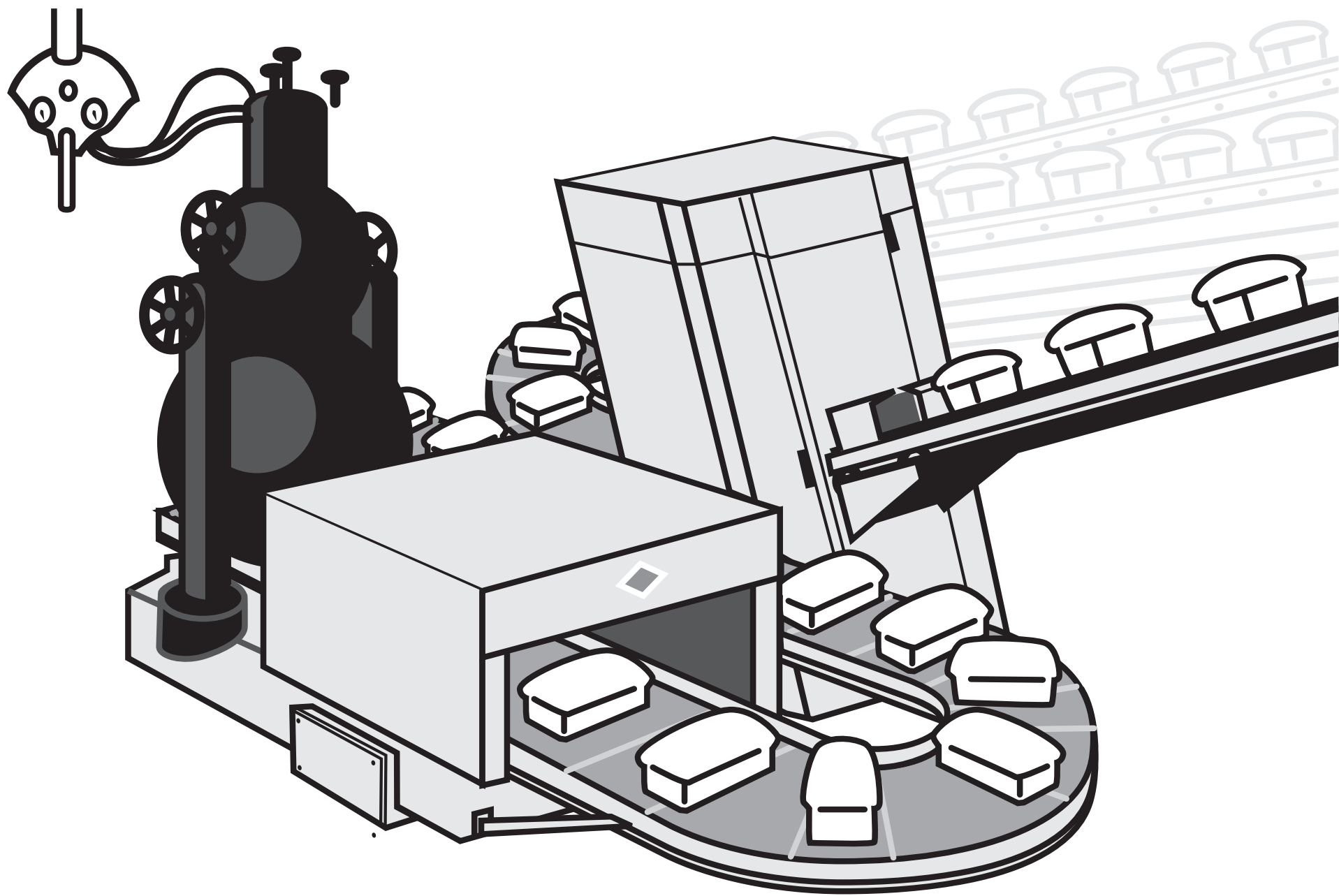

Can you imagine what this meant?
Can you comprehend the consequent?
The first time yet the world well fed!
And all because of Tom Smith's bread!

Not the last to see the repercussions
Were the Red Chinese, and, of course, the
Russians,
For Capitalist bread in such array

Threw the whole red block into black dis-
may!
Nonetheless, the world soon found
That bread was plentiful the world
around.
Thanks to Smith and all that bread,
A grateful world was at last well fed!

But isn't it a wondrous thing
How quickly fame is flown?
Smith, the hero of today
Tomorrow, scarcely known!
Yes, the fickle years passed by.
Smith was a billionaire.

But Smith himself was now forgot,
Though bread was everywhere.
People, asked from where it came,
Would very seldom know.

They would simply eat and ask,
'Was not it always so?'

However, Smith cared not a bit,
For millions ate his bread,
And "Everything is fine," thought he.
'I'm rich and they are fed!'

Everything was fine, he thought?
He reckoned not with fate.
Note the sequence of events
Starting on the date
On which inflation took its toll,
And to a slight extent,
The price on every loaf increased:
It went to one full cent!

A sharp reaction quickly came.
People were concerned.
White House aide expressed dismay.
Then the nation learned
That Russia lodged a sharp protest.
India did the same.
"Exploitation of the Poor!"
Yet, who was there to blame?

And though the clamor ebbed and flowed,
All that Tom would say
Was that it was but foolish talk.
Which soon would die away.
And it appeared that he was right.
Though on and on it ran,
The argument went 'round and 'round
But stopped where it began.

There it stopped, and people cried,
"For heaven's sake, we can't decide!
It's relative! Beyond dispute,
There's no such thing as 'absolute'!
And though we try with all our might,
Since nothing's ever black or white,
All that we can finally say is
'Everything one shade of grey is!'
So people cried out, "Give us light!
We can't tell what's wrong from right!"

To comprehend confusion,
We seek wisdom at its source.
To whom, then did the people turn?
The Intellectuals, of course!

And what could be a better time
For them to take the lead,
Than at their International Conference
On Inhumanity and Greed.
For at this weighty conference,
Once each year we face
The moral conscience of the world—
Concentrated in one place.

At that mighty conference were
A thousand, more or less,
Of intellectuals and bureaucrats,
And those who write the press.
And from Yale and Harvard
The professors; all aware
The fate of Smith would now be known.
Excitement filled the air!

"The time has come," the chairman said
"To speak of many things:
Of duty, bread and selfishness,
And the evil that it brings.
For, speaking thus we can amend
That irony of fate
That gives to unenlightened minds
The power to create.



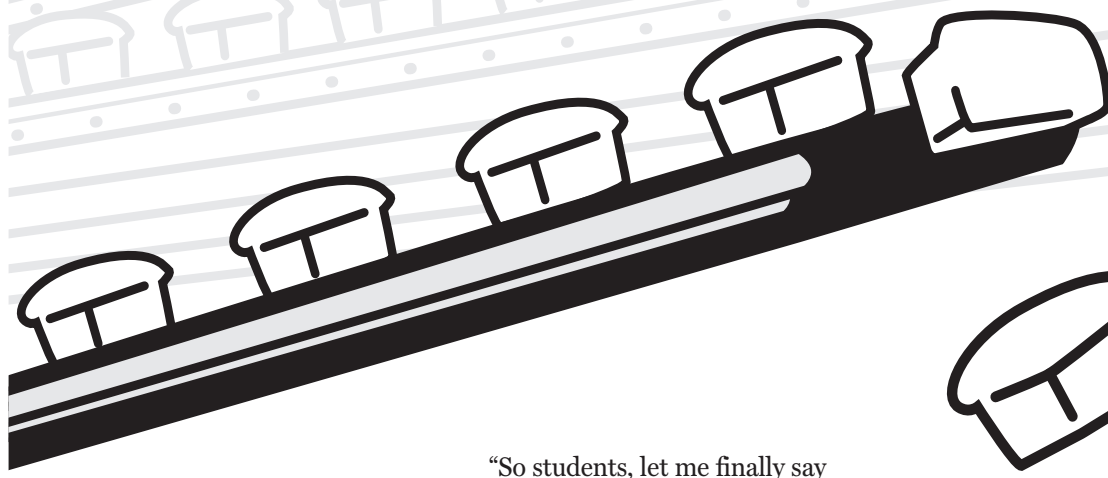

“Since reason tells us that it can’t,
Therefore let us start
Not by thinking with the mind,
But only with the heart!
Since we believe in people, then,”
At last the chairman said,
“We must meet our obligation
To see that they are fed!”

And so it went, one by one,
Denouncing private greed;
Denouncing those who’d profit thus
From other people’s need!

Then, suddenly each breath was held,
For there was none more wise
Than the nation’s foremost Pundit
Who now rose to summarize:

“My friends,” he said, (they all
exhaled)
“We see in these events
The flouting of the Higher Law—
And its consequence.
We must again remind ourselves
Just why mankind is cursed:
Because we fail to realize
Society comes first!”

“Smith placed himself above the
group
To profit from his brothers.
He failed to see the Greater Good,
Is Service, friends, to Others!”

With boldness and with vision,
then,
They ratified the motion
To dedicate to all mankind
Smith’s bread—and their devotion!

The conference finally ended.
It had been a huge success.
The intellectuals had spoken.
Now others did the rest.

The professors joined in all the
fuss,
And one was heard to lecture thus:
(For clarity, he spoke in terms
Of Mother Nature, birds and worms):

“That early birds should get the worm
Is clearly quite unfair.
Wouldn’t it much nicer be
If all of them would share?
But selfishness and private greed

Seem part of nature’s plan,
Which Mother Nature has decreed
For bird. But also Man?
The system which I question now,
As you are well aware,
(I’m sure you’ve heard the term
before
Is Business, Laissez-Faire!

“So students, let me finally say
That we must find a nobler way.
So, let us fix the race that all
May finish side-by-side;
The playing field forever flat,
The score forever tied.
To achieve this end, of course,
We turn to government—and force.
So, if we have to bring Smith do
As indeed we should,
I’m sure you will agree with me,
It’s for the Greater Good!”

Comments in the nation’s press
Now scorned Smith and his plunder:
“What right had he to get so rich
On other people’s hunger?”
A prize cartoon depicted Smith
With fat and drooping jowls
Snatching bread from hungry babes,
Indifferent to their howls.

One night, a TV star cried out,
“Forgive me if I stumble,
But I don’t think, I kid you not,
That Smith is very humble!”
Growing bolder, he leaped up,

(Silencing the cheers)
“Humility!” he cried to all—
And then collapsed in tears!

The clamor rises all about;
Now hear the politician shout:
“What’s Smith done, so rich to be?
Why should Smith have more than thee?
So, down with Smith and all his greed;
I’ll protect your right to need!”

Then Tom found to his dismay
That certain businessmen would say,
“The people now should realize
It’s time to cut Smith down to size,
For he’s betrayed his public trust
(And taken all that bread from us!)”

Well, since the Public does come first,
It could not be denied
That in matters such as this,
The public must decide.
So, SEC became concerned,
And told the press what it had learned:
“It’s obvious that he’s guilty
—Of what we’re not aware—
Though actually and factually
We’re sure there’s something there!”

And Antitrust now took a hand.
Of course it was appalled
At what it found was going on.
The “bread trust” it was called.

“Smith has too much crust,”
they said. “A deplorable condition
That Robber Barons profit thus
From cutthroat competition!”

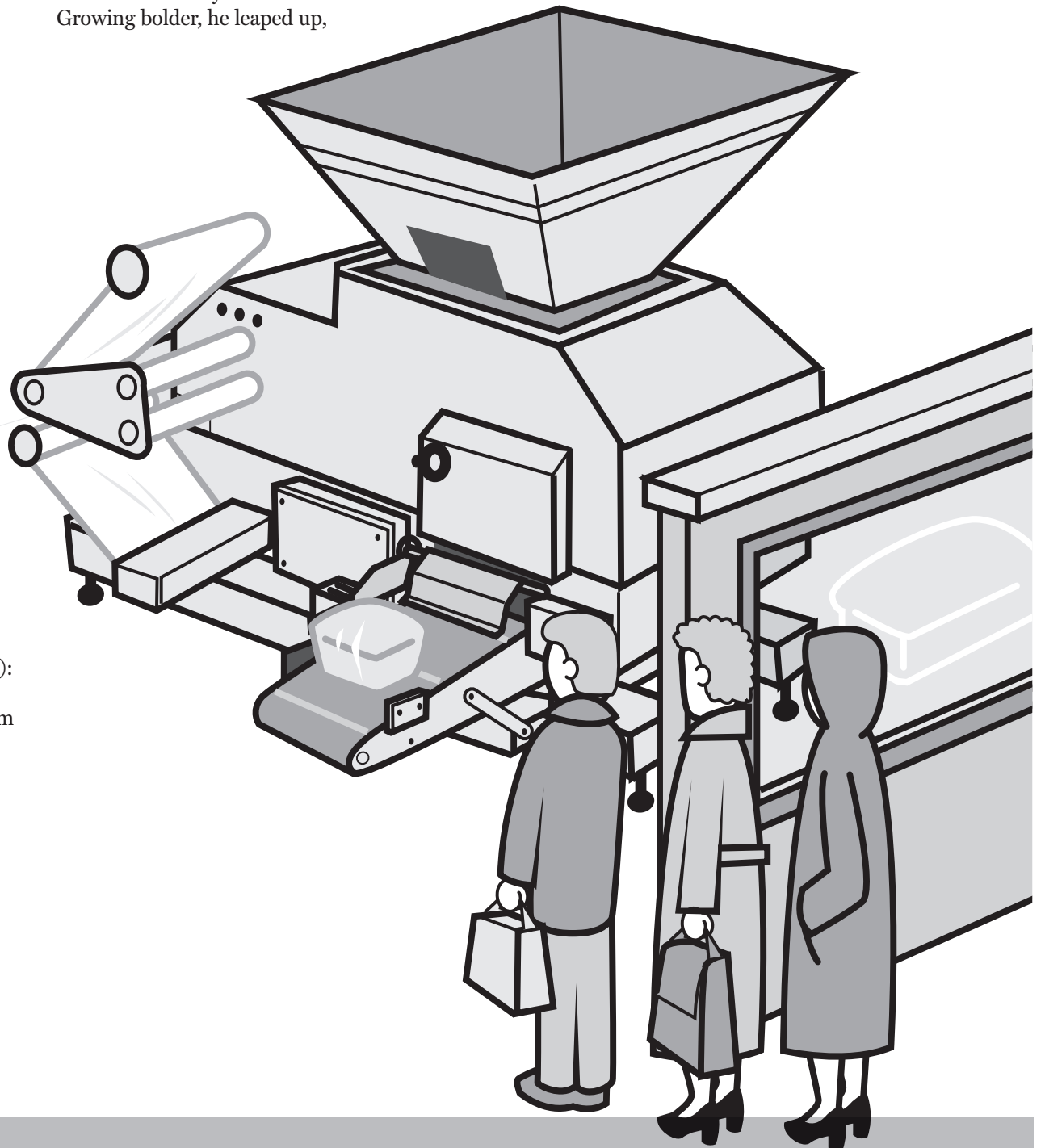

WELL!

This was getting serious!
So Smith felt that he must
Have a friendly interview
With SEC and 'Trust.
So, hat in hand, he went to them.
They'd surely been misled;
No rule of law had he defied.
But then their lawyer said:

"The rule of law, in complex times,
Has proved itself deficient.
We much prefer the rule of men.
It's vastly more efficient.

"So, nutshell-wise, the way it is,
The law is what we say it is!

"So, let me state the present rules,"
The lawyer then went on,
"These very simple guidelines
You can rely upon:
You're gouging on your prices
If you charge more than the rest.
But it's unfair competition
If you think you can charge less!
"A second point that we would make,
To help avoid confusion:
Don't try to charge the same amount,
For that would be collusion!

"You must compete—but not too much.
For if you do, you see,
Then the market would be yours—
And that's monopoly!
Oh, don't dare monopolize!
We'd raise an awful fuss,
For that's the greatest crime of all!
(Unless it's done by us!)"

"I think I understand," said Tom.
"And yet, before I go,
How does one get a job like yours?
I'd really like to know!"

The lawyer rose then with a smile;
"I'm glad you asked," said he.
"I'll tell you how I got my start
And how it came to be."

(His secretaries gathered 'round
As their boss did thus expound.)

*"When I was a lad going off to school,
I was always guided by this golden rule:
Let others take the lead in things, for
heaven's sake,
So if things go wrong-why, then it's their
mistake!"*
(*So if things go wrong-why, then it's their
mistake!*)

*"Following this precept it came to pass
I became the president of my senior class.
Then on to college where my profs extolled
The very same theory from the very same
mold!"*
(*The very same theory from the very same
mold!*)

*"Let others take the chances, and I would
go along.
Then I would let them know where they all
went wrong!
So successful was my system that then
indeed,
I was voted most likely in my class to suc-
ceed!"*

*(He was voted most likely in his class to
succeed!)*

*"Then out into the world I went, along
with all the rest,
Where I put my golden rule to the ulti-
mate test.
I avoided all of commerce at whatever the
cost—
And because I never ventured, then I also
never lost!"*
(*And because he never ventured, then he
also never lost!*)

*"With this unblemished record then, I
quickly caught the eye
Of some influential people 'mongst the
powers on high.*

*And so these many years among the
mighty I have sat,
Having found my niche as a bureaucrat!"*
(*Having found his niche as a bureaucrat*)

*"To be a merchant prince has never been
my goal,
For I'm qualified to play a more impor-
tant role:
Since I've never failed in business, this of
course assures
That I'm qualified beyond dispute to now
run yours!"*
(*That he's qualified beyond dispute to now
run yours!*)

"Thanks; that clears it up," said Tom.

The lawyer said, "I'm glad!
We try to serve the public good.
We're really not so bad!"

"Now, in disposing of this case,
If you wish to know just how,
Go up to the seventh floor;
We're finalizing now!"

So, Tom went to the conference room
Up on the seventh floor.
He raised his hand, about to knock,
He raised it—but no more—
For what he overheard within
Kept him outside the door!
A sentence here, a sentence there—
Every other word—
He couldn't make it out (he hoped),
For this is what he heard:

"Mumble, mumble, let's not fumble!
Mumble, mumble, what's the charge?
Grumble, grumble, he's not humble?
Private greed? Or good of all?"

"Public Interest, Rah! Rah! Rah!
Business, Business, Bah! Bah! Bah!"

"Say, now this now we confess
That now this now is a mess!
Well now, what now do we guess?
Discharge? Which charge would be best?"

"How 'bout 'Greed and Selfishness'?
Oh, wouldn't that be fun?
It's vague enough to trip him up
No matter what he's done!"

"We don't produce or build a thing!
But before we're through,
We allow that now we'll show Smith how
We handle those who do!"

"We serve the public interest;
We make up our own laws;
Oh, golly gee, how selflessly
We serve the public cause!"

"For we're the ones who make the rules
At 'Trust and SEC,
So bye and bye we'll get that guy;
Now, what charge will it be?"

"Price too high? Or price too low?
Now, which charge will we make?
Well, we're not loath to charging both
When public good's at stake!"

"But can we go one better?
How 'bout monopoly?
No muss, no fuss, oh clever us!
Right-O! Let's charge all three!"

"But why stop here? We have one more!
Insider Trading! Number four!
We've not troubled to define
This crime in any way so,
This allows the courts to find
Him guilty 'cause we say so!"

So, that was the indictment.
Smith's trial soon began.
It was a cause célèbre
Which was followed' cross the land.
In his defense Tom only said,
"I'm rich, but all of you are fed!
Is that bargain so unjust
That I should now be punished thus?"

Tom fought it hard all the way.
But it didn't help him win.
The jury took but half an hour
To bring this verdict in:

"Guilty! Guilty! We agree!
He's guilty of this plunder!
He had no right to get so rich
On other people's hunger!"

"Five years in jail!" the judge then said.
"You're lucky it's not worse!
Robber Barons must be taught
Society Comes First!
As flies to wanton boys," he leered,
"Are we to men like these!
They exploit us for their sport!
Exploit us as they please!"

The sentence seemed a bit severe,
But mercy was extended.
In deference to his mother's pleas,
One year was suspended.
And what about the Bread Machine?
Tom Smith's little friend?
Broken up and sold for scrap.
Some win. Some lose. The end.

EPILOGUE

Now, bread is baked by government.
And as might be expected,
Everything is well controlled—
The public well protected.

True, loaves cost ten dollars each.
But our leaders do their best.
The selling price is half a cent.
Taxes pay the rest!

