

FIRST INSERTION

NOTICE OF APPLICATION FOR TAX DEED

Notice is hereby given that FL COMM BANK CLTRL ASGNE OF MAGNOLIA TC 4 TDA, LLC, the holder of the certificate listed below, has filed said certificate for a tax deed to be issued. The certificate number and year of issuance, the description of the property, and the names in which the property is assessed are as follows:

Certificate Number: 11376.000
Year of Issuance: 2012
Tax Deed File #: 14-0101 TD

Description of Property: 2021022042 UNIT 371D GLEN OAKS GARDEN APTS SEC 2
Name in which the property is assessed: IRENE EDGE 1/2 INT & LINDA JOHANNING & ANTHONY JOHANNING 1/2 INT
All of said property being in the County of Sarasota, State of Florida. Unless the certificate is redeemed according to law, the property described in the certificate will be sold to the highest bidder at the Sarasota County Court House, 2000 Main Street, Historic Courtroom, East Wing, Sarasota, Florida, at 9:00 a.m. on the 1ST day of JULY, 2014.

Karen E. Rushing
Clerk Of The Circuit Court
Sarasota County, Florida
By: T. Lake, Deputy Clerk
Publication Dates: MAY 30; JUNE 6, 13, 20 2014

14-02482S

FIRST INSERTION

NOTICE OF APPLICATION FOR TAX DEED

Notice is hereby given that FL COMM BANK CLTRL ASGNE OF MAGNOLIA TC 4 TDA, LLC, the holder of the certificate listed below, has filed said certificate for a tax deed to be issued. The certificate number and year of issuance, the description of the property, and the names in which the property is assessed are as follows:

Certificate Number: 3191.000
Year of Issuance: 2012
Tax Deed File #: 14-0090 TD

Description of Property: 0451010015 LOTS 11069 & 11070 SOUTH VENICE UNIT 42
Name in which the property is assessed: NATHAN B TRACY II
All of said property being in the County of Sarasota, State of Florida. Unless the certificate is redeemed according to law, the property described in the certificate will be sold to the highest bidder at the Sarasota County Court House, 2000 Main Street, Historic Courtroom, East Wing, Sarasota, Florida, at 9:00 a.m. on the 1ST day of JULY, 2014.

Karen E. Rushing
Clerk Of The Circuit Court
Sarasota County, Florida
By: T. Lake, Deputy Clerk
Publication Dates: MAY 30; JUNE 6, 13, 20 2014

14-02473S

FIRST INSERTION

NOTICE OF APPLICATION FOR TAX DEED

Notice is hereby given that PURIS ENVIRONMENTAL INC TRENCH-FIELD KIRK, the holder of the certificate listed below, has filed said certificate for a tax deed to be issued. The certificate number and year of issuance, the description of the property, and the names in which the property is assessed are as follows:

Certificate Number: 10033.000
Year of Issuance: 2012
Tax Deed File #: 14-0110 TD

Description of Property: 1140176614 LOT 14 BLK 1766 34TH ADD TO PORT CHARLOTTE
Name in which the property is assessed: LAZARO D RODRIGUEZ
All of said property being in the County of Sarasota, State of Florida. Unless the certificate is redeemed according to law, the property described in the certificate will be sold to the highest bidder at the Sarasota County Court House, 2000 Main Street, Historic Courtroom, East Wing, Sarasota, Florida, at 9:00 a.m. on the 1ST day of JULY, 2014.

Karen E. Rushing
Clerk Of The Circuit Court
Sarasota County, Florida
By: T. Lake, Deputy Clerk
Publication Dates: MAY 30; JUNE 6, 13, 20 2014

14-02484S

FIRST INSERTION

NOTICE OF APPLICATION FOR TAX DEED

Notice is hereby given that FL COMM BANK CLTRL ASGNE OF MAGNOLIA TC 4 TDA, LLC, the holder of the certificate listed below, has filed said certificate for a tax deed to be issued. The certificate number and year of issuance, the description of the property, and the names in which the property is assessed are as follows:

Certificate Number: 7464.000
Year of Issuance: 2012
Tax Deed File #: 14-0094 TD

Description of Property: 0995261314 LOT 14 BLK 2613 52ND ADD TO PORT CHARLOTTE
Name in which the property is assessed: CATHERINE D HUFFMAN & ROBERT M HUFFMAN
All of said property being in the County of Sarasota, State of Florida. Unless the certificate is redeemed according to law, the property described in the certificate will be sold to the highest bidder at the Sarasota County Court House, 2000 Main Street, Historic Courtroom, East Wing, Sarasota, Florida, at 9:00 a.m. on the 1ST day of JULY, 2014.

Karen E. Rushing
Clerk Of The Circuit Court
Sarasota County, Florida
By: T. Lake, Deputy Clerk
Publication Dates: MAY 30; JUNE 6, 13, 20 2014

14-02477S

FIRST INSERTION

NOTICE OF APPLICATION FOR TAX DEED

Notice is hereby given that PURIS ENVIRONMENTAL INC TRENCH-FIELD KIRK, the holder of the certificate listed below, has filed said certificate for a tax deed to be issued. The certificate number and year of issuance, the description of the property, and the names in which the property is assessed are as follows:

Certificate Number: 8973.000
Year of Issuance: 2012
Tax Deed File #: 14-0109 TD

Description of Property: 1128227322 TRACT P CONTAINING 1.61 AC M/L 47TH ADD TO PORT CHARLOTTE
Name in which the property is assessed: TARPON IV LLC
All of said property being in the County of Sarasota, State of Florida. Unless the certificate is redeemed according to law, the property described in the certificate will be sold to the highest bidder at the Sarasota County Court House, 2000 Main Street, Historic Courtroom, East Wing, Sarasota, Florida, at 9:00 a.m. on the 1ST day of JULY, 2014.

Karen E. Rushing
Clerk Of The Circuit Court
Sarasota County, Florida
By: T. Lake, Deputy Clerk
Publication Dates: MAY 30; JUNE 6, 13, 20 2014

14-02483S

FIRST INSERTION

NOTICE OF APPLICATION FOR TAX DEED

Notice is hereby given that FL COMM BANK CLTRL ASGNE OF MAGNOLIA TC 4 TDA, LLC, the holder of the certificate listed below, has filed said certificate for a tax deed to be issued. The certificate number and year of issuance, the description of the property, and the names in which the property is assessed are as follows:

Certificate Number: 7596.000
Year of Issuance: 2012
Tax Deed File #: 14-0095 TD

Description of Property: 0998248110 LOT 10 BLK 2481 50TH ADD TO PORT CHARLOTTE
Name in which the property is assessed: SHENA M KENDRICK & JEREMIE L KENDRICK
All of said property being in the County of Sarasota, State of Florida. Unless the certificate is redeemed according to law, the property described in the certificate will be sold to the highest bidder at the Sarasota County Court House, 2000 Main Street, Historic Courtroom, East Wing, Sarasota, Florida, at 9:00 a.m. on the 1ST day of JULY, 2014.

Karen E. Rushing
Clerk Of The Circuit Court
Sarasota County, Florida
By: T. Lake, Deputy Clerk
Publication Dates: MAY 30; JUNE 6, 13, 20 2014

14-02478S

FIRST INSERTION

NOTICE OF APPLICATION FOR TAX DEED

Notice is hereby given that FL COMM BANK CLTRL ASGNE OF MAGNOLIA TC 4 TDA, LLC, the holder of the certificate listed below, has filed said certificate for a tax deed to be issued. The certificate number and year of issuance, the description of the property, and the names in which the property is assessed are as follows:

Certificate Number: 11298.000
Year of Issuance: 2012
Tax Deed File #: 14-0100 TD

Description of Property: 2020090036 LOT 17 BLK B NEWTOWN HEIGHTS
Name in which the property is assessed: ERVIN HODGES
All of said property being in the County of Sarasota, State of Florida. Unless the certificate is redeemed according to law, the property described in the certificate will be sold to the highest bidder at the Sarasota County Court House, 2000 Main Street, Historic Courtroom, East Wing, Sarasota, Florida, at 9:00 a.m. on the 1ST day of JULY, 2014.

Karen E. Rushing
Clerk Of The Circuit Court
Sarasota County, Florida
By: T. Lake, Deputy Clerk
Publication Dates: MAY 30; JUNE 6, 13, 20 2014

14-02481S

FIRST INSERTION

NOTICE OF APPLICATION FOR TAX DEED

Notice is hereby given that FL COMM BANK CLTRL ASGNE OF MAGNOLIA TC 4 TDA, LLC, the holder of the certificate listed below, has filed said certificate for a tax deed to be issued. The certificate number and year of issuance, the description of the property, and the names in which the property is assessed are as follows:

Certificate Number: 7451.000
Year of Issuance: 2012
Tax Deed File #: 14-0093 TD

Description of Property: 0995193722 LOT 22 BLK 1937 41ST ADD TO PORT CHARLOTTE
Name in which the property is assessed: LEROY KUECKER
All of said property being in the County of Sarasota, State of Florida. Unless the certificate is redeemed according to law, the property described in the certificate will be sold to the highest bidder at the Sarasota County Court House, 2000 Main Street, Historic Courtroom, East Wing, Sarasota, Florida, at 9:00 a.m. on the 1ST day of JULY, 2014.

Karen E. Rushing
Clerk Of The Circuit Court
Sarasota County, Florida
By: T. Lake, Deputy Clerk
Publication Dates: MAY 30; JUNE 6, 13, 20 2014

14-02476S

FIRST INSERTION

NOTICE OF APPLICATION FOR TAX DEED

Notice is hereby given that FL COMM BANK CLTRL ASGNE OF MAGNOLIA TC 4 TDA, LLC, the holder of the certificate listed below, has filed said certificate for a tax deed to be issued. The certificate number and year of issuance, the description of the property, and the names in which the property is assessed are as follows:

Certificate Number: 7606.000
Year of Issuance: 2012
Tax Deed File #: 14-0096 TD

Description of Property: 0998251202 LOT 2 BLK 2512 50TH ADD TO PORT CHARLOTTE
Name in which the property is assessed: CAROL A JEFFERSON
All of said property being in the County of Sarasota, State of Florida. Unless the certificate is redeemed according to law, the property described in the certificate will be sold to the highest bidder at the Sarasota County Court House, 2000 Main Street, Historic Courtroom, East Wing, Sarasota, Florida, at 9:00 a.m. on the 1ST day of JULY, 2014.

Karen E. Rushing
Clerk Of The Circuit Court
Sarasota County, Florida
By: T. Lake, Deputy Clerk
Publication Dates: MAY 30; JUNE 6, 13, 20 2014

14-02479S

FIRST INSERTION

NOTICE OF APPLICATION FOR TAX DEED

Notice is hereby given that FL COMM BANK CLTRL ASGNE OF MAGNOLIA TC 4 TDA, LLC, the holder of the certificate listed below, has filed said certificate for a tax deed to be issued. The certificate number and year of issuance, the description of the property, and the names in which the property is assessed are as follows:

Certificate Number: 7671.000
Year of Issuance: 2012
Tax Deed File #: 14-0098 TD

Description of Property: 1001184911 LOT 11 BLK 1849 40TH ADD TO PORT CHARLOTTE
Name in which the property is assessed: RONALD P MARRA EST
All of said property being in the County of Sarasota, State of Florida. Unless the certificate is redeemed according to law, the property described in the certificate will be sold to the highest bidder at the Sarasota County Court House, 2000 Main Street, Historic Courtroom, East Wing, Sarasota, Florida, at 9:00 a.m. on the 1ST day of JULY, 2014.

Karen E. Rushing
Clerk Of The Circuit Court
Sarasota County, Florida
By: T. Lake, Deputy Clerk
Publication Dates: MAY 30; JUNE 6, 13, 20 2014

14-02480S

FIRST INSERTION

NOTICE OF APPLICATION FOR TAX DEED

Notice is hereby given that US BANK CUSTODIAN FOR TRC-SPE, the holder of the certificate listed below, has filed said certificate for a tax deed to be issued. The certificate number and year of issuance, the description of the property, and the names in which the property is assessed are as follows:

Certificate Number: 12476.000
Year of Issuance: 2011
Tax Deed File #: 14-0111 TD

Description of Property: 2020070043 LOT 15 BLK H AMARYLLIS PARK OR 2107/1050 2493/1714
Name in which the property is assessed: PEARLENE A STEPHENS
All of said property being in the County of Sarasota, State of Florida. Unless the certificate is redeemed according to law, the property described in the certificate will be sold to the highest bidder at the Sarasota County Court House, 2000 Main Street, Historic Courtroom, East Wing, Sarasota, Florida, at 9:00 a.m. on the 1ST day of JULY, 2014.

Karen E. Rushing
Clerk Of The Circuit Court
Sarasota County, Florida
By: T. Lake, Deputy Clerk
Publication Dates: MAY 30; JUNE 6, 13, 20 2014

14-02485S

FIRST INSERTION

NOTICE OF APPLICATION FOR TAX DEED

Notice is hereby given that FL COMM BANK CLTRL ASGNE OF MAGNOLIA TC 4 TDA, LLC, the holder of the certificate listed below, has filed said certificate for a tax deed to be issued. The certificate number and year of issuance, the description of the property, and the names in which the property is assessed are as follows:

Certificate Number: 278.000
Year of Issuance: 2012
Tax Deed File #: 14-0089 TD

Description of Property: 0028130034 LOT 11 BLK B NEWTOWN TERRACE
Name in which the property is assessed: ROBERT C S PEACOCK
All of said property being in the County of Sarasota, State of Florida. Unless the certificate is redeemed according to law, the property described in the certificate will be sold to the highest bidder at the Sarasota County Court House, 2000 Main Street, Historic Courtroom, East Wing, Sarasota, Florida, at 9:00 a.m. on the 1ST day of JULY, 2014.

Karen E. Rushing
Clerk Of The Circuit Court
Sarasota County, Florida
By: T. Lake, Deputy Clerk
Publication Dates: MAY 30; JUNE 6, 13, 20 2014

14-02472S

FIRST INSERTION

NOTICE OF APPLICATION FOR TAX DEED

Notice is hereby given that FL COMM BANK CLTRL ASGNE OF MAGNOLIA TC 4 TDA, LLC, the holder of the certificate listed below, has filed said certificate for a tax deed to be issued. The certificate number and year of issuance, the description of the property, and the names in which the property is assessed are as follows:

Certificate Number: 4568.000
Year of Issuance: 2012
Tax Deed File #: 14-0091 TD

Description of Property: 0853070006 N 20 FT OF LOT 23 & ALL OF LOT 24, BLK D, DEER CREEK PARK UNIT 1
Name in which the property is assessed: JUDITH C CATALAN & ANDREW CATALAN
All of said property being in the County of Sarasota, State of Florida. Unless the certificate is redeemed according to law, the property described in the certificate will be sold to the highest bidder at the Sarasota County Court House, 2000 Main Street, Historic Courtroom, East Wing, Sarasota, Florida, at 9:00 a.m. on the 1ST day of JULY, 2014.

Karen E. Rushing
Clerk Of The Circuit Court
Sarasota County, Florida
By: T. Lake, Deputy Clerk
Publication Dates: MAY 30; JUNE 6, 13, 20 2014

14-02474S

FIRST INSERTION

NOTICE OF APPLICATION FOR TAX DEED

Notice is hereby given that FL COMM BANK CLTRL ASGNE OF MAGNOLIA TC 4 TDA, LLC, the holder of the certificate listed below, has filed said certificate for a tax deed to be issued. The certificate number and year of issuance, the description of the property, and the names in which the property is assessed are as follows:

Certificate Number: 7424.000
Year of Issuance: 2012
Tax Deed File #: 14-0092 TD

Description of Property: 0995191626 LOT 26 BLK 1916 41ST ADD TO PORT CHARLOTTE ORI 2007048240
Name in which the property is assessed: LUBOW GERNAT & ROBERT A GERNAT
All of said property being in the County of Sarasota, State of Florida. Unless the certificate is redeemed according to law, the property described in the certificate will be sold to the highest bidder at the Sarasota County Court House, 2000 Main Street, Historic Courtroom, East Wing, Sarasota, Florida, at 9:00 a.m. on the 1ST day of JULY, 2014.

Karen E. Rushing
Clerk Of The Circuit Court
Sarasota County, Florida
By: T. Lake, Deputy Clerk
Publication Dates: MAY 30; JUNE 6, 13, 20 2014

14-02475S

FIRST INSERTION

NOTICE OF ACTION - (Constructive Service-Property) IN THE CIRCUIT COURT OF THE 12th JUDICIAL CIRCUIT, IN AND FOR SARASOTA COUNTY, FLORIDA GENERAL JURISDICTION DIVISION

CASE NO. 2014 CA 001780 NC BANK OF AMERICA, N.A., PLAINTIFF, VS. DENIS A MINTZE AKA DENIS MINTZE, ET AL., DEFENDANT(S). TO: SUN MINTZE LAST KNOWN ADDRESS: 17331 SEYMOUR AVE, PORT CHARLOTTE, FL 33953

YOU ARE HEREBY NOTIFIED that an action to foreclose a mortgage on the following real property, lying and being and situated in Sarasota County, Florida, more particularly described as follows:

LOT 26, BLOCK 10, FIRST ADDITION TO NORTH PORT CHARLOTTE ESTATES, ACCORDING TO THE PLAT THEREOF RECORDED IN PLAT BOOK 19, PAGE 29, OF THE PUBLIC RECORDS OF SARASOTA COUNTY, FLORIDA. COMMONLY KNOWN AS: Lot 26 Dunbarton Rd, North Port, FL 34286

Attorney file number: 14-09890 has been filed against you and you are required to serve a copy of your written defense, if any, to it on Pendergast & Morgan, P.A., the Plaintiff's attorney, whose address is 115 Perimeter Cen-

ter Place, South Terraces Suite 1000, Atlanta, Georgia 30346, within thirty (30) days of the first publication. Please file the original with the Clerk of this Court either before service on the Plaintiff's attorney or immediately thereafter; otherwise a default will be entered against you for the relief demanded in the Complaint.

This notice shall be published once a week for two consecutive weeks in the Business Observer.

If you are a person with a disability who needs any accommodation in order to participate in this proceeding, you are entitled, at no cost to you, to the provision of certain assistance. Please contact the Sarasota County Jury Office, P.O. Box 3079, Sarasota, Florida 34230-3079, (941)861-7400, at least seven (7) days before your scheduled court appearance, or immediately upon receiving this notification if the time before the scheduled appearance is less than seven (7) days; if you are hearing or voice impaired, call 711.

WITNESS my hand and the seal of this Court at Sarasota County, Florida, on the 22 day of May, 2014.

Clerk Name: KAREN E. RUSHING As Clerk, Circuit Court Sarasota County, Florida (SEAL) BY: C. Brandenburg As Deputy Clerk

Pendergast & Morgan, P.A. The Plaintiff's attorney 115 Perimeter Center Place, South Terraces, Suite 1000 Atlanta, Georgia 30346 14-09890 May 30; June 6, 2014 14-02398S

NOTICE OF ACTION- FORECLOSURE PROCEEDINGS IN THE CIRCUIT COURT OF THE TWELFTH JUDICIAL CIRCUIT IN AND FOR SARASOTA COUNTY, FLORIDA

CASE NO. : 58 2012 CA 006024 NC ING Bank, F.S.B., Plaintiff(s), vs. RICHARD H. PECORELLI, A/K/A RICHARD H. PECORELLI; et al., Defendant(s).

TO: RICHARD H. PECORELLI, A/K/A RICHARD PECORELLI and DOLORIA PECORELLI, including any unknown spouse of the Defendant, if remarried, and if said Defendant is dead, his/her respective unknown spouse, heirs, devisees, grantees, assignees, creditors, lien holders, and trustees, and all other persons claiming by, through, under or against the named Defendant; and the aforementioned named Defendants and such of the aforementioned unknown Defendant and such of the unknown named Defendant as may be infants, incompetents, or other not sui juris.

YOU ARE HEREBY NOTIFIED that an action to foreclose a mortgage on the following described property to-wit:

Lot 15, Oak Ford Phase I, according to the plat thereof, recorded in Plat Book 31, pages 5-5P, of the Public Records of Sarasota County, Florida. More commonly known as 797 Oak Bend Way, Sarasota, FL 34240.

This action has been filed against you, and you are required to serve a copy of

your written defense, if any, to it on Plaintiff's attorney, Burr & Forman LLP, whose address is 450 East Las Olas Boulevard, Suite 700, Fort Lauderdale, FL 33301, on or before 30 days after date of first publication, which is 6-30-2014, and file the original with the Clerk of the Circuit Court either before service on Plaintiff's attorney or immediately thereafter; otherwise a default will be entered against you for the relief demanded in the Complaint.

If you are a person with a disability who needs any accommodation in order to participate in this proceeding, you are entitled, at no cost to you, to the provision of certain assistance. Please contact the Sarasota County Jury Office, P.O. Box 3079, Sarasota, Florida 34230-3079, (941)861-7400, at least seven (7) days before your scheduled court appearance, or immediately upon receiving this notification if the time before the scheduled appearance is less than seven (7) days; if you are hearing or voice impaired, call 711.

Witness my hand and seal of this Court on the 15 day of May, 2014.

Karen E. Rushing, Clerk Sarasota County, Florida (SEAL) G. Kopinsky Deputy Clerk

Burr & Forman LLP Attorney for Plaintiff 450 East Las Olas Boulevard, Suite 700 Fort Lauderdale, FL 33301 Telephone No.: 954-414-6200 Facsimile: 954-414-6201 Email: flservice@burr.com May 30; June 6, 2014 14-02341S

SAVE TIME E-mail your Legal Notice

legal@businessobserverfl.com

Wednesday Noon Deadline • Friday Publication

Business Observer

FIRST INSERTION

NOTICE OF PUBLIC SALE
Value Self Storage located at 5150 University Parkway, Sarasota, FL 34243 hereby gives notice of a public sale to the highest bidder for cash only on or thereafter June 19, 2014 at 10:30 am in accordance with the Florida Self Storage Facility Act Statutes (section 83.801-83.809). Seller reserves the right to withdraw property from sale at any time. This property is being sold to satisfy a landlord lien. Property includes contents of the spaces of the following tenant: B212, Majewski,Shannon-HHG; B213,Majewski,Shannon-HHG; C3104,JTEC Enterprises,Inc.,-Business items, tool boxes; B2128, Henry Law-HHG,boxes,furniture. A1025 JTEC Enterprises-HHG. G741-Lisa A Buonaros,a,Karmann Ghia,bikes,HHG. May 30; June 6, 2014 14-02361S

FIRST INSERTION

Notice Under Fictitious Name Law Pursuant to Section 865.09, Florida Statutes
NOTICE IS HEREBY GIVEN that Thomas Ranch Land Partners North Port, LLLP, a Florida limited partnership, located at 200 South Orange Avenue, Sarasota, Florida 34236, County of Sarasota, intends to transact business under the fictitious name of Thomas Ranch Chipping and Mulching Facility, and to register the fictitious name with the Florida Division of Corporations. Dated this 21st day of May 2014.
May 30, 2014 14-02363S

FIRST INSERTION

NOTICE OF ACTION
DISSOLUTION OF MARRIAGE
IN THE CIRCUIT COURT OF THE
TWELFTH JUDICIAL CIRCUIT, IN
AND FOR SARASOTA COUNTY,
FLORIDA
Case No.: 14-DR-002560
Division: Family
In re: The Marriage of:
CARLA FOSTER-BERNARD
Petitioner/Wife,
and
EDWARD ALLAN KIRBY,
Respondent/Husband
TO: Edward Allan Kirby
{Respondent's last known address}
UNKNOWN

YOU ARE NOTIFIED that an action for Dissolution of Marriage has been filed against you and that you are required to serve a copy of your written defenses, if any, to it on Carla Foster-Bernard c/o Law Office of Jonathan Tolentino, PA, whose address is 501 Goodlette Rd. N. Ste D-100, Naples, FL 34102 on or before {date} 6-30-14, and file the original with the clerk of this Court at {clerk's address} 2000 Main Street, Sarasota, FL 34237 before service on Petitioner or immediately thereafter. If you fail to do so, a default may be entered against you for the relief demanded in the petition.

Copies of all court documents in this case, including orders, are available at the Clerk of the Circuit Court's office. You may review these documents upon request.

You must keep the Clerk of the Circuit Court's office notified of your current address. (You may file Notice of Current Address, Florida Supreme Court Approved Family Law Form 12.915.) Future papers in this lawsuit will be mailed to the address on record at the clerk's office.

WARNING: Rule 12.285, Florida Family Law Rules of Procedure, requires certain automatic disclosure of documents and information. Failure to comply can result in sanctions, including dismissal or striking of pleadings.

Please publish this Notice of Dissolution in the Business Observer.
Dated: 5-19-14.
KAREN E. RUSHING, CLERK
CLERK OF THE CIRCUIT COURT
(SEAL) By: L. Szymanski
Deputy Clerk

Carla Foster-Bernard c/o
Law Office of Jonathan Tolentino, PA
501 Goodlette Rd. N. Ste D-100
Naples, FL 34102
May 30; June 6, 13, 20, 2014
14-02364S

FIRST INSERTION

NOTICE OF PUBLIC SALE
Notice is hereby given that BIG JIM SELF STORAGE intends to sell the personal property described below to enforce a lien imposed on said property under the Florida Self Storage Facility Act statutes (Section 83.801-83.809). On or After June 19, 2014 at 12:30PM at BIG JIM SELF STORAGE 5109 Di-venti Ct. Sarasota FL 34232. Unit 2418 (Glenda Hunter) House hold goods
May 30; June 6, 2014 14-02448S

FIRST INSERTION

NOTICE OF PUBLIC SALE: J&G WFR Inc dba Direct Towing gives Notice of Foreclosure of Lien and intent to sell these vehicles on 6/6/2014 9:00:00 AM at 3951 N Osprey Ave, Sarasota, FL 34234 pursuant to subsection 713.78 of the Florida Statutes. J&G WFR Inc dba Direct Towing reserves the right to accept or reject any and/or all bids.
1GYEE637050135595 2005 CADI SRX
May 30, 2014 14-02362S

FIRST INSERTION

Notice Under Fictitious Name Law Pursuant to Section 865.09, Florida Statutes
NOTICE IS HEREBY GIVEN that the undersigned, desiring to engage in business under the fictitious name of ALPINE AIR CONDITIONING, HEATING & REFRIGERATION located at 410 Interstate Court, in the County of Sarasota, in the City of Sarasota, Florida 34240 intends to register the said name with the Division of Corporations of the Florida Department of State, Tallahassee, Florida.
Dated at Sarasota, Florida, this 22nd day of May, 2014.
EZE AIR SOLUTIONS, LLC
May 30, 2014 14-02414S

FIRST INSERTION

NOTICE OF PUBLIC SALE
PUBLIC NOTICE is hereby given, the personal property contents of the following rental units will be offered for sale by public auction to satisfy Sarasota Self Storage's lien at Sarasota Self Storage, 1169 N. Beneva Rd, Sarasota, FL 34232 on June, 19, 2014 at 11:30 am or thereafter. **TERMS:** CASH. We reserve the right to reject all bids. A \$50 cleaning deposit will be collected at the time of the sale and refunded after all contents of the units have been removed from the property.

#4009 - Anthony Miller - Household goods, furniture, boxes, sporting goods
#4130 - Allen Young - Household goods, furniture, boxes
#4133 - Branson Chrisman - Household goods, furniture, boxes
#4141 - Russell Hatt - Household goods, furniture, boxes, sporting goods
#4145 - Beth Gaudreau - Household goods, furniture, boxes
#4148 - Alejandro Santos - Household goods, furniture, boxes
#6008 - Mazie Rojas - Household goods, furniture, boxes
#6021 - Ashlee Rulison - Household goods, furniture, boxes
#6031 - Katy Chenkus - Household goods, furniture, boxes
#6252 - Malgorzata Jasiukiewicz - Household goods, furniture, boxes, sporting goods
#7315 - Mazie Rojas - Household goods, furniture, boxes
Ო - Ola Alyan - Household goods, furniture, boxes

The above information is to be published once a week for two consecutive weeks. Said sale to be under and by virtue of the statutes of the state of Florida in such cases made and provided.
LLA-03
May 30; June 6, 2014 14-02449S

FIRST INSERTION

PUBLIC SALE
NOTICE OF SALE OF ABANDONED PERSONAL PROPERTY is hereby given that pursuant to Florida Civil Code §1715 Synergy Partnerships Limited, will sell at PUBLIC SALE abandoned personal properties left by & where: Kim Nguyen 1512 Mellon Way Sarasota -Elizabeth E 1102 Olympia Rd Venice -Steven Durham 340 West Cowles Street Englewood -Michael W 429 50th St West Bradenton -FL. Items are being stored at 8250 N Tamiami Trail, Sarasota, FL.

Auction will take place on line at STORAGE BATTLES you must log on to storagebattles.com and register, enter this storage facilities address: 8250 N Tamiami Trail, Sarasota, FL. Auction ending time is 6/9/14 at 6 pm. Items to be auctioned may be but not limited to: household goods, personals, furniture, tools, yard garden, machinery, autos, building supplies & the unknown. For further information or questions call 951-676-8998
May 30; June 6, 2014 14-02459S

FIRST INSERTION

NOTICE UNDER FICTITIOUS NAME LAW
Pursuant to F.S. §865.09 **NOTICE IS HEREBY GIVEN** that the undersigned, desiring to engage in business under the fictitious name of xPoseBoudiour, located at 253 South Links Ave., in the City of Sarasota, County of Sarasota, State of Florida, 34236, intends to register the said name with the Division of Corporations of the Florida Department of State, Tallahassee, Florida. Dated this 27 of May, 2014.
STUDIO 41 LIMITED, INC.
253 South Links Ave.
Sarasota, FL 34236
May 30, 2014 14-02471S

FIRST INSERTION

NOTICE TO CREDITORS
IN THE CIRCUIT COURT FOR
SARASOTA COUNTY, FLORIDA
PROBATE DIVISION
File No. 2014-CP-001600
Division Probate
IN RE: ESTATE OF
THOMAS M. KAISER
Deceased.

The administration of the estate of THOMAS M. KAISER, deceased, whose date of death was March 13, 2014, is pending in the Circuit Court for Sarasota County, Florida, Probate Division, the address of which is 2000 Main Street, Sarasota, Florida 34237. The names and addresses of the personal representatives and the personal representative's attorney are set forth below.

All creditors of the decedent and other persons having claims or demands against decedent's estate on whom a copy of this notice is required to be served must file their claims with this court WITHIN THE LATER OF 3 MONTHS AFTER THE TIME OF THE FIRST PUBLICATION OF THIS NOTICE OR 30 DAYS AFTER THE DATE OF SERVICE OF A COPY OF THIS NOTICE ON THEM.

All other creditors of the decedent and other persons having claims or demands against decedent's estate must file their claims with this court WITHIN 3 MONTHS AFTER THE DATE OF THE FIRST PUBLICATION OF THIS NOTICE.

ALL CLAIMS NOT FILED WITHIN THE TIME PERIODS SET FORTH IN SECTION 733.702 OF THE FLORIDA PROBATE CODE WILL BE FOREVER BARRED.

NOTWITHSTANDING THE TIME PERIODS SET FORTH ABOVE, ANY CLAIM FILED TWO (2) YEARS OR MORE AFTER THE DECEDENT'S DATE OF DEATH IS BARRED.

The date of first publication of this notice is May 30, 2014.

Personal Representative:
JACQUELINE J. KAISER
2805 Sarasota Golf Club Blvd.
Sarasota, Florida 34240-9097
Attorney for Personal Representative:
ROBERT G. BLALOCK
Attorney
Florida Bar Number: 0006601
Blalock Walters, P.A.
802 11th Street West
Bradenton, Florida 34205-7734
Telephone: (941) 748-0100
Fax: (941) 745-2093
E-Mail: rblalock@blalockwalters.com
Secondary E-Mail: dgentry@blalockwalters.com
Alternate Secondary E-Mail: chuddleston@blalockwalters.com
818096/1
May 30; June 6, 2014 14-02357S

FIRST INSERTION

NOTICE TO CREDITORS
IN THE CIRCUIT COURT
FOR SARASOTA COUNTY,
FLORIDA
PROBATE DIVISION
File No. 2014CP1786NC
Division PROBATE
IN RE: ESTATE OF
BARBARA J. MEEHAN,
Deceased.

The administration of the estate of Barbara J. Meehan, deceased, whose date of death was April 10th, 2014, is pending in the Circuit Court for Sarasota County, Florida, Probate Division, the address of which is P.O. Box 3079, Sarasota, Florida 34230. The names and addresses of the personal representative and the personal representative's attorney are set forth below.

All creditors of the decedent and other persons having claims or demands against decedent's estate on whom a copy of this notice is required to be served must file their claims with this court ON OR BEFORE THE LATER OF 3 MONTHS AFTER THE TIME OF THE FIRST PUBLICATION OF THIS NOTICE OR 30 DAYS AFTER THE DATE OF SERVICE OF A COPY OF THIS NOTICE ON THEM.

All other creditors of the decedent and other persons having claims or demands against decedent's estate must file their claims with this court WITHIN 3 MONTHS AFTER THE DATE OF THE FIRST PUBLICATION OF THIS NOTICE.

ALL CLAIMS NOT FILED WITHIN THE TIME PERIODS SET FORTH IN SECTION 733.702 OF THE FLORIDA PROBATE CODE WILL BE FOREVER BARRED.

NOTWITHSTANDING THE TIME PERIODS SET FORTH ABOVE, ANY CLAIM FILED TWO (2) YEARS OR MORE AFTER THE DECEDENT'S DATE OF DEATH IS BARRED.

The date of first publication of this notice is May 30, 2014.

Personal Representative:
Terry L. Roberts
4111 Gerwe Road,
Sarasota, FL 34235
ROBERT W. DARNELL
ATTORNEY AT LAW
Attorneys for
Personal Representative
2639 FRUITVILLE ROAD
SUITE 201
SARASOTA, FL 34237
Florida Bar No. 0611999
May 30; June 6, 2014 14-02358S

FIRST INSERTION

NOTICE TO CREDITORS
IN THE CIRCUIT COURT FOR
SARASOTA COUNTY, FLORIDA
PROBATE DIVISION
File No. 2014-CP-001955-NC
Division: PROBATE
IN RE: ESTATE OF
STUART KRUPKIN,
Deceased.

The administration of the estate of Stuart Krupkin, deceased, whose date of death was March 31, 2014, is pending in the Circuit Court for Sarasota County, Florida, Probate Division, the address of which is 2000 Main Street, Sarasota, Florida 34237. The names and addresses of the personal representative and the personal representative's attorney are set forth below.

All creditors of the decedent and other persons having claims or demands against decedent's estate on whom a copy of this notice is required to be served must file their claims with this court WITHIN THE LATER OF 3 MONTHS AFTER THE TIME OF THE FIRST PUBLICATION OF THIS NOTICE OR 30 DAYS AFTER THE DATE OF SERVICE OF A COPY OF THIS NOTICE ON THEM.

All other creditors of the decedent and other persons having claims or demands against decedent's estate must file their claims with this court WITHIN 3 MONTHS AFTER THE DATE OF THE FIRST PUBLICATION OF THIS NOTICE.

ALL CLAIMS NOT FILED WITHIN THE TIME PERIODS SET FORTH IN SECTION 733.702 OF THE FLORIDA PROBATE CODE WILL BE FOREVER BARRED.

NOTWITHSTANDING THE TIME PERIODS SET FORTH ABOVE, ANY CLAIM FILED TWO (2) YEARS OR MORE AFTER THE DECEDENT'S DATE OF DEATH IS BARRED.

The date of first publication of this notice is May 30, 2014.

Personal Representatives:
Alex B. Krupkin,
Co-Personal Representative
and
Michelle C. Krupkin,
Co-Personal Representative
Attorney for Personal Representative:
L. Howard Payne, Esq.
Attorney
Florida Bar Number: 0061952
PAYNE LAW GROUP, P.A.
240 S Pineapple Ave, Suite 401
Sarasota, FL 34236
Telephone: (941) 487-2800
Fax: (941) 487-2801
E-Mail: hpayne@lawnav.com
Secondary E-Mail: amartinez@lawnav.com
May 30; June 6, 2014 14-02445S

FIRST INSERTION

NOTICE TO CREDITORS
IN THE CIRCUIT COURT
FOR SARASOTA COUNTY,
FLORIDA
PROBATE DIVISION
File No. 2014 CP 001880 NC
IN RE: ESTATE OF
HEIDI TURNER
Deceased.

The administration of the estate of HEIDI TURNER, deceased, whose date of death was April 16, 2014, is pending in the Circuit Court for Sarasota County, Florida, Probate Division, the address of which is Probate Division, Sarasota County Courthouse, 2000 Main Street, Sarasota, Florida 34236. The name and address of the personal representative and the personal representative's attorney are set forth below.

All creditors of the decedent and other persons having claims or demands against decedent's estate on whom a copy of this notice is required to be served must file their claims with this court WITHIN THE LATER OF 3 MONTHS AFTER THE TIME OF THE FIRST PUBLICATION OF THIS NOTICE OR 30 DAYS AFTER THE DATE OF SERVICE OF A COPY OF THIS NOTICE ON THEM.

All other creditors of the decedent and other persons having claims or demands against decedent's estate must file their claims with this court WITHIN 3 MONTHS AFTER THE DATE OF THE FIRST PUBLICATION OF THIS NOTICE.

ALL CLAIMS NOT SO FILED WILL BE FOREVER BARRED.

NOTWITHSTANDING THE TIME PERIOD SET FORTH ABOVE, ANY CLAIM FILED TWO (2) YEARS OR MORE AFTER THE DECEDENT'S DATE OF DEATH IS BARRED.

The date of first publication of this notice is May 30, 2014.

Robert M. Johnson
Personal Representative of
The Estate of Heidi Turner
One North Tuttle Avenue
Sarasota, Florida 34237
(941)906-1480
Robert M. Johnson, Esquire
Attorney for
the Personal
Representative
Florida Bar No. 0040000
2639 FRUITVILLE ROAD
SUITE 201
SARASOTA, FL 34237
Sarasota, Florida 34237
(941) 906-1480
May 30; June 6, 2014 14-02365S

FIRST INSERTION

NOTICE TO CREDITORS
IN THE CIRCUIT COURT FOR
SARASOTA COUNTY, FLORIDA
PROBATE DIVISION
File No. 2014-CP-1717-NC
Division: PROBATE
IN RE: ESTATE OF
GIOVANNINA T. WASHBURN
Deceased.

The administration of the estate of GIOVANNINA T. WASHBURN, deceased, whose date of death was February 15, 2014, is pending in the Circuit Court for SARASOTA County, Florida, Probate Division, the address of which is 2000 Main Street, Sarasota, Florida 34237. The names and addresses of the personal representative and the personal representative's attorney are set forth below.

All creditors of the decedent and other persons having claims or demands against decedent's estate on whom a copy of this notice is required to be served must file their claims with this court WITHIN THE LATER OF 3 MONTHS AFTER THE TIME OF THE FIRST PUBLICATION OF THIS NOTICE OR 30 DAYS AFTER THE DATE OF SERVICE OF A COPY OF THIS NOTICE ON THEM.

All other creditors of the decedent and other persons having claims or demands against decedent's estate must file their claims with this court WITHIN 3 MONTHS AFTER THE DATE OF THE FIRST PUBLICATION OF THIS NOTICE.

ALL CLAIMS NOT FILED WITHIN THE TIME PERIODS SET FORTH IN SECTION 733.702 OF THE FLORIDA PROBATE CODE WILL BE FOREVER BARRED.

NOTWITHSTANDING THE TIME PERIODS SET FORTH ABOVE, ANY CLAIM FILED TWO (2) YEARS OR MORE AFTER THE DECEDENT'S DATE OF DEATH IS BARRED.

The date of first publication of this notice is May 30, 2014.

Personal Representative
PETER DOYLE
41 Hill Avenue
Wallingford, Connecticut 06492
Attorney for Personal Representative:
MARY A. BYRSKI
Attorney
Florida Bar Number: 0166413
25086 Olympia Ave.
Ste 310
Punta Gorda, FL 33950
Telephone: (941) 833-9262
Fax: (941) 833-9264
E-Mail: mary@byrskilaw.com
Secondary E-Mail:
kaye@byrskilaw.com
May 30; June 6, 2014 14-02409S

FIRST INSERTION

NOTICE TO CREDITORS
IN THE CIRCUIT COURT FOR
SARASOTA COUNTY, FLORIDA
PROBATE DIVISION
File No. 2014CP-1916-NC
Division: Probate
IN RE: ESTATE OF
ELLY E. MANN,
Deceased.

The administration of the estate of ELLY E. MANN, deceased, whose date of death was April 4, 2014; is pending in the Circuit Court for Sarasota County, Florida, Probate Division, Case No: 2014-CP 1916NC the address of which is P.O. Box 3079, Sarasota, FL 34230. The names and addresses of the personal representative and the personal representative's attorney are set forth below.

All creditors of the decedent and other persons having claims or demands against decedent's estate on whom a copy of this notice is required to be served must file their claims with this court ON OR BEFORE THE LATER OF 3 MONTHS AFTER THE TIME OF THE FIRST PUBLICATION OF THIS NOTICE OR 30 DAYS AFTER THE DATE OF SERVICE OF A COPY OF THIS NOTICE ON THEM.

All other creditors of the decedent and other persons having claims or demands against decedent's estate must file their claims with this court WITHIN 3 MONTHS AFTER THE DATE OF THE FIRST PUBLICATION OF THIS NOTICE.

ALL CLAIMS NOT FILED WITHIN THE TIME PERIODS SET FORTH IN SECTION 733.702 OF THE FLORIDA PROBATE CODE WILL BE FOREVER BARRED.

NOTWITHSTANDING THE TIME PERIOD SET FORTH ABOVE, ANY CLAIM FILED TWO (2) YEARS OR MORE AFTER THE DECEDENT'S DATE OF DEATH IS BARRED.

The date of first publication of this notice is: May 30, 2014.

H. GREG LEE
Personal Representative
2014 Fourth Street
Sarasota, FL 34237
H. Greg Lee
Attorney for Personal Representative
Email: hglee@hgleglee.com
Florida Bar No. 351301
H. GREG LEE, P.A.
2014 Fourth Street
Sarasota, Florida 34237
Telephone: (941) 954-0067
Facsimile: (941) 365-1492
May 30; June 6, 2014 14-02359S

FIRST INSERTION

NOTICE TO CREDITORS
IN THE CIRCUIT COURT
FOR SARASOTA COUNTY,
FLORIDA
PROBATE DIVISION
File No. 2014 CP 1849 NC
IN RE: ESTATE OF
ADRIAN K. FULMER
a/k/a ADRIAN KEITH FULMER
Deceased.

The administration of the estate of Adrian K. Fulmer a/k/a Adrian Keith Fulmer, deceased, whose date of death was March 21st, 2014, is pending in the Circuit Court for Sarasota County, Florida, Probate Division, the address of which is PO Box 3079, 2000 Main St. Sarasota, FL 34230. The names and addresses of the personal representative and the personal representative's attorney are set forth below.

All creditors of the decedent and other persons having claims or demands against decedent's estate on whom a copy of this notice is required to be served must file their claims with this court ON OR BEFORE THE LATER OF 3 MONTHS AFTER THE TIME OF THE FIRST PUBLICATION OF THIS NOTICE OR 30 DAYS AFTER THE DATE OF SERVICE OF A COPY OF THIS NOTICE ON THEM.

All other creditors of the decedent and other persons having claims or demands against decedent's estate must file their claims with this court WITHIN 3 MONTHS AFTER THE DATE OF THE FIRST PUBLICATION OF THIS NOTICE.

ALL CLAIMS NOT FILED WITHIN THE TIME PERIODS SET FORTH IN SECTION 733.702 OF THE FLORIDA PROBATE CODE WILL BE FOREVER BARRED.

NOTWITHSTANDING THE TIME PERIODS SET FORTH ABOVE, ANY CLAIM FILED TWO (2) YEARS OR MORE AFTER THE DECEDENT'S DATE OF DEATH IS BARRED.

The date of first publication of this notice is May 30, 2014.

Personal Representative:
Pamela Fulmer Ysidron
12713 Trucius Place
Tampa, FL 33625
ERIK R. LIEBERMAN, ESQ.
KANETSKY, MOORE
& DEBOER, P.A.
ATTORNEYS AT LAW
Attorneys for Personal Representative
227 S. NOKOMIS AVE.
P.O. BOX 1767
VENICE, FL 34284-1767
Florida Bar No. 393053
May 30; June 6, 2014 14-02366S

FIRST INSERTION

NOTICE TO CREDITORS
IN THE CIRCUIT COURT FOR
SARASOTA COUNTY, FLORIDA
PROBATE DIVISION
File Number 2014 CP 002005 NC
IN RE: ESTATE OF
DONALD J. SCHOLTEN,
Deceased.

The administration of the ESTATE OF DONALD J. SCHOLTEN, deceased, whose date of death was May 6, 2014, is pending in the Circuit Court for Sarasota County, Florida, Probate Division, the address of which is P.O. Box 3079, Sarasota, Florida 34230. The names and addresses of the personal representative and the personal representative's attorney are set forth below.

All creditors of the decedent and other persons having claims or demands against decedent's estate on whom a copy of this notice is required to be served must file their claims with this court WITHIN THE LATER OF 3 MONTHS AFTER THE TIME OF THE FIRST PUBLICATION OF THIS NOTICE OR 30 DAYS AFTER THE DATE OF SERVICE OF A COPY OF THIS NOTICE ON THEM.

All other creditors of the decedent and other persons having claims or demands against decedent's estate must file their claims with this court WITHIN 3 MONTHS AFTER THE DATE OF THE FIRST PUBLICATION OF THIS NOTICE.

ALL CLAIMS NOT FILED WITHIN THE TIME PERIODS SET FORTH IN SECTION 733.702 OF THE FLORIDA PROBATE CODE WILL BE FOREVER BARRED.

NOTWITHSTANDING THE TIME PERIODS SET FORTH ABOVE, ANY CLAIM FILED TWO (2) YEARS OR MORE AFTER THE DECEDENT'S DATE OF DEATH IS BARRED.

The date of first publication of this notice is May 30, 2014.

Personal Representative:
HEIDI SHEA
c/o P. O. BOX 3018
Sarasota, Florida 34230
Attorney for Personal Representative:
JAMES O. FERGUSON, JR.
Florida Bar No. 171298
FERGUSON, SKIPPER, SHAW,
KEYSER, BARON & TIRABASSI, P.A.
1515 Ringling Boulevard, 10th Floor
P. O. Box 3018
Sarasota, Florida 34230-3018
(941) 957-1900
jferguson@fergusonkipper.com
services@fergusonkipper.com
5990884.27192
May 30; June 6, 2014 14-02412S

FIRST INSERTION

NOTICE TO CREDITORS
IN THE CIRCUIT COURT FOR
SARASOTA COUNTY, FLORIDA
PROBATE DIVISION
File No. 2014-CP-001307-NC
Division: PROBATE
IN RE: ESTATE OF
CHARLES WILLIAM PRICE,
Deceased.

The administration of the estate of Charles William Price, deceased, whose date of death was February 24, 2014, is pending in the Circuit Court for Sarasota County, Florida, Probate Division, the address of which is 2000 Main Street, Sarasota, Florida 34236. The names and addresses of the personal representative and the personal representative's attorney are set forth below.

All creditors of the decedent and other persons having claims or demands against decedent's estate on whom a copy of this notice is required to be served must file their claims with this court WITHIN THE LATER OF 3 MONTHS AFTER THE TIME OF THE FIRST PUBLICATION OF THIS NOTICE OR 30 DAYS AFTER THE DATE OF SERVICE OF A COPY OF THIS NOTICE ON THEM.

All other creditors of the decedent and other persons having claims or demands against decedent's estate must file their claims with this court WITHIN 3 MONTHS AFTER THE DATE OF THE FIRST PUBLICATION OF THIS NOTICE.

ALL CLAIMS NOT FILED WITHIN THE TIME PERIODS SET FORTH IN SECTION 733.702 OF THE FLORIDA PROBATE CODE WILL BE FOREVER BARRED.

NOTWITHSTANDING THE TIME PERIODS SET FORTH ABOVE, ANY CLAIM FILED TWO (2) YEARS OR MORE AFTER THE DECEDENT'S DATE OF DEATH IS BARRED.

The date of first publication of this notice is May 30, 2014.

Personal Representative:
Bradley Robertson

c/o The Payne Law Group
Attorney for Personal Representative:
L. Howard Payne, Esq.
Attorney
Florida Bar Number: 0061952
PAYNE LAW GROUP, P.A.
240 S Pineapple Ave,
Suite 401
Sarasota, FL 34236
Telephone: (941) 487-2800
Fax: (941) 487-2801
E-Mail: hpayne@lawnav.com
Secondary E-Mail:
amartinez@lawnav.com
May 30; June 6, 2014 14-02413S

FIRST INSERTION

NOTICE TO CREDITORS
IN THE CIRCUIT COURT FOR
SARASOTA COUNTY, FLORIDA
PROBATE DIVISION
File No. 2014 CP 1840 NC
IN RE: ESTATE OF
STEPHEN S. FINKEL,
Deceased.

The administration of the estate of STEPEHN S. FINKEL, deceased, whose date of death was April 9, 2014, is pending in the Circuit Court for Sarasota County, Florida, Probate Division, the address of which is PO Box 3079, Sarasota, FL 34230. The names and addresses of the personal representative and the personal representative's attorney are set forth below.

All creditors of the decedent and other persons having claims or demands against decedent's estate on whom a copy of this notice is required to be served must file their claims with this court ON OR BEFORE THE LATER OF 3 MONTHS AFTER THE TIME OF THE FIRST PUBLICATION OF THIS NOTICE OR 30 DAYS AFTER THE DATE OF SERVICE OF A COPY OF THIS NOTICE ON THEM.

All other creditors of the decedent and other persons having claims or demands against decedent's estate must file their claims with this court WITHIN 3 MONTHS AFTER THE DATE OF THE FIRST PUBLICATION OF THIS NOTICE.

ALL CLAIMS NOT FILED WITHIN THE TIME PERIODS SET FORTH IN SECTION 733.702 OF THE FLORIDA PROBATE CODE WILL BE FOREVER BARRED.

NOTWITHSTANDING THE TIME PERIOD SET FORTH ABOVE, ANY CLAIM FILED TWO (2) YEARS OR MORE AFTER THE DECEDENT'S DATE OF DEATH IS BARRED.

The date of first publication of this notice is May 30, 2014.

Personal Representative:
JOYCE HART

96 S. Washington Drive
Sarasota, FL 34236
Attorney for Personal Representative:
SUSAN B. HECKER
Florida Bar No. 0948380
Williams Parker Harrison
Dietz & Getzen
200 S. Orange Ave.
Sarasota, FL 34236
Telephone: 941-366-4800
Designation of
Email Addresses for service:
Primary: shecker@williamsparke.com
Secondary:
tpanozzo@williamsparke.com
May 30; June 6, 2014 14-02447S

FIRST INSERTION

NOTICE TO CREDITORS
IN THE CIRCUIT COURT FOR
SARASOTA COUNTY, FLORIDA
PROBATE DIVISION
File No. 2014CP001972SC
Division Probate
IN RE: ESTATE OF
BETTY ANN SCHLESINGER
Deceased.

The administration of the estate of Betty Ann Schlesinger, deceased, whose date of death was October 9, 2013, is pending in the Circuit Court for Sarasota County, Florida, Probate Division, the address of which is R.L. Anderson Administration Center, 4000 S Tamiami Trail, Venice, FL 34293. The names and addresses of the personal representative and the personal representative's attorney are set forth below.

All creditors of the decedent and other persons having claims or demands against decedent's estate on whom a copy of this notice is required to be served must file their claims with this court WITHIN THE LATER OF 3 MONTHS AFTER THE TIME OF THE FIRST PUBLICATION OF THIS NOTICE OR 30 DAYS AFTER THE DATE OF SERVICE OF A COPY OF THIS NOTICE ON THEM.

All other creditors of the decedent and other persons having claims or demands against decedent's estate must file their claims with this court WITHIN 3 MONTHS AFTER THE DATE OF THE FIRST PUBLICATION OF THIS NOTICE.

ALL CLAIMS NOT FILED WITHIN THE TIME PERIODS SET FORTH IN SECTION 733.702 OF THE FLORIDA PROBATE CODE WILL BE FOREVER BARRED.

NOTWITHSTANDING THE TIME PERIODS SET FORTH ABOVE, ANY CLAIM FILED TWO (2) YEARS OR MORE AFTER THE DECEDENT'S DATE OF DEATH IS BARRED.

The date of first publication of this notice is May 30, 2014.

Personal Representative:
Susan K. Cline

2805 Appleleaf Road
North Port, Florida 34286
Attorney for Personal Representative:
Anthony G. Mowry
Attorney
Florida Bar Number: 107374
227 Pensacola Rd.
Venice, Florida 34285
Telephone: (941) 480-0333
Fax: (941) 486-4106
E-Mail: tony@mowrylawoffice.com
May 30; June 6, 2014 14-02360S

FIRST INSERTION

NOTICE TO CREDITORS
IN THE CIRCUIT COURT FOR
SARASOTA COUNTY, FLORIDA
PROBATE DIVISION
File Number: 2014 CP 001834 NC
IN RE: ESTATE OF
LOUISE D. KROLL, deceased

The administration of the estate of LOUISE D. KROLL, deceased, whose date of death was April 6, 2014 is pending in the Circuit Court for Sarasota County, Florida, Probate Division, the address of which is POST OFFICE BOX 3079, SARASOTA, FLORIDA 34230-3079. The names and addresses of the personal representative and the personal representative's attorney are set forth below.

All creditors of the decedent and other persons having claims or demands against decedent's estate on whom a copy of this notice is required to be served must file their claims with this court WITHIN THE LATER OF 3 MONTHS AFTER THE TIME OF THE FIRST PUBLICATION OF THIS NOTICE OR 30 DAYS AFTER THE DATE OF SERVICE OF A COPY OF THIS NOTICE ON THEM.

All other creditors of the decedent and other persons having claims or demands against decedent's estate must file their claims with this court WITHIN 3 MONTHS AFTER THE DATE OF THE FIRST PUBLICATION OF THIS NOTICE.

ALL CLAIMS NOT SO FILED WITHIN THE TIME PERIODS SET FORTH IN SECTION 733.702 OF THE FLORIDA PROBATE CODE WILL BE FOREVER BARRED.

NOTWITHSTANDING THE TIME PERIOD SET FORTH ABOVE, ANY CLAIM FILED TWO (2) YEARS OR MORE AFTER THE DECEDENT'S DATE OF DEATH IS BARRED.

The date of first publication of this notice is May 30, 2014.

Personal Representative:
CHRISTINE OBER

131 Dates Street
Page, AZ 86040
Attorney for Personal Representative:
Paul A. Moran of
PAUL A. MORAN, P.A.
Attorney for Personal Representative
Florida Bar No: 320137
46 N. Washington Boulevard
Suite 25
Sarasota, FL 34236-5928
(941) 955-1717
PAMoranEsq@aol.com
Darcipamoranlaw@gmail.com
May 30; June 6, 2014 14-02444S

FIRST INSERTION

NOTICE TO CREDITORS
IN THE CIRCUIT COURT FOR
SARASOTA COUNTY, FLORIDA
PROBATE DIVISION
File No. 14 CP 002039 NC
IN RE: ESTATE OF
BERNARD SHAPIRO
Deceased.

The administration of the estate of Bernard Shapiro, deceased, whose date of death was May 15th, 2014, is pending in the Circuit Court for Sarasota County, Florida, Probate Division, the address of which is P.O. Box 3079, Sarasota, Florida 34230. The names and addresses of the personal representative and the personal representative's attorney are set forth below.

All creditors of the decedent and other persons having claims or demands against decedent's estate on whom a copy of this notice is required to be served must file their claims with this court ON OR BEFORE THE LATER OF 3 MONTHS AFTER THE TIME OF THE FIRST PUBLICATION OF THIS NOTICE OR 30 DAYS AFTER THE DATE OF SERVICE OF A COPY OF THIS NOTICE ON THEM.

All other creditors of the decedent and other persons having claims or demands against decedent's estate must file their claims with this court WITHIN 3 MONTHS AFTER THE DATE OF THE FIRST PUBLICATION OF THIS NOTICE.

Personal Representative:
Steven Shapiro

51 Sequim Place
Port Townsend, WA 98368
SHUMAKER, LOOP &
KENDRICK, LLP
Attorneys for Personal Representative
P. O. BOX 49948
SARASOTA, FL 34230
Florida Bar No. 0089559
By: Benjamin R. Hanan, Esquire
May 30; June 6, 2014 14-02446S

FIRST INSERTION

NOTICE TO CREDITORS
(Summary Administration)
IN THE CIRCUIT COURT
FOR SARASOTA COUNTY,
FLORIDA

PROBATE DIVISION
File No.: 2014 CP 001942 SC

Division PROBATE
IN RE: ESTATE OF
THERESA M. SMILES
Deceased.

TO ALL PERSONS HAVING CLAIMS OR DEMANDS AGAINST THE ABOVE ESTATE:
You are hereby notified that an Order of Summary Administration has been entered in the estate of THERESA M. SMILES, deceased, by the Circuit Court for SARASOTA County, Florida, Probate Division, the address of which is 4000 S. Tamiami Trail, Venice, FL 34293; that the decedent's date of death was March 17, 2014; that the total value of the estate is less than \$75,000 and that the names and addresses of those to whom it has been assigned by such order are:

Name	Address
ANNETTE Z.P. ROSS, SUCCESSOR TRUSTEE OF THE HARRY F. SMILES AND THERESA M. SMILES REVOCABLE TRUST AGREEMENT, AS AMENDED AND RESTATED, MARCH 27, 2013	901 Venetia Bay Blvd. Suite 240 Venice, FL 34285

ALL INTERESTED PERSONS ARE NOTIFIED THAT:
All creditors of the estate of the decedent and persons having claims or demands against the estate of the decedent other than those for whom provision for full payment was made in the Order of Summary Administration must file their claims with this court WITHIN THE TIME PERIODS SET FORTH IN SECTION 733.702 OF THE FLORIDA PROBATE CODE. ALL CLAIMS AND DEMANDS NOT SO FILED WILL BE FOREVER BARRED. NOTWITHSTANDING ANY OTHER APPLICABLE TIME PERIOD, ANY CLAIM FILED TWO (2) YEARS OR MORE AFTER THE DECEDENT'S DATE OF DEATH IS BARRED.
The date of first publication of this Notice is May 30, 2014.

NOTIFIED THAT:

All creditors of the estate of the decedent and persons having claims or demands against the estate of the decedent other than those for whom provision for full payment was made in the Order of Summary Administration must file their claims with this court WITHIN THE TIME PERIODS SET FORTH IN SECTION 733.702 OF THE FLORIDA PROBATE CODE. ALL CLAIMS AND DEMANDS NOT SO FILED WILL BE FOREVER BARRED. NOTWITHSTANDING ANY OTHER APPLICABLE TIME PERIOD, ANY CLAIM FILED TWO (2) YEARS OR MORE AFTER THE DECEDENT'S DATE OF DEATH IS BARRED.
The date of first publication of this Notice is May 30, 2014.

Person Giving Notice:
**ANNETTE Z.P. ROSS,
Petitioner**

901 Venetia Bay Blvd.
Suite 240
Venice, FL 34285
Attorney for Person Giving Notice:
Annette Z.P. Ross
Attorney
Florida Bar Number: 0141259
901 Venetia Bay Blvd.,
Suite 240
Venice, FL 34285
Telephone: (941) 480-1948
Fax: (941) 480-9277
E-Mail: aross80974@aol.com
Secondary E-Mail:
lawofficeazpr@aol.com
May 30; June 6, 2014 14-02452S

FIRST INSERTION

NOTICE TO CREDITORS
IN THE CIRCUIT COURT
IN AND FOR
SARASOTA COUNTY, FLORIDA
PROBATE DIVISION
File No. 2014CP0626NC
IN RE: The Estate of
RALPH H. YOUNG, Deceased

The administration of the estate of Ralph H. Young, deceased, whose date of death was April 28, 2013, is pending in the Circuit Court for the Twelfth Circuit, Sarasota County, Florida, Probate Division, the address of which is 2000 Main Street, Sarasota, FL 34237. The names and addresses of the personal representative and the personal representative's attorney are set forth below.

All creditors of the decedent and other persons having claims or demands against decedent's estate on whom a copy of this notice is required to be served must file their claims with this court WITHIN THE LATER OF 3 MONTHS AFTER THE TIME OF THE FIRST PUBLICATION OF THIS NOTICE OR 30 DAYS AFTER THE DATE OF SERVICE OF A COPY OF THIS NOTICE ON THEM.

All other creditors of the decedent and other persons having claims or demands against decedent's estate must file their claims with this court WITHIN 3 MONTHS AFTER THE DATE OF THE FIRST PUBLICATION OF THIS NOTICE.

ALL CLAIMS NOT FILED WITHIN THE TIME PERIODS SET FORTH IN SECTION 733.702 OF THE FLORIDA PROBATE CODE WILL BE FOREVER BARRED.

NOTWITHSTANDING THE TIME PERIODS SET FORTH ABOVE, ANY CLAIM FILED TWO (2) YEARS OR MORE AFTER THE DECEDENT'S DATE OF DEATH IS BARRED.

The date of first publication of this notice is May 30, 2014.

Personal Representative:
Ralph C. Young

3481 - 4 Mile Road, N.E.
Grand Rapids, MI 49525
Attorney for
Personal Representative:
Kevin Pillion, Esq.
FL Bar No. 70288
Life Planning Law Firm, P.A.
1671 Mound Street
Sarasota, FL 34236
Telephone: (941) 914-6000
May 30; June 6, 2014 14-02367S

FIRST INSERTION

NOTICE TO CREDITORS
IN THE CIRCUIT COURT FOR
SARASOTA COUNTY, FLORIDA
PROBATE DIVISION
File No. 2014CP1806NC
Division PROBATE
IN RE: ESTATE OF
MICHAEL R. GUTOWSKI, SR.,
Deceased.

The administration of the estate of Michael R. Gutowski, Sr., deceased, whose date of death was April 23rd, 2014, is pending in the Circuit Court for Sarasota County, Florida, Probate Division, the address of which is P.O. Box 3079, Sarasota, Florida 34230. The names and addresses of the personal representative and the personal representative's attorney are set forth below.

All creditors of the decedent and other persons having claims or demands against decedent's estate on whom a copy of this notice is required to be served must file their claims with this court ON OR BEFORE THE LATER OF 3 MONTHS AFTER THE TIME OF THE FIRST PUBLICATION OF THIS NOTICE OR 30 DAYS AFTER THE DATE OF SERVICE OF A COPY OF THIS NOTICE ON THEM.

All other creditors of the decedent and other persons having claims or demands against decedent's estate must file their claims with this court WITHIN 3 MONTHS AFTER THE DATE OF THE FIRST PUBLICATION OF THIS NOTICE.

ALL CLAIMS NOT FILED WITHIN THE TIME PERIODS SET FORTH IN SECTION 733.702 OF THE FLORIDA PROBATE CODE WILL BE FOREVER BARRED.

NOTWITHSTANDING THE TIME PERIODS SET FORTH ABOVE, ANY CLAIM FILED TWO (2) YEARS OR MORE AFTER THE DECEDENT'S DATE OF DEATH IS BARRED.

The date of first publication of this notice is May 30, 2014.

Personal Representative:
Linda A. Rominski

2134 Brookhaven Drive,
Sarasota, FL 34239
ROBERT W. DARNELL
ATTORNEY AT LAW
Attorneys for Personal Representative
2639 FRUITVILLE ROAD
SUITE 201
SARASOTA, FL 34237
Florida Bar No. 0611999
May 30; June 6, 2014 14-02410S

FIRST INSERTION

NOTICE TO CREDITORS
IN THE CIRCUIT COURT FOR
SARASOTA COUNTY, FLORIDA
PROBATE DIVISION
File No. 2014 CP 1963 NC
IN RE: ESTATE OF
NANCY J. PECK, A/K/A
NANCY JANE PECK
Deceased.

The administration of the estate of NANCY J. PECK, A/K/A NANCY JANE PECK, deceased, whose date of death was April 16th, 2014, is pending in the Circuit Court for SARASOTA County, Florida, Probate Division, the address of which is Sarasota County Courthouse, Probate, Room 102, 2000 Main Street, Sarasota, FL 34237. The names and addresses of the personal representative and the personal representative's attorney are set forth below.

All creditors of the decedent and other persons having claims or demands against decedent's estate on whom a copy of this notice is required to be served must file their claims with this court ON OR BEFORE THE LATER OF 3 MONTHS AFTER THE TIME OF THE FIRST PUBLICATION OF THIS NOTICE OR 30 DAYS AFTER THE DATE OF SERVICE OF A COPY OF THIS NOTICE ON THEM.

All other creditors of the decedent and other persons having claims or demands against decedent's estate must file their claims with this court WITHIN 3 MONTHS AFTER THE DATE OF THE FIRST PUBLICATION OF THIS NOTICE.

ALL CLAIMS NOT FILED WITHIN THE TIME PERIODS SET FORTH IN SECTION 733.702 OF THE FLORIDA PROBATE CODE WILL BE FOREVER BARRED.

NOTWITHSTANDING THE TIME PERIODS SET FORTH ABOVE, ANY CLAIM FILED TWO (2) YEARS OR MORE AFTER THE DECEDENT'S DATE OF DEATH IS BARRED.

The date of first publication of this notice is May 30, 2014.

Personal Representative:
SUSAN M. SAGINS

13035 TIBBETS ROAD
RILEY, MI 48041
THOMAS W. HARRISON
HARRISON & KIRKLAND, P.A.
Attorneys for Personal Representative
1206 MANATEE AVENUE, WEST
BRADENTON, FL 34205
Florida Bar No. 334375
May 30; June 6, 2014 14-02411S

FIRST INSERTION

NOTICE TO CREDITORS
IN THE CIRCUIT COURT FOR
SARASOTA COUNTY, FLORIDA
PROBATE DIVISION
File No. 2014 CP 001721 SC
IN RE: ESTATE OF
DONNA A. COGSWELL
Deceased.

The administration of the estate of Donna A. Cogswell, deceased, whose date of death was November 14, 2013, is pending in the Circuit Court for Sarasota County, Florida, Probate Division, the address of which is P.O. Box 3079, Sarasota, Florida, 34230. The names and addresses of the personal representative and the personal representative's attorney are set forth below.

All creditors of the decedent and other persons having claims or demands against decedent's estate on whom a copy of this notice is required to be served must file their claims with this court WITHIN THE LATER OF 3 MONTHS AFTER THE TIME OF THE FIRST PUBLICATION OF THIS NOTICE OR 30 DAYS AFTER THE DATE OF SERVICE OF A COPY OF THIS NOTICE ON THEM.

All other creditors of the decedent and other persons having claims or demands against decedent's estate must file their claims with this court WITHIN 3 MONTHS AFTER THE DATE OF THE FIRST PUBLICATION OF THIS NOTICE.

ALL CLAIMS NOT FILED WITHIN THE TIME PERIODS SET FORTH IN SECTION 733.702 OF THE FLORIDA PROBATE CODE WILL BE FOREVER BARRED.

NOTWITHSTANDING THE TIME PERIODS SET FORTH ABOVE, ANY CLAIM FILED TWO (2) YEARS OR MORE AFTER THE DECEDENT'S DATE OF DEATH IS BARRED.

The date of first publication of this notice is May 30, 2014.

Personal Representative:
Ronald J. Cogswell

1073 Truman Street
Nokomis, Florida 34275
Attorney for Personal Representative:
Andrew J. Britton, Esq.
Florida Bar Number: 213500
401 Johnson Lane, Suite 102
Venice, FL 34285
Telephone: (941) 408-8008
Fax: (941) 408-0722
E-Mail: brittonlaw@gmail.com
Secondary E-Mail: FOR SERVICE OF DOCUMENTS
e-service@andrewbrittonlaw.com
May 30; April 6, 2014 14-02453S

FIRST INSERTION

NOTICE TO CREDITORS
(Amended Summary Administration)
IN THE CIRCUIT COURT FOR
SARASOTA COUNTY,
FLORIDA
PROBATE DIVISION
File No. 2014 CP 001583 NC
IN RE: ESTATE OF
MARGARET H. LEAHY,
Deceased.

TO ALL PERSONS HAVING CLAIMS OR DEMANDS AGAINST THE ABOVE ESTATE:

You are hereby notified that an Amended Order of Summary Administration has been entered in the Estate of Margaret H. Leahy, deceased, File No. 2014 CP 001583 NC, by the Circuit Court for Sarasota County, Florida, Probate Division, the address of which is 2000 Main Street, Room 102, Sarasota, FL 34237; that the decedent's date of death was March 21, 2014; that the total value of the estate is approximately \$28,852.00 (not including decedent's homestead); and that the names and addresses of those to whom it has been assigned by such amended order are:

Name	Address
Michael H. Leahy	3820 Klinge Place, NW, Washington, DC 20016
Mary L. Hatton	1411 Melbrook Drive, Munster, IN 46321

ALL INTERESTED PERSONS ARE NOTIFIED THAT:

All creditors of the estate of the decedent and persons having claims or

demands against the estate of the decedent other than those for whom provision for full payment was made in the Amended Order of Summary Administration must file their claims with this court WITHIN THE TIME PERIODS SET FORTH IN SECTION 733.702 OF THE FLORIDA PROBATE CODE. ALL CLAIMS AND DEMANDS NOT SO FILED WILL BE FOREVER BARRED. NOTWITHSTANDING ANY OTHER APPLICABLE TIME PERIOD, ANY CLAIM FILED TWO (2) YEARS OR MORE AFTER THE DECEDENT'S DATE OF DEATH IS BARRED.
The date of first publication of this Notice is: May 30, 2014.

Michael H. Leahy,
Personal Giving Notice

3820 Klinge Place, NW
Washington, DC 20016
Mary L. Hatton,
Personal Giving Notice
1411 Melbrook Drive
Munster, IN 46321

Keith B. Braun, Esq.
Attorney for Person Giving Notice
Florida Bar No. 0979724
Comiter, Singer, Baseman & Braun, LLP
3801 PGA Boulevard, Suite 604
Palm Beach Gardens, FL 33410
Primary Email:
legal-service@comitersinger.com
Secondary Email:
kbraun@comitersinger.com
Telephone: 561-626-2101
Fax: 561-626-4742
May 30; June 6, 2014 14-02443S

**PUBLISH YOUR
LEGAL NOTICES
IN THE BUSINESS OBSERVER**
(813) 221-9505 Hillsborough, Pasco
(727) 447-7784 Pinellas
(941) 906-9386 Manatee, Sarasota, Lee
(239) 263-0122 Collier
(941) 249-4900 Charlotte
(407) 654-5500 Orange

FIRST INSERTION

NOTICE TO CREDITORS
IN THE CIRCUIT COURT FOR
SARASOTA COUNTY, FLORIDA
PROBATE DIVISION
File No. 2013CP004353NC
Division Probate
IN RE: ESTATE OF
ALICIA STARKWEATHER
Deceased.

The administration of the estate of Alicia Starkweather, deceased, whose date of death was September 2, 2013, is pending in the Circuit Court for Sarasota County, Florida, Probate Division, the address of which is 2000 Main Street, Sarasota, Florida 34237. The names and addresses of the personal representative and the personal representative's attorney are set forth below.

All creditors of the decedent and other persons having claims or demands against decedent's estate on whom a copy of this notice is required to be served must file their claims with this court ON OR BEFORE THE LATER OF 3 MONTHS AFTER THE TIME OF THE FIRST PUBLICATION OF THIS NOTICE OR 30 DAYS AFTER THE DATE OF SERVICE OF A COPY OF THIS NOTICE ON THEM.

All other creditors of the decedent and other persons having claims or demands against decedent's estate must file their claims with this court WITHIN 3 MONTHS AFTER THE DATE OF THE FIRST PUBLICATION OF THIS NOTICE.

ALL CLAIMS NOT FILED WITHIN THE TIME PERIODS SET FORTH IN SECTION 733.702 OF THE FLORIDA PROBATE CODE WILL BE FOREVER BARRED.

NOTWITHSTANDING THE TIME PERIODS SET FORTH ABOVE, ANY CLAIM FILED TWO (2) YEARS OR MORE AFTER THE DECEDENT'S DATE OF DEATH IS BARRED.

The date of first publication of this notice is May 30, 2014.

Personal Representative:

Lubos Petratur
627 Prarie Lane
Altamonte Springs, Florida 32714
Attorney for Personal Representative:
David P. Johnson, Esq.
Florida Bar No. 525499
2201 Ringling Blvd.,
Suite 104
Sarasota, Florida 34237
(address)
May 30; June 6, 2014 14-02470S

FIRST INSERTION

NOTICE TO CREDITORS
IN THE CIRCUIT COURT OF THE
TWELFTH JUDICIAL CIRCUIT
IN AND FOR SARASOTA COUNTY
STATE OF FLORIDA
PROBATE DIVISION
File No.: 2014 CP 001166
IN RE: ESTATE OF
BETTY J. PAULL
Deceased.

The administration of the Estate of BETTY J. PAULL, deceased, whose date of death was December 28, 2013, is pending in the Circuit Court for Sarasota County Florida, Probate Division, the address of which is 2000 Main St, Sarasota, FL 34236, under File No: 2014 CP 001166. The name and address of the personal representative and the personal representative's attorney are set forth below.

All creditors of the decedent and other persons having claims or demands against the decedent's estate, on whom a copy of this Notice is required to be served must file their claims with this Court, WITHIN THE LATER OF THREE (3) MONTHS AFTER THE DATE OF THE FIRST PUBLICATION OF THIS NOTICE OR 30 DAYS AFTER THE DATE OF SERVICE OF A COPY OF THIS NOTICE ON THEM.

All other creditors of the decedent and other persons having claims or demands against the decedent's estate, must file their claims with this Court WITHIN THREE (3) MONTHS AFTER THE DATE OF THE FIRST PUBLICATION OF THIS NOTICE.

ALL CLAIMS NOT SO FILED WILL BE FOREVER BARRED.

NOTWITHSTANDING THE TIME PERIOD SET FORTH ABOVE, ANY CLAIM FILED TWO (2) YEARS OR MORE AFTER THE DECEDENT'S DATE OF DEATH IS BARRED.

Lynda M. Van Patten,

Personal Representative

1527 Vintage Lane
Naples, Florida 34104
Paul J. Bupivi
(FL Bar #94635)
Attorney for the
Personal Representative
LAWRENCE & ASSOCIATES
1990 Main Street -
Ste. 750
Sarasota, FL 34236
Tel. (941) 404-6360
Fax (941) 269-8689
pbupivi@lawrencelawoffices.com
May 30; June 6, 2014 14-02456S

FIRST INSERTION

NOTICE TO CREDITORS
IN THE CIRCUIT COURT FOR
SARASOTA COUNTY, FLORIDA
PROBATE DIVISION
File No. 2014-CP-001966-NC
Division PROBATE
IN RE: ESTATE OF
SANDRA JEAN MARIE SCOTT
Deceased.

The administration of the estate of SANDRA JEAN MARIE SCOTT, deceased, whose date of death was April 9, 2014, is pending in the Circuit Court for Sarasota County, Florida, Probate Division, the address of which is P.O. Box 3079, Sarasota, FL 34230. The names and addresses of the personal representative and the personal representative's attorney are set forth below.

All creditors of the decedent and other persons having claims or demands against decedent's estate on whom a copy of this notice is required to be served must file their claims with this court WITHIN THE LATER OF 3 MONTHS AFTER THE TIME OF THE FIRST PUBLICATION OF THIS NOTICE OR 30 DAYS AFTER THE DATE OF SERVICE OF A COPY OF THIS NOTICE ON THEM.

All other creditors of the decedent and other persons having claims or demands against decedent's estate must file their claims with this court WITHIN 3 MONTHS AFTER THE DATE OF THE FIRST PUBLICATION OF THIS NOTICE.

ALL CLAIMS NOT FILED WITHIN THE TIME PERIODS SET FORTH IN SECTION 733.702 OF THE FLORIDA PROBATE CODE WILL BE FOREVER BARRED.

NOTWITHSTANDING THE TIME PERIODS SET FORTH ABOVE, ANY CLAIM FILED TWO (2) YEARS OR MORE AFTER THE DECEDENT'S DATE OF DEATH IS BARRED.

The date of first publication of this notice is May 30, 2014.

Personal Representative:

Nicholas Scott
2484 Nodosa Drive
Sarasota, Florida 34232
Attorney for Personal Representative:
William B. Scovill, Esquire
Florida Bar Number: 0985716
5104 N. Lockwood Ridge Road,
Suite 102
Sarasota, FL 34234
Telephone: (941) 365-2253
Fax: (941) 706-4171
E-Mail: Bart@scovills.com
Secondary E-Mail:
Bettina@scovills.com
May 30; June 6, 2014 14-02457S

FIRST INSERTION

NOTICE OF FORECLOSURE SALE
IN THE CIRCUIT COURT OF THE
TWELFTH JUDICIAL CIRCUIT
IN AND FOR SARASOTA COUNTY,
FLORIDA
CIVIL ACTION
CASE NO.: 2009-CA-016525-NC
DIVISION: A
BANK OF AMERICA, N.A.,
Plaintiff, vs.
JOYCE A. SMITH, et al,
Defendant(s).

NOTICE IS HEREBY GIVEN pursuant to a Final Judgment of Mortgage Foreclosure dated May 19, 2014 and entered in Case No. 2009-CA-016525-NC of the Circuit Court of the TWELFTH Judicial Circuit in and for SARASOTA County, Florida wherein GREEN TREE SERVICING LLC, ¹ Plaintiff name has changed pursuant to order previously entered, is the Plaintiff and JOYCE A SMITH; are the Defendants, The Clerk will sell to the highest and best bidder for cash at WWW.SARASOTA.REALFORECLOSE.COM at 9:00AM, on the 18th day of August, 2014, the following described property as set forth in said Final Judgment: LOT 821, SARASOTA SPRINGS, UNIT 7, ACCORDING TO THE PLAT THEREOF, AS RECORDED IN PLAT BOOK 8, PAGE 21, OF THE PUBLIC RECORDS OF SARASOTA COUNTY, FLORIDA

A/K/A 4126 PRESCOTT STREET, SARASOTA, FL 34232

Any person claiming an interest in the surplus from the sale, if any, other than the property owner as of the date of the Lis Pendens must file a claim within sixty (60) days after the sale.

If you are a person with a disability who needs any accommodation in order to participate in this proceeding, you are entitled, at no cost to you, to the provision of certain assistance. Please contact the Sarasota County Jury Office, P.O. Box 3079, Sarasota, Florida 34230-3079, (941)861-7400, at least seven (7) days before your scheduled court appearance, or immediately upon receiving this notification if the time before the scheduled appearance is less than seven (7) days; if you are hearing or voice impaired, call 711.

By: J. Bennett Kitterman
Florida Bar No. 98636

Ronald R Wolfe & Associates, P.L.
P.O. Box 25018
Tampa, Florida 33622-5018
(813) 251-4766
(813) 251-1541 Fax
F09093256
May 30; June 6, 2014 14-02460S

FIRST INSERTION

NOTICE TO CREDITORS
IN THE CIRCUIT COURT FOR
SARASOTA COUNTY, FLORIDA
PROBATE DIVISION
File No. 2014CP1569NC
Division PROBATE
IN RE: ESTATE OF
RUDI O. WADLE,
Deceased.

The administration of the estate of Rudi O. Wadle, deceased, whose date of death was April 9th, 2014, is pending in the Circuit Court for Sarasota County, Florida, Probate Division, the address of which is P.O. Box 3079, Sarasota, Florida 34230. The names and addresses of the personal representative and the personal representative's attorney are set forth below.

All creditors of the decedent and other persons having claims or demands against decedent's estate on whom a copy of this notice is required to be served must file their claims with this court ON OR BEFORE THE LATER OF 3 MONTHS AFTER THE TIME OF THE FIRST PUBLICATION OF THIS NOTICE OR 30 DAYS AFTER THE DATE OF SERVICE OF A COPY OF THIS NOTICE ON THEM.

All other creditors of the decedent and other persons having claims or demands against decedent's estate must file their claims with this court WITHIN 3 MONTHS AFTER THE DATE OF THE FIRST PUBLICATION OF THIS NOTICE.

ALL CLAIMS NOT FILED WITHIN THE TIME PERIODS SET FORTH IN SECTION 733.702 OF THE FLORIDA PROBATE CODE WILL BE FOREVER BARRED.

NOTWITHSTANDING THE TIME PERIODS SET FORTH ABOVE, ANY CLAIM FILED TWO (2) YEARS OR MORE AFTER THE DECEDENT'S DATE OF DEATH IS BARRED.

The date of first publication of this notice is May 30, 2014.

Personal Representative:

Randi Craig Wadle
3719 4th Avenue NE,
Bradenton, FL 34208
Jeffrey Wadle
18307 Burbank Blvd., #333
Tarzana, CA 91356
Karen Wadle Lord
902 Rectory Court,
Wilmington, NC 28411
ROBERT W. DARNELL
ATTORNEY AT LAW
Attorneys for Personal Representative
2639 FRUITVILLE ROAD
SUITE 201
SARASOTA, FL 34237
Florida Bar No. 0611999
May 30; June 6, 2014 14-02455S

FIRST INSERTION

NOTICE TO CREDITORS
IN THE CIRCUIT COURT FOR
SARASOTA COUNTY, FLORIDA
PROBATE DIVISION
File No. 2014CP1245NC
Division PROBATE
IN RE: ESTATE OF
PETER LOMBARDO,
Deceased.

The administration of the estate of Peter Lombardo, deceased, whose date of death was February 19th, 2014, is pending in the Circuit Court for Sarasota County, Florida, Probate Division, the address of which is P.O. Box 3079, Sarasota, Florida 34230. The names and addresses of the personal representative and the personal representative's attorney are set forth below.

All creditors of the decedent and other persons having claims or demands against decedent's estate on whom a copy of this notice is required to be served must file their claims with this court ON OR BEFORE THE LATER OF 3 MONTHS AFTER THE TIME OF THE FIRST PUBLICATION OF THIS NOTICE OR 30 DAYS AFTER THE DATE OF SERVICE OF A COPY OF THIS NOTICE ON THEM.

All other creditors of the decedent and other persons having claims or demands against decedent's estate must file their claims with this court WITHIN 3 MONTHS AFTER THE DATE OF THE FIRST PUBLICATION OF THIS NOTICE.

ALL CLAIMS NOT FILED WITHIN THE TIME PERIODS SET FORTH IN SECTION 733.702 OF THE FLORIDA PROBATE CODE WILL BE FOREVER BARRED.

NOTWITHSTANDING THE TIME PERIODS SET FORTH ABOVE, ANY CLAIM FILED TWO (2) YEARS OR MORE AFTER THE DECEDENT'S DATE OF DEATH IS BARRED.

The date of first publication of this notice is May 30, 2014.

Personal Representative:

Caron Swartz
106 Saratoga Way NE,
Vienna, VA 22180
Dean Lombardo
72 Norwood Road,
North Port, NY 11768
Steven Lombardo
4179 Winners Circle, Apt. 422,
Sarasota, Florida 34238
ROBERT W. DARNELL
ATTORNEY AT LAW
Attorneys for Personal Representative
2639 FRUITVILLE ROAD
SUITE 201
SARASOTA, FL 34237
Florida Bar No. 0611999
May 30; June 6, 2014 14-02454S

FIRST INSERTION

NOTICE OF RESCHEDULED SALE
IN THE CIRCUIT COURT OF THE
TWELFTH JUDICIAL CIRCUIT
IN AND FOR SARASOTA COUNTY,
FLORIDA
CIVIL ACTION
CASE NO.: 2013 CA 007765 NC
WELLS FARGO BANK, N.A.,
Plaintiff, vs.
MILLER, SHERI et al,
Defendant(s).

NOTICE IS HEREBY GIVEN Pursuant to an Order Rescheduling Foreclosure Sale dated on or about April 29, 2014, and entered in Case No. 2013 CA 007765 NC of the Circuit Court of the Twelfth Judicial Circuit in and for Sarasota County, Florida in which Wells Fargo Bank, N.A., is the Plaintiff and PMorgan Chase Bank, National Association, Robert C. Miller, Sheri L. Miller, Tenant #1 n/k/a Dustin Robert Miller, are defendants, the Sarasota County Clerk of the Circuit Court will sell to the highest and best bidder for cash the Internet: www.sarasota.realforeclose.com in/on, Sarasota County, Florida at 9:00am on the 13th day of June, 2014, the following described property as set forth in said Final Judgment of Foreclosure:

LOTS 17057, 17056, AND THE WEST 1/2 OF LOT 17055, SOUTH VENICE, UNIT NO. 64, ACCORDING TO THE PLAT THEREOF RECORDED IN PLAT BOOK 7, PAGE 41, OF THE PUBLIC RECORDS OF SARASOTA COUNTY, FLORIDA

A/K/A 656 BRADENTON ROAD, VENICE, FL 34293

Any person claiming an interest in the surplus from the sale, if any, other than the property owner as of the date of the Lis Pendens must file a claim within 60 days after the sale.

If you are a person with a disability who needs any accommodation in order to participate in this proceeding, you are entitled, at no cost to you, to the provision of certain assistance. Please contact the Sarasota County Jury Office, P.O. Box 3079, Sarasota, Florida 34230-3079, (941)861-7400, at least seven (7) days before your scheduled court appearance, or immediately upon receiving this notification if the time before the scheduled appearance is less than seven (7) days; if you are hearing or voice impaired, call 711.

Albertelli Law
Attorney for Plaintiff
P.O. Box 23028
Tampa, FL 33623
(813) 221-4743
(813) 221-9171 facsimile
eService: servealaw@albertellilaw.com
BM - 13-120021
May 30; June 6, 2014 14-02340S

FIRST INSERTION

NOTICE TO CREDITORS
IN THE CIRCUIT COURT FOR
SARASOTA COUNTY, FLORIDA
PROBATE DIVISION
File No. 2014 CP 002063 NC
IN RE: ESTATE OF
PAUL Z. WOS
Deceased.

The administration of the estate of PAUL Z. WOS, deceased, whose date of death was December 2, 2013, is pending in the Circuit Court for Sarasota County, Florida, Probate Division, the address of which is 2000 Main Street, Sarasota, FL 34236. The names and addresses of the personal representatives and the personal representative's attorney are set forth below.

All creditors of the decedent and other persons having claims or demands against decedent's estate on whom a copy of this notice is required to be served must file their claims with this court WITHIN THE LATER OF 3 MONTHS AFTER THE TIME OF THE FIRST PUBLICATION OF THIS NOTICE OR 30 DAYS AFTER THE DATE OF SERVICE OF A COPY OF THIS NOTICE ON THEM.

All other creditors of the decedent and other persons having claims or demands against decedent's estate must file their claims with this court WITHIN 3 MONTHS AFTER THE DATE OF THE FIRST PUBLICATION OF THIS NOTICE.

ALL CLAIMS NOT FILED WITHIN THE TIME PERIODS SET FORTH IN SECTION 733.702 OF THE FLORIDA PROBATE CODE WILL BE FOREVER BARRED.

NOTWITHSTANDING THE TIME PERIOD SET FORTH ABOVE, ANY CLAIM FILED TWO (2) YEARS OR MORE AFTER THE DECEDENT'S DATE OF DEATH IS BARRED.

The date of first publication of this notice is May 30, 2014.

Personal Representatives:

KONRAD P. WOS
333 E. 43rd Street, PH 15
New York City, NY 10017
ALDONA Z. WOS
806 Country Club Drive
Greensboro, NC 27408
Attorney for Personal Representatives:
ELIZABETH J. BARBER
Attorney
Florida Bar Number: 0058183
DUNLAP & MORAN, P.A.
Post Office Box 3948
Sarasota, FL 34230
Telephone: (941) 366-0115
Fax: (941) 365-4660
E-Mail:
ebarber@dunlapmoran.com
EJB11861-2)Notice to Creditors
May 30; June 6, 2014 14-02466S

FIRST INSERTION

NOTICE TO CREDITORS
IN THE CIRCUIT COURT FOR
SARASOTA COUNTY, FLORIDA
PROBATE DIVISION
File No. 2014 CP 001998 NC
IN RE: ESTATE OF
NANCY L. BLAIR
a.k.a. NANCY LYNN BLAIR
Deceased.

The administration of the estate of NANCY L. BLAIR a.k.a. NANCY LYNN BLAIR, deceased, whose date of death was August 12, 2012, is pending in the Circuit Court for SARASOTA County, Florida, Probate Division, the address of which is Post Office Box 3079, Sarasota, Florida 34230-3079. The names and addresses of the personal representative and the personal representative's attorney are set forth below.

All creditors of the decedent and other persons having claims or demands against decedent's estate on whom a copy of this notice is required to be served must file their claims with this court WITHIN THE LATER OF 3 MONTHS AFTER THE TIME OF THE FIRST PUBLICATION OF THIS NOTICE OR 30 DAYS AFTER THE DATE OF SERVICE OF A COPY OF THIS NOTICE ON THEM.

All other creditors of the decedent and other persons having claims or demands against decedent's estate must file their claims with this court WITHIN 3 MONTHS AFTER THE DATE OF THE FIRST PUBLICATION OF THIS NOTICE.

ALL CLAIMS NOT FILED WITHIN THE TIME PERIODS SET FORTH IN SECTION 733.702 OF THE FLORIDA PROBATE CODE WILL BE FOREVER BARRED.

NOTWITHSTANDING THE TIME PERIOD SET FORTH ABOVE, ANY CLAIM FILED TWO (2) YEARS OR MORE AFTER THE DECEDENT'S DATE OF DEATH IS BARRED.

The date of first publication of this notice is May 30, 2014.

Personal Representative:

ROBERT P. SCHEB
2750 Ringling Blvd., Suite 3
Sarasota, Florida 34237
Attorney for Personal Representative:
ROBERT P. SCHEB
E-Mail:
rscheb@bowmangeorge.com
Florida Bar No. 398519
BOWMAN, GEORGE, SCHEB,
KIMBROUGH & KOACH, P.A.
2750 Ringling Boulevard, Suite 3
Sarasota, Florida 34237
Telephone (941) 366-5510
May 30; June 6, 2014 14-02468S

FIRST INSERTION

NOTICE TO CREDITORS
IN THE CIRCUIT COURT FOR
SARASOTA COUNTY, FLORIDA
PROBATE DIVISION
File No. 2014 CP 2032 NC
IN RE: ESTATE OF
PATRICK J. MICHAELIS,
Deceased.

The administration of the estate of PATRICK J. MICHAELIS, deceased, whose date of death was April 15, 2014, is pending in the Circuit Court for Sarasota County, Florida, Probate Division, the address of which is 2000 Main Street, Sarasota, Florida 34237. The names and addresses of the personal representative and the personal representative's attorney are set forth below.

All creditors of the decedent and other persons having claims or demands against decedent's estate on whom a copy of this notice is required to be served must file their claims with this court ON OR BEFORE THE LATER OF 3 MONTHS AFTER THE TIME OF THE FIRST PUBLICATION OF THIS NOTICE OR 30 DAYS AFTER THE DATE OF SERVICE OF A COPY OF THIS NOTICE ON THEM.

All other creditors of the decedent and other persons having claims or demands against decedent's estate must file their claims with this court WITHIN 3 MONTHS AFTER THE DATE OF THE FIRST PUBLICATION OF THIS NOTICE.

ALL CLAIMS NOT FILED WITHIN THE TIME PERIODS SET FORTH IN SECTION 733.702 OF THE FLORIDA PROBATE CODE WILL BE FOREVER BARRED.

NOTWITHSTANDING THE TIME PERIOD SET FORTH ABOVE, ANY CLAIM FILED TWO (2) YEARS OR MORE AFTER THE DECEDENT'S DATE OF DEATH IS BARRED.

The date of first publication of this notice is May 30, 2014.

Personal Representative:

L. DADE LUNSFORD
584 A Dorseyville Road
Pittsburgh, PA 15238
Attorney for Personal Representative:
ELIZABETH C. MARSHALL
Florida Bar No. 0440884
Williams Parker Harrison
Dietz & Getzen
200 S. Orange Ave.
Sarasota, FL 34236
Telephone: 941-366-4800
Designation of Email Addresses for service:
Primary:
emarshall@williamsparker.com
Secondary:
kmartins@williamsparker.com
May 30; June 6, 2014 14-02458S

FIRST INSERTION

NOTICE TO CREDITORS
IN THE CIRCUIT COURT FOR
SARASOTA COUNTY, FLORIDA
PROBATE DIVISION
File Number 2014 CP 002034 NC
IN RE: ESTATE OF
LAWRENCE J. SCHOENBERG,
Deceased.

The administration of the ESTATE OF LAWRENCE J. SCHOENBERG, deceased, whose date of death was May 7, 2014, is pending in the Circuit Court for Sarasota County, Florida, Probate Division, the address of which is P.O. Box 3079, Sarasota, Florida 34230. The names and addresses of the personal representative and the personal representative's attorney are set forth below.

All creditors of the decedent and other persons having claims or demands against decedent's estate on whom a copy of this notice is required to be served must file their claims with this court WITHIN THE LATER OF 3 MONTHS AFTER THE TIME OF THE FIRST PUBLICATION OF THIS NOTICE OR 30 DAYS AFTER THE DATE OF SERVICE OF A COPY OF THIS NOTICE ON THEM.

All other creditors of the decedent and other persons having claims or demands against decedent's estate must file their claims with this court WITHIN 3 MONTHS AFTER THE DATE OF THE FIRST PUBLICATION OF THIS NOTICE.

ALL CLAIMS NOT FILED WITHIN THE TIME PERIODS SET FORTH IN SECTION 733.702 OF THE FLORIDA PROBATE CODE WILL BE FOREVER BARRED.

NOTWITHSTANDING THE TIME PERIODS SET FORTH ABOVE, ANY CLAIM FILED TWO (2) YEARS OR MORE AFTER THE DECEDENT'S DATE OF DEATH IS BARRED.

The date of the first publication of this Notice is May 30, 2014.

Personal Representative:

BARBARA BRIZDLE
c/o P.O. Box 3018
Sarasota, Florida 34230
Attorney for Personal Representative:
JAMES O. FERGESON, JR.
Florida Bar No. 171298
FERGESON, SKIPPER, SHAW,
KEYSER, BARON & TIRABASSI, P.A.
1515 Ringling Boulevard,
10th Floor
P. O. Box 3018
Sarasota, Florida 34230-3018
(941) 957-1900
jfergeson@fergesonskipper.com
services@fergesonskipper.com
3660204.27186
May 30; June 6, 2014 14-02469S



SAVE TIME

E-mail your
Legal Notice

legal@businessobserverfl.com

Sarasota County
Manatee County
Hillsborough County
Pinellas County
Pasco County
Lee County
Collier County
Charlotte County

**Wednesday
Noon Deadline
Friday
Publication**

**Business
Observer**

FIRST INSERTION

NOTICE OF SALE IN THE CIRCUIT COURT OF THE TWELFTH JUDICIAL CIRCUIT OF THE STATE OF FLORIDA, IN AND FOR SARASOTA COUNTY CIVIL DIVISION

CASE NO. 58-2012-CA-000005-0000-NC
CITIMORTGAGE, INC., Plaintiff, vs. STEVE O. GRAHAM A/K/A STEVEN O. GRAHAM; UNKNOWN SPOUSE OF STEVE O. GRAHAM A/K/A STEVEN O. GRAHAM; NADINE GRAHAM; IF LIVING, INCLUDING ANY UNKNOWN SPOUSE OF SAID DEFENDANT(S), IF REMARRIED, AND IF DECEASED, THE RESPECTIVE UNKNOWN HEIRS, DEVISEES, GRANTEEES, ASSIGNEES, CREDITORS, LIENORS, AND TRUSTEES, AND ALL OTHER PERSONS CLAIMING BY, THROUGH, UNDER OR AGAINST THE NAMED DEFENDANT(S); UNKNOWN TENANT #1; UNKNOWN TENANT #2; Defendant(s)

Notice is hereby given that, pursuant to a Final Summary Judgment of Foreclosure entered on 08/12/2013 in the above styled cause, in the Circuit Court of Sarasota County, Florida, the office of Karen E. Rushing clerk of the circuit court will sell the property situate in Sarasota County, Florida, described as:
 LOT 4, BLOCK 132, 8TH ADDITION TO PORT CHARLOTTE, ACCORDING TO THE PLAT THEREOF, AS RECORDED IN

PLAT BOOK 12, AT PAGES 20, 20-A THROUGH 20-Z-2, OF THE PUBLIC RECORDS OF SARASOTA COUNTY, FLORIDA.

at public sale, to the highest and best bidder, for cash, www.sarasota.realforeclose.com at 9:00 o'clock, A.M., on June 11, 2014

Any person claiming an interest in the surplus from the sale, if any, other than the property owner as of the date of the lis pendens, must file a claim within 60 days after the sale.

If you are a person with a disability who needs any accommodation in order to participate in this proceeding, you are entitled, at no cost to you, to the provision of certain assistance. Please contact the Sarasota County Jury Office, P.O. Box 3079, Sarasota, Florida 34230-3079, (941)861-7400, at least seven (7) days before your scheduled court appearance, or immediately upon receiving this notification if the time before the scheduled appearance is less than seven (7) days; if you are hearing or voice impaired, call 711.

ATTORNEY FOR PLAINTIFF
 By /S/ Josh D. Donnelly
 Josh D. Donnelly
 Florida Bar #64788

Date: 05/19/2014

THIS INSTRUMENT PREPARED BY:
 Law Offices Of Daniel C. Consuegra
 9204 King Palm Drive
 Tampa, FL 33619-1328
 Phone: 813-915-8660
 Attorneys for Plaintiff
 114784
 May 30; June 6, 2014 14-02344S

FIRST INSERTION

NOTICE OF FORECLOSURE SALE IN THE CIRCUIT COURT OF THE TWELFTH JUDICIAL CIRCUIT OF FLORIDA IN AND FOR SARASOTA COUNTY GENERAL JURISDICTION DIVISION

CASE NO. 2009 ca 005113
JPMORGAN CHASE BANK, NATIONAL ASSOCIATION, Plaintiff, vs. LINDA KIRBY, et al., Defendants.

NOTICE IS HEREBY GIVEN pursuant to a Summary Final Judgment of Foreclosure entered May 14, 2013 in Civil Case No. 2009 ca 005113 of the Circuit Court of the TWELFTH Judicial Circuit in and for Sarasota County, Sarasota, Florida, wherein JPMORGAN CHASE BANK, NATIONAL ASSOCIATION is Plaintiff and LINDA KIRBY, LINDA L. KIRBY, MORTGAGE ELECTRONIC REGISTRATION SYSTEMS INC., AS NOMINEE FOR SUNTRUST MORTGAGE, INC., UNKNOWN TENANT IN POSSESSION 1, UNKNOWN TENANT IN POSSESSION 2, UNKNOWN SPOUSE OF LINDA L. KIRBY, are Defendants, the Clerk of Court will sell to the highest and best bidder for cash electronically at www.sarasota.realforeclose.com in accordance with Chapter 45, Florida Statutes on the 18th day of June, 2014 at 09:00 AM on the following described property as set forth in said Summary Final Judgment, to-wit:
 Lot 13, High Point Circle, according to the Map or Plat thereof as recorded in Plat Book 4, Page 10, of the Public Records of Sarasota County, Florida.

Any person claiming an interest in the surplus from the sale, if any, other than the property owner as of the date of the lis pendens, must file a claim within 60 days after the sale.

If you are a person with a disability who needs any accommodation in order to participate in this proceeding, you are entitled, at no cost to you, to the provision of certain assistance. Please contact the Sarasota County Jury Office, P.O. Box 3079, Sarasota, Florida 34230-3079, (941)861-7400, at least seven (7) days before your scheduled court appearance, or immediately upon receiving this notification if the time before the scheduled appearance is less than seven (7) days; if you are hearing or voice impaired, call 711.

Heidi Sasha Kirlow, ES
 FLA.BAR #56397
 Brian Hummel, Esq.
 Fla. Bar No.: 46162

McCalla Raymer, LLC
 Attorney for Plaintiff
 225 E. Robinson St. Suite 660
 Orlando, FL 32801
 Phone: (407) 674-1850
 Fax: (321) 248-0420
 Email: MRService@mccallarayer.com
 2861533
 11-06278-5
 May 30; June 6, 2014 14-02352S

FIRST INSERTION

NOTICE OF SALE IN THE CIRCUIT COURT OF THE TWELFTH JUDICIAL CIRCUIT IN AND FOR SARASOTA COUNTY, FLORIDA, CIVIL ACTION

CASE NO.: 2012 CA 007288 NC
FIFTH THIRD BANK, AN OHIO BANKING CORPORATION, SUCCESSOR BY MERGER WITH FIFTH THIRD BANK, A MICHIGAN BANKING CORPORATION, SUCCESSOR BY MERGER WITH FIRST NATIONAL BANK OF FLORIDA, Plaintiff vs. A FIVE STAR BUSINESS, INC., et al.

Defendant(s)
 Notice is hereby given that, pursuant to a Final Judgment of Foreclosure dated April 7, 2014, entered in Civil Case Number 2012 CA 007288 NC, in the Circuit Court for Sarasota County, Florida, wherein FIFTH THIRD BANK, AN OHIO BANKING CORPORATION, SUCCESSOR BY MERGER WITH FIFTH THIRD BANK, A MICHIGAN BANKING CORPORATION, SUCCESSOR BY MERGER WITH FIRST NATIONAL BANK OF FLORIDA is the Plaintiff, and A FIVE STAR BUSINESS, INC., et al., are the Defendants, Sarasota County Clerk of Court will sell the property situated in Sarasota County, Florida, described as:

LOT 8, BLOCK 2759, OF 55TH ADDITION TO PORT CHARLOTTE SUBDIVISION, ACCORDING TO THE PLAT THEREOF RECORDED IN PLAT BOOK 22, PAGE 40, 40A THROUGH 40E, OF THE PUBLIC RECORDS OF SARASOTA COUNTY, FLORIDA.

at public sale, to the highest and best bidder, for cash, at www.sarasota.realforeclose.com at 09:00 AM, on the 3rd day of July, 2014. Any person claiming an interest in the surplus from the sale, if any, other than the property owner as of the date of the lis pendens must file a claim within 60 days after the sale.

If you are a person with a disability who needs any accommodation in order to participate in this proceeding, you are entitled, at no cost to you, to the provision of certain assistance. Please contact the Sarasota County Jury Office, P.O. Box 3079, Sarasota, Florida 34230-3079, (941)861-7400, at least seven (7) days before your scheduled court appearance, or immediately upon receiving this notification if the time before the scheduled appearance is less than seven (7) days; if you are hearing or voice impaired, call 711.

Dated: May 20, 2014
 By: /S/ Erik T. Silevitch
 Erik T. Silevitch, Esquire (FBN 92048)
 FLORIDA FORECLOSURE ATTORNEYS, PLLC
 4855 Technology Way, Suite 500
 Boca Raton, FL 33431
 (727) 446-4826
 emailservice@ffapllc.com
 Our File No: CA12-01439 /CQ
 May 30; June 6, 2014 14-02348S

FIRST INSERTION

NOTICE OF SALE IN THE CIRCUIT CIVIL COURT OF THE TWELFTH JUDICIAL CIRCUIT OF FLORIDA, IN AND FOR SARASOTA COUNTY CIVIL DIVISION

Case No. 58-2010-CA-005088 NC
Division C
WELLS FARGO BANK, N.A., Plaintiff, vs. PEDRO LAREDO AND MARGARITA LAREDO, ADMIRALS WALK CONDOMINIUM ASSOCIATION, INC., AND UNKNOWN TENANTS/OWNERS, Defendants.

Notice is hereby given, pursuant to Final Judgment of Foreclosure for Plaintiff entered in this cause on May 12, 2014, in the Circuit Court of Sarasota County, Florida, The Clerk of the Court will sell the property situated in Sarasota County, Florida described as:

CONDOMINIUM UNIT 103, BUILDING 3, ADMIRALS WALK, A CONDOMINIUM, TOGETHER WITH AN UNDIVIDED INTERESTS IN THE COMMON ELEMENTS, ACCORDING TO THE DECLARATION OF CONDOMINIUM THEREOF RECORDED IN INSTRUMENT NUMBER 2005102528, AS AMENDED FROM TIME TO TIME, OF THE PUBLIC RECORDS OF SARASOTA COUNTY, FLORIDA.

and commonly known as: 5701 SOLDIER CIR 3-103, SARASOTA, FL 34233; including the building, appurtenances, and fixtures located therein, at public sale, to the highest and best bidder, for cash, Sales are held online at: https://www.sarasota.realforeclose.com, on June 17, 2014 at 9:00 A.M.

Any persons claiming an interest in the surplus from the sale, if any, other than the property owner as of the date of the lis pendens must file a claim within 60 days after the sale.

If you are a person with a disability who needs any accommodation in order to participate in this proceeding, you are entitled, at no cost to you, to the provision of certain assistance. Please contact the Sarasota County Jury Office, P.O. Box 3079, Sarasota, Florida 34230-3079, (941)861-7400, at least seven (7) days before your scheduled court appearance, or immediately upon receiving this notification if the time before the scheduled appearance is less than seven (7) days; if you are hearing or voice impaired, call 711.

Karen E. Rushing
 By: Frances Grace Cooper, Esquire
 Attorney for Plaintiff
 Edward B. Pritchard
 (813) 229-0900 x1309
 Kass Shuler, P.A.
 P.O. Box 800
 Tampa, FL 33601-0800
 ForeclosureService@kasslaw.com
 309150/1005239/jlh
 May 30; June 6, 2014 14-02370S

FIRST INSERTION

RE-NOTICE OF FORECLOSURE SALE IN THE CIRCUIT COURT OF THE 12TH JUDICIAL CIRCUIT, IN AND FOR SARASOTA COUNTY, FLORIDA

CIVIL DIVISION: CASE NO.: 2008-CA-013070 SC
AURORA LOAN SERVICES, LLC, Plaintiff, vs. CLEOFE L PEARCY; ALBERT SALMON; JOHN DOE; JANE DOE AS UNKNOWN TENANT(S) IN POSSESSION OF THE SUBJECT PROPERTY, Defendants.

NOTICE IS HEREBY GIVEN pursuant to an Order Resetting Foreclosure Sale dated the 14th day of May, 2014, and entered in Case No. 2008-CA-013070 SC, of the Circuit Court of the 12TH Judicial Circuit in and for Sarasota County, Florida, wherein AURORA LOAN SERVICES, LLC is the Plaintiff and CLEOFE L PEARCY; ALBERT SALMON and UNKNOWN TENANT(S) IN POSSESSION OF THE SUBJECT PROPERTY are defendants. The Clerk of this Court shall sell to the highest and best bidder for cash electronically at www.sarasota.realforeclose.com at 9:00 AM on the 18th day of June, 2014, the following described property as set forth in said Final Judgment, to wit:

LOT 26, BLOCK 178, 2ND ADDITION TO PORT CHARLOTTE SUBDIVISION, A SUBDIVISION ACCORDING TO THE PLAT THEREOF AS RECORDED IN PLAT BOOK 11, AT PAGES 30, 30A THROUGH 30G, OF THE PUBLIC RECORDS OF SARASOTA COUNTY, FLORIDA.

ANY PERSON CLAIMING AN INTEREST IN THE SURPLUS FROM THE SALE, IF ANY, OTHER THAN THE PROPERTY OWNER AS OF THE DATE OF THE LIS PENDENS MUST FILE A CLAIM WITHIN 60 DAYS AFTER THE SALE.

If you are a person with a disability who needs any accommodation in order to participate in this proceeding, you are entitled, at no cost to you, to the provision of certain assistance. Please contact the Sarasota County Jury Office, P.O. Box 3079, Sarasota, Florida 34230-3079, (941)861-7400, at least seven (7) days before your scheduled court appearance, or immediately upon receiving this notification if the time before the scheduled appearance is less than seven (7) days; if you are hearing or voice impaired, call 711.

Dated this 21 day of May, 2014.
 By: Jennifer Nicole Tarquinio
 Bar #99192

Choice Legal Group, P.A.
 P.O. Box 9908
 Fort Lauderdale, FL 33310-0908
 Telephone: (954) 453-0365
 Facsimile: (954) 771-6052
 Toll Free: 1-800-441-2438
 DESIGNATED PRIMARY E-MAIL FOR SERVICE PURSUANT TO FLA R. JUD. ADMIN 2.516
 eservice@clegalgroup.com
 808-37429
 May 30; June 6, 2014 14-02369S

FIRST INSERTION

NOTICE OF SALE IN THE CIRCUIT COURT OF THE TWELFTH JUDICIAL CIRCUIT OF THE STATE OF FLORIDA, IN AND FOR SARASOTA COUNTY CIVIL DIVISION

CASE NO. 58-2009-CA-011226-XXXX-NC

BANK OF AMERICA, N.A., SUCCESSOR BY MERGER TO COUNTRYWIDE BANK, FSB, Plaintiff, vs. TERRY A. PURDY A/K/A TERRY PURDY SR.; UNKNOWN SPOUSE OF TERRY A. PURDY A/K/A TERRY PURDY SR.; IF LIVING, INCLUDING ANY UNKNOWN SPOUSE OF SAID DEFENDANT(S), IF REMARRIED, AND IF DECEASED, THE RESPECTIVE UNKNOWN HEIRS, DEVISEES, GRANTEEES, ASSIGNEES, CREDITORS, LIENORS, AND TRUSTEES, AND ALL OTHER PERSONS CLAIMING BY, THROUGH, UNDER OR AGAINST THE NAMED DEFENDANT(S); UNKNOWN TENANT #1; UNKNOWN TENANT #2; Defendant(s)

Notice is hereby given that, pursuant to a Final Summary Judgment of Foreclosure entered on 06/13/2013 in the above styled cause, in the Circuit Court of Sarasota County, Florida, the office of Karen E. Rushing clerk of the circuit court will sell the property situate in Sarasota County, Florida, described as:
 LOT 1, THE MISSION ESTATES, UNIT ONE, ACCORDING TO

THE PLAT THEREOF RECORDED IN PLAT BOOK 39, PAGE 6, OF THE PUBLIC RECORDS OF SARASOTA COUNTY, FLORIDA.

at public sale, to the highest and best bidder, for cash, www.sarasota.realforeclose.com at 9:00 o'clock, A.M., on June 11, 2014

Any person claiming an interest in the surplus from the sale, if any, other than the property owner as of the date of the lis pendens, must file a claim within 60 days after the sale.

If you are a person with a disability who needs any accommodation in order to participate in this proceeding, you are entitled, at no cost to you, to the provision of certain assistance. Please contact the Sarasota County Jury Office, P.O. Box 3079, Sarasota, Florida 34230-3079, (941)861-7400, at least seven (7) days before your scheduled court appearance, or immediately upon receiving this notification if the time before the scheduled appearance is less than seven (7) days; if you are hearing or voice impaired, call 711.

ATTORNEY FOR PLAINTIFF
 By /S/ Josh D. Donnelly
 Josh D. Donnelly
 Florida Bar #64788

Date: 05/19/2014

THIS INSTRUMENT PREPARED BY:
 Law Offices Of Daniel C. Consuegra
 9204 King Palm Drive
 Tampa, FL 33619-1328
 Phone: 813-915-8660
 Attorneys for Plaintiff
 44982
 May 30; June 6, 2014 14-02343S

FIRST INSERTION

NOTICE OF SALE IN THE CIRCUIT COURT OF THE TWELFTH JUDICIAL CIRCUIT OF THE STATE OF FLORIDA, IN AND FOR SARASOTA COUNTY CIVIL DIVISION

CASE NO. 58-2012-CA-004678-0000-NC

US BANK NATIONAL ASSOCIATION, AS TRUSTEE FOR CREDIT SUISSE FIRST BOSTON MORTGAGE SECURITIES CORP., HOME EQUITY ASSET TRUST 2006-4, HOME EQUITY PASS-THROUGH CERTIFICATES, SERIES 2006-4, Plaintiff, vs. FRED SANDERS JR.; UNKNOWN SPOUSE OF FRED SANDERS JR.; CINDY M. SANDERS; UNKNOWN SPOUSE OF CINDY M. SANDERS; IF LIVING, INCLUDING ANY UNKNOWN SPOUSE OF SAID DEFENDANT(S), IF REMARRIED, AND IF DECEASED, THE RESPECTIVE UNKNOWN HEIRS, DEVISEES, GRANTEEES, ASSIGNEES, CREDITORS, LIENORS, AND TRUSTEES, AND ALL OTHER PERSONS CLAIMING BY, THROUGH, UNDER OR AGAINST THE NAMED DEFENDANT(S); BRANCH BANKING AND TRUST COMPANY; KENSINGTON WOODS OWNERS ASSOCIATION, INC.; WHETHER DISSOLVED OR PRESENTLY EXISTING, TOGETHER WITH ANY GRANTEEES, ASSIGNEES, CREDITORS, LIENORS, OR TRUSTEES OF SAID DEFENDANT(S) AND ALL OTHER PERSONS CLAIMING BY, THROUGH, UNDER, OR AGAINST DEFENDANT(S); UNKNOWN TENANT #1; UNKNOWN TENANT #2;

at public sale, to the highest and best bidder, for cash, www.sarasota.realforeclose.com at 9:00 o'clock, A.M., on June 13, 2014

Any person claiming an interest in the surplus from the sale, if any, other than the property owner as of the date of the lis pendens, must file a claim within 60 days after the sale.

If you are a person with a disability who needs any accommodation in order to participate in this proceeding, you are entitled, at no cost to you, to the provision of certain assistance. Please contact the Sarasota County Jury Office, P.O. Box 3079, Sarasota, Florida 34230-3079, (941)861-7400, at least seven (7) days before your scheduled court appearance, or immediately upon receiving this notification if the time before the scheduled appearance is less than seven (7) days; if you are hearing or voice impaired, call 711.

ATTORNEY FOR PLAINTIFF
 By /S/ Josh D. Donnelly
 Josh D. Donnelly
 Florida Bar #64788

Date: 05/20/2014

THIS INSTRUMENT PREPARED BY:
 Law Offices Of Daniel C. Consuegra
 9204 King Palm Drive
 Tampa, FL 33619-1328
 Phone: 813-915-8660
 Attorneys for Plaintiff
 127089
 May 30; June 6, 2014 14-02347S

FIRST INSERTION

NOTICE OF SALE IN THE CIRCUIT COURT OF THE TWELFTH JUDICIAL CIRCUIT OF THE STATE OF FLORIDA, IN AND FOR

SARASOTA COUNTY CIVIL DIVISION CASE NO. 58-2012-CA-006403-0000-NC

FEDERAL NATIONAL MORTGAGE ASSOCIATION, Plaintiff, vs. EVELYN J. THOMPSON; UNKNOWN SPOUSE OF EVELYN J. THOMPSON; MATTHEW D. THOMPSON; UNKNOWN SPOUSE OF MATTHEW D. THOMPSON; IF LIVING, INCLUDING ANY UNKNOWN SPOUSE OF SAID DEFENDANT(S), IF REMARRIED, AND IF DECEASED, THE RESPECTIVE UNKNOWN HEIRS, DEVISEES, GRANTEEES, ASSIGNEES, CREDITORS, LIENORS, AND TRUSTEES, AND ALL OTHER PERSONS CLAIMING BY, THROUGH, UNDER OR AGAINST THE NAMED DEFENDANT(S); MORTGAGE ELECTRONIC REGISTRATION SYSTEMS, INC. AS NOMINEE FOR QUICKEN LOANS, INC.; WHETHER DISSOLVED OR PRESENTLY EXISTING, TOGETHER WITH ANY GRANTEEES, ASSIGNEES, CREDITORS, LIENORS, OR TRUSTEES OF SAID DEFENDANT(S) AND ALL OTHER PERSONS CLAIMING BY, THROUGH, UNDER, OR AGAINST DEFENDANT(S); UNKNOWN TENANT #1; UNKNOWN TENANT #2; Defendant(s)

at public sale, to the highest and best bidder, for cash, www.sarasota.realforeclose.com at 9:00 o'clock, A.M., on June 11, 2014

Any person claiming an interest in the surplus from the sale, if any, other than the property owner as of the date of the lis pendens, must file a claim within 60 days after the sale.

If you are a person with a disability who needs any accommodation in order to participate in this proceeding, you are entitled, at no cost to you, to the provision of certain assistance. Please contact the Sarasota County Jury Office, P.O. Box 3079, Sarasota, Florida 34230-3079, (941)861-7400, at least seven (7) days before your scheduled court appearance, or immediately upon receiving this notification if the time before the scheduled appearance is less than seven (7) days; if you are hearing or voice impaired, call 711.

ATTORNEY FOR PLAINTIFF
 By /S/ Josh D. Donnelly
 Josh D. Donnelly
 Florida Bar #64788

Date: 05/19/2014

THIS INSTRUMENT PREPARED BY:
 Law Offices Of Daniel C. Consuegra
 9204 King Palm Drive
 Tampa, FL 33619-1328
 Phone: 813-915-8660
 Attorneys for Plaintiff
 127848
 May 30; June 6, 2014 14-02345S

FIRST INSERTION

NOTICE OF SALE IN THE CIRCUIT COURT OF THE TWELFTH JUDICIAL CIRCUIT OF THE STATE OF FLORIDA, IN AND FOR SARASOTA COUNTY CIVIL DIVISION

CASE NO. 58-2013-CA-000438-XXXX-NC

FEDERAL NATIONAL MORTGAGE ASSOCIATION, Plaintiff, vs. LAURENT P. LELARGUE; UNKNOWN SPOUSE OF LAURENT P. LELARGUE; IF LIVING, INCLUDING ANY UNKNOWN SPOUSE OF SAID DEFENDANT(S), IF REMARRIED, AND IF DECEASED, THE RESPECTIVE UNKNOWN HEIRS, DEVISEES, GRANTEEES, ASSIGNEES, CREDITORS, LIENORS, AND TRUSTEES, AND ALL OTHER PERSONS CLAIMING BY, THROUGH, UNDER, OR AGAINST DEFENDANT(S); UNKNOWN TENANT #1; UNKNOWN TENANT #2; Defendant(s)

Notice is hereby given that, pursuant to a Final Summary Judgment of Foreclosure entered on 02/11/2014 in the above-styled cause, in the Circuit Court of Sarasota County, Florida, the office of Karen E. Rushing clerk of the circuit court will sell the property situate in

Sarasota County, Florida, described as: Condominium Unit No. 2721-C, HIDDEN LAKE VILLAGE CONDOMINIUM, according to the Declaration thereof, as recorded in Official Records Book 1368, Pages 1482 through 1546, inclusive, and Condominium Plat Book 14, Pages 16A through 16H, inclusive, both of the Public Records of Sarasota County, Florida.

at public sale, to the highest and best bidder, for cash, www.sarasota.realforeclose.com at 9:00 o'clock, A.M., on June 11, 2014

Any person claiming an interest in the surplus from the sale, if any, other than the property owner as of the date of the lis pendens, must file a claim within 60 days after the sale.

If you are a person with a disability who needs any accommodation in order to participate in this proceeding, you are entitled, at no cost to you, to the provision of certain assistance. Please contact the Sarasota County Jury Office, P.O. Box 3079, Sarasota, Florida 34230-3079, (941)861-7400, at least seven (7) days before your scheduled court appearance, or immediately upon receiving this notification if the time before the scheduled appearance is less than seven (7) days; if you are hearing or voice impaired, call 711.

ATTORNEY FOR PLAINTIFF
 By /S/ Josh D. Donnelly
 Josh D. Donnelly
 Florida Bar #64788

Date: 05/19/2014

THIS INSTRUMENT PREPARED BY:
 Law Offices Of Daniel C. Consuegra
 9204 King Palm Drive
 Tampa, FL 33619-1328
 Phone: 813-915-8660
 Attorneys for Plaintiff
 142536
 May 30; June 6, 2014 14-02346S

HOW TO PUBLISH YOUR LEGAL NOTICE IN THE BUSINESS OBSERVER

FOR MORE INFORMATION, CALL:
 (813) 221-9505 Hillsborough, Pasco
 (727) 447-7784 Pinellas
 (941) 906-9386 Manatee, Sarasota, Lee
 Or e-mail: legal@businessobserverfl.com

(239) 263-0122 Collier
 (407) 654-5500 Orange
 (941) 249-4900 Charlotte

FIRST INSERTION

NOTICE OF FORECLOSURE SALE IN THE CIRCUIT COURT OF THE 12TH JUDICIAL CIRCUIT, IN AND FOR SARASOTA COUNTY, FLORIDA.

CASE NO. 2008 CA 010752
THE BANK OF NEW YORK, AS TRUSTEE FOR THE BENEFIT OF THE CERTIFICATE HOLDERS, CWABS, INC., INC. ASSET BACKED CERTIFICATE, SERIES 2007-2

Plaintiff, vs. IRENE GREEN, et al., Defendants.
 NOTICE IS HEREBY GIVEN pursuant to an Order or Final Judgment entered in Case No. 2008 CA 010752 of the Circuit Court of the 12TH Judicial Circuit in and for SARASOTA County, Florida, wherein, THE BANK OF NEW YORK, AS TRUSTEE FOR THE BENEFIT OF THE CERTIFICATE HOLDERS, CWABS, INC., INC. ASSET BACKED CERTIFICATE, SERIES 2007-2, Plaintiff, and IRENE GREEN, et al., are Defendants, the Clerk of Court will sell to the highest bidder for cash at, FORECLOSURE SALE TO BE CONDUCTED VIA THE INTERNET: WWW.SARASOTA.REALFORECLOSE.COM, at the hour of 9:00 A.M., on the 13th day of June, 2014, the following described property:
 LOT 12, BLOCK 11, FIRST ADDITION TO NEWTON, TOGETHER WITH 1/2 OF THE VACATED ALLEY ADJACENT TO THE NORTH LOT LINE, ACCORDING TO THE PLAT THEREOF RECORDED IN PLAT BOOK 2, PAGE 16, OF

THE PUBLIC RECORDS OF SARASOTA COUNTY, FLORIDA.
 PROPERTY ADDRESS: 1667 24TH STREET, SARASOTA, FL 34234

Any person claiming an interest in the surplus from the sale, if any, other than the property owner as of the date of the lis pendens must file a claim within 60 days after the sale.

If you are a person with a disability who needs any accommodation in order to participate in this proceeding, you are entitled, at no cost to you, to the provision of certain assistance. Please contact the Sarasota County Jury Office, P.O. Box 3079, Sarasota, Florida 34230-3079, (941)861-7400, at least seven (7) days before your scheduled court appearance, or immediately upon receiving this notification if the time before the scheduled appearance is less than seven (7) days; if you are hearing or voice impaired, call 711.

DATED this 20 day of May 2014.

By: Shannon Jones, Esq.
 Florida Bar No. 106419

GREENSPOON MARDER, P.A.
 TRADE CENTRE SOUTH,
 SUITE 700
 100 WEST CYPRESS CREEK ROAD
 FORT LAUDERDALE, FL 33309
 Telephone: (954) 343 6273
 Hearing Line: (888) 491-1120
 Facsimile: (954) 343 6982
 Email 1:
 shannon.jones@gmlaw.com
 Email 2: gmforeclosure@gmlaw.com
 (29152.0399/ASaavedra)
 May 30; June 6, 2014 14-02349S

FIRST INSERTION

NOTICE OF SALE IN THE CIRCUIT COURT OF THE TWELFTH JUDICIAL CIRCUIT IN AND FOR SARASOTA COUNTY, FLORIDA

Case No.: 58-2012-CA-002969 NC
BANK OF AMERICA, N.A.

Plaintiff, v. ANA C FERNANDEZ; ANY AND ALL UNKNOWN PARTIES CLAIMING BY, THROUGH, UNDER, AND AGAINST THE HEREIN NAMED INDIVIDUAL DEFENDANT(S) WHO ARE NOT KNOWN TO BE DEAD OR ALIVE, WHETHER SAID UNKNOWN PARTIES MAY CLAIM AN INTEREST AS SPOUSES, HEIRS, DEVISEES, GRANTEEES, OR OTHER CLAIMANTS; STONERIDGE CONDOMINIUM ASSOCIATION, INC.

Defendant(s).
 NOTICE IS HEREBY GIVEN pursuant to an Order of Uniform Final Judgment of Foreclosure dated February 24, 2014, entered in Civil Case No. 58-2012-CA-002969 NC of the Circuit Court of the Twelfth Judicial Circuit in and for Sarasota County, Florida, wherein the Clerk of the Circuit Court will sell to the highest bidder for cash on the 24th day of June, 2014, at 9:00 a.m. online at the website: <https://www.sarasota.realforeclose.com>, relative to the following described property as set forth in the Final Judgment, to wit:

CONDOMINIUM UNIT NO. 8-202. STONERIDGE, A CONDOMINIUM, ACCORDING TO THE DECLARATION OF CONDOMINIUM THEREOF, AS

RECORDED IN INSTRUMENT NUMBER 2005158106, AND ANY AMENDMENTS THERETO, OF THE PUBLIC RECORDS OF SARASOTA COUNTY, FLORIDA, TOGETHER WITH AND UNDIVIDED INTEREST IN THE COMMON ELEMENT APPURTENANT THERETO.

Any person claiming an interest in the surplus from the sale, if any, other than the property owner as of the date of the Lis Pendens must file a claim within 60 days after the sale.

If you are a person with a disability who needs any accommodation in order to participate in this proceeding, you are entitled, at no cost to you, to the provision of certain assistance. Please contact the Sarasota County Jury Office, P.O. Box 3079, Sarasota, Florida 34230-3079, (941)861-7400, at least seven (7) days before your scheduled court appearance, or immediately upon receiving this notification if the time before the scheduled appearance is less than seven (7) days; if you are hearing or voice impaired, call 711.

MORRIS/HARDWICK|SCHNEIDER, LLC
 By: Susan Sparks, Esq.,
 FBN: 33626
 9409 Philadelphia Road
 Baltimore, Maryland 21237

Mailing Address:
 Morris|Hardwick|Schneider, LLC
 5110 Eisenhower Blvd., Suite 302A
 Tampa, Florida 33634
 Toll Free: (866)-503-4930
 MHSinbox@closingsource.net
 FL-9701196-11
 10828591
 May 30; June 6, 2014 14-02393S

FIRST INSERTION

NOTICE OF FORECLOSURE SALE IN THE CIRCUIT COURT OF THE 12TH JUDICIAL CIRCUIT, IN AND FOR SARASOTA COUNTY, FLORIDA

CIVIL DIVISION:
CASE NO.: 2010 CA 010330 NC

WELLS FARGO BANK, NA, Plaintiff, vs. RECHELLE GUDGEL; JEFFERSON CLUB CONDOMINIUM ASSOCIATION, INC.; UNKNOWN TENANT(S); IN POSSESSION OF THE SUBJECT PROPERTY, Defendants.

NOTICE IS HEREBY GIVEN pursuant to Final Judgment of Foreclosure dated the 16th day of May, 2014, and entered in Case No. 2010 CA 010330 NC, of the Circuit Court of the 12TH Judicial Circuit in and for Sarasota County, Florida, wherein WELLS FARGO BANK, NA is the Plaintiff and RECHELLE GUDGEL; JEFFERSON CLUB CONDOMINIUM ASSOCIATION, INC. and UNKNOWN TENANT(S) IN POSSESSION OF THE SUBJECT PROPERTY are defendants. The Clerk of this Court shall sell to the highest and best bidder for cash electronically at www.sarasota.realforeclose.com at 9:00 AM on the 18th day of June, 2014, the following described property as set forth in said Final Judgment, to wit:

UNIT 5-F, JEFFERSON CLUB, A CONDOMINIUM ACCORDING TO THE DECLARATION OF CONDOMINIUM RECORDED IN OFFICIAL RECORDS BOOK 1325, PAGES 1840 THROUGH 1884, INCLUSIVE, AND ALL

AMENDMENTS THERETO, AND AS PER PLAT THEREOF RECORDED IN CONDOMINIUM BOOK 13, PAGES 7 AND 7A, OF THE PUBLIC RECORDS OF SARASOTA COUNTY, FLORIDA.

ANY PERSON CLAIMING AN INTEREST IN THE SURPLUS FROM THE SALE, IF ANY, OTHER THAN THE PROPERTY OWNER AS OF THE DATE OF THE LIS PENDENS MUST FILE A CLAIM WITHIN 60 DAYS AFTER THE SALE.

If you are a person with a disability who needs any accommodation in order to participate in this proceeding, you are entitled, at no cost to you, to the provision of certain assistance. Please contact the Sarasota County Jury Office, P.O. Box 3079, Sarasota, Florida 34230-3079, (941)861-7400, at least seven (7) days before your scheduled court appearance, or immediately upon receiving this notification if the time before the scheduled appearance is less than seven (7) days; if you are hearing or voice impaired, call 711.

Dated this 21 day of May, 2014.

By: Jennifer Nicole Tarquinio
 Bar #99192

Choice Legal Group, P.A.
 P.O. Box 9908
 Fort Lauderdale, FL 33310-0908
 Telephone: (954) 453-0365
 Facsimile: (954) 771-6052
 Toll Free: 1-800-441-2438
 DESIGNATED PRIMARY E-MAIL FOR SERVICE PURSUANT TO FLA R. JUD. ADMIN 2.516
 eservice@clelegalgroup.com
 10-29530
 May 30; June 6, 2014 14-02368S

FIRST INSERTION

NOTICE OF FORECLOSURE SALE IN THE CIRCUIT COURT OF THE TWELFTH JUDICIAL CIRCUIT IN AND FOR SARASOTA COUNTY, FLORIDA

GENERAL JURISDICTION DIVISION

Case No. 2011 CA 001015 NC

Newbury Place REO IV, LLC, Plaintiff, vs. Joseph Jorame AKA Jormane Joseph ; et al., Defendants.

NOTICE IS HEREBY GIVEN pursuant to a Final Judgment of Foreclosure dated March 14, 2014, entered in Case No. 2011 CA 001015 NC of the Circuit Court of the Twelfth Judicial Circuit, in and for Sarasota County, Florida, wherein Newbury Place REO IV, LLC is the Plaintiff and Joseph Jorame AKA Jormane Joseph ; The Unknown Spouse of Joseph Jorame AKA Jormane Joseph; Rose Marie Lubin AKA Rosemarie Lubin; The Unknown Spouse of Rose Marie Lubin AKA Rosemarie Lubin; Any And All Unknown Parties Claiming By, Through, Under And Against The Herein Named Individual Defendant(S) Who Are Not Known To Be Dead Or Alive, Whether Said Unknown Parties May Claim An Interest As Spouses, Heirs, Devisees, Grantees Or Other Claimants; Tenant #1; Tenant #2; Tenant #3; Tenant #4; the names being fictitious to account for parties in possession are the Defendants, that the Clerk of Courts will sell to the highest and best bidder for cash by electronic sale at www.sarasota.realforeclose.com, beginning at 9:00 AM on the 12th day of June, 2014, the following described property as set forth in said Final Judgment, to wit:

LOT 39, BLOCK 465, 8th ADDITION TO PORT CHARLOTTE SUBDIVISION, ACCORDING TO THE PLAT THEREOF, AS RECORDED IN PLAT BOOK 12, PAGES 20 AND 20A THRU 20K, OF THE PUBLIC RECORDS OF SARASOTA COUNTY, FLORIDA.

Any person claiming an interest in the surplus from the sale, if any, other than the property owner as of the date of the lis pendens must file a claim within 60 days after the sale.

If you are a person with a disability who needs any accommodation in order to participate in this proceeding, you are entitled, at no cost to you, to the provision of certain assistance. Please contact the Sarasota County Jury Office, P.O. Box 3079, Sarasota, Florida 34230-3079, (941)861-7400, at least seven (7) days before your scheduled court appearance, or immediately upon receiving this notification if the time before the scheduled appearance is less than seven (7) days; if you are hearing or voice impaired, call 711.

By Marta Cedenno, Esq.
 Florida Bar No. 694754

BROCK & SCOTT, PLLC
 Attorney for Plaintiff
 1501 N.W. 49th Street, Suite 200
 Ft. Lauderdale, FL 33309
 Phone: (954) 618-6955, ext. 6108
 Fax: (954) 618-6954
 FLCourtDocs@brockandscott.com
 File # 12-F04831
 May 30; June 6, 2014 14-02376S

FIRST INSERTION

NOTICE OF FORECLOSURE SALE IN THE CIRCUIT COURT OF THE TWELFTH JUDICIAL CIRCUIT IN AND FOR

SARASOTA COUNTY, FLORIDA
CASE NO.: 2014 CA 000156 NC

FEDERAL NATIONAL MORTGAGE ASSOCIATION ("FANNIE MAE"), A CORPORATION ORGANIZED AND EXISTING UNDER THE LAWS OF THE UNITED STATES OF AMERICA, Plaintiff, vs. IRA C. DAWSON; UNKNOWN SPOUSE OF IRA C. DAWSON; SOUTH VENICE CIVIC ASSOCIATION, INC.; UNKNOWN TENANT(S) IN POSSESSION #1 and #2, and ALL OTHER UNKNOWN PARTIES, et al., Defendant(s).

NOTICE IS HEREBY GIVEN pursuant to a Final Summary Judgment of Foreclosure dated May 12, 2014, entered in Civil Case No.: 2014 CA 000156 NC of the Circuit Court of the Twelfth Judicial Circuit in and for Sarasota County, Florida, wherein FEDERAL NATIONAL MORTGAGE ASSOCIATION ("FANNIE MAE"), A CORPORATION ORGANIZED AND EXISTING UNDER THE LAWS OF THE UNITED STATES OF AMERICA, Plaintiff, and IRA C. DAWSON; SOUTH VENICE CIVIC ASSOCIATION, INC., are Defendants.

KAREN E. RUSHING, The Clerk of the Circuit Court, will sell to the highest bidder for cash, www.sarasota.realforeclose.com, at 09:00 AM, on the 17th day of June, 2014, the following described real property as set forth in said Final Summary Judgment, to wit:

LOTS 12488, 12489, 12490, 12491 AND 12492, SOUTH VENICE, UNIT 48, ACCORDING TO THE PLAT THEREOF, AS RECORDED IN PLAT BOOK 7, PAGE 12, OF THE PUBLIC RECORDS OF SARASOTA COUNTY, FLORIDA.

FIRST INSERTION

NOTICE OF FORECLOSURE SALE IN THE CIRCUIT COURT OF THE 12th JUDICIAL CIRCUIT IN AND FOR SARASOTA COUNTY, FLORIDA

CASE NO.: 2013-CA-007483 NC

Div. A

WELLS FARGO BANK, N.A. Plaintiff, vs. DARREN BRITT, GREYSTONE OWNERS' ASSOCIATION, INC., EQUABLE ASCENT FINANCIAL LLC, Defendants.

NOTICE IS HEREBY GIVEN pursuant to a Summary Final Judgment of Foreclosure dated May 20, 2014, and entered in Case No. 2013-CA-007483 NC Div. A of the Circuit Court of the 12th Judicial Circuit, in and for SARASOTA County, Florida, where WELLS FARGO BANK, N.A., is the Plaintiff and DARREN BRITT, GREYSTONE OWNERS' ASSOCIATION, INC., EQUABLE ASCENT FINANCIAL LLC, are the Defendants, the Clerk of Court shall offer for sale to the highest bidder for cash on September 17, 2014, beginning at 9:00 A.M., at www.sarasota.realforeclose.com, the following described property as set forth in said Summary Final Judgment lying and being situate in SARASOTA County, Florida, to wit:

Lot 5, GREYSTONE, according to the plat thereof, as recorded in Plat Book 32, Page 21 through 21D, of the Public Records of Sarasota County, Florida.

ANY PERSON CLAIMING AN INTEREST IN THE SURPLUS FROM THE SALE, IF ANY, OTHER THAN THE PROPERTY OWNER AS OF THE DATE OF THE LIS PENDENS MUST FILE A CLAIM WITHIN 60 DAYS AFTER THE SALE. THE CLERK SHALL RECEIVE A SERVICE CHARGE OF UP TO \$70 FOR SERVICES IN MAKING, RECORDING, AND CERTIFYING THE SALE AND TITLE THAT SHALL BE ASSESSED AS COSTS. THE COURT, IN ITS DISCRETION, MAY ENLARGE THE TIME OF THE SALE. NOTICE OF THE CHANGED TIME OF SALE SHALL BE PUBLISHED AS PROVIDED HEREIN.

If you are a person with a disability who needs any accommodation in order to participate in this proceeding, you are entitled, at no cost to you, to the provision of certain assistance. Please contact the Sarasota County Jury Office, P.O. Box 3079, Sarasota, Florida 34230-3079, (941)861-7400, at least seven (7) days before your scheduled court appearance, or immediately upon receiving this notification if the time before the scheduled appearance is less than seven (7) days; if you are hearing or voice impaired, call 711.

DATED this 21st day of May, 2014.

By: /s/ Arnold M. Straus, Jr. Esq.
 Arnold M. Straus, Jr. Esq.
 Fla Bar # 275328

STRAUS & EISLER, P.A.
 Attorneys for Plaintiff
 10081 Pines Blvd., Suite C
 Pembroke Pines, FL 33024
 954-431-2000
 Service.pines@strauselers.com
 May 30; June 6, 2014 14-02356S

FIRST INSERTION

NOTICE OF SALE PURSUANT TO CHAPTER 45 IN THE CIRCUIT COURT OF THE TWELFTH JUDICIAL CIRCUIT IN AND FOR SARASOTA COUNTY, FLORIDA

CIVIL ACTION
CASE NO.: 2010 CA 002103 NC

DIVISION: A
PNC MORTGAGE, A DIVISION OF PNC BANK, NATIONAL ASSOCIATION, Plaintiff, vs. CALDWELL, JOHN et al, Defendant(s).

NOTICE IS HEREBY GIVEN Pursuant to a Final Judgment of Foreclosure dated May 6, 2014, and entered in Case No. 2010 CA 002103 NC of the Circuit Court of the Twelfth Judicial Circuit in and for Sarasota County, Florida in which PNC Mortgage, A Division of PNC Bank, National Association, is the Plaintiff and John Caldwell, PNC Bank, N.A. Successor By Merger To National City Bank, Susan Caldwell a/k/a Sue Caldwell, are defendants, the Sarasota County Clerk of the Circuit Court will sell to the highest and best bidder for cash in/on the Internet: www.sarasota.realforeclose.com, Sarasota County, Florida at 9:00am on the 16th day of June, 2014, the following described property as set forth in said Final Judgment of Foreclosure:

A PARCEL OF LAND LOCATED IN A PART OF THE SOUTHWEST QUARTER OF SECTION 3, TOWNSHIP 38 SOUTH, RANGE 18 EAST, SARASOTA COUNTY, FLORIDA, WHICH IS MORE PARTICULARLY DESCRIBED AS FOLLOWS:

COMMENCING AT THE NORTHEAST CORNER OF SOUTHEAST QUARTER OF THE NORTHEAST QUARTER OF SECTION 3; THENCE WEST ALONG THE NORTH LINE OF SAID SOUTHEAST QUARTER, NORTHEAST QUARTER, SOUTHWEST QUARTER, A DISTANCE OF 421.46 FEET TO THE POINT OF BEGINNING; THENCE SOUTH 01 DEGREES, 29 MINUTES, 24 SECONDS EAST, 49.53 FEET; THENCE SOUTH 67 DEGREES, 07 MINUTES, 08 SECONDS WEST, 155.84 FEET; THENCE NORTH 01 DEGREES, 33 MINUTES, 37 SECONDS WEST, A DISTANCE OF 106.19 FEET TO THE NORTH LINE OF SAID SOUTHEAST QUARTER, NORTHEAST QUARTER OF THE SOUTHWEST QUARTER; THENCE NORTH 88 DEGREES, 26 MINUTES, 23 SECONDS EAST, 145.24 FEET TO THE POINT OF BEGINNING.

A PERPETUAL RIGHT OF WAY

30 FEET WIDE LYING IN THE NORTHEAST QUARTER OF THE SOUTHWEST QUARTER OF SECTION 3, TOWNSHIP 38 SOUTH, RANGE 18 EAST, MORE PARTICULARLY DESCRIBED AS FOLLOWS:

COMMENCE AT THE NORTHEAST CORNER OF THE SOUTHWEST QUARTER OF SECTION 3; THENCE SOUTH 0 DEGREES, 38 MINUTES, 34 SECONDS EAST, 693.44 FEET TO THE NORTHEAST QUARTER OF THE SOUTHEAST QUARTER OF NORTHEAST QUARTER OF SOUTHWEST QUARTER OF SAID SECTION 3; THENCE CONTINUE SOUTH 0 DEGREES, 38 MINUTES, 29 SECONDS WEST, 23.89 FEET TO AN OLD CORNER FOR A POINT OF BEGINNING; THENCE SOUTH 88 DEGREES, 26 MINUTES, 29 SECONDS WEST, ALONG AN OLD MONUMENTED AND OCCUPIED LINE, 956.37 FEET TO EAST LINE OF PALMETTO AVENUE; THENCE NORTH 17 DEGREES, 28 MINUTES, 25 SECONDS WEST ALONG SAID EAST LINE OF PALMETTO AVENUE, 31.20 FEET; THENCE NORTH 88 DEGREES, 26 MINUTES, 29 SECONDS EAST, 965.40 FEET; THENCE SOUTH 0 DEGREES, 38 MINUTES 34 SECONDS EAST, 30.00 FEET TO THE POINT OF BEGINNING. LESS RIGHT OF WAY FOR TAMiami TRAIL (U.S. HIGHWAY NO. 41, STATE ROAD NO. 45).

A/K/A 121 SPANISH POINT DR., OSPREY, FL 34229

Any person claiming an interest in the surplus from the sale, if any, other than the property owner as of the date of the Lis Pendens must file a claim within 60 days after the sale.

If you are a person with a disability who needs any accommodation in order to participate in this proceeding, you are entitled, at no cost to you, to the provision of certain assistance. Please contact the Sarasota County Jury Office, P.O. Box 3079, Sarasota, Florida 34230-3079, (941)861-7400, at least seven (7) days before your scheduled court appearance, or immediately upon receiving this notification if the time before the scheduled appearance is less than seven (7) days; if you are hearing or voice impaired, call 711.

Albertelli Law
 Attorney for Plaintiff
 P.O. Box 23028
 Tampa, FL 33623
 (813) 221-4743
 (813) 221-9171 facsimile
 EService: servealaw@albertellilaw.com
 BM - 11-86847
 May 30; June 6, 2014 14-02373S

FIRST INSERTION

NOTICE OF FORECLOSURE SALE IN THE CIRCUIT COURT OF THE TWELFTH JUDICIAL CIRCUIT IN AND FOR

SARASOTA COUNTY, FLORIDA
CASE NO.: 2012 CA 008790 NC

THE BANK OF NEW YORK MELLON FKA THE BANK OF NEW YORK AS TRUSTEE FOR THE CERTIFICATEHOLDERS OF THE CWABS INC., ASSET-BACKED CERTIFICATES, SERIES 2005-14, Plaintiff, vs. BRIDGET L. JOHNSON; J. BRIAN JOHNSON; HOUSEHOLD FINANCE CORPORATION III; UNKNOWN TENANT(S) IN POSSESSION #1 and #2, and ALL OTHER UNKNOWN PARTIES, et al., Defendant(s).

NOTICE IS HEREBY GIVEN pursuant to a Final Summary Judgment of Foreclosure dated May 12, 2014, entered in Civil Case No.: 2012 CA 008790 NC of the Circuit Court of the Twelfth Judicial Circuit in and for Sarasota County, Florida, wherein THE BANK OF NEW YORK MELLON FKA THE BANK OF NEW YORK AS TRUSTEE FOR THE CERTIFICATEHOLDERS OF THE CWABS INC., ASSET-BACKED CERTIFICATES, SERIES 2005-14, Plaintiff, and BRIDGET L. JOHNSON; J. BRIAN JOHNSON; HOUSEHOLD FINANCE CORPORATION III; and ALL OTHER UNKNOWN PARTIES, including, if a named Defendant is deceased, the personal representatives, the surviving spouse, heirs, devisees, grantees, creditors, and all other parties claiming, by, through, under or against that Defendant, and all claimants, persons or parties, natural or corporate, or whose exact legal status is unknown, claiming under any of the above named or described Defendants, are Defendants.

KAREN E. RUSHING, The Clerk of the Circuit Court, will sell to the highest bidder for cash, www.sarasota.realforeclose.com, at 09:00 AM, on the 17th day of June, 2014, the following described real property as set forth in said Final Summary Judgment, to wit:

LOT 15 AND THE WEST 17 FEET OF LOT 16, BLOCK 223,

OF EDGEWOOD SECTION OF VENICE, ACCORDING TO THE PLAT THEREOF AS RECORDED IN PLAT BOOK 2, PAGE 166, OF THE PUBLIC RECORDS OF SARASOTA COUNTY, FLORIDA.

If you are a person claiming a right to funds remaining after the sale, you must file a claim with the clerk no later than 60 days after the sale. If you fail to file a claim you will not be entitled to any remaining funds. After 60 days, only the owner of record as of the date of the lis pendens may claim the surplus.

If you cannot afford an attorney, contact Gulfcoast Legal Services at (941)366-1746 or www.gulfcoastlegal.org, or Legal Aid of Manasota at (941) 366-0038 or www.legalaidofmanasota.org. If you do not qualify for free legal assistance or do not know an attorney, you may call an attorney referral service (listed in the phone book), or contact the Florida Bar Lawyer Referral Service at (800)342-8011.

IF YOU ARE A PERSON WITH A DISABILITY WHO NEEDS ANY ACCOMMODATION IN ORDER TO PARTICIPATE IN THIS PROCEEDING, YOU ARE ENTITLED, AT NO COST TO YOU, TO THE PROVISION OF CERTAIN ASSISTANCE. PLEASE CONTACT THE SARASOTA COUNTY JURY OFFICE, P.O. BOX 3079, SARASOTA, FLORIDA 34230-3079, (941)861-7400, AT LEAST SEVEN (7) DAYS BEFORE YOUR SCHEDULED COURT APPEARANCE, OR IMMEDIATELY UPON RECEIVING THIS NOTIFICATION IF THE TIME BEFORE THE SCHEDULED APPEARANCE IS LESS THAN SEVEN (7) DAYS; IF YOU ARE HEARING OR VOICE IMPAIRED, CALL 711.

Dated: 5/20/14

By: Corey M. Ohayon
 Florida Bar No.: 0051323
 Attorney for Plaintiff:
 Brian L. Rosaler, Esquire
 Popkin & Rosaler, P.A.
 1701 West Hillsboro Boulevard,
 Suite 400
 Deerfield Beach, FL 33442
 Telephone: (954) 360-9030;
 Facsimile: (954) 420-5187
 12-33835
 May 30; June 6, 2014 14-02355S

FIRST INSERTION

NOTICE OF FORECLOSURE SALE IN THE CIRCUIT COURT OF THE 12TH JUDICIAL CIRCUIT, IN AND FOR SARASOTA COUNTY, FLORIDA

CIVIL DIVISION:
CASE NO.: 2010 CA 002330 NC
CHASE HOME FINANCE LLC,
Plaintiff, vs.
HERBERT L. BASS; UNITED STATES OF AMERICA
DEPARTMENT OF THE TREASURY; UNKNOWN SPOUSE OF HERBERT L. BASS; UNKNOWN TENANT(S); IN POSSESSION OF THE SUBJECT PROPERTY,
Defendants.

NOTICE IS HEREBY GIVEN pursuant to Final Judgment of Foreclosure dated the 10th day of March, 2014, and entered in Case No. 2010 CA 002330 NC, of the Circuit Court of the 12TH Judicial Circuit in and for Sarasota County, Florida, wherein CHASE HOME FINANCE LLC is the Plaintiff and HERBERT L. BASS; UNITED STATES OF AMERICA DEPARTMENT OF THE TREASURY and UNKNOWN TENANT(S) IN POSSESSION OF THE SUBJECT PROPERTY are defendants. The Clerk of this Court shall sell to the highest and best bidder for cash electronically at www.sarasota.realforeclose.com at 9:00 AM on the 19th day of June, 2014, the following described property as set forth in said Final Judgment, to wit:

LOT 8, CRECELIUS, ACCORDING TO THE PLAT THEREOF RECORDED IN PLAT BOOK 5, PAGE 73, OF THE PUBLIC RECORDS OF SARASOTA COUNTY, FLORIDA

ANY PERSON CLAIMING AN INTEREST IN THE SURPLUS FROM THE SALE, IF ANY, OTHER THAN THE PROPERTY OWNER AS OF THE DATE OF THE LIS PENDENS MUST FILE A CLAIM WITHIN 60 DAYS AFTER THE SALE.

If you are a person with a disability who needs any accommodation in order to participate in this proceeding, you are entitled, at no cost to you, to the provision of certain assistance. Please contact the Sarasota County Jury Office, P.O. Box 3079, Sarasota, Florida 34230-3079, (941)861-7400, at least seven (7) days before your scheduled court appearance, or immediately upon receiving this notification if the time before the scheduled appearance is less than seven (7) days; if you are hearing or voice impaired, call 711.

Dated this 19 day of May, 2014.
By: Jennifer Nicole Tarquinio
Bar #99192

Choice Legal Group, P.A.
P.O. Box 9908
Fort Lauderdale, FL 33310-0908
Telephone: (954) 453-0365
Facsimile: (954) 771-6052
Toll Free: 1-800-441-2438
DESIGNATED PRIMARY E-MAIL FOR SERVICE PURSUANT TO FLA R. JUD. ADMIN 2.516
eservice@clegalgroup.com
10-12704
May 30; June 6, 2014 14-02377S

FIRST INSERTION

NOTICE OF FORECLOSURE SALE IN THE CIRCUIT COURT IN AND FOR SARASOTA COUNTY, FLORIDA

CASE NO.: 2013 CA 001077 NC
JPMORGAN CHASE BANK,
NATIONAL ASSOCIATION
Plaintiff, vs.
ANDREW BULLEY A/K/A
ANDREW R. BULLEY; UNKNOWN SPOUSE OF ANDREW BULLEY A/K/A ANDREW R. BULLEY; UNKNOWN TENANT I; UNKNOWN TENANT II; CITIBANK, N.A., A NATIONAL BANKING ASSOCIATION; MAPLE HAMMOCK HOMEOWNERS' ASSOCIATION, INC., and any unknown heirs, devisees, grantees, creditors, and other unknown persons or unknown spouses claiming by, through and under any of the above-named Defendants,
Defendants.

NOTICE is hereby given that the Clerk of the Circuit Court of Sarasota County, Florida, will on the 16th day of June, 2014, at 9:00 AM, at www.sarasota.realforeclose.com, offer for sale and sell at public outcry to the highest and best bidder for cash, the following-described property situate in Sarasota County, Florida:

LOT 18, MAPLE HAMMOCK SUBDIVISION, AS PER PLAT THEREOF, RECORDED IN PLATBOOK 34, PAGE(S) 10, 10A, AND 10B, OF THE PUBLIC RECORDS OF SARASOTA COUNTY, FLORIDA.

pursuant to the Final Judgment entered in a case pending in said Court, the style of which is indicated above.

Any person or entity claiming an interest in the surplus, if any, resulting from the foreclosure sale, other than the property owner as of the date of the Lis Pendens, must file a claim on same with the Clerk of Court within 60 days after the foreclosure sale.

If you are a person with a disability who needs any accommodation in order to participate in this proceeding, you are entitled, at no cost to you, to the provision of certain assistance. Please contact the Sarasota County Jury Office, P.O. Box 3079, Sarasota, Florida 34230-3079, (941)861-7400, at least seven (7) days before your scheduled court appearance, or immediately upon receiving this notification if the time before the scheduled appearance is less than seven (7) days; if you are hearing or voice impaired, call 711.

DATED this 21st day of May, 2014
Alexandra E. Ritucci-Chinni
FL Bar # 073578 for
for Amanda Ann Shough, Esquire
Florida Bar No: 107073

BUTLER & HOSCH, P.A.
Mailing Address:
3185 South Conway Road, Suite E
Orlando, Florida 32812
Telephone: (407) 381-5200
Fax: (407) 381-5577
Attorney for Plaintiff
Service of Pleadings Email:
FLPleadings@butlerandhosch.com
B&H # 294647
May 30; June 6, 2014 14-02384S

FIRST INSERTION

NOTICE OF SALE IN THE CIRCUIT COURT OF THE TWELFTH JUDICIAL CIRCUIT OF THE STATE OF FLORIDA, IN AND FOR SARASOTA COUNTY CIVIL DIVISION

CASE NO. 58-2012-CA-003550-XXXA-NC
CITIMORTGAGE, INC.,
Plaintiff, vs.

JOHN H. BALL; UNKNOWN SPOUSE OF JOHN H. BALL; IF LIVING, INCLUDING ANY UNKNOWN SPOUSE OF SAID DEFENDANT(S), IF REMARRIED, AND IF DECEASED, THE RESPECTIVE UNKNOWN HEIRS, DEVISEES, GRANTEES, ASSIGNEES, CREDITORS, LIENORS, AND TRUSTEES, AND ALL OTHER PERSONS CLAIMING BY, THROUGH, UNDER OR AGAINST THE NAMED DEFENDANT(S); GULF COAST ASSISTANCE, LLC; IBERIABANK; CAPITAL ONE BANK; WHETHER DISSOLVED OR PRESENTLY EXISTING, TOGETHER WITH ANY GRANTEES, ASSIGNEES, CREDITORS, LIENORS, OR TRUSTEES OF SAID DEFENDANT(S) AND ALL OTHER PERSONS CLAIMING BY, THROUGH, UNDER, OR AGAINST DEFENDANT(S); UNKNOWN TENANT #1; UNKNOWN TENANT #2;
Defendant(s)

Notice is hereby given that, pursuant to a Final Summary Judgment of Foreclosure entered on 09/10/2013 in the above styled cause, in the Circuit Court of Sarasota County, Florida, the office of Karen E. Rushing clerk of the circuit court will sell the property situate in

Sarasota County, Florida, described as: LOTS 16, 17, 18 AND 19, BLOCK 14, BEVERLY TERRACE, UNIT NO. 2, ACCORDING TO THE PLAT THEREOF, AS RECORDED IN PLAT BOOK 2, PAGE 126, OF THE PUBLIC RECORDS OF SARASOTA COUNTY, FLORIDA.

at public sale, to the highest and best bidder, for cash, www.sarasota.realforeclose.com at 9:00 o'clock, A.M., on June 16, 2014

Any person claiming an interest in the surplus from the sale, if any, other than the property owner as of the date of the lis pendens, must file a claim within 60 days after the sale.

If you are a person with a disability who needs any accommodation in order to participate in this proceeding, you are entitled, at no cost to you, to the provision of certain assistance. Please contact the Sarasota County Jury Office, P.O. Box 3079, Sarasota, Florida 34230-3079, (941)861-7400, at least seven (7) days before your scheduled court appearance, or immediately upon receiving this notification if the time before the scheduled appearance is less than seven (7) days; if you are hearing or voice impaired, call 711.

ATTORNEY FOR PLAINTIFF
By /S/ Josh D. Donnelly
Josh D. Donnelly
Florida Bar #64788

Date: 05/22/2014
THIS INSTRUMENT PREPARED BY:
Law Offices Of Daniel C. Consuegra
9204 King Palm Drive
Tampa, FL 33619-1328
Phone: 813-915-8660
Attorneys for Plaintiff
91696
May 30; June 6, 2014 14-02380S

FIRST INSERTION

NOTICE OF SALE IN THE CIRCUIT COURT OF THE TWELFTH JUDICIAL CIRCUIT OF THE STATE OF FLORIDA, IN AND FOR SARASOTA COUNTY CIVIL DIVISION

CASE NO. 58-2009-CA-000100-XXXA-NC
BANK OF AMERICA, N.A.,
Plaintiff, vs.
LARRY JOHNSON AKA
LAWRENCE A. JOHNSON;
UNKNOWN SPOUSE OF LARRY JOHNSON AKA LAWRENCE A. JOHNSON IF ANY; ANY AND ALL UNKNOWN PARTIES CLAIMING BY, THROUGH, UNDER, AND AGAINST THE HEREIN NAMED INDIVIDUAL DEFENDANT(S) WHO ARE NOT KNOWN TO BE DEAD OR ALIVE, WHETHER SAID UNKNOWN PARTIES MAY CLAIM AN INTEREST AS SPOUSES, HEIRS, DEVISEES, GRANTEES OR OTHER CLAIMANTS; STATE OF FLORIDA DEPARTMENT OF REVENUE; GREGORY E. VINE; SUSAN A. VINE; JOHN DOE AND JANE DOE AS UNKNOWN TENANTS IN POSSESSION;
Defendant(s)

Notice is hereby given that, pursuant to a Final Summary Judgment of Foreclosure entered on 01/06/2014 in the above styled cause, in the Circuit Court of Sarasota County, Florida, the office of Karen E. Rushing clerk of the circuit court will sell the property situate in Sarasota County, Florida, described as:

LOT 254, SARASOTA GOLF CLUB COLONY SUBDIVISION, UNIT NO. 4, ACCORDING TO THE PLAT THEREOF, AS RECORDED IN PLAT BOOK 10, PAGE 13, OF THE PUBLIC RECORDS OF SARASOTA COUNTY, FLORIDA.

at public sale, to the highest and best bidder, for cash, www.sarasota.realforeclose.com at 9:00 o'clock, A.M., on June 16, 2014

Any person claiming an interest in the surplus from the sale, if any, other than the property owner as of the date of the lis pendens, must file a claim within 60 days after the sale.

If you are a person with a disability who needs any accommodation in order to participate in this proceeding, you are entitled, at no cost to you, to the provision of certain assistance. Please contact the Sarasota County Jury Office, P.O. Box 3079, Sarasota, Florida 34230-3079, (941)861-7400, at least seven (7) days before your scheduled court appearance, or immediately upon receiving this notification if the time before the scheduled appearance is less than seven (7) days; if you are hearing or voice impaired, call 711.

DATED this 23rd day of May, 2014.
By: Jennifer Nicole Tarquinio
Bar #99192

Choice Legal Group, P.A.
P.O. Box 9908
Fort Lauderdale, FL 33310-0908
Telephone: (954) 453-0365
Facsimile: (954) 771-6052
Toll Free: 1-800-441-2438
DESIGNATED PRIMARY E-MAIL FOR SERVICE PURSUANT TO FLA R. JUD. ADMIN 2.516
eservice@clegalgroup.com
10-41078
May 30; June 6, 2014 14-02378S

Choice Legal Group, P.A.
P.O. Box 9908
Fort Lauderdale, FL 33310-0908
Telephone: (954) 453-0365
Facsimile: (954) 771-6052
Toll Free: 1-800-441-2438
DESIGNATED PRIMARY E-MAIL FOR SERVICE PURSUANT TO FLA R. JUD. ADMIN 2.516
eservice@clegalgroup.com
10-12704
May 30; June 6, 2014 14-02377S

Choice Legal Group, P.A.
P.O. Box 9908
Fort Lauderdale, FL 33310-0908
Telephone: (954) 453-0365
Facsimile: (954) 771-6052
Toll Free: 1-800-441-2438
DESIGNATED PRIMARY E-MAIL FOR SERVICE PURSUANT TO FLA R. JUD. ADMIN 2.516
eservice@clegalgroup.com
10-41078
May 30; June 6, 2014 14-02378S

FIRST INSERTION

NOTICE OF SALE IN THE CIRCUIT CIVIL COURT OF THE TWELFTH JUDICIAL CIRCUIT OF FLORIDA, IN AND FOR SARASOTA COUNTY CIVIL DIVISION

Case No. 58-2012-CA-009310 NC
Division A
WELLS FARGO BANK, N.A.
SUCCESSOR BY MERGER TO
WACHOVIA BANK, N.A.
Plaintiff, vs.

H. WILLIAM RARDIN, DEBORAH RARDIN, SOUTH GATE COMMUNITY ASSOCIATION, INC., AND UNKNOWN TENANTS/ OWNERS,
Defendants.

Notice is hereby given, pursuant to Final Judgment of Foreclosure for Plaintiff entered in this cause on August 12, 2013, in the Circuit Court of Sarasota County, Florida, The Clerk of the Court will sell the property situated in Sarasota County, Florida described as:

LOT 5, BLOCK 110, SOUTH GATE UNIT NO. 26 SUBDIVISION, ACCORDING TO THE PLAT THEREOF RECORDED IN PLAT BOOK 10, PAGE 38, OF THE PUBLIC RECORDS OF SARASOTA COUNTY, FLORIDA.

and commonly known as: 2425 S BRINK AVE, SARASOTA, FL 34239; including the building, appurtenances, and fixtures located therein, at public sale, to the highest and best bidder, for cash, Sales are held online at: https://www.sarasota.realforeclose.com, on June 17, 2014 at 9:00 A.M.

Any persons claiming an interest in the surplus from the sale, if any, other than the property owner as of the date of the lis pendens must file a claim within 60 days after the sale.

If you are a person with a disability who needs any accommodation in order to participate in this proceeding, you are entitled, at no cost to you, to the provision of certain assistance. Please contact the Sarasota County Jury Office, P.O. Box 3079, Sarasota, Florida 34230-3079, (941)861-7400, at least seven (7) days before your scheduled court appearance, or immediately upon receiving this notification if the time before the scheduled appearance is less than seven (7) days; if you are hearing or voice impaired, call 711.

Karen E. Rushing
By: Frances Grace Cooper, Esquire
Attorney for Plaintiff

Edward B. Pritchard
(813) 229-0900 x1309
Kass Shuler, P.A.
P.O. Box 800
Tampa, FL 33601-0800
ForeclosureService@kasslaw.com
309150/1122918/jlh
May 30; June 6, 2014 14-02389S

FIRST INSERTION

NOTICE OF SALE IN THE CIRCUIT COURT OF THE TWELFTH JUDICIAL CIRCUIT IN AND FOR SARASOTA COUNTY, FLORIDA

CIVIL DIVISION
Case #: 2012-CA-006167-NC
JPMorgan Chase Bank, National Association, Successor in Interest by Purchase from the FDIC as Receiver of Washington Mutual Bank f/k/a Washington Mutual Bank, FA Plaintiff, vs.-

James D. Harper; RBC Bank (USA) f/k/a RBC Centura Bank d/b/a RBC Centura; Strathmore Villa Condominium Apartments Association, Inc.; Unknown Parties in Possession #1, If living, and all Unknown Parties claiming by, through, under and against the above named Defendant(s) who are not known to be dead or alive, whether said Unknown Parties may claim an interest as Spouse, Heirs, Devisees, Grantees, or Other Claimants; Unknown Parties in Possession #2, If living, and all Unknown Parties claiming by, through, under and against the above named Defendant(s) who are not known to be dead or alive, whether said Unknown Parties may claim an interest as Spouse, Heirs, Devisees, Grantees, or Other Claimants

NOTICE IS HEREBY GIVEN pursuant to order rescheduling foreclosure sale or Final Judgment, entered in Civil Case No. 2012-CA-006167-NC of the Circuit Court of the 12th Judicial Circuit in and for Sarasota County, Florida, wherein JPMorgan Chase Bank, National Association, Successor in Interest by Purchase from the FDIC as Receiver of Washington Mutual Bank f/k/a Washington Mutual Bank, FA, Plaintiff and Susan Flynn and Jo Ellen Gildersleeve and Rita M. Sipes are defendant(s), I, Clerk of Court, Karen E. Rushing, will sell to the highest and best bidder for cash VIA THE INTERNET AT WWW.SARASOTA.REALFORECLOSE.COM, AT 9:00 A.M. on June 16, 2014, the following described

property as set forth in said Final Judgment, to-wit:

VILLA 56, STRATHMORE VILLA CONDOMINIUM APARTMENTS, SECTION 7, AS PER DECLARATION OF CONDOMINIUM RECORDED IN O.R. BOOK 569, PAGES 841 THROUGH 860, INCLUSIVE, AND RESTATED DECLARATION OF CONDOMINIUM RECORDED IN O.R. BOOK 2516, PAGE 2634 AND AMENDMENTS THERETO, AND AS PER PLAT THEREOF, RECORDED IN CONDOMINIUM BOOK 1, PAGES 41 AND 41A, TOGETHER WITH AN UNDIVIDED INTEREST IN THE COMMON ELEMENTS APPURTENANT THERETO, OF THE PUBLIC RECORDS OF SARASOTA COUNTY, FLORIDA.

ANY PERSON CLAIMING AN INTEREST IN THE SURPLUS FROM THE SALE, IF ANY, OTHER THAN THE PROPERTY OWNER AS OF THE DATE OF THE LIS PENDENS MUST FILE A CLAIM WITHIN 60 DAYS AFTER THE SALE.

If you are a person with a disability who needs any accommodation in order to participate in this proceeding, you are entitled, at no cost to you, to the provision of certain assistance. Please contact the Sarasota County Jury Office, P.O. Box 3079, Sarasota, Florida 34230-3079, (941)861-7400, at least seven (7) days before your scheduled court appearance, or immediately upon receiving this notification if the time before the scheduled appearance is less than seven (7) days; if you are hearing or voice impaired, call 711.

Submitted By:
ATTORNEY FOR PLAINTIFF:
SHAPIRO, FISHMAN & GACHÉ, LLP
2424 North Federal Highway,
Suite 360
Boca Raton, Florida 33431
(561) 998-6700
(561) 998-6707
11-219418 FC01 W50
May 30; June 6, 2014 14-02402S

FIRST INSERTION

NOTICE OF RESCHEDULED SALE IN THE CIRCUIT COURT OF THE TWELFTH JUDICIAL CIRCUIT IN AND FOR SARASOTA COUNTY, FLORIDA

CIVIL ACTION
CASE NO.: 2009 CA 012483 NC
DIVISION: A
WACHOVIA MORTGAGE, FSB
F/K/A WORLD SAVINGS BANK,
FSB,
Plaintiff, vs.

HOLMES, SARAH et al,
Defendant(s).

NOTICE IS HEREBY GIVEN Pursuant to an Order Rescheduling Foreclosure Sale dated on or about May 14, 2014, and entered in Case No. 2009 CA 012483 NC of the Circuit Court of the Twelfth Judicial Circuit in and for Sarasota County, Florida in which Wachovia Mortgage, FSB f/k/a World Savings Bank, FSB, is the Plaintiff and Sarah Lee Holmes, are defendants, the Sarasota County Clerk of the Circuit Court will sell to the highest and best bidder for cash the Internet: www.sarasota.realforeclose.com in/on, Sarasota County, Florida at 9:00am on the 18th day of June, 2014, the following described property as set forth in said Final Judgment of Foreclosure:

LOT 12, IN BLOCK 345, OF THIRD ADDITION TO PORT CHARLOTTE SUBDIVISION, ACCORDING TO THE PLAT THEREOF, AS RECORDED IN PLAT BOOK 11, AT PAGE 31, OF THE PUBLIC RECORDS OF SARAOSTA, COUNTY, FLORIDA.

5822 ESPANOLA AVENUE, NORTH PORT, FL 34287
Any person claiming an interest in the surplus from the sale, if any, other than the property owner as of the date of the Lis Pendens must file a claim within 60 days after the sale.

If you are a person with a disability who needs any accommodation in order to participate in this proceeding, you are entitled, at no cost to you, to the provision of certain assistance. Please contact the Sarasota County Jury Office, P.O. Box 3079, Sarasota, Florida 34230-3079, (941)861-7400, at least seven (7) days before your scheduled court appearance, or immediately upon receiving this notification if the time before the scheduled appearance is less than seven (7) days; if you are hearing or voice impaired, call 711.

Albertelli Law
Attorney for Plaintiff
P.O. Box 23028
Tampa, FL 33623
(813) 221-4743
(813) 221-9171 facsimile
eService: servealaw@albertellilaw.com
JR-09-21561
May 30; June 6, 2014 14-02374S

FIRST INSERTION

NOTICE OF FORECLOSURE SALE IN THE CIRCUIT COURT OF THE TWELFTH JUDICIAL CIRCUIT IN AND FOR SARASOTA COUNTY, FLORIDA

GENERAL JURISDICTION DIVISION
Case No. 2011 CA 007297 NC

Capital One, N.A.,
Plaintiff, vs.
Fred Kanaan a/k/a Frederick J. Kanaan et al.,
Defendants.

NOTICE IS HEREBY GIVEN pursuant to a Final Judgment of Foreclosure dated February 12, 2014, entered in Case No. 2011 CA 007297 NC of the Circuit Court of the Twelfth Judicial Circuit, in and for Sarasota County, Florida, wherein Capital One, N.A. is the Plaintiff and Fred Kanaan a/k/a Frederick J. Kanaan; Margaret Kanaan a/k/a Margaret A. Kanaan; Mortgage Electronic Registration Systems, Inc., acting solely as a nominee for Greenpoint Mortgage Funding, Inc. Min#: 100013800871204083; Unknown Tenant No. 1; Unknown Tenant No. 2; Unknown Tenant No. 3; Unknown Tenant No. 4; Unknown Tenant No. 5; Unknown Tenant No. 6; and all unknown parties claiming interests by, through, under or against a named defendant to this action, or having or claiming to have any right, title or interest in the property herein described are the Defendants, that the Clerk of Courts will sell to the highest and best bidder for cash by electronic sale at www.sarasota.realforeclose.com, beginning at 9:00 AM on the 12th day of June, 2014, the following described property as set forth in said Final Judgment, to wit:

LOT 6, BLOCK 2, ACCORDING TO THE PLAT OF NOKOMIS, AS SAID PLAT APPEARS OF RECORD IN PLAT BOOK 1, PAGES 11 AND 11 1/2 OF THE PUBLIC RECORDS OF SARASOTA COUNTY, FLORIDA, TOGETHER WITH THE LAND ON THE SEAWARD

SIDE OF SUNSET DRIVE IN FRONT OF THE AFORESAID PROPERTY AND LYING BETWEEN AN EXTENSION OF THE EASTERLY AND WESTERLY LINES OF AFORESAID DESCRIBED PROPERTY, AND ANY AND ALL RIPARIAN RIGHTS THEREUNTO BELONGING OR IN ANYWISE APPERTAINING, BUT SUBJECT TO THE TERMS AND CONDITIONS OR THAT CERTAIN AGREEMENT DATED NOVEMBER 6, 1935 APPEARING OF RECORD IN DEED BOOK 136, PAGE 192, OF THE PUBLIC RECORDS OF SARASOTA COUNTY, FLORIDA.

Any person claiming an interest in the surplus from the sale, if any, other than the property owner as of the date of the lis pendens must file a claim within 60 days after the sale.

If you are a person with a disability who needs any accommodation in order to participate in this proceeding, you are entitled, at no cost to you, to the provision of certain assistance. Please contact the Sarasota County Jury Office, P.O. Box 3079, Sarasota, Florida 34230-3079, (941)861-7400, at least seven (7) days before your scheduled court appearance, or immediately upon receiving this notification if the time before the scheduled appearance is less than seven (7) days; if you are hearing or voice impaired, call 711.

Dated this 22nd day of May, 2014.
By Jimmy K. Edwards, Esq.
FL Bar No. 81855
Kathleen McCarthy, Esq.
Florida Bar No. 72161

BROCK & SCOTT, PLLC
Attorney for Plaintiff
1501 N.W. 49th Street, Suite 200
Ft. Lauderdale, FL 33309
Phone: (954) 618-6955, ext. 6177
Fax: (954) 618-6954
FLCourtDocs@brockandscott.com
File # 13-F04943
May 30; June 6, 2014 14-02375S

FIRST INSERTION

NOTICE OF SALE
IN THE CIRCUIT CIVIL COURT OF
THE TWELFTH JUDICIAL
CIRCUIT OF FLORIDA, IN AND
FOR SARASOTA COUNTY
CIVIL DIVISION
Case No. 58-2013-CA-006617 NC
Division A

U.S. BANK NATIONAL
ASSOCIATION, AS TRUSTEE
FOR CITIGROUP MORTGAGE
LOAN TRUST INC. 2007-AR7,
MORTGAGE PASS THROUGH
CERTIFICATES, SERIES 2007-AR7
Plaintiff, vs.
CLIFFORD PIERCE, LEAH
PIERCE, BANK OF AMERICA,
N.A., CHASE BANK USA, N.A.,
FOREST LAKES COUNTRY
CLUB ESTATES HOMEOWNERS
ASSOCIATION, INC., AND
UNKNOWN TENANTS/OWNERS,
Defendants.

Notice is hereby given, pursuant to
Final Judgment of Foreclosure for
Plaintiff entered in this cause on
May 12, 2014, in the Circuit Court of
Sarasota County, Florida, The Clerk of
the Court will sell the property situated
in Sarasota County, Florida described as:

LOT 8, BLOCK D OF FOR-
EST LAKES COUNTRY CLUB
ESTATES UNIT NO. 10, AC-
CORDING TO THE PLAT
THEREOF AS RECORDED IN
PLAT BOOK 22 PAGE 18 OF
THE PUBLIC RECORDS OF
SARASOTA COUNTY, FLOR-
IDA.

and commonly known as: 2126
TANGLEWOOD DR, SARASOTA,
FL 34239; including the building,
appurtenances, and fixtures located
therein, at public sale, to the highest
and best bidder, for cash, Sales are
held online at: [https://www.sarasota.
realforeclose.com](https://www.sarasota.realforeclose.com), on June 18, 2014 at
9:00 A.M..

Any persons claiming an interest in
the surplus from the sale, if any, other
than the property owner as of the date
of the lis pendens must file a claim
within 60 days after the sale.

If you are a person with a disability
who needs any accommodation in
order to participate in this
proceeding, you are entitled, at
no cost to you, to the provision of
certain assistance. Please contact
the Sarasota County Jury Office, P.O.
Box 3079, Sarasota, Florida 34230-
3079, (941)861-7400, at least seven
(7) days before your scheduled court
appearance, or immediately upon
receiving this notification if the time
before the scheduled appearance is
less than seven (7) days; if you are
hearing or voice impaired, call 711.

Karen E. Rushing
By: Frances Grace Cooper, Esquire
Attorney for Plaintiff

Edward B. Pritchard
(813) 229-0900 x1309
Kass Shuler, P.A.
P.O. Box 800
Tampa, FL 33601-0800
ForeclosureService@kasslaw.com
327611/1335950/jlh
May 30; June 6, 2014 14-02387S

FIRST INSERTION

NOTICE OF SALE
IN THE CIRCUIT COURT OF THE
TWELFTH JUDICIAL CIRCUIT OF
THE STATE OF FLORIDA, IN AND
FOR SARASOTA COUNTY
CIVIL DIVISION
CASE NO.

58-2010-CA-008088-XXXX-NC
U.S. BANK NATIONAL
ASSOCIATION ND,
Plaintiff, vs.

CARLOS C. TAVARES
A/K/A CARLOS TAVARES;
ALESSANDRA L. TAVARES
A/K/A ALESSANDRA TAVARES;
IF LIVING, INCLUDING ANY
UNKNOWN SPOUSE OF SAID
DEFENDANT(S), IF REMARRIED,
AND IF DECEASED, THE
RESPECTIVE UNKNOWN
HEIRS, DEVISEES, GRANTEEES,
ASSIGNEES, CREDITORS,
LIENORS, AND TRUSTEES,
AND ALL OTHER PERSONS
CLAIMING BY, THROUGH,
UNDER OR AGAINST THE
NAMED DEFENDANT(S); PAVER
SYSTEMS, LLC; WHETHER
DISSOLVED OR PRESENTLY
EXISTING, TOGETHER WITH
ANY GRANTEEES, ASSIGNEES,
CREDITORS, LIENORS,
OR TRUSTEES OF SAID
DEFENDANT(S) AND ALL
OTHER PERSONS CLAIMING
BY, THROUGH, UNDER, OR
AGAINST DEFENDANT(S);
Defendant(s)

Notice is hereby given that, pursuant
to a Final Summary Judgment of
Foreclosure entered on 01/06/2014 in
the above styled cause, in the Circuit
Court of Sarasota County, Florida, the
office of Karen E. Rushing clerk of
the circuit court will sell the property
situate in Sarasota County, Florida,
described as:

THE EAST 80 FEET OF LOT
14, BLOCK A, HOPE ACRES
SUBDIVISION, ACCORDING

FIRST INSERTION

NOTICE OF SALE
IN THE CIRCUIT CIVIL COURT OF
THE TWELFTH JUDICIAL
CIRCUIT OF FLORIDA,
IN AND FOR
SARASOTA COUNTY
CIVIL DIVISION
Case No. 58-2013-CA-002806 NC
Division C

U.S. BANK NATIONAL
ASSOCIATION
Plaintiff, vs.
CHERYL A. CARUSO, LEONARD
A. CARUSO, VENETIAN GOLF
& RIVER CLUB PROPERTY
OWNERS ASSOCIATION, INC.
F/K/A VENETIAN GOLF & RIVER
CLUB MASTER ASSOCIATION,
INC., TIZIANO II AT VENETIAN
GOLF & RIVER CLUB PROPERTY
OWNERS ASSOCIATION, INC.,
WCI COMMUNITIES, LLC, AND
UNKNOWN TENANTS/OWNERS,
Defendants.

Notice is hereby given, pursuant to
Final Judgment of Foreclosure for
Plaintiff entered in this cause on
May 12, 2014, in the Circuit Court of
Sarasota County, Florida, The Clerk of
the Court will sell the property situated
in Sarasota County, Florida described as:

LOT 39, VENETIAN GOLF
& RIVER CLUB, PHASE 4A,
ACCORDING TO THE PLAT
THEREOF RECORDED IN
PLAT BOOK 45, PAGES 18,
18A AND 18B, OF THE PUB-
LIC RECORDS OF SARASOTA
COUNTY, FLORIDA.

and commonly known as: 334
MESTRE PL, NORTH VENICE,
FL 34275; including the building,
appurtenances, and fixtures located
therein, at public sale, to the highest
and best bidder, for cash, Sales are
held online at: [https://www.sarasota.
realforeclose.com](https://www.sarasota.realforeclose.com), on June 18, 2014 at
9:00 A.M..

Any persons claiming an interest in
the surplus from the sale, if any, other
than the property owner as of the date
of the lis pendens must file a claim
within 60 days after the sale.

If you are a person with a disability
who needs any accommodation in
order to participate in this
proceeding, you are entitled, at
no cost to you, to the provision of
certain assistance. Please contact
the Sarasota County Jury Office, P.O.
Box 3079, Sarasota, Florida 34230-
3079, (941)861-7400, at least seven
(7) days before your scheduled court
appearance, or immediately upon
receiving this notification if the time
before the scheduled appearance is
less than seven (7) days; if you are
hearing or voice impaired, call 711.

Karen E. Rushing
By: Frances Grace Cooper, Esquire
Attorney for Plaintiff

Edward B. Pritchard
(813) 229-0900 x1309
Kass Shuler, P.A.
P.O. Box 800
Tampa, FL 33601-0800
ForeclosureService@kasslaw.com
327603/1134954/jlh
May 30; June 6, 2014 14-02388S

FIRST INSERTION

NOTICE OF SALE
IN THE CIRCUIT CIVIL COURT OF
THE TWELFTH JUDICIAL
CIRCUIT OF FLORIDA, IN AND
FOR SARASOTA COUNTY
CIVIL DIVISION
Case No. 58-2012-CA-008131 NC
Division A

WELLS FARGO BANK, N.A.
Plaintiff, vs.
KELLE L. BROOKS A/K/A KELLE
L. EVANS, LEONARD P. BROOKS,
JR. AND UNKNOWN TENANTS/
OWNERS,
Defendants.

Notice is hereby given, pursuant to
Final Judgment of Foreclosure for
Plaintiff entered in this cause on
March 10, 2014, in the Circuit Court of
Sarasota County, Florida, The Clerk of
the Court will sell the property situated
in Sarasota County, Florida described as:

THE FOLLOWING DE-
SCRIBED LOT, PIECE OR
PARCEL OF LAND, SITUATE,
LYING AND BEING IN THE
COUNTY OF SARASOTA,
STATE OF FLORIDA, TO-
WIT: LOT 744, SARASOTA
SPRINGS, UNIT NO. 6, AS PER
PLAT THEREOF RECORDED
IN PLAT BOOK 8, PAGE 22 OF
THE PUBLIC RECORDS OF
SARASOTA COUNTY, FLOR-
IDA.

and commonly known as: 4223
CHARDON WAY, SARASOTA,
FL 34232; including the building,
appurtenances, and fixtures located
therein, at public sale, to the highest
and best bidder, for cash, Sales are
held online at: [https://www.sarasota.
realforeclose.com](https://www.sarasota.realforeclose.com), on June 18, 2014 at
9:00 A.M..

Any persons claiming an interest in
the surplus from the sale, if any, other
than the property owner as of the date
of the lis pendens must file a claim
within 60 days after the sale.

If you are a person with a disability
who needs any accommodation in
order to participate in this
proceeding, you are entitled, at
no cost to you, to the provision of
certain assistance. Please contact
the Sarasota County Jury Office, P.O.
Box 3079, Sarasota, Florida 34230-
3079, (941)861-7400, at least seven
(7) days before your scheduled court
appearance, or immediately upon
receiving this notification if the time
before the scheduled appearance is
less than seven (7) days; if you are
hearing or voice impaired, call 711.

Karen E. Rushing
By: Frances Grace Cooper, Esquire
Attorney for Plaintiff

Edward B. Pritchard
(813) 229-0900 x1309
Kass Shuler, P.A.
P.O. Box 800
Tampa, FL 33601-0800
ForeclosureService@kasslaw.com
327611/1111379/jlh
May 30; June 6, 2014 14-02390S

FIRST INSERTION

NOTICE OF SALE
IN THE CIRCUIT COURT OF THE
TWELFTH JUDICIAL CIRCUIT
IN AND FOR SARASOTA COUNTY,
FLORIDA
CIVIL DIVISION
Case #: 2012-CA-008648-NC
DIVISION: C

JPMorgan Chase Bank, National
Association, Successor by Merger
to Chase Home Finance, LLC,
Successor by Merger to Chase
Manhattan Mortgage Corporation
Plaintiff, vs.

Michael James Schmucker II a/k/a
Michael James Schmucker a/k/a
Michael J. Schmucker II a/k/a
Michael J. Schmucker Jr.
a/k/a Michael J. Schmucker II;
The Unknown Spouse of Michael
James Schmucker II a/k/a Michael
James Schmucker a/k/a Michael J.
Schmucker II a/k/a Michael James
Schmucker Jr. a/k/a Michael J.
Schmucker II; Ford Motor Credit
Company LLC; Unknown Parties
in Possession #1, If living, and all
Unknown Parties claiming by,
through, under and against the
above named Defendant(s) who
are not known to be dead or alive,
whether said Unknown Parties
may claim an interest as Spouse,
Heirs, Devisees, Grantees, or Other
Claimants; Unknown Parties in
Possession #2, If living, and all
Unknown Parties claiming by,
through, under and against the
above named Defendant(s) who
are not known to be dead or alive,
whether said Unknown Parties
may claim an interest as Spouse,
Heirs, Devisees, Grantees, or Other
Claimants
Defendant(s).

NOTICE IS HEREBY GIVEN pursu-
ant to order rescheduling foreclosure
sale or Final Judgment, entered in Civil
Case No. 2012-CA-008648-NC of the
Circuit Court of the 12th Judicial Cir-
cuit in and for Sarasota County, Flor-
ida, wherein JPMorgan Chase Bank,
National Association, Successor by
Merger to Chase Home Finance, LLC,
Successor by Merger to Chase Man-
hattan Mortgage Corporation, Plain-

FIRST INSERTION

NOTICE OF FORECLOSURE SALE
IN THE CIRCUIT COURT OF THE
TWELFTH JUDICIAL CIRCUIT OF
FLORIDA IN AND FOR
SARASOTA COUNTY
GENERAL JURISDICTION
DIVISION
CASE NO. 2010 CA 004835 NC

BMO HARRIS BANK, N.A.,
Plaintiff, vs.
ALICJA DUDEK, et al.,
Defendants.

NOTICE IS HEREBY GIVEN pursu-
ant to a Summary Final Judgment of
Foreclosure entered August 26, 2013
in Civil Case No. 2010 CA 004835 NC
of the Circuit Court of the TWELFTH
Judicial Circuit in and for Sarasota
County, Sarasota, Florida, wherein
BMO HARRIS BANK, N.A. is Plain-
tiff and ALICJA DUDEK, TADEUSZ
DUDEK, TADEUSZ DUDEK, ALICJA
DUDEK, UNKNOWN TENANT #1,
UNKNOWN TENANT #2, are Defen-
dants, the Clerk of Court will sell to
the highest and best bidder for cash
electronically at www.sarasota.realforeclose.com
in accordance with Chapter
45, Florida Statutes on the 19th day of
June, 2014 at 09:00 AM on the follow-
ing described property as set forth in
said Summary Final Judgment, to-wit:

LOT 78, CEDAR HOLLOW,
ACCORDING TO THE PLAT
THEREOF, AS RECORDED IN
PLAT BOOK 29, PAGES 18, 18A
THROUGH 18D, INCLUSIVE,
PUBLIC RECORDS OF SARA-
SOTA COUNTY, FLORIDA.

Any person claiming an interest in the
surplus from the sale, if any, other than
the property owner as of the date of the
lis pendens, must file a claim within 60
days after the sale.

If you are a person with a disability
who needs any accommodation in
order to participate in this
proceeding, you are entitled, at no
cost to you, to the provision of cer-
tain assistance. Please contact the
Sarasota County Jury Office, P.O. Box
3079, Sarasota, Florida 34230-3079,
(941)861-7400, at least seven (7) days
before your scheduled court appear-
ance, or immediately upon receiving
this notification if the time before
the scheduled appearance is less than
seven (7) days; if you are hearing or
voice impaired, call 711.

Heidi Sasha Kirlaw, ESQ
FLA.BAR #56397
Brian Hummel, Esq.
Fla. Bar No.: 46162

McCalla Rayermer, LLC
Attorney for Plaintiff
225 E. Robinson St.
Suite 660
Orlando, FL 32801
Phone: (407) 674-1850
Fax: (321) 248-0420
Email:
MRSservice@mcallarayermer.com
2827232
11-02403-6
May 30; June 6, 2014 14-02392S

FIRST INSERTION

NOTICE OF SALE
IN THE CIRCUIT COURT OF THE
TWELFTH JUDICIAL CIRCUIT
IN AND FOR SARASOTA COUNTY,
FLORIDA

Case No.: 2010 CA 003006 NC
Section: CIRCUIT CIVIL A
CITIBANK, N.A. AS SUCCESSOR
BY MERGER TO CITIBANK, FSB
Plaintiff, v.

JOHN SCOLARO; LUCIA
SCOLARO; HEIDI SCOLARO;
MARIO ANGELO SCOLARO;
UNKNOWN SPOUSE OF ALICIA
MORALEE; ANY AND ALL
UNKNOWN PARTIES CLAIMING
BY, THROUGH, UNDER, AND
AGAINST THE HEREIN NAMED
INDIVIDUAL DEFENDANT(S)
WHO ARE NOT KNOWN TO BE
DEAD OR ALIVE, WHETHER
SAID UNKNOWN PARTIES
MAY CLAIM AN INTEREST AS
SPOUSES, HEIRS, DEVISEES,
GRANTEES, OR OTHER
CLAIMANTS; AND VENETIA
COMMUNITY ASSOCIATION,
INC.

Defendant(s).
NOTICE IS HEREBY GIVEN pursu-
ant to an Order of Uniform Final Judg-
ment of Mortgage Foreclosure dated
April 4, 2014, entered in Civil Case No.
2010 CA 003006 NC of the Circuit
Court of the Twelfth Judicial Circuit
in and for Sarasota County, Florida,
wherein the Clerk of the Circuit Court
will sell to the highest bidder for cash
on the 13th day of June, 2014, at 9:00
a.m. online at the website: [https://
www.sarasota.realforeclose.com](https://www.sarasota.realforeclose.com), rela-
tive to the following described property

as set forth in the Final Judgment, to
wit:

LOT 5, BLOCK "C", COUNTRY
CLUB ESTATES, UNIT 2, AS
PER PLAT THEREOF RECOR-
DED IN PLAT BOOK 5, PAGE 29-
A, OF THE PUBLIC RECORDS
OF SARASOTA COUNTY,
FLORIDA.

Any person claiming an interest in the
surplus from the sale, if any, other than
the property owner as of the date of the
Lis Pendens must file a claim within 60
days after the sale.

If you are a person with a disability
who needs any accommodation in order
to participate in this proceeding, you
are entitled, at no cost to you, to the
provision of certain assistance. Please
contact the Sarasota County Jury Of-
fice, P.O. Box 3079, Sarasota, Florida
34230-3079, (941)861-7400, at least
seven (7) days before your scheduled
court appearance, or immediately upon
receiving this notification if the time
before the scheduled appearance is less
than seven (7) days; if you are hearing
or voice impaired, call 711.

MORRIS|HARDWICK|
SCHNEIDER, LLC
Kelly Sanchez, Esq., FBN: 102378
9409 Philadelphia Road
Baltimore, Maryland 21237

Mailing Address:
Morris|Hardwick|Schneider, LLC
5110 Eisenhower Blvd., Suite 302A
Tampa, Florida 33634
Customer Service (866)-503-4930
MHSinbox@closingsource.net
FL-97007962-10
10648245
May 30; June 6, 2014 14-02353S

FIRST INSERTION

NOTICE OF SALE
IN THE CIRCUIT COURT OF THE
TWELFTH JUDICIAL CIRCUIT IN
AND FOR SARASOTA COUNTY,
FLORIDA,
CIVIL ACTION

CASE NO.: 2009-CA-012991-NC
THE BANK OF NEW YORK
MELLON F/K/A THE BANK OF
NEW YORK, AS TRUSTEE FOR
THE CERTIFICATEHOLDERS
CVALT, INC. ALTERNATIVE
LOAN TRUST 2005-54CB
MORTGAGE PASS-THROUGH
CERTIFICATES, SERIES
2005-54CB,
Plaintiff vs.
WAYNE LEWIS, et al.
Defendant(s)

Notice is hereby given that, pursuant
to a Final Judgment of Foreclosure
dated April 22, 2014 entered in Civil
Case Number 2009-CA-012991-NC, in
the Circuit Court for Sarasota County,
Florida, wherein THE BANK OF
NEW YORK MELLON F/K/A THE
BANK OF NEW YORK, AS TRUSTEE
FOR THE CERTIFICATEHOLDERS
CVALT, INC. ALTERNATIVE LOAN
TRUST 2005-54CB MORTGAGE
PASS-THROUGH CERTIFICATES,
SERIES 2005-54CB is the Plain-
tiff, and WAYNE V. LEWIS A/K/A
WAYNE LEWIS, et al., are the Defen-
dants, Sarasota County Clerk of Court
will sell the property situated in Sara-
sota County, Florida, described as:
LOT 19 AND 20, BLOCK 861,
FIRST REPLAT IN SIXTEENTH
ADDITION TO PORT CHAR-
LOTTE SUBDIVISION, A SUB-
DIVISION, ACCORDING TO

THE PLAT THEREOF AS RE-
CORDED IN PLAT BOOK 20,
PAGES 12 AND 12A THROUGH
12E, OF THE PUBLIC RE-
CORDS OF SARASOTA COUN-
TY, FLORIDA

at public sale, to the highest and best
bidder, for cash, at www.sarasota-realforeclose.com
at 09:00 AM, on the
20th day of August, 2014. Any person
claiming an interest in the surplus from
the sale, if any, other than the property
owner as of the date of the lis pendens
must file a claim within 60 days after
the sale.

If you are a person with a disability
who needs any accommodation in
order to participate in this proceed-
ing, you are entitled, at no cost to you,
to the provision of certain assistance.
Please contact the Sarasota County
Jury Office, P.O. Box 3079, Sarasota,
Florida 34230-3079, (941)861-7400,
at least seven (7) days before your
scheduled court appearance, or imme-
diately upon receiving this notification
if the time before the scheduled ap-
pearance is less than seven (7) days;
if you are hearing or voice impaired,
call 711.

Dated: May 22, 2014
By: /s/ Marissa M. Yaker
Marissa M. Yaker, Esquire
(FBN 103591)

FLORIDA FORECLOSURE
ATTORNEYS, PLLC
4855 Technology Way, Suite 500
Boca Raton, FL 33431
(727) 446-4826
emailservice@ffapllc.com
Our File No: CA11-00825/CQ
May 30; June 6, 2014 14-02385S

FIRST INSERTION

NOTICE OF SALE
IN THE CIRCUIT COURT OF THE
TWELFTH JUDICIAL CIRCUIT OF
THE STATE OF FLORIDA, IN AND
FOR SARASOTA COUNTY
CIVIL DIVISION
CASE NO.

58-2009-CA-008035-XXXX-NC
HOUSEHOLD FINANCE
CORPORATION III,
Plaintiff, vs.

STANLEY A. HARRIS;
UNKNOWN SPOUSE OF
STANLEY A. HARRIS; LINDA
HARRIS; UNKNOWN SPOUSE
OF LINDA HARRIS; IF
LIVING, INCLUDING ANY
UNKNOWN SPOUSE OF SAID
DEFENDANT(S), IF REMARRIED,
AND IF DECEASED, THE
RESPECTIVE UNKNOWN
HEIRS, DEVISEES, GRANTEEES,
ASSIGNEES, CREDITORS,
LIENORS, AND TRUSTEES, AND
ALL OTHER PERSONS CLAIMING
BY, THROUGH, UNDER,
OR AGAINST THE NAMED
DEFENDANT(S); RIVIERA
CLUB VILLAGE HOMEOWNERS'
ASSOCIATION, INC.; WHETHER
DISSOLVED OR PRESENTLY
EXISTING, TOGETHER WITH
ANY GRANTEEES, ASSIGNEES,
CREDITORS, LIENORS,
OR TRUSTEES OF SAID
DEFENDANT(S) AND ALL
OTHER PERSONS CLAIMING
BY, THROUGH, UNDER, OR
AGAINST DEFENDANT(S);
UNKNOWN TENANT #1;
UNKNOWN TENANT #2;
Defendant(s)

Notice is hereby given that, pursuant
to a Final Summary Judgment of Fore-
closure entered on 08/06/2010 in the
above styled cause, in the Circuit Court
of Sarasota County, Florida, the office

of Karen E. Rushing clerk of the circuit
court will sell the property situate in
Sarasota County, Florida, described as:
LOT 25, RIVIERA CLUB VIL-
LAGE, PHASE ONE, AS PER
PLAT THEREOF RECORDED
IN PLAT BOOK 32, PAGES 48
AND 48A OF THE PUBLIC RE-
CORDS OF SARASOTA COUN-
TY, FLORIDA.

at public sale, to the highest and best
bidder, for cash, www.sarasota-realforeclose.com
at 9:00 o'clock, A.M., on
June 16, 2014

Any person claiming an interest in
the surplus from the sale, if any, other
than the property owner as of the date
of the lis pendens, must file a claim
within 60 days after the sale.

If you are a person with a disability
who needs any accommodation in
order to participate in this proceed-
ing, you are entitled, at no cost to you,
to the provision of certain assistance.
Please contact the Sarasota County
Jury Office, P.O. Box 3079, Sarasota,
Florida 34230-3079, (941)861-7400,
at least seven (7) days before your
scheduled court appearance, or imme-
diately upon receiving this notification
if the time before the scheduled ap-
pearance is less than seven (7) days;
if you are hearing or voice impaired,
call 711.

ATTORNEY FOR PLAINTIFF
By /s/ Josh D. Donnelly
Josh D. Donnelly
Florida Bar #64788

Date: 05/22/2014
THIS INSTRUMENT PREPARED BY:
Law Offices Of Daniel C. Consuegra
9204 King Palm Drive
Tampa, FL 33619-1328
Phone: 813-915-8660
Attorneys for Plaintiff
41052
May 30; June 6, 2014 14-02382S

FIRST INSERTION

NOTICE OF SALE
IN THE CIRCUIT COURT OF THE
TWELFTH JUDICIAL CIRCUIT
IN AND FOR SARASOTA COUNTY,
FLORIDA

Case No. 2008 CA 8119 SC
STEPHEN A. WITZER, as Trustee
u/a/d February 7, 1985,
Plaintiff, v.
ROBERT W. DILLS, an individual,
MARTHA C. DILLS, an individual,
UNI-GLIDE MANUFACTURING
CO., INC., a Florida corporation,
UNI-GLIDE TRAILER COMPANY,
a Florida corporation, NCN
ELECTRIC, INC., a Florida
corporation, ALL OTHER
PERSONS OF INTEREST,
UNKNOWN PERSON IN
POSSESSION OF SUBJECT REAL
PROPERTY, IF ANY.

Defendant
NOTICE IS HEREBY GIVEN pursuant to an Order of Final Judgment of Foreclosure dated April 7, 2014, entered in Civil Case No.: 2008 CA 8119 SC, of the Circuit Court of the Twelfth Judicial Circuit in and for Sarasota County, Florida, wherein STEPHEN A. WITZER, as Trustee u/a/d 2/7/1985 is the Plaintiff and Robert W. Dills, Martha C. Dills, Uni-Glide Manufacturing Co., Inc., Uni-Glide Trailer Company and NCN Electric, Inc., are Defendants. I will sell to the highest bidder for cash via foreclosure sale conducted via the Internet at www.sarasota.realforeclose.com on June 24, 2014 at 9:00 a.m. on the following described property as set forth in said Final Judgment, to-wit:

Lot 1, CENTER ROAD INDUSTRIAL PARK, according to the plat thereof recorded in Plat Book 27, page 47, Public Records of Sarasota County, Florida.
ANY PERSON CLAIMING AN INTEREST IN THE SURPLUS FROM THE SALE, IF ANY, OTHER THAN THE PROPERTY OWNER AS OF THE DATE OF THE LIS PENDENS MUST FILE A CLAIM WITHIN 60 DAYS AFTER THE SALE.

If you are a person with a disability who needs any accommodation in order to participate in this proceeding, you are entitled, at no cost to you, to the provision of certain assistance. Please contact the Sarasota County Jury Office, P.O. Box 3079, Sarasota, Florida 34230-3079, (941)861-7400, at least seven (7) days before your scheduled court appearance, or immediately upon receiving this notification if the time before the scheduled appearance is less than seven (7) days; if you are hearing or voice impaired, call 711.

DATED at Sarasota, Sarasota County, Florida this 22nd day of May, 2014.
ALEXANDER G. PADEREWSKI
May 30; June 6, 2014 14-02396S

FIRST INSERTION

NOTICE OF SALE
IN THE CIRCUIT COURT OF THE
TWELFTH JUDICIAL CIRCUIT OF
THE STATE OF FLORIDA, IN AND
FOR SARASOTA COUNTY
CIVIL DIVISION

Case No. 58-2012-CA-007775-0000-NC
GREEN TREE SERVICING LLC,
Plaintiff, vs.
CLIFFORD KLAWITTER;
UNKNOWN SPOUSE OF
CLIFFORD KLAWITTER; JANE
KLAWITTER; UNKNOWN
SPOUSE OF JANE KLAWITTER;
WASHINGTON FEDERAL
SUCCESSOR BY MERGER
TO FIRST MUTUAL BANK;
UNKNOWN TENANT #1;
UNKNOWN TENANT #2;
Defendant(s)
Notice is hereby given that, pursuant to a Final Summary Judgment of Foreclosure entered on 09/23/2013 in the above styled cause, in the Circuit Court of Sarasota County, Florida, the office of Karen E. Rushing clerk of the circuit court will sell the property situate in Sarasota County, Florida, described as:
Lots 15285 and 15286, SOUTH VENICE UNIT NO. 58, according to the plat thereof, as recorded in Plat Book 7, Page 28, of the Public Records of Sarasota County, Florida.

at public sale, to the highest and best bidder, for cash, www.sarasota.realforeclose.com at 9:00 o'clock, A.M., on June 16, 2014

Any person claiming an interest in the surplus from the sale, if any, other than the property owner as of the date of the lis pendens, must file a claim within 60 days after the sale.

If you are a person with a disability who needs any accommodation in order to participate in this proceeding, you are entitled, at no cost to you, to the provision of certain assistance. Please contact the Sarasota County Jury Office, P.O. Box 3079, Sarasota, Florida 34230-3079, (941)861-7400, at least seven (7) days before your scheduled court appearance, or immediately upon receiving this notification if the time before the scheduled appearance is less than seven (7) days; if you are hearing or voice impaired, call 711.

ATTORNEY FOR PLAINTIFF
By /S/ Josh D. Donnelly
Josh D. Donnelly
Florida Bar #64788

Date: 05/22/2014
THIS INSTRUMENT PREPARED BY:
Law Offices Of Daniel C. Consuegra
9204 King Palm Drive
Tampa, FL 33619-1328
Phone: 813-915-8660
Attorneys for Plaintiff
129418
May 30; June 6, 2014 14-02381S

FIRST INSERTION

NOTICE OF SALE
IN THE CIRCUIT COURT OF THE
TWELFTH JUDICIAL CIRCUIT, IN
AND FOR SARASOTA COUNTY,
FLORIDA

GENERAL JURISDICTION
DIVISION
Case No. 58-2008-CA-013659
HSBC BANK USA, NATIONAL
ASSOCIATION, AS TRUSTEE FOR
THE HOLDER DEUTSCHE ALT-B
SECURITIES MORTGAGE LOAN
TRUST, SERIES 2006-AB1;
Plaintiff, vs.
ARLENE SUPNICK, ET.AL;
Defendants
NOTICE IS GIVEN that, in accordance with the Order to Reschedule Foreclosure Sale dated May 8, 2014, in the above-styled cause, The Clerk of Court will sell to the highest and best bidder for cash at www.sarasota.realforeclose.com, on June 12, 2014 at 9:00 am the following described property:

UNIT 221, THE PLAZA GARDENS, A CONDOMINIUM ACCORDING TO THE DECLARATION OF CONDOMINIUM RECORDED IN OFFICIAL RECORDS BOOK 1318, PAGES 376 THRU 424, INCLUSIVE, AND AMENDMENTS THERETO AND AS PER PLAT THEREOF RECORDED IN CONDOMINIUM BOOK 12, PAGES 50 AND 50A, OF THE PUBLIC RECORDS OF SARASOTA COUNTY, FLORIDA.

Property Address: 3700 SOUTH OSPREY AVENUE, SARASOTA, FL 34236

ANY PERSON CLAIMING AN INTEREST IN THE SURPLUS FROM THE SALE, IF ANY, OTHER THAN THE PROPERTY OWNER AS OF THE DATE OF THE LIS PENDENS MUST FILE A CLAIM WITHIN 60 DAYS AFTER THE SALE.

If you are a person with a disability who needs any accommodation in order to participate in this proceeding, you are entitled, at no cost to you, to the provision of certain assistance. Please contact the Sarasota County Jury Office, P.O. Box 3079, Sarasota, Florida 34230-3079, (941)861-7400, at least seven (7) days before your scheduled court appearance, or immediately upon receiving this notification if the time before the scheduled appearance is less than seven (7) days; if you are hearing or voice impaired, call 711.

WITNESS my hand on May 23, 2014.

By: Jessica M. Aldegue, Esq.
FBN. 100678

Attorneys for Plaintiff
Marinosci Law Group, P.C.
100 West Cypress Creek Road,
Suite 1045
Fort Lauderdale, FL 33309
Phone: (954)-644-8704;
Fax (954) 772-9601
ServiceFL@mlg-defaultlaw.com
ServiceFL2@mlg-defaultlaw.com
10-14505-1
May 30; June 6, 2014 14-02391S

FIRST INSERTION

NOTICE OF SALE
IN THE CIRCUIT COURT OF THE
TWELFTH JUDICIAL CIRCUIT
IN AND FOR SARASOTA COUNTY,
FLORIDA

Case No.: 58-2012-CA-005837 NC
CITIMORTGAGE, INC.
Plaintiff, v.
DANIEL MARTINEZ; DANIA
JIMENEZ; ANY AND ALL
UNKNOWN PARTIES CLAIMING
BY, THROUGH, UNDER, AND
AGAINST THE HEREIN NAMED
INDIVIDUAL DEFENDANT(S)
WHO ARE NOT KNOWN TO BE
DEAD OR ALIVE, WHETHER
SAID UNKNOWN PARTIES
MAY CLAIM AN INTEREST AS
SPOUSES, HEIRS, DEVISEES,
GRANTEES, OR OTHER
CLAIMANTS.
Defendant(s).

NOTICE IS HEREBY GIVEN pursuant to an Order of Uniform Final Judgment of Mortgage Foreclosure dated May 12, 2014, entered in Civil Case No. 58-2012-CA-005837 NC of the Circuit Court of the Twelfth Judicial Circuit in and for Sarasota County, Florida, wherein the Clerk of the Circuit Court will sell to the highest bidder for cash on the 16th day of June, 2014, at 9:00 a.m. online at the website: <https://www.sarasota.realforeclose.com>, relative to the following described property as set forth in the Final Judgment, to wit:

LOT 2301, SARASOTA SPRINGS, UNIT NO. 19 ACCORDING TO THE PLAT THEREOF AS RECORDED IN PLAT BOOK 9, PAGE 78, OF THE PUBLIC RECORDS OF SARASOTA COUNTY, FLORIDA.

Any person claiming an interest in the surplus from the sale, if any, other than the property owner as of the date of the Lis Pendens must file a claim within 60 days after the sale.

If you are a person with a disability who needs any accommodation in order to participate in this proceeding, you are entitled, at no cost to you, to the provision of certain assistance. Please contact the Sarasota County Jury Office, P.O. Box 3079, Sarasota, Florida 34230-3079, (941)861-7400, at least seven (7) days before your scheduled court appearance, or immediately upon receiving this notification if the time before the scheduled appearance is less than seven (7) days; if you are hearing or voice impaired, call 711.

MORRIS|HARDWICK|
SCHNEIDER, LLC
By: Susan Sparks, Esq.,
FBN: 33626
9409 Philadelphia Road
Baltimore, Maryland 21237

Mailing Address:
Morris|Hardwick|Schneider, LLC
5110 Eisenhower Blvd.,
Suite 302A
Tampa, Florida 33634
Customer Service (866)-503-4930
MHSinbox@closingsource.net
FL-97008072-10
10827857
May 30; June 6, 2014 14-02394S

FIRST INSERTION

NOTICE OF SALE
IN THE CIRCUIT COURT OF THE
TWELFTH JUDICIAL CIRCUIT
IN AND FOR SARASOTA COUNTY,
FLORIDA

Case No.: 58-2012-CA-003544 NC
CITIMORTGAGE, INC.
Plaintiff, v.
CONSTANCE S GALLUCCI;
JOSEPH J. GALLUCCI; ANY
AND ALL UNKNOWN PARTIES
CLAIMING BY, THROUGH,
UNDER, AND AGAINST THE
HEREIN NAMED INDIVIDUAL
DEFENDANT(S) WHO ARE
NOT KNOWN TO BE DEAD
OR ALIVE, WHETHER SAID
UNKNOWN PARTIES MAY CLAIM
AN INTEREST AS SPOUSES,
HEIRS, DEVISEES, GRANTEES,
OR OTHER CLAIMANTS;
MORTGAGE ELECTRONIC
REGISTRATION SYSTEMS, INC.
AS NOMINEE FOR CITIBANK,
FEDERAL SAVINGS BANK.
Defendant(s).

NOTICE IS HEREBY GIVEN pursuant to an Order of Uniform Final Judgment of Mortgage Foreclosure In Rem dated May 12, 2014, entered in Civil Case No. 58-2012-CA-003544 NC of the Circuit Court of the Twelfth Judicial Circuit in and for Sarasota County, Florida, wherein the Clerk of the Circuit Court will sell to the highest bidder for cash on the 16th day of June, 2014, at 9:00 a.m. online at the website: <https://www.sarasota.realforeclose.com>, relative to the following described property as set forth in the Final Judgment, to wit:

LOT 132, KENSINGTON PARK

SUBDIVISION, UNIT NO. 2, AS PER PLAT THEREOF RECORDED IN PLAT BOOK 9, PAGES 65 AND 65A, OF THE PUBLIC RECORDS OF SARASOTA COUNTY, FLORIDA.

Any person claiming an interest in the surplus from the sale, if any, other than the property owner as of the date of the Lis Pendens must file a claim within 60 days after the sale.

If you are a person with a disability who needs any accommodation in order to participate in this proceeding, you are entitled, at no cost to you, to the provision of certain assistance. Please contact the Sarasota County Jury Office, P.O. Box 3079, Sarasota, Florida 34230-3079, (941)861-7400, at least seven (7) days before your scheduled court appearance, or immediately upon receiving this notification if the time before the scheduled appearance is less than seven (7) days; if you are hearing or voice impaired, call 711.

MORRIS|HARDWICK|
SCHNEIDER, LLC
By: Susan Sparks, Esq.,
FBN: 33626
9409 Philadelphia Road
Baltimore, Maryland 21237

Mailing Address:
Morris|Hardwick|Schneider, LLC
5110 Eisenhower Blvd.,
Suite 302A
Tampa, Florida 33634
Customer Service (866)-503-4930
MHSinbox@closingsource.net
FL-97000370-12
10828063
May 30; June 6, 2014 14-02395S

FIRST INSERTION

NOTICE OF SALE
IN THE CIRCUIT COURT OF THE
TWELFTH JUDICIAL CIRCUIT
IN AND FOR SARASOTA COUNTY,
FLORIDA

CIVIL DIVISION
Case #: 2013-CA-001468-NC
Citibank, National Association, as
Trustee for WaMu Asset-Backed
Certificates WaMu Series 2007-HE3
Plaintiff, vs.-

Donnie R. Boyd a/k/a Donnie
Boyd and Katherine D. Boyd
a/k/a Katherine Boyd; Sarasota
County Health Department; Linda
S. Pearson; Unknown Parties in
Possession #1, If living, and all
Unknown Parties claiming by,
through, under and against the
above named Defendant(s) who
are not known to be dead or alive,
whether said Unknown Parties
may claim an interest as Spouse,
Heirs, Devisees, Grantees, or Other
Claimants; Unknown Parties in
Possession #2, If living, and all
Unknown Parties claiming by,
through, under and against the
above named Defendant(s) who
are not known to be dead or alive,
whether said Unknown Parties
may claim an interest as Spouse,
Heirs, Devisees, Grantees, or Other
Claimants
Defendant(s).

NOTICE IS HEREBY GIVEN pursuant to order rescheduling foreclosure sale or Final Judgment, entered in Civil Case No. 2013-CA-001468-NC of the Circuit Court of the 12th Judicial Circuit in and for Sarasota County, Florida, wherein Citibank, National Association, as Trustee for WaMu Asset-Backed Certificates WaMu Series 2007-HE3, Plaintiff and Donnie R. Boyd a/k/a Donnie Boyd and Katherine D. Boyd a/k/a Katherine Boyd are defendant(s), I, Clerk of Court, Karen E. Rushing, will sell to the highest and best bidder for cash VIA THE INTERNET AT WWW.SARASOTA.REALFORECLOSE.COM, AT 9:00 A.M. on June 16, 2014, the following described property as set forth in said Final Judgment, to-wit:

COMMENCE AT THE
NORTHWESTERLY CORNER OF LOT 1, BLOCK 7, PALMER FARMS, UNIT 3, ACCORDING TO THE PLAT THEREOF, AS RECORDED IN PLAT BOOK 3, PAGE 58 OF THE PUBLIC RECORDS OF SARASOTA COUNTY, FLORIDA; THENCE SOUTH 27°00'08" WEST, ALONG THE

EASTERLY RIGHT-OF-WAY OF GERRY ROAD (50 FEET WIDE), 1151.08 FEET TO THE POINT OF BEGINNING; THENCE CONTINUE SOUTH 27°00'08" WEST, ALONG SAID RIGHT-OF-WAY, 776.15 FEET; THENCE SOUTH 14°30'00" WEST, ALONG THE EASTERLY RIGHT-OF-WAY OF SAID GERRY ROAD, 200.00 FEET; THENCE EAST 262.60 FEET TO THE WESTERLY RIGHT-OF-WAY OF A 52 FOOT DRAINAGE CANAL RIGHT-OF-WAY, SHOWN ON SAID PLAT OF PALMER FARMS, UNIT 3; THENCE NORTHERLY AND NORTHEASTERLY ALONG SAID RIGHT-OF-WAY, 835.94 FEET TO A POINT; THENCE NORTH 57°06'30" WEST, 277.70 FEET TO THE POINT OF BEGINNING.
BEING A PART OF LOTS 4, 5 AND 6, BLOCK 7, PALMER FARMS, UNIT 3, ACCORDING TO THE PLAT THEREOF, AS RECORDED IN PLAT BOOK 3, PAGE 58, OF THE PUBLIC RECORDS OF SARASOTA COUNTY, FLORIDA.

ANY PERSON CLAIMING AN INTEREST IN THE SURPLUS FROM THE SALE, IF ANY, OTHER THAN THE PROPERTY OWNER AS OF THE DATE OF THE LIS PENDENS MUST FILE A CLAIM WITHIN 60 DAYS AFTER THE SALE.

If you are a person with a disability who needs any accommodation in order to participate in this proceeding, you are entitled, at no cost to you, to the provision of certain assistance. Please contact the Sarasota County Jury Office, P.O. Box 3079, Sarasota, Florida 34230-3079, (941)861-7400, at least seven (7) days before your scheduled court appearance, or immediately upon receiving this notification if the time before the scheduled appearance is less than seven (7) days; if you are hearing or voice impaired, call 711.

Submitted By:
ATTORNEY FOR PLAINTIFF:
SHAPIRO, FISHMAN
& GACHÉ, LLP
2424 North Federal Highway,
Suite 360
Boca Raton, Florida 33431
(561) 998-6700
(561) 998-6707
11-231307 FC01 SPS
May 30; June 6, 2014 14-02400S

FIRST INSERTION

NOTICE OF SALE
IN THE CIRCUIT COURT OF THE
TWELFTH JUDICIAL CIRCUIT
IN AND FOR SARASOTA COUNTY,
FLORIDA

CIVIL DIVISION
Case #: 2013-CA-003073-NC
DIVISION: C

U.S. Bank National Association,
as Trustee, successor in interest
to Bank of America, National
Association as Trustee as successor
by merger to LaSalle Bank National
Association, as Trustee for
Certificateholders of Bear Stearns
Asset Backed Securities I LLC,
Asset Backed-Certificates, Series
2006-HE1
Plaintiff, vs.-
Bridget Rene Spence a/k/a Bridget
Rene Tucker a/k/a Bridget Spence;
Rodney Spence; OSI Collection
Services, Inc. d/b/a Herring
Financial Services; The Hideaway
Condominium Association, Inc.;
Unknown Parties in Possession
#1, If living, and all Unknown
Parties claiming by, through, under
and against the above named
Defendant(s) who are not known
to be dead or alive, whether said
Unknown Parties may claim an
interest as Spouse, Heirs, Devisees,
Grantees, or Other Claimants;
Unknown Parties in Possession
#2, If living, and all Unknown
Parties claiming by, through, under
and against the above named
Defendant(s) who are not known
to be dead or alive, whether said
Unknown Parties may claim an
interest as Spouse, Heirs, Devisees,
Grantees, or Other Claimants
Defendant(s).

NOTICE IS HEREBY GIVEN pursuant to order rescheduling foreclosure sale or Final Judgment, entered in Civil Case No. 2013-CA-003073-NC of the Circuit Court of the 12th Judicial Circuit in and for Sarasota County, Florida, wherein U.S. Bank National Association, as Trustee, successor in interest to Bank of America, National Association as Trustee as successor by merger to LaSalle Bank National Association, as Trustee for Certificateholders of Bear Stearns Asset Backed Securities I LLC, Asset Backed-Certificates, Series 2006-HE1, Plaintiff and Bridget Rene Spence a/k/a Bridget Rene Tucker a/k/a Bridget Spence are defendant(s), I, Clerk of Court, Karen E. Rushing, will sell to the highest and best bidder for cash VIA THE

INTERNET AT WWW.SARASOTA.REALFORECLOSE.COM, AT 9:00 A.M. on June 18, 2014, the following described property as set forth in said Final Judgment, to-wit:

CONDOMINIUM UNIT NO. 313, BROOKSIDE CONDOMINIUM, PHASE I, A CONDOMINIUM A/K/A THE HIDEAWAY, A CONDOMINIUM, ACCORDING TO THE DECLARATION OF CONDOMINIUM THEREOF, AS RECORDED IN OFFICIAL RECORDS BOOK 1379, AT PAGE 1649, AS AMENDED IN OFFICIAL RECORDS BOOK 1545, AT PAGE 1302, AND ANY ADDITIONAL AMENDMENTS THERETO, AND ACCORDING TO THE PLAT THEREOF, AS RECORDED IN CONDOMINIUM BOOK 14, PAGES 36 THROUGH 36E, INCLUSIVE, ALL BEING OF THE PUBLIC RECORDS OF SARASOTA COUNTY, FLORIDA, TOGETHER WITH AN UNDIVIDED INTEREST IN THE COMMON ELEMENTS APPURTENANT THERETO.

ANY PERSON CLAIMING AN INTEREST IN THE SURPLUS FROM THE SALE, IF ANY, OTHER THAN THE PROPERTY OWNER AS OF THE DATE OF THE LIS PENDENS MUST FILE A CLAIM WITHIN 60 DAYS AFTER THE SALE.

If you are a person with a disability who needs any accommodation in order to participate in this proceeding, you are entitled, at no cost to you, to the provision of certain assistance. Please contact the Sarasota County Jury Office, P.O. Box 3079, Sarasota, Florida 34230-3079, (941)861-7400, at least seven (7) days before your scheduled court appearance, or immediately upon receiving this notification if the time before the scheduled appearance is less than seven (7) days; if you are hearing or voice impaired, call 711.

Submitted By:
ATTORNEY FOR PLAINTIFF:
SHAPIRO, FISHMAN
& GACHÉ, LLP
2424 North Federal Highway,
Suite 360
Boca Raton, Florida 33431
(561) 998-6700
(561) 998-6707
10-195833 FC01 SPS
May 30; June 6, 2014 14-02405S

FIRST INSERTION

NOTICE OF SALE
IN THE CIRCUIT COURT OF THE
TWELFTH JUDICIAL CIRCUIT OF
THE STATE OF FLORIDA, IN AND
FOR SARASOTA COUNTY
CIVIL DIVISION

Case No. 58-2012-CA-001871-0000-NC
DEUTSCHE BANK NATIONAL
TRUST COMPANY ON
BEHALF OF FINANCIAL
ASSET SECURITIES CORP.,
SOUNDVIEW HOME LOAN
TRUST 2007-WMCI, ASSET
BACKED CERTIFICATES, SERIES
2007-WMCI,
Plaintiff, vs.
JOSEPH C. JEAN-CHARLES;
UNKNOWN SPOUSE OF
JOSEPH C. JEAN-CHARLES;
ALEXANDRA JEAN-CHARLES;
UNKNOWN SPOUSE OF
ALEXANDRA JEAN-CHARLES;
IF LIVING, INCLUDING ANY
UNKNOWN SPOUSE OF SAID
DEFENDANT(S), IF REMARRIED,
AND IF DECEASED, THE
RESPECTIVE UNKNOWN
HEIRS, DEVISEES, GRANTEES,
ASSIGNEES, CREDITORS,
LIENORS, AND TRUSTEES, AND
ALL OTHER PERSONS CLAIMING
BY, THROUGH, UNDER
OR AGAINST THE NAMED
DEFENDANT(S); MORTGAGE
ELECTRONIC REGISTRATION
SYSTEMS, INC. ACTING SOLELY
AS A NOMINEE FOR WMC
MORTGAGE CORP.; WHETHER
DISSOLVED OR PRESENTLY
EXISTING, TOGETHER WITH
ANY GRANTEES, ASSIGNEES,
CREDITORS, LIENORS,
OR TRUSTEES OF SAID
DEFENDANT(S) AND ALL
OTHER PERSONS CLAIMING BY,
THROUGH, WHETHER UNDER,
OR AGAINST DEFENDANT(S);
UNKNOWN TENANT #1;
UNKNOWN TENANT #2;
Defendant(s)

Notice is hereby given that, pursuant to a Final Summary Judgment of Foreclosure entered on 05/12/2014

in the above-styled cause, in the Circuit Court of Sarasota County, Florida, the office of Karen E. Rushing clerk of the circuit court will sell the property situate in Sarasota County, Florida, described as:

LOT 2, BLOCK 233, PORT CHARLOTTE SUBDIVISION, A SUBDIVISION ACCORDING TO THE PLAT OR MAP THEREOF DESCRIBED IN PLAT BOOK 12, AT PAGE 20, AND 20A THRU 20Z OF THE PUBLIC RECORDS OF SARASOTA COUNTY, FLORIDA.

at public sale, to the highest and best bidder, for cash, www.sarasota.realforeclose.com at 9:00 o'clock, A.M., on June 17, 2014

Any person claiming an interest in the surplus from the sale, if any, other than the property owner as of the date of the lis pendens, must file a claim within 60 days after the sale.

If you are a person with a disability who needs any accommodation in order to participate in this proceeding, you are entitled, at no cost to you, to the provision of certain assistance. Please contact the Sarasota County Jury Office, P.O. Box 3079, Sarasota, Florida 34230-3079, (941)861-7400, at least seven (7) days before your scheduled court appearance, or immediately upon receiving this notification if the time before the scheduled appearance is less than seven (7) days; if you are hearing or voice impaired, call 711.

ATTORNEY FOR PLAINTIFF
By /S/ Josh D. Donnelly
Josh D. Donnelly
Florida Bar #64788

Date: 05/23/2014
THIS INSTRUMENT PREPARED BY:
Law Offices Of Daniel C. Consuegra
9204 King Palm Drive
Tampa, FL 33619-1328
Phone: 813-915-8660
Attorneys for Plaintiff
107440-T
May 30; June 6, 2014 14-02417S

**PUBLISH YOUR
LEGAL NOTICES
IN THE BUSINESS OBSERVER**
(813) 221-9505 Hillsborough, Pasco
(727) 447-7784 Pinellas
(941) 906-9386 Manatee, Sarasota, Lee
(239) 263-0122 Collier
(941) 249-4900 Charlotte
(407) 654-5500 Orange

FIRST INSERTION

NOTICE OF SALE IN THE CIRCUIT COURT OF THE TWELFTH JUDICIAL CIRCUIT IN AND FOR SARASOTA COUNTY, FLORIDA
CIVIL DIVISION
Case #: 2011-CA-007621-NC
DIVISION: A

Bank of America, National Association
Plaintiff, vs.-
Barry J. Rossheim and Shala A. Rossheim, Husband and Wife; Bank of America, National Association; Venice Palms Homeowners Association, Inc.
Defendant(s).

NOTICE IS HEREBY GIVEN pursuant to order resccheduling foreclosure sale or Final Judgment, entered in Civil Case No. 2011-CA-007621-NC of the Circuit Court of the 12th Judicial Circuit in and for Sarasota County, Florida, wherein Bank of America, National Association, Plaintiff and Barry J. Rossheim and Shala A. Rossheim, Husband and Wife are defendant(s), I, Clerk of Court, Karen E. Rushing, will sell to the highest and best bidder for cash VIA THE INTERNET AT WWW.SARASOTA.REALFORECLOSE.COM , AT 9:00 A.M. on June 16, 2014, the following described property as set forth in said Final Judgment, to-wit:

LOT 175, VENICE PALMS PHASE 1, AS PER PLAT RECORDED IN PLAT BOOK 40, PAGES 7, 7A THROUGH 7C, INCLUSIVE, OF THE PUBLIC RECORDS OF SARASOTA COUNTY, FLORIDA

ANY PERSON CLAIMING AN INTEREST IN THE SURPLUS FROM THE SALE, IF ANY, OTHER THAN THE PROPERTY OWNER AS OF THE DATE OF THE LIS PENDENS MUST FILE A CLAIM WITHIN 60 DAYS AFTER THE SALE.

If you are a person with a disability who needs any accommodation in order to participate in this proceeding, you are entitled, at no cost to you, to the provision of certain assistance. Please contact the Sarasota County Jury Office, P.O. Box 3079, Sarasota, Florida 34230-3079, (941)861-7400, at least seven (7) days before your scheduled court appearance, or immediately upon receiving this notification if the time before the scheduled appearance is less than seven (7) days; if you are hearing or voice impaired, call 711.

Submitted By:
ATTORNEY FOR PLAINTIFF:
SHAPIRO, FISHMAN & GACHÉ, LLP
2424 North Federal Highway, Suite 360
Boca Raton, Florida 33431
(561) 998-6700
(561) 998-6707
11-225129 FC01 CWF
May 30; June 6, 2014 14-02399S

FIRST INSERTION

NOTICE OF RESCHEDULED FORECLOSURE SALE IN THE CIRCUIT COURT OF THE TWELFTH JUDICIAL CIRCUIT IN AND FOR SARASOTA COUNTY, FLORIDA
CIVIL ACTION
Case No.: 2010-CA-008675-NC
DIVISION: A

THE BANK OF NEW YORK MELLON FKA THE BANK OF NEW YORK AS TRUSTEE FOR HOLDERS OF STRUCTURED ASSET MORTGAGE INVESTMENTS II TRUST 2006-AR8, MORTGAGE PASS-THROUGH CERTIFICATES, SERIES 2006-AR8,
Plaintiff, vs.
EVA DANIEL, et al,
Defendant(s).

NOTICE IS HEREBY GIVEN pursuant to an Order Rescheduling Foreclosure Sale dated May 21, 2014 and entered in Case No. 2010-CA-008675-NC of the Circuit Court of the TWELFTH Judicial Circuit in and for SARASOTA County, Florida wherein THE BANK OF NEW YORK MELLON FKA THE BANK OF NEW YORK AS TRUSTEE FOR THE STRUCTURED ASSET MORTGAGE INVESTMENTS II TRUST, MORTGAGE PASS-THROUGH CERTIFICATES, SERIES 2006-AR8, Plaintiff name has changed pursuant to order previously entered, is the Plaintiff and EVA DANIEL, THE UNKNOWN SPOUSE OF EVA DANIEL, ANY AND ALL UNKNOWN PARTIES CLAIMING BY, THROUGH, UNDER, AND AGAINST THE HEREIN NAMED INDIVIDUAL DEFENDANT(S) WHO ARE NOT KNOWN TO BE DEAD OR ALIVE, WHETHER SAID UNKNOWN PARTIES MAY CLAIM AN INTEREST AS SPOUSE, HEIRS, DEVISEES, GRANTEEES, OR OTHER CLAIMANTS; BANK OF AMERICA, NA; CACH, LLC; WHITE SANDS VILLAGE CONDOMINIUM ASSOCIATION, INC.; TENANT #1; TENANT #2 are the Defendants. The Clerk will sell to the highest and best bidder for cash at WWW.SARASOTA.REAL-

FIRST INSERTION

NOTICE OF FORECLOSURE SALE IN THE CIRCUIT COURT OF THE TWELFTH JUDICIAL CIRCUIT, IN AND FOR SARASOTA COUNTY, FLORIDA
CIVIL DIVISION
CASE NO.: 2012 CA 009662 NC
CITIMORTGAGE, INC.
Plaintiff, vs.
ROCCO BERARDI, et al
Defendants.

NOTICE IS HEREBY GIVEN pursuant to a Summary Final Judgment of foreclosure dated May 19, 2014, and entered in Case No. 2012 CA 009662 NC of the Circuit Court of the TWELFTH Judicial Circuit in and for SARASOTA COUNTY, Florida, wherein CITIMORTGAGE, INC., is Plaintiff, and ROCCO BERARDI, et al are Defendants, the clerk will sell to the highest and best bidder for cash, beginning at 09:00 AM at www.sarasota.realforeclose.com, in accordance with Chapter 45, Florida Statutes, on the 03 day of July, 2014, the following described property as set forth in said Summary Final Judgment, to wit:

Unit 107, Building 2, SERENADE ON PALMER RANCH CONDOMINIUM, a Condominium according to the Declaration of Condominium recorded in Instrument #2005045834, as amended from time to time, of the Public Records of Sarasota County, Florida.

Any person claiming an interest in the surplus funds from the sale, if any, other than the property owner as of the date of the lis pendens must file a claim within 60 days after the sale.

If you are a person with a disability who needs any accommodation in order to participate in this proceeding, you are entitled, at no cost to you, to the provision of certain assistance. Please contact the Sarasota County Jury Office, P.O. Box 3079, Sarasota, Florida 34230-3079, (941)861-7400, at least seven (7) days before your scheduled court appearance, or immediately upon receiving this notification if the time before the scheduled appearance is less than seven (7) days; if you are hearing or voice impaired, call 711.

Dated: May 22, 2014

By: /s/ Heather Griffiths
Phelan Hallinan, PLC
Heather Griffiths, Esq.,
Florida Bar No. 0091444
Emilio R. Lenzi, Esq.,
Florida Bar No. 0668273
Phelan Hallinan, PLC
Attorneys for Plaintiff
2727 West Cypress Creek Road
Ft. Lauderdale, FL 33309
Tel: 954-462-7000
Fax: 954-462-7001
Service by email:
FL.Service@PhelanHallinan.com
May 30; June 6, 2014 14-02397S

FIRST INSERTION

FORECLOSE.COM at 9:00AM, on 06/27/2014, the following described property as set forth in said Final Judgment:

UNIT 1020, WHITE SANDS VILLAGE, A CONDOMINIUM ACCORDING TO THE DECLARATION OF CONDOMINIUM RECORDED IN O. R. BOOK 1223, PAGE 1202, AS AMENDED, AND ACCORDING TO THE PLAT THEREOF RECORDED IN CONDOMINIUM BOOK 10, PAGE 33, AS AMENDED, OF THE PUBLIC RECORDS OF SARASOTA COUNTY, FLORIDA.

TOGETHER WITH AN UNDIVIDED INTEREST IN THE COMMON ELEMENTS APPURTENANT THERETO AS SET FORTH IN SAID DECLARATION

A/K/A 5637 MIDNIGHT PASS ROAD #1020, SARASOTA, FL 34242

Any person claiming an interest in the surplus from the sale, if any, other than the property owner as of the date of the Lis Pendens must file a claim within sixty (60) days after the sale.

If you are a person with a disability who needs any accommodation in order to participate in this proceeding, you are entitled, at no cost to you, to the provision of certain assistance. Please contact the Sarasota County Jury Office, P.O. Box 3079, Sarasota, Florida 34230-3079, (941)861-7400, at least seven (7) days before your scheduled court appearance, or immediately upon receiving this notification if the time before the scheduled appearance is less than seven (7) days; if you are hearing or voice impaired, call 711.

By: Lisa M. Lewis
Florida Bar No. 0086178
Ronald R Wolfe & Associates, P.L.
P.O. Box 25018
Tampa, Florida 33622-5018
(813) 251-4766
(813) 251-1541 Fax
F10039477
May 30; June 6, 2014 14-02442S

FIRST INSERTION

NOTICE OF FORECLOSURE SALE PURSUANT TO CHAPTER 45 IN THE CIRCUIT COURT OF THE TWELFTH JUDICIAL CIRCUIT IN AND FOR SARASOTA COUNTY, FLORIDA

CASE NO. 2012 CA 007556 NC
U.S. BANK NATIONAL ASSOCIATION, AS TRUSTEE FOR J.P. MORGAN MORTGAGE ACQUISITION TRUST 2006-CH1, ASSET BACKED PASS-THROUGH CERTIFICATES, SERIES 2006-CH1,
Plaintiff(s), vs.
ANTHONY MARTINI; et al.,
Defendant(s).

NOTICE IS HEREBY GIVEN that Sale will be made pursuant to an Order or Final Summary Judgment. Final Judgment was awarded on April 28, 2014 in Civil Case No.: 2012 CA 007556 NC, of the Circuit Court of the TWELFTH Judicial Circuit in and for SARASOTA County, Florida, wherein, U.S. BANK NATIONAL ASSOCIATION, AS TRUSTEE FOR J.P. MORGAN MORTGAGE ACQUISITION TRUST 2006-CH1, ASSET BACKED PASS-THROUGH CERTIFICATES, SERIES 2006-CH1, is the Plaintiff, and, ANTHONY MARTINI; FRANK CLEMENTS; UNKNOWN SPOUSE OF ANTHONY MARTINI; UNKNOWN SPOUSE OF FRANK CLEMENTS; CHASE BANK USA, N.A.; AND UNKNOWN TENANT(S) IN POSSESSION are Defendants.

The clerk of the court, Karen E. Rushing, will sell to the highest bidder for cash online at www.sarasota.realforeclose.com at 9:00 AM on June 12, 2014, the following described real property as set forth in said Final sum-

mary Judgment, to wit:
LOT 34, BLOCK 300, OF 5TH ADDITION TO PORT CHARLOTTE SUBDIVISION, A SUBDIVISION ACCORDING TO THE PLAT THEREOF, AS RECORDED IN PLAT BOOK 11, PAGE 33, OF THE PUBLIC RECORDS OF SARASOTA COUNTY, FLORIDA
ANY PERSON CLAIMING AN INTEREST IN THE SURPLUS FROM THE SALE, IF ANY, OTHER THAN THE PROPERTY OWNER AS OF THE DATE OF THE LIS PENDENS MUST FILE A CLAIM WITHIN 60 DAYS AFTER THE SALE.

If you are a person with a disability who needs any accommodation in order to participate in this proceeding, you are entitled, at no cost to you, to the provision of certain assistance. Please contact the Sarasota County Jury Office, P.O. Box 3079, Sarasota, Florida 34230-3079, (941)861-7400, at least seven (7) days before your scheduled court appearance, or immediately upon receiving this notification if the time before the scheduled appearance is less than seven (7) days; if you are hearing or voice impaired, call 711.

Dated this 27 day of MAY, 2014.
By: Nalini Singh
Fla. Bar #43700

Aldridge Connors, LLP
Attorney for Plaintiff(s)
1615 South Congress Avenue,
Suite 200
Delray Beach, FL 33445
Phone: 561.392.6391
Fax: 561.392.6965
Primary E-Mail:
ServiceMail@aclawllp.com
1012-1379B
May 30; June 6, 2014 14-02463S

FIRST INSERTION

NOTICE OF FORECLOSURE SALE IN THE CIRCUIT COURT OF THE TWELFTH JUDICIAL CIRCUIT IN AND FOR SARASOTA COUNTY, FLORIDA
GENERAL JURISDICTION DIVISION

CASE NO. 2009-CA-021609-NC
THE BANK OF NEW YORK MELLON F/K/A THE BANK OF NEW YORK AS SUCCESSOR TO JPMORGAN CHASE BANK, NATIONAL ASSOCIATION, AS TRUSTEE, C-BASS MORTGAGE LOAN ASSET-BACKED CERTIFICATES, SERIES 2004-CB8,
Plaintiff, vs.
DENNIS L. MYNATT; CAROL S. MYNATT; et al.
Defendant(s).

NOTICE IS HEREBY GIVEN pursuant to a Final Judgment of Foreclosure dated February 10, 2014, and entered in 2009-CA-021609-NC of the Circuit Court of the TWELFTH Judicial Circuit in and for Sarasota County, Florida, wherein THE BANK OF NEW YORK MELLON F/K/A THE BANK OF NEW YORK AS SUCCESSOR TO JPMORGAN CHASE BANK, NATIONAL ASSOCIATION, AS TRUSTEE, C-BASS MORTGAGE LOAN ASSET-BACKED CERTIFICATES, SERIES 2004-CB8 is the Plaintiff and DENNIS L. MYNATT; CAROL S. MYNATT; MORTGAGE ELECTRONIC REGISTRATION SYSTEMS, INC., AS NOMINEE FOR HOME LOAN CENTER, INC., D/B/A LENDING TREE LOANS are the Defendant(s). Karen Rushing as the Clerk of the

Circuit Court will sell to the highest and best bidder for cash at www.sarasota.realforeclose.com, at 09:00 AM, on June 10, 2014, the following described property as set forth in said Final Judgment, to wit:

LOT 41, COUNTRY WOOD ESTATES, UNIT 2, AS PER PLAT THEREOF, RECORDED IN PLAT BOOK 28, PAGES 6, 6A TO 6C OF THE PUBLIC RECORDS OF SARASOTA COUNTY, FLORIDA.

Any person claiming an interest in the surplus from the sale, if any, other than the property owner as of the date of the lis pendens must file a claim within 60 days after the sale.

If you are a person with a disability who needs any accommodation in order to participate in this proceeding, you are entitled, at no cost to you, to the provision of certain assistance. Please contact the Sarasota County Jury Office, P.O. Box 3079, Sarasota, Florida 34230-3079, (941)861-7400, at least seven (7) days before your scheduled court appearance, or immediately upon receiving this notification if the time before the scheduled appearance is less than seven (7) days; if you are hearing or voice impaired, call 711.

Dated this 22 day of May, 2014.
By: /s/ Philip Jones
Philip Jones
Florida Bar No.: 107721
Robertson, Anschutz & Schneid, PL
Attorneys for Plaintiff
6409 Congress Avenue, Suite 100
Boca Raton, Florida 33487
Florida Bar No.: 107721
13-15420
May 30; June 6, 2014 14-02437S

FIRST INSERTION

NOTICE OF SALE IN THE CIRCUIT COURT OF THE TWELFTH JUDICIAL CIRCUIT IN AND FOR SARASOTA COUNTY, FLORIDA
CIVIL DIVISION

Case #: 2013-CA-006516-NC
Green Tree Servicing LLC
Plaintiff, vs.-
Deanna J. Horn; Unknown Spouse of Deanna J. Horn; Unknown Parties in Possession #1, If living, and all Unknown Parties claiming by, through, under and against the above named Defendant(s) who are not known to be dead or alive, whether said Unknown Parties may claim an interest as Spouse, Heirs, Devisees, Grantees, or Other Claimants; Unknown Parties in Possession #2, If living, and all Unknown Parties claiming by, through, under and against the above named Defendant(s) who are not known to be dead or alive, whether said Unknown Parties may claim an interest as Spouse, Heirs, Devisees, Grantees, or Other Claimants
Defendant(s).

NOTICE IS HEREBY GIVEN pursuant to order resccheduling foreclosure sale or Final Judgment, entered in Civil Case No. 2013-CA-006516-NC of the Circuit Court of the 12th Judicial Circuit in and for Sarasota County, Florida, wherein Green Tree Servicing LLC, Plaintiff and Deanna J. Horn are defendant(s), I, Clerk of Court, Karen E. Rushing, will sell to the highest and best bidder for cash VIA THE INTERNET AT WWW.SARASOTA.REALFORECLOSE.COM , AT 9:00 A.M. on June 16,

2014, the following described property as set forth in said Final Judgment, to-wit:

LOTS 8108 & 8109, SOUTH VENICE, UNIT NO. 29, ACCORDING TO THE PLAT THEREOF, AS RECORDED IN PLAT BOOK 6, PAGE 82, OF THE PUBLIC RECORDS OF SARASOTA COUNTY, FLORIDA.

ANY PERSON CLAIMING AN INTEREST IN THE SURPLUS FROM THE SALE, IF ANY, OTHER THAN THE PROPERTY OWNER AS OF THE DATE OF THE LIS PENDENS MUST FILE A CLAIM WITHIN 60 DAYS AFTER THE SALE.

If you are a person with a disability who needs any accommodation in order to participate in this proceeding, you are entitled, at no cost to you, to the provision of certain assistance. Please contact the Sarasota County Jury Office, P.O. Box 3079, Sarasota, Florida 34230-3079, (941)861-7400, at least seven (7) days before your scheduled court appearance, or immediately upon receiving this notification if the time before the scheduled appearance is less than seven (7) days; if you are hearing or voice impaired, call 711.

Submitted By:
ATTORNEY FOR PLAINTIFF:
SHAPIRO, FISHMAN & GACHÉ, LLP
2424 North Federal Highway, Suite 360
Boca Raton, Florida 33431
(561) 998-6700
(561) 998-6707
13-261522 FC01 GRR
May 30; June 6, 2014 14-02401S

FIRST INSERTION

NOTICE OF SALE IN THE CIRCUIT COURT OF THE TWELFTH JUDICIAL CIRCUIT IN AND FOR SARASOTA COUNTY, FLORIDA
CIVIL ACTION

CASE NO.: 2008 CA 004452 NC
THE BANK OF NEW YORK MELLON F/K/A THE BANK OF NEW YORK, AS TRUSTEE FOR THE CERTIFICATEHOLDERS CWALT, INC. ALTERNATIVE LOAN TRUST 2005-56 MORTGAGE PASS-THROUGH CERTIFICATES, SERIES 2005-56,
Plaintiff vs.
MARILYN STRUBLE, et al.
Defendant(s)

Notice is hereby given that, pursuant to an In Rem Uniform Final Judgment of Foreclosure dated May 19, 2014 entered in Civil Case Number 2008 CA 004452 NC, in the Circuit Court for Sarasota County, Florida, wherein THE BANK OF NEW YORK MELLON F/K/A THE BANK OF NEW YORK, AS TRUSTEE FOR THE CERTIFICATEHOLDERS CWALT, INC. ALTERNATIVE LOAN TRUST 2005-56 MORTGAGE PASS-THROUGH CERTIFICATES, SERIES 2005-56 is the Plaintiff, and MARILYN STRUBLE, et al., are the Defendants, Sarasota County Clerk of Court will sell the property situated in Sarasota County, Florida, described as:

LOT 23, BEE RIDGE ESTATES, ACCORDING TO THE PLAT THEREOF RECORDED IN PLAT BOOK 10, PAGE 84, OF THE PUBLIC RECORDS OF SARASOTA COUNTY, FLORIDA.

DA.
at public sale, to the highest and best bidder, for cash, at www.sarasota.realforeclose.com at 09:00 AM, on the 25th day of June 2014. Any person claiming an interest in the surplus from the sale, if any, other than the property owner as of the date of the lis pendens must file a claim within 60 days after the sale.

If you are a person with a disability who needs any accommodation in order to participate in this proceeding, you are entitled, at no cost to you, to the provision of certain assistance. Please contact the Sarasota County Jury Office, P.O. Box 3079, Sarasota, Florida 34230-3079, (941)861-7400, at least seven (7) days before your scheduled court appearance, or immediately upon receiving this notification if the time before the scheduled appearance is less than seven (7) days; if you are hearing or voice impaired, call 711.

Dated: May 23, 2014
By: /s/ Josh Arthur
Josh Arthur, Esquire
(FBN 95506)
Michael Feiner, Esquire
(FBN 75051)
Boca Raton, FL 33431
(727) 446-4826
emailservice@ffapllc.com

FLORIDA FORECLOSURE ATTORNEYS, PLLC
4855 Technology Way,
Suite 500
Boca Raton, FL 33431
(727) 446-4826
emailservice@ffapllc.com
Our File No: CA11-01156 /JA
May 30; June 6, 2014 14-02432S

FIRST INSERTION

NOTICE OF SALE IN THE CIRCUIT COURT OF THE TWELFTH JUDICIAL CIRCUIT OF THE STATE OF FLORIDA, IN AND FOR SARASOTA COUNTY
CIVIL DIVISION
CASE NO.

58-2013-CA-005276-0000-NC
GREEN TREE SERVICING LLC,
Plaintiff, vs.

KEITH GOLDSTEIN A/K/A KEITH GOLDSTAIN; UNKNOWN SPOUSE OF KEITH GOLDSTEIN A/K/A KEITH GOLDSTAIN; MARILYN GOLDSTEIN A/K/A MARILYN GOLDSTAIN; UNKNOWN SPOUSE OF MARILYN GOLDSTEIN A/K/A MARILYN GOLDSTAIN; MORTGAGE ELECTRONIC REGISTRATION SYSTEMS, INC., AS NOMINEE FOR COUNTRYWIDE BANK, FSB; FULL SERVICE MEDIA, INC.; VENETIAN GOLF & RIVER CLUB PROPERTY OWNERS ASSOCIATION, INC.; UNKNOWN TENANT #1; UNKNOWN TENANT #2;
Defendant(s)

Notice is hereby given that, pursuant to a Final Summary Judgment of Foreclosure entered on 05/12/2014 in the above-styled cause, in the Circuit Court of Sarasota County, Florida, the office of Karen E. Rushing clerk of the circuit court will sell the property situate in Sarasota County, Florida, described as:
LOT 39, VENETIAN GOLF & RIVER CLUB PHASE 3C/D, ACCORDING TO THE PLAT

THEREOF, AS RECORDED IN PLAT BOOK 44, PAGE 37, OF THE PUBLIC RECORDS OF SARASOTA COUNTY, FLORIDA.

at public sale, to the highest and best bidder, for cash, www.sarasota.realforeclose.com at 9:00 o'clock, A.M., on June 17, 2014

Any person claiming an interest in the surplus from the sale, if any, other than the property owner as of the date of the lis pendens, must file a claim within 60 days after the sale.

If you are a person with a disability who needs any accommodation in order to participate in this proceeding, you are entitled, at no cost to you, to the provision of certain assistance. Please contact the Sarasota County Jury Office, P.O. Box 3079, Sarasota, Florida 34230-3079, (941)861-7400, at least seven (7) days before your scheduled court appearance, or immediately upon receiving this notification if the time before the scheduled appearance is less than seven (7) days; if you are hearing or voice impaired, call 711.

ATTORNEY FOR PLAINTIFF
By /S/ Josh D. Donnelly
Josh D. Donnelly
Florida Bar #64788

Date: 05/23/2014
THIS INSTRUMENT PREPARED BY:
Law Offices Of Daniel C. Consuegra
9204 King Palm Drive
Tampa, FL 33619-1328
Phone: 813-915-8660
Attorneys for Plaintiff
114924
May 30; June 6, 2014 14-02418S

FIRST INSERTION

NOTICE OF SALE IN THE CIRCUIT COURT OF THE TWELFTH JUDICIAL CIRCUIT IN AND FOR SARASOTA COUNTY, FLORIDA
CIVIL DIVISION
Case #: 2013-CA-001601-NC
DIVISION: C

JPMorgan Chase Bank, National Association
Plaintiff, vs.-
Gideon Rechnitz, Individually and as Trustee, of the Larkin Family Trust; Daniel W. Larkin; Unknown Parties in Possession #1, If living, and all Unknown Parties claiming by, through, under and against the above named Defendant(s) who are not known to be dead or alive, whether said Unknown Parties may claim an interest as Spouse, Heirs, Devisees, Grantees, or Other Claimants; Unknown Parties in Possession #2, If living, and all Unknown Parties claiming by, through, under and against the above named Defendant(s) who are not known to be dead or alive, whether said Unknown Parties may claim an interest as Spouse, Heirs, Devisees, Grantees, or Other Claimants
Defendant(s).

NOTICE IS HEREBY GIVEN pursuant to order resccheduling foreclosure sale or Final Judgment, entered in Civil Case No. 2013-CA-001601-NC of the Circuit Court of the 12th Judicial Circuit in and for Sarasota County, Florida, wherein JPMorgan Chase Bank, National Association, Plaintiff and Gideon Rechnitz, Individually and as Trustee, of the Larkin Family Trust are defendant(s), I, Clerk of Court, Karen E. Rushing, will sell to the highest and best bidder for cash VIA THE INTERNET AT WWW.SARASOTA.REALFORECLOSE.COM , AT 9:00 A.M. on June 17,

2014, the following described property as set forth in said Final Judgment, to-wit:

LOT 5, BLOCK 1932, 41ST ADDITION TO PORT CHARLOTTE SUBDIVISION, A SUBDIVISION, ACCORDING TO THE PLAT THEREOF, AS RECORDED IN PLAT BOOK 16, PAGES 42 AND 42A THROUGH 42F, OF THE PUBLIC RECORDS OF SARASOTA COUNTY, FLORIDA.

ANY PERSON CLAIMING AN INTEREST IN THE SURPLUS FROM THE SALE, IF ANY, OTHER THAN THE PROPERTY OWNER AS OF THE DATE OF THE LIS PENDENS MUST FILE A CLAIM WITHIN 60 DAYS AFTER THE SALE.

If you are a person with a disability who needs any accommodation in order to participate in this proceeding, you are entitled, at no cost to you, to the provision of certain assistance. Please contact the Sarasota County Jury Office, P.O. Box 3079, Sarasota, Florida 34230-3079, (941)861-7400, at least seven (7) days before your scheduled court appearance, or immediately upon receiving this notification if the time before the scheduled appearance is less than seven (7) days; if you are hearing or voice impaired, call 711.

Submitted By:
ATTORNEY FOR PLAINTIFF:
SHAPIRO, FISHMAN & GACHÉ, LLP
2424 North Federal Highway, Suite 360
Boca Raton, Florida 33431
(561) 998-6700
(561) 998-6707
11-216773 FC03 W50
May 30; June 6, 2014 14-02404S

HOW TO PUBLISH YOUR LEGAL NOTICE IN THE Business Observer

FOR MORE INFORMATION, CALL:
(813) 221-9505 Hillsborough, Pasco
(727) 447-7784 Pinellas
(941) 906-9386 Manatee, Sarasota, Lee
(239) 263-0122 Collier
(407) 654-5500 Orange
(941) 249-4900 Charlotte
Or e-mail: legal@businessobserver.com

FIRST INSERTION

NOTICE OF FORECLOSURE SALE IN THE CIRCUIT COURT OF THE TWELFTH JUDICIAL CIRCUIT IN AND FOR SARASOTA COUNTY, FLORIDA
GENERAL JURISDICTION DIVISION

CASE NO. 2010 CA 002256 NC
US BANK NATIONAL ASSOCIATION AS TRUSTEE, Plaintiff, vs. ANTHONY M. VEIGEL; et al. Defendant(s).

NOTICE IS HEREBY GIVEN pursuant to a Final Judgment of Mortgage Foreclosure dated November 19, 2013, and entered in 2010 CA 002256 NC of the Circuit Court of the TWELFTH Judicial Circuit in and for Sarasota County, Florida, wherein US BANK NATIONAL ASSOCIATION AS TRUSTEE is the Plaintiff and ANTHONY M. VEIGEL; PAULINE M. BRUNO; STATE OF FLORIDA DEPARTMENT OF REVENUE; KISHIA VEIGEL; UNKNOWN TENANT(S) are the Defendant(s). Karen Rushing as the Clerk of the Circuit Court will sell to the highest and best bidder for cash at www.sarasota.realforeclose.com, at 09:00 AM, on June 10, 2014, the following described property as set forth in said Final Judgment, to wit:

Lot 19, Block 372, Beach Manor #2, according to the plat thereof, as recorded in Plat Book 9, Page 90 of the Public Records of Sarasota County, Florida.

Any person claiming an interest in the surplus from the sale, if any, other than the property owner as of the date of the lis pendens must file a claim within 60 days after the sale.

If you are a person with a disability who needs any accommodation in order to participate in this proceeding, you are entitled, at no cost to you, to the provision of certain assistance. Please contact the Sarasota County Jury Office, P.O. Box 3079, Sarasota, Florida 34230-3079, (941)861-7400, at least seven (7) days before your scheduled court appearance, or immediately upon receiving this notification if the time before the scheduled appearance is less than seven (7) days; if you are hearing or voice impaired, call 711.

Dated this 22 day of May, 2014.

By: /s/ Philip Jones
Philip Jones
Florida Bar No.: 107721
Robertson, Anschutz & Schneid, PL Attorneys for Plaintiff
6409 Congress Avenue, Suite 100
Boca Raton, Florida 33487
Florida Bar No.: 107721
13-17715
May 30; June 6, 2014 14-02438S

FIRST INSERTION

NOTICE OF FORECLOSURE SALE IN THE CIRCUIT COURT OF THE TWELFTH JUDICIAL CIRCUIT IN AND FOR SARASOTA COUNTY, FLORIDA
CIVIL ACTION
CASE NO.: 58-2012-CA-005860 NC

DIVISION: C
WELLS FARGO BANK, NA, Plaintiff, vs. PATRICIA A. RARDIN, et al, Defendant(s).

NOTICE IS HEREBY GIVEN pursuant to a Final Judgment of Mortgage Foreclosure dated May 20, 2014 and entered in Case No. 58-2012-CA-005860 NC of the Circuit Court of the TWELFTH Judicial Circuit in and for SARASOTA County, Florida wherein WELLS FARGO BANK, NA is the Plaintiff and PATRICIA A RARDIN; THIRD FEDERAL SAVINGS AND LOAN ASSOCIATION OF CLEVELAND; are the Defendants, The Clerk will sell to the highest and best bidder for cash at WWW.SARASOTA.REALFORECLOSE.COM at 9:00AM, on the 19th day of August, 2014, the following described property as set forth in said Final Judgment:

LOT 624, KENSINGTON PARK, UNIT NO. 5, AS PER PLAT THEREOF RECORDED IN PLAT BOOK 11, PAGES 9 AND 9A, OF THE PUBLIC RECORDS OF SARASOTA COUNTY, FLORIDA.
A/K/A 3812 NOTTINGHAM DRIVE, SARASOTA, FL 34235-8044

Any person claiming an interest in the surplus from the sale, if any, other than the property owner as of the date of the Lis Pendens must file a claim within sixty (60) days after the sale.

If you are a person with a disability who needs any accommodation in order to participate in this proceeding, you are entitled, at no cost to you, to the provision of certain assistance. Please contact the Sarasota County Jury Office, P.O. Box 3079, Sarasota, Florida 34230-3079, (941)861-7400, at least seven (7) days before your scheduled court appearance, or immediately upon receiving this notification if the time before the scheduled appearance is less than seven (7) days; if you are hearing or voice impaired, call 711.

By: Amy Recla
Florida Bar No. 102811
Ronald R Wolfe & Associates, P.L.
P.O. Box 25018
Tampa, Florida 33622-5018
(813) 251-4766
(813) 251-1541 Fax
F12011066
May 30; June 6, 2014 14-02408S

FIRST INSERTION

NOTICE OF SALE UNDER F.S. CHAPTER 45
IN THE CIRCUIT COURT OF THE TWELFTH JUDICIAL CIRCUIT IN AND FOR SARASOTA COUNTY, FLORIDA
CASE NO. 2009-CA-003176-NC-C

HG RECOVERY FUND I, LLC, Plaintiff, vs. JIM TSIOGAS; JOHN A. MAGLIANO, JR. Defendant(s).

NOTICE IS GIVEN that, in accordance with the Final Judgment of Foreclosure dated October 17th, 2013 in the above styled cause, I will sell to the highest and best bidder for cash at www.sarasota.realforeclose.com at 9:00 a.m. on June 26, 2014, the following described property:

Property Address: SHRIMP LANE A/K/A STAGHORN LANE, NORTH PORT, FLORIDA 34287.

Legal Description: T R A C T H, BLOCK 666, 17TH ADDITION TO PORT CHARLOTTE SUBDIVISION, ACCORDING TO THE PLAT THEREOF RECORDED IN PLAT BOOK 13, PAGE 16, OF THE PUBLIC RECORDS OF SARASOTA COUNTY, FLORIDA.

This Notice of Sale will be published in the Business Observer by Assouline & Berlowe, P.A., 213 E. Sheridan Street, Suite 3, Dania Beach, FL 33004.

ANY PERSON CLAIMING AN INTEREST IN THE SURPLUS FROM THE SALE, IF ANY, OTHER THAN THE PROPERTY OWNER AS OF THE DATE OF THE LIS PENDENS MUST FILE A CLAIM WITHIN 60 DAYS AFTER THE SALE.

If you are a person with a disability who needs any accommodation in order to participate in this proceeding, you are entitled, at no cost to you, to the provision of certain assistance. Please contact the Sarasota County Jury Office, P.O. Box 3079, Sarasota, Florida 34230-3079, (941)861-7400, at least seven (7) days before your scheduled court appearance, or immediately upon receiving this notification if the time before the scheduled appearance is less than seven (7) days; if you are hearing or voice impaired, call 711.

BY: /s/ Pascale Achille
PASCALE ACHILLE, ESQ.
Florida Bar No. 0013403
ASSOULINE & BERLOWE, P.A.
Attorneys for Plaintiff
213 E. Sheridan Street,
Suite 3
Dania, FL 33004
(954)929-1899
(954)922-6662 fax
{00132931.DOCX.1}
May 30; June 6, 2014 14-02415S

FIRST INSERTION

NOTICE OF SALE
IN THE CIRCUIT COURT OF THE TWELFTH JUDICIAL CIRCUIT IN AND FOR SARASOTA COUNTY, FLORIDA,
CIVIL ACTION
CASE NO.: 2013 CA 004284 NC

LIBERTY SAVINGS BANK, FSB, Plaintiff vs. DAVID H. SOUCIE JR. , et al. Defendant(s)

Notice is hereby given that, pursuant to a Uniform Final Judgment of Mortgage Foreclosure dated May 19, 2014 entered in Civil Case Number 2013 CA 004284 NC, in the Circuit Court for Sarasota County, Florida, wherein LIBERTY SAVINGS BANK, FSB is the Plaintiff, and DAVID H. SOUCIE JR. , et al., are the Defendants, Sarasota County Clerk of Court will sell the property situated in Sarasota County, Florida, described as:

LOT 74, DESOTO PINES, UNIT II, ACCORDING TO THE PLAT THEREOF, AS RECORDED IN PLAT BOOK 29, PAGE 27, OF THE PUBLIC RECORDS OF SARASOTA COUNTY, FLORIDA.

at public sale, to the highest and best bidder, for cash, at www.sarasota.realforeclose.com at 09:00 AM, on the 23rd day of June, 2014. Any person claiming an interest in the surplus from the sale, if any, other than the property owner as of the date of the lis pendens must file a claim within 60 days after the sale.

If you are a person with a disability who needs any accommodation in order to participate in this proceeding, you are entitled, at no cost to you, to the provision of certain assistance. Please contact the Sarasota County Jury Office, P.O. Box 3079, Sarasota, Florida 34230-3079, (941)861-7400, at least seven (7) days before your scheduled court appearance, or immediately upon receiving this notification if the time before the scheduled appearance is less than seven (7) days; if you are hearing or voice impaired, call 711.

Dated: May 23, 2014
By: /S/ Michael Feiner
Josh Arthur, Esquire
(FBN 95506)
Michael Feiner, Esquire
(FBN 75051)
Mark Morales, Esquire
(FBN 64982)
4855 Technology Way, Suite 500
Boca Raton, FL 33431
(727) 446-4826
emailservice@ffapllc.com

FLORIDA FORECLOSURE ATTORNEYS, PLLC
4855 Technology Way, Suite 500
Boca Raton, FL 33431
(727) 446-4826
emailservice@ffapllc.com
Our File No: CA13-02514 /JA
May 30; June 6, 2014 14-02431S

FIRST INSERTION

NOTICE OF SALE
IN THE CIRCUIT COURT OF THE TWELFTH JUDICIAL CIRCUIT IN AND FOR SARASOTA COUNTY, FLORIDA,
CIVIL ACTION
CASE NO.: 2013 CA 003998 NC

FIFTH THIRD MORTGAGE COMPANY, Plaintiff vs. MICHAEL MILELLA, et al. Defendant(s)

Notice is hereby given that, pursuant to a Uniform Final Judgment of Mortgage Foreclosure dated May 19, 2014 entered in Civil Case Number 2013 CA 003998 NC, in the Circuit Court for Sarasota County, Florida, wherein FIFTH THIRD MORTGAGE COMPANY is the Plaintiff, and MICHAEL MILELLA, et al., are the Defendants, Sarasota County Clerk of Court will sell the property situated in Sarasota County, Florida, described as:

LOT 25, BLOCK 103, 7TH ADDITION TO PORT CHARLOTTE SUBDIVISION, ACCORDING TO THE PLAT THEREOF RECORDED IN PLAT BOOK 12, PAGE 19, OF THE PUBLIC RECORDS OF SARASOTA COUNTY, FLORIDA.

at public sale, to the highest and best bidder, for cash, at www.sarasota.realforeclose.com at 09:00 AM, on the 23rd day of June, 2014. Any person claiming an interest in the surplus from the sale, if any, other than the property owner as of the date of the lis pendens must file a claim within 60 days after the sale.

If you are a person with a disability who needs any accommodation in order to participate in this proceeding, you are entitled, at no cost to you, to the provision of certain assistance. Please contact the Sarasota County Jury Office, P.O. Box 3079, Sarasota, Florida 34230-3079, (941)861-7400, at least seven (7) days before your scheduled court appearance, or immediately upon receiving this notification if the time before the scheduled appearance is less than seven (7) days; if you are hearing or voice impaired, call 711.

Dated: May 23, 2014
By: /S/ Michael Feiner
Michael Feiner, Esquire
(FBN 75051)
Mark Morales, Esquire
(FBN 64982)
Marissa M. Yaker, Esquire
(FBN 103591)
4855 Technology Way, Suite 500
Boca Raton, FL 33431
(727) 446-4826
emailservice@ffapllc.com

FLORIDA FORECLOSURE ATTORNEYS, PLLC
4855 Technology Way, Suite 500
Boca Raton, FL 33431
(727) 446-4826
emailservice@ffapllc.com
Our File No: CA13-01987 /JA
May 30; June 6, 2014 14-02430S

FIRST INSERTION

NOTICE OF SALE
IN THE CIRCUIT COURT OF THE TWELFTH JUDICIAL CIRCUIT IN AND FOR SARASOTA COUNTY, FLORIDA
Case No.: 2011 CA 004659 NC

CITIMORTGAGE, INC. Plaintiff, v. KIM A. BROOKS AKA KIM A. BROOKS-GUZZO; BRIAN L. GUZZO; ANY AND ALL UNKNOWN PARTIES CLAIMING BY, THROUGH, UNDER, AND AGAINST THE HEREIN NAMED INDIVIDUAL DEFENDANT(S) WHO ARE NOT KNOWN TO BE DEAD OR ALIVE, WHETHER SAID UNKNOWN PARTIES MAY CLAIM AN INTEREST AS SPOUSES, HEIRS, DEVISEES, GRANTEEES, OR OTHER CLAIMANTS.

Defendant(s) NOTICE IS HEREBY GIVEN pursuant to an Order Granting Plaintiff's Motion to Reset Foreclosure Sale dated May 8, 2014, entered in Civil Case No. 2011 CA 004659 NC of the Circuit Court of the Twelfth Judicial Circuit in and for Sarasota County, Florida, wherein the Clerk of the Circuit Court will sell to the highest bidder for cash on the 19th day of June, 2014, at 9:00 a.m. online at the website: https://www.sarasota.realforeclose.com, relative to the following described property as set forth in the Final Judgment, to wit:

LOT 15, BLOCK 549, 18TH ADDITION TO PORT CHARLOTTE SUBDIVISION, ACCORDING TO THE PLAT THEREOF, AS RECORDED IN PLAT BOOK 14 AT PAGES 6, 6A THROUGH 6V, IN THE PUBLIC RECORDS OF SARASOTA COUNTY, FLORIDA.

Any person claiming an interest in the surplus from the sale, if any, other than the property owner as of the date of the Lis Pendens must file a claim within 60 days after the sale.

If you are a person with a disability who needs any accommodation in order to participate in this proceeding, you are entitled, at no cost to you, to the provision of certain assistance. Please contact the Sarasota County Jury Office, P.O. Box 3079, Sarasota, Florida 34230-3079, (941)861-7400, at least seven (7) days before your scheduled court appearance, or immediately upon receiving this notification if the time before the scheduled appearance is less than seven (7) days; if you are hearing or voice impaired, call 711.

Susan Sparks, Esq., FBN: 33626
9409 Philadelphia Road
Baltimore, Maryland 21237
Morris|Hardwick|Schneider, LLC
5110 Eisenhower Blvd.,
Suite 302A
Tampa, Florida 33634
Customer Service (866)-503-4930
MHSinbox@closingsource.net
FL-97001089-11
10842280
May 30; June 6, 2014 14-02433S

FIRST INSERTION

NOTICE OF ACTION
IN THE CIRCUIT COURT OF THE TWELFTH JUDICIAL CIRCUIT IN AND FOR SARASOTA COUNTY, FLORIDA
CASE NO.: 2013 CA 003798 NC

FEDERAL NATIONAL MORTGAGE ASSOCIATION, Plaintiff, vs. THE ESTATE OF WILLIAM T. SHREVE, III, A/K/A WILLIAM THOMAS SHREVE, III, A/K/A WILLIAM T. SHREVE, DECEASED; LISA MICHELLE HARPER A/K/A LISA HARPER; JENNIFER L. SYDNOR; HEATHER ANN HARDIN A/K/A HEATHER A. HARDIN F/K/A HEATHER A. SHREVE; UNKNOWN HEIRS, BENEFICIARIES, DEVISEES, ASSIGNEES, LIENORS, CREDITORS, TRUSTEES AND ALL OTHERS WHO MAY CLAIM AN INTEREST IN THE ESTATE OF WILLIAM T. SHREVE, III, A/K/A WILLIAM THOMAS SHREVE, III, A/K/A WILLIAM T. SHREVE, DECEASED, UNKNOWN TENANT(S) IN POSSESSION # 1 and #2, et.al. Defendant(s).

TO: THE ESTATE OF WILLIAM T. SHREVE, III, A/K/A WILLIAM THOMAS SHREVE, III, A/K/A WILLIAM T. SHREVE, DECEASED (Last Known Address) 1503 OAK PARK AVE SARASOTA, FL 34237 UNKNOWN HEIRS, BENEFICIARIES, DEVISEES, ASSIGNEES, LIENORS, CREDITORS, TRUSTEES AND ALL OTHERS WHO MAY CLAIM AN INTEREST IN THE ESTATE OF WILLIAM T. SHREVE, III, A/K/A WILLIAM THOMAS SHREVE, III, A/K/A WILLIAM T. SHREVE, DECEASED (Last Known Address) 1503 OAK PARK AVE SARASOTA, FL 34237 (Current Residence Unknown) if living, and ALL OTHER UNKNOWN PARTIES, including, if a named Defendant is deceased, the personal representatives, the surviving spouse, heirs, devisees, grantees, creditors, and all other parties claiming, by through, under or against that Defendant, and all claimants, persons or parties, natural or corporate, or whose exact legal status is unknown, claiming under any of the above named or described Defendants

YOU ARE NOTIFIED that an action for Foreclosure of Mortgage on the following described property:

THE SOUTH 60 FEET OF LOTS 11 & 12, BLOCK D, REVISED PLAT OF OAK PARK, ACCORDING TO THE PLAT THEREOF RECORDED IN PLAT BOOK 1, PAGE 215, OF THE PUBLIC RECORDS OF SARASOTA COUNTY, FLORIDA.

A/K/A: 1503 OAK PARK AVE, SARASOTA, FL 34237.

has been filed against you and you are required to serve a copy of your written defenses, if any, to it on Brian L. Rosaler, Esquire, POPKIN & ROSALER, P.A., 1701 West Hillsboro Boulevard, Suite 400, Deerfield Beach, FL 33442., Attorney for Plaintiff, whose on or before June 30th, 2014, a date which is within thirty (30) days after the first publication of this Notice in the Business Observer and file the original with the Clerk of this Court either before service on Plaintiff's attorney or immediately thereafter; otherwise, a default will be entered against you for the relief demanded in the complaint.

If you cannot afford an attorney, contact Gulfoast Legal Services at 941-366-1746 or www.gulfoastlegal.org, or Legal Aid of Manasota at 941-366-0038 or www.legalaidofmanasota.org. If you do not qualify for free legal assistance or do not know an attorney, you may email an attorney referral service (listed in the phone book) or contact the Florida Bar Lawyer Referral Service at (800) 342-8011.

If you are a person with a disability who needs any accommodation in order to participate in this proceeding, you are entitled, at no cost to you, to the provision of certain assistance. Please contact the Sarasota County Jury Office, P.O. Box 3079, Sarasota, Florida 34230-3079, (941)861-7400, at least seven (7) days before your scheduled court appearance, or immediately upon receiving this notification if the time before the scheduled appearance is less than seven (7) days; if you are hearing or voice impaired, call 711.

WITNESS my hand and the seal of this Court this 21st day of May, 2014.

KAREN E. RUSHING
As Clerk of the Court
(SEAL) By L. Szymanski
As Deputy Clerk
Brian L. Rosaler, Esquire
POPKIN & ROSALER, P.A.,
1701 West Hillsboro Boulevard,
Suite 400,
Deerfield Beach, FL 33442
Attorney for Plaintiff
12-35214
May 30; June 6, 2014 14-02372S

FIRST INSERTION

NOTICE OF ACTION
IN THE CIRCUIT COURT OF THE TWELFTH JUDICIAL CIRCUIT, IN AND FOR SARASOTA COUNTY, FLORIDA

CASE NO.: 58-2014-CA-002438 NC
BANK OF AMERICA, N.A.; Plaintiff, vs.

UNKNOWN HEIRS, BENEFICIARIES, DEVISEES, ASSIGNEES, LIENORS, CREDITORS, TRUSTEES AND ALL OTHERS WHO MAY CLAIM AN INTEREST IN THE ESTATE OF KEITH KEPNER A/K/A KEITH W. KEPNER A/K/A KEITH WESLEY KEPNER, DECEASED; ANY AND ALL UNKNOWN PARTIES CLAIMING BY, THROUGH, UNDER AND AGAINST THE HEREIN NAMED INDIVIDUAL DEFENDANT(S) WHO ARE NOT KNOWN TO BE DEAD OR ALIVE, WHETHER SAID UNKNOWN PARTIES MAY CLAIM AN INTEREST AS SPOUSES, HEIRS, DEVISEES, GRANTEEES, OR OTHER CLAIMANTS; CITY OF SARASOTA, FLORIDA; CITY OF NORTH PORT FLORIDA; UNKNOWN TENANT #1 IN POSSESSION OF THE PROPERTY; UNKNOWN TENANT #2 IN POSSESSION OF THE PROPERTY; Defendants

To the following Defendant(s): UNKNOWN HEIRS, BENEFICIARIES, DEVISEES, ASSIGNEES, LIENORS, CREDITORS, TRUSTEES AND ALL OTHERS WHO MAY CLAIM AN INTEREST IN THE ESTATE OF KEITH KEPNER A/K/A KEITH W. KEPNER A/K/A KEITH WESLEY KEPNER, DECEASED
Last Known Address UNKNOWN
YOU ARE NOTIFIED that an action for Foreclosure of Mortgage on the following described property:

LOT 26, BLOCK 1923, OF 41 ST ADDITION TO PORT CHARLOTTE SUBDIVISION, AS PER PLAT THEREOF RECORDED IN PLAT BOOK 16,

PAGES 42, 42A THRU 42F, OF THE PUBLIC RECORDS OF SARASOTA COUNTY, FLORIDA.

a/k/a 4655 BULLARD STREET, NORTH PORT, FL 34287

has been filed against you and you are required to serve a copy of your written defenses, if any, to it, on Marinosci Law Group, P.C., Attorney for Plaintiff, whose address is 100 W. Cypress Creek Road, Suite 1045, Fort Lauderdale, Florida 33309, on or before 6-30-2014, a date which is within thirty (30) days after the first publication of this Notice in the BUSINESS OBSERVER, file the original with the Clerk of this Court either before service on Plaintiff's attorney, or immediately thereafter; otherwise a default will be entered against you for the relief demand in the complaint.

This notice is provided pursuant to Administrative Order No. 2.065.
If you are a person with a disability who needs any accommodation in order to participate in this proceeding, you are entitled, at no cost to you, to the provision of certain assistance. Please contact the Sarasota County Jury Office, P.O. Box 3079, Sarasota, Florida 34230-3079, (941)861-7400, at least seven (7) days before your scheduled court appearance, or immediately upon receiving this notification if the time before the scheduled appearance is less than seven (7) days; if you are hearing or voice impaired, call 711.

WITNESS my hand and the seal of this Court this 16 day of May, 2014.
KAREN E. RUSHING
As Clerk of the Court
(SEAL) By: G. Kopinsky
As Deputy Clerk
Marinosci Law Group, P.C.
100 W. Cypress Creek Road,
Suite 1045
Fort Lauderdale, FL 33309
Telephone: (954) 644-8704
Telefacsimile: (954) 772-9601
Our File Number: 14-03331
May 30; June 6, 2014 14-02350S

FIRST INSERTION

NOTICE OF SALE
IN THE CIRCUIT COURT OF THE TWELFTH JUDICIAL CIRCUIT OF THE STATE OF FLORIDA, IN AND FOR SARASOTA COUNTY
CIVIL DIVISION
CASE NO.

58-2012-CA-001860-XXXX-NC
THE BANK OF NEW YORK MELLON AS SUCCESSOR BY MERGER TO THE BANK OF NEW YORK, AS TRUSTEE FOR THE CERTIFICATEHOLDERS, CWABS, INC., ASSET-BACKED CERTIFICATES, SERIES 2006-BC5, Plaintiff, vs. DONALD L. BARNES; UNKNOWN SPOUSE OF DONALD L. BARNES; GLORIA J. BARNES; UNKNOWN SPOUSE OF GLORIA J. BARNES; IF LIVING, INCLUDING ANY UNKNOWN SPOUSE OF SAID DEFENDANT(S), IF REMARRIED, AND IF DECEASED, THE RESPECTIVE UNKNOWN HEIRS, DEVISEES, GRANTEEES, ASSIGNEES, CREDITORS, LIENORS, AND TRUSTEES, AND ALL OTHER PERSONS CLAIMING BY, THROUGH, UNDER OR AGAINST THE NAMED DEFENDANT(S); MORTGAGE ELECTRONIC REGISTRATION SYSTEMS, INC ACTING SOLELY AS A NOMINEE FOR BENEFICIAL FLORIDA INC.; STATE OF FLORIDA; CLERK OF THE CIRCUIT COURT OF SARASOTA COUNTY, FLORIDA; WHETHER DISSOLVED OR PRESENTLY EXISTING, TOGETHER WITH ANY GRANTEEES, ASSIGNEES, CREDITORS, LIENORS, OR TRUSTEES OF SAID DEFENDANT(S) AND ALL OTHER PERSONS CLAIMING BY, THROUGH, UNDER, OR AGAINST DEFENDANT(S); UNKNOWN TENANT #1; UNKNOWN TENANT #2; Defendant(s)

Notice is hereby given that, pursuant to a Final Summary Judgment of Foreclosure entered on 05/12/2014 in the above styled cause, in the Circuit Court of Sarasota County, Florida, the office of Karen E. Rushing clerk of the circuit court will sell the property situate in Sarasota County, Florida, described as:

LOT 504, DESOTO LAKES, UNIT 8, ACCORDING TO THE PLAT THEREOF, RECORDED IN PLAT BOOK 9, PAGE 13, OF THE PUBLIC RECORDS OF SARASOTA COUNTY, FLORIDA.

at public sale, to the highest and best bidder, for cash, www.sarasota.realforeclose.com at 9:00 o'clock, A.M., on June 17, 2014
Any person claiming an interest in the surplus from the sale, if any, other than the property owner as of the date of the lis pendens, must file a claim within 60 days after the sale.
If you are a person with a disability who needs any accommodation in order to participate in this proceeding, you are entitled, at no cost to you, to the provision of certain assistance. Please contact the Sarasota County Jury Office, P.O. Box 3079, Sarasota, Florida 34230-3079, (941)861-7400, at least seven (7) days before your scheduled court appearance, or immediately upon receiving this notification if the time before the scheduled appearance is less than seven (7) days; if you are hearing or voice impaired, call 711.

ATTORNEY FOR PLAINTIFF
By /S/ Josh D. Donnelly
Josh D. Donnelly
Florida Bar #64788
Date: 05/23/2014
THIS INSTRUMENT PREPARED BY:
Law Offices Of Daniel C. Consuegra
9204 King Palm Drive
Tampa, FL 33619-1328
Phone: 813-915-8660
Attorneys for Plaintiff
76167-T
May 30; June 6, 2014 14-02424S

HOW TO PUBLISH YOUR LEGAL NOTICE IN THE BUSINESS OBSERVER

FOR MORE INFORMATION, CALL:
(813) 221-9505 Hillsborough, Pasco
(727) 447-7784 Pinellas
(941) 906-9386 Manatee, Sarasota, Lee
Or e-mail: legal@businessobserverfl.com

(239) 263-0122 Collier
(407) 654-5500 Orange
(941) 249-4900 Charlotte

FIRST INSERTION

NOTICE OF SALE
IN THE CIRCUIT COURT OF THE
TWELFTH JUDICIAL CIRCUIT OF
THE STATE OF FLORIDA, IN AND
FOR SARASOTA COUNTY
CIVIL DIVISION
CASE NO.

58-2013-CA-003803-XXXX-NC
U.S. BANK TRUST, N.A., AS
TRUSTEE FOR LSF8 MASTER
PARTICIPATION TRUST, BY
CALIBER HOME LOANS, INC., AS
ITS ATTORNEY IN FACT,
Plaintiff, vs.

PAUL RATTRAY; UNKNOWN
SPOUSE OF PAUL RATTRAY;
HELENA RATTRAY; UNKNOWN
SPOUSE OF HELENA RATTRAY;
IF LIVING, INCLUDING ANY
UNKNOWN SPOUSE OF SAID
DEFENDANT(S), IF REMARRIED,
AND IF DECEASED, THE
RESPECTIVE UNKNOWN
HEIRS, DEVISEES, GRANTEEES,
ASSIGNEES, CREDITORS,
LIENORS, AND TRUSTEES, AND
ALL OTHER PERSONS CLAIMING
BY, THROUGH, UNDER
OR AGAINST THE NAMED
DEFENDANT(S); MORTGAGE
ELECTRONIC REGISTRATION
SYSTEMS, INC., AS NOMINEE
FOR SOLSTICE CAPITAL
GROUP, INC.; BENEFICIAL
FLORIDA, INC.; WHETHER
DISSOLVED OR PRESENTLY
EXISTING, TOGETHER WITH
ANY GRANTEEES, ASSIGNEES,
CREDITORS, LIENORS,
OR TRUSTEES OF SAID
DEFENDANT(S) AND ALL
OTHER PERSONS CLAIMING
BY, THROUGH, UNDER, OR
AGAINST DEFENDANT(S);
UNKNOWN TENANT #1;
UNKNOWN TENANT #2;
Defendant(s)

Notice is hereby given that, pursuant to a Final Summary Judgment of Foreclosure entered on 05/12/2014 in the above-styled cause, in the Circuit

Court of Sarasota County, Florida, the office of Karen E. Rushing clerk of the circuit court will sell the property situate in Sarasota County, Florida, described as:

LOT 25, BLOCK 1924, 41ST ADDITION TO PORT CHARLOTTE SUBDIVISION, ACCORDING TO THE PLAT THEREOF, AS RECORDED IN PLAT BOOK 16, PAGES 42, 42A - 42F, OF THE PUBLIC RECORDS OF SARASOTA COUNTY, FLORIDA.

at public sale, to the highest and best bidder, for cash, www.sarasota.real-foreclose.com at 9:00 o'clock, A.M., on June 17, 2014

Any person claiming an interest in the surplus from the sale, if any, other than the property owner as of the date of the lis pendens, must file a claim within 60 days after the sale.

If you are a person with a disability who needs any accommodation in order to participate in this proceeding, you are entitled, at no cost to you, to the provision of certain assistance. Please contact the Sarasota County Jury Office, P.O. Box 3079, Sarasota, Florida 34230-3079, (941)861-7400, at least seven (7) days before your scheduled court appearance, or immediately upon receiving this notification if the time before the scheduled appearance is less than seven (7) days; if you are hearing or voice impaired, call 711.

ATTORNEY FOR PLAINTIFF

By /S/ Josh D. Donnelly
Josh D. Donnelly
Florida Bar #64788

Date: 05/23/2014

THIS INSTRUMENT PREPARED BY:
Law Offices Of Daniel C. Consuegra
9204 King Palm Drive
Tampa, FL 33619-1328
Phone: 813-915-8660
Attorneys for Plaintiff
62456-T

May 30; June 6, 2014 14-02427S

FIRST INSERTION

NOTICE OF SALE
IN THE CIRCUIT COURT OF THE
TWELFTH JUDICIAL CIRCUIT OF
THE STATE OF FLORIDA, IN AND
FOR SARASOTA COUNTY
CIVIL DIVISION
CASE NO.

58-2013-CA-001453-XXXX-NC
JPMORGAN CHASE BANK,
NATIONAL ASSOCIATION,
Plaintiff, vs.

SHAWN KRSTONICH;
UNKNOWN SPOUSE OF
SHAWN KRSTONICH;
PATRICIA KRSTONICH;
UNKNOWN SPOUSE OF
PATRICIA KRSTONICH; IF
LIVING, INCLUDING ANY
UNKNOWN SPOUSE OF SAID
DEFENDANT(S), IF REMARRIED,
AND IF DECEASED, THE
RESPECTIVE UNKNOWN
HEIRS, DEVISEES, GRANTEEES,
ASSIGNEES, CREDITORS,
LIENORS, AND TRUSTEES,
AND ALL OTHER PERSONS
CLAIMING BY, THROUGH,
UNDER OR AGAINST THE
NAMED DEFENDANT(S);
SUNTRUST BANK; WHETHER
DISSOLVED OR PRESENTLY
EXISTING, TOGETHER WITH
ANY GRANTEEES, ASSIGNEES,
CREDITORS, LIENORS,
OR TRUSTEES OF SAID
DEFENDANT(S) AND ALL
OTHER PERSONS CLAIMING
BY, THROUGH, UNDER, OR
AGAINST DEFENDANT(S);
UNKNOWN TENANT #1;
UNKNOWN TENANT #2;
Defendant(s)

Notice is hereby given that, pursuant to a Final Summary Judgment of Foreclosure entered on 05/12/2014 in the above styled cause, in the Circuit Court of Sarasota County, Florida, the office of Karen E. Rushing clerk of the circuit

court will sell the property situate in Sarasota County, Florida, described as:
LOT 14, BLOCK 1119, 25TH ADDITION TO PORT CHARLOTTE SUBDIVISION, ACCORDING TO THE PLAT THEREOF, RECORDED IN PLAT BOOK 15, PAGE 2, OF THE PUBLIC RECORDS OF SARASOTA COUNTY, FLORIDA.

at public sale, to the highest and best bidder, for cash, www.sarasota.real-foreclose.com at 9:00 o'clock, A.M., on June 17, 2014

Any person claiming an interest in the surplus from the sale, if any, other than the property owner as of the date of the lis pendens, must file a claim within 60 days after the sale.

If you are a person with a disability who needs any accommodation in order to participate in this proceeding, you are entitled, at no cost to you, to the provision of certain assistance. Please contact the Sarasota County Jury Office, P.O. Box 3079, Sarasota, Florida 34230-3079, (941)861-7400, at least seven (7) days before your scheduled court appearance, or immediately upon receiving this notification if the time before the scheduled appearance is less than seven (7) days; if you are hearing or voice impaired, call 711.

ATTORNEY FOR PLAINTIFF

By /S/ Josh D. Donnelly
Josh D. Donnelly
Florida Bar #64788

Date: 05/23/2014

THIS INSTRUMENT PREPARED BY:
Law Offices Of Daniel C. Consuegra
9204 King Palm Drive
Tampa, FL 33619-1328
Phone: 813-915-8660
Attorneys for Plaintiff
133957

May 30; June 6, 2014 14-02420S

FIRST INSERTION

NOTICE OF SALE
IN THE CIRCUIT COURT OF THE
TWELFTH JUDICIAL CIRCUIT OF
THE STATE OF FLORIDA, IN AND
FOR SARASOTA COUNTY
CIVIL DIVISION
CASE NO.

58-2010-CA-001065-XXXX-NC
U.S. BANK NATIONAL
ASSOCIATION AS TRUSTEE FOR
THE CERTIFICATEHOLDERS OF
CITIGROUP MORTGAGE LOAN
TRUST INC. ASSET-BACKED
PASS-THROUGH CERTIFICATES
SERIES 2007-AMCI,
Plaintiff, vs.

JENNIFER BARNES; THE
UNKNOWN SPOUSE OF
JENNIFER BARNES; ROBERT
BARNES; THE UNKNOWN
SPOUSE OF ROBERT BARNES;
IF LIVING, INCLUDING ANY
UNKNOWN SPOUSE OF SAID
DEFENDANT(S), IF REMARRIED,
AND IF DECEASED, THE
RESPECTIVE UNKNOWN
HEIRS, DEVISEES, GRANTEEES,
ASSIGNEES, CREDITORS,
LIENORS, AND TRUSTEES,
AND ALL OTHER PERSONS
CLAIMING BY, THROUGH,
UNDER OR AGAINST THE
NAMED DEFENDANT(S);
UNITED STATES OF AMERICA;

WHETHER DISSOLVED
OR PRESENTLY EXISTING,
TOGETHER WITH ANY
GRANTEEES, ASSIGNEES,
CREDITORS, LIENORS,
OR TRUSTEES OF SAID
DEFENDANT(S) AND ALL
OTHER PERSONS CLAIMING
BY, THROUGH, UNDER, OR
AGAINST DEFENDANT(S);
UNKNOWN TENANT #1;
UNKNOWN TENANT #2;
Defendant(s)

Notice is hereby given that, pursuant to a Final Summary Judgment of Foreclosure entered on 01/22/2014 in the above styled cause, in the Circuit Court of Sarasota County, Florida, the office of Karen E. Rushing clerk of the circuit court will sell the property situate in Sarasota County, Florida, described as:

LOT 17 BLOCK 56 OF FOURTH ADDITION TO PORT CHARLOTTE SUBDIVISION ACCORDING TO THE PLAT THEREOF AS RECORDED IN PLAT BOOK 11 PAGE 32 OF THE PUBLIC RECORDS OF SARASOTA COUNTY, FLORIDA.

at public sale, to the highest and best bidder, for cash, www.sarasota.real-foreclose.com at 9:00 o'clock, A.M., on

FIRST INSERTION

NOTICE OF SALE
IN THE CIRCUIT COURT OF THE
TWELFTH JUDICIAL CIRCUIT OF
THE STATE OF FLORIDA, IN AND
FOR SARASOTA COUNTY
CIVIL DIVISION
CASE NO.

58-2010-CA-000714-XXXX-NC
THE BANK OF NEW YORK
MELLON AS SUCCESSOR BY
MERGER TO THE BANK OF
NEW YORK, AS TRUSTEE FOR
THE CERTIFICATEHOLDERS,
CWABS, INC., ASSET-BACKED
CERTIFICATES, SERIES
2006-BC5,
Plaintiff, vs.

DANNETTE R. GRIFFITH;
UNKNOWN SPOUSE OF
DANNETTE R. GRIFFITH; IF
LIVING, INCLUDING ANY
UNKNOWN SPOUSE OF SAID
DEFENDANT(S), IF REMARRIED,
AND IF DECEASED, THE
RESPECTIVE UNKNOWN
HEIRS, DEVISEES, GRANTEEES,
ASSIGNEES, CREDITORS,
LIENORS, AND TRUSTEES,
AND ALL OTHER PERSONS
CLAIMING BY, THROUGH,
UNDER OR AGAINST THE
NAMED DEFENDANT(S); BENT
TREE VILLAGE ASSOCIATION,
INC; WHETHER DISSOLVED
OR PRESENTLY EXISTING,
TOGETHER WITH ANY
GRANTEEES, ASSIGNEES,
CREDITORS, LIENORS,
OR TRUSTEES OF SAID
DEFENDANT(S) AND ALL
OTHER PERSONS CLAIMING
BY, THROUGH, UNDER, OR
AGAINST DEFENDANT(S);
UNKNOWN TENANT #1;
UNKNOWN TENANT #2;
Defendant(s)

Notice is hereby given that, pursuant to a Final Summary Judgment of Foreclosure entered on 02/19/2014 in the above styled cause, in the Circuit Court of Sarasota County, Florida, the

office of Karen E. Rushing clerk of the circuit court will sell the property situate in Sarasota County, Florida, described as:

LOT 29, BENT TREE VILLAGE SUBDIVISION, ACCORDING TO THE MAP OR PLAT THEREOF AS RECORDED IN PLAT BOOK 23, PAGES 12, 12A THROUGH 12G, INCLUSIVE, OF THE PUBLIC RECORDS OF SARASOTA COUNTY, FLORIDA.

at public sale, to the highest and best bidder, for cash, www.sarasota.real-foreclose.com at 9:00 o'clock, A.M., on June 19, 2014

Any person claiming an interest in the surplus from the sale, if any, other than the property owner as of the date of the lis pendens, must file a claim within 60 days after the sale.

If you are a person with a disability who needs any accommodation in order to participate in this proceeding, you are entitled, at no cost to you, to the provision of certain assistance. Please contact the Sarasota County Jury Office, P.O. Box 3079, Sarasota, Florida 34230-3079, (941)861-7400, at least seven (7) days before your scheduled court appearance, or immediately upon receiving this notification if the time before the scheduled appearance is less than seven (7) days; if you are hearing or voice impaired, call 711.

ATTORNEY FOR PLAINTIFF

By /S/ Josh D. Donnelly
Josh D. Donnelly
Florida Bar #64788

Date: 05/23/2014

THIS INSTRUMENT PREPARED BY:
Law Offices Of Daniel C. Consuegra
9204 King Palm Drive
Tampa, FL 33619-1328
Phone: 813-915-8660
Attorneys for Plaintiff
55755-T

May 30; June 6, 2014 14-02425S

FIRST INSERTION

NOTICE OF SALE
IN THE CIRCUIT COURT OF THE
TWELFTH JUDICIAL CIRCUIT OF
THE STATE OF FLORIDA, IN AND
FOR SARASOTA COUNTY
CIVIL DIVISION
CASE NO.

58-2011-CA-003496-XXXX-NC
GTE FEDERAL CREDIT UNION,
Plaintiff, vs.

JULIAN A. MORGAN III;
UNKNOWN SPOUSE OF
JULIAN A. MORGAN III; IF
LIVING, INCLUDING ANY
UNKNOWN SPOUSE OF SAID
DEFENDANT(S), IF REMARRIED,
AND IF DECEASED, THE
RESPECTIVE UNKNOWN
HEIRS, DEVISEES, GRANTEEES,
ASSIGNEES, CREDITORS,
LIENORS, AND TRUSTEES,
AND ALL OTHER PERSONS
CLAIMING BY, THROUGH,
UNDER OR AGAINST THE
NAMED DEFENDANT(S);
COMPANION PROPERTY
AND CASUALTY INSURANCE
COMPANY; THE INDEPENDENT
SAVINGS PLAN COMPANY
D/B/A ISPC; UNITED STATES
OF AMERICA; WHETHER
DISSOLVED OR PRESENTLY
EXISTING, TOGETHER WITH
ANY GRANTEEES, ASSIGNEES,
CREDITORS, LIENORS,
OR TRUSTEES OF SAID
DEFENDANT(S) AND ALL
OTHER PERSONS CLAIMING
BY, THROUGH, WHETHER UNDER,
OR AGAINST DEFENDANT(S);
UNKNOWN TENANT #1;
UNKNOWN TENANT #2;
Defendant(s)

Notice is hereby given that, pursuant to a Final Summary Judgment of Foreclosure entered on 08/26/2013 in the above styled cause, in the Circuit Court of Sarasota County, Florida, the office

of Karen E. Rushing clerk of the circuit court will sell the property situate in Sarasota County, Florida, described as:
LOTS 591 AND 592, DESOTO LAKES UNIT NO. 10, ACCORDING TO THE PLAT THEREOF, AS RECORDED IN PLAT BOOK 9, PAGE 15, OF THE PUBLIC RECORDS OF SARASOTA COUNTY, FLORIDA.

at public sale, to the highest and best bidder, for cash, www.sarasota.real-foreclose.com at 9:00 o'clock, A.M., on June 19, 2014

Any person claiming an interest in the surplus from the sale, if any, other than the property owner as of the date of the lis pendens, must file a claim within 60 days after the sale.

If you are a person with a disability who needs any accommodation in order to participate in this proceeding, you are entitled, at no cost to you, to the provision of certain assistance. Please contact the Sarasota County Jury Office, P.O. Box 3079, Sarasota, Florida 34230-3079, (941)861-7400, at least seven (7) days before your scheduled court appearance, or immediately upon receiving this notification if the time before the scheduled appearance is less than seven (7) days; if you are hearing or voice impaired, call 711.

ATTORNEY FOR PLAINTIFF

By /S/ Josh D. Donnelly
Josh D. Donnelly
Florida Bar #64788

Date: 05/23/2014

THIS INSTRUMENT PREPARED BY:
Law Offices Of Daniel C. Consuegra
9204 King Palm Drive
Tampa, FL 33619-1328
Phone: 813-915-8660
Attorneys for Plaintiff
89990

May 30; June 6, 2014 14-02419S

FIRST INSERTION

NOTICE OF FORECLOSURE SALE
IN THE CIRCUIT COURT OF THE
TWELFTH JUDICIAL CIRCUIT
IN AND FOR SARASOTA COUNTY,
FLORIDA
CIVIL ACTION
CASE NO.: 2009-CA-017486-NC
DIVISION: C

HSBC BANK USA,
Plaintiff, vs.
RONALD C. SHOENBERGER,
et al,
Defendant(s).

NOTICE IS HEREBY GIVEN pursuant to a Final Judgment of Mortgage Foreclosure dated May 22, 2014 and entered in Case No. 2009-CA-017486-NC of the Circuit Court of the TWELFTH Judicial Circuit in and for SARASOTA County, Florida wherein HSBC BANK USA, N.A., Plaintiff name has changed pursuant to order previously entered, is the Plaintiff and RONALD C. SHOENBERGER; LINDA SHOENBERGER; JPMORGAN CHASE BANK, N.A.; are the Defendants. The Clerk will sell to the highest and best bidder for cash at WWW.SARASOTA.REALFORECLOSE.COM at 9:00AM, on the 26th day of June, 2014, the following described property as set forth in said Final Judgment:

THE EAST 1/2 OF THE WEST 1/2 OF THE SOUTHEAST 1/4 OF THE SOUTHEAST 1/4 OF SECTION 26, TOWNSHIP 36 SOUTH, RANGE 29 EAST, SARASOTA COUNTY, FLORIDA. TOGETHER WITH A NON EXCLUSIVE PERPETUAL EASEMENT FOR INGRESS AND EGRESS OVER THE FOLLOWING DESCRIBED PARCEL OF LAND. THE SOUTHERLY MOST 25 FEET OF THE SOUTHEAST

1/4 OF THE SOUTHEAST 1/4 OF SECTION 26 SOUTH, RANGE 20 EAST, AND THE SOUTHERLY MOST 25 FEET OF THE SOUTHWEST 1/4 OF SECTION 25, TOWNSHIP 36 SOUTH, RANGE 20 EAST, SARASOTA COUNTY, FLORIDA, LESS THAT PORTION THEREOF FOR THE RIGHT OF WAY OF STATE ROAD 780 (OLD MYAKKA ROAD)

A/K/A 15765 RAWLS ROAD, SARASOTA, FL 34240

Any person claiming an interest in the surplus from the sale, if any, other than the property owner as of the date of the Lis Pendens must file a claim within sixty (60) days after the sale.

If you are a person with a disability who needs any accommodation in order to participate in this proceeding, you are entitled, at no cost to you, to the provision of certain assistance. Please contact the Sarasota County Jury Office, P.O. Box 3079, Sarasota, Florida 34230-3079, (941)861-7400, at least seven (7) days before your scheduled court appearance, or immediately upon receiving this notification if the time before the scheduled appearance is less than seven (7) days; if you are hearing or voice impaired, call 711.

By: Lisa M. Lewis

Florida Bar No. 0086178

Ronald R Wolfe & Associates, P.L.L.C.

P.O. Box 25018

Tampa, Florida 33622-5018

(813) 251-4766

(813) 251-1541 Fax

F09103515

May 30; June 6, 2014 14-02407S

FIRST INSERTION

NOTICE OF SALE
IN THE CIRCUIT COURT OF THE
TWELFTH JUDICIAL CIRCUIT OF
THE STATE OF FLORIDA, IN AND
FOR SARASOTA COUNTY
CIVIL DIVISION
CASE NO. 2013 CA 002749 NC

PNC BANK, NATIONAL
ASSOCIATION, SUCCESSOR IN
INTEREST TO NATIONAL CITY
REAL ESTATE SERVICES, LLC,
SUCCESSOR BY MERGER TO
NATIONAL CITY MORTGAGE,
INC., FORMERLY KNOWN AS
NATIONAL CITY MORTGAGE CO.,
A SUBSIDIARY OF NATIONAL
CITY BANK OF INDIANA,
Plaintiff, vs.

UNKNOWN HEIRS, DEVISEES,
GRANTEEES, ASSIGNEES,
CREDITORS, LIENORS,
TRUSTEES OF ALBERT
A. HASHEM, DECEASED;
STEPHEN HASHEM, HEIR;
CHARLES HASHEM, HEIR;
KATHY ANN RICHARDS, HEIR;
SHARON HASHEM, HEIR;
IF LIVING, INCLUDING ANY
UNKNOWN SPOUSE OF SAID
DEFENDANT(S), IF REMARRIED,
AND IF DECEASED, THE
RESPECTIVE UNKNOWN
HEIRS, DEVISEES, GRANTEEES,
ASSIGNEES, CREDITORS,
LIENORS, AND TRUSTEES,
AND ALL OTHER PERSONS
CLAIMING BY, THROUGH,
UNDER OR AGAINST THE
NAMED DEFENDANT(S);
UNKNOWN TENANT # 1;
UNKNOWN TENANT #2;
Defendant(s)

Notice is hereby given that, pursuant to a Final Summary Judgment of Foreclosure entered on 05/12/2014 in the above styled cause, in the Circuit Court of Sarasota County, Florida, the office of Karen E. Rushing clerk of the circuit court will sell the property situate in Sarasota County, Florida,

described as:
LOT 22, BLK 1401, 28TH ADDITION TO PORT CHARLOTTE SUBDIVISION ACCORDING TO THE PLAT THEREOF, RECORDED IN PLAT BOOK 15, PAGE(S) 12, OF THE PUBLIC RECORDS OF SARASOTA COUNTY, FLORIDA.

Property Commonly Known As:
5905 Humkey North Port, FL 34286

at public sale, to the highest and best bidder, for cash, www.sarasota.real-foreclose.com at 9:00 o'clock, A.M., on June 17, 2014

Any person claiming an interest in the surplus from the sale, if any, other than the property owner as of the date of the lis pendens, must file a claim within 60 days after the sale.

If you are a person with a disability who needs any accommodation in order to participate in this proceeding, you are entitled, at no cost to you, to the provision of certain assistance. Please contact the Sarasota County Jury Office, P.O. Box 3079, Sarasota, Florida 34230-3079, (941)861-7400, at least seven (7) days before your scheduled court appearance, or immediately upon receiving this notification if the time before the scheduled appearance is less than seven (7) days; if you are hearing or voice impaired, call 711.

ATTORNEY FOR PLAINTIFF

By /S/ Josh D. Donnelly
Josh D. Donnelly
Florida Bar #64788

Date: 05/23/2014

THIS INSTRUMENT PREPARED BY:
Law Offices Of Daniel C. Consuegra
9204 King Palm Drive
Tampa, FL 33619-1328
Phone: 813-915-8660
Attorneys for Plaintiff
143385

May 30; June 6, 2014 14-02422S

FIRST INSERTION

NOTICE OF SALE
IN THE CIRCUIT COURT OF THE
TWELFTH JUDICIAL CIRCUIT OF
THE STATE OF FLORIDA, IN AND
FOR SARASOTA COUNTY
CIVIL DIVISION
CASE NO.

58-2013-CA-001429-XXXX-NC
CALIBER HOME LOANS, INC.,
Plaintiff, vs.

PETER M HANSON; UNKNOWN
SPOUSE OF PETER M HANSON;
SUE C CLAYTON; UNKNOWN
SPOUSE SUE C CLAYTON;
IF LIVING, INCLUDING
ANY UNKNOWN SPOUSE
OF SAID DEFENDANT(S),
IF REMARRIED, AND IF
DECEASED, THE RESPECTIVE
UNKNOWN HEIRS, DEVISEES,
GRANTEEES, ASSIGNEES,
CREDITORS, LIENORS,
AND TRUSTEES, AND ALL
OTHER PERSONS CLAIMING
BY, THROUGH, UNDER
OR AGAINST THE NAMED
DEFENDANT(S); SUNRISE COVE
CONDOMINIUM ASSOCIATION,
INC.; CROWTHER ROOFING
AND SHEET METAL OF
FLORIDA, INC.; WHETHER
DISSOLVED OR PRESENTLY
EXISTING, TOGETHER WITH
ANY GRANTEEES, ASSIGNEES,

CREDITORS, LIENORS,
OR TRUSTEES OF SAID
DEFENDANT(S) AND ALL
OTHER PERSONS CLAIMING
BY, THROUGH, UNDER, OR
AGAINST DEFENDANT(S);
UNKNOWN TENANT #1;
UNKNOWN TENANT #2;
Defendant(s)

Notice is hereby given that, pursuant to a Final Summary Judgment of Foreclosure entered on 02/24/2014 in the above-styled cause, in the Circuit Court of Sarasota County, Florida, the office of Karen E. Rushing clerk of the circuit court will sell the property situate in Sarasota County, Florida, described as:

CONDOMINIUM UNIT NO. 121, SUNRISE COVE CONDOMINIUM, SECTION THREE, ACCORDING TO THE DECLARATION THEREOF, AS RECORDED IN OFFICIAL RECORDS BOOK 1041, PAGES 1 THROUGH 62 AND CONDOMINIUM PLAT BOOK 7, PAGES 35 AND 35A, BOTH OF THE PUBLIC RECORDS OF SARASOTA COUNTY, FLORIDA.

at public sale, to the highest and best bidder, for cash, www.sarasota.real-foreclose.com at 9:00 o'clock, A.M., on June 17, 2014

Any person claiming an interest in the surplus from the sale, if any, other than the property owner as of the date of the lis pendens, must file a claim within 60 days after the sale.

If you are a person with a disability who needs any accommodation in order to participate in this proceeding, you are entitled, at no cost to you, to the provision of certain assistance. Please contact the Sarasota County Jury Office, P.O. Box 3079, Sarasota, Florida 34230-3079, (941)861-7400, at least seven (7) days before your scheduled court appearance, or immediately upon receiving this notification if the time before the scheduled appearance is less than seven (7) days; if you are hearing or voice impaired, call 711.

ATTORNEY FOR PLAINTIFF

By /S/ Josh D. Donnelly
Josh D. Donnelly
Florida Bar #64788

Date: 05/23/2014

THIS INSTRUMENT PREPARED BY:
Law Offices Of Daniel C. Consuegra
9204 King Palm Drive
Tampa, FL 33619-1328
Phone: 813-915-8660
Attorneys for Plaintiff
145936-T

May 30; June 6, 2014 14-02416S

FIRST INSERTION

NOTICE OF FORECLOSURE SALE PURSUANT TO CHAPTER 45 IN THE CIRCUIT COURT OF THE TWELFTH JUDICIAL CIRCUIT IN AND FOR SARASOTA COUNTY, FLORIDA

CASE NO. 2011 CA 005955 NC
U.S. BANK NATIONAL ASSOCIATION AS TRUSTEE RASC 2005KS2, Plaintiff(s), vs. ROBERT KACPRZAK; et al., Defendant(s).

NOTICE IS HEREBY GIVEN that Sale will be made pursuant to an Order or Final Summary Judgment. Final Judgment was awarded on February 13, 2014 in Civil Case No.: 2011 CA 005955 NC, of the Circuit Court of the TWELFTH Judicial Circuit in and for SARASOTA County, Florida, wherein, U.S. BANK NATIONAL ASSOCIATION AS TRUSTEE RASC 2005KS2, is the Plaintiff, and, ROBERT KACPRZAK; AND UNKNOWN TENANT(S) IN POSSESSION are Defendants.

The clerk of the court, Karen E. Rushing, will sell to the highest bidder for cash online at www.sarasota.realforeclose.com at 9:00 AM on June 13, 2014, the following described real property as set forth in said Final summary Judgment, to-wit:

LOT 79, LAUREL WOODLANDS, AS PER PLAT THEREOF RECORDED IN PLAT BOOK 31, PAGES 42, 42A TO 42E, INCLUSIVE, OF THE PUBLIC RECORDS OF SARASOTA COUNTY, FLORIDA.

ANY PERSON CLAIMING AN INTEREST IN THE SURPLUS FROM THE SALE, IF ANY, OTHER THAN THE PROPERTY OWNER AS OF THE DATE OF THE LIS PENDENS MUST FILE A CLAIM WITHIN 60 DAYS AFTER THE SALE.

If you are a person with a disability who needs any accommodation in order to participate in this proceeding, you are entitled, at no cost to you, to the provision of certain assistance. Please contact the Sarasota County Jury Office, P.O. Box 3079, Sarasota, Florida 34230-3079, (941)861-7400, at least seven (7) days before your scheduled court appearance, or immediately upon receiving this notification if the time before the scheduled appearance is less than seven (7) days; if you are hearing or voice impaired, call 711.

Dated this 27 day of MAY, 2014.

BY: Nalini Singh
Fla. Bar #43700

Aldridge Connors, LLP
Attorney for Plaintiff(s)
1615 South Congress Avenue,
Suite 200
Delray Beach, FL 33445
Phone: 561.392.6391
Fax: 561.392.6965
Primary E-Mail:
ServiceMail@aqlawllp.com
1221-8460B
May 30; June 6, 2014 14-02462S

FIRST INSERTION

NOTICE OF SALE IN THE COUNTY COURT IN AND FOR SARASOTA COUNTY, FLORIDA

CASE NUMBER:
2014 CC 000763 SC
VILLAS OF VENICE INC. CONDOMINIUM ASSOCIATION, a Florida not-for-profit corporation, PLAINTIFF VS RAYMOND MIRARCHI; PAMELA DI TULLIO MIRARCHI; TENANT #1; and TENANT #2, as unknown tenant(s) in Possession, DEFENDANT

Notice is hereby given pursuant to the final judgment/order entered in the above noted case, that I will sell the following property situated in Sarasota County, Florida, described as:

Unit 72, VENICE VILLAS, a Condominium according to the Declaration of Condominium recorded in Official Records Book 1074, Pages 1127 through 1162, inclusive, and all amendments thereto, and as per plat thereof recorded in Condominium Book 8, Pages 36, 36A through 36F, inclusive, of the Public Records of Sarasota County, Florida, together with an undivided interest in the common elements.

at public sale, to the highest and best bidder for cash, via the Internet: www.sarasota.realforeclose.com at

FIRST INSERTION

NOTICE OF FORECLOSURE SALE IN THE CIRCUIT COURT OF THE TWELFTH JUDICIAL CIRCUIT OF FLORIDA IN AND FOR SARASOTA COUNTY GENERAL JURISDICTION DIVISION

CASE NO. 2009 CA 012177 NC
OCWEN LOAN SERVICING, LLC, Plaintiff, vs. TIMOTHY MURPHY, et al., Defendants.

NOTICE IS HEREBY GIVEN pursuant to a Summary Final Judgment of Foreclosure entered May 19, 2014 in Civil Case No. 2009 CA 012177 NC of the Circuit Court of the TWELFTH Judicial Circuit in and for Sarasota County, Florida, wherein OCWEN LOAN SERVICING, LLC is Plaintiff and TIMOTHY MURPHY, UNKNOWN TENANT #1, UNKNOWN SPOUSE OF TIMOTHY MURPHY, are Defendants, the Clerk of Court will sell to the highest and best bidder for cash electronically at www.sarasota.realforeclose.com in accordance with Chapter 45, Florida Statutes on the 24th day of June, 2014 at 09:00 AM on the following described property as set forth in said Summary Final Judgment, to-wit:

Lot 114, LESS right-of-way for Tuttle Avenue, as described in Official Records Book 2653 Page 1127, PAVER PARK ESTATES, SECOND ADDITION, according to the plat thereof recorded in Plat Book 7 Page 95, Public Records of Sarasota County, Florida.

Any person claiming an interest in the surplus from the sale, if any, other than the property owner as of the date of the lis pendens, must file a claim within 60 days after the sale.

If you are a person with a disability who needs any accommodation in order to participate in this proceeding, you are entitled, at no cost to you, to the provision of certain assistance. Please contact the Sarasota County Jury Office, P.O. Box 3079, Sarasota, Florida 34230-3079, (941)861-7400, at least seven (7) days before your scheduled court appearance, or immediately upon receiving this notification if the time before the scheduled appearance is less than seven (7) days; if you are hearing or voice impaired, call 711.

ROBYN KATZ
FLORIDA BAR NO.: 0146803
Brian Hummel, Esq.
Fla. Bar No.: 46162

McCalla Raymer, LLC
Attorney for Plaintiff
225 E. Robinson St. Suite 660
Orlando, FL 32801
Phone: (407) 674-1850
Fax: (321) 248-0420
Email:
MRSservice@mccallarayer.com
2880461
11-02881-5
May 30; June 6, 2014 14-02460S

09:00 a.m. on June 16, 2014. Final payment must be made on or before 4:00 p.m. of the date of the sale by cash or cashier's check, or initiated ACH or Wire Transfer.

ANY PERSON CLAIMING AN INTEREST IN THE SURPLUS FROM THE SALE, IF ANY, OTHER THAN THE PROPERTY OWNER AS OF THE DATE OF THE LIS PENDENS MUST FILE A CLAIM WITHIN 60 DAYS AFTER THE SALE.

If you are a person with a disability who needs any accommodation in order to participate in this proceeding, you are entitled, at no cost to you, to the provision of certain assistance. Please contact the Sarasota County Jury Office, P.O. Box 3079, Sarasota, Florida 34230-3079, (941)861-7400, at least seven (7) days before your scheduled court appearance, or immediately upon receiving this notification if the time before the scheduled appearance is less than seven (7) days; if you are hearing or voice impaired, call 711.

KAREN E. RUSHING
CLERK OF THE CIRCUIT COURT
(SEAL) BY: J HERNANDEZ
Deputy Clerk

The Law Offices of
Lobeck & Hanson, P.A.
2033 Main Street, Suite 403
Sarasota, Florida 34237-6063
(941) 955-5622 / Fax: (941) 951-1469
May 30; June 6, 2014 14-02465S

FIRST INSERTION

NOTICE OF SALE IN THE CIRCUIT COURT OF THE TWELFTH JUDICIAL CIRCUIT OF THE STATE OF FLORIDA, IN AND FOR SARASOTA COUNTY CIVIL DIVISION

CASE NO. 58-2011-CA-004314-XXXX-NC
JPMORGAN MORTGAGE ACQUISITION CORP., Plaintiff, vs. ELISSA A. SIMERLY; VINTAGE GRAND CONDOMINIUM ASSOCIATION, INC.; PALMER RANCH MASTER PROPERTY OWNERS ASSOCIATION, INC.; WHETHER DISSOLVED OR PRESENTLY EXISTING, TOGETHER WITH ANY GRANTEEES, ASSIGNEES, CREDITORS, LIENORS, OR TRUSTEES OF SAID DEFENDANT(S) AND ALL OTHER PERSONS CLAIMING BY, THROUGH, UNDER, OR AGAINST DEFENDANT(S); UNKNOWN TENANT #2; Defendant(s)

Notice is hereby given that, pursuant to a Final Summary Judgment of Foreclosure entered on 05/12/2014 in the above styled cause, in the Circuit Court of Sarasota County, Florida, the office of Karen E. Rushing clerk of the circuit court will sell the property situate in Sarasota County, Florida, described as:

CONDOMINIUM UNIT NO. 21, BUILDING 11, VINTAGE GRAND CONDOMINIUM, ACCORDING TO THE DECLARATION THEREOF, AS

RECORDED IN OFFICIAL RECORDS INSTRUMENT NO. 2005281688, OF THE PUBLIC RECORDS OF SARASOTA COUNTY, FLORIDA.

at public sale, to the highest and best bidder, for cash, www.sarasota.realforeclose.com at 9:00 o'clock, A.M., on June 17, 2014

Any person claiming an interest in the surplus from the sale, if any, other than the property owner as of the date of the lis pendens, must file a claim within 60 days after the sale.

If you are a person with a disability who needs any accommodation in order to participate in this proceeding, you are entitled, at no cost to you, to the provision of certain assistance. Please contact the Sarasota County Jury Office, P.O. Box 3079, Sarasota, Florida 34230-3079, (941)861-7400, at least seven (7) days before your scheduled court appearance, or immediately upon receiving this notification if the time before the scheduled appearance is less than seven (7) days; if you are hearing or voice impaired, call 711.

ATTORNEY FOR PLAINTIFF
By /S/ Josh D. Donnelly
Josh D. Donnelly
Florida Bar #64788

Date: 05/23/2014
THIS INSTRUMENT PREPARED BY:
Law Offices Of Daniel C. Consuegra
9204 King Palm Drive
Tampa, FL 33619-1328
Phone: 813-915-8660
Attorneys for Plaintiff
86609-T
May 30; June 6, 2014 14-02421S

FIRST INSERTION

NOTICE OF FORECLOSURE SALE IN THE CIRCUIT COURT OF THE TWELFTH JUDICIAL CIRCUIT OF FLORIDA IN AND FOR SARASOTA COUNTY GENERAL JURISDICTION DIVISION

CASE NO. 58-2012-CA-005326 NC
THE BANK OF NEW YORK MELLON FKA THE BANK OF NEW YORK, AS TRUSTEE FOR THE CERTIFICATEHOLDERS OF CWABS, INC., ASSET-BACKED CERTIFICATES, SERIES 2006-8, Plaintiff, vs. DANIEL A. SILVA, et al., Defendants.

NOTICE IS HEREBY GIVEN pursuant to a Summary Final Judgment of Foreclosure entered May 20, 2014 in Civil Case No. 58-2012-CA-005326 NC of the Circuit Court of the TWELFTH Judicial Circuit in and for Sarasota County, Florida, wherein THE BANK OF NEW YORK MELLON FKA THE BANK OF NEW YORK, AS TRUSTEE FOR THE CERTIFICATEHOLDERS OF CWABS, INC., ASSET-BACKED CERTIFICATES, SERIES 2006-8 is Plaintiff and SARAH O. BEAMISH, DANIEL A. SILVA, UNKNOWN TENANT(S) N/K/A ROBERT BEAMISH, UNKNOWN TENANT(S) N/K/A SARAH BEAMISH, UNKNOWN SPOUSE OF DANIEL A. SILVA, UNKNOWN SPOUSE OF SARAH O. BEAMISH, are Defendants, the Clerk of Court will sell to the highest and best bidder for cash electronically at www.sarasota.realforeclose.com in accordance with Chapter 45, Florida Statutes on the 25th day of June, 2014 at 09:00 AM on the following described property as set forth in said Summary Final Judgment, to-wit:

Lot 13, Block 994, 21ST, ADDITION TO PORT CHARLOTTE SUBDIVISION, according to the plat thereof, as recorded in Plat Book 14, at Pages 9, 9A through 9I, in the Public Records of Sarasota County, Florida. Tax ID: 1136099413

Any person claiming an interest in the surplus from the sale, if any, other than the property owner as of the date of the lis pendens, must file a claim within 60 days after the sale.

If you are a person with a disability who needs any accommodation in order to participate in this proceeding, you are entitled, at no cost to you, to the provision of certain assistance. Please contact the Sarasota County Jury Office, P.O. Box 3079, Sarasota, Florida 34230-3079, (941)861-7400, at least seven (7) days before your scheduled court appearance, or immediately upon receiving this notification if the time before the scheduled appearance is less than seven (7) days; if you are hearing or voice impaired, call 711.

ROBYN KATZ
FLORIDA BAR NO.: 0146803
Brian Hummel, Esq.
Fla. Bar No.: 46162

McCalla Raymer, LLC
Attorney for Plaintiff
225 E. Robinson St.
Suite 660
Orlando, FL 32801
Phone: (407) 674-1850
Fax: (321) 248-0420
Email:
MRSservice@mccallarayer.com
2880579
13-00789-5
May 30; June 6, 2014 14-02461S

FIRST INSERTION

NOTICE OF SALE IN THE CIRCUIT COURT OF THE TWELFTH JUDICIAL CIRCUIT IN AND FOR SARASOTA COUNTY, FLORIDA

Case No.: 58-2013-CA-003093 NC
Section: C
CITIMORTGAGE, INC. Plaintiff, v.

UNKNOWN HEIRS, DEVISEES, GRANTEEES, LIENORS AND OTHER PARTIES TAKING INTEREST UNDER THE ESTATE OF JANICE R. LINDSTROM; LAWRENCE T. CONNELLY; TRISTAN D. LINDSTROM; TIMOTHY B. LINDSTROM; ANY AND ALL UNKNOWN PARTIES CLAIMING BY, THROUGH, UNDER, AND AGAINST THE HEREIN NAMED INDIVIDUAL DEFENDANT(S) WHO ARE NOT KNOWN TO BE DEAD OR ALIVE, WHETHER SAID UNKNOWN PARTIES MAY CLAIM AN INTEREST AS SPOUSES, HEIRS, DEVISEES, GRANTEEES, OR OTHER CLAIMANTS; WELLS FARGO BANK, NATIONAL ASSOCIATION, SUCCESSOR BY MERGER TO WACHOVIA BANK, NATIONAL ASSOCIATION, SUCCESSOR BY MERGER TO SOUTHTRUST BANK. Defendant(s).

NOTICE IS HEREBY GIVEN pursuant to an Order of Amended Uniform Final Judgment of Mortgage Foreclosure dated May 12, 2014, entered in Civil Case No. 58-2013-CA-003093 NC of the Circuit Court of the Twelfth Judicial Circuit in and for Sarasota County, Florida, wherein the Clerk of the Circuit Court will sell to the highest bidder for cash on

the 18th day of June, 2014, at 9:00 a.m. online at the website: <https://www.sarasota.realforeclose.com>, relative to the following described property as set forth in the Final Judgment, to-wit:

LOT 1426 SARASOTA SPRINGS, UNIT 12, ACCORDING TO THE PLAT THEREOF, RECORDED IN PLAT BOOK 8, PAGE 42, OF THE PUBLIC RECORDS OF SARASOTA COUNTY, FLORIDA.

Any person claiming an interest in the surplus from the sale, if any, other than the property owner as of the date of the Lis Pendens must file a claim within 60 days after the sale.

If you are a person with a disability who needs any accommodation in order to participate in this proceeding, you are entitled, at no cost to you, to the provision of certain assistance. Please contact the Sarasota County Jury Office, P.O. Box 3079, Sarasota, Florida 34230-3079, (941)861-7400, at least seven (7) days before your scheduled court appearance, or immediately upon receiving this notification if the time before the scheduled appearance is less than seven (7) days; if you are hearing or voice impaired, call 711.

By: Andrew Unton, Esq.,
FBN: 100060
Mailing Address:
Morris|Hardwick|Schneider, LLC
5110 Eisenhower Blvd.,
Suite 302A
Tampa, Florida 33634
Customer Service (866)-503-4930
MHSinbox@closingsource.net
FL-97000152-12
10841247
May 30; June 6, 2014 14-02450S

FIRST INSERTION

AMENDED NOTICE OF FORECLOSURE SALE IN THE CIRCUIT COURT OF THE TWELFTH JUDICIAL CIRCUIT IN AND FOR SARASOTA COUNTY, FLORIDA

Case No: 2010-CA-012449-NC
CHRISTIANA TRUST, A DIVISION OF WILMINGTON SAVINGS FUND SOCIETY, FSB, AS TRUSTEE FOR STANWICH MORTGAGE LOAN TRUST, SERIES 2012-13, Plaintiff, vs. MAKSIM TKACHOU, ET AL., Defendants.

NOTICE IS HEREBY GIVEN that pursuant to the Final Judgment of Foreclosure dated March 17, 2014, and entered in Case No. 2010-CA-012449-NC of the Circuit Court of the Twelfth Judicial Circuit in and for Sarasota County, Florida wherein CHRISTIANA TRUST, A DIVISION OF WILMINGTON SAVINGS FUND SOCIETY, FSB, AS TRUSTEE FOR STANWICH MORTGAGE LOAN TRUST, SERIES 2012-13, is the Plaintiff and MAKSIM TKACHOU, ET AL, are the Defendant's, I will sell to the highest and best bidder for cash www.sarasota.realforeclose.com at 9:00 AM on June 13, 2014 the following described property set forth in said Final Judgment, to-wit:

LOT 22, BLOCK 1695, 36TH ADDITION TO PORT CHARLOTTE SUBDIVISION, A SUBDIVISION ACCORDING TO THE PLAT THEREOF AS RECORDED IN PLAT BOOK 16,

PAGES 3, 3A-3M, OF THE PUBLIC RECORDS OF SARASOTA COUNTY, FLORIDA.

Any person or entity claiming an interest in the surplus, if any, resulting from the Foreclosure Sale, other than the property owner as of the date of the Lis Pendens, must file a claim on same with the Clerk of Court within sixty (60) days after the Foreclosure Sale.

If you are a person with a disability who needs any accommodation in order to participate in this proceeding, you are entitled, at no cost to you, to the provision of certain assistance. Please contact the Sarasota County Jury Office, P.O. Box 3079, Sarasota, Florida 34230-3079, (941)861-7400, at least seven (7) days before your scheduled court appearance, or immediately upon receiving this notification if the time before the scheduled appearance is less than seven (7) days; if you are hearing or voice impaired, call 711.

DATED May 28, 2014

/s/ Nancy Alvarez
Nancy Alvarez, Esq.
Florida Bar No. 068122
Lender Legal Services, LLC
201 East Pine Street, Suite 730
Orlando, Florida 32801
Tel: (407) 730-4644
Fax: (888) 337-3815
Attorney for Plaintiff
nalvarez@lenderlegal.com
EService@LenderLegal.com
LLS00501-
May 30; June 6, 2014 14-02467S

FIRST INSERTION

NOTICE OF FORECLOSURE SALE PURSUANT TO CHAPTER 45 IN THE CIRCUIT COURT OF THE TWELFTH JUDICIAL CIRCUIT IN AND FOR SARASOTA COUNTY, FLORIDA

CASE NO. 2010CA3889NC
WELLS FARGO BANK, N.A. AS TRUSTEE FOR MASTR ASSET BACKED SECURITIES TRUST 2003-OPT1, MORTGAGE PASS-THROUGH CERTIFICATES, SERIES 2003-OPT1, Plaintiff(s), vs. CRISOFORO CORTES; et al., Defendant(s).

NOTICE IS HEREBY GIVEN that Sale will be made pursuant to an Order or Final Summary Judgment. Final Judgment was awarded on January 28, 2013 in Civil Case No.: 2010CA3889NC, of the Circuit Court of the TWELFTH Judicial Circuit in and for SARASOTA County, Florida, wherein, WELLS FARGO BANK, N.A. AS TRUSTEE FOR MASTR ASSET BACKED SECURITIES TRUST 2003-OPT1, MORTGAGE PASS-THROUGH CERTIFICATES, SERIES 2003-OPT1, is the Plaintiff, and, CRISOFORO CORTES; MARICELA CORTES; UNKNOWN TENANT A/K/A PEDRO CORTES, IF LIVING; AND UNKNOWN TENANT(S) IN POSSESSION are Defendants.

The clerk of the court, Karen E. Rushing, will sell to the highest bidder for cash online at www.sarasota.realforeclose.com at 9:00 AM on June 12, 2014, the following described real property as set forth in said Final summary Judgment, to-wit:

LOT 304, LESS WEST 3.3

FEET AND THE EAST 25.7 FEET THEREOF, EASTWOOD, UNIT 3, ACCORDING TO THE PLAT THEREOF, AS RECORDED IN PLAT BOK 10, PAGE 81 OF THE PUBLIC RECORDS OF SARASOTA COUNTY, FLORIDA

ANY PERSON CLAIMING AN INTEREST IN THE SURPLUS FROM THE SALE, IF ANY, OTHER THAN THE PROPERTY OWNER AS OF THE DATE OF THE LIS PENDENS MUST FILE A CLAIM WITHIN 60 DAYS AFTER THE SALE.

If you are a person with a disability who needs any accommodation in order to participate in this proceeding, you are entitled, at no cost to you, to the provision of certain assistance. Please contact the Sarasota County Jury Office, P.O. Box 3079, Sarasota, Florida 34230-3079, (941)861-7400, at least seven (7) days before your scheduled court appearance, or immediately upon receiving this notification if the time before the scheduled appearance is less than seven (7) days; if you are hearing or voice impaired, call 711.

Dated this 27 day of MAY, 2014.

BY: Nalini Singh
Fla. Bar #43700

Aldridge Connors, LLP
Attorney for Plaintiff(s)
1615 South Congress Avenue,
Suite 200
Delray Beach, FL 33445
Phone: 561.392.6391
Fax: 561.392.6965
Primary E-Mail:
ServiceMail@aqlawllp.com
1221-542B
May 30; June 6, 2014 14-02464S

FIRST INSERTION

NOTICE OF FORECLOSURE SALE IN THE CIRCUIT COURT OF THE TWELFTH JUDICIAL CIRCUIT IN AND FOR SARASOTA COUNTY, FLORIDA

CIVIL DIVISION
Case No. 08-18903-NC
Division A
WACHOVIA MORTGAGE, F.S.B. f/k/a WORLD SAVINGS BANK, F.S.B. Plaintiff vs. LEONID LEBED; et al. Defendant(s)

NOTICE IS HEREBY GIVEN pursuant to a Uniform Final Judgment of Foreclosure dated June 25, 2012, and entered in Case No. 2008 CA 018903 NC, Division A, of the Circuit Court for Sarasota County, Florida, the Office of the Clerk of the Court of Sarasota County, Florida, will sell to the highest and best bidder for cash at www.sarasota.realforeclose.com on the 10th day of September, 2014, at 9:00 a.m. or as soon as possible thereafter the following described property as set forth in said Summary Final Judgment:

LOTS 19524, 19525, 19526 and 19527, SOUTH VENICE, UNIT 75, ACCORDING TO THE PLAT THEREOF, AS RECORDED IN PLAT BOOK 7, PAGE 76, OF THE PUBLIC RECORDS OF SARASOTA COUNTY, FLORIDA.

Property Address: 450 Ponderosa Road, Venice, FL 34293.

**ANY PERSON CLAIMING AN INTEREST IN THE SURPLUS FROM THE SALE, IF ANY, OTHER THAN THE PROPERTY OWNER AS OF THE DATE OF LIS PENDENS MUST FILE A CLAIM WITHIN SIXTY (60) DAYS AFTER THE SALE. **

If you are a person with a dis-

ability who needs any accommodation in order to participate in this proceeding, you are entitled, at no cost to you, to the provision of certain assistance. Please contact the Sarasota County Jury Office, P.O. Box 3079, Sarasota, Florida 34230-3079, (941)861-7400, at least seven (7) days before your scheduled court appearance, or immediately upon receiving this notification if the time before the scheduled appearance is less than seven (7) days; if you are hearing or voice impaired, call 711.

Submitted to the Business Observer via e-mail this 27th day of May, 2014

/s/ Amy L. Drushal
DALE W. CRAVEY,
Florida Bar No. 0856428
dcravey@trenam.com/
ohoeppner@trenam.com
AMY L. DRUSHAL,
Florida Bar No. 0546895
adrushal@trenam.com/
lbehr@trenam.com
ROXANNE FIXSEN,
Florida Bar No. 0035733
rfixsen@trenam.com/
slord@trenam.com

TRENAM, KEMKER,
SCHARF, BARKIN,
FRYE, O'NEILL & MULLIS, P.A.
200 Central Avenue,
Suite 1600
St. Petersburg, FL 33701
Tel: 727-896-7171
Fax: 727-822-8048
Co-Counsel for Wells Fargo Bank, N.A. and
KJEL HORNELAND,
Florida Bar No. 76933
ALBERTELLI LAW
Post Office Box 23028
Tampa, FL 33623
servealaw@albertellilaw.com
Co-Counsel for Wells Fargo Bank, N.A.
8597720v1
May 30; June 6, 2014 14-02451S

PUBLISH YOUR LEGAL NOTICES
IN THE BUSINESS OBSERVER

(813) 221-9505 Hillsborough, Pasco

(727) 447-7784 Pinellas

(941) 906-9386 Manatee, Sarasota, Lee

(239) 263-0122 Collier

(941) 249-4900 Charlotte

(407) 654-5500 Orange

FIRST INSERTION

NOTICE OF ACTION IN THE CIRCUIT COURT OF THE TWELFTH JUDICIAL CIRCUIT, IN AND FOR SARASOTA COUNTY, FLORIDA

CASE NO.: 2014 CA 000439 NC HSBC BANK USA, NATIONAL ASSOCIATION, AS TRUSTEE FOR NOMURA ASSET ACCEPTANCE CORPORATION MORTGAGE PASS THROUGH CERTIFICATES SERIES 2005-AR3;

Plaintiff, vs. ELISABETH H. ARGUELLES A/K/A ELISABETH ARGUELLES; PETER ARGUELLES; ANY AND ALL UNKNOWN PARTIES CLAIMING BY, THROUGH, UNDER AND AGAINST THE HEREIN NAMED INDIVIDUAL DEFENDANT(S) WHO ARE NOT KNOWN TO BE DEAD OR ALIVE, WHETHER SAID UNKNOWN PARTIES MAY CLAIM AN INTEREST AS SPOUSES, HEIRS, DEVISEES, GRANTEEES, OR OTHER CLAIMANTS; GERALD J. SNYDER; FORD MOTOR CREDIT COMPANY, LLC; UNKNOWN TENANT #1 IN POSSESSION OF THE PROPERTY; UNKNOWN TENANT #2 IN POSSESSION OF THE PROPERTY;

Defendants. To the following Defendant(s): GERALD J. SNYDER Last Known Address 1048 ALLENDALE AVE S SARASOTA, FL 34237

YOU ARE NOTIFIED that an action for Foreclosure of Mortgage on the following described property:

LOT 14, BLOCK A, BAHIA VISTA HIGHLANDS, ACCORDING TO THE PLAT THEREOF RECORDED IN PLAT BOOK 1, PAGE 128 AND 129, OF THE PUBLIC RECORDS OF SARASOTA COUNTY, FLORIDA.

a/k/a 1048 ALLENDALE AVE S, SARASOTA, FL 34237 has been filed against you and you are required to serve a copy of your written defenses, if any, to it, on Marinosci Law Group, P.C., Attorney for Plaintiff, whose address is 100 W. Cypress Creek Road, Suite 1045, Fort Lauderdale, Florida 33309 on or before 6-30-2014, a date which is within thirty (30) days after the first publication of this Notice in the BUSINESS OBSERVER file the original with the Clerk of this Court either before service on Plaintiff's attorney, or immediately thereafter; otherwise a default will be entered against you for the relief demand in the complaint.

This notice is provided pursuant to Administrative Order No. 2.065.

If you are a person with a disability who needs any accommodation in order to participate in this proceeding, you are entitled, at no cost to you, to the provision of certain assistance. Please contact the Sarasota County Jury Office, P.O. Box 3079, Sarasota, Florida 34230-3079, (941)861-7400, at least seven (7) days before your scheduled court appearance, or immediately upon receiving this notification if the time before the scheduled appearance is less than seven (7) days; if you are hearing or voice impaired, call 711.

WITNESS my hand and the seal of this Court this 15 day of May, 2014.

KAREN E. RUSHING As Clerk of the Court (SEAL) By: G. Kopinsky As Deputy Clerk

Marinosci Law Group, P.C. 100 W. Cypress Creek Road, Suite 1045 Fort Lauderdale, FL 33309 Telephone: (954) 644-8704 Telefacsimile: (954) 772-9601 Our File Number: 13-13372 May 30; June 6, 2014 14-02351S

FIRST INSERTION

NOTICE OF ACTION FOR FORECLOSURE PROCEEDING-PROPERTY IN THE CIRCUIT COURT OF THE TWELFTH JUDICIAL CIRCUIT IN AND FOR SARASOTA COUNTY, FLORIDA

Case No.: 2014-CA-00629 NC Section: A

THIRD FEDERAL SAVINGS AND LOAN ASSOCIATION OF CLEVELAND Plaintiff, v.

UNKNOWN HEIRS, DEVISEES, GRANTEEES, LIENORS, AND OTHER PARTIES TAKING AN INTEREST UNDER CAROL ANN VIZZA, et al Defendant(s).

TO: UNKNOWN HEIRS, DEVISEES, GRANTEEES, LIENORS, AND OTHER PARTIES TAKING AN INTEREST UNDER CAROL ANN VIZZA, ADDRESS UNKNOWN BUT WHOSE LAST KNOWN ADDRESS IS: UNKNOWN

Residence unknown, if living, including any unknown spouse of the said Defendants, if either has remarried and if either or both of said Defendant(s) are dead, their respective unknown heirs, devisees, grantees, assignees, creditors, lienors, and trustees, and all other persons claiming by, through, under or against the named Defendant(s); and the aforementioned named Defendant(s) and such of the aforementioned unknown Defendants and such of the aforementioned unknown Defendant(s) as may be infants, incompetents or otherwise not sui juris.

YOU ARE HEREBY NOTIFIED that an action has been commenced to foreclose a mortgage on the following real property, lying and being and situated in Sarasota County, Florida, more particularly described as follows:

Lot 849, Villagewalk, Unit 4A,

according to the Plat thereof, as recorded in Plat Book 44, Pages 2 through 2D, inclusive, of the Public Records of Sarasota County, Florida COMMONLY KNOWN AS: 5401 Eliseo Street, Sarasota, FL 34238

This action has been filed against you and you are required to serve a copy of your written defense, if any, such as Morris Hardwick Schneider, LLC, Attorneys for Plaintiff, whose address is 5110 Eisenhower Blvd, Suite 302A, Tampa, FL 33634 on or before June 30th, 2014, and file the original with the clerk of this Court either before service on Plaintiff's attorney or immediately thereafter; otherwise a default will be entered against you for the relief demanded in the Complaint.

If you are a person with a disability who needs any accommodation in order to participate in this proceeding, you are entitled, at no cost to you, to the provision of certain assistance. Please contact the Sarasota County Jury Office, P.O. Box 3079, Sarasota, Florida 34230-3079, (941)861-7400, at least seven (7) days before your scheduled court appearance, or immediately upon receiving this notification if the time before the scheduled appearance is less than seven (7) days; if you are hearing or voice impaired, call 711.

WITNESS my hand and seal of this Court on the 21st day of May, 2014.

KAREN E. RUSHING, CLERK Clerk of the Circuit Court (SEAL) By: L. Szymanski Deputy Clerk

Morris | Hardwick | Schneider, LLC Attorneys for Plaintiff 5110 Eisenhower Blvd, Suite 302A, Tampa, FL 33634 FL-97003609-13 10621286 May 30; June 6, 2014 14-02371S

FIRST INSERTION

NOTICE OF SALE IN THE CIRCUIT COURT OF THE TWELFTH JUDICIAL CIRCUIT OF THE STATE OF FLORIDA, IN AND FOR SARASOTA COUNTY CIVIL DIVISION

CASE NO. 58-2012-CA-002658-0000-NC

BANK OF AMERICA, N.A. AS SUCCESSOR BY MERGER TO BAC HOME LOANS SERVICING, LP F/K/A COUNTRYWIDE HOME LOANS SERVICING, LP, Plaintiff, vs.

BRYAN T. PEYTON A/K/A BRYAN PEYTON; UNKNOWN SPOUSE OF BRYAN T. PEYTON A/K/A BRYAN PEYTON; AMBER N. VANSCHIVER A/K/A AMBER NADINE PEYTON; UNKNOWN SPOUSE OF AMBER N. VANSCHIVER A/K/A AMBER NADINE PEYTON; IF LIVING, INCLUDING ANY UNKNOWN SPOUSE OF SAID DEFENDANT(S), IF REMARRIED, AND IF DECEASED, THE RESPECTIVE UNKNOWN HEIRS, DEVISEES, GRANTEEES, ASSIGNEES, CREDITORS, LIENORS, AND TRUSTEES, AND ALL OTHER PERSONS CLAIMING BY, THROUGH, UNDER OR AGAINST THE NAMED DEFENDANT(S); CITY OF SARASOTA, FLORIDA; WHETHER DISSOLVED OR PRESENTLY EXISTING, TOGETHER WITH ANY GRANTEEES, ASSIGNEES, CREDITORS, LIENORS, OR TRUSTEES OF SAID DEFENDANT(S) AND ALL OTHER PERSONS CLAIMING BY, THROUGH, UNDER, OR AGAINST DEFENDANT(S); UNKNOWN TENANT #1; UNKNOWN TENANT #2; Defendant(s)

Notice is hereby given that, pursuant

to a Final Summary Judgment of Foreclosure entered on 02/11/2014 in the above styled cause, in the Circuit Court of Sarasota County, Florida, the office of Karen E. Rushing clerk of the circuit court will sell the property situate in Sarasota County, Florida, described as: Lot 44, Block 368, 10TH ADDITION TO PORT CHARLOTTE SUBDIVISION, according to the plat thereof, as recorded in Plat Book 12, Page 22, of the Public Records of Sarasota County, Florida.

at public sale, to the highest and best bidder, for cash, www.sarasota.real-foreclose.com at 9:00 o'clock, A.M., on June 11, 2014

Any person claiming an interest in the surplus from the sale, if any, other than the property owner as of the date of the lis pendens, must file a claim within 60 days after the sale.

If you are a person with a disability who needs any accommodation in order to participate in this proceeding, you are entitled, at no cost to you, to the provision of certain assistance. Please contact the Sarasota County Jury Office, P.O. Box 3079, Sarasota, Florida 34230-3079, (941)861-7400, at least seven (7) days before your scheduled court appearance, or immediately upon receiving this notification if the time before the scheduled appearance is less than seven (7) days; if you are hearing or voice impaired, call 711.

ATTORNEY FOR PLAINTIFF By /S/ Josh D. Donnelly Josh D. Donnelly Florida Bar #64788

Date: 05/19/2014 THIS INSTRUMENT PREPARED BY: Law Offices Of Daniel C. Consuegra 9204 King Palm Drive Tampa, FL 33619-1328 Phone: 813-915-8660 Attorneys for Plaintiff 121056 May 30; June 6, 2014 14-02342S

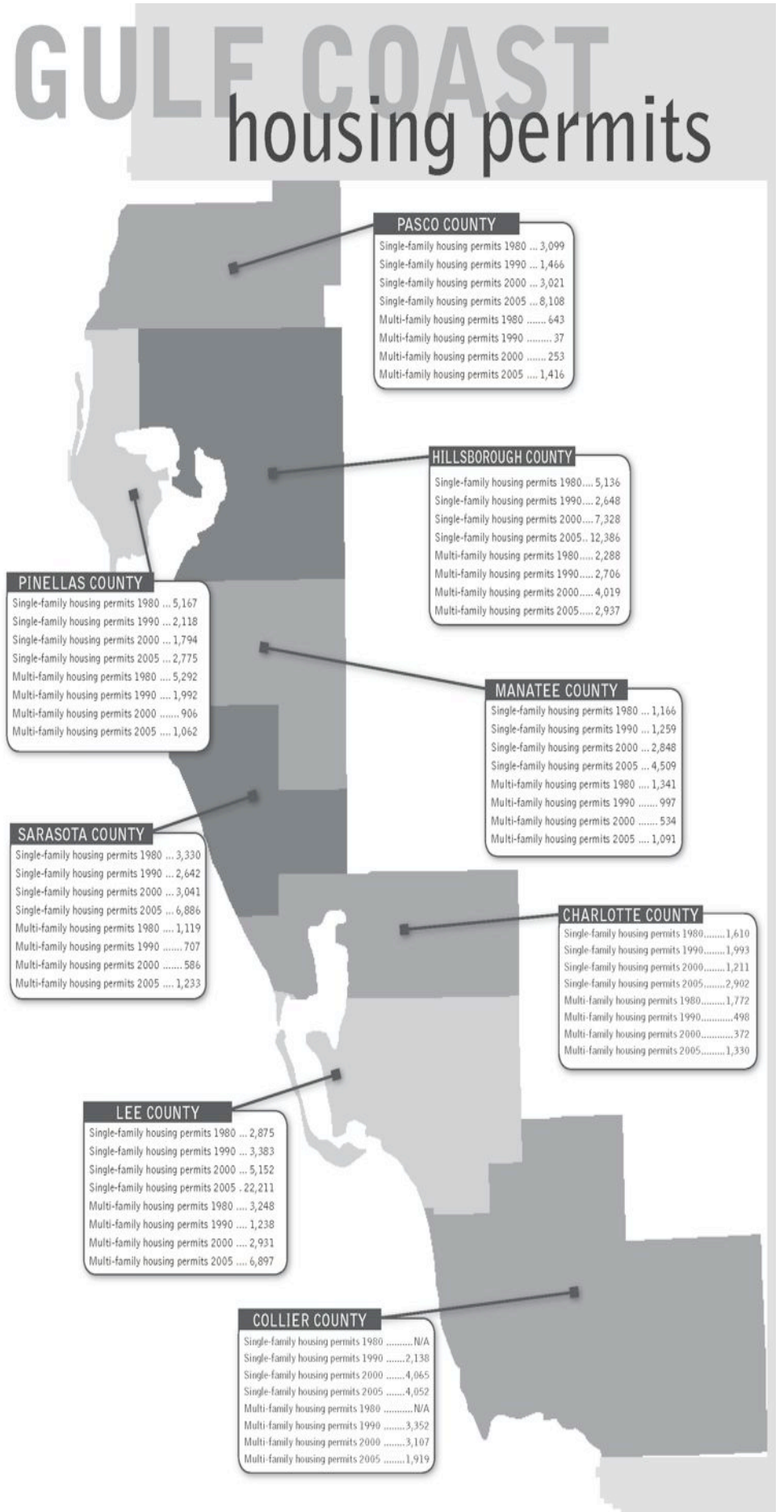
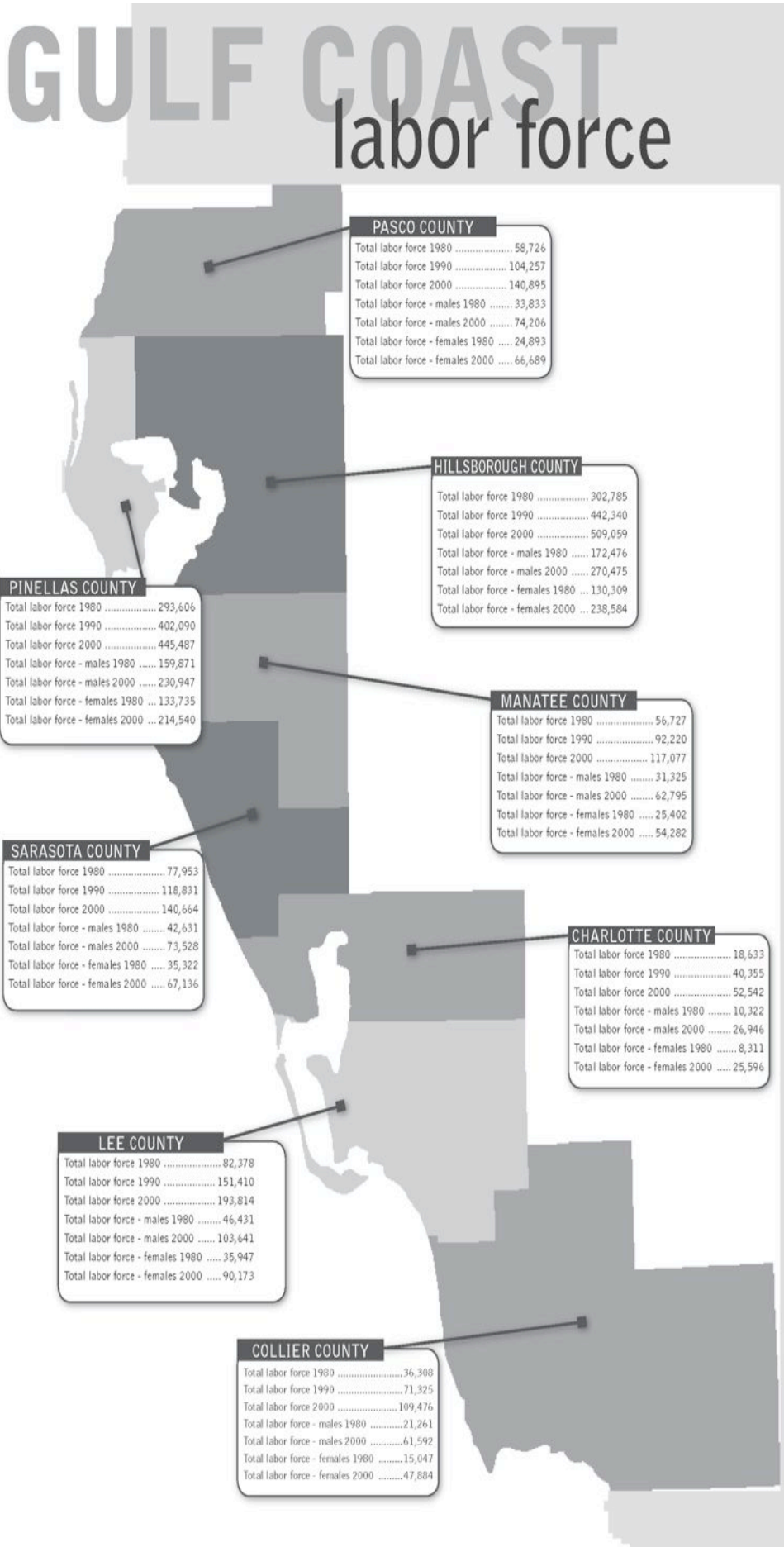

PUBLIC NOTICES

An American Tradition

Public notice is an important tool in assuring an informed citizenry. Notices are mandated by legislatures to make sure there is a public window into the activities of governments, officers of the court and others holding a public trust. There are four key elements to a valid public notice. It should be executed by an entity outside the one mandated to provide notice, so proper checks and balances are in place.

A public notice informs citizens of government or government-related activities that affect citizens' everyday lives. A public notice typically has four elements:

- **Independent:** A public notice is published in a forum independent of the government, typically in a local newspaper.
- **Archivable:** A public notice is archived in a secure and publicly available format.
- **Accessible:** A public notice is capable of being accessed by all segments of society.
- **Verifiable:** The public and the source of the notice are able to verify that the notice was published, usually by an affidavit provided by the publisher.

(Adapted from the Public Resource Notice Center)

Types of Public Notices

There are three standard types:

- **Citizen participation notices** inform the public about proposed government action and allow the public time to react to such proposals.

One such example is a public hearing notice.

- **Business and commerce notices**

relate to government contracts and purchases. Notices of contract bids allow citizens to ensure that the government is operating in accordance with principles of equal opportunity and is acting responsibly in spending taxpayer money.

- **Court notices** are required of many non-governmental entities that

use public powers or institutions in some way. Examples include notices of home mortgage foreclosures, which can provide a public alert of widespread credit problems, fraud in underwriting and a basis for analyses of housing trends.

This notice allows the public to object to an appointment based on any conflict of interest.

The history of public notices

Public notices existed long before the emergence of newspapers. The concept itself began when early civilizations posted notices in public squares. This crude method was eventually refined with the publication of the first English language newspaper in 1665 — a court newspaper called the Oxford Gazette. After being renamed The London Gazette, this official newspaper carried notices from the King's Court, London

officials and outlying regions.

The American system is modeled after the British system. State governments published public notices before America's founding, and the newly-created federal government followed suit. In 1789, the Acts of the First Congress required the Secretary of State to publish all bills, orders, resolutions and congressional votes in at least three publicly available newspapers.

An important premise both in federal

and local governments of the United States, as well as in many republics around the world, is that information about government activities must be accessible for the electorate to make well-informed decisions.

Public notices in newspapers still provide this accessibility to citizens who want to know more about government activities. Public notice laws serve to outline the most effective method of reaching the public.

Public notice supports due process

Public notices are integral to democratic governance and stem from the right to "due process of law" guaranteed by the federal and state constitutions. Due process of law protects Americans' rights from arbitrary or wrongful violations. This concept has two parts: substantive due process and procedural due process.

Substantive due process refers to the

types of rights that are protected. Procedural due process refers to the means of protecting those rights.

Substantive due process ensures that certain basic rights are not violated, while procedural due process may require suitable notice and a hearing before a government or court-appointed body can act in a way that may affect those basic rights.

Public notices play a vital role in

substantive and procedural due process because they provide a window into government actions and also afford notice to citizens of actions about to take place so they may exercise their constitutional right to be heard. Notification not only informs the individual or entity most directly affected, but it also informs the public, which has an interest in knowing how public powers are being used.

WHY NEWSPAPERS?

Newspapers are the primary source

Newspapers, founded on the constitutional right of free press, have been serving the public's right to know in America since pre-colonial times and on the European continent since the 17th century. Because of their traditional information role in society and their long-established independence, newspapers remain the primary source for publishing public notices.

Upholding the public's right to know is essential to our country's way of life. Our government governs with the consent of the people, and this consent must be informed. Local newspapers keep the public informed about the inner workings of their respective state and local governments, thereby allowing citizens to participate more fully in the democratic process. Without this participation, the potential for misguided policies increases.

Newspaper tradition

Newspapers allow the government to notify the public of government actions. The government has a fundamental responsibility to ensure adequate notification to the public of its actions. Therefore, the government has a duty to make sure the methods used in satisfying this responsibility are the most effective.

Newspapers provide neutrality from government and credible distance from political pressures or partisan disagreements. Local and community newspapers serve as third-party reporters to the public, publishing information that can be beneficial or sometimes detrimental to the government's public image. They provide an environment for notices that the

public traditionally has regarded as neutral. Public notices in this print environment gain credibility because of the long history of trust in the local newspaper.

Placing notices on government Web sites undermines this neutral interest and removes a critical check and balance. While it may seem appealing on the surface in an age of ever-more sophisticated government Web sites, the potential for mishandling is great.

On the other hand, public notices in independent newspapers increase government transparency by opening up the decision-making process to the public's eyes. Without this oversight, local governments could enact controversial policies without input from the public.

Newspapers serve as effective monitors of governments and ensure that they publish information as required by law. Public notices are typically required by a statute or a regulation. The independent press can provide a valuable civic role by helping to monitor that the notices were published when required. If governments were responsible for publishing their own notices, no neutral and independent entity would have the incentive and the means to track public-notice publication.

Newspapers: The best medium for public notices

Newspapers, for the most of the republic's history, have been the accepted medium for public notices. This is exactly where the public, even infrequent readers, expects to find them. In addition, specialized publications, such as legal newspapers, are well known for

providing public notices to the population through legal communities. Other general interest newspapers, such as county seat weeklies, are the forum where county citizens expect to locate notices of important public business. Furthermore, the vast majority of these notices arrive at citizens' homes in a context that compels readership (amid local news, sports features and other content).

Another reason for the effectiveness of newspapers is that newspapers provide valid evidence of readership.

Legislatures are rightly concerned about web-only notices, given the digital divide between rich and poor, rural and urban residents. The Internet is either too costly or simply geographically unavailable to large segments of society.

Notices become historical records

The newspaper as paper of record is an important factor in the public policy of notices. Government Web sites cannot provide a secure archival history the way newspapers can. Electronic records lack permanence and can easily be intentionally or accidentally erased. Even the Library of Congress has recognized this shortcoming and has embarked upon a major project to attempt to archive digital records that are in danger of being "forever lost" due to Internet impermanence.

Despite these problems, the federal courts unwisely approved a rule change to the Federal Rules of Civil Procedure recently that would

THE RISKS OF NOTICES ONLY ON THE INTERNET

Although it has been part of American society for a quarter-century as a network for scholars and government agencies, the Internet has been widely used by citizens for about 15 years.

Because of its structure with computer clients and servers, information packets and open-network codes, the Internet remains vulnerable and sometimes unstable. Power surges, corrupted software and downed servers can disrupt access. Government agencies cannot ensure that information located on a server is secure.

Even a highly technological site like that of the Pentagon's has been affected. In June 2007, the Pentagon was forced to take about 1,500 computers off-line because of a cyber-attack. Then-Defense Department Secretary Robert Gates stated that the Pentagon sees hundreds of attacks every day.

Public notices guard our constitutional right to due process of law by informing citizens of government action and providing proof of publication via notarized affidavits of publication. Unlike the time-tested and trusted local newspapers that citizens have come to rely on for public notices, the Internet is an unstable medium for information. While it is a valuable tool in disseminating information, it has not yet reached a level of sophistication and technological stability that would justify its supplanting newspapers as the primary venue for public notices.

It is still uncertain how a "Net" affidavit could show proof of a public notice publication when constant technological change makes any attempt at archiving and accessing such a document online for any significant time dubious.

No less problematic for the Internet is its reach. Those who live in rural areas where broadband does not exist and others who simply cannot afford the Internet cannot access web public notices. In situations where foreclosures are on the rise due, in part, to predatory mortgage lending, more, not less, access to public notices is needed to better inform citizens about their rights and their choices.

It is difficult to justify, then, moving public notices from newspapers only to public-notice Web sites administered either by already over-burdened state governments or by third-party vendors who lack the experience and long-term viability newspapers have proven in publishing notices.

So far in the Internet age, newspapers remain the most trusted and primary method for providing citizens access to public notices.

move notices of federal asset forfeitures out of newspapers and onto a Web site administered by the Department of Justice. Yet, the courts have little research to show that the Justice Department's Web site will produce viable, accessible, archivable notices.

While Internet web pages pose serious archiving challenges, newspapers, on the other hand, become historical documents. They are oriented and published with a date on every page. They cannot be deceptively altered after printing as a web page could. Historians, judges, lawyers, genealogists and researchers, to name only a few, use newspapers and public notices in particular as sources for records.

Newspaper notices protect due process

Procedural due process, as granted by the U.S. Constitution and interpreted

by courts, generally requires an individual to receive notice and a hearing before he or she is deprived of certain rights or property. For example, before a person's home is sold by a county sheriff at a foreclosure sale, he or she must receive notice of the foreclosure sale and an opportunity to save the house from foreclosure. If the owner does not receive the notice, he may challenge the sale in court. The court may then void the sale or prevent the sale from happening to protect due process.

Newspapers are generally paid to run public notices, which recognizes that their publication creates a cost in paper, ink and delivery.



SUBSEQUENT INSERTIONS

SECOND INSERTION

NOTICE OF FORECLOSURE SALE IN THE CIRCUIT COURT IN AND FOR SARASOTA COUNTY, FLORIDA

CASE NO: 2012 CA 003811 NC
GREEN TREE SERVICING LLC Plaintiff, vs. MICHELLE PHILLIPS; RODNEY SCHEELE; UNKNOWN SPOUSE OF MICHELLE PHILLIPS; UNKNOWN SPOUSE OF RODNEY SCHEELE; UNKNOWN TENANT I; UNKNOWN TENANT II; THE HOUSING AUTHORITY OF THE CITY OF SARASOTA, FLORIDA; SARASOTA COUNTY, A POLITICAL SUBDIVISION OF THE STATE OF FLORIDA, and any unknown heirs, devisees, grantees, creditors, and other unknown persons or unknown spouses claiming by, through and under any of the above-named Defendants, Defendants.

NOTICE is hereby given that the Clerk of the Circuit Court of Sarasota County, Florida, will on the 6th day of June, 2014, at 9:00 AM, at www.sarasota.realestate.com, in accordance with Chapter 45 Florida Statutes, offer for sale and sell at public outcry to the highest and best bidder for cash, the following-described property situate in Sarasota County, Florida:

LOT 1348, SARASOTA SPRINGS, UNIT NO. 12, ACCORDING TO THE PLAT THEREOF RECORDED IN PLAT BOOK 8, PAGE 42, OF THE PUBLIC RECORDS OF SARASOTA COUNTY, FLORIDA.

pursuant to the Final Judgment entered in a case pending in said Court, the style of which is indicated above.

Any person or entity claiming an interest in the surplus, if any, resulting from the foreclosure sale, other than the property owner as of the date of the Lis Pendens, must file a claim on same with the Clerk of Court within 60 days after the foreclosure sale.

If you are a person with a disability who needs any accommodation in order to participate in this proceeding, you are entitled, at no cost to you, to the provision of certain assistance. Please contact the Sarasota County Jury Office, P.O. Box 3079, Sarasota, Florida 34230-3079, (941)861-7400, at least seven (7) days before your scheduled court appearance, or immediately upon receiving this notification if the time before the scheduled appearance is less than seven (7) days; if you are hearing or voice impaired, call 711

DATED this 14 day of May, 2014.
Chris Bertels, Esquire
Florida Bar No: 98267
Amanda Ann Shough, Esquire
Florida Bar No: 107073

BUTLER & HOSCH, P.A.
3185 South Conway Road, Suite E
Orlando, Florida 32812
Telephone: (407) 381-5200
Fax: (407) 381-5577
Florida Bar No: 103300
as107073@butlerandhosch.com
FLPleadings@butlerandhosch.com
B&H # 312969
May 23, 30, 2014 14-02229S

SECOND INSERTION

NOTICE OF ACTION IN THE CIRCUIT COURT OF THE 12TH JUDICIAL CIRCUIT, IN AND FOR SARASOTA COUNTY, FLORIDA

CASE NO.: 2013 CA 003792 NC
FEDERAL NATIONAL MORTGAGE ASSOCIATION, Plaintiff, vs. UNKNOWN HEIRS, BENEFICIARIES, DEVISEES, ASSIGNEES, LIENORS, CREDITORS, TRUSTEES AND ALL OTHERS WHO MAY CLAIM AN INTEREST IN THE ESTATE OF FREDERICK EDWARD RUEGER, JR., et al., Defendants.

TO: UNKNOWN HEIRS, BENEFICIARIES, DEVISEES, ASSIGNEES, LIENORS, CREDITORS, TRUSTEES AND ALL OTHERS WHO MAY CLAIM AN INTEREST IN THE ESTATE OF FREDERICK EDWARD RUEGER, JR., et al.,

Last Known Address: UNKNOWN
Current Address: UNKNOWN
YOU ARE NOTIFIED that an action for Foreclosure of Mortgage on the following described property:

LOTS 17 AND 19, BLOCK E, OF RIDGEWOOD, ACCORDING TO THE PLAT THEREOF, RECORDED IN PLAT BOOK 1, PAGE 132, OF THE PUBLIC RECORDS OF SARASOTA COUNTY, FLORIDA

has been filed against you and you are required to serve a copy of your written defenses, if any, to it, on Choice Legal Group, P.A., Attorney for Plaintiff, whose address is P.O. BOX 9908, FT. LAUDERDALE, FL 33310-0908 on or before June 23rd, 2014, a date which is within thirty (30) days after the first publication of this Notice in the BUSINESS OBSERVER and file the original with the Clerk of this Court either before service on Plaintiff's attorney or immediately thereafter; otherwise a default will be entered against you for the relief demanded in the complaint.

If you are a person with a disability who needs any accommodation in order to participate in this proceeding, you are entitled, at no cost to you, to the provision of certain assistance. Please contact the Sarasota County Jury Office, P.O. Box 3079, Sarasota, Florida 34230-3079, (941)861-7400, at least seven (7) days before your scheduled court appearance, or immediately upon receiving this notification if the time before the scheduled appearance is less than seven (7) days; if you are hearing or voice impaired, call 711.

WITNESS my hand and the seal of this Court this 16th day of May, 2014.

KAREN E. RUSHING
As Clerk of the Court
(SEAL) By: L. Szymanski
As Deputy Clerk

Choice Legal Group, P.A.,
Attorney for Plaintiff
P.O. Box 9908
Fort Lauderdale, FL 33310-9908
12-08786
May 23, 30, 2014 14-02293S

SECOND INSERTION

NOTICE OF ACTION IN THE CIRCUIT COURT IN AND FOR SARASOTA COUNTY, FLORIDA

CASE NO: 2013 CA 007681 NC
NATIONSTAR MORTGAGE LLC D.B.A CHAMPION MORTGAGE COMPANY Plaintiff, vs. THE UNKNOWN HEIRS, DEVISEES, GRANTEES, ASSIGNEES, LIENORS, CREDITORS, TRUSTEES, AND OTHER UNKNOWN PERSONS OR UNKNOWN SPOUSES CLAIMING BY, THROUGH, UNDER OR AGAINST DESPINA SPYRIDAKOS, DECEASED, ET AL., Defendants.

TO: THE UNKNOWN HEIRS, DEVISEES, GRANTEES, ASSIGNEES, LIENORS, CREDITORS, TRUSTEES, AND OTHER UNKNOWN PERSONS OR UNKNOWN SPOUSES CLAIMING BY, THROUGH, UNDER OR AGAINST DESPINA SPYRIDAKOS, DECEASED
LAST KNOWN ADDRESS STATED, CURRENT RESIDENCE UNKNOWN
YOU ARE HEREBY NOTIFIED that an action to foreclose Mortgage covering the following real and personal property described as follows, to-wit:

LOT 11, BLOCK 27, SOUTH GATE, UNIT NO. 9, AS PER PLAT THEREOF RECORDED IN PLAT BOOK 8, PAGE 81, OF THE PUBLIC RECORDS OF SARASOTA COUNTY, FLORIDA.

has been filed against you and you are required to serve a copy of your written defenses, if any, to it on Amanda A. Shough, Butler & Hosch, P.A., 3185 South Conway Road, Suite E, Orlando, Florida 32812 and file the original with the Clerk of the above-styled Court on or before 30 days from the first publication, otherwise a Judgment may be entered against you for the relief demanded in the Complaint.

If you are a person with a disability who needs any accommodation in order to participate in this proceeding, you are entitled, at no cost to you, to the provision of certain assistance. Please contact the Sarasota County Jury Office, P.O. Box 3079, Sarasota, Florida 34230-3079, (941)861-7400, at least seven (7) days before your scheduled court appearance, or immediately upon receiving this notification if the time before the scheduled appearance is less than seven (7) days; if you are hearing or voice impaired, call 711.

WITNESS my hand and seal of said Court on the 12 day of May, 2014.

KAREN E. RUSHING, CLERK
CLERK OF THE CIRCUIT COURT
(COURT SEAL) By: G. Kopinsky
Deputy Clerk

Amanda A. Shough
Butler & Hosch, P.A.
3185 South Conway Road, Suite E
Orlando, Florida 32812
B&H # 337579
May 23, 30, 2014 14-02230S

SECOND INSERTION

NOTICE OF FORECLOSURE SALE IN THE CIRCUIT COURT OF THE TWELFTH JUDICIAL CIRCUIT IN AND FOR SARASOTA COUNTY, FLORIDA

Case No: 2013-CA-009023-NC
CHRISTIANA TRUST, A DIVISION OF WILMINGTON SAVINGS FUND SOCIETY, FSB, AS TRUSTEE FOR STANWICH MORTGAGE LOAN TRUST, SERIES 2012-13, Plaintiff, vs. GLENN WALTRIP, ET AL. Defendants.

NOTICE IS HEREBY GIVEN that pursuant the Final Judgment of Foreclosure dated May 12, 2014, and entered in Case No. 2013-CA-009023-NC of the Circuit Court of the Twelfth Judicial Circuit in and for Sarasota County, Florida wherein CHRISTIANA TRUST, A DIVISION OF WILMINGTON SAVINGS FUND SOCIETY, FSB, AS TRUSTEE FOR STANWICH MORTGAGE LOAN TRUST, SERIES 2012-13, is the Plaintiff and GLENN WALTRIP, ET AL., are the Defendant's, I will sell to the highest and best bidder for cash www.sarasota.realestate.com at 9:00 AM on or as soon as possible on June 18, 2014 the following described property set forth in said Final Judgment, to wit:

LOT 6, BLOCK 574, 18TH ADDITION TO PORT CHARLOTTE SUBDIVISION, A SUBDIVISION ACCORDING TO THE PLAT THEREOF, RECORDED IN PLAT BOOK 14, PAGES 6, 6A THROUGH 6V, OF THE PUBLIC RECORDS OF SARASOTA COUNTY, FLORIDA.

Any person or entity claiming an interest in the surplus, if any, resulting from the Foreclosure Sale, other than the property owner as of the date of the Lis Pendens, must file a claim on same with the Clerk of Court within sixty (60) days after the Foreclosure Sale.

If you are a person with a disability who needs any accommodation in order to participate in this proceeding, you are entitled, at no cost to you, to the provision of certain assistance. Please contact the Sarasota County Jury Office, P.O. Box 3079, Sarasota, Florida 34230-3079, (941)861-7400, at least seven (7) days before your scheduled court appearance, or immediately upon receiving this notification if the time before the scheduled appearance is less than seven (7) days; if you are hearing or voice impaired, call 711.

DATED May 13, 2014
/s/ Nancy Alvarez
Nancy Alvarez, Esq.
Florida Bar No. 068122

Lender Legal Services, LLC
201 East Pine Street, Suite 730
Orlando, Florida 32801
Tel: (407) 730-4644
Fax: (888) 337-3815
Attorney for Plaintiff
nalvarez@lenderlegal.com
EService@LenderLegal.com
May 23, 30, 2014 14-02231S

SECOND INSERTION

NOTICE OF ACTION IN THE CIRCUIT COURT OF THE TWELFTH JUDICIAL CIRCUIT IN AND FOR SARASOTA COUNTY, FLORIDA

Case No.: 2013-CA-008620
A/K/A DEBORAH S. ALDRIDGE Limited Liability Company Plaintiff, vs. CITY OF NORTH PORT, FLORIDA, ET AL., Defendants.

TO: DEBORAH SMITH ALDRIDGE A/K/A DEBORAH S. ALDRIDGE 1447 STRADA D ORO VENICE, FL 34292

YOU ARE HEREBY NOTIFIED that an action for foreclosure of lien on the following described property:

LOT 2, BLOCK 2499, FIFTEETH ADDITION TO PORT CHARLOTTE SUBDIVISION, A SUBDIVISION ACCORDING TO THE PLAT THEREOF, AS RECORDED IN PLAT BOOK 21, PAGES 7, 7A-7H, OF THE PUBLIC RECORDS OF SARASOTA COUNTY, FLORIDA.

Property Address: 5826 Gabo Road, North Port, FL 34287
Parcel ID: 1000-24-9902

Has been filed against you, and that you are required to serve a copy of your written defenses, if any, to it on STEVEN H. MEZER, ESQUIRE, Plaintiff's attorney, whose address is Bush Ross P.A., Post Office Box 3913, Tampa, FL 33601, on or before June 23, 2014, a date within 30 days after the first publication of the notice and file the original with the Clerk of this Court either before service on Plaintiff's attorney or immediately thereafter; otherwise a default will be entered against you for the relief demanded in the complaint or petition.

If you are a person with a disability who needs any accommodation in order to participate in this proceeding, you are entitled, at no cost to you, to the provision of certain assistance. Please contact the Sarasota County Jury Office, P.O. Box 3079, Sarasota, Florida 34230-3079, (941)861-7400, at least seven (7) days before your scheduled court appearance, or immediately upon receiving this notification if the time before the scheduled appearance is less than seven (7) days; if you are hearing or voice impaired, call 711.

DATED on May 9, 2014.

KAREN RUSHING
As Clerk of the Court
(SEAL) By C. Brandenburg
Deputy Clerk

Steven H. Mezer, Esquire
Florida Bar No. 239186
Bush Ross PA
P.O. Box 3913
Tampa, Florida 33601
(813) 204-6404
Attorney for Plaintiff
1661416v1
May 23, 30, 2014 14-02226S

SECOND INSERTION

NOTICE OF FORECLOSURE SALE IN THE CIRCUIT COURT OF THE TWELFTH JUDICIAL CIRCUIT IN AND FOR SARASOTA COUNTY, FLORIDA

CASE NO.: 58-2008-CA-019965-NC
DIVISION: A

THE BANK OF NEW YORK MELLON TRUST COMPANY NA, FKA THE BANK OF NEW YORK TRUST COMPANY, NA AS SUCCESSOR IN INTEREST TO JP MORGAN CHASE BANK, NA, AS TRUSTEE FOR NOMURA ASSET ACCEPTANCE CORPORATION, ALTERNATIVE LOAN TRUST SERIES 2005-AR2, Plaintiff, vs. RONALD C. SLOBODA, et al, Defendant(s).

NOTICE IS HEREBY GIVEN pursuant to a Final Judgment of Mortgage Foreclosure dated May 12, 2014 and entered in Case No. 58-2008-CA-019965-NC of the Circuit Court of the TWELFTH Judicial Circuit in and for SARASOTA County, Florida wherein THE BANK OF NEW YORK MELLON TRUST COMPANY NA, FKA THE BANK OF NEW YORK TRUST COMPANY, NA AS SUCCESSOR IN INTEREST TO JP MORGAN CHASE BANK, NA, AS TRUSTEE FOR NOMURA ASSET ACCEPTANCE CORPORATION, ALTERNATIVE LOAN TRUST SERIES 2005-AR2 is the Plaintiff and RONALD C SLOBODA; MORTGAGE ELECTRONIC REGISTRATION SYSTEMS, INCORPORATED, AS NOMINEE FOR FIRST GUARANTY MORTGAGE CORPORATION; are the Defendants, The Clerk will sell to the highest and best bidder for cash at WWW.SARASOTA.

required to file a copy of your written defenses, if any, to it, on IRA SCOT SILVERSTEIN, ESQUIRE, IRA SCOT SILVERSTEIN, LLC, Plaintiff's attorney, whose address is 2900 West Cypress Creek Road Suite 6, Fort Lauderdale, Florida 33309, within thirty (30) days after the first publication of this Notice, and file the original with the Clerk of this Court either before service on Plaintiff's attorney or immediately thereafter; otherwise a default will be entered against you for the relief demanded in the Complaint.

This Notice shall be published once each week for two consecutive weeks in the Business Observer.

If you are a person with a disability who needs any accommodation in order to participate in this proceeding, you are entitled, at no cost to you, to the provision of certain assistance. Please contact the Sarasota County Jury Office, P.O. Box 3079, Sarasota, Florida 34230-3079, (941)861-7400, at least seven (7) days before your scheduled court appearance, or immediately upon receiving this notification if the time before the scheduled appearance is less than seven (7) days; if you are hearing or voice impaired, call 711.

WITNESS my hand and seal of this Court this 13th day of May, 2014.

KAREN E. RUSHING, CLERK
Clerk of Court, Sarasota County
(Circuit Court Seal)
By: L. Szymanski
As Deputy Clerk
IRA SCOT SILVERSTEIN, ESQUIRE
IRA SCOT SILVERSTEIN, LLC
2900 West Cypress Creek Road
Suite 6,
Fort Lauderdale, Florida 33309
May 23, 30, 2014 14-02236S

SECOND INSERTION

NOTICE OF ACTION IN THE CIRCUIT COURT OF THE TWELFTH JUDICIAL CIRCUIT OF FLORIDA IN AND FOR SARASOTA COUNTY GENERAL JURISDICTION DIVISION

CASE NO. 58-2014-CA-001365 NC
GREEN TREE SERVICING LLC, Plaintiff, vs. WILLIAM G. TEETS, CHARLOTTE TEETS, UNKNOWN TENANT IN POSSESSION 1, UNKNOWN TENANT IN POSSESSION 2, Defendants.

TO: WILLIAM G. TEETS 3890 FROUDE STREET, NORTH PORT, FL 34286

LAST KNOWN ADDRESS STATED, CURRENT RESIDENCE UNKNOWN
YOU ARE NOTIFIED that an action to foreclose Mortgage covering the following real and personal property described as follows, to-wit:

LOTS 21 AND 22, BLOCK 529, 11TH ADDITION TO PORT CHARLOTTE SUBDIVISION, A SUBDIVISION ACCORDING TO THE PLAT THEREOF, AS RECORDED IN PLAT BOOK 13, AT PAGES 2, 2A THROUGH 2I, OF THE PUBLIC RECORDS OF SARASOTA COUNTY, FLORIDA.

has been filed against you and you are required to file a copy of your written defenses, if any, to it, on Brian Hummel, Esq., McCalla Raymer, LLC, 225 E. Robinson St. Suite 660, Orlando, FL 32801 and file the original with the Clerk of the above-styled Court on or before 30 days from the first publication, otherwise a Judgment may be entered against you for the relief demand in the Complaint.

If you are a person with a disability who needs any accommodation in order to participate in this proceeding, you are entitled, at no cost to you, to the provision of certain assistance. Please contact the Sarasota County Jury Office, P.O. Box 3079, Sarasota, Florida 34230-3079, (941)861-7400, at least seven (7) days before your scheduled court appearance, or immediately upon receiving this notification if the time before the scheduled appearance is less than seven (7) days; if you are hearing or voice impaired, call 711.

WITNESS my hand and seal of said Court on the 14th day of May, 2014.

KAREN E. RUSHING, CLERK
CLERK OF THE CIRCUIT COURT
As Clerk of the Court
(SEAL) BY: L. Szymanski
Deputy Clerk

MCCALLA RAYMER, LLC
225 E. Robinson St. Suite-660
Orlando, FL 32801
Phone: (407) 674-1850
Fax: (321) 248-0420
Email:
MRService@mccallaraymer.com
2806670
13-09612-1
May 23, 30, 2014 14-02233S

SECOND INSERTION

NOTICE OF ACTION IN THE CIRCUIT COURT OF THE TWELFTH JUDICIAL CIRCUIT IN AND FOR SARASOTA COUNTY, FLORIDA

CIVIL ACTION
CASE NO.: 58-2013-CA-007075 NC
WELLS FARGO BANK, N.A., Plaintiff, vs. SAM FARRA, et al, Defendant(s).

TO: SAM FARRA THE UNKNOWN SPOUSE OF SAM FARRA

Last Known Address: 7 Durie Lane Thornhill, Ontario L3T5H4
Current Address: Unknown
ANY AND ALL UNKNOWN PARTIES CLAIMING BY, THROUGH, UNDER, AND AGAINST THE HEREIN NAMED INDIVIDUAL DEFENDANT(S) WHO ARE NOT KNOWN TO BE DEAD OR ALIVE, WHETHER SAID UNKNOWN PARTIES MAY CLAIM AN INTEREST AS SPOUSES, HEIRS, DEVISEES, GRANTEES, OR OTHER CLAIMANTS

Last Known Address: Unknown
Current Address: Unknown
YOU ARE NOTIFIED that an action to foreclose a mortgage on the following property in Sarasota County, Florida:

LOT 21, BLOCK F, DESOTO ACRES, AS PER PLAT THEREOF, RECORDED IN PLAT BOOK 4, PAGES 41 AND 42, OF THE PUBLIC RECORDS OF SARASOTA COUNTY, FLORIDA.
A/K/A 53RD ST. LOT 21,

BLOCK F, SARASOTA, FL 34234

has been filed against you and you are required to serve a copy of your written defenses within 30 days after the first publication, if any, on Albertelli Law, Plaintiff's attorney, whose address is P.O. Box 23028, Tampa, FL 33623, and file the original with this Court either before June 16th, 2014 service on Plaintiff's attorney, or immediately thereafter; otherwise, a default will be entered against you for the relief demanded in the Complaint or petition.

This notice shall be published once a week for two consecutive weeks in the Business Observer.

If you are a person with a disability who needs any accommodation in order to participate in this proceeding, you are entitled, at no cost to you, to the provision of certain assistance. Please contact the Sarasota County Jury Office, P.O. Box 3079, Sarasota, Florida 34230-3079, (941)861-7400, at least seven (7) days before your scheduled court appearance, or immediately upon receiving this notification if the time before the scheduled appearance is less than seven (7) days; if you are hearing or voice impaired, call 711.

WITNESS my hand and the seal of this court on this 16th day of May, 2014.

KAREN E. RUSHING, CLERK
Clerk of the Circuit Court
(SEAL) By: L. Szymanski
Deputy Clerk

Albertelli Law
P.O. Box 23028
Tampa, FL 33623
EF-13-11136
May 23, 30, 2014 14-02291S

NOTICE OF ACTION IN THE CIRCUIT COURT OF THE TWELFTH JUDICIAL CIRCUIT IN AND FOR SARASOTA COUNTY, FLORIDA

Case No. 2014-CA-001199 NC
GREEN PLANET SERVICING, LLC, Plaintiff, vs. WILLIAM GLOVER; UNKNOWN SPOUSE OF WILLIAM GLOVER; et al, Defendant(s).

TO: UNKNOWN SPOUSE OF WILLIAM GLOVER 4037 Iola Drive Sarasota, FL 34231
If he/she/they are living and if he/she/they are dead, any unknown Defendants, who may be spouses, heirs, beneficiaries devisees, grantees, assignees, lienors, creditors, trustees, and all other parties claiming an interest by, through, under or against the named Defendant(s), who is/are not known to be dead or alive, and all parties having or claiming to have any right, title or interest in the property described in the mortgage being foreclosed herein.

YOU ARE HEREBY NOTIFIED that an action to foreclose a mortgage on the following real property in Sarasota County, Florida:
LOT 20, BLOCK "C" DIXIE HEIGHTS SUBDIVISION, ACCORDING TO THE PLAT THEREOF RECORDED IN PLAT BOOK 1 PAGE 147 PUBLIC RECORDS OF SARASOTA COUNTY, FLORIDA.

Commonly Known As: 4037 Iola Drive, Sarasota, FL 34231
has been filed against you and you are

SECOND INSERTION

NOTICE OF ACTION IN THE CIRCUIT COURT OF THE TWELFTH JUDICIAL CIRCUIT IN AND FOR SARASOTA COUNTY, FLORIDA

CIVIL ACTION
CASE NO.: 58-2008-CA-019965-NC
DIVISION: A

THE BANK OF NEW YORK MELLON TRUST COMPANY NA, FKA THE BANK OF NEW YORK TRUST COMPANY, NA AS SUCCESSOR IN INTEREST TO JP MORGAN CHASE BANK, NA, AS TRUSTEE FOR NOMURA ASSET ACCEPTANCE CORPORATION, ALTERNATIVE LOAN TRUST SERIES 2005-AR2, Plaintiff, vs. RONALD C. SLOBODA, et al, Defendant(s).

NOTICE IS HEREBY GIVEN pursuant to a Final Judgment of Mortgage Foreclosure dated May 12, 2014 and entered in Case No. 58-2008-CA-019965-NC of the Circuit Court of the TWELFTH Judicial Circuit in and for SARASOTA County, Florida wherein THE BANK OF NEW YORK MELLON TRUST COMPANY NA, FKA THE BANK OF NEW YORK TRUST COMPANY, NA AS SUCCESSOR IN INTEREST TO JP MORGAN CHASE BANK, NA, AS TRUSTEE FOR NOMURA ASSET ACCEPTANCE CORPORATION, ALTERNATIVE LOAN TRUST SERIES 2005-AR2 is the Plaintiff and RONALD C SLOBODA; MORTGAGE ELECTRONIC REGISTRATION SYSTEMS, INCORPORATED, AS NOMINEE FOR FIRST GUARANTY MORTGAGE CORPORATION; are the Defendants, The Clerk will sell to the highest and best bidder for cash at WWW.SARASOTA.

required to file a copy of your written defenses, if any, to it, on IRA SCOT SILVERSTEIN, ESQUIRE, IRA SCOT SILVERSTEIN, LLC, Plaintiff's attorney, whose address is 2900 West Cypress Creek Road Suite 6, Fort Lauderdale, Florida 33309, within thirty (30) days after the first publication of this Notice, and file the original with the Clerk of this Court either before service on Plaintiff's attorney or immediately thereafter; otherwise a default will be entered against you for the relief demanded in the Complaint.

This Notice shall be published once each week for two consecutive weeks in the Business Observer.

If you are a person with a disability who needs any accommodation in order to participate in this proceeding, you are entitled, at no cost to you, to the provision of certain assistance. Please contact the Sarasota County Jury Office, P.O. Box 3079, Sarasota, Florida 34230-3079, (941)861-7400, at least seven (7) days before your scheduled court appearance, or immediately upon receiving this notification if the time before the scheduled appearance is less than seven (7) days; if you are hearing or voice impaired, call 711.

WITNESS my hand and seal of this Court this 13th day of May, 2014.

KAREN E. RUSHING, CLERK
Clerk of Court, Sarasota County
(Circuit Court Seal)
By: L. Szymanski
As Deputy Clerk
IRA SCOT SILVERSTEIN, ESQUIRE
IRA SCOT SILVERSTEIN, LLC
2900 West Cypress Creek Road
Suite 6,
Fort Lauderdale, Florida 33309
May 23, 30, 2014 14-02236S

HOW TO PUBLISH YOUR LEGAL NOTICE IN THE BUSINESS OBSERVER

FOR MORE INFORMATION, CALL:
(813) 221-9505 Hillsborough, Pasco
(727) 447-7784 Pinellas
(941) 906-9386 Manatee, Sarasota, Lee
Or e-mail: legal@businessobserverfl.com
(239) 263-0122 Collier
(407) 654-5500 Orange
(941) 249-4900 Charlotte

SECOND INSERTION

NOTICE OF ACTION
IN THE CIRCUIT COURT OF THE
TWELFTH JUDICIAL CIRCUIT
IN AND FOR SARASOTA COUNTY,
FLORIDA

CIVIL ACTION
CASE NO.: 58-2013-CA-008482NC
DIVISION: A

WELLS FARGO BANK, N.A.,
Plaintiff, vs.
CHARLENE ANN
LATIMER-MACDONNELL, et al,
Defendant(s).

To:
CHARLENE ANN
LATIMER-MACDONNELL
THE UNKNOWN SPOUSE OF
CHARLENE ANN
LATIMER-MACDONNELL
RALSTON E. MACDONNELL
THE UNKNOWN SPOUSE OF
RALSTON E. MACDONNELL
Last Known Address: 1173 South Park
Street
Halifax, NS, B3H 2W9
Canada

Current Address: Unknown
ANY AND ALL UNKNOWN PARTIES CLAIMING BY, THROUGH, UNDER, AND AGAINST THE HEREIN NAMED INDIVIDUAL DEFENDANT(S) WHO ARE NOT KNOWN TO BE DEAD OR ALIVE, WHETHER SAID UNKNOWN PARTIES MAY CLAIM AN INTEREST AS SPOUSES, HEIRS, DEVISEES, GRANTEEES, OR OTHER CLAIMANTS

Last Known Address: Unknown
Current Address: Unknown

YOU ARE NOTIFIED that an action to foreclose a mortgage on the following property in Sarasota County, Florida:

UNIT NUMBER 1006, THE BEACHES OF LONGBOAT KEY SOUTH, PHASE I, A CONDOMINIUM ACCORDING TO THE DECLARATION OF CONDOMINIUM RECORDED IN OFFICIAL RECORDS BOOK 1647, PAGE

1812, AS AMENDED, AND AS PER PLAT THEREOF RECORDED IN CONDOMINIUM BOOK 21, PAGE 42, OF THE PUBLIC RECORDS OF SARASOTA COUNTY, FLORIDA. TOGETHER WITH PARKING SPACE NO. 239.
A/K/A 775 LONGBOAT KEY CLUB RD UNIT 1006, LONGBOAT KEY, FL 34228

has been filed against you and you are required to serve a copy of your written defenses within 30 days after the first publication, if any, on Albertelli Law, Plaintiff's attorney, whose address is P.O. Box 23028, Tampa, FL 33623, and file the original with this Court either before 6-23-14 service on Plaintiff's attorney, or immediately thereafter; otherwise, a default will be entered against you for the relief demanded in the Complaint or petition.

This notice shall be published once a week for two consecutive weeks in the Business Observer.

If you are a person with a disability who needs any accommodation in order to participate in this proceeding, you are entitled, at no cost to you, to the provision of certain assistance. Please contact the Sarasota County Jury Office, P.O. Box 3079, Sarasota, Florida 34230-3079, (941)861-7400, at least seven (7) days before your scheduled court appearance, or immediately upon receiving this notification if the time before the scheduled appearance is less than seven (7) days; if you are hearing or voice impaired, call 711.

WITNESS my hand and the seal of this court on this 13 day of May, 2014.

KAREN E. RUSHING, CLERK
Clerk of the Circuit Court
(SEAL) By: C. Brandenburg
Deputy Clerk

Albertelli Law
P.O. Box 23028
Tampa, FL 33623
JR-13-117526
May 23, 30, 2014 14-02223S

SECOND INSERTION

NOTICE OF ACTION
IN THE CIRCUIT COURT OF THE
TWELFTH JUDICIAL CIRCUIT
IN AND FOR SARASOTA COUNTY,
FLORIDA

CIVIL ACTION
CASE NO.: 58-2014-CA-000778 NC
DIVISION: C

THE BANK OF NEW YORK
MELLON F/K/A THE BANK OF
NEW YORK, AS
SUCCESSOR-IN-INTEREST TO
JPMORGAN CHASE BANK, N.A.,
F/K/A JPMORGAN CHASE BANK
AS TRUSTEE FOR STRUCTURED
ASSET MORTGAGE
INVESTMENTS II INC.,
GREENPOINT MTA TRUST
2005-ARI, MORTGAGE
PASS-THROUGH CERTIFICATES,
SERIES 2005-ARI,
Plaintiff, vs.
DSM, LLC, et al,
Defendant(s).

To:
JOHN DESYLVESTER
Last Known Address: 2601 Gulf Drive
North Lot S2
Bradenton Beach, FL 34217

Current Address: Unknown
ANY AND ALL UNKNOWN PARTIES CLAIMING BY, THROUGH, UNDER, AND AGAINST THE HEREIN NAMED INDIVIDUAL DEFENDANT(S) WHO ARE NOT KNOWN TO BE DEAD OR ALIVE, WHETHER SAID UNKNOWN PARTIES MAY CLAIM AN INTEREST AS SPOUSES, HEIRS, DEVISEES, GRANTEEES, OR OTHER CLAIMANTS

Last Known Address: Unknown
Current Address: Unknown

YOU ARE NOTIFIED that an action to foreclose a mortgage on the following property in Sarasota County, Florida:

LOT 10, LESS THE NORTH 10 INCHES OF LOT 10, BLOCK A, DESOTO TERRACE, BEING

A SUBDIVISION OF LOTS 53, 69, AND 73, INDIAN BEACH, ACCORDING TO THE PLAT THEREOF AS RECORDED IN PLAT BOOK A, PAGE 43, OF THE PUBLIC RECORDS OF SARASOTA COUNTY, FLORIDA

A/K/A 3804 IROQUOIS DR, SARASOTA, FL 34234
has been filed against you and you are required to serve a copy of your written defenses within 30 days after the first publication, if any, on Albertelli Law, Plaintiff's attorney, whose address is P.O. Box 23028, Tampa, FL 33623, and file the original with this Court either before 6-23-2014, service on Plaintiff's attorney, or immediately thereafter; otherwise, a default will be entered against you for the relief demanded in the Complaint or petition.

This notice shall be published once a week for two consecutive weeks in the Business Observer.

If you are a person with a disability who needs any accommodation in order to participate in this proceeding, you are entitled, at no cost to you, to the provision of certain assistance. Please contact the Sarasota County Jury Office, P.O. Box 3079, Sarasota, Florida 34230-3079, (941)861-7400, at least seven (7) days before your scheduled court appearance, or immediately upon receiving this notification if the time before the scheduled appearance is less than seven (7) days; if you are hearing or voice impaired, call 711.

WITNESS my hand and the seal of this court on this 12 day of May, 2014.

KAREN E. RUSHING, CLERK
Clerk of the Circuit Court
(SEAL) By: L. Szymanski
Deputy Clerk

Albertelli Law
P.O. Box 23028
Tampa, FL 33623
PH-13-119302
May 23, 30, 2014 14-02222S

SECOND INSERTION

NOTICE OF ACTION
IN THE CIRCUIT COURT OF THE
TWELFTH JUDICIAL CIRCUIT
IN AND FOR SARASOTA COUNTY,
FLORIDA

CIVIL DIVISION
CASE NO.: 58-2013-CA-005835 NC
DIVISION: C

ONEWEST BANK, F.S.B.
Plaintiff, v.
LAURIE A. MANJUCK;
ALEXANDER G. MANJUCK, III;
ROBERT RANDALL; WILLIAM
RANDALL; UNITED STATES OF
AMERICA, ACTING ON BEHALF
OF THE SECRETARY OF
HOUSING AND URBAN
DEVELOPMENT; DISCOVER
BANK; UNKNOWN TENANT #1;
UNKNOWN TENANT #2; ALL
OTHER UNKNOWN PARTIES
CLAIMING INTERESTS BY,
THROUGH, UNDER, AND
AGAINST A NAMED
DEFENDANT(S) WHO ARE NOT
KNOWN TO BE DEAD OR ALIVE,
WHETHER SAME UNKNOWN
PARTIES MAY CLAIM AN
INTEREST AS SPOUSES, HEIRS,
DEVISEES, GRANTEEES, OR
OTHER CLAIMANTS,
Defendant(s),
TO: ROBERT RANDALL

Last Known Address: 637 Flamingo
Road
Venice, Florida 34293
Current Address: Unknown
Previous Address: Unknown
TO: WILLIAM RANDALL
Last Known Address: 637 Flamingo
Road
Venice, Florida 34293
Current Address: Unknown
Previous Address: Unknown

TO: ALL OTHER UNKNOWN PARTIES CLAIMING INTERESTS BY, THROUGH, UNDER, AND AGAINST A NAMED DEFENDANT(S) WHO ARE NOT KNOWN TO BE DEAD OR ALIVE, WHETHER SAME UNKNOWN PARTIES MAY CLAIM AN INTEREST AS SPOUSES, HEIRS, DEVISEES, GRANTEEES, OR OTHER CLAIMANTS

whose residence is unknown if he/she/they be living; and if he/she/they be dead, the unknown Defendants who may be spouses, heirs, devisees, grantees, assignees, lienors, creditors, trustees, and all parties claiming an interest by, through, under or against the Defendants, who are not known to be dead or alive, and all parties having or claiming to have any right, title or interest in the property described in the mortgage being foreclosed herein

SECOND INSERTION

NOTICE OF ACTION
IN THE CIRCUIT COURT OF THE
TWELFTH JUDICIAL CIRCUIT
IN AND FOR SARASOTA COUNTY,
FLORIDA

CIVIL ACTION
CASE NO.: 58-2014-CA-00762 NC
BANK OF NEW YORK MELLON
AS TRUSTEE CWMBS
2005-HYB10,
Plaintiff, vs.

JOSEPH E. MILES A/K/A JOSEPH
MILES, et al,
Defendant(s).

To:
JOSEPH E. MILES A/K/A JOSEPH
MILES

THE UNKNOWN SPOUSE OF JOSEPH E. MILES A/K/A JOSEPH MILES

Last Known Address: 1840 Ridgewood
Lane East
Glenview, FL 60025

Current Address: Unknown

ANY AND ALL UNKNOWN PARTIES CLAIMING BY, THROUGH, UNDER, AND AGAINST THE HEREIN NAMED INDIVIDUAL DEFENDANT(S) WHO ARE NOT KNOWN TO BE DEAD OR ALIVE, WHETHER SAID UNKNOWN PARTIES MAY CLAIM AN INTEREST AS SPOUSES, HEIRS, DEVISEES, GRANTEEES, OR OTHER CLAIMANTS

Last Known Address: Unknown
Current Address: Unknown

YOU ARE NOTIFIED that an action to foreclose a mortgage on the following property in Sarasota County, Florida:

UNIT 704-S, CRESCENT ARMS, A CONDOMINIUM, TOGETHER WITH AN UNDIVIDED INTEREST IN THE COMMON ELEMENTS APPURTENANT THERETO, ACCORDING TO THE DECLARATION OF CONDOMINIUM THEREOF, AS RECORDED IN OFFICIAL RECORDS

BOOK 735, AT PAGE 47, TOGETHER WITH THE PLAT THEREOF, RECORDED IN CONDOMINIUM BOOK 2, PAGES 39 & 39A, ALL OF THE PUBLIC RECORDS OF SARASOTA COUNTY, FLORIDA, TOGETHER WITH ANY AMENDMENTS THERETO.
A/K/A 6312 MIDNIGHT PASS ROAD, 704-S; SARASOTA, FL 34242

has been filed against you and you are required to serve a copy of your written defenses within 30 days after the first publication, if any, on Albertelli Law, Plaintiff's attorney, whose address is P.O. Box 23028, Tampa, FL 33623, and file the original with this Court either before 6-23-2014 service on Plaintiff's attorney, or immediately thereafter; otherwise, a default will be entered against you for the relief demanded in the Complaint or petition.

This notice shall be published once a week for two consecutive weeks in the Business Observer.

If you are a person with a disability who needs any accommodation in order to participate in this proceeding, you are entitled, at no cost to you, to the provision of certain assistance. Please contact the Sarasota County Jury Office, P.O. Box 3079, Sarasota, Florida 34230-3079, (941)861-7400, at least seven (7) days before your scheduled court appearance, or immediately upon receiving this notification if the time before the scheduled appearance is less than seven (7) days; if you are hearing or voice impaired, call 711.

WITNESS my hand and the seal of this court on this 12 day of May, 2014.

Clerk of the Circuit Court
(SEAL) By: G. Kopinsky
Deputy Clerk

Albertelli Law
P.O. Box 23028
Tampa, FL 33623
JR-13-113196
May 23, 30, 2014 14-02221S

SECOND INSERTION

NOTICE OF ACTION
IN THE CIRCUIT COURT OF THE
TWELFTH JUDICIAL CIRCUIT OF
THE STATE OF FLORIDA, IN AND
FOR SARASOTA COUNTY
CIVIL DIVISION

CASE NO. 58-2012-CA-004383 NC
CITIMORTGAGE, INC.,
Plaintiff, vs.

LINDA BURCHFIELD ALSO
KNOWN AS LINDA SUE
BURCHFIELD, THE UNKNOWN
SPOUSE OF LINDA BURCHFIELD
ALSO KNOWN AS LINDA SUE
BURCHFIELD, CHRISTOPHER
BURCHFIELD, ANY AND ALL
UNKNOWN PARTIES CLAIMING
BY, THROUGH, UNDER, AND
AGAINST THE HEREIN NAMED
INDIVIDUAL DEFENDANT(S)
WHO ARE NOT KNOWN TO BE
DEAD OR ALIVE, WHETHER
SAID UNKNOWN PARTIES
MAY CLAIM AN INTEREST AS
SPOUSES, HEIRS, DEVISEES,
GRANTEEES OR OTHER
CLAIMANTS. TENANT # 1,
TENANT # 2, TENANT # 3 AND
TENANT # 4
Defendant(s).

TO: LINDA BURCHFIELD A/K/A
LINDA SUE BURCHFIELD; UN-
KNOWN SPOUSE OF LINDA
BURCHFIELD A/K/A LINDA SUE
BURCHFIELD

Whose residence(s) is/are unknown.

YOU ARE HEREBY required to file your answer or written defenses, if any, in the above proceeding with the Clerk of this Court, and to serve a copy thereof upon the plaintiff's attorney, Law Offices of Daniel C. Consuegra, 9204 King Palm Drive, Tampa, FL 33619-1328, telephone (813) 915-8660, facsimile (813) 915-0559, within thirty days of the first publication of this Notice, the nature of this proceeding being a suit for foreclosure of mortgage against the following described property, to

wit:

Lot 8, PERRY LANE SUBDIVISION, according to the plat thereof, as recorded in Plat Book 28, Page 8, of the Public Records of Sarasota County, Florida.

If you fail to file your response or answer, if any, in the above proceeding with the Clerk of this Court, and to serve a copy thereof upon the plaintiff's attorney, Law Offices of Daniel C. Consuegra, 9204 King Palm Drive, Tampa, Florida 33619-1328, telephone (813) 915-8660, facsimile (813) 915-0559, within thirty days of the first publication of this Notice, a default will be entered against you for the relief demanded in the Complaint or petition.

If you are a person with a disability who needs any accommodation in order to participate in this proceeding, you are entitled, at no cost to you, to the provision of certain assistance. Please contact the Sarasota County Jury Office, P.O. Box 3079, Sarasota, Florida 34230-3079, (941)861-7400, at least seven (7) days before your scheduled court appearance, or immediately upon receiving this notification if the time before the scheduled appearance is less than seven (7) days; if you are hearing or voice impaired, call 711.

DATED AT SARASOTA COUNTY this 12th day of May, 2014.

KAREN E. RUSHING, CLERK
Clerk of the Circuit Court
(SEAL) By: L. Szymanski
Deputy Clerk

Law Offices of
Daniel C. Consuegra
9204 King Palm Drive
Tampa, FL 33619-1328
telephone (813) 915-8660
facsimile (813) 915-0559
File No. 153037-T/Seterus, Inc./
Burchfield, Christopher & Linda/lpd
May 23, 30, 2014 14-02228S

proceeding, you are entitled, at no cost to you, to the provision of certain assistance. Please contact the Sarasota County Jury Office, P.O. Box 3079, Sarasota, Florida 34230-3079, (941)861-7400, at least seven (7) days before your scheduled court appearance, or immediately upon receiving this notification if the time before the scheduled appearance is less than seven (7) days; if you are hearing or voice impaired, call 711.

WITNESS my hand and the seal of the court on May 8, 2014.

KAREN E. RUSHING
CLERK OF THE COURT
(COURT SEAL) By: C. Brandenburg
Deputy Clerk

Attorney for Plaintiff:
Jacqueline Gardiner, Esq.
Arlisa Certain, Esq.
Elizabeth R. Wellborn, P.A.
350 Jim Moran Blvd.,
Suite 100
Deerfield Beach, FL 33442
Telephone: (954) 354-3544
Facsimile: (954) 354-3545
Primary email:
jgardiner@erlaw.com
Secondary email:
servicecomplete@erlaw.com
2012-15782
May 23, 30, 2014 14-02239S

SECOND INSERTION

NOTICE OF ACTION
IN THE CIRCUIT COURT OF THE
TWELFTH JUDICIAL CIRCUIT
IN AND FOR SARASOTA COUNTY,
FLORIDA

CIVIL ACTION
CASE NO.: 58-2013-CA-004671-NC
DIVISION: A

NATIONSTAR MORTGAGE LLC,
Plaintiff, vs.
JOSEPH R. MERCIER, et al,
Defendant(s).

TO:

THE UNKNOWN BENEFICIARY
OF THE WHILHELMINA L. MER-
CIER REVOCABLE TRUST UN-
DER TRUST AGREEMENT DATED
MARCH 29, 1991 A/K/A THE WHIL-
HELMINA L. MERCIER LIVING
TRUST DATED MARCH 29, 1991

LAST KNOWN ADDRESS: UN-
KNOWN

CURRENT ADDRESS: UNKNOWN
THE UNKNOWN HEIRS, DEVISEES,
GRANTEES, ASSIGNEES, LIENORS,
CREDITORS, TRUSTEES, OR OTHER
CLAIMANTS CLAIMING BY,
THROUGH, UNDER, OR AGAINST
WHILHELMINA L. MERCIER
A/K/A WHILHELMINA LOUISE
MERCIER, DECEASED

LAST KNOWN ADDRESS: UN-
KNOWN

CURRENT ADDRESS: UNKNOWN
ANY AND ALL UNKNOWN PARTIES CLAIMING BY, THROUGH, UNDER, AND AGAINST THE HEREIN NAMED INDIVIDUAL DEFENDANT(S) WHO ARE NOT KNOWN TO BE DEAD OR ALIVE, WHETHER SAID UNKNOWN PARTIES MAY CLAIM AN INTEREST AS SPOUSES, HEIRS, DEVISEES, GRANTEEES, OR OTHER CLAIMANTS

LAST KNOWN ADDRESS: UN-
KNOWN

CURRENT ADDRESS: UNKNOWN

YOU ARE NOTIFIED that an action to foreclose a mortgage on the following property in SARASOTA County, Florida:

UNIT 28, SAINT GEORGE AT THE PLANTATION, A CONDOMINIUM ACCORDING TO THE DECLARATION OF CONDOMINIUM RECORDED IN OFFICIAL RECORDS BOOK 1862, PAGE 1726, AND

THIRD INSERTION

NOTICE OF SHERIFF'S SALE

NOTICE is hereby given that pursuant to a Writ of Execution issued in the County Court of Sarasota County, Florida, on the 4th day of March, 2014, in the cause wherein CACH, LLC, Plaintiff, and Barbara M. Mayo, Defendant, being case number 13SC5769SC, in said Court, I, Thomas M. Knight, as Sheriff of Sarasota County, Florida, have levied upon all the right, title and interest of the Defendant, Barbara M. Mayo, in and to the following described personal property, to-wit:

2005 GM SIERRA 1500
VIN: 2GTCE13TX51189678

I shall offer this property for sale at 2071 Ringling Blvd Sarasota, FL 34237, County of Sarasota, Florida, on June 17, 2014, at the hour of 1:00 p.m., or as soon thereafter as possible. I will offer for sale all of the said Defendant's, Barbara M. Mayo, right, title, and interest in the aforesaid personal property, at public auction and will sell the same, subject to taxes, all prior liens, encumbrances and judgments, if any, to the highest and best bidder for CASH IN HAND. The moneys received through the levy on sale will be paid as prescribed by F.S.S. 56.27, and in accordance with the American Disabilities Act, persons needing a special accommodation to participate in this proceeding shall contact the individual or agency sending notice not later than seven days prior to the proceeding at the address given on notice. Telephone 941-861-4110. Vehicle may be viewed the same day of the sale between the hours of 11:30 am & 12:30 pm at Upman's Towing 2175 12th St. Sarasota, FL 34236.

Thomas M. Knight, Sheriff
Sarasota County, Florida
By: Sgt. R. Beasley #476
May 16, 23 & 30; June 6, 2014
14-02158S

THIRD INSERTION

NOTICE OF SHERIFF'S SALE

NOTICE is hereby given that pursuant to a Writ of Execution issued in the Circuit Court of Sarasota County, Florida, on the 1st day of April, 2014, in the cause wherein Joan Engelbach, Plaintiff, and James A. Graham and Doiana I. Graham, et al, Defendants, being case number 12CA4258NC, in said Court, I, Thomas M. Knight, as Sheriff of Sarasota County, Florida, have levied upon all the right, title and interest of the Defendants, James A. Graham and Doiana I. Graham, in and to the following described real properties, to-wit:

Lot 3, Block D, EDgewater, as per plat or map thereof recorded in Plat Book 1, Page 160 of the Public Records of Sarasota County, Florida.
Street Address: 2023 Coconut Avenue, Sarasota, FL 34234
Lot 22, Block C, NEWTOWN HEIGHTS, as per plat or map thereof recorded in Plat Book 1, Page 199 of the Public Records of Sarasota County, Florida.
Street Address: 2913 Church Ave., Sarasota, FL 34234

AS AMENDED, AND AS PER THE PLAT THEREOF RECORDED IN CONDOMINIUM BOOK 25, PAGE 43, OF THE PUBLIC RECORDS OF SARASOTA COUNTY, FLORIDA.

TOGETHER WITH AN UNDIVIDED INTEREST IN THE COMMON ELEMENTS APPURTENANT THERETO AS SET FORTH IN SAID DECLARATION

has been filed against you and you are required to serve a copy of your written defenses within 30 days after the first publication, if any, on Ronald R Wolfe & Associates, P.L., Plaintiff's attorney, whose address is 4919 Memorial Highway, Suite 200, Tampa, Florida 33634, and file the original with this Court either before service on Plaintiff's attorney or immediately thereafter; otherwise a default will be entered against you for the relief demanded in the Complaint or petition.

This notice shall be published once each week for two consecutive weeks in the Business Observer.

If you are a person with a disability who needs any accommodation in order to participate in this proceeding, you are entitled, at no cost to you, to the provision of certain assistance. Please contact the Sarasota County Jury Office, P.O. Box 3079, Sarasota, Florida 34230-3079, (941)861-7400, at least seven (7) days before your scheduled court appearance, or immediately upon receiving this notification if the time before the scheduled appearance is less than seven (7) days; if you are hearing or voice impaired, call 711.

WITNESS my hand and the seal of this Court on this 14 day of May, 2014.

Karen E. Rushing
Clerk of the Court
(SEAL) By: L. Szymanski
As Deputy Clerk

Ronald R Wolfe & Associates, P.L.,
Plaintiff's Attorney,
P.O. Box 25018
Tampa, Florida 33622-5018
F13003935
May 23, 30, 2014 14-02240S

THIRD INSERTION

NOTICE OF APPLICATION FOR
TAX DEED

Notice is hereby given that CITRUS CAPITAL LLC - SERIES 44 US BANK % CITRUS CAPITAL LLC, the holder of the certificate listed below, has filed said certificate for a tax deed to be issued. The certificate number and year of issuance, the description of the property, and the names in which the property is assessed are as follows:

Certificate Number: 3899.000
Year of Issuance: 2012
Tax Deed File #: 14-0047 TD

Description of Property: 0591031770 LOT 177 LESS PORTION DESC AS, BEG AT MOST ELY COR OF SAID LOT 177, SAID COR BEING ON C/L OF ROCKING HORSE LN, TH S-53-34-01-W 419.14 FT TH N-28-19-02-W 161.62 FT TH N-53-43-01-E 396.32 FT TH S-36-25-59-E 160 FT TO POB, MYAKKA VALLEY RANCHES UNIT 4, CONTAINING 5 C-AC M/L Name in which the property is assessed: ALLIE M MULLINNIX

All of said property being in the County of Sarasota, State of Florida. Unless the certificate is redeemed according to law, the property described in the certificate will be sold to the highest bidder at the Sarasota County Court House, 2000 Main Street, Historic Courtroom, East Wing, Sarasota, Florida, at 9:00 a.m. on the 17TH day of JUNE, 2014.

Karen E. Rushing
Clerk Of The Circuit Court
Sarasota County, Florida
By: T. Lake, Deputy Clerk

Publication Dates: MAY 16, 23, 30;
JUNE 6, 2014

14-02194S

THIRD INSERTION

I shall offer these properties for sale at 2071 Ringling Blvd Sarasota, FL 34237, County of Sarasota, Florida, on June 16, 2014, at the hour of 1:00 p.m., or as soon thereafter as possible. I will offer for sale all of the said Defendant's, James A. Graham and Doiana I. Graham, right, title, and interest in the aforesaid real properties, at public auction and will sell the same, subject to taxes, all prior liens, encumbrances and judgments, if any, to the highest and best bidder for CASH IN HAND. The moneys received through the levy on sale will be paid as prescribed by F.S.S. 56.27 and in accordance with the American Disabilities Act, persons needing a special accommodation to participate in this proceeding shall contact the individual or agency sending notice not later than seven days prior to the proceeding at the address given on notice. Telephone 941-861-4110.

Thomas M. Knight, As Sheriff of
Sarasota County, Florida
By: Sgt. R. Beasley #476
May 16, 23, 30; June 6, 2014

14-02175S

SECOND INSERTION

NOTICE OF ACTION-
CONSTRUCTIVE SERVICE
IN THE CIRCUIT COURT OF THE
TWELFTH JUDICIAL CIRCUIT
IN AND FOR SARASOTA COUNTY,
FLORIDA
GENERAL JURISDICTION
DIVISION

Case No. 2013 CA 000372 NC
Central Mortgage Company
Plaintiff,

vs.
Gyula Tamas Novak; et al.,
Defendants.

TO: Gyula Tamas Novak
Last Known Address: 360 Drake Road,
Venice, FL 34293
Unknown Spouse of Gyula Tamas Novak
Last Known Address: 360 Drake Road,
Venice, FL 34293

YOU ARE HEREBY NOTIFIED
that an action to foreclose a mortgage
on the following property in Sarasota
County, Florida:

CONDOMINIUM UNIT 7-304,
LAS PALMAS OF SARASOTA,
A LUXURY CONDOMINIUM,
TOGETHER WITH AN UN-
DIVIDED INTEREST IN THE
COMMON ELEMENTS, AC-
CORDING TO THE DECLAR-
ATION OF CONDOMINIUM
THEREOF RECORDED IN IN-
STRUMENT #2004247846, AS
AMENDED IN INSTRUMENT
#2004247847, OF THE PUB-
LIC RECORDS OF SARASOTA
COUNTY, FLORIDA.

has been filed against you and you are
required to serve a copy of your written
defenses, if any, to it on Jeremy Apis-
dorf, Esquire, Brock & Scott, PLLC,
the Plaintiff's attorney, whose address
is 1501 N.W. 49th Street, Suite 200, Ft.
Lauderdale, FL 33309, on or before
June 23, 2014, and file the original with
the Clerk of this Court either before ser-
vice on the Plaintiff's attorney or imme-
diately thereafter; otherwise a default
will be entered against you for the relief
demanded in the complaint or petition.

If you are a person with a disability
who needs any accommodation in order
to participate in this proceeding, you are
entitled, at no cost to you, to the pro-
vision of certain assistance. Please con-
tact the Sarasota County Jury Of-
fice, P.O. Box 3079, Sarasota, Florida
34230-3079, (941)861-7400, at least
seven (7) days before your scheduled
court appearance, or immediately upon
receiving this notification if the time
before the scheduled appearance is less
than seven (7) days; if you are hearing
or voice impaired, call 711.

DATED on May 8, 2014.
Karen Rushing
As Clerk of the Court
(SEAL) By C. Brandenburg
As Deputy Clerk

Jeremy Apisdorf, Esquire
Brock & Scott, PLLC
the Plaintiff's Attorney
1501 N.W. 49th St., Suite 200
Ft. Lauderdale, FL 33309
File # 13-F02504
May 23, 30, 2014 14-02225S

SECOND INSERTION

NOTICE OF FORECLOSURE SALE
IN THE CIRCUIT COURT OF THE
TWELFTH JUDICIAL CIRCUIT
IN AND FOR SARASOTA COUNTY,
FLORIDA
CIVIL ACTION

Case No.: 58-2012-CA-002398 NC
DIVISION: A

BANK OF AMERICA, N.A., AS
SUCCESSOR BY MERGER TO
BAC HOME LOANS SERVICING,
LP FKA COUNTRYWIDE HOME
LOANS SERVICING, LP,
Plaintiff, vs.
LINDA E. HUNT, et al,
Defendant(s).

NOTICE IS HEREBY GIVEN pursuant
to a Final Judgment of Mortgage
Foreclosure dated May 12, 2014 and
entered in Case No. 58-2012-CA-
002398 NC of the Circuit Court of the
TWELFTH Judicial Circuit in and for
SARASOTA County, Florida wherein
BANK OF AMERICA, N.A., AS
SUCCESSOR BY MERGER TO BAC
HOME LOANS SERVICING, LP FKA
COUNTRYWIDE HOME LOANS
SERVICING, LP is the Plaintiff and
THE UNKNOWN HEIRS, DEVISEES,
GRANTEES, ASSIGNEES, LIENORS,
CREDITORS, TRUSTEES, OR
OTHER CLAIMANTS CLAIMING
BY, THROUGH, UNDER, OR
AGAINST, LINDA E. HUNT A/K/A
LINDA EDITH HUNT A/K/A
LINDA HUNT, DECEASED;
CHRISTOPHER SCOTT HUNT
A/K/A CHRISTOPHER S. HUNT
AS HEIR OF THE ESTATE OF
LINDA E. HUNT A/K/A LINDA
EDITH HUNT A/K/A LINDA
HUNT, DECEASED; ANY AND ALL
UNKNOWN PARTIES CLAIMING
BY, THROUGH, UNDER, AND
AGAINST THE HEREIN NAMED
INDIVIDUAL DEFENDANT(S)
WHO ARE NOT KNOWN TO BE
DEAD OR ALIVE, WHETHER
SAID UNKNOWN PARTIES MAY
CLAIM AN INTEREST AS SPOUSES,
HEIRS, DEVISEES, GRANTEES,
OR OTHER CLAIMANTS; BANK

SECOND INSERTION

NOTICE OF SALE
IN THE CIRCUIT COURT OF THE
TWELFTH JUDICIAL CIRCUIT
IN AND FOR SARASOTA COUNTY,
FLORIDA
CIVIL DIVISION
Case #: 2009-CA-021628-NC
DIVISION: C

Nationstar Mortgage LLC
Plaintiff, -vs.-
Mark E. Fanning a/k/a Mark
Fanning and Becky D. Fanning,
Husband and Wife; Chase Bank
USA, N.A.; Mortgage Electronic
Registration Systems, Inc. as
Nominee for Irwin Mortgage
Corporation Electronic Data
Systems, LLC
Defendant(s).

NOTICE IS HEREBY GIVEN pursu-
ant to order rescheduling foreclosure
sale or Final Judgment, entered in Civil
Case No. 2009-CA-021628-NC of the
Circuit Court of the 12th Judicial Cir-
cuit in and for Sarasota County, Flori-
da, wherein Nationstar Mortgage LLC,
Plaintiff and Mark E. Fanning a/k/a
Mark Fanning and Becky D. Fanning,
Husband and Wife are defendant(s), I,
Clerk of Court, Karen E. Rushing, will
sell to the highest and best bidder for
cash VIA THE INTERNET AT WWW.
SARASOTA.REALFORECLOSE.COM,
AT 9:00 A.M. on June 18, 2014,
the following described property as set
forth in said Final Judgment, to-wit:

LOT 25, BLOCK 459, 9TH
ADDITION TO PORT CHAR-
LOTTE SUBDIVISION, AC-
CORDING TO THE PLAT
THEREOF, AS RECORDED IN
PLAT BOOK 12, PAGES 21, 21A
THROUGH 21S, PUBLIC RE-
CORDS OF SARASOTA COUN-
TY, FLORIDA.

ANY PERSON CLAIMING AN IN-
TEREST IN THE SURPLUS FROM
THE SALE, IF ANY, OTHER THAN
THE PROPERTY OWNER AS OF
THE DATE OF THE LIS PENDENS
MUST FILE A CLAIM WITHIN 60
DAYS AFTER THE SALE.

If you are a person with a disability
who needs any accommodation in order
to participate in this proceeding, you
are entitled, at no cost to you, to the
provision of certain assistance. Please
contact the Sarasota County Jury Of-
fice, P.O. Box 3079, Sarasota, Florida
34230-3079, (941)861-7400, at least
seven (7) days before your sched-
uled court appearance, or immedi-
ately upon receiving this notification
if the time before the scheduled ap-
pearance is less than seven (7) days;
if you are hearing or voice impaired,
call 711.

Dated on May 14th, 2014.
KAREN E. RUSHING
As Clerk of the Court
(SEAL) By: L. Szymanski
As Deputy Clerk
Submitted By:
ATTORNEY FOR PLAINTIFF:
SHAPIRO, FISHMAN
& GACHÉ, LLP
2424 North Federal Highway,
Suite 360
Boca Raton, Florida 33431
(561) 998-6700
(561) 998-6707
09-161323 FC01 CXE
May 23, 30, 2014 14-02235S

SECOND INSERTION

NOTICE OF ACTION
IN THE CIRCUIT COURT OF THE
TWELFTH JUDICIAL CIRCUIT
IN AND FOR SARASOTA COUNTY,
FLORIDA

Case No.: 2012 CA 003509 NC
WELLS FARGO BANK, NA,
Plaintiff, VS.

UNKNOWN HEIRS,
BENEFICIARIES, DEVISEES,
GRANTEES, ASSIGNEES,
LIENORS, ; et al.,
Defendant(s).

TO: Unknown Heirs, Beneficiaries,
Devisees, Grantees, Assignees, Lienors,
Creditors, Trustees, and all other par-
ties claiming an interest By, Through,
Under or Against The Estate of Carol
S. Wolfson A/K/A Carol S. Lampman,
Deceased
Last Known Residence: Unknown

YOU ARE HEREBY NOTIFIED
that an action to foreclose a mortgage
on the following property in SARASO-
TA County, Florida:

LOT 9, LOMA LINDA PARK,
A SUBDIVISION AS PER
PLAT THEREOF RECORDED
IN PLAT BOOK 5, PAGE 38
OF THE PUBLIC RECORDS
OF SARASOTA COUNTY,
FLORIDA.A.

has been filed against you and you are
required to serve a copy of your written
defenses, if any, to it on ALDRIDGE |
CONNORS, LLP, Plaintiff's attorney,
at 1615 South Congress Avenue, Suite
200, Delray Beach, FL 33445 (Phone
Number: (561) 392-6391), within 30
days of the first date of publication of
this notice, and file the original with
the clerk of this court either before
June 23rd, 2014 on Plaintiff's attorney
or immediately thereafter; otherwise a
default will be entered against you for
the relief demanded in the complaint
or petition.

If you are a person with a disability
who needs any accommodation in order
to participate in this proceeding, you
are entitled, at no cost to you, to the
provision of certain assistance. Please
contact the Sarasota County Jury Of-
fice, P.O. Box 3079, Sarasota,
Florida 34230-3079, (941)861-7400,
at least seven (7) days before your
scheduled court appearance, or immedi-
ately upon receiving this notification
if the time before the scheduled ap-
pearance is less than seven (7) days;
if you are hearing or voice impaired,
call 711.

Dated on May 14th, 2014.
KAREN E. RUSHING
As Clerk of the Court
(SEAL) By: L. Szymanski
As Deputy Clerk

ALDRIDGE | CONNORS, LLP
Plaintiff's Attorney
1615 South Congress Avenue,
Suite 200,
Delray Beach, FL 33445
Phone Number: (561) 392-6391
1113-12181
May 23, 30, 2014 14-02224S

SECOND INSERTION

NOTICE OF SALE
IN THE CIRCUIT COURT OF THE
TWELFTH JUDICIAL CIRCUIT
IN AND FOR SARASOTA COUNTY,
FLORIDA

Case No.: 58 2011 CA 0004642 NC
CITIMORTGAGE, INC.
Plaintiff, v.

RADA MILCEVIC AKA RADA
EDWARDS; CHRISTOPHER
EDWARDS; LARRY PATRICK
EDWARDS; AND ANY AND ALL
UNKNOWN PARTIES CLAIMING
BY, THROUGH, UNDER, AND
AGAINST THE HEREIN NAMED
INDIVIDUAL DEFENDANT(S)
WHO ARE NOT KNOWN TO BE
DEAD OR ALIVE, WHETHER
SAID UNKNOWN PARTIES
MAY CLAIM AN INTEREST AS
SPOUSES, HEIRS, DEVISEES,
GRANTEES, OR OTHER
CLAIMANTS; KENILWORTH
ESTATES HOMEOWNERS
ASSOCIATION, INC.; AND
TENANT
Defendant(s).

NOTICE IS HEREBY GIVEN pursu-
ant to an Order Granting Plaintiff's
Motion to Reset Foreclosure dated
April 21, 2014, entered in Civil Case
No. 58 2011 CA 0004642 NC of the
Circuit Court of the Twelfth Judicial
Circuit in and for Sarasota County,
Florida, wherein the Clerk of the Cir-
cuit Court will sell to the highest bidder
for cash on the 9th day of June, 2014,
at 9:00 a.m. online at the website:
<https://www.sarasota.realforeclose.com>,
relative to the following described
property as set forth in the Final Judg-
ment, to wit:

BEING AT THE SOUTH-
EAST CORNER OF BLOCK 47,
LORD'S ADDITION TO SARA-
SOTA, ACCORDING TO THE
PLAT THEREOF, AS RECORDED
IN PLAT BOOK 1, PAGE 194,
OF THE PUBLIC RECORDS OF
MANATEE COUNTY, FLORIDA,
AND PLAT BOOK A, PAGE 31,
PUBLIC RECORDS OF SARA-
SOTA COUNTY, FLORIDA;
THENCE NORTH ALONG THE

SECOND INSERTION

NOTICE OF FORECLOSURE SALE
IN THE CIRCUIT COURT OF THE
TWELFTH JUDICIAL CIRCUIT, IN
AND FOR SARASOTA COUNTY,
FLORIDA

Case No. 2010 CA 002358 NC
BAC HOME LOANS SERVICING,
LP FKA COUNTRYWIDE HOME
LOANS SERVICING LP,
Plaintiff, vs.

MICHAELA KOKESOVA, et al.
Defendants

NOTICE IS HEREBY GIVEN pursu-
ant to a Final Judgment of Foreclosure
dated May 12, 2014, and entered in
Case No. 2010 CA 002358 NC, of the
Circuit Court of the Twelfth Judicial
Circuit in and for SARASOTA County,
Florida. BANK OF AMERICA, NATION-
AL ASSOCIATION, is Plain-
tiff and MICHAELA KOKESOVA;
DARRIN GRIFFIN A/K/A DARREN
GRIFFIN; MORTGAGE ELECTRONIC
REGISTRATION SYSTEMS INCOR-
PORATED AS NOMINEE FOR
REAL TIME RESOLUTIONS, INC.;
CHARTLEY COURT HOMEOWN-
ERS ASSOCIATION, INC. are defend-
ants. The Clerk of Court will sell to
the highest and best bidder for cash via
the Internet at www.sarasota.realforeclose.com,
at 9:00 a.m., on the 17th day
of June, 2014, the following described
property as set forth in said Final Judg-
ment, to wit:

LOT 20, CHARTLEY COURT,
ACCORDING TO THE PLAT
THEREOF, AS RECORDED
IN PLAT BOOK 31, PAGE 24
AND 24A OF THE PUBLIC RE-
CORDS OF SARASOTA COUN-
TY, FLORIDA.

Any person claiming an interest in the
surplus from the sale, if any, other than
the property owner as of the date of the
Lis Pendens must file a claim within 60
days after the sale.

If you are a person with a disability
who needs any accommodation in order
to participate in this proceeding, you
are entitled, at no cost to you, to the
provision of certain assistance. Please
contact the Sarasota County Jury Of-
fice, P.O. Box 3079, Sarasota, Florida
34230-3079, (941)861-7400, at least
seven (7) days before your sched-
uled court appearance, or immedi-
ately upon receiving this notification
if the time before the scheduled
appearance is less than seven (7)
days; if you are hearing or voice
impaired, call 711.

Mark C. Elia, Esq.
Florida Bar #: 695734
Email: MCElia@vanlawfl.com

VAN NESS LAW FIRM, PLC
1239 E. Newport Center Drive,
Suite 110
Deerfield Beach, Florida 33442
Ph: (954) 571-2031
Fax: (954) 571-2033
PRIMARY EMAIL:
Pleadings@vanlawfl.com
May 23, 30, 2014 14-02237S

SECOND INSERTION

NOTICE OF ACTION
IN THE COUNTY COURT OF THE
TWELFTH JUDICIAL CIRCUIT
IN AND FOR SARASOTA COUNTY,
FLORIDA

Case No.: 2013 CC 005338 SC
CAMELOT COMMUNITIES MHP,
LLC d/b/a Camelot Lakes Mobile
Home Community,
Plaintiff, vs.

GLENN J. SILVERS, JACKIE L.
SILVERS and BANK OF AMERICA,
NATIONAL ASSOCIATION, AS
SUCCESSOR IN INTEREST TO
BARNETT BANK,
Defendants.

TO: Glenn J. Silvers
5893 Waterbury Circle
Sarasota, Florida 34233
Jackie L. Silvers
5893 Waterbury Circle
Sarasota, Florida 34233

YOU ARE NOTIFIED that an action
for money damages and lien fore-
closure upon a mobile home described as
that certain 1981 ELDO mobile home
bearing vehicle identification numbers
06222A and 06222B has been filed
against you, and you are required to
serve a copy of your written defenses,
if any, to Daniel M. Hartzog, Jr., Esq.,
plaintiff's attorney, whose address is
2002 East 4th Avenue, Tampa, Florida
33605, on or before June 23rd 2014,
and file the original with the Clerk
of this Court either before service on
plaintiff's attorney or immediately
thereafter; otherwise a default will be
entered against you for the relief de-
manded in the amended complaint or
petition.

If you are a person with a disability
who needs any accommodation in order
to participate in this proceeding, you
are entitled, at no cost to you, to the
provision of certain assistance. Please
contact the Sarasota County Jury Of-
fice, P.O. Box 3079, Sarasota, Florida
34230-3079, (941)861-7400, at least
seven (7) days before your scheduled
court appearance, or immediately upon
receiving this notification if the time
before the scheduled appearance is less
than seven (7) days; if you are hearing
or voice impaired, call 711.

WITNESS Karen E. Rushing, as
Clerk of the County Court, and the
seal of said Court, at the Courthouse at
Sarasota County, Florida.

Dated: 5-16-14
Karen E. Rushing,
Sarasota County Clerk of Court
2000 Main Street
Sarasota, Florida 34237
(SEAL) By: L. Szymanski
Deputy Clerk

Daniel M. Hartzog, Jr., Esq.
Plaintiff's Attorney
2002 East 4th Avenue
Tampa, Florida 33605
(813) 241-8269
May 23, 30, 2014 14-02229S

SECOND INSERTION

RE-NOTICE OF
FORECLOSURE SALE
IN THE CIRCUIT COURT OF THE
12TH JUDICIAL CIRCUIT, IN
AND FOR SARASOTA COUNTY,
FLORIDA
CIVIL DIVISION:

Case No.: 2009 CA 004859 NC
U.S. BANK NATIONAL
ASSOCIATION, AS TRUSTEE,
SUCCESSOR IN INTEREST TO
WACHOVIA BANK, NATIONAL
ASSOCIATION, AS TRUSTEE FOR
J.P. MORGAN MORTGAGE TRUST
2005-A8
Plaintiff, vs.

ANTHONY J. GUGINO; MARY
E. GUGINO; ANY AND ALL
UNKNOWN PARTIES CLAIMING
BY, THROUGH, UNDER, AND
AGAINST THE HEREIN NAMED
INDIVIDUAL DEFENDANT (S)
WHO ARE NOT KNOWN TO BE
DEAD OR ALIVE, WHETHER
SAID UNKNOWN PARTIES
MAY CLAIM AN INTEREST AS
SPOUSES, HEIRS, DEVISEES,
GRANTEES, OR OTHER
CLAIMANTS; CHASE MORTGAGE
SERVICES, INC. F/K/A CHASE
MANHATTAN MORTGAGE
CORPORATION A DISSOLVED
CORPORATION; THE VENICE
GOLF & COUNTRY CLUB
MASTER ASSOCIATION, INC.;
TENANT #1, TENANT #2, TENANT
#3, AND TENANT #4 the names
being fictitious to account for
parties in possession,
Defendants.

NOTICE IS HEREBY GIVEN pursu-
ant to an Order Resetting Foreclosure
Sale dated the 14th day of March,
2014, and entered in Case No. 2009
CA 004859 NC, of the Circuit Court
of the 12TH Judicial Circuit in and
for Sarasota County, Florida, wherein
U.S. BANK NATIONAL ASSOCIA-
TION, AS TRUSTEE, SUCCESSOR
IN INTEREST TO WACHOVIA
BANK, NATIONAL ASSOCIATION,
AS TRUSTEE FOR J.P. MOR-
GAN MORTGAGE TRUST 2005-
A8 is the Plaintiff and ANTHONY
J. GUGINO; MARY E. GUGINO;
CHASE MORTGAGE SERVICES,
INC. F/K/A CHASE MANHATTAN
MORTGAGE CORPORATION A

DISSOLVED CORPORATION; THE
VENICE GOLF & COUNTRY CLUB
MASTER ASSOCIATION, INC.; and
UNKNOWN TENANT (S) IN POS-
SESSION OF THE SUBJECT PROP-
ERTY are defendants. The Clerk of
this Court shall sell to the highest and
best bidder for cash electronically at
www.sarasota.realforeclose.com
at 9:00 AM on the 12th day of June,
2014, the following described prop-
erty as set forth in said Final Judgment,
to wit:
LOT 478, VENICE GOLF &
COUNTRY CLUB UNIT NO
III-B ACCORDING TO THE
PLAT THEREOF RECORDED
IN PLAT BOOK 35, PAGE 49,
OF THE PUBLIC RECORDS OF
SARASOTA COUNTY FLORI-
DA.
ANY PERSON CLAIMING AN IN-
TEREST IN THE SURPLUS FROM
THE SALE, IF ANY, OTHER THAN
THE PROPERTY OWNER AS OF
THE DATE OF THE LIS PENDENS
MUST FILE A CLAIM WITHIN 60
DAYS AFTER THE SALE.
If you are a person with a dis-
ability who needs any accommoda-
tion in order to participate in this
proceeding, you are entitled, at no
cost to you, to the provision of cer-
tain assistance. Please contact the
Sarasota County Jury Office, P.O. Box
3079, Sarasota, Florida 34230-3079,
(941)861-7400, at least seven (7) days
before your scheduled court appear-
ance, or immediately upon receiving
this notification if the time before
the scheduled appearance is less than
seven (7) days; if you are hearing or
voice impaired, call 711.
Dated this 14 day of May, 2014.
By: Jennifer Nicole Tarquinio
Bar #99192
Choice Legal Group, P.A.
P.O. Box 9908
Fort Lauderdale, FL 33310-0908
Telephone: (954) 453-0365
Facsimile: (954) 771-6052
Toll Free: 1-800-441-2438
DESIGNATED PRIMARY E-MAIL
FOR SERVICE PURSUANT TO FLA
R. JUD. ADMIN 2.516
eservice@legalgroup.com
13-07821
May 23, 30, 2014 14-02227S

SECOND INSERTION

NOTICE OF FORECLOSURE SALE IN THE CIRCUIT COURT OF THE TWELFTH JUDICIAL CIRCUIT IN AND FOR SARASOTA COUNTY GENERAL JURISDICTION DIVISION

CASE NO. 2012 CA 005306 NC OCWEN LOAN SERVICING, LLC, Plaintiff, vs. STUART W. FELDMANN, et al., Defendants.

NOTICE IS HEREBY GIVEN pursuant to a Summary Final Judgment of Foreclosure entered March 24, 2014 in Civil Case No. 2012 CA 005306 NC of the Circuit Court of the TWELFTH Judicial Circuit in and for Sarasota County, Florida, wherein OCWEN LOAN SERVICING, LLC is Plaintiff and STUART W. FELDMANN, TENBUSCH CONSTRUCTION, INC., UNKNOWN TENANT IN POSSESSION #1 N/K/A ANTHONY LEMOS, UNKNOWN TENANT IN POSSESSION #2, UNKNOWN SPOUSE OF STUART W. FELDMANN, are Defendants, the Clerk of Court will sell to the highest and best bidder for cash electronically at www.sarasota.realforeclose.com in accordance with Chapter 45, Florida Statutes on the 12th day of June, 2014 at 09:00 AM on the following described property as set forth in said Summary Final Judgment, to-wit:

Lot 5, Block 1198, 35TH ADDITION TO PORT CHARLOTTE SUBDIVISION, according to the plat thereof recorded in Plat Book 15, Pages 19A through 19C, Inclusive, Public Records of Sarasota County, Florida.

Any person claiming an interest in the surplus from the sale, if any, other than the property owner as of the date of the lis pendens, must file a claim within 60 days after the sale.

If you are a person with a disability who needs any accommodation in order to participate in this proceeding, you are entitled, at no cost to you, to the provision of certain assistance. Please contact the Sarasota County Jury Office, P.O. Box 3079, Sarasota, Florida 34230-3079, (941)861-7400, at least seven (7) days before your scheduled court appearance, or immediately upon receiving this notification if the time before the scheduled appearance is less than seven (7) days; if you are hearing or voice impaired, call 711.

Allyson G Morgado
FL Bar # 91506
Brian Hummel, Esq.
Fla. Bar No.: 46162

McCalla Raymer, LLC
Attorney for Plaintiff
225 E. Robinson St. Suite 660
Orlando, FL 32801
Phone: (407) 674-1850
Fax: (321) 248-0420
Email:
MRService@mcallaraymer.com
2839770
11-05630-5
May 23, 30, 2014 14-02254S

SECOND INSERTION

NOTICE OF FORECLOSURE SALE IN THE CIRCUIT COURT OF THE TWELFTH JUDICIAL CIRCUIT IN AND FOR SARASOTA COUNTY, FLORIDA CIVIL ACTION

CASE NO.: 58 2013 CA 004894 NC DIVISION: A

JAMES B. NUTTER & COMPANY, Plaintiff, vs. THE UNKNOWN HEIRS, DEVISEES, GRANTEES, ASSIGNEES, LIENORS, CREDITORS, TRUSTEES, OR OTHER CLAIMANTS CLAIMING BY, THROUGH, UNDER, OR AGAINST RICHARD A. WINTER A/K/A RICHARD ALAN WINTER, DECEASED, et al, Defendant(s).

NOTICE IS HEREBY GIVEN pursuant to a Final Judgment of Mortgage Foreclosure dated May 12, 2014 and entered in Case No. 58 2013 CA 004894 NC of the Circuit Court of the TWELFTH Judicial Circuit in and for SARASOTA County, Florida wherein JAMES B. NUTTER & COMPANY is the Plaintiff and THE UNKNOWN HEIRS, DEVISEES, GRANTEES, ASSIGNEES, LIENORS, CREDITORS, TRUSTEES, OR OTHER CLAIMANTS CLAIMING BY, THROUGH, UNDER, OR AGAINST RICHARD A. WINTER A/K/A RICHARD ALAN WINTER, DECEASED; DAVID E. DESROCHES, AS AN HEIR OF THE ESTATE OF RICHARD A. WINTER A/K/A RICHARD ALAN WINTER, DECEASED; MARY JOSSELYN WINTER A/K/A MARY J. WINTER, AS AN HEIR OF THE ESTATE OF RICHARD A. WINTER A/K/A RICHARD ALAN WINTER, AS AN HEIR OF THE ESTATE OF RICHARD A. WINTER A/K/A RICHARD ALAN WINTER, DECEASED; ANY AND ALL UNKNOWN PARTIES CLAIMING BY, THROUGH, UNDER, AND AGAINST THE HEREIN NAMED INDIVIDUAL DEFENDANT(S) WHO ARE NOT KNOWN TO BE

SECOND INSERTION

NOTICE OF FORECLOSURE SALE IN THE CIRCUIT COURT OF THE TWELFTH JUDICIAL CIRCUIT IN AND FOR SARASOTA COUNTY, FLORIDA CIVIL ACTION

CASE NO.: 58-2013-CA-008221 NC DIVISION: C

U.S. BANK NATIONAL ASSOCIATION, AS TRUSTEE, FOR AMERICAN GENERAL MORTGAGE LOAN TRUST 2010-1 AMERICAN GENERAL MORTGAGE PASS-THROUGH CERTIFICATES, SERIES 2010-1, Plaintiff, vs. JOHN D. GILLES, et al, Defendant(s).

NOTICE IS HEREBY GIVEN pursuant to a Final Judgment of Mortgage Foreclosure dated May 12, 2014 and entered in Case No. 58-2013-CA-008221 NC of the Circuit Court of the TWELFTH Judicial Circuit in and for SARASOTA County, Florida wherein U.S. BANK NATIONAL ASSOCIATION, AS TRUSTEE, FOR AMERICAN GENERAL MORTGAGE LOAN TRUST 2010-1 AMERICAN GENERAL MORTGAGE PASS-THROUGH CERTIFICATES, SERIES 2010-1 is the Plaintiff and JOHN D. GILLES; TAMMY A. GILLES; are the Defendants. The Clerk will sell to the highest and best bidder for cash at WWW.SARASOTA.REALFORECLOSE.COM at 9:00AM, on the 9th day of September, 2014, the following described property as set forth in said Final Judgment:

LOT 115 OF TOWN & COUNTRY ESTATES, UNIT NO. 2, ACCORDING TO THE PLAT THEREOF AS RECORDED IN PLAT BOOK 10, PAGE 29, OF THE PUBLIC RECORDS OF SARASOTA COUNTY, FLORIDA.

A/K/A 3556 AUSTIN STREET, SARASOTA, FL 34231

Any person claiming an interest in the surplus from the sale, if any, other than the property owner as of the date of the Lis Pendens must file a claim within sixty (60) days after the sale.

If you are a person with a disability who needs any accommodation in order to participate in this proceeding, you are entitled, at no cost to you, to the provision of certain assistance. Please contact the Sarasota County Jury Office, P.O. Box 3079, Sarasota, Florida 34230-3079, (941)861-7400, at least seven (7) days before your scheduled court appearance, or immediately upon receiving this notification if the time before the scheduled appearance is less than seven (7) days; if you are hearing or voice impaired, call 711.

By: Lisa M. Lewis
Florida Bar No. 0086718
Ronald R Wolfe & Associates, P.L.
P.O. Box 25018
Tampa, Florida 33622-5018
(813) 251-4766
(813) 251-1541 Fax
F12019751
May 23, 30, 2014 14-02261S

SECOND INSERTION

DEAD OR ALIVE, WHETHER SAID UNKNOWN PARTIES MAY CLAIM AN INTEREST AS SPOUSES, HEIRS, DEVISEES, GRANTEES, OR OTHER CLAIMANTS; UNITED STATES OF AMERICA ON BEHALF OF U.S. DEPARTMENT OF HOUSING AND URBAN DEVELOPMENT; are the Defendants. The Clerk will sell to the highest and best bidder for cash at WWW.SARASOTA.REALFORECLOSE.COM at 9:00AM, on the 16th day of June, 2014, the following described property as set forth in said Final Judgment:

LOT 9, BLOCK 18, 13TH ADDITION TO PORT CHARLOTTE SUBDIVISION, ACCORDING TO THE PLAT RECORDED IN PLAT BOOK 13, PAGES 12, 12A THROUGH 12F, OF THE PUBLIC RECORDS OF SARASOTA COUNTY, FLORIDA.

A/K/A 6408 PAN AMERICAN BOULEVARD, NORTH PORT, FL 34287

Any person claiming an interest in the surplus from the sale, if any, other than the property owner as of the date of the Lis Pendens must file a claim within sixty (60) days after the sale.

If you are a person with a disability who needs any accommodation in order to participate in this proceeding, you are entitled, at no cost to you, to the provision of certain assistance. Please contact the Sarasota County Jury Office, P.O. Box 3079, Sarasota, Florida 34230-3079, (941)861-7400, at least seven (7) days before your scheduled court appearance, or immediately upon receiving this notification if the time before the scheduled appearance is less than seven (7) days; if you are hearing or voice impaired, call 711.

By: J. Bennett Kitterman
Florida Bar No. 98636
Ronald R Wolfe & Associates, P.L.
P.O. Box 25018
Tampa, Florida 33622-5018
(813) 251-4766
(813) 251-1541 Fax
F13006929
May 23, 30, 2014 14-02259S

SECOND INSERTION

NOTICE OF FORECLOSURE SALE IN THE CIRCUIT COURT OF THE 12TH JUDICIAL CIRCUIT, IN AND FOR SARASOTA COUNTY, FLORIDA CIVIL ACTION

CASE NO.: 2013 CA 001844 NC

FEDERAL NATIONAL MORTGAGE ASSOCIATION, Plaintiff, vs. MICHAEL A. HITZMAN; SHARON C. HILBERS; CARL E. HILBERS, JR.; KATE F. HITZMAN; UNKNOWN TENANT IN POSSESSION OF THE SUBJECT PROPERTY, Defendants.

NOTICE IS HEREBY GIVEN pursuant to Final Judgment of Foreclosure dated the 5th day of May, 2014, and entered in Case No. 2013 CA 001844 NC, of the Circuit Court of the 12TH Judicial Circuit in and for Sarasota County, Florida, wherein FEDERAL NATIONAL MORTGAGE ASSOCIATION is the Plaintiff and SHARON C. HILBERS; CARL E. HILBERS, JR.; KATE F. HITZMAN and UNKNOWN TENANT (S) IN POSSESSION OF THE SUBJECT PROPERTY are defendants. The Clerk of this Court shall sell to the highest and best bidder for cash electronically at www.sarasota.realforeclose.com at 9:00 AM on the 6th day of June, 2014, the following described property as set forth in said Final Judgment, to-wit:

LOT 3, LAKEVIEW TERRACE, ACCORDING TO THE PLAT THEREOF, AS RECORDED IN PLAT BOOK 10, PAGE 30, OF THE PUBLIC RECORDS OF SARASOTA COUNTY, FLORIDA.

ANY PERSON CLAIMING AN INTEREST IN THE SURPLUS FROM THE SALE, IF ANY, OTHER THAN THE PROPERTY OWNER AS OF THE DATE OF THE LIS PENDENS MUST FILE A CLAIM WITHIN 60 DAYS AFTER THE SALE.

If you are a person with a disability who needs any accommodation in order to participate in this proceeding, you are entitled, at no cost to you, to the provision of certain assistance. Please contact the Sarasota County Jury Office, P.O. Box 3079, Sarasota, Florida 34230-3079, (941)861-7400, at least seven (7) days before your scheduled court appearance, or immediately upon receiving this notification if the time before the scheduled appearance is less than seven (7) days; if you are hearing or voice impaired, call 711.

Dated this 15th day of May, 2014.
By: Jennifer Nicole Tarquinio
Bar #99192

Choice Legal Group, P.A.
P.O. Box 9908
Fort Lauderdale, FL 33310-9908
Telephone: (954) 453-0365
Facsimile: (954) 771-6052
Toll Free: 1-800-441-2438
DESIGNATED PRIMARY E-MAIL FOR SERVICE PURSUANT TO FLA R. JUD. ADMIN 2.516
eservice@clegalgroup.com
11-15536
May 23, 30, 2014 14-02252S

SECOND INSERTION

NOTICE OF RESCHEDULED FORECLOSURE SALE IN THE CIRCUIT COURT OF THE TWELFTH JUDICIAL CIRCUIT IN AND FOR SARASOTA COUNTY, FLORIDA CIVIL ACTION

CASE NO.: 2009-CA-009236-NC DIVISION: A

WELLS FARGO BANK, NATIONAL ASSOCIATION AS TRUSTEE FOR THE CERTIFICATEHOLDERS OF STRUCTURED ASSET MORTGAGE INVESTMENTS II INC., GREENPOINT MTA TRUST 2006-AR3, MORTGAGE PASS-THROUGH CERTIFICATES, SERIES 2006-AR3, Plaintiff, vs. ANTHONY D'ATRIA, et al, Defendant(s).

NOTICE IS HEREBY GIVEN pursuant to an Order Rescheduling Foreclosure Sale dated May 5, 2014 and entered in Case NO. 2009-CA-009236-NC of the Circuit Court of the TWELFTH Judicial Circuit in and for SARASOTA County, Florida wherein WELLS FARGO BANK, NATIONAL ASSOCIATION AS TRUSTEE FOR THE CERTIFICATEHOLDERS OF STRUCTURED ASSET MORTGAGE INVESTMENTS II INC., GREENPOINT MTA TRUST 2006-AR3, MORTGAGE PASS-THROUGH CERTIFICATES, SERIES 2006-AR3, is the Plaintiff and ANTHONY D'ATRIA; MORTGAGE ELECTRONIC REGISTRATION SYSTEMS INCORPORATED AS NOMINEE FOR BAC HOME LOANS SERVICING, LP; RENAISSANCE I ASSOCIATION, INC.; ROSEMARY PLACE MASTER ASSOCIATION, INC. F/K/A THE RENAISSANCE OF SARASOTA MASTER ASSOCIATION, INC.; TENANT #1 N/K/A MICHAEL HUGEN are the Defendants. The Clerk will sell to the highest and best bidder for cash at WWW.SARASOTA.REALFORECLOSE.COM at 9:00AM, on 06/18/2014, the following described property as set forth in said Final Judgment:

UNIT NO. 1402,

SECOND INSERTION

NOTICE OF FORECLOSURE SALE IN THE CIRCUIT COURT OF THE 12TH JUDICIAL CIRCUIT, IN AND FOR SARASOTA COUNTY, FLORIDA

CASE NO. 2009 CA 020477 NC CIRCUIT CIVIL A

U.S. BANK NATIONAL ASSOCIATION AS TRUSTEE, SUCCESSOR-IN-INTEREST TO WACHOVIA BANK, NATIONAL ASSOCIATION AS TRUSTEE FOR GSA HOME EQUITY Plaintiff, vs. MICHAEL T. BOWERMAN, SUSAN M. BOWERMAN, ET AL, Defendant(s).

NOTICE IS HEREBY GIVEN pursuant to a Final Judgment of Foreclosure dated MAY 8, 2014 and entered in Case No. 2009 CA 020477 NC of the Circuit Court of the Twelfth Judicial Circuit in and for Sarasota County, Florida wherein U.S. BANK NATIONAL ASSOCIATION AS TRUSTEE, SUCCESSOR-IN-INTEREST TO WACHOVIA BANK, NATIONAL ASSOCIATION AS TRUSTEE FOR GSA HOME EQUITY is the Plaintiff and, MICHAEL T. BOWERMAN and SUSAN M. BOWERMAN are the Defendant(s). The Clerk of the Circuit Court shall sell the property at public sale on June 23, 2014, to the highest bidder for cash, in accordance with section 45.031, Florida Statutes, by electronic sale beginning at 9:00 am, on the prescribed date at https://SARASOTA.REALFORECLOSE.COM the following described property as set forth in said Final Judgment to-wit:

LOT 80, SECLUDED OAKS, as per plat thereof recorded in plat Book 42, Page 25 of the Public Records of Sarasota County, Florida.

PARCEL ID # 00258-14-0015 ADDRESS: 6251 YELLOW WOOD PLACE, SARASOTA FL 34241

Any person claiming an interest in the surplus from the sale, if any, other than the property owner as of the date of the lis pendens must file a claim within 60 days after the sale.

If you are a person with a disability who needs any accommodation in order to participate in this proceeding, you are entitled, at no cost to you, to the provision of certain assistance. Please contact the Sarasota County Jury Office, P.O. Box 3079, Sarasota, Florida 34230-3079, (941)861-7400, at least seven (7) days before your scheduled court appearance, or immediately upon receiving this notification if the time before the scheduled appearance is less than seven (7) days; if you are hearing or voice impaired, call 711.

Dated this 15th day of MAY, 2014.
By: /S/Mark F. Booth
Mark F. Booth, Esq.
Fla. Bar No.: 829005

Attorney for Plaintiff:
ROGERS, MORRIS & ZIEGLER LLP
1401 East Broward Blvd., Suite 300
Ft. Lauderdale, FL 33301
Telephone: (954) 462-1431
Email: mfbooth@rmzlaw.com
Secondary Email: susan@rmzlaw.com
May 23, 30, 2014 14-02256S

SECOND INSERTION

RENAISSANCE I, A CONDOMINIUM ACCORDING TO THE DECLARATION OF CONDOMINIUM RECORDED IN OFFICIAL RECORDS INSTRUMENT NO. 2001000167 AND AMENDMENTS THERETO, AND AS PER PLAT THEREOF RECORDED IN CONDOMINIUM BOOK 34, PAGES 39 THRU 39HH, AND AMENDMENTS THERETO, OF THE PUBLIC RECORDS OF SARASOTA COUNTY, FLORIDA TOGETHER WITH AN UNDIVIDED INTEREST IN THE COMMON ELEMENTS APPURTENANT THERETO AS SET FORTH IN SAID DECLARATION

A/K/A 750 N TAMIAMI TRAILUNIT 1402, SARASOTA, FL 34236

Any person claiming an interest in the surplus from the sale, if any, other than the property owner as of the date of the Lis Pendens must file a claim within sixty (60) days after the sale.

If you are a person with a disability who needs any accommodation in order to participate in this proceeding, you are entitled, at no cost to you, to the provision of certain assistance. Please contact the Sarasota County Jury Office, P.O. Box 3079, Sarasota, Florida 34230-3079, (941)861-7400, at least seven (7) days before your scheduled court appearance, or immediately upon receiving this notification if the time before the scheduled appearance is less than seven (7) days; if you are hearing or voice impaired, call 711.

By: Victoria S. Jones
Florida Bar No. 52252
Ronald R Wolfe & Associates, P.L.
P.O. Box 25018
Tampa, Florida 33622-5018
(813) 251-4766
(813) 251-1541 Fax
F09058757
May 23, 30, 2014 14-02264S

SECOND INSERTION

NOTICE OF FORECLOSURE SALE IN THE CIRCUIT COURT OF THE TWELFTH JUDICIAL CIRCUIT, IN AND FOR SARASOTA COUNTY, FLORIDA

CASE NO. 2010 CA 012327 NC

SUNTRUST MORTGAGE, INC, Plaintiff, vs. ELLEN S. GOLDBERG, et al, Defendants

NOTICE IS HEREBY GIVEN pursuant to a Final Judgment of Foreclosure dated March 17, 2014, and entered in Case No. 2010 CA 012327 NC, of the Circuit Court of the Twelfth Judicial Circuit in and for SARASOTA County, Florida. U.S. BANK TRUST, N.A., AS TRUSTEE FOR VOLT NPL IX ASSET HOLDINGS TRUST, is Plaintiff and ELLEN S. GOLDBERG; SUNTRUST BANK; ELLEN S. GOLDBERG, AS TRUSTEE OF THE MARK L. TISHMAN REVOCABLE LIVING TRUST DATED 11/7/1996; SHIRLEY J. GOLDBERG TRUSTEE OF THE SHIRLEY J. GOLDBERG LIVING TRUST DATED 11/7/1996; MARK L. TISHMAN; MARK L. TISHMAN, AS TRUSTEE OF THE MARK L. TISHMAN REVOCABLE LIVING TRUST DATED 11/7/1996; UNKNOWN HEIRS, BENEFICIARIES, DEVISEES, ASSIGNEES, LIENORS, CREDITORS, TRUSTEES AND ALL OTHERS WHO MAY CLAIM AN INTEREST IN THE MARK L. TISHMAN REVOCABLE LIVING TRUST DATED 11/7/1996, are defendants. The Clerk of Court will sell to the highest and best bidder for cash via the Internet at www.sarasota.realforeclose.com, at 9:00 a.m., on the 13th day of June, 2014, the following described property as set forth in said Final Judgment, to-wit:

LOT 13, KENTWOOD ESTATES AS PER PLAT THEREOF RECORDED IN PLAT BOOK 18, PAGE 32 OF THE PUBLIC RECORDS OF SARASOTA COUNTY, FLORIDA

Any person claiming an interest in the surplus from the sale, if any, other than the property owner as of the date of the Lis Pendens must file a claim within 60 days after the sale.

If you are a person with a disability who needs any accommodation in order to participate in this proceeding, you are entitled, at no cost to you, to the provision of certain assistance. Please contact the Sarasota County Jury Office, P.O. Box 3079, Sarasota, Florida 34230-3079, (941)861-7400, at least seven (7) days before your scheduled court appearance, or immediately upon receiving this notification if the time before the scheduled appearance is less than seven (7) days; if you are hearing or voice impaired, call 711.

By: Mark C. Elia, Esq.
Florida Bar #: 695734
Email: MCElia@vanlawfl.com
VAN NESS LAW FIRM, PLC
1239 E. Newport Center Drive,
Suite 110
Deerfield Beach, Florida 33442
Ph: (954) 571-2031
Fax: (954) 571-2033
PRIMARY EMAIL:
Pleadings@vanlawfl.com
VF7327-12/ee
May 23, 30, 2014 14-02238S

SECOND INSERTION

NOTICE OF FORECLOSURE SALE IN THE CIRCUIT COURT OF THE TWELFTH JUDICIAL CIRCUIT IN AND FOR SARASOTA COUNTY, FLORIDA CIVIL ACTION

CASE NO.: 2010-CA-007890-NC DIVISION: A

BAC HOME LOANS SERVICING, LP FKA COUNTRYWIDE HOME LOANS SERVICING LP, Plaintiff, vs. JACINDA J. GUNDZIK A/K/A JACINDA GUNDZIK, et al, Defendant(s).

NOTICE IS HEREBY GIVEN pursuant to a Final Judgment of Mortgage Foreclosure dated May 12, 2014 and entered in Case No. 2010-CA-007890-NC of the Circuit Court of the TWELFTH Judicial Circuit in and for SARASOTA County, Florida wherein GREEN TREE SERVICING LLC, 1 Plaintiff name has changed pursuant to order previously entered, is the Plaintiff and JACINDA J. GUNDZIK A/K/A JACINDA GUNDZIK; DARYLL GUNDZIK; ANY AND ALL UNKNOWN PARTIES CLAIMING BY, THROUGH, UNDER, AND AGAINST THE HEREIN NAMED INDIVIDUAL DEFENDANT(S) WHO ARE NOT KNOWN TO BE DEAD OR ALIVE, WHETHER SAID UNKNOWN PARTIES MAY CLAIM AN INTEREST AS SPOUSE, HEIRS, DEVISEES, GRANTEES, OR OTHER CLAIMANTS; CITIBANK, NATIONAL ASSOCIATION SUCCESSOR BY MERGER TO CITIBANK, FSB; are the Defendants. The Clerk will sell to the highest and best bidder for cash at WWW.SARASOTA.REALFORECLOSE.COM at 9:00AM, on the

SECOND INSERTION

NOTICE OF FORECLOSURE SALE IN THE CIRCUIT COURT OF THE TWELFTH JUDICIAL CIRCUIT IN AND FOR SARASOTA COUNTY, FLORIDA CIVIL ACTION

CASE NO.: 58-2013-CA-008132 NC DIVISION: A

NORTHERN TRUST, N.A., Plaintiff, vs. GARY E. PROBST A/K/A GARY PROBST, et al, Defendant(s).

NOTICE IS HEREBY GIVEN pursuant to a Final Judgment of Mortgage Foreclosure dated May 12, 2014 and entered in Case No. 58-2013-CA-008132 NC of the Circuit Court of the TWELFTH Judicial Circuit in and for SARASOTA County, Florida wherein NORTHERN TRUST, N.A. is the Plaintiff and GARY E. PROBST A/K/A GARY PROBST; THE UNKNOWN SPOUSE OF GARY E. PROBST A/K/A GARY PROBST; ANY AND ALL UNKNOWN PARTIES CLAIMING BY, THROUGH, UNDER, AND AGAINST THE HEREIN NAMED INDIVIDUAL DEFENDANT(S) WHO ARE NOT KNOWN TO BE DEAD OR ALIVE, WHETHER SAID UNKNOWN PARTIES MAY CLAIM AN INTEREST AS SPOUSES, HEIRS, DEVISEES, GRANTEES, OR OTHER CLAIMANTS; TENANT #1 N/K/A TIFFANY HARRIS, and TENANT #2 N/K/A TOM HARRIS are the Defendants. The Clerk will sell to the highest and best bidder for cash at WWW.SARASOTA.REALFORECLOSE.COM at 9:00AM, on the 18th day of June, 2014, the following described property as set forth in said Final Judgment:

LOT 19, CHANNEL ACRES, ACCORDING TO THE PLAT THEREOF RECORDED IN PLAT BOOK 10, PAGE 51, OF THE PUBLIC RECORDS OF SARASOTA A COUNTY, FLORIDA.

SUBJECT TO RESTRICTIONS, RESERVATIONS AND EASEMENTS OF RECORD, IF ANY.

Any person claiming an interest in the surplus from the sale, if any, other than the property owner as of the date of the Lis Pendens must file a claim within sixty (60) days after the sale.

If you are a person with a disability who needs any accommodation in order to participate in this proceeding, you are entitled, at no cost to you, to the provision of certain assistance. Please contact the Sarasota County Jury Office, P.O. Box 3079, Sarasota, Florida 34230-3079, (941)861-7400, at least seven (7) days before your scheduled court appearance, or immediately upon receiving this notification if the time before the scheduled appearance is less than seven (7) days; if you are hearing or voice impaired, call 711.

By: Victoria S. Jones
Florida Bar No. 52252
Ronald R Wolfe & Associates, P.L.
P.O. Box 25018
Tampa, Florida 33622-5018
(813) 251-4766
(813) 251-1541 Fax
F13015133
May 23, 30, 2014 14-02242S

SECOND INSERTION

17th day of June, 2014, the following described property as set forth in said Final Judgment:

LOT 38, BLOCK 2581, FIFTY-FIRST ADDITION TO PORT CHARLOTTE SUBDIVISION, A SUBDIVISION ACCORDING TO THE PLAT THEREOF AS RECORDED IN PLAT BOOK 21, PAGE 8, SA THROUGH 8GG, OF THE PUBLIC RECORDS OF SARASOTA COUNTY, FLORIDA.

A/K/A 2042 LOVOY COURT, NORTH PORT, FL 34288

Any person claiming an interest in the surplus from the sale, if any, other than the property owner as of the date of the Lis Pendens must file a claim within sixty (60) days after the sale.

If you are a person with a disability who needs any accommodation in order to participate in this proceeding, you are entitled, at no cost to you, to the provision of certain assistance. Please contact the Sarasota County Jury Office, P.O. Box 3079, Sarasota, Florida 34230-3079, (941)861-7400, at least seven (7) days before your scheduled court appearance, or immediately upon receiving this notification if the time before the scheduled appearance is less than seven (7) days; if you are hearing or voice impaired, call 711.

By: J. Bennett Kitterman
Florida Bar No. 98636
Ronald R Wolfe & Associates, P.L.
P.O. Box 25018
Tampa, Florida 33622-5018
(813) 251-4766
(813) 251-1541 Fax
F10044074
May 23, 30, 2014 14-02258S

HOW TO PUBLISH YOUR LEGAL NOTICE IN THE Business Observer

FOR MORE INFORMATION, CALL:
(813) 221-9505 Hillsborough, Pasco
(727) 447-7784 Pinellas
(941) 906-9386 Manatee, Sarasota, Lee
(239) 263-0122 Collier
(407) 654-5500 Orange
(941) 248-4900 Charlotte
Or e-mail: legal@businessobserverfl.com

SECOND INSERTION

NOTICE OF FORECLOSURE SALE IN THE CIRCUIT COURT OF THE TWELFTH JUDICIAL CIRCUIT IN AND FOR SARASOTA COUNTY, FLORIDA
CIVIL ACTION
CASE NO.: 2014 CA 000631 NC
DIVISION: C

WELLS FARGO BANK, NA, Plaintiff, vs. PATRICIA A. ROSS, et al, Defendant(s). NOTICE IS HEREBY GIVEN pursuant to a Final Judgment of Mortgage Foreclosure dated May 12, 2014 and entered in Case No. 2014 CA 000631 NC of the Circuit Court of the TWELFTH JUDICIAL CIRCUIT in and for SARASOTA County, Florida wherein WELLS FARGO BANK, NA is the Plaintiff and PATRICIA A. ROSS, et al, are the Defendants. The Clerk will sell to the highest and best bidder for cash at WWW.SARASOTA.REALFORECLOSE.COM at 9:00AM, on the 18th day of June, 2014, the following described property as set forth in said Final Judgment:

LOT 14, BLOCK 221, VENICE, NORTH EDGEWOOD SECTION, ACCORDING TO THE PLAT THEREOF RECORDED IN PLAT BOOK 3, PAGE 8, OF THE PUBLIC RECORDS OF SARASOTA COUNTY, FLORIDA.

A/K/A 1004 LAUREL AVENUE, VENICE, FL 34285-7818
Any person claiming an interest in the surplus from the sale, if any, other than the property owner as of the date of the Lis Pendens must file a claim within sixty (60) days after the sale.

If you are a person with a disability who needs any accommodation in order to participate in this proceeding, you are entitled, at no cost to you, to the provision of certain assistance. Please contact the Sarasota County Jury Office, P.O. Box 3079, Sarasota, Florida 34230-3079, (941)861-7400, at least seven (7) days before your scheduled court appearance, or immediately upon receiving this notification if the time before the scheduled appearance is less than seven (7) days; if you are hearing or voice impaired, call 711.

Karen E. Rushing
By: Frances Grace Cooper, Esquire
Attorney for Plaintiff
Edward B. Pritchard
(813) 229-0900 x1309
Kass Shuler, P.A.
P.O. Box 800
Tampa, FL 33601-0800
ForeclosureService@kasslaw.com
200850/1119414/
May 23, 30, 2014 14-02248S

SECOND INSERTION

NOTICE OF SALE IN THE CIRCUIT CIVIL COURT OF THE TWELFTH JUDICIAL CIRCUIT OF FLORIDA, IN AND FOR SARASOTA COUNTY CIVIL DIVISION
Case No. 58-2012-CA-009806 NC
Division C

JPMORGAN CHASE BANK, NATIONAL ASSOCIATION Plaintiff, vs. JEFFREY P. INTERBITZEN A/K/A JEFFREY INTERBITZEN AND UNKNOWN TENANTS/OWNERS, Defendants. Notice is hereby given, pursuant to Final Judgment of Foreclosure for Plaintiff entered in this cause on July 22, 2013, in the Circuit Court of Sarasota County, Florida, The Clerk of the Court will sell the property situated in Sarasota County, Florida described as:

LOT 19, BLOCK 3 OF CENTRAL PARK SUBDIVISION, NO.1, ACCORDING TO THE PLAT THEREOF AS RECORDED IN PLAT BOOK 1, PAGE(S) 1, OF THE PUBLIC RECORDS OF SARASOTA COUNTY, FLORIDA.

and commonly known as: 1709 4TH ST, SARASOTA, FL 34236; including the building, appurtenances, and fixtures located therein, at public sale, to the highest and best bidder, for cash, Sales are held online at: <https://www.sarasota.realforeclose.com>, on June 11, 2014 at 9:00 A.M..

Any persons claiming an interest in the surplus from the sale, if any, other than the property owner as of the date of the lis pendens must file a claim within 60 days after the sale.

If you are a person with a disability who needs any accommodation in order to participate in this proceeding, you are entitled, at no cost to you, to the provision of certain assistance. Please contact the Sarasota County Jury Office, P.O. Box 3079, Sarasota, Florida 34230-3079, (941)861-7400, at least seven (7) days before your scheduled court appearance, or immediately upon receiving this notification if the time before the scheduled appearance is less than seven (7) days; if you are hearing or voice impaired, call 711.

Karen E. Rushing
By: Frances Grace Cooper, Esquire
Attorney for Plaintiff
Edward B. Pritchard
(813) 229-0900 x1309
Kass Shuler, P.A.
P.O. Box 800
Tampa, FL 33601-0800
ForeclosureService@kasslaw.com
200850/1119414/
May 23, 30, 2014 14-02253S

SECOND INSERTION

NOTICE OF FORECLOSURE SALE IN THE CIRCUIT COURT OF THE TWELFTH JUDICIAL CIRCUIT IN AND FOR SARASOTA COUNTY, FLORIDA
CIVIL ACTION
CASE NO.: 58-2013-CA-006496-NC
DIVISION: C

WELLS FARGO BANK, NA, Plaintiff, vs. MIKE KRSTEC, et al, Defendant(s). NOTICE IS HEREBY GIVEN pursuant to a Final Judgment of Mortgage Foreclosure dated May 12, 2014 and entered in Case No. 58-2013-CA-006496-NC of the Circuit Court of the TWELFTH JUDICIAL CIRCUIT in and for SARASOTA County, Florida wherein WELLS FARGO BANK, NA is the Plaintiff and MIKE KRSTEC; SUSAN R KRSTEC; TENANT #1 N/K/A MICHAEL KRSTEC are the Defendants. The Clerk will sell to the highest and best bidder for cash at WWW.SARASOTA.REALFORECLOSE.COM at 9:00AM, on the 16th day of June, 2014, the following described property as set forth in said Final Judgment:

LOT 9, BLOCK 1279 OF 26TH ADDITION TO PORT CHARLOTTE SUBDIVISION, A SUBDIVISION ACCORDING TO THE PLAT THEREOF, AS RECORDED IN PLAT BOOK 15, PAGE 3, OF THE PUBLIC RECORDS OF SARASOTA COUNTY, FLORIDA.

A/K/A 3262 ROGUE STREET, NORTH PORT, FL 34291
Any person claiming an interest in the surplus from the sale, if any, other than the property owner as of the date of the Lis Pendens must file a claim within sixty (60) days after the sale.

If you are a person with a disability who needs any accommodation in order to participate in this proceeding, you are entitled, at no cost to you, to the provision of certain assistance. Please contact the Sarasota County Jury Office, P.O. Box 3079, Sarasota, Florida 34230-3079, (941)861-7400, at least seven (7) days before your scheduled court appearance, or immediately upon receiving this notification if the time before the scheduled appearance is less than seven (7) days; if you are hearing or voice impaired, call 711.

Amy Recla
By: Amy Recla
Florida Bar No. 102811
Ronald R Wolfe & Associates, P.L.
P.O. Box 25018
Tampa, Florida 33622-5018
(813) 251-4766
(813) 251-1541 Fax
F13012074
May 23, 30, 2014 14-02246S

SECOND INSERTION

NOTICE OF FORECLOSURE SALE IN THE CIRCUIT COURT OF THE TWELFTH JUDICIAL CIRCUIT IN AND FOR SARASOTA COUNTY, FLORIDA
CIVIL ACTION
CASE NO.: 58-2013-CA-006916 NC
DIVISION: C

WELLS FARGO BANK, N.A., Plaintiff, vs. REGAN E. PATON A/K/A REGAN PATON, et al, Defendant(s). NOTICE IS HEREBY GIVEN pursuant to a Final Judgment of Mortgage Foreclosure dated May 12, 2014 and entered in Case No. 58-2013-CA-006916 NC of the Circuit Court of the TWELFTH JUDICIAL CIRCUIT in and for SARASOTA County, Florida wherein WELLS FARGO BANK, N.A. is the Plaintiff and REGAN E. PATON A/K/A REGAN PATON; BRANCH BANKING AND TRUST COMPANY; PINE MEADOW ASSOCIATION, INC.; are the Defendants. The Clerk will sell to the highest and best bidder for cash at WWW.SARASOTA.REALFORECLOSE.COM at 9:00AM, on the 17th day of June, 2014, the following described property as set forth in said Final Judgment:

LOT 15, PINE MEADOW SUBDIVISION, ACCORDING TO THE MAP OR PLAT THEREOF AS RECORDED IN PLAT BOOK 24, PAGE 17, OF THE PUBLIC RECORDS OF SARASOTA COUNTY, FLORIDA.

A/K/A 4103 PINE MEADOW TERRACE, SARASOTA, FL 34233-3640
Any person claiming an interest in the surplus from the sale, if any, other than the property owner as of the date of the Lis Pendens must file a claim within sixty (60) days after the sale.

If you are a person with a disability who needs any accommodation in order to participate in this proceeding, you are entitled, at no cost to you, to the provision of certain assistance. Please contact the Sarasota County Jury Office, P.O. Box 3079, Sarasota, Florida 34230-3079, (941)861-7400, at least seven (7) days before your scheduled court appearance, or immediately upon receiving this notification if the time before the scheduled appearance is less than seven (7) days; if you are hearing or voice impaired, call 711.

Amy Recla
By: Amy Recla
Florida Bar No. 102811
Ronald R Wolfe & Associates, P.L.
P.O. Box 25018
Tampa, Florida 33622-5018
(813) 251-4766
(813) 251-1541 Fax
F13013166
May 23, 30, 2014 14-02247S

SECOND INSERTION

NOTICE OF FORECLOSURE SALE IN THE CIRCUIT COURT OF THE TWELFTH JUDICIAL CIRCUIT IN AND FOR SARASOTA COUNTY, FLORIDA
CIVIL ACTION
CASE NO.: 58-2013-CA-006355-NC
DIVISION: A

WELLS FARGO BANK, NA, Plaintiff, vs. MICHAEL S DART, et al, Defendant(s). NOTICE IS HEREBY GIVEN pursuant to a Final Judgment of Mortgage Foreclosure dated May 12, 2014 and entered in Case No. 58-2013-CA-006355-NC of the Circuit Court of the TWELFTH JUDICIAL CIRCUIT in and for SARASOTA County, Florida wherein WELLS FARGO BANK, NA is the Plaintiff and MICHAEL S DART; JENNIFER A DART; BANK OF AMERICA, NA; TENANT #1 N/K/A SCOTT A. MARTIN, and TENANT #2 N/K/A HEATHER ASHTON are the Defendants. The Clerk will sell to the highest and best bidder for cash at WWW.SARASOTA.REALFORECLOSE.COM at 9:00AM, on the 17th day of June, 2014, the following described property as set forth in said Final Judgment:

LOT 13, BLOCK 137, 8TH ADDITION TO PORT CHARLOTTE SUBDIVISION, ACCORDING TO THE PLAT THEREOF RECORDED IN PLAT BOOK 12, PAGE 20, OF THE PUBLIC RECORDS OF SARASOTA COUNTY, FLORIDA.

A/K/A 2228 BONANZA LANE, NORTH PORT, FL 34286-1109
Any person claiming an interest in the surplus from the sale, if any, other than the property owner as of the date of the Lis Pendens must file a claim within sixty (60) days after the sale.

If you are a person with a disability who needs any accommodation in order to participate in this proceeding, you are entitled, at no cost to you, to the provision of certain assistance. Please contact the Sarasota County Jury Office, P.O. Box 3079, Sarasota, Florida 34230-3079, (941)861-7400, at least seven (7) days before your scheduled court appearance, or immediately upon receiving this notification if the time before the scheduled appearance is less than seven (7) days; if you are hearing or voice impaired, call 711.

Amy Recla
By: Amy Recla
Florida Bar No. 102811
Ronald R Wolfe & Associates, P.L.
P.O. Box 25018
Tampa, Florida 33622-5018
(813) 251-4766
(813) 251-1541 Fax
F13011443
May 23, 30, 2014 14-02244S

SECOND INSERTION

NOTICE OF FORECLOSURE SALE IN THE CIRCUIT COURT OF THE 12TH JUDICIAL CIRCUIT, IN AND FOR SARASOTA COUNTY, FLORIDA
CIVIL DIVISION
CASE NO. 2013 CA 004570 NC
FEDERAL NATIONAL MORTGAGE ASSOCIATION Plaintiff, vs. SHANE BUNDY; ET AL; Defendants,

NOTICE IS HEREBY GIVEN pursuant to a Final Judgment of Foreclosure dated May 12, 2014, and entered in Case No. 2013 CA 004570 NC, of the Circuit Court of the 12th Judicial Circuit in and for SARASOTA County, Florida, wherein FEDERAL NATIONAL MORTGAGE ASSOCIATION is Plaintiff and SHANE BUNDY; MACHELL BUNDY; UNKNOWN PERSON(S) IN POSSESSION OF THE SUBJECT PROPERTY; JOCKEY CLUB OF NORTH PORT PROPERTY OWNERS' ASSOCIATION INC.; are defendants. The Clerk of Court will sell to the highest and best bidder for cash BY ELECTRONIC SALE AT: WWW.SARASOTA.REALFORECLOSE.COM, at 9:00 A.M., on the 17 day of June, 2014, the following described property as set forth in said Final Judgment, to wit:

LOT 12, BLOCK 2631, 52ND ADDITION TO PORT CHARLOTTE SUBDIVISION, ACCORDING TO THE PLAT THEREOF, RECORDED IN PLAT BOOK 21, PAGE 13, OF THE PUBLIC RECORDS OF SARASOTA COUNTY, FLORIDA.

A person claiming an interest in the surplus from the sale, if any, other than the property owner as of the date of the lis pendens must file a claim within 60 days after the sale.

If you are a person with a disability who needs any accommodation in order to participate in this proceeding, you are entitled, at no cost to you, to the provision of certain assistance. Please contact the Sarasota County Jury Office, P.O. Box 3079, Sarasota, Florida 34230-3079, (941)861-7400, at least seven (7) days before your scheduled court appearance, or immediately upon receiving this notification if the time before the scheduled appearance is less than seven (7) days; if you are hearing or voice impaired, call 711.

Dated this 16 day of May, 2014.
Eric M. Knopp, Esq.
Bar No.: 709921

Submitted by:
Kahane & Associates, P.A.
8201 Peters Road,
Ste.3000
Plantation, FL 33324
Telephone: (954) 382-3486
Telefacsimile: (954) 382-5380
Designated service email:
notice@kahaneandassociates.com
File No.: 13-01671 SET
V1.20140101
May 23, 30, 2014 14-02298S

SECOND INSERTION

NOTICE OF TERMINATION OF GUARDIANSHIP IN THE CIRCUIT COURT FOR SARASOTA COUNTY, FLORIDA PROBATE DIVISION
File No. 2013-GA-002128 NC
IN RE: GUARDIANSHIP OF JOHN CHRISTIAN NEEL

The administration of the Guardianship of JOHN CHRISTIAN NEEL, File Number 2013-GA-002128, is currently pending in the Circuit Court for Sarasota County, Florida, Probate Division, the address of which is P.O. Box 3079, Sarasota, Florida 34230. The name and address of the court appointed successor co-guardians are JENNIFER NEEL and MELISSA BETH WEAVER, c/o P.O. Box 3018, Sarasota, Florida 34230. The name and address of the co-guardians' attorney are set forth below.

JENNIFER NEEL and MELISSA BETH WEAVER have been appointed as the co-guardians of JOHN CHRISTIAN NEEL by a court of competent jurisdiction, in Bergen County, New Jersey, Case No. P-503-13. The co-guardians' addresses are 1 Circle Lane, Rutherford, New Jersey 07070, and 6001 Crystal Springs Court, Greensboro, North Carolina 27410, respectively, and the name and address of the co-guardians' attorney are SHIRLEY B. WHITENACK, ESQ., 220 Park Avenue, P.O. Box 991, Florham Park, New Jersey 07932.

ALL INTERESTED PERSONS ARE NOTIFIED THAT:
A Petition for Discharge has been filed upon the grounds of a change of domicile for the Ward. Thirty days from the date of the first publication of this notice, the co-guardians will apply for discharge. At that time, the jurisdiction of the Ward will be transferred to Bergen County, New Jersey.

All persons on whom this notice is served who have objections to the discharge of the co-guardians shall file such objections with this court WITHIN THE LATER OF THIRTY DAYS FROM THE DATE OF SERVICE OF THE PETITION FOR DISCHARGE OR THE DATE OF THE FIRST PUBLICATION OF NOTICE.

Any objection shall be in writing and shall state with particularity each item to which the objection is directed and the grounds on which the objection is based. Within ninety days after the filing of an objection, a notice of hearing thereon shall be served or the objection shall be abandoned. ALL OBJECTIONS NOT SO FILED WILL BE FOREVER BARRED.

The date of the first publication of this Notice is May 23, 2014.

JENNIFER NEEL
c/o P.O. Box 3018
Sarasota, Florida 34230
Co-Guardians
MELISSA BETH WEAVER
c/o P.O. Box 3018
Sarasota, Florida 34230
Co-Guardians
Attorney for Co-Guardians:
MATTHEW B. MAYPER
Florida Bar No. 0956820
FERGUSON, SKIPPER, SHAW,
KEYSER, BARON & TIRABASSI, P.A.
115 Ringling Boulevard,
10th Floor
P.O. Box 3018
Sarasota, Florida 34230-3018
(941) 957-1900
mmayper@fergusonkipper.com
3392404.26517
May 23, 30, 2014 14-02329S

SECOND INSERTION

NOTICE TO CREDITORS IN THE CIRCUIT COURT FOR SARASOTA COUNTY, FLORIDA PROBATE DIVISION
File No. 2014 CP 1019 NC
Division Probate
IN RE: ESTATE OF CAROL M. SKUTNIK, Deceased.

The administration of the estate of Carol M. Skutnik, deceased, whose date of death was February 2, 2014, is pending in the Circuit Court for Sarasota County, Florida, Probate Division, the address of which is P.O. Box 3079, Sarasota, Florida 34230-3079. The names and addresses of the personal representative and the personal representative's attorney are set forth below.

All creditors of the decedent and other persons having claims or demands against decedent's estate on whom a copy of this notice is required to be served must file their claims with this court WITHIN THE LATER OF 3 MONTHS AFTER THE TIME OF THE FIRST PUBLICATION OF THIS NOTICE OR 30 DAYS AFTER THE DATE OF SERVICE OF A COPY OF THIS NOTICE ON THEM.

All other creditors of the decedent and other persons having claims or demands against decedent's estate must file their claims with this court WITHIN 3 MONTHS AFTER THE DATE OF THE FIRST PUBLICATION OF THIS NOTICE.

ALL CLAIMS NOT FILED WITHIN THE TIME PERIODS SET FORTH IN SECTION 733.702 OF THE FLORIDA PROBATE CODE WILL BE FOREVER BARRED.

NOTWITHSTANDING THE TIME PERIODS SET FORTH ABOVE, ANY CLAIM FILED TWO (2) YEARS OR MORE AFTER THE DECEDENT'S DATE OF DEATH IS BARRED.

The date of first publication of this notice is May 23, 2014.

Personal Representative:
Joseph H. Skutnik
34 Quirico Drive
Pittsfield, Massachusetts 01201
Attorney for Personal Representative:
Bradley D. Magee, Esq.
Attorney for Joseph H. Skutnik
Florida Bar No. 861730
BRADLEY D. MAGEE, ATTORNEY AT LAW, P.L.
P.O. Box 3
Osprey, FL 34229
Telephone: (941) 918-9894
Email: magee-law@comcast.net
May 23, 30, 2014 14-02266S

SECOND INSERTION

RE-NOTICE OF FORECLOSURE SALE IN THE CIRCUIT COURT OF THE 12TH JUDICIAL CIRCUIT, IN AND FOR SARASOTA COUNTY, FLORIDA
CIVIL DIVISION:
CASE NO.: 2008 CA 002561 NC
AURORA LOAN SERVICES, LLC, Plaintiff, vs. JOSEPH GARY RUBY; MORTGAGE ELECTRONIC REGISTRATION SYSTEMS INCORPORATED AS A NOMINEE FOR CENTURY BANK, F.S.B.; KRISTEN ROCKS; UNKNOWN SPOUSE OF KRISTEN ROCKS; JOHN DOE; JANE DOE AS UNKNOWN TENANT(S) IN POSSESSION OF THE SUBJECT PROPERTY, Defendants.

NOTICE IS HEREBY GIVEN pursuant to an Order Resetting Foreclosure Sale dated the 8th day of May, 2014, and entered in Case No. 2008 CA 002561 NC, of the Circuit Court of the 12TH Judicial Circuit in and for Sarasota County, Florida, wherein AURORA LOAN SERVICES, LLC is the Plaintiff and JOSEPH GARY RUBY; MORTGAGE ELECTRONIC REGISTRATION SYSTEMS INCORPORATED AS A NOMINEE FOR CENTURY BANK, F.S.B.; KRISTEN ROCKS; UNKNOWN SPOUSE OF KRISTEN ROCKS; JOHN DOE AND UNKNOWN TENANT(S) IN POSSESSION OF THE SUBJECT PROPERTY are defendants. The Clerk of this Court shall sell to the highest and best bidder for cash electronically at www.sarasota.realforeclose.com, at 9:00 AM on the 12th day of June, 2014, the following described property as set forth in said Final Judgment, to wit:

SEE EXHIBIT "A" ATTACHED BEGIN AT THE MOST NORTHERLY CORNER OF LOT 23, BLOCK F, LIDO C, AS PER PLAT THEREOF RECORDED IN PLAT BOOK 5, PAGES 3 AND 3A, OF THE PUBLIC RECORDS OF SARASOTA COUNTY, FLORIDA; THENCE S.9°47'W ALONG THE EAST-ERLY LINE OF SAID LOT, 190.3 FEET TO THE SOUTH-EASTERLY CORNER OF SAID LOT; THENCE SOUTHERLY ALONG THE EASTERLY LINE OF LOT 22, ALONG A CURVE TO THE RIGHT WITH A RADIUS OF 249.37 FEET ALONG

A CHORD WHICH BEARS S.12°39'W, A DISTANCE OF 25 FEET; THENCE N. 68°26'W, 113.29 FEET MORE OR LESS, TO A POINT ON THE WEST-ERLY LINE OF LOT 23, SAID POINT BEING LOCATED 26.5 FEET NORTHERLY FROM THE SOUTHWESTERLY CORNER OF SAID LOT 23; THENCE NORTHERLY ALONG SAID WESTERLY LINE OF LOT 23, ALONG A CURVE TO THE RIGHT WITH A RADIUS OF 237.94 FEET, THE CHORD OF WHICH BEARS N. 33°53'E, A DISTANCE OF 85.9 FEET TO THE END OF SAID CURVE; THENCE CONTINUE N. 44°18'E, ALONG SAID LOT LINE, A DISTANCE OF 137.2 FEET TO THE POINT OF BEGINNING; BEING A PART OF LOTS 22 AND 23 BLOCK F, OF SAID LIDO C, ALL LYING, BEING AND SITUATE IN THE COUNTY OF SARASOTA, STATE OF FLORIDA.

ANY PERSON CLAIMING AN INTEREST IN THE SURPLUS FROM THE SALE, IF ANY, OTHER THAN THE PROPERTY OWNER AS OF THE DATE OF THE LIS PENDENS MUST FILE A CLAIM WITHIN 60 DAYS AFTER THE SALE.

If you are a person with a disability who needs any accommodation in order to participate in this proceeding, you are entitled, at no cost to you, to the provision of certain assistance. Please contact the Sarasota County Jury Office, P.O. Box 3079, Sarasota, Florida 34230-3079, (941)861-7400, at least seven (7) days before your scheduled court appearance, or immediately upon receiving this notification if the time before the scheduled appearance is less than seven (7) days; if you are hearing or voice impaired, call 711.

Dated this 16 day of May, 2014.
By: Jennifer Nicole Tarquinio
Bar #99192
Choice Legal Group, P.A.
P.O. Box 9908
Fort Lauderdale, FL 33310-0908
Telephone: (954) 453-0365
Facsimile: (954) 771-6052
Toll Free: 1-800-441-2438
DESIGNATED PRIMARY E-MAIL FOR SERVICE PURSUANT TO FLA R. JUD. ADMIN 2.516
eservice@clelegalgroup.com
08-06022
May 23, 30, 2014 14-02292S

SECOND INSERTION

NOTICE OF SALE IN THE CIRCUIT COURT OF THE TWELFTH JUDICIAL CIRCUIT IN AND FOR SARASOTA COUNTY, FLORIDA
Case No. 2009 CA 016885 NC
DEUTSCHE BANK NATIONAL TRUST COMPANY, AS TRUSTEE OF THE INDYMAC INDX MORTGAGE TRUST, et al Plaintiff, vs. SHERRY STONEBAKER, et al Defendants.

NOTICE IS HEREBY GIVEN pursuant to a Final Judgment of Foreclosure entered in the above-styled case, Case No. 2009 CA 016885 NC, in the Circuit Court in and for Sarasota County, Florida, that I will sell to the highest and best bidder for cash online at www.sarasota.realforeclose.com at 9:00 a.m., on the 16th day of June, 2014, the following described property:

Lot 65, Palmer Glen, Phase I, as per plat thereof recorded in Plat Book 40, Pages 44, 44A through 44G of the Public Records of Sarasota County, Florida.

If you are a person with a disability who needs any accommodation in order to participate in this proceeding, you are entitled, at no cost to you, to the provision of certain assistance. Please contact the Sarasota County Jury Office, P.O. Box 3079, Sarasota, Florida 34230-3079, (941)861-7400, at least seven (7) days before your scheduled court appearance, or immediately upon receiving this notification if the time before the scheduled appearance is less than seven (7) days; if you are hearing or voice impaired, call 711.

Dated this 16 day of May, 2014.
By: /s/ Sharon S. Vander Wulp
SHARON S. VANDER WULP, ESQUIRE
712 Shamrock Boulevard
Venice, FL 34293
(941) 492-2100 phone
(941) 492-3116 fax
Florida Bar No. 618608
Counsel for Plaintiff
Primary: office@svwpa.com
Secondary: arman@svwpa.com
May 23, 30, 2014 14-02257S

PUBLISH YOUR LEGAL NOTICES IN THE BUSINESS OBSERVER
(813) 221-9505 Hillsborough, Pasco
(727) 447-7784 Pinellas
(941) 906-9386 Manatee, Sarasota, Lee
(239) 263-0122 Collier
(941) 249-4900 Charlotte
(407) 654-5500 Orange



SECOND INSERTION

NOTICE OF SALE
IN THE CIRCUIT COURT OF THE
TWELFTH JUDICIAL CIRCUIT OF
THE STATE OF FLORIDA, IN AND
FOR SARASOTA COUNTY
CIVIL DIVISION
CASE NO.

58-2008-CA-009574-XXXX-NC
U.S. BANK NATIONAL
ASSOCIATION, AS TRUSTEE FOR
HARBORVIEW 2006-4 TRUST
FUND,
Plaintiff, vs.
WILLIAM C. JONES; UNKNOWN
SPOUSE OF WILLIAM C.
JONES IF ANY; ANY AND
ALL UNKNOWN PARTIES
CLAIMING BY, THROUGH,
UNDER, AND AGAINST THE
HEREIN NAMED INDIVIDUAL
DEFENDANT(S) WHO ARE
NOT KNOWN TO BE DEAD
OR ALIVE, WHETHER SAID
UNKNOWN PARTIES MAY CLAIM
AN INTEREST AS SPOUSES,
HEIRS, DEVISEES, GRANTEEES
OR OTHER CLAIMANTS; STATE
OF FLORIDA, DEPARTMENT
OF REVENUE; JOHN DOE
AND JANE DOE AS UNKNOWN
TENANTS IN POSSESSION;
Defendant(s)

Notice is hereby given that, pursuant to a Final Summary Judgment of Foreclosure entered on 10/29/2013 in the above styled cause, in the Circuit Court of Sarasota County, Florida, the office of Karen E. Rushing, clerk of the circuit court will sell the property situated in Sarasota County, Florida, described as:

LOT 12, BLOCK 234, EIGHTH ADDITION TO PORT CHARLOTTE SUBDIVISION, AS PER PLAT THEREOF RECORDED IN PLAT BOOK 12, PAGE 20, 20A THROUGH 20Z2, OF THE PUBLIC RECORDS OF SARASOTA COUNTY, FLORIDA.

at public sale, to the highest and best bidder, for cash, www.sarasota.realforeclose.com at 9:00 o'clock, A.M., on June 18, 2014

Any person claiming an interest in the surplus from the sale, if any, other than the property owner as of the date of the lis pendens, must file a claim within 60 days after the sale.

If you are a person with a disability who needs any accommodation in order to participate in this proceeding, you are entitled, at no cost to you, to the provision of certain assistance. Please contact the Sarasota County Jury Office, P.O. Box 3079, Sarasota, Florida 34230-3079, (941)861-7400, at least seven (7) days before your scheduled court appearance, or immediately upon receiving this notification if the time before the scheduled appearance is less than seven (7) days; if you are hearing or voice impaired, call 711.

ATTORNEY FOR PLAINTIFF
By /s/ Josh D. Donnelly
Josh D. Donnelly
Florida Bar #64788

Date: 05/17/2014
THIS INSTRUMENT PREPARED BY:
Law Offices Of Daniel C. Consuegra
9204 King Palm Drive
Tampa, FL 33619-1328
Phone: 813-915-8660
Attorneys for Plaintiff
156850-T
May 23, 30, 2014 14-02295S

SECOND INSERTION

RE-NOTICE OF
FORECLOSURE SALE
IN THE CIRCUIT COURT OF THE
TWELFTH JUDICIAL CIRCUIT, IN
AND FOR SARASOTA COUNTY,
FLORIDA
CIVIL DIVISION
CASE NO.:

2008 CA 009693 NC
PNC BANK, NATIONAL
ASSOCIATION SUCCESSOR BY
MERGER TO NATIONAL CITY
BANK SUCCESSOR BY MERGER
TO NATIONAL CITY BANK OF
INDIANA DBA NATIONAL CITY
MORTGAGE
Plaintiff, vs.
HUBERT WALKIEWICZ, et al
Defendants.

RE-NOTICE IS HEREBY GIVEN pursuant to an Order Granting Plaintiff's Motion to Reschedule Foreclosure Sale filed May 8, 2014, and entered in Case No. 2008 CA 009693 NC of the Circuit Court of the TWELFTH Judicial Circuit in and for SARASOTA COUNTY, Florida, wherein PNC BANK, NATIONAL ASSOCIATION SUCCESSOR BY MERGER TO NATIONAL CITY BANK SUCCESSOR BY MERGER TO NATIONAL CITY BANK OF INDIANA DBA NATIONAL CITY MORTGAGE, is Plaintiff, and HUBERT WALKIEWICZ, et al are Defendants, the clerk will sell to the highest and best bidder for cash, beginning at 09:00 AM at www.sarasota.realforeclose.com, in accordance with Chapter 45, Florida Statutes, on the 12 day of June, 2014, the following described property as set forth in said Lis Pendens, to wit:

LOT 18, Block 698, of 17th Addition to Port Charlotte Subdivision, according to the Plat thereof, as recorded in Plat Book 13, Page 16, or the Public Records of Sarasota County, Florida.

Any person claiming an interest in the surplus funds from the sale, if any, other than the property owner as of the date of the lis pendens must file a claim within 60 days after the sale.

If you are a person with a disability who needs any accommodation in order to participate in this proceeding, you are entitled, at no cost to you, to the provision of certain assistance.

Please contact the Sarasota County Jury Office, P.O. Box 3079, Sarasota, Florida 34230-3079, (941)861-7400, at least seven (7) days before your scheduled court appearance, or immediately upon receiving this notification if the time before the scheduled appearance is less than seven (7) days; if you are hearing or voice impaired, call 711.

Dated: May 19, 2014
By: /s/ Heather Griffiths
Phelan Hallinan, PLC
Heather Griffiths, Esq.,
Florida Bar No. 0091444
Emilio R. Lenzi, Esq.,
Florida Bar No. 0668273

Phelan Hallinan, PLC
Attorneys for Plaintiff
2727 West Cypress Creek Road
Ft. Lauderdale, FL 33309
Tel: 954-462-7000
Fax: 954-462-7001
Service by email:
FL.Service@PhelanHallinan.com
PH # 47910
May 23, 30, 2014 14-02303S

SECOND INSERTION

NOTICE OF FORECLOSURE SALE
IN THE CIRCUIT COURT OF THE
TWELFTH JUDICIAL CIRCUIT, IN
AND FOR SARASOTA COUNTY,
FLORIDA

CASE NO. 2009 CA 016241 NC
THE BANK OF NEW YORK
MELLON FKA THE BANK OF
NEW YORK, AS TRUSTEE FOR
THE CERTIFICATEHOLDERS
CWALT, INC., ALTERNATIVE
LOAN TRUST 2006-21CB,
MORTGAGE PASS-THROUGH
CERTIFICATES, SERIES
2006-21CB,
Plaintiff, vs.
CARMEN CERVINO; PABLO
CERVINO, et al.
Defendants

NOTICE IS HEREBY GIVEN pursuant to a Final Judgment of Foreclosure dated April 23, 2014, and entered in Case No. 2009 CA 016241 NC, of the Circuit Court of the Twelfth Judicial Circuit in and for SARASOTA County, Florida. THE BANK OF NEW YORK MELLON FKA THE BANK OF NEW YORK, AS TRUSTEE FOR THE CERTIFICATEHOLDERS CWALT, INC., ALTERNATIVE LOAN TRUST 2006-21CB, MORTGAGE PASS-THROUGH CERTIFICATES, SERIES 2006-21CB, is Plaintiff and CARMEN CERVINO; PABLO CERVINO; CEDAR GROVE HOMEOWNERS ASSOCIATION, INC.; CITIFINANCIAL EQUITY SERVICES, INC., are defendants. The Clerk of Court will sell to the highest and best bidder for cash via the Internet at www.sarasota.realforeclose.com, at 9:00 a.m., on the 23rd day of June, 2014, the following described property as set forth in said Final Judgment, to wit:

LOT 1, BLOCK C, FIRST ADDITION TO CEDAR GROVE, ACCORDING TO THE PLAT THEREOF RECORDED IN PLAT BOOK 1, PAGE 65 OF THE PUBLIC RECORDS OF SARASOTA COUNTY, FLORIDA.

Any person claiming an interest in the surplus from the sale, if any, other than the property owner as of the date of the Lis Pendens must file a claim within 60 days after the sale.

If you are a person with a disability who needs any accommodation in order to participate in this proceeding, you are entitled, at no cost to you, to the provision of certain assistance. Please contact the Sarasota County Jury Office, P.O. Box 3079, Sarasota, Florida 34230-3079, (941)861-7400, at least seven (7) days before your scheduled court appearance, or immediately upon receiving this notification if the time before the scheduled appearance is less than seven (7) days; if you are hearing or voice impaired, call 711.

Mark C. Elia, Esq.
Florida Bar #: 695734
Email: MCElia@vanlawfl.com

VAN NESS LAW FIRM, PLC
1239 N. Newport Center Drive,
Suite 110
Deerfield Beach, Florida 33442
Ph: (954) 571-2031
Fax: (954) 571-2033
PRIMARY EMAIL:
Pleadings@vanlawfl.com
May 23, 30, 2014 14-02306S

SECOND INSERTION

NOTICE OF FORECLOSURE SALE
IN THE CIRCUIT COURT OF THE
12TH JUDICIAL CIRCUIT, IN
AND FOR SARASOTA COUNTY,
FLORIDA

CIVIL DIVISION:
CASE NO.: 2013 CA 004554 NC
JPMORGAN CHASE BANK,
NATIONAL ASSOCIATION,
SUCCESSOR BY MERGER TO
CHASE HOME FINANCE LLC,
Plaintiff, vs.
ATHANASIOS MARKADAKIS;
ANNA MARKADAKIS; UNKNOWN
TENANT IN POSSESSION OF THE
SUBJECT PROPERTY,
Defendants.

NOTICE IS HEREBY GIVEN pursuant to Final Judgment of Foreclosure dated the 12th day of May, 2014, and entered in Case No. 2013 CA 004554 NC, of the Circuit Court of the 12TH Judicial Circuit in and for Sarasota County, Florida, wherein U.S. BANK NATIONAL ASSOCIATION NOT IN ITS INDIVIDUAL CAPACITY, BUT SOLELY AS LEGAL TITLE TRUSTEE FOR LVS TITLE TRUST I is the Plaintiff and ATHANASIOS MARKADAKIS; ANNA MARKADAKIS and UNKNOWN TENANT (S) IN POSSESSION OF THE SUBJECT PROPERTY are defendants. The Clerk of this Court shall sell to the highest and best bidder for cash electronically at www.sarasota.realforeclose.com at 9:00 AM on the 16th day of June, 2014, the following described property as set forth in said Final Judgment, to wit:

LOTS 3348 AND 3349, SOUTH VENICE, UNIT NO. 12, ACCORDING TO THE PLAT THEREOF, AS RECORDED IN PLAT BOOK 6, PAGE 48, OF THE PUBLIC RECORDS OF SARASOTA COUNTY, FLORIDA ANY PERSON CLAIMING AN INTEREST IN THE SURPLUS FROM THE SALE, IF ANY, OTHER THAN THE PROPERTY OWNER AS OF THE DATE OF THE LIS PENDENS MUST FILE A CLAIM WITHIN 60 DAYS AFTER THE SALE.

If you are a person with a disability who needs any accommodation in order to participate in this proceeding, you are entitled, at no cost to you, to the provision of certain assistance. Please contact the Sarasota County Jury Office, P.O. Box 3079, Sarasota, Florida 34230-3079, (941)861-7400, at least seven (7) days before your scheduled court appearance, or immediately upon receiving this notification if the time before the scheduled appearance is less than seven (7) days; if you are hearing or voice impaired, call 711.

Dated this 19 day of May, 2014.
By: Jennifer Nicole Tarquinio
Bar #99192

Choice Legal Group, P.A.
P.O. Box 9908
Fort Lauderdale, FL 33310-0908
Telephone: (954) 453-0365
Facsimile: (954) 771-6052
Toll Free: 1-800-441-2438
DESIGNATED PRIMARY E-MAIL
FOR SERVICE PURSUANT TO FLA
R. JUD. ADMIN 2.516
eservice@clegalgroup.com
11-07168
May 23, 30, 2014 14-02314S

SECOND INSERTION

NOTICE OF SALE
IN THE CIRCUIT CIVIL COURT OF
THE TWELFTH JUDICIAL
CIRCUIT OF FLORIDA, IN AND
FOR SARASOTA COUNTY
CIVIL DIVISION
Case No. 58-2010-CA-006383 NC

Division C
WELLS FARGO BANK, N.A.
Plaintiff, vs.
SAMUEL ISRAEL KAPLAN;
PELE PARSONS WYLDE; PELE
PARSONS WYLDE, TRUSTEE OF
THE PELE PARSONS WYLDE
TRUST DATED APRIL 26, 2002;
UNKNOWN BENEFICIARY OF
THE PELE PARSONS WYLDE
TRUST DATED APRIL 26, 2002;
UNKNOWN TRUSTEE OF THE
PELE PARSONS WYLDE TRUST
DATED APRIL 26, 2002, WELLS
FARGO BANK, N.A.; UNKNOWN
SPOUSE OF PELE PARSONS
WYLDE; UNKNOWN SPOUSE OF
SAMUEL ISRAEL KAPLAN, AND
UNKNOWN TENANTS/OWNERS,
Defendants.

Notice is hereby given, pursuant to Final Judgment of Foreclosure for Plaintiff entered in this cause on June 3, 2013, in the Circuit Court of Sarasota County, Florida, The Clerk of the Court will sell the property situated in Sarasota County, Florida described as:

LOTS 20 AND 21, BLOCK 13, SARASOTA BEACH, ACCORDING TO THE PLAT THEREOF, RECORDED IN PLAT BOOK 1, PAGES 76 THROUGH 81, OF THE PUBLIC RECORDS OF SARASOTA COUNTY, FLORIDA.

and commonly known as: 425 AVENIDA DEL NORTE, SARASOTA, FL 34242; including the building, appurtenances, and fixtures located therein, at public sale, to the highest and best bidder, for cash, Sales are held online at: https://www.sarasota.realforeclose.com, on June 16, 2014 at 9:00 A.M.

Any persons claiming an interest in the surplus from the sale, if any, other than the property owner as of the date of the lis pendens must file a claim within 60 days after the sale.

If you are a person with a disability who needs any accommodation in order to participate in this proceeding, you are entitled, at no cost to you, to the provision of certain assistance. Please contact the Sarasota County Jury Office, P.O. Box 3079, Sarasota, Florida 34230-3079, (941)861-7400, at least seven (7) days before your scheduled court appearance, or immediately upon receiving this notification if the time before the scheduled appearance is less than seven (7) days; if you are hearing or voice impaired, call 711.

Karen E. Rushing
By: Frances Grace Cooper, Esquire
Attorney for Plaintiff

Edward B. Pritchard
(813) 229-0900 x1309
Kass Shuler, P.A.
P.O. Box 800
Tampa, FL 33601-0800
ForeclosureService@kasslaw.com
317300/1007880/
May 23, 30, 2014 14-02318S

SECOND INSERTION

NOTICE OF RESCHEDULED
FORECLOSURE SALE
IN THE CIRCUIT COURT OF THE
TWELFTH JUDICIAL CIRCUIT
IN AND FOR SARASOTA COUNTY,
FLORIDA
CIVIL ACTION
CASE NO.:

2007 CA 012568 NC
DIVISION: C
SOUTHTRUST MORTGAGE,
Plaintiff, vs.
GABRIEL REED , et al,
Defendant(s).

NOTICE IS HEREBY GIVEN pursuant to an Order Rescheduling Foreclosure Sale dated May 7, 2014 and entered in Case No. 2007 CA 012568 NC of the Circuit Court of the TWELFTH Judicial Circuit in and for SARASOTA County, Florida wherein WELLS FARGO BANK, NA, Plaintiff name has changed pursuant to order previously entered, is the Plaintiff and GABRIEL REED; ANY AND ALL UNKNOWN PARTIES CLAIMING BY, THROUGH, UNDER, AND AGAINST THE HEREIN NAMED INDIVIDUAL DEFENDANT(S) WHO ARE NOT KNOWN TO BE DEAD OR ALIVE, WHETHER SAID UNKNOWN PARTIES MAY CLAIM AN INTEREST AS SPOUSES, HEIRS, DEVISEES, GRANTEEES, OR OTHER CLAIMANTS; STATE OF FLORIDA - DEPARTMENT OF REVENUE; TENANT #1; TENANT #2 are the Defendants, The Clerk will sell to the highest and best bidder for cash at WWW.SARASOTA.REALFORECLOSE.COM at 9:00AM, on 06/19/2014, the following described property as set forth in said Final Judgment:

THE EAST 100 FEET OF THE SOUTH 1/2 OF LOT 3, BLOCK A, RIVERSIDE PARK, RECORDED IN PLAT BOOK 1, PAGE 13, OF THE PUBLIC RECORDS OF SARASOTA COUNTY, FLORIDA

A/K/A 3061 WEST PLACE, SARASOTA, FL 34234

Any person claiming an interest in the surplus from the sale, if any, other than the property owner as of the date of the Lis Pendens must file a claim within sixty (60) days after the sale.

If you are a person with a disability who needs any accommodation in order to participate in this proceeding, you are entitled, at no cost to you, to the provision of certain assistance. Please contact the Sarasota County Jury Office, P.O. Box 3079, Sarasota, Florida 34230-3079, (941)861-7400, at least seven (7) days before your scheduled court appearance, or immediately upon receiving this notification if the time before the scheduled appearance is less than seven (7) days; if you are hearing or voice impaired, call 711.

By: Amy Recla
Florida Bar No. 102811

Ronald R Wolfe & Associates, P.L.
P.O. Box 25018
Tampa, Florida 33622-5018
(813) 251-4766
(813) 251-1541 Fax
F07046511
May 23, 30, 2014 14-02307S

SECOND INSERTION

RE-NOTICE OF
FORECLOSURE SALE
IN THE CIRCUIT COURT OF THE
TWELFTH JUDICIAL CIRCUIT, IN
AND FOR SARASOTA COUNTY,
FLORIDA
CIVIL DIVISION
CASE NO.:

2012 CA 004077 NC
U.S. BANK NATIONAL
ASSOCIATION, AS TRUSTEE FOR
CREDIT SUISSE FIRST BOSTON
MORTGAGE SECURITIES
CORP., CSAB MORTGAGE-
BACKED TRUST 2006-3, CSAB
MORTGAGE-BACKED PASS-
THROUGH CERTIFICATES,
2006-3
Plaintiff, vs.
ARTHUR LEITC FRANCO, et al
Defendants.

RE-NOTICE IS HEREBY GIVEN pursuant to an Order Granting Plaintiff's Motion to Reschedule Foreclosure Sale filed May 5, 2014 and entered in Case No. 2012 CA 004077 NC of the Circuit Court of the TWELFTH Judicial Circuit in and for SARASOTA COUNTY, Florida, wherein U.S. BANK NATIONAL ASSOCIATION, AS TRUSTEE FOR CREDIT SUISSE FIRST BOSTON MORTGAGE SECURITIES CORP., CSAB MORTGAGE-BACKED TRUST 2006-3, CSAB MORTGAGE-BACKED PASS-THROUGH CERTIFICATES, 2006-3, is Plaintiff, and ARTHUR LEITC FRANCO, et al are Defendants, the clerk will sell to the highest and best bidder for cash, beginning at 09:00 AM at www.sarasota.realforeclose.com, in accordance with Chapter 45, Florida Statutes, on the 12 day of June, 2014, the following described property as set forth in said Lis Pendens, to wit:

Lot 1552, Lake Sarasota, Unit # 17 Subdivision according to the Plat thereof, as recorded in Plat Book 9, Page 23, Public Records of Sarasota County, Florida.

Any person claiming an interest in the surplus funds from the sale, if any, other than the property owner as of the date of the lis pendens must file a claim within 60 days after the sale.

If you are a person with a disability who needs any accommodation in order to participate in this proceeding, you are entitled, at no cost to you, to the provision of certain assistance. Please contact the Sarasota County Jury Office, P.O. Box 3079, Sarasota, Florida 34230-3079, (941)861-7400, at least seven (7) days before your scheduled court appearance, or immediately upon receiving this notification if the time before the scheduled appearance is less than seven (7) days; if you are hearing or voice impaired, call 711.

Dated: May 19, 2014
By: /s/ Heather Griffiths
Phelan Hallinan, PLC
Heather Griffiths, Esq.,
Florida Bar No. 0091444
Emilio R. Lenzi, Esq.,
Florida Bar No. 0668273

Phelan Hallinan, PLC
Attorneys for Plaintiff
2727 West Cypress Creek Road
Ft. Lauderdale, FL 33309
Tel: 954-462-7000
Fax: 954-462-7001
Service by email:
FL.Service@PhelanHallinan.com
May 23, 30, 2014 14-02319S

SECOND INSERTION

RE-NOTICE OF
FORECLOSURE SALE
IN THE CIRCUIT COURT OF THE
12TH JUDICIAL CIRCUIT, IN
AND FOR SARASOTA COUNTY,
FLORIDA
CIVIL DIVISION:
CASE NO.:

2012 CA 008063 NC
CITIMORTGAGE, INC.,
Plaintiff, vs.
EDWIN F. GRISALES; CITY
OF SARASOTA, A MUNICIPAL
CORPORATION; GLORIA
INES CARDONA; CAROLINA
GRISALES; JESUS GRISALES
A/K/A JESUS M. GRISALES;
UNKNOWN TENANT IN
POSSESSION OF THE SUBJECT
PROPERTY,
Defendants.

NOTICE IS HEREBY GIVEN pursuant to an Order Resetting Foreclosure Sale dated the 17th day of April, 2014, and entered in Case No. 2012 CA 008063 NC, of the Circuit Court of the 12TH Judicial Circuit in and for Sarasota County, Florida, wherein CITIMORTGAGE, INC. is the Plaintiff and EDWIN F. GRISALES; CITY OF SARASOTA, A MUNICIPAL CORPORATION; GLORIA INES CARDONA; CAROLINA GRISALES; JESUS GRISALES A/K/A JESUS M. GRISALES and UNKNOWN TENANT (S) IN POSSESSION OF THE SUBJECT PROPERTY are defendants. The Clerk of this Court shall sell to the highest and best bidder for cash electronically at www.sarasota.realforeclose.com at 9:00 AM on the 16th day of June, 2014, the following described property as set forth in said Final Judgment, to wit:

LOT 19, BLOCK 1934, 41ST

ADDITION TO PORT CHARLOTTE, AS PER PLAT THEREOF, RECORDED IN PLAT BOOK 16, PAGE(S) 42, 42A THRU 42F, OF THE PUBLIC RECORDS OF SARASOTA COUNTY, FLORIDA

ANY PERSON CLAIMING AN INTEREST IN THE SURPLUS FROM THE SALE, IF ANY, OTHER THAN THE PROPERTY OWNER AS OF THE DATE OF THE LIS PENDENS MUST FILE A CLAIM WITHIN 60 DAYS AFTER THE SALE.

If you are a person with a disability who needs any accommodation in order to participate in this proceeding, you are entitled, at no cost to you, to the provision of certain assistance. Please contact the Sarasota County Jury Office, P.O. Box 3079, Sarasota, Florida 34230-3079, (941)861-7400, at least seven (7) days before your scheduled court appearance, or immediately upon receiving this notification if the time before the scheduled appearance is less than seven (7) days; if you are hearing or voice impaired, call 711.

Dated this 19 day of May, 2014.
By: Jennifer Nicole Tarquinio
Bar #99192

Choice Legal Group, P.A.
P.O. Box 9908
Fort Lauderdale, FL 33310-0908
Telephone: (954) 453-0365
Facsimile: (954) 771-6052
Toll Free: 1-800-441-2438
DESIGNATED PRIMARY E-MAIL
FOR SERVICE PURSUANT TO FLA
R. JUD. ADMIN 2.516
eservice@clegalgroup.com
12-10459
May 23, 30, 2014 14-02313S

SECOND INSERTION

NOTICE OF SALE
IN THE CIRCUIT CIVIL COURT OF
THE TWELFTH JUDICIAL
CIRCUIT OF FLORIDA, IN AND
FOR SARASOTA COUNTY
CIVIL DIVISION
Case No. 58-2013-CA-002781 NC

Division A
JPMORGAN CHASE BANK,
NATIONAL ASSOCIATION
Plaintiff, vs.
LEON F. BOOKER,
STONEBROOK VERANDA
GREENS I ASSOCIATION,
INC., STONEYBROOK
VERANDA GREENS
COMMONS ASSOCIATION,
INC., STONEYBROOK GOLF &
COUNTRY CLUB OF SARASOTA,
INC., FLORIDA SOUTHERN
ROOFING & SHEET METAL, INC.,
AND UNKNOWN TENANTS/
OWNERS,
Defendants.

Notice is hereby given, pursuant to Final Judgment of Foreclosure for Plaintiff entered in this cause on May 12, 2014, in the Circuit Court of Sarasota County, Florida, The Clerk of the Court will sell the property situated in Sarasota County, Florida described as:

UNIT 1423, BUILDING 1400, OF STONEYBROOK VERANDA GREENS CONDOMINIUM I, A CONDOMINIUM, ACCORDING TO THE DECLARATION THEREOF, AS RECORDED IN OFFICIAL RECORDS BOOK 2839, AT PAGE(S) 1750, AND AS PER PLAT THEREOF RECORDED IN CONDOMINIUM BOOK

31, PAGES 27, 27A AND 27B, OF THE PUBLIC RECORDS OF SARASOTA COUNTY, FLORIDA.

and commonly known as: 9540 HIGH GATE DR UNIT 1423, SARASOTA, FL 34238; including the building, appurtenances, and fixtures located therein, at public sale, to the highest and best bidder, for cash, Sales are held online at: https://www.sarasota.realforeclose.com, on June 16, 2014 at 9:00 A.M.

Any persons claiming an interest in the surplus from the sale, if any, other than the property owner as of the date of the lis pendens must file a claim within 60 days after the sale.

If you are a person with a disability who needs any accommodation in order to participate in this proceeding, you are entitled, at no cost to you, to the provision of certain assistance. Please contact the Sarasota County Jury Office, P.O. Box 3079, Sarasota, Florida 34230-3079, (941)861-7400, at least seven (7) days before your scheduled court appearance, or immediately upon receiving this notification if the time before the scheduled appearance is less than seven (7) days; if you are hearing or voice impaired, call 711.

Karen E. Rushing
By: Frances Grace Cooper, Esquire
Attorney for Plaintiff

Edward B. Pritchard
(813) 229-0900 x1309
Kass Shuler, P.A.
P.O. Box 800
Tampa, FL 33601-0800
ForeclosureService@kasslaw.com
320400/1332602/
May 23, 30, 2014 14-02315S

SECOND INSERTION

NOTICE OF FORECLOSURE SALE IN THE CIRCUIT COURT OF THE AND FOR SARASOTA COUNTY, FLORIDA

CASE NO: 2010 CA 007176 NC JPMORGAN CHASE BANK, NATIONAL ASSOCIATION Plaintiff, vs. THOMAS W. HEFNER; ANGELA HEFNER; JPMORGAN CHASE BANK, NATIONAL ASSOCIATION, SUCCESSOR IN INTEREST TO WASHINGTON MUTUAL BANK F/K/A WASHINGTON MUTUAL BANK, FA; UNKNOWN TENANT #1; UNKNOWN TENANT #2 Defendants.

NOTICE is hereby given that the Clerk of the Circuit Court of Sarasota County, Florida, will on the 13th day of June 2014, at 9:00 a.m. at www.sarasota.realforeclose.com in accordance with Chapter 45 Florida Statutes, offer for sale and sell at public outcry to the highest and best bidder for cash, the following-described property situate in Sarasota County, Florida:

LOT(S) 2958 AND 2959, UNIT 10, SOUTH VENICE, ACCORDING TO THE PLAT THEREOF, AS RECORDED IN PLAT BOOK 6, PAGE 46, OF THE PUBLIC RECORDS OF SARASOTA COUNTY, FLORIDA

pursuant to the Final Judgment entered in a case pending in said Court, the style of which is indicated above.

Any person or entity claiming an interest in the surplus, if any, resulting from the foreclosure sale, other than the property owner as of the date of the Lis Pendens, must file a claim on same with the Clerk of Court within 60 days after the foreclosure sale.

If you are a person with a disability who needs any accommodation in order to participate in this proceeding, you are entitled, at no cost to you, to the provision of certain assistance. Please contact the Sarasota County Jury Office, P.O. Box 3079, Sarasota, Florida 34230-3079, (941)861-7400, at least seven (7) days before your scheduled court appearance, or immediately upon receiving this notification if the time before the scheduled appearance is less than seven (7) days; if you are hearing or voice impaired, call 711

DATED this 16th day of May, 2014.
John J. Bennett
Florida Bar Number: 88257
Antonio Andres Caula, Esquire
BUTLER & HOSCH, P.A.
3185 South Conway Road, Suite E
Orlando, Florida 32812
Telephone: (407) 381-5200
Fax: (407) 381-5577
Florida Bar No: 103300
aci06892@butlerandhosch.com
FLPleadings@butlerandhosch.com
B&H # 295999
May 23, 30, 2014 14-02296S

SECOND INSERTION

NOTICE OF SALE IN THE CIRCUIT COURT OF THE TWELFTH JUDICIAL CIRCUIT IN AND FOR SARASOTA COUNTY, FLORIDA

CIVIL DIVISION
Case #: 2009-CA-001387-NC
DIVISION: A

Everhome Mortgage Company Plaintiff, vs.- Bridget Ryan; Unknown Spouse of Bridget Ryan, if married; Suntrust Bank; John Doe and Jane Doe Defendant(s).

NOTICE IS HEREBY GIVEN pursuant to order rescheduling foreclosure sale or Final Judgment, entered in Civil Case No. 2009-CA-001387-NC of the Circuit Court of the 12th Judicial Circuit in and for Sarasota County, Florida, wherein Everhome Mortgage Company, Plaintiff and Bridget Ryan are defendant(s), I, Clerk of Court, Karen E. Rushing, will sell to the highest and best bidder for cash VIA THE INTERNET AT WWW.SARASOTA.REALFORECLOSE.COM, AT 9:00 A.M. on June 16, 2014, the following described property as set forth in said Final Judgment, to-wit:

LOTS 12576 & 12577, SOUTH VENICE, UNIT NO. 48, ACCORDING TO THE PLAT THEREOF, RECORDED IN PLAT BOOK 7, PAGE 12, OF THE PUBLIC RECORDS OF SARASOTA COUNTY, FLORIDA.

ANY PERSON CLAIMING AN INTEREST IN THE SURPLUS FROM THE SALE, IF ANY, OTHER THAN THE PROPERTY OWNER AS OF THE DATE OF THE LIS PENDENS MUST FILE A CLAIM WITHIN 60 DAYS AFTER THE SALE.

If you are a person with a disability who needs any accommodation in order to participate in this proceeding, you are entitled, at no cost to you, to the provision of certain assistance. Please contact the Sarasota County Jury Office, P.O. Box 3079, Sarasota, Florida 34230-3079, (941)861-7400, at least seven (7) days before your scheduled court appearance, or immediately upon receiving this notification if the time before the scheduled appearance is less than seven (7) days; if you are hearing or voice impaired, call 711.

Submitted By:
ATTORNEY FOR PLAINTIFF:
SHAPIRO, FISHMAN & GACHE, LLP
2424 North Federal Highway,
Suite 360
Boca Raton, Florida 33431
(561) 998-6700
(561) 998-6707
11-228843 FCO1 CXE
May 23, 30, 2014 14-02234S

SECOND INSERTION

NOTICE OF FORECLOSURE SALE IN THE CIRCUIT COURT OF THE TWELFTH JUDICIAL CIRCUIT IN AND FOR SARASOTA COUNTY, FLORIDA

Case No: 2013 CA 003101 NC JPMORGAN CHASE BANK NATIONAL ASSOCIATION, Plaintiff, vs. CHERYL AMENTASTRO, ET AL, Defendants.

NOTICE IS HEREBY GIVEN that pursuant to the Final Judgment of Foreclosure dated May 12, 2014 and entered in Case No. 2013-CA-003101-NC of the Circuit Court of the Twelfth Judicial Circuit in and for Sarasota County, Florida wherein, CHRISTIANA TRUST, A DIVISION OF WILMINGTON SAVINGS FUND SOCIETY, FSB, AS TRUSTEE FOR NORMANDY MORTGAGE LOAN TRUST, SERIES 2013-18, is the Plaintiff and CHERYL AMENTASTRO, ET AL are the Defendant(s), I will sell to the highest and best bidder for cash at www.sarasota.realforeclose.com at 9:00 a.m. or as soon as possible on June 18, 2014, the following described property set forth in said Final Judgment, to wit:

LOT 4, BLOCK 2503, 50th ADDITION TO PORT CHARLOTTE SUBDIVISION, ACCORDING TO THE PLAT THEREOF, AS RECORDED IN PLAT BOOK 21, PAGE 7, OF THE PUBLIC RECORDS OF SARASOTA COUNTY, FLORIDA.

Any person or entity claiming an interest in the surplus, if any, resulting from the Foreclosure Sale, other than the property owner as of the date of the Lis Pendens, must file a claim on same with the Clerk of Court within sixty (60) days after the Foreclosure Sale.

If you are a person with a disability who needs any accommodation in order to participate in this proceeding, you are entitled, at no cost to you, to the provision of certain assistance. Please contact the Sarasota County Jury Office, P.O. Box 3079, Sarasota, Florida 34230-3079, (941)861-7400, at least seven (7) days before your scheduled court appearance, or immediately upon receiving this notification if the time before the scheduled appearance is less than seven (7) days; if you are hearing or voice impaired, call 711.

DATED May 19, 2014
/s/ Nancy Alvarez
Nancy Alvarez, Esq.
Florida Bar No. 068122
Lender Legal Services, LLC
201 East Pine Street, Suite 730
Orlando, Florida 32801
Tel: (407) 730-4644
Fax: (888) 337-3815
Attorney for Plaintiff
nalvarez@lenderlegal.com
EService@LenderLegal.com
May 23, 30, 2014 14-02301S

SECOND INSERTION

NOTICE OF SALE IN THE CIRCUIT CIVIL COURT OF THE TWELFTH JUDICIAL CIRCUIT OF FLORIDA, IN AND FOR SARASOTA COUNTY

CIVIL DIVISION
Case No. 58-2012-CA-003300 NC
Division C

BAYVIEW LOAN SERVICING, LLC Plaintiff, vs. KENNETH J. NELSON A/K/A KENNETH NELSON, VIRGINIA J. NELSON A/K/A VIRGINIA NELSON, CITICORP TRUST BANK, FSB, AND UNKNOWN TENANTS/OWNERS, Defendants.

Notice is hereby given, pursuant to Final Judgment of Foreclosure for Plaintiff entered in this cause on May 8, 2014, in the Circuit Court of Sarasota County, Florida, The Clerk of the Court will sell the property situated in Sarasota County, Florida described as:

LOT 18, BLOCK 106, OF 7TH ADDITION TO PORT CHARLOTTE SUBDIVISION, ACCORDING TO THE PLAT THEREOF, AS RECORDED IN PLAT BOOK 12, PAGES 19, 19A THROUGH 19N, IN THE PUBLIC RECORDS OF SARASOTA COUNTY, FLORIDA.

and commonly known as: 3834 SOUTH CHAMBERLAIN BLVD, NORTH PORT, FL 34286; including the building, appurtenances, and fixtures located therein, at public sale, to the highest and best bidder, for cash, Sales are held online at: https://www.sarasota.realforeclose.com, on June 12, 2014 at 9:00 A.M..

Any persons claiming an interest in the surplus from the sale, if any, other than the property owner as of the date of the lis pendens must file a claim within 60 days after the sale.

If you are a person with a disability who needs any accommodation in order to participate in this proceeding, you are entitled, at no cost to you, to the provision of certain assistance. Please contact the Sarasota County Jury Office, P.O. Box 3079, Sarasota, Florida 34230-3079, (941)861-7400, at least seven (7) days before your scheduled court appearance, or immediately upon receiving this notification if the time before the scheduled appearance is less than seven (7) days; if you are hearing or voice impaired, call 711.

Karen E. Rushing
By: Frances Grace Cooper, Esquire
Attorney for Plaintiff
Edward B. Pritchard
(813) 229-0900 x1309
Kass Shuler, P.A.
P.O. Box 800
Tampa, FL 33601-0800
ForeclosureService@kasslaw.com
200850/1444377/
May 23, 30, 2014 14-02300S

SECOND INSERTION

NOTICE OF FORECLOSURE SALE IN THE CIRCUIT COURT OF THE TWELFTH JUDICIAL CIRCUIT IN AND FOR SARASOTA COUNTY, FLORIDA

CIVIL ACTION
CASE NO.: 2013 CA 007405 NC
DIVISION: C

WELLS FARGO BANK, NA, Plaintiff, vs. KENNETH D. DOERR A/K/A KENNETH DOERR, et al, Defendant(s).

NOTICE IS HEREBY GIVEN pursuant to a Final Judgment of Mortgage Foreclosure dated May 12, 2014 and entered in Case No. 2013 CA 007405 NC of the Circuit Court of the TWELFTH Judicial Circuit in and for SARASOTA County, Florida wherein WELLS FARGO BANK, NA is the Plaintiff and KENNETH D. DOERR A/K/A KENNETH DOERR; ANY AND ALL UNKNOWN PARTIES CLAIMING BY, THROUGH, UNDER, AND AGAINST THE HEREIN NAMED INDIVIDUAL DEFENDANT(S) WHO ARE NOT KNOWN TO BE DEAD OR ALIVE, WHETHER SAID UNKNOWN PARTIES MAY CLAIM AN INTEREST AS SPOUSES, HEIRS, DEVISEES, GRANTEEES, OR OTHER CLAIMANTS; OYSTER BAY ESTATES ASSOCIATION, INC.; are the Defendants, The Clerk will sell to the highest and best bidder for cash at WWW.SARASOTA.REALFORECLOSE.COM at 9:00AM, on the 18th day of June, 2014, the following described property as set forth in said Final Judgment:

LOT 27, BLOCK F, OYSTER BAY ESTATES, ACCORDING TO THE PLAT THEREOF, RECORDED IN PLAT BOOK 5, PAGES 79, 79A, 79B AND 79C OF THE PUBLIC RECORDS OF SARASOTA COUNTY, FLORIDA.

A/K/A 1641 FIELD ROAD, SARASOTA, FL 34231-2307

Any person claiming an interest in the surplus from the sale, if any, other than the property owner as of the date of the Lis Pendens must file a claim within sixty (60) days after the sale.

If you are a person with a disability who needs any accommodation in order to participate in this proceeding, you are entitled, at no cost to you, to the provision of certain assistance. Please contact the Sarasota County Jury Office, P.O. Box 3079, Sarasota, Florida 34230-3079, (941)861-7400, at least seven (7) days before your scheduled court appearance, or immediately upon receiving this notification if the time before the scheduled appearance is less than seven (7) days; if you are hearing or voice impaired, call 711.

By: Matthew Wolf
Florida Bar No. 92611
Ronald R Wolfe & Associates, P.L.
P.O. Box 25018
Tampa, Florida 33622-5018
(813) 251-4766
(813) 251-1541 Fax
F13014212
May 23, 30, 2014 14-02263S

SECOND INSERTION

NOTICE OF FORECLOSURE SALE IN THE CIRCUIT COURT OF THE 12TH JUDICIAL CIRCUIT, IN AND FOR SARASOTA COUNTY, FLORIDA

CIVIL DIVISION
CASE NO. 2013 CA 003180 NC
JPMORGAN CHASE BANK, NATIONAL ASSOCIATION Plaintiff, vs. LOUANNA M. O'NEILL A/K/A LOUANNA M. O'NEILL; et al; Defendants,

NOTICE IS HEREBY GIVEN pursuant to a Final Judgment of Foreclosure dated May 13, 2014, and entered in Case No. 2013 CA 003180 NC, of the Circuit Court of the 12th Judicial Circuit in and for SARASOTA County, Florida, wherein JPMORGAN CHASE BANK, NATIONAL ASSOCIATION is Plaintiff and LOUANNA M. O'NEILL A/K/A LOUANNA M. O'NEIL; LOUANNA M. O'NEILL A/K/A LOUANNA M. O'NEIL AS CO-TRUSTEE, UNDER TRUST AGREEMENT DATED JANUARY 11, 2010; UNKNOWN BENEFICIARIES OF THE TRUST AGREEMENT DATED JANUARY 11, 2010; UNKNOWN PERSON(S) IN POSSESSION OF THE SUBJECT PROPERTY; are defendants. The Clerk of Court will sell to the highest and best bidder for cash BY ELECTRONIC SALE AT: WWW.SARASOTA.REALFORECLOSE.COM, at 9:00 A.M., on the 18th day of June, 2014, the following described property as set forth in said Final Judgment, to wit:

LOTS 23 AND 24, BLOCK 28, VENICE EAST, 4TH ADDITION, AS PER PLAT THEREOF RECORDED IN PLAT BOOK 22, PAGE 9, PUBLIC RECORDS OF SARASOTA COUNTY, FLORIDA.

A person claiming an interest in the surplus from the sale, if any, other than the property owner as of the date of the lis pendens must file a claim within 60 days after the sale.

If you are a person with a disability who needs any accommodation in order to participate in this proceeding, you are entitled, at no cost to you, to the provision of certain assistance. Please contact the Sarasota County Jury Office, P.O. Box 3079, Sarasota, Florida 34230-3079, (941)861-7400, at least seven (7) days before your scheduled court appearance, or immediately upon receiving this notification if the time before the scheduled appearance is less than seven (7) days; if you are hearing or voice impaired, call 711.

Dated this 19th day of May, 2014.
Eric M. Knopp, Esq.
Bar No.: 709921
Submitted by:
Kahane & Associates, P.A.
8201 Peters Road, Ste.3000
Plantation, FL 33324
Telephone: (954) 382-3486
Telefacsimile: (954) 382-5380
Designated service email:
notice@kahaneandassociates.com
File No.: 13-01200 JPC
V1.20140101
May 23, 30, 2014 14-02299S

SECOND INSERTION

NOTICE OF FORECLOSURE SALE IN THE CIRCUIT COURT OF THE TWELFTH JUDICIAL CIRCUIT, IN AND FOR SARASOTA COUNTY, FLORIDA

CASE NO. 2010 CA 010213 NC BANK OF AMERICA, N.A., Plaintiff, vs. GLEN J. WHITNEY, et al. Defendants

NOTICE IS HEREBY GIVEN pursuant to a Final Judgment of Foreclosure dated April 23, 2014, and entered in Case No. 2010 CA 010213 NC, of the Circuit Court of the Twelfth Judicial Circuit in and for SARASOTA County, Florida. NATIONSTAR MORTGAGE LLC, is Plaintiff and GLEN J. WHITNEY; UNKNOWN SPOUSE OF GLEN J. WHITNEY; EILEEN E. WHITNEY A/K/A EE WHITNEY; UNKNOWN SPOUSE OF EILEEN E. WHITNEY A/K/A EE WHITNEY, are defendants. The Clerk of Court will sell to the highest and best bidder for cash via the Internet at www.sarasota.realforeclose.com, at 9:00 a.m., on the 23rd day of June, 2014, the following described property as set forth in said Final Judgment, to wit:

LOTS 6 AND 8, BLOCK 4, GOLF ESTATES, AS PER PLAT THEREOF RECORDED IN PLAT BOOK 2, PAGE 131, OF THE PUBLIC RECORDS OF SARASOTA COUNTY, FLORIDA. LESS THE WESTERN-MOST TWO FEET (2') OF LOTS 6 AND 8, BLOCK 4 OF GOLF ESTATES (WHICH DIRECTLY BORDER LOTS 5 AND 7, BLOCK 4 OF GOLF ESTATES), A SUBDIVISION IN SECTION 4, TOWNSHIP 37 SOUTH, RANGE 18 EAST AS RECORDED IN PLAT BOOK NO.2, PAGE 131, OF THE PUBLIC RECORDS

OF SARASOTA COUNTY, FLORIDA. TOGETHER WITH A PERPETUAL NON-EXCLUSIVE EASEMENT FOR INGRESS, EGRESS, ROAD PURPOSES, DRAINAGE AND UTILITY USE, OVER, UNDER, UPON AND ACROSS THE SOUTH 10 FEET OF LOT 3, BLOCK 4 AND THE NORTH 10 FEET OF LOT 5, BLOCK 4, GOLF ESTATES, AS RECORDED IN OFFICIAL RECORDS BOOK 1252, PAGE 1463 AND OFFICIAL RECORDS BOOK 1252, PAGE 1465, RESPECTIVELY, OF SAID RECORDS.

Any person claiming an interest in the surplus from the sale, if any, other than the property owner as of the date of the Lis Pendens must file a claim within 60 days after the sale.

If you are a person with a disability who needs any accommodation in order to participate in this proceeding, you are entitled, at no cost to you, to the provision of certain assistance. Please contact the Sarasota County Jury Office, P.O. Box 3079, Sarasota, Florida 34230-3079, (941)861-7400, at least seven (7) days before your scheduled court appearance, or immediately upon receiving this notification if the time before the scheduled appearance is less than seven (7) days; if you are hearing or voice impaired, call 711.

Mark C. Elia, Esq.
Florida Bar #: 695734
Email: MCElia@vanlawfl.com
VAN NESS LAW FIRM, PLC
1239 E. Newport Center Drive,
Suite 110
Deerfield Beach, Florida 33442
Ph: (954) 571-2031
Fax: (954) 571-2033
PRIMARY EMAIL:
Pleadings@vanlawfl.com
May 23, 30, 2014 14-02305S

SECOND INSERTION

NOTICE OF SALE IN THE CIRCUIT COURT OF THE TWELFTH JUDICIAL CIRCUIT IN AND FOR SARASOTA COUNTY, FLORIDA

CIVIL DIVISION
CASE NO. 2013 CA 001206 NC
C

BRANCH BANKING AND TRUST COMPANY, Plaintiff, v. FRANK DAMELIO A/K/A FRANK A. DAMELIO; UNKNOWN SPOUSE OF FRANK DAMELIO A/K/A FRANK A. DAMELIO; MYRIAM DAMELIO; UNKNOWN SPOUSE OF MYRIAM DAMELIO; PHILLIPPI HARBOR CLUB CONDOMINIUM ASSOCIATION, INC., ANY AND ALL UNKNOWN PARTIES CLAIMING BY, THROUGH, UNDER, AND AGAINST THE HEREIN NAMED INDIVIDUAL DEFENDANTS WHO ARE NOT KNOWN TO BE DEAD OR ALIVE, WHETHER SAID UNKNOWN PARTIES MAY CLAIM AN INTEREST AS SPOUSES, HEIRS, DEVISEES, GRANTEEES, OR OTHER CLAIMANTS; TENANT #1; TENANT #2, Defendants.

Notice is hereby given, pursuant to Final Judgment of Foreclosure for Plaintiff entered in this cause, in the Circuit Court of SARASOTA County, Florida, the Clerk of the Court will sell the property situated in SARASOTA County, Florida described as:

UNIT D2-38, PHILLIPPI HARBOR CLUB, A CONDOMINIUM, ACCORDING TO THE DECLARATION OF CONDOMINIUM AND CONDOMINIUM PLAT THEREOF RECORDED IN OFFICIAL RECORDS INSTRUMENT #2007026547, AND

AMENDMENTS THERETO, AND AS PER PLAT THEREOF, RECORDED IN CONDOMINIUM PLAT BOOK 40, PAGES 27-27G AND AMENDMENTS THERETO, OF THE PUBLIC RECORDS OF SARASOTA COUNTY, FLORIDA.

and commonly known as: 1780 Phillippi Harbor Drive #D2-38, Sarasota, FL 34231, at public sale, to the highest and best bidder, for cash, at www.sarasota.realforeclose.com, on JUNE 17, 2014 at 9:00 A.M.

ANY PERSON CLAIMING AN INTEREST IN THE SURPLUS FROM THE SALE, IF ANY, OTHER THAN THE PROPERTY OWNER AS OF THE DATE OF THE LIS PENDENS MUST FILE A CLAIM WITHIN 60 DAYS AFTER THE SALE.

If you are a person with a disability who needs any accommodation in order to participate in this proceeding, you are entitled, at no cost to you, to the provision of certain assistance. Please contact the Sarasota County Jury Office, P.O. Box 3079, Sarasota, Florida 34230-3079, (941)861-7400, at least seven (7) days before your scheduled court appearance, or immediately upon receiving this notification if the time before the scheduled appearance is less than seven (7) days; if you are hearing or voice impaired, call 711.

Dated this 5.19.14
Ross S. Felsher, Esq.,
FL Bar # 78169
ROBERT M. COPLEN, P.A.
10225 Ulmertown Road, Suite 5A
Largo, FL 33771
Telephone (727) 588-4550
Fax (727) 559-0887
Designated E-mail:
Foreclosure@coplenlaw.net
Attorney for Plaintiff
May 23, 30, 2014 14-02294S

SECOND INSERTION

NOTICE OF FORECLOSURE SALE IN THE CIRCUIT COURT OF THE 12TH JUDICIAL CIRCUIT, IN AND FOR SARASOTA COUNTY, FLORIDA

CIVIL DIVISION
CASE NO. 2013CA005313NC
BANKUNITED, N.A. Plaintiff, vs. ALAN REISINGER A/K/A ALAN J. REISINGER; DONNA REISINGER A/K/A DONNA J. REISINGER; et al; Defendants,

NOTICE IS HEREBY GIVEN pursuant to a Final Judgment of Foreclosure dated February 26, 2014, and entered in Case No. 2013CA005313NC, of the Circuit Court of the 12th Judicial Circuit in and for SARASOTA County, Florida, wherein BANKUNITED, N.A. is Plaintiff and ALAN REISINGER A/K/A ALAN J. REISINGER; DONNA REISINGER A/K/A DONNA J. REISINGER; UNKNOWN PERSON(S) IN POSSESSION OF THE SUBJECT PROPERTY; PIER 550 CONDOMINIUM ASSOCIATION, INC.; are defendants. The Clerk of Court will sell to the highest and best bidder for cash BY ELECTRONIC SALE AT: WWW.SARASOTA.REALFORECLOSE.COM, at 9:00 A.M., on the 26 day of June, 2014, the following described property as set forth in said Final Judgment, to wit:

UNIT 5, MONACO BUILDING, PIER 550, A CONDOMINIUM ACCORDING TO THE DECLARATION OF CONDOMINIUM THEREOF,

AS RECORDED IN OFFICIAL RECORDS BOOK 1245, PAGE 1521, AND AS PER PLAT THEREOF RECORDED IN CONDOMINIUM BOOK 11, PAGES 6, 6A AND 6B OF THE PUBLIC RECORDS OF SARASOTA COUNTY, FLORIDA.

A person claiming an interest in the surplus from the sale, if any, other than the property owner as of the date of the lis pendens must file a claim within 60 days after the sale.

If you are a person with a disability who needs any accommodation in order to participate in this proceeding, you are entitled, at no cost to you, to the provision of certain assistance. Please contact the Sarasota County Jury Office, P.O. Box 3079, Sarasota, Florida 34230-3079, (941)861-7400, at least seven (7) days before your scheduled court appearance, or immediately upon receiving this notification if the time before the scheduled appearance is less than seven (7) days; if you are hearing or voice impaired, call 711.

Dated this 20 day of May, 2014.
Eric M. Knopp, Esq.
Bar No.: 709921
Submitted by:
Kahane & Associates, P.A.
8201 Peters Road, Ste.3000
Plantation, FL 33324
Telephone: (954) 382-3486
Telefacsimile: (954) 382-5380
Designated service email:
notice@kahaneandassociates.com
File No.: 13-03346 BU
V1.20140101
May 23, 30, 2014 14-02323S

SECOND INSERTION

Year of Issuance: 2012
Tax Deed File #: 14-0062 TD

Description of Property: 0089130015 LOT 31 & E 10 FT LOT 32 BENEVA PARK

Name in which the property is assessed:
WINIFRED DEGREGORIO & JOSEPH DEGREGORIO JR
All of said property being in the County of Sarasota, State of Florida. Unless the certificate is redeemed according to law, the prop-

erty described in the certificate will be sold to the highest bidder at the Sarasota County Court House, 2000 Main Street, Historic Courtroom, East Wing, Sarasota, Florida, at 9:00 a.m. on the 24TH day of JUNE, 2014.

Karen E. Rushing
Clerk Of The Circuit Court
Sarasota County, Florida
By: T. Lake, Deputy Clerk
Publication Dates: MAY 23, 30; JUNE 6, 13, 2014
14-02279S

PUBLISH YOUR LEGAL NOTICES IN THE BUSINESS OBSERVER
(813) 221-9505 Hillsborough, Pasco
(727) 447-7784 Pinellas
(941) 906-9386 Manatee, Sarasota, Lee
(239) 263-0122 Collier
(941) 249-4900 Charlotte
(407) 654-5500 Orange

SECOND INSERTION

NOTICE OF APPLICATION FOR TAX DEED

Notice is hereby given that CITRUS CAPITAL LLC - SERIES 44 US BANK % CITRUS CAPITAL LLC -, the holder of the certificate listed below, has filed said certificate for a tax deed to be issued. The certificate number and year of issuance, the description of the property, and the names in which the property is assessed are as follows:

Certificate Number: 11068.000
Year of Issuance: 2012
Tax Deed File #: 14-0050 TD

Description of Property: 1152236503 LOT 3 BLK 2365 48TH ADD TO PORT CHARLOTTE
Name in which the property is assessed: EZEKIEL WALKER
All of said property being in the County of Sarasota, State of Florida. Unless the certificate is redeemed according to law, the property described in the certificate will be sold to the highest bidder at the Sarasota County Court House, 2000 Main Street, Historic Courtroom, East Wing, Sarasota, Florida, at 9:00 a.m. on the 24TH day of JUNE, 2014.

Karen E. Rushing
Clerk Of The Circuit Court
Sarasota County, Florida
By: T. Lake, Deputy Clerk
Publication Dates: MAY 23, 30; JUNE 6, 13, 2014

14-02268S

SECOND INSERTION

NOTICE OF APPLICATION FOR TAX DEED

Notice is hereby given that ERIKA GINSBERG KLEMMT, the holder of the certificate listed below, has filed said certificate for a tax deed to be issued. The certificate number and year of issuance, the description of the property, and the names in which the property is assessed are as follows:

Certificate Number: 11249.000
Year of Issuance: 2012
Tax Deed File #: 14-0056 TD

Description of Property: 2020020001 LOT 1, BLK F, AMARYLLIS PARK, CORR ORI 2007092044
Name in which the property is assessed: PARADISE OF SARASOTA INC
All of said property being in the County of Sarasota, State of Florida. Unless the certificate is redeemed according to law, the property described in the certificate will be sold to the highest bidder at the Sarasota County Court House, 2000 Main Street, Historic Courtroom, East Wing, Sarasota, Florida, at 9:00 a.m. on the 24TH day of JUNE, 2014.

Karen E. Rushing
Clerk Of The Circuit Court
Sarasota County, Florida
By: T. Lake, Deputy Clerk
Publication Dates: MAY 23, 30; JUNE 6, 13, 2014

14-02274S

SECOND INSERTION

NOTICE OF APPLICATION FOR TAX DEED

Notice is hereby given that PALM TREE TAX 2, LLC PALM TREE TAX LLC CAPITAL ONE, the holder of the certificate listed below, has filed said certificate for a tax deed to be issued. The certificate number and year of issuance, the description of the property, and the names in which the property is assessed are as follows:

Certificate Number: 1767.000
Year of Issuance: 2012
Tax Deed File #: 14-0063 TD

Description of Property: 0124021139 UNIT 23, BLDG 9, VINTAGE GRAND
Name in which the property is assessed: TRISHA SCHULHAUSER & KELLY SCHULHAUSER
All of said property being in the County of Sarasota, State of Florida. Unless the certificate is redeemed according to law, the property described in the certificate will be sold to the highest bidder at the Sarasota County Court House, 2000 Main Street, Historic Courtroom, East Wing, Sarasota, Florida, at 9:00 a.m. on the 24TH day of JUNE, 2014.

Karen E. Rushing
Clerk Of The Circuit Court
Sarasota County, Florida
By: T. Lake, Deputy Clerk
Publication Dates: MAY 23, 30; JUNE 6, 13, 2014

14-02280S

SECOND INSERTION

NOTICE OF APPLICATION FOR TAX DEED

Notice is hereby given that CITRUS CAPITAL LLC - SERIES 44 US BANK % CITRUS CAPITAL LLC, the holder of the certificate listed below, has filed said certificate for a tax deed to be issued. The certificate number and year of issuance, the description of the property, and the names in which the property is assessed are as follows:

Certificate Number: 11149.000
Year of Issuance: 2012
Tax Deed File #: 14-0051 TD

Description of Property: 2004150027 LOT 9 LESS N 3 FT & N 1/2 LOT 11 BLK A DE SOTO TERRACE
Name in which the property is assessed: MICHAEL D BURKART
All of said property being in the County of Sarasota, State of Florida. Unless the certificate is redeemed according to law, the property described in the certificate will be sold to the highest bidder at the Sarasota County Court House, 2000 Main Street, Historic Courtroom, East Wing, Sarasota, Florida, at 9:00 a.m. on the 24TH day of JUNE, 2014.

Karen E. Rushing
Clerk Of The Circuit Court
Sarasota County, Florida
By: T. Lake, Deputy Clerk
Publication Dates: MAY 23, 30; JUNE 6, 13, 2014

14-02269S

SECOND INSERTION

NOTICE OF APPLICATION FOR TAX DEED

Notice is hereby given that BORIS KIEVSKY, the holder of the certificate listed below, has filed said certificate for a tax deed to be issued. The certificate number and year of issuance, the description of the property, and the names in which the property is assessed are as follows:

Certificate Number: 7491.000
Year of Issuance: 2011
Tax Deed File #: 14-0057 TD

Description of Property: 0973171312 LOT 12 BLK 1713 36TH ADD TO PORT CHARLOTTE
Name in which the property is assessed: THOMAS W PERRY JR
All of said property being in the County of Sarasota, State of Florida. Unless the certificate is redeemed according to law, the property described in the certificate will be sold to the highest bidder at the Sarasota County Court House, 2000 Main Street, Historic Courtroom, East Wing, Sarasota, Florida, at 9:00 a.m. on the 24TH day of JUNE, 2014.

Karen E. Rushing
Clerk Of The Circuit Court
Sarasota County, Florida
By: T. Lake, Deputy Clerk
Publication Dates: MAY 23, 30; JUNE 6, 13, 2014

14-02275S

SECOND INSERTION

NOTICE OF APPLICATION FOR TAX DEED

Notice is hereby given that PALM TREE TAX 2, LLC PALM TREE TAX LLC CAPITAL ONE, the holder of the certificate listed below, has filed said certificate for a tax deed to be issued. The certificate number and year of issuance, the description of the property, and the names in which the property is assessed are as follows:

Certificate Number: 3315.000
Year of Issuance: 2012
Tax Deed File #: 14-0065 TD

Description of Property: 0461092009 UNIT S3-1 CIRCLE WOODS OF VENICE SEC 2
Name in which the property is assessed: JUANN A AUSTIN
All of said property being in the County of Sarasota, State of Florida. Unless the certificate is redeemed according to law, the property described in the certificate will be sold to the highest bidder at the Sarasota County Court House, 2000 Main Street, Historic Courtroom, East Wing, Sarasota, Florida, at 9:00 a.m. on the 24TH day of JUNE, 2014.

Karen E. Rushing
Clerk Of The Circuit Court
Sarasota County, Florida
By: T. Lake, Deputy Clerk
Publication Dates: MAY 23, 30; JUNE 6, 13, 2014

14-02281S

SECOND INSERTION

NOTICE OF APPLICATION FOR TAX DEED

Notice is hereby given that CITRUS CAPITAL LLC - SERIES 44 US BANK % CITRUS CAPITAL LLC -, the holder of the certificate listed below, has filed said certificate for a tax deed to be issued. The certificate number and year of issuance, the description of the property, and the names in which the property is assessed are as follows:

Certificate Number: 11307.000
Year of Issuance: 2012
Tax Deed File #: 14-0052 TD

Description of Property: 2020090097 LOT 18 BLK D NEWTOWN HEIGHTS
Name in which the property is assessed: SANDRA GRANT
All of said property being in the County of Sarasota, State of Florida. Unless the certificate is redeemed according to law, the property described in the certificate will be sold to the highest bidder at the Sarasota County Court House, 2000 Main Street, Historic Courtroom, East Wing, Sarasota, Florida, at 9:00 a.m. on the 24TH day of JUNE, 2014.

Karen E. Rushing
Clerk Of The Circuit Court
Sarasota County, Florida
By: T. Lake, Deputy Clerk
Publication Dates: MAY 23, 30; JUNE 6, 13, 2014

14-02270S

SECOND INSERTION

NOTICE OF APPLICATION FOR TAX DEED

Notice is hereby given that BORIS KIEVSKY, the holder of the certificate listed below, has filed said certificate for a tax deed to be issued. The certificate number and year of issuance, the description of the property, and the names in which the property is assessed are as follows:

Certificate Number: 7493.000
Year of Issuance: 2011
Tax Deed File #: 14-0058 TD

Description of Property: 0973171317 LOT 17 BLK 1713 36TH ADD TO PORT CHARLOTTE
Name in which the property is assessed: THOMAS W PERRY
All of said property being in the County of Sarasota, State of Florida. Unless the certificate is redeemed according to law, the property described in the certificate will be sold to the highest bidder at the Sarasota County Court House, 2000 Main Street, Historic Courtroom, East Wing, Sarasota, Florida, at 9:00 a.m. on the 24TH day of JUNE, 2014.

Karen E. Rushing
Clerk Of The Circuit Court
Sarasota County, Florida
By: T. Lake, Deputy Clerk
Publication Dates: MAY 23, 30; JUNE 6, 13, 2014

14-02276S

SECOND INSERTION

NOTICE OF APPLICATION FOR TAX DEED

Notice is hereby given that PALM TREE TAX 2, LLC PALM TREE TAX LLC CAPITAL ONE, the holder of the certificate listed below, has filed said certificate for a tax deed to be issued. The certificate number and year of issuance, the description of the property, and the names in which the property is assessed are as follows:

Certificate Number: 4454.000
Year of Issuance: 2012
Tax Deed File #: 14-0066 TD

Description of Property: 0791061118 LOT 118 LA CASA
Name in which the property is assessed: GEORGE F CHARETTE TTEE & GEORGE F CHARETTE EST & JOHN M CHARETTE PR
All of said property being in the County of Sarasota, State of Florida. Unless the certificate is redeemed according to law, the property described in the certificate will be sold to the highest bidder at the Sarasota County Court House, 2000 Main Street, Historic Courtroom, East Wing, Sarasota, Florida, at 9:00 a.m. on the 24TH day of JUNE, 2014.

Karen E. Rushing
Clerk Of The Circuit Court
Sarasota County, Florida
By: T. Lake, Deputy Clerk
Publication Dates: MAY 23, 30; JUNE 6, 13, 2014

14-02282S

SECOND INSERTION

NOTICE OF APPLICATION FOR TAX DEED

Notice is hereby given that CITRUS CAPITAL LLC - SERIES 44 US BANK % CITRUS CAPITAL LLC -, the holder of the certificate listed below, has filed said certificate for a tax deed to be issued. The certificate number and year of issuance, the description of the property, and the names in which the property is assessed are as follows:

Certificate Number: 11740.000
Year of Issuance: 2012
Tax Deed File #: 14-0053 TD

Description of Property: 2027102003 UNIT 3, VILLAS ON LAUREL THE
Name in which the property is assessed: LHR VENTURES LLC
All of said property being in the County of Sarasota, State of Florida. Unless the certificate is redeemed according to law, the property described in the certificate will be sold to the highest bidder at the Sarasota County Court House, 2000 Main Street, Historic Courtroom, East Wing, Sarasota, Florida, at 9:00 a.m. on the 24TH day of JUNE, 2014.

Karen E. Rushing
Clerk Of The Circuit Court
Sarasota County, Florida
By: T. Lake, Deputy Clerk
Publication Dates: MAY 23, 30; JUNE 6, 13, 2014

14-02271S

SECOND INSERTION

NOTICE OF APPLICATION FOR TAX DEED

Notice is hereby given that BORIS KIEVSKY, the holder of the certificate listed below, has filed said certificate for a tax deed to be issued. The certificate number and year of issuance, the description of the property, and the names in which the property is assessed are as follows:

Certificate Number: 11236.000
Year of Issuance: 2011
Tax Deed File #: 14-0059 TD

Description of Property: 1142259624 LOT 24 BLK 2596 51ST ADD TO PORT CHARLOTTE
Name in which the property is assessed: SARASOTA INVESTMENT TRUST
All of said property being in the County of Sarasota, State of Florida. Unless the certificate is redeemed according to law, the property described in the certificate will be sold to the highest bidder at the Sarasota County Court House, 2000 Main Street, Historic Courtroom, East Wing, Sarasota, Florida, at 9:00 a.m. on the 24TH day of JUNE, 2014.

Karen E. Rushing
Clerk Of The Circuit Court
Sarasota County, Florida
By: T. Lake, Deputy Clerk
Publication Dates: MAY 23, 30; JUNE 6, 13, 2014

14-02277S

SECOND INSERTION

NOTICE OF APPLICATION FOR TAX DEED

Notice is hereby given that PALM TREE TAX 2, LLC PALM TREE TAX LLC CAPITAL ONE, the holder of the certificate listed below, has filed said certificate for a tax deed to be issued. The certificate number and year of issuance, the description of the property, and the names in which the property is assessed are as follows:

Certificate Number: 4455.000
Year of Issuance: 2012
Tax Deed File #: 14-0067 TD

Description of Property: 0791061130 LOT 130 LA CASA
Name in which the property is assessed: GEORGE H HILL III & VIRDAY H MC CULLEY
All of said property being in the County of Sarasota, State of Florida. Unless the certificate is redeemed according to law, the property described in the certificate will be sold to the highest bidder at the Sarasota County Court House, 2000 Main Street, Historic Courtroom, East Wing, Sarasota, Florida, at 9:00 a.m. on the 24TH day of JUNE, 2014.

Karen E. Rushing
Clerk Of The Circuit Court
Sarasota County, Florida
By: T. Lake, Deputy Clerk
Publication Dates: MAY 23, 30; JUNE 6, 13, 2014

14-02283S

SECOND INSERTION

NOTICE OF APPLICATION FOR TAX DEED

Notice is hereby given that ERIKA GINSBERG KLEMMT, the holder of the certificate listed below, has filed said certificate for a tax deed to be issued. The certificate number and year of issuance, the description of the property, and the names in which the property is assessed are as follows:

Certificate Number: 1156.000
Year of Issuance: 2012
Tax Deed File #: 14-0054 TD

Description of Property: 0079090002 LOTS 22 THRU 32, BLK 4, SIESTA BEACH, LESS THAT PORTION COMPRISING SUBMERGED LANDS IN ROBERTS BAY
Name in which the property is assessed: CL SIESTA INC

All of said property being in the County of Sarasota, State of Florida. Unless the certificate is redeemed according to law, the property described in the certificate will be sold to the highest bidder at the Sarasota County Court House, 2000 Main Street, Historic Courtroom, East Wing, Sarasota, Florida, at 9:00 a.m. on the 24TH day of JUNE, 2014.

Karen E. Rushing
Clerk Of The Circuit Court
Sarasota County, Florida
By: T. Lake, Deputy Clerk
Publication Dates: MAY 23, 30; JUNE 6, 13, 2014

14-02272S

SECOND INSERTION

NOTICE OF APPLICATION FOR TAX DEED

Notice is hereby given that BORIS KIEVSKY, the holder of the certificate listed below, has filed said certificate for a tax deed to be issued. The certificate number and year of issuance, the description of the property, and the names in which the property is assessed are as follows:

Certificate Number: 11237.000
Year of Issuance: 2011
Tax Deed File #: 14-0060 TD

Description of Property: 1142259625 LOT 25 BLK 2596 51ST ADD TO PORT CHARLOTTE
Name in which the property is assessed: SARASOTA INVESTMENT TRUST
All of said property being in the County of Sarasota, State of Florida. Unless the certificate is redeemed according to law, the property described in the certificate will be sold to the highest bidder at the Sarasota County Court House, 2000 Main Street, Historic Courtroom, East Wing, Sarasota, Florida, at 9:00 a.m. on the 24TH day of JUNE, 2014.

Karen E. Rushing
Clerk Of The Circuit Court
Sarasota County, Florida
By: T. Lake, Deputy Clerk
Publication Dates: MAY 23, 30; JUNE 6, 13, 2014

14-02278S

SECOND INSERTION

NOTICE OF APPLICATION FOR TAX DEED

Notice is hereby given that PALM TREE TAX 2, LLC PALM TREE TAX LLC CAPITAL ONE, the holder of the certificate listed below, has filed said certificate for a tax deed to be issued. The certificate number and year of issuance, the description of the property, and the names in which the property is assessed are as follows:

Certificate Number: 4462.000
Year of Issuance: 2012
Tax Deed File #: 14-0068 TD

Description of Property: 0791061587 LOT 587 LA CASA
Name in which the property is assessed: CAROL L KORTJOHN & OLIVER H KORTJOHN
All of said property being in the County of Sarasota, State of Florida. Unless the certificate is redeemed according to law, the property described in the certificate will be sold to the highest bidder at the Sarasota County Court House, 2000 Main Street, Historic Courtroom, East Wing, Sarasota, Florida, at 9:00 a.m. on the 24TH day of JUNE, 2014.

Karen E. Rushing
Clerk Of The Circuit Court
Sarasota County, Florida
By: T. Lake, Deputy Clerk
Publication Dates: MAY 23, 30; JUNE 6, 13, 2014

14-02284S

SECOND INSERTION

NOTICE OF APPLICATION FOR TAX DEED

Notice is hereby given that ERIKA GINSBERG KLEMMT, the holder of the certificate listed below, has filed said certificate for a tax deed to be issued. The certificate number and year of issuance, the description of the property, and the names in which the property is assessed are as follows:

Certificate Number: 11111.000
Year of Issuance: 2012
Tax Deed File #: 14-0055 TD

Description of Property: 2002010002 BEG AT SW COR OF LOT 10 BLK 5 TH S ALG EXT IN A SLY DIR OF W LINE OF LOT 10 TO S SIDE OF EDWARDS DR FOR POB TH CONT S IN SAME DIR 39.5 FT M/L TO THE WATERS OF LAKE UPLAND TH CONT IN SAME DIR 67.5 FT M/L TH ELY 118.5 FT M/L TH NLY 126.5 FT M/L TO S SIDE OF EDWARDS DR TH WLY ALG S LINE OF EDWARDS DR TO POB THE UPLANDS
Name in which the property is assessed: FRANCES E BAILEY

All of said property being in the County of Sarasota, State of Florida. Unless the certificate is redeemed according to law, the property described in the certificate will be sold to the highest bidder at the Sarasota County Court House, 2000 Main Street, Historic Courtroom, East Wing, Sarasota, Florida, at 9:00 a.m. on the 24TH day of JUNE, 2014.

Karen E. Rushing
Clerk Of The Circuit Court
Sarasota County, Florida
By: T. Lake, Deputy Clerk
Publication Dates: MAY 23, 30; JUNE 6, 13, 2014

14-02273S

SECOND INSERTION

NOTICE OF SALE AND ACTION FOR PUBLICATION

IN THE CIRCUIT COURT OF THE TWELFTH JUDICIAL CIRCUIT IN AND FOR SARASOTA COUNTY, FLORIDA

CIVIL DIVISION
Case No. 2012 CA 001763 NC
JAMES RINI & DAVE DAVIS, Plaintiff, v.
LARRY FRANK MATTACCHIONE, SR. & SHIRLEY MATTACCHIONE Defendants.

YOU ARE NOTIFIED that pursuant to a Order Granting Plaintiff's Motion to Set Sale entered in the above styled cause, in the Circuit Court of SARASOTA County, Florida, I will sell the property situate in SARASOTA County, Florida described as:

Lots 16-17 Blk H Palm Grove PB 1/69, according to the map or plat thereof as recorded in Plat Book, Public Records of Sarasota County, Florida

at public sale, to the highest bidder or bidders for cash on www.sarasota.realforeclose.com on June 20, 2014 at 9:00 a.m.

If you are a person with a disability who needs any accommodation in order to participate in this proceeding, you are entitled, at no cost to you, to the provision of certain assistance. Please contact the Sarasota County Jury Office, P.O. Box 3079, Sarasota, Florida 34230-3079, (941)861-7400, at least seven (7) days before your scheduled court appearance, or immediately upon receiving this notification if the time before the scheduled appearance is less than seven (7) days; if you are hearing or voice impaired, call 711. Galewski Law Group, P.A.

1112 E. Kennedy Blvd.
Tampa, FL 33602
Telephone 813.222.8210
Facsimile 813.222.8211
Website www.galewski.com
May 23, 30, 2014 14-02322S

SECOND INSERTION

Decedent's name: Chester S. Mazur
The file number of the estate: 2014-CP-000832
The designation and address of the court in which the proceedings are pending: Circuit Court, Sarasota County, Probate Division.
The personal representative's name and address: Chester M. Mazur, 7283 East Quaker Street, Orchard Park, NY 14127.
The name and address of the personal representative's attorney: Edward A. Pace, Esq., 4513 S. Buffalo, Street, Orchard Park, NY 14127
May 23, 30, 2014 14-02328S

Dated this 20 day of May, 2014.

By: Jennifer Nicole Tarquinio Bar #99192

Choice Legal Group, P.A.
P.O. Box 9908
Fort Lauderdale, FL 33310-9908
Telephone: (954) 453-0365
Facsimile: (954) 771-6052
Toll Free: 1-800-441-2438
DESIGNATED PRIMARY E-MAIL FOR SERVICE PURSUANT TO FLA R. JUD. ADMIN 2.516
eservice@clelegalgroup.com
12-07902
May 23, 30, 2014 14-02321S

SECOND INSERTION

RE-NOTICE OF FORECLOSURE SALE IN THE CIRCUIT COURT OF THE 12TH JUDICIAL CIRCUIT, IN AND FOR SARASOTA COUNTY, FLORIDA
CIVIL DIVISION:
CASE NO.: 2012 CA 010412 NC
ACHIEVA CREDIT UNION FORMERLY KNOWN AS SARASOTA COASTAL CREDIT UNION,
Plaintiff, vs.
MARY K. MOBLEY; ACHIEVA CREDIT UNION FORMERLY

KNOWN AS SARASOTA COASTAL CREDIT UNION; GROVE POINTE HOMEOWNERS ASSOCIATION, INC.; REICHARD S. MOBLEY, SR.; UNKNOWN TENANT IN POSSESSION OF THE SUBJECT PROPERTY,
Defendants.
NOTICE IS HEREBY GIVEN pursuant to an Order Resetting Foreclosure Sale dated the 7th day of May, 2014, and entered in Case No. 2012 CA 010412 NC, of the Circuit Court of the 12TH Judicial Circuit in and for Sarasota County, Florida, wherein ACHIEVA CREDIT

UNION FORMERLY KNOWN AS SARASOTA COASTAL CREDIT UNION is the Plaintiff and MARY K. MOBLEY; ACHIEVA CREDIT UNION FORMERLY KNOWN AS SARASOTA COASTAL CREDIT UNION; GROVE POINTE HOMEOWNERS ASSOCIATION, INC.; REICHARD S. MOBLEY, SR. and UNKNOWN TENANT (S) IN POSSESSION OF THE SUBJECT PROPERTY are defendants. The Clerk of this Court shall sell to the highest and best bidder for cash electronically at www.sarasota.realforeclose.com at 9:00 AM on the 17th day of June, 2014,

the following described property as set forth in said Final Judgment, to wit: LOT 281, GROVE POINTE, UNIT 1, ACCORDING TO THE PLAT THEREOF, RECORDED IN PLAT BOOK 34, PAGE 1, OF THE PUBLIC RECORDS OF SARASOTA COUNTY, FLORIDA
ANY PERSON CLAIMING AN INTEREST IN THE SURPLUS FROM THE SALE, IF ANY, OTHER THAN THE PROPERTY OWNER AS OF THE DATE OF THE LIS PENDENS MUST FILE A CLAIM WITHIN 60 DAYS AFTER THE SALE.

If you are a person with a disability who needs any accommodation in order to participate in this proceeding, you are entitled, at no cost to you, to the provision of certain assistance. Please contact the Sarasota County Jury Office, P.O. Box 3079, Sarasota, Florida 34230-3079, (941)861-7400, at least seven (7) days before your scheduled court appearance, or immediately upon receiving this notification if the time before the scheduled appearance is less than seven (7) days; if you are hearing or voice impaired, call 711.

SECOND INSERTION

RE-NOTICE OF FORECLOSURE SALE IN THE CIRCUIT COURT OF THE TWELFTH JUDICIAL CIRCUIT, IN AND FOR SARASOTA COUNTY, FLORIDA... CIVIL DIVISION... CASE NO.: 2009 CA 000767 NC PNC BANK, NATIONAL ASSOCIATION, SUCCESSOR BY MERGER TO NATIONAL CITY MORTGAGE, A DIVISION OF NATIONAL CITY BANK, SUCCESSOR BY MERGER TO NATIONAL CITY BANK OF

INDIANA Plaintiff, vs. HOLLY A. REX, et al Defendants. RE-NOTICE IS HEREBY GIVEN pursuant to an Order Granting Plaintiff's Motion to Reschedule Foreclosure Sale filed May 9, 2014 and entered in Case No. 2009 CA 000767 NC of the Circuit Court of the TWELFTH Judicial Circuit in and for SARASOTA COUNTY, Florida, wherein PNC BANK, NATIONAL ASSOCIATION, SUCCESSOR BY MERGER TO NATIONAL CITY

MORTGAGE, A DIVISION OF NATIONAL CITY BANK, SUCCESSOR BY MERGER TO NATIONAL CITY BANK OF INDIANA, is Plaintiff, and HOLLY A. REX, et al are Defendants, the clerk will sell to the highest and best bidder for cash, beginning at 09:00 AM at www.sarasota.realforeclose.com, in accordance with Chapter 45, Florida Statutes, on the 13 day of June, 2014, the following described property as set forth in said Lis Pendens, to wit: Lot 1, Block 1517, 30th ADDI-

TION TO PORT CHARLOTTE SUBDIVISION, according to the Plat thereof recorded in Plat Book 15 Pages 14, 14A thru 14Q of the Public Records of Sarasota County, Florida. Any person claiming an interest in the surplus funds from the sale, if any, other than the property owner as of the date of the lis pendens must file a claim within 60 days after the sale. If you are a person with a disability who needs any accommodation in order to participate in

this proceeding, you are entitled, at no cost to you, to the provision of certain assistance. Please contact the Sarasota County Jury Office, P.O. Box 3079, Sarasota, Florida 34230-3079, (941)861-7400, at least seven (7) days before your scheduled court appearance, or immediately upon receiving this notification if the time before the scheduled appearance is less than seven (7) days; if you are hearing or voice impaired, call 711. Dated: May 20, 2014 By: /s/ Heather J. Koch

Phelan Hallinan, PLC Heather J. Koch, Esq., Florida Bar No. 89107 Emilio R. Lenzi, Esq., Florida Bar No. 0668273 Phelan Hallinan, PLC Attorneys for Plaintiff 2727 West Cypress Creek Road Ft. Lauderdale, FL 33309 Tel: 954-462-7000 Fax: 954-462-7001 Service by email: FL.Service@PhelanHallinan.com PH # 46434 May 23, 30, 2014 14-02332S

SECOND INSERTION

RE-NOTICE OF FORECLOSURE SALE IN THE CIRCUIT COURT OF THE TWELFTH JUDICIAL CIRCUIT, IN AND FOR SARASOTA COUNTY, FLORIDA... CIVIL DIVISION... CASE NO.: 2013 CA 003045 NC JPMORGAN CHASE BANK, NATIONAL ASSOCIATION Plaintiff, vs. JEREMIAH GAERTNER, et al Defendants.

NOTICE OF FORECLOSURE SALE IN THE CIRCUIT COURT OF THE TWELFTH JUDICIAL CIRCUIT IN AND FOR SARASOTA COUNTY, FLORIDA CIVIL ACTION... CASE NO.: 58-2009-CA-020713 NC DIVISION: C WELLS FARGO BANK, NA, Plaintiff, vs. STEPHEN A. PALMER, et al, Defendant(s).

NOTICE OF FORECLOSURE SALE IN THE CIRCUIT COURT OF THE TWELFTH JUDICIAL CIRCUIT IN AND FOR SARASOTA COUNTY, FLORIDA CIVIL ACTION... CASE NO.: 58-2013-CA-008133 NC DIVISION: C JPMORGAN CHASE BANK, NATIONAL ASSOCIATION, Plaintiff, vs. EDWARD M. GRADY, JR., et al, Defendant(s).

NOTICE OF SALE IN THE CIRCUIT CIVIL COURT OF THE TWELFTH JUDICIAL CIRCUIT OF FLORIDA, IN AND FOR SARASOTA COUNTY CIVIL DIVISION... Case No. 58-2013-CA-004611-NC Division A JPMC SPECIALTY MORTGAGE LLC F/K/A WM SPECIALTY MORTGAGE LLC Plaintiff, vs. THOMAS E. RUGGIERI, PATRICIA L. RUGGIERI, ACCUTECH RESTORATION & REMODELING, INC, AND UNKNOWN TENANTS/OWNERS, Defendants.

NOTICE OF FORECLOSURE SALE IN THE CIRCUIT COURT OF THE TWELFTH JUDICIAL CIRCUIT IN AND FOR SARASOTA COUNTY, FLORIDA CIVIL ACTION... CASE NO.: 2013 CA 008269 NC DIVISION: A WELLS FARGO BANK, N.A., Plaintiff, vs. KEITH M. CUMMINGS, et al, Defendant(s).

NOTICE OF SALE IN THE CIRCUIT CIVIL COURT OF THE TWELFTH JUDICIAL CIRCUIT OF FLORIDA, IN AND FOR SARASOTA COUNTY CIVIL DIVISION... Case No. 58-2013-CA-001693 NC Division A U.S. BANK NATIONAL ASSOCIATION, AS TRUSTEE FOR HOMEBANC MORTGAGE TRUST 2005-3 MORTGAGE BACKED NOTES, SERIES 2005-3 Plaintiff, vs. CHARLES T. BRADEN AND UNKNOWN TENANTS/OWNERS, Defendants.

RE-NOTICE IS HEREBY GIVEN pursuant to an Order Granting Plaintiff's Motion to Reschedule Foreclosure Sale filed May 16, 2014 and entered in Case No. 2013 CA 003045 NC of the Circuit Court of the TWELFTH Judicial Circuit in and for SARASOTA COUNTY, Florida, wherein JPMORGAN CHASE BANK, NATIONAL ASSOCIATION, is Plaintiff, and JEREMIAH GAERTNER, et al are Defendants, the clerk will sell to the highest and best bidder for cash, beginning at 09:00 AM at www.sarasota.realforeclose.com, in accordance with Chapter 45, Florida Statutes, on the 20 day of June, 2014, the following described property as set forth in said Lis Pendens, to wit: THE SOUTH 32.5 FEET OF THE WEST 90 FEET OF LOT 25 AND THE WEST 90 FEET OF LOTS 27 AND 29, BLOCK 5, FLORA VILLA SUBDIVISION, AS PER PLAT THEREOF RECORDED IN PLAT BOOK 2, PAGE 5, OF THE PUBLIC RECORDS OF SARASOTA COUNTY, FLORIDA.

NOTICE IS HEREBY GIVEN pursuant to a Final Judgment of Mortgage Foreclosure dated April 21, 2014 and entered in Case No. 58-2009-CA-020713 NC of the Circuit Court of the TWELFTH Judicial Circuit in and for SARASOTA County, Florida wherein WELLS FARGO BANK, NA is the Plaintiff and STEPHEN A PALMER; DONALD H PADGETT; JOAN B. PADGETT A/K/A JO ANN B. PADGETT; CEDAR HAMMOCK OWNERS' ASSOCIATION, INC.; UNITED STATES OF AMERICA; are the Defendants, The Clerk will sell to the highest and best bidder for cash at WWW.SARASOTA.REALFORECLOSE.COM at 9:00AM, on the 18th day of September, 2014, the following described property as set forth in said Final Judgment:

NOTICE IS HEREBY GIVEN pursuant to a Final Judgment of Mortgage Foreclosure dated May 12, 2014 and entered in Case No. 58-2013-CA-008133 NC of the Circuit Court of the TWELFTH Judicial Circuit in and for SARASOTA County, Florida wherein JPMORGAN CHASE BANK, NATIONAL ASSOCIATION is the Plaintiff and EDWARD M. GRADY, JR.; THE UNKNOWN SPOUSE OF EDWARD M. GRADY, JR. N/K/A AMY BRYAN; JOCKEY CLUB OF NORTH PORT PROPERTY OWNERS' ASSOCIATION, INC.; are the Defendants, The Clerk will sell to the highest and best bidder for cash at WWW.SARASOTA.REALFORECLOSE.COM at 9:00AM, on the 9th day of September, 2014, the following described property as set forth in said Final Judgment:

Notice is hereby given, pursuant to Final Judgment of Foreclosure for Plaintiff entered in this cause on May 12, 2014, in the Circuit Court of Sarasota County, Florida, The Clerk of the Court will sell the property situated in Sarasota County, Florida described as: LOT 4, BLOCK 1750, 34TH ADDITION TO PORT CHARLOTTE SUBDIVISION, ACCORDING TO THE PLAT THEREOF RECORDED IN PLAT BOOK 15, PAGE 18, OF THE PUBLIC RECORDS OF SARASOTA COUNTY, FLORIDA.

NOTICE IS HEREBY GIVEN pursuant to a Final Judgment of Mortgage Foreclosure dated May 12, 2014 and entered in Case No. 2013 CA 008269 NC of the Circuit Court of the TWELFTH Judicial Circuit in and for SARASOTA County, Florida wherein WELLS FARGO BANK, N.A. is the Plaintiff and KEITH M. CUMMINGS; SANDRA J. CUMMINGS; UNITED STATES OF AMERICA-INTERNAL REVENUE SERVICE; are the Defendants, The Clerk will sell to the highest and best bidder for cash at WWW.SARASOTA.REALFORECLOSE.COM at 9:00AM, on the 17th day of June, 2014, the following described property as set forth in said Final Judgment: LOT 16, BLOCK 501, ELEVENTH ADDITION TO PORT CHARLOTTE SUBDIVISION, ACCORDING TO THE PLAT THEREOF, AS RECORDED IN PLAT BOOK 13, PAGE 2 AND 2A THROUGH 2I, OF THE PUBLIC RECORDS OF SARASOTA COUNTY, FLORIDA.

Notice is hereby given, pursuant to Final Judgment of Foreclosure for Plaintiff entered in this cause on May 12, 2014, in the Circuit Court of Sarasota County, Florida, The Clerk of the Court will sell the property situated in Sarasota County, Florida described as: LOT 29, BLOSSOM BROOK, ACCORDING TO THE PLAT THEREOF RECORDED IN PLAT BOOK 9, PAGE 20, OF THE PUBLIC RECORDS OF SARASOTA COUNTY, FLORIDA.

and commonly known as: 2238 GROVE ST, SARASOTA, FL 34239; including the building, appurtenances, and fixtures located therein, at public sale, to the highest and best bidder, for cash, Sales are held online at: https://www.sarasota.realforeclose.com, on June 16, 2014 at 9:00 A.M..

THE NORTHERLY 37.40 FEET OF LOT 6, BLOCK C, CEDAR HAMMOCK, A SUBDIVISION ACCORDING TO THE PLAT THEREOF, AS RECORDED IN PLAT BOOK 28, PAGES 21-21D, OF THE PUBLIC RECORDS OF SARASOTA COUNTY, FLORIDA.

LOT 12, BLOCK 2632, FIFTY-SECOND ADDITION TO PORT CHARLOTTE SUBDIVISION, A SUBDIVISION ACCORDING TO THE PLAT THEREOF, AS RECORDED IN PLAT BOOK 21, PAGE 13, 13A-13NN, OF THE PUBLIC RECORDS OF SARASOTA COUNTY, FLORIDA.

and commonly known as: 3362 FERGUS STREET, NORTH PORT, FL 34288; including the building, appurtenances, and fixtures located therein, at public sale, to the highest and best bidder, for cash, Sales are held online at: https://www.sarasota.realforeclose.com, on June 16, 2014 at 9:00 A.M..

A/K/A 3619 COQUINA AVENUE, NORTH PORT, FL 34286-7436

Any person claiming an interest in the surplus from the sale, if any, other than the property owner as of the date of the lis pendens must file a claim within 60 days after the sale.

Any person claiming an interest in the surplus funds from the sale, if any, other than the property owner as of the date of the lis pendens must file a claim within 60 days after the sale.

A/K/A 5191 CEDAR HAMMOCK LANE, SARASOTA, FL 34232

A/K/A 6857 KETONA ROAD, NORTHPORT, FL 34287

Any person claiming an interest in the surplus from the sale, if any, other than the property owner as of the date of the lis pendens must file a claim within 60 days after the sale.

Any person claiming an interest in the surplus from the sale, if any, other than the property owner as of the date of the lis pendens must file a claim within sixty (60) days after the sale.

Any person claiming an interest in the surplus from the sale, if any, other than the property owner as of the date of the lis pendens must file a claim within 60 days after the sale.

If you are a person with a disability who needs any accommodation in order to participate in this proceeding, you are entitled, at no cost to you, to the provision of certain assistance. Please contact the Sarasota County Jury Office, P.O. Box 3079, Sarasota, Florida 34230-3079, (941)861-7400, at least seven (7) days before your scheduled court appearance, or immediately upon receiving this notification if the time before the scheduled appearance is less than seven (7) days; if you are hearing or voice impaired, call 711.

Any person claiming an interest in the surplus from the sale, if any, other than the property owner as of the date of the Lis Pendens must file a claim within sixty (60) days after the sale.

Any person claiming an interest in the surplus from the sale, if any, other than the property owner as of the date of the Lis Pendens must file a claim within sixty (60) days after the sale.

If you are a person with a disability who needs any accommodation in order to participate in this proceeding, you are entitled, at no cost to you, to the provision of certain assistance. Please contact the Sarasota County Jury Office, P.O. Box 3079, Sarasota, Florida 34230-3079, (941)861-7400, at least seven (7) days before your scheduled court appearance, or immediately upon receiving this notification if the time before the scheduled appearance is less than seven (7) days; if you are hearing or voice impaired, call 711.

If you are a person with a disability who needs any accommodation in order to participate in this proceeding, you are entitled, at no cost to you, to the provision of certain assistance. Please contact the Sarasota County Jury Office, P.O. Box 3079, Sarasota, Florida 34230-3079, (941)861-7400, at least seven (7) days before your scheduled court appearance, or immediately upon receiving this notification if the time before the scheduled appearance is less than seven (7) days; if you are hearing or voice impaired, call 711.

If you are a person with a disability who needs any accommodation in order to participate in this proceeding, you are entitled, at no cost to you, to the provision of certain assistance. Please contact the Sarasota County Jury Office, P.O. Box 3079, Sarasota, Florida 34230-3079, (941)861-7400, at least seven (7) days before your scheduled court appearance, or immediately upon receiving this notification if the time before the scheduled appearance is less than seven (7) days; if you are hearing or voice impaired, call 711.

Dated: May 20, 2014 By: /s/ Heather J. Koch Phelan Hallinan, PLC Heather J. Koch, Esq., Florida Bar No. 89107 Emilio R. Lenzi, Esq., Florida Bar No. 0668273 Phelan Hallinan, PLC Attorneys for Plaintiff 2727 West Cypress Creek Road Ft. Lauderdale, FL 33309 Tel: 954-462-7000 Fax: 954-462-7001 Service by email: FL.Service@PhelanHallinan.com PH # 39417 May 23, 30, 2014 14-02331S

If you are a person with a disability who needs any accommodation in order to participate in this proceeding, you are entitled, at no cost to you, to the provision of certain assistance. Please contact the Sarasota County Jury Office, P.O. Box 3079, Sarasota, Florida 34230-3079, (941)861-7400, at least seven (7) days before your scheduled court appearance, or immediately upon receiving this notification if the time before the scheduled appearance is less than seven (7) days; if you are hearing or voice impaired, call 711.

If you are a person with a disability who needs any accommodation in order to participate in this proceeding, you are entitled, at no cost to you, to the provision of certain assistance. Please contact the Sarasota County Jury Office, P.O. Box 3079, Sarasota, Florida 34230-3079, (941)861-7400, at least seven (7) days before your scheduled court appearance, or immediately upon receiving this notification if the time before the scheduled appearance is less than seven (7) days; if you are hearing or voice impaired, call 711.

Karen E. Rushing By: Frances Grace Cooper, Esquire Attorney for Plaintiff

By: Matthew Wolf Florida Bar No. 92611 Ronald R Wolfe & Associates, P.L. P.O. Box 25018 Tampa, Florida 33622-5018 (813) 251-4766 (813) 251-1541 Fax F13011858 May 23, 30, 2014 14-02245S

Karen E. Rushing By: Frances Grace Cooper, Esquire Attorney for Plaintiff Edward B. Pritchard (813) 229-0900 x1309 Kass Shuler, P.A. P.O. Box 800 Tampa, FL 33601-0800 ForeclosureService@kasslaw.com 320400/1132813/ May 23, 30, 2014 14-02317S

SECOND INSERTION

RE-NOTICE OF SALE IN THE CIRCUIT COURT OF THE TWELFTH JUDICIAL CIRCUIT, IN AND FOR SARASOTA COUNTY, FLORIDA

28, PAGE 34, OF THE PUBLIC RECORDS OF SARASOTA COUNTY, FLORIDA

RE-NOTICE OF FORECLOSURE SALE IN THE CIRCUIT COURT OF THE TWELFTH JUDICIAL CIRCUIT, IN AND FOR SARASOTA COUNTY, FLORIDA CIVIL DIVISION... CASE NO.: 2012 CA 006737 NC JPMORGAN CHASE BANK, NATIONAL ASSOCIATION, SUCCESSOR IN INTEREST BY PURCHASE FROM THE FEDERAL DEPOSIT INSURANCE CORPORATION AS RECEIVER OF WASHINGTON MUTUAL BANK F/K/A WASHINGTON MUTUAL BANK, FA Plaintiff, vs. ROY WALTER KELLOGG, IV, et al Defendants.

as set forth in said Lis Pendens, to wit: Lot 5, Block 464 of 8th ADDITION TO PORT CHARLOTTE SUBDIVISION, a Subdivision according to the Plat thereof, as recorded in Plat Book 12, Page 20, of the Public Records of Sarasota County, Florida.

NOTICE OF FORECLOSURE SALE IN THE CIRCUIT COURT IN AND FOR SARASOTA COUNTY, FLORIDA... CASE NO: 2008 CA 006782 SC THE BANK OF NEW YORK AS TRUSTEE FOR THE CERTIFICATEHOLDERS CWALT, INC. ALTERNATIVE LOAN TRUST 2005-1ICB MORTGAGE Plaintiff, vs. CHRISTOPHER MCPHERSON A/K/A CHRISTOPHER I. MCPHERSON; TIANJIAO MCPHERSON A/K/A TIANJIANO MCPHERSON; ANY AND ALL UNKNOWN PARTIES CLAIMING BY, THROUGH, UNDER, AND AGAINST THE HEREIN NAMED INDIVIDUAL DEFENDANT(S) WHO ARE NOT KNOWN TO BE DEAD OR ALIVE, WHETHER SAID UNKNOWN PARTIES MAY CLAIM AN INTEREST AS SPOUSES, HEIRS, DEVISEES, GRANTEES OR OTHER CLAIMANTS; CTM PROPERTIES, LLC AS TRUSTEE UNDER THE TRUST AGREEMENT DATED JANUARY 1, 2006, Defendants.

TO THE PLAT THEREOF RECORDED IN PLAT BOOK 11, PAGE 30, OF THE PUBLIC RECORDS OF SARASOTA COUNTY, FLORIDA

CASE NO. 2007-CA-011949-SC US BANK NATIONAL ASSOCIATION, AS TRUSTEE FOR SG MORTGAGE SECURITIES TRUST 2006-FRE2, ASSET BACKED CERTIFICATES, SERIES 2006-FRE2; Plaintiff, vs. JOHN T. ALLAIRE, ET AL; Defendants NOTICE IS HEREBY GIVEN pursuant to an Order rescheduling foreclosure sale dated MAY 05, 2014 entered in Civil Case No. 2007-CA-011949-SC of the Circuit Court of the TWELFTH Judicial Circuit in and for Sarasota County, Florida, wherein US BANK NATIONAL ASSOCIATION, AS TRUSTEE FOR SG MORTGAGE SECURITIES TRUST 2006-FRE2, ASSET BACKED CERTIFICATES, SERIES 2006-FRE2, Plaintiff and JOHN T. ALLAIRE, ET AL; are defendant(s). The Clerk will sell to the highest and best bidder for cash, AT www.sarasota.realforeclose.com, IN ACCORDANCE WITH CHAPTER 45, FLORIDA STATUTES, AT 9:00 AM, JUNE 12, 2014 the following described property as set forth in said Final Judgment, to-wit:

Property Address: 802 DIANE CR., ENGLEWOOD, FL 34223 ANY PERSON CLAIMING AN INTEREST IN THE SURPLUS FROM THE SALE, IF ANY, OTHER THAN THE PROPERTY OWNER AS OF THE DATE OF THE LIS PENDENS MUST FILE A CLAIM WITHIN 60 DAYS AFTER THE SALE.

Any person claiming an interest in the surplus funds from the sale, if any, other than the property owner as of the date of the lis pendens must file a claim within 60 days after the sale. If you are a person with a disability who needs any accommodation in order to participate in this proceeding, you are entitled, at no cost to you, to the provision of certain assistance. Please contact the Sarasota County Jury Office, P.O. Box 3079, Sarasota, Florida 34230-3079, (941)861-7400, at least seven (7) days before your scheduled court appearance, or immediately upon receiving this notification if the time before the scheduled appearance is less than seven (7) days; if you are hearing or voice impaired, call 711.

Any person claiming an interest in the surplus funds from the sale, if any, other than the property owner as of the date of the lis pendens must file a claim within 60 days after the sale. If you are a person with a disability who needs any accommodation in order to participate in this proceeding, you are entitled, at no cost to you, to the provision of certain assistance. Please contact the Sarasota County Jury Office, P.O. Box 3079, Sarasota, Florida 34230-3079, (941)861-7400, at least seven (7) days before your scheduled court appearance, or immediately upon receiving this notification if the time before the scheduled appearance is less than seven (7) days; if you are hearing or voice impaired, call 711.

NOTICE is hereby given that the Clerk of the Circuit Court of Sarasota County, Florida, will on the 19th day of June 2014, at 9:00 a.m. at www.sarasota.realforeclose.com, offer for sale and sell at public outcry to the highest and best bidder for cash, the following-described property situate in Sarasota County, Florida: LOT 22, BLOCK 171, 2ND ADDITION TO PORT CHARLOTTE SUBDIVISION, ACCORDING

pursuant to the Final Judgment entered in a case pending in said Court, the style of which is indicated above.

LOT 1, OF SPANISH WELLS, A REPLAT OF LOTS 812 AND 813 OF ENGLEWOOD GARDENS, NO. 3 ACCORDING TO THE PLAT THEREOF, AS RECORDED IN PLAT BOOK

If you are a person with a disability who needs any accommodation in order to participate in this proceeding, you are entitled, at no cost to you, to the provision of certain assistance. Please contact the Sarasota County Jury Office, P.O. Box 3079, Sarasota, Florida 34230-3079, (941)861-7400, at least seven (7) days before your scheduled court appearance, or immediately upon receiving this notification if the time before the scheduled appearance is less than seven (7) days; if you are hearing or voice impaired, call 711.

RE-NOTICE IS HEREBY GIVEN pursuant to an Order Granting Plaintiff's Motion to Reschedule Foreclosure Sale filed May 9, 2014 and entered in Case No. 2012 CA 006737 NC of the Circuit Court of the TWELFTH Judicial Circuit in and for SARASOTA COUNTY, Florida, wherein JPMORGAN CHASE BANK, NATIONAL ASSOCIATION, SUCCESSOR IN INTEREST BY PURCHASE FROM THE FEDERAL DEPOSIT INSURANCE CORPORATION AS RECEIVER OF WASHINGTON MUTUAL BANK F/K/A WASHINGTON MUTUAL BANK, FA is Plaintiff, and ROY WALTER KELLOGG, IV, et al are Defendants, the clerk will sell to the highest and best bidder for cash, beginning at 09:00 AM at www.sarasota.realforeclose.com, in accordance with Chapter 45, Florida Statutes, on the 13 day of June, 2014, the following described property

Dated: May 19, 2014 By: /s/ Heather Griffiths Phelan Hallinan, PLC Heather Griffiths, Esq., Florida Bar No. 0091444 Emilio R. Lenzi, Esq., Florida Bar No. 0668273 Phelan Hallinan, PLC Attorneys for Plaintiff 2727 West Cypress Creek Road Ft. Lauderdale, FL 33309 Tel: 954-462-7000 Fax: 954-462-7001 Service by email: FL.Service@PhelanHallinan.com May 23, 30, 2014 14-02302S

NOTICE is hereby given that the Clerk of the Circuit Court of Sarasota County, Florida, will on the 19th day of June 2014, at 9:00 a.m. at www.sarasota.realforeclose.com, offer for sale and sell at public outcry to the highest and best bidder for cash, the following-described property situate in Sarasota County, Florida: LOT 22, BLOCK 171, 2ND ADDITION TO PORT CHARLOTTE SUBDIVISION, ACCORDING

Any person or entity claiming an interest in the surplus, if any, resulting from the foreclosure sale, other than the property owner as of the date of the Lis Pendens, must file a claim on same with the Clerk of Court within 60 days after the foreclosure sale.

If you are a person with a disability who needs any accommodation in order to participate in this proceeding, you are entitled, at no cost to you, to the provision of certain assistance. Please contact the Sarasota County Jury Office, P.O. Box 3079, Sarasota, Florida 34230-3079, (941)861-7400, at least seven (7) days before your scheduled court appearance, or immediately upon receiving this notification if the time before the scheduled appearance is less than seven (7) days; if you are hearing or voice impaired, call 711. DATED this 19th day of May, 2014 John J. Bennett Florida Bar Number: 98257 Brandon R. McDowell, Esquire Florida Bar No: 0072170 BUTLER & HOSCH, P.A. Mailing Address: 3185 South Conway Road, Suite E Orlando, Florida 32812 Telephone: (407) 381-5200 Fax: (407) 381-5577 Attorney for Plaintiff Service of Pleadings Email: FL.Pleadings@butlerandhosch.com B&H # 291768 May 23, 30, 2014 14-02330S

SECOND INSERTION

NOTICE TO CREDITORS
IN THE CIRCUIT COURT FOR
SARASOTA COUNTY, FLORIDA
PROBATE DIVISION
File No. 2014CP001968SC
Division Probate
IN RE: ESTATE OF
JACK JOSEPH PIRILLO
Deceased.

The administration of the estate of Jack Joseph Pirillo, deceased, whose date of death was November 8, 2013, is pending in the Circuit Court for Sarasota County, Florida, Probate Division, the address of which is P.O. Box 48927, Sarasota, Florida 34230. The names and addresses of the personal representatives and the personal representatives' attorney are set forth below.

All creditors of the decedent and other persons having claims or demands against decedent's estate on whom a copy of this notice is required to be served must file their claims with this court WITHIN THE LATER OF 3 MONTHS AFTER THE TIME OF THE FIRST PUBLICATION OF THIS NOTICE OR 30 DAYS AFTER THE DATE OF SERVICE OF A COPY OF THIS NOTICE ON THEM.

All other creditors of the decedent and other persons having claims or demands against decedent's estate must file their claims with this court WITHIN 3 MONTHS AFTER THE DATE OF THE FIRST PUBLICATION OF THIS NOTICE.

ALL CLAIMS NOT FILED WITHIN THE TIME PERIODS SET FORTH IN SECTION 733.702 OF THE FLORIDA PROBATE CODE WILL BE FOREVER BARRED.

NOTWITHSTANDING THE TIME PERIODS SET FORTH ABOVE, ANY CLAIM FILED TWO (2) YEARS OR MORE AFTER THE DECEDENT'S DATE OF DEATH IS BARRED.

The date of first publication of this notice is May 23, 2014.

Personal Representative:

s/ Jacqueline M. Pirillo
Jacqueline M. Pirillo
41 Bergen Drive
Deer Park, New York 11729
s/ Salvatore B. Pirillo
Salvatore B. Pirillo
8 Charter Avenue
Dix Hills, New York 11746

Attorney for Personal Representatives:

s/ Jeffrey M. Backo
Jeffrey M. Backo

Attorney
Florida Bar Number: 0086426
MELLOR & GRISSINGER
13801-D South Tamiami Trail
North Port, FL 34287

Telephone: (941) 426-1193

Fax: (941) 426-5413

E-Mail: jeff@northportlaw.com

Secondary E-Mail:
shelly@northportlaw.com

May 23, 30, 2014 14-02287S

SECOND INSERTION

NOTICE TO CREDITORS
IN THE CIRCUIT COURT FOR
SARASOTA COUNTY, FLORIDA
PROBATE DIVISION
File No. 2014CP001681NC
IN RE: ESTATE OF
WILLIAM G. PFEIL
Deceased.

The administration of the estate of WILLIAM G. PFEIL, deceased, whose date of death was March 27th, 2014, is pending in the Circuit Court for SARASOTA County, Florida, Probate Division, the address of which is P.O. BOX 3079, SARASOTA, FLORIDA 34230. The names and addresses of the personal representative and the personal representative's attorney are set forth below.

All creditors of the decedent and other persons having claims or demands against decedent's estate on whom a copy of this notice is required to be served must file their claims with this court ON OR BEFORE THE LATER OF 3 MONTHS AFTER THE TIME OF THE FIRST PUBLICATION OF THIS NOTICE OR 30 DAYS AFTER THE DATE OF SERVICE OF A COPY OF THIS NOTICE ON THEM.

All other creditors of the decedent and other persons having claims or demands against decedent's estate must file their claims with this court WITHIN 3 MONTHS AFTER THE DATE OF THE FIRST PUBLICATION OF THIS NOTICE.

ALL CLAIMS NOT FILED WITHIN THE TIME PERIODS SET FORTH IN SECTION 733.702 OF THE FLORIDA PROBATE CODE WILL BE FOREVER BARRED.

NOTWITHSTANDING THE TIME PERIODS SET FORTH ABOVE, ANY CLAIM FILED TWO (2) YEARS OR MORE AFTER THE DECEDENT'S DATE OF DEATH IS BARRED.

The date of first publication of this notice is May 23, 2014.

Personal Representative:

KAREN FINER
35 BOCKET STREET
PEARL RIVER, NEW YORK 10965
SANDY ALAN LEVITT, P.A.
Attorneys for Personal Representative
2201 RINGLING BOULEVARD
SUITE 203

SARASOTA, FL 34237

Florida Bar No. 0282529

May 23, 30, 2014 14-02310S

SECOND INSERTION

NOTICE TO CREDITORS
IN THE CIRCUIT COURT FOR
SARASOTA COUNTY, FLORIDA
PROBATE DIVISION
File: 2014-CP-001538-CP
Division Probate
IN RE: ESTATE OF
GEORGE F. HUYER
Deceased.

The administration of the estate of George F. Huyer, deceased, whose date of death was June 16, 2013, is pending in the Circuit Court for Sarasota County, Florida, Probate Division, the address of which is PO Box 3079, Sarasota, Florida 34230. The names and addresses of the personal representative and the personal representative's attorney are set forth below.

All creditors of the decedent and other persons having claims or demands against decedent's estate on whom a copy of this notice is required to be served must file their claims with this court WITHIN THE LATER OF 3 MONTHS AFTER THE TIME OF THE FIRST PUBLICATION OF THIS NOTICE OR 30 DAYS AFTER THE DATE OF SERVICE OF A COPY OF THIS NOTICE ON THEM.

All other creditors of the decedent and other persons having claims or demands against decedent's estate must file their claims with this court WITHIN 3 MONTHS AFTER THE DATE OF THE FIRST PUBLICATION OF THIS NOTICE.

ALL CLAIMS NOT FILED WITHIN THE TIME PERIODS SET FORTH IN SECTION 733.702 OF THE FLORIDA PROBATE CODE WILL BE FOREVER BARRED.

NOTWITHSTANDING THE TIME PERIODS SET FORTH ABOVE, ANY CLAIM FILED TWO (2) YEARS OR MORE AFTER THE DECEDENT'S DATE OF DEATH IS BARRED.

The date of first publication of this notice is May 23, 2014.

Personal Representative:

Father Michael Cronogue
Society of Saint Edmond
270 Winooski Park
Colchester, Vermont 05439

Attorney for Personal Representative:

Charles Diez, Jr.

Florida Bar Number: 019646

Diez & Floyd, P.A.

737 South Indiana Avenue

Suite A

Englewood, FL 34223

Telephone: (941) 474-5506

Fax: (941) 474-5507

E-Mail: diezandfloyd@aol.com

Secondary: diezandfloyd@

diezandfloydpa.comcastbiz.net

May 23, 30, 2014 14-02308S

SECOND INSERTION

NOTICE TO CREDITORS
IN THE CIRCUIT COURT FOR
SARASOTA COUNTY, FLORIDA
PROBATE DIVISION
File No. 2014 CP 001935
IN RE: ESTATE OF
BERNICE L. CHILDS
Deceased.

The administration of the estate of Bernice L. Childs, deceased, whose date of death was April 12th, 2014, is pending in the Circuit Court for Sarasota County, Florida, Probate Division, the address of which is P.O. Box 3079 Sarasota, Florida 34236. The names and addresses of the personal representative and the personal representative's attorney are set forth below.

All creditors of the decedent and other persons having claims or demands against decedent's estate on whom a copy of this notice is required to be served must file their claims with this court ON OR BEFORE THE LATER OF 3 MONTHS AFTER THE TIME OF THE FIRST PUBLICATION OF THIS NOTICE OR 30 DAYS AFTER THE DATE OF SERVICE OF A COPY OF THIS NOTICE ON THEM.

All other creditors of the decedent and other persons having claims or demands against decedent's estate must file their claims with this court WITHIN 3 MONTHS AFTER THE DATE OF THE FIRST PUBLICATION OF THIS NOTICE.

ALL CLAIMS NOT FILED WITHIN THE TIME PERIODS SET FORTH IN SECTION 733.702 OF THE FLORIDA PROBATE CODE WILL BE FOREVER BARRED.

NOTWITHSTANDING THE TIME PERIODS SET FORTH ABOVE, ANY CLAIM FILED TWO (2) YEARS OR MORE AFTER THE DECEDENT'S DATE OF DEATH IS BARRED.

The date of first publication of this notice is May 23rd, 2014.

Personal Representative:

Margaret A. Vodnansky
490 N.W. Spring Hollow Blvd.
Lake City, Florida 32055

SHUMAKER, LOOP &

KENDRICK, LLP

Attorneys for Personal Representative

P. O. BOX 49948

SARASOTA, FL 34230

Florida Bar No. 0089559

By: Benjamin R. Hanan, Esquire

May 23, 30, 2014 14-02312S

SECOND INSERTION

NOTICE TO CREDITORS
IN THE CIRCUIT COURT FOR
SARASOTA COUNTY, FLORIDA
PROBATE DIVISION
File No. 2014 CP 001432 SC
IN RE: ESTATE OF
AHMED JAMSHIDI
Deceased.

The ancillary administration of the estate of Ahmed Jamshidi, deceased, whose date of death was December 1, 2013 is pending in the Circuit Court for Sarasota County, Florida, Probate Division, the address of which is P.O. Box 3079, Sarasota, Florida, 34230. The names and addresses of the ancillary personal representative and the ancillary personal representative's attorney are set forth below.

All creditors of the decedent and other persons having claims or demands against decedent's estate on whom a copy of this notice is required to be served must file their claims with this court WITHIN THE LATER OF 3 MONTHS AFTER THE TIME OF THE FIRST PUBLICATION OF THIS NOTICE OR 30 DAYS AFTER THE DATE OF SERVICE OF A COPY OF THIS NOTICE ON THEM.

All other creditors of the decedent and other persons having claims or demands against decedent's estate must file their claims with this court WITHIN 3 MONTHS AFTER THE DATE OF THE FIRST PUBLICATION OF THIS NOTICE.

ALL CLAIMS NOT FILED WITHIN THE TIME PERIODS SET FORTH IN SECTION 733.702 OF THE FLORIDA PROBATE CODE WILL BE FOREVER BARRED.

NOTWITHSTANDING THE TIME PERIODS SET FORTH ABOVE, ANY CLAIM FILED TWO (2) YEARS OR MORE AFTER THE DECEDENT'S DATE OF DEATH IS BARRED.

The date of first publication of this notice is May 23, 2014.

Ancillary Personal Representative:

Faezeh Phillips Jamshidi
51 Strawberry Lane
Shelton, CT 06484

Attorney for Ancillary Personal

Representative:

Andrew J. Britton, Esq.

Florida Bar Number: 213500

401 Johnson Lane, Suite 102

Venice, FL 34285

Telephone: (941) 408-8008

Fax: (941) 408-0722

E-Mail: brittonlaw@gmail.com

Secondary E-Mail: FOR SERVICE OF

DOCUMENTS

e-service@andrewbrittonlaw.com

May 23, 30, 2014 14-02320S

SECOND INSERTION

NOTICE TO CREDITORS
IN THE CIRCUIT COURT FOR
SARASOTA COUNTY, FLORIDA
PROBATE DIVISION
File No. 2014CP1302
Division Probate
IN RE: ESTATE OF
STEPHEN J. KERLEY, JR.
Deceased.

The administration of the estate of STEPHEN J. KERLEY, JR., deceased, whose date of death was March 16, 2014, is pending in the Circuit Court for Sarasota County, Florida, Probate Division, the address of which is 2000 Main Street, Sarasota, Florida 34237. The names and addresses of the personal representative and the personal representative's attorney are set forth below.

All creditors of the decedent and other persons having claims or demands against decedent's estate on whom a copy of this notice is required to be served must file their claims with this court ON OR BEFORE THE LATER OF 3 MONTHS AFTER THE TIME OF THE FIRST PUBLICATION OF THIS NOTICE OR 30 DAYS AFTER THE DATE OF SERVICE OF A COPY OF THIS NOTICE ON THEM.

All other creditors of the decedent and other persons having claims or demands against decedent's estate must file their claims with this court WITHIN 3 MONTHS AFTER THE DATE OF THE FIRST PUBLICATION OF THIS NOTICE.

ALL CLAIMS NOT FILED WITHIN THE TIME PERIODS SET FORTH IN SECTION 733.702 OF THE FLORIDA PROBATE CODE WILL BE FOREVER BARRED.

NOTWITHSTANDING THE TIME PERIODS SET FORTH ABOVE, ANY CLAIM FILED TWO (2) YEARS OR MORE AFTER THE DECEDENT'S DATE OF DEATH IS BARRED.

The date of first publication of this notice is May 23, 2014.

Personal Representative:

STEPHANIE TIMMONS
23 Breezy Knoll Lane
Lake St. Louis, MO 63367

Attorney for Personal Representative:

Melissa R. Casanueva

FL Bar No. 0105788

6148 State Road 70 East

Bradenton, Florida 34203

Telephone: (941) 756-6600

Email: Melissa@gerlinglawgroup.com

May 23, 30, 2014 14-02309S

SECOND INSERTION

NOTICE TO CREDITORS
IN THE CIRCUIT COURT FOR
SARASOTA COUNTY, FLORIDA
PROBATE DIVISION
File No. 2014CP001766NC
IN RE: ESTATE OF
DEBORAH WATTERSON
SCHROCK, A/K/A DEBORAH H.
SCHROCK
Deceased.

The administration of the estate of DEBORAH WATTERSON SCHROCK A/K/A DEBORAH H. SCHROCK, deceased, whose date of death was February 18, 2014, is pending in the Circuit Court for Sarasota County, Florida, Probate Division, the address of which is P.O. Box 3079, Sarasota, FL 34230. The names and addresses of the personal representative and the personal representative's attorney are set forth below.

All creditors of the decedent and other persons having claims or demands against decedent's estate on whom a copy of this notice is required to be served must file their claims with this court ON OR BEFORE THE LATER OF THREE (3) MONTHS AFTER THE TIME OF THE FIRST PUBLICATION OF THIS NOTICE OR THIRTY (30) DAYS AFTER THE DATE OF SERVICE OF A COPY OF THIS NOTICE ON THEM.

All other creditors of the decedent and other persons having claims or demands against decedent's estate must file their claims with this court WITHIN THREE (3) MONTHS AFTER THE DATE OF THE FIRST PUBLICATION OF THIS NOTICE.

ALL CLAIMS NOT FILED WITHIN THE TIME PERIODS SET FORTH IN SECTION 733.702 OF THE FLORIDA PROBATE CODE WILL BE FOREVER BARRED.

NOTWITHSTANDING THE TIME PERIODS SET FORTH ABOVE, ANY CLAIM FILED TWO (2) YEARS OR MORE AFTER THE DECEDENT'S DATE OF DEATH IS BARRED.

The date of first publication of this notice is: May 23, 2014.

Personal Representative:

Kurtis L. Watterson
10 Schapansky Road
Cochranville, PA 19330

Attorney for Personal Representative:

Richard D. Saba, Esq.

Richard D. Saba, P.A.

Florida Bar No. 175810

2033 Main Street, Suite 303

Sarasota, FL 34237

rsaba@rsabalaw.com

Ph: (941) 952-0990

May 23, 30, 2014 14-02311S

SECOND INSERTION

NOTICE TO CREDITORS
IN THE CIRCUIT COURT FOR
SARASOTA COUNTY, FLORIDA
PROBATE DIVISION
File No. 2013CP004750NC
IN RE: ESTATE OF
REGINA SIENIAWSKI
Deceased.

The administration of the estate of Regina Sieniawski, deceased, whose date of death was September 25, 2013, is pending in the Circuit Court for Sarasota County, Florida, Probate Division, the address of which is 2000 Main Street, Sarasota, Florida 34237. The names and addresses of the personal representative and the personal representative's attorney are set forth below.

All creditors of the decedent and other persons having claims or demands against decedent's estate on whom a copy of this notice is required to be served must file their claims with this court WITHIN THE LATER OF 3 MONTHS AFTER THE TIME OF THE FIRST PUBLICATION OF THIS NOTICE OR 30 DAYS AFTER THE DATE OF SERVICE OF A COPY OF THIS NOTICE ON THEM.

All other creditors of the decedent and other persons having claims or demands against decedent's estate must file their claims with this court WITHIN 3 MONTHS AFTER THE DATE OF THE FIRST PUBLICATION OF THIS NOTICE.

ALL CLAIMS NOT FILED WITHIN THE TIME PERIODS SET FORTH IN SECTION 733.702 OF THE FLORIDA PROBATE CODE WILL BE FOREVER BARRED.

NOTWITHSTANDING THE TIME PERIODS SET FORTH ABOVE, ANY CLAIM FILED TWO (2) YEARS OR MORE AFTER THE DECEDENT'S DATE OF DEATH IS BARRED.

The date of first publication of this notice is May 23, 2014.

Personal Representative:

Krzysztof Owczarek
1364 Piedmont Road
Venice, FL 34293-5361

Attorney for Personal Representative:

Lauren M. Przybyla, Esquire

Florida Bar No.: 89573

PRZYBYLA LAW, P.A.

6605 Superior Avenue

Sarasota, FL 34231

Phone: (941) 448-3077

Facsimile: (941) 893-3355

e-mail: lauren@laurenplaw.com

May 23, 30, 2014 14-02288S

SECOND INSERTION

NOTICE TO CREDITORS
IN THE CIRCUIT COURT FOR
SARASOTA COUNTY, FLORIDA
PROBATE DIVISION
File No. 2014 CP 1300
IN RE: ESTATE OF
HENRY HERMAN HODGSON
Deceased.

The administration of the estate of HENRY HERMAN HODGSON, deceased, whose date of death was March 11, 2014; File Number 2014 CP 1300, is pending in the Circuit Court for Sarasota County, Florida, Probate Division, the address of which is 2000 Main St., Sarasota, FL 34236. The names and addresses of the personal representative and the personal representative's attorney are set forth below.

All creditors of the decedent and other persons having claims or demands against decedent's estate, on whom a copy of this notice is required to be served must file their claims with this court ON OR BEFORE THE LATER OF 3 MONTHS AFTER THE TIME OF THE FIRST PUBLICATION OF THIS NOTICE OR 30 DAYS AFTER THE DATE OF SERVICE OF A COPY OF THIS NOTICE ON THEM.

All other creditors of the decedent and other persons having claims or demands against decedent's estate must file their claims with this court WITHIN 3 MONTHS AFTER THE DATE OF THE FIRST PUBLICATION OF THIS NOTICE.

ALL CLAIMS NOT FILED WITHIN THE TIME PERIODS SET FORTH IN SECTION 733.702 OF THE FLORIDA PROBATE CODE WILL BE FOREVER BARRED.

NOTWITHSTANDING THE TIME PERIOD SET FORTH ABOVE, ANY CLAIM FILED TWO (2) YEARS OR MORE AFTER THE DECEDENT'S DATE OF DEATH IS BARRED.

The date of first publication of this notice is: May 23, 2014.

ELISSA WYATT HODGSON

Personal Representative
1358 Landings Blvd
Sarasota, FL 34236

John J. Waskom

Attorney for Personal Representative

Email: jwaskom@icardmerrill.com

Secondary Email:

swade@icardmerrill.com

Florida Bar No. 0962181

ICARD, MERRILL, CULLIS, TIMM,

FUREN & GINSBURG, P.A.

2033 Main St., Ste. 500

Sarasota, FL 34237

Telephone: 941-366-8100

941-366-5263

May 23, 30, 2014 14-02265S

SECOND INSERTION

NOTICE TO CREDITORS
IN THE CIRCUIT COURT FOR
SARASOTA COUNTY, FLORIDA
PROBATE DIVISION
File No. 2014 CP 1358 NC
IN RE: ESTATE OF
BARBARA SARKIN
Deceased.

The administration of the estate of BARBARA SARKIN, deceased, whose date of death was December 23, 2013, is pending in the Circuit Court for Sarasota County, Florida, Probate Division, the address of which is 2000 Main Street, Sarasota, Florida 34237. The names and addresses of the personal representative and the personal representative's attorney are set forth below.

All creditors of the decedent and other persons having claims or demands against decedent's estate on whom a copy of this notice is required to be served must file their claims with this court WITHIN THE LATER OF 3 MONTHS AFTER THE TIME OF THE FIRST PUBLICATION OF THIS NOTICE OR 30 DAYS AFTER THE DATE OF SERVICE OF A COPY OF THIS NOTICE ON THEM.

All other creditors of the decedent and other persons having claims or demands against decedent's estate must file their claims with this court WITHIN 3 MONTHS AFTER THE DATE OF THE FIRST PUBLICATION OF THIS NOTICE.

ALL CLAIMS NOT FILED WITHIN THE TIME PERIODS SET FORTH IN SECTION 733.702 OF THE FLORIDA PROBATE CODE WILL BE FOREVER BARRED.

NOTWITHSTANDING THE TIME PERIODS SET FORTH ABOVE, ANY CLAIM FILED TWO (2) YEARS OR MORE AFTER THE DECEDENT'S DATE OF DEATH IS BARRED.

The date of first publication of this notice is May 23, 2014.

Personal Representative:

KARMY PERETZ
2523 Riverbluff Parkway
Sarasota, Florida 34231

Attorney for Personal Representative:

WILLIAM H. BEHRENFELD

SECOND INSERTION

NOTICE TO CREDITORS
IN THE CIRCUIT COURT
FOR SARASOTA COUNTY,
FLORIDA
PROBATE DIVISION
File No. 2014 CP 002001 NC
IN RE: ESTATE OF
PAULINE M. SIVERTSEN
Deceased.

The administration of the estate of PAULINE M. SIVERTSEN, deceased, whose date of death was April 22, 2014; is pending in the Circuit Court for Sarasota County, Florida, Probate Division; File Number 2014 CP 1187 NC; the address of which is P.O. Box 48927, Sarasota, FL 34230. The name and address of the personal representative and the personal representative's attorney are set forth below.

All creditors of the decedent and other persons, who have claims or demands against decedent's estate, including unmatured, contingent or unliquidated claims, and who have been served a copy of this notice, must file their claims with this court WITHIN THE LATER OF THREE (3) MONTHS AFTER THE DATE OF THE FIRST PUBLICATION OF THIS NOTICE OR THIRTY (30) DAYS AFTER THE DATE OF SERVICE OF A COPY OF THIS NOTICE ON THEM.

All other creditors of the decedent and other persons having claims or demands against decedent's estate, including unmatured, contingent or unliquidated claims, must file their claims with this court WITHIN THREE (3) MONTHS AFTER THE DATE OF THE FIRST PUBLICATION OF THIS NOTICE.

ALL CLAIMS NOT SO FILED WILL BE FOREVER BARRED.

NOTWITHSTANDING THE TIME PERIODS SET FORTH ABOVE, ANY CLAIM FILED TWO (2) YEARS OR MORE AFTER THE DECEDENT'S DATE OF DEATH IS BARRED.

THE DATE OF FIRST PUBLICATION OF THIS NOTICE IS: May 23, 2014.

Personal Representative:

KAREN SELLERS
4084 47TH St.
Sarasota, FL 34235
Attorney for Personal Representative:
George Browning III, PA
Attorney
Florida Bar No. 125555
46 N. Washington Blvd.
No. 27
Sarasota, FL 34236
941 366 2782
May 23, 30, 2014 14-02326S

SECOND INSERTION

NOTICE TO CREDITORS
IN THE CIRCUIT COURT FOR
SARASOTA COUNTY, FLORIDA
File No. 2014-CP-001951 NC
Probate Division
IN RE: ESTATE OF
MARY ANNE KADY,
Deceased.

The administration of the estate of MARY ANNE KADY, deceased, whose date of death was January 29, 2014, is pending in the Circuit Court for Sarasota County, Florida, Probate Division, the address of which is P. O. Box 3079, Sarasota, FL 34230. The names and addresses of the personal representative and the personal representative's attorney are set forth below.

All creditors of the decedent and other persons having claims or demands against decedent's estate, on whom a copy of this notice is required to be served, must file their claims with this court ON OR BEFORE THE LATER OF 3 MONTHS AFTER THE TIME OF THE FIRST PUBLICATION OF THIS NOTICE OR 30 DAYS AFTER THE DATE OF SERVICE OF A COPY OF THIS NOTICE ON THEM.

All other creditors of the decedent and other persons having claims or demands against decedent's estate must file their claims with this court WITHIN 3 MONTHS AFTER THE DATE OF THE FIRST PUBLICATION OF THIS NOTICE.

ALL CLAIMS NOT FILED WITHIN THE TIME PERIODS SET FORTH IN SECTION 733.702 OF THE FLORIDA PROBATE CODE WILL BE FOREVER BARRED.

NOTWITHSTANDING THE TIME PERIOD SET FORTH ABOVE, ANY CLAIM FILED TWO (2) YEARS OR MORE AFTER THE DECEDENT'S DATE OF DEATH IS BARRED.

The date of first publication of this notice is: May 23, 2014.

Signed on May 20, 2014.

LISA KADY HOFFMAN

Personal Representative
2732 Hatton Street
Sarasota, FL 34237
Charla M. Burchett, Esquire
Attorney for Personal Representative
Florida Bar No. 0813230
Charla M. Burchett, PLC
766 Hudson Avenue,
Ste. C
Sarasota, FL 34236-7739
Telephone: (941)-951-1866
Email: cmb@burchettlaw.com
Secondary E-mail:
court@burchettlaw.com
May 23, 30, 2014 14-02325S

SECOND INSERTION

NOTICE TO CREDITORS
IN THE CIRCUIT COURT FOR
SARASOTA COUNTY, FLORIDA
PROBATE DIVISION
File No. 2014-CP-001718-NC
IN RE: ESTATE OF
STEVEN E. FISHER
Deceased.

The administration of the estate of STEVEN E. FISHER, deceased, whose date of death was March 18, 2014; File Number 2014-CP-001718-NC, is pending in the Circuit Court for Sarasota County, Florida, Probate Division, the address of which is 2000 Main Street, Sarasota, Florida 34237. The names and addresses of the personal representative and the personal representative's attorney are set forth below.

All creditors of the decedent and other persons having claims or demands against decedent's estate, on whom a copy of this notice is required to be served must file their claims with this court ON OR BEFORE THE LATER OF 3 MONTHS AFTER THE TIME OF THE FIRST PUBLICATION OF THIS NOTICE OR 30 DAYS AFTER THE DATE OF SERVICE OF A COPY OF THIS NOTICE ON THEM.

All other creditors of the decedent and other persons having claims or demands against decedent's estate must file their claims with this court WITHIN 3 MONTHS AFTER THE DATE OF THE FIRST PUBLICATION OF THIS NOTICE.

ALL CLAIMS NOT FILED WITHIN THE TIME PERIODS SET FORTH IN SECTION 733.702 OF THE FLORIDA PROBATE CODE WILL BE FOREVER BARRED.

NOTWITHSTANDING THE TIME PERIOD SET FORTH ABOVE, ANY CLAIM FILED TWO (2) YEARS OR MORE AFTER THE DECEDENT'S DATE OF DEATH IS BARRED.

The date of first publication of this notice is: May 23, 2014.

KRISTEN IRENE FISHER f/k/a

KRISTEN FISHER-JARVIS
Personal Representative
2503 East Central Boulevard, Unit 15
Orlando, Florida 32803
Mary Lynn Desjarlais
Attorney for Personal Representative
Email:
mldesjarlais@attorneydesjarlais.com
Secondary Email: none
Florida Bar No. 0347469
Mary Lynn Desjarlais, P.A.
2750 Stickney Point Road,
Suite 201
Sarasota, FL 34231
Telephone: 941-923-3388
May 23, 30, 2014 14-02333S

SECOND INSERTION

NOTICE TO CREDITORS
IN THE CIRCUIT COURT FOR
SARASOTA COUNTY, FLORIDA
PROBATE DIVISION
File No. 2014 CP 1917 NC
IN RE: ESTATE OF
SAM P. DAVIS JR.,
Deceased.

The administration of the estate of SAM P. DAVIS JR., deceased, whose date of death was April 21, 2014, is pending in the Circuit Court for Sarasota County, Florida, Probate Division, the address of which is P.O. Box 3079, Sarasota, FL 34230. The names and addresses of the personal representative and the personal representative's attorney are set forth below.

All creditors of the decedent and other persons having claims or demands against decedent's estate on whom a copy of this notice is required to be served must file their claims with this court ON OR BEFORE THE LATER OF 3 MONTHS AFTER THE TIME OF THE FIRST PUBLICATION OF THIS NOTICE OR 30 DAYS AFTER THE DATE OF SERVICE OF A COPY OF THIS NOTICE ON THEM.

All other creditors of the decedent and other persons having claims or demands against decedent's estate must file their claims with this court WITHIN 3 MONTHS AFTER THE DATE OF THE FIRST PUBLICATION OF THIS NOTICE.

ALL CLAIMS NOT FILED WITHIN THE TIME PERIODS SET FORTH IN SECTION 733.702 OF THE FLORIDA PROBATE CODE WILL BE FOREVER BARRED.

NOTWITHSTANDING THE TIME PERIOD SET FORTH ABOVE, ANY CLAIM FILED TWO (2) YEARS OR MORE AFTER THE DECEDENT'S DATE OF DEATH IS BARRED.

The date of first publication of this notice is May 23, 2014.

Personal Representative:

THE NORTHERN TRUST COMPANY
1515 Ringling Boulevard
Sarasota, FL 34236
Attorney for Personal Representative:
WILLIAM T. HARRISON
Florida Bar No. 0034232
Williams Parker Harrison Dietz & Getzen
200 S. Orange Ave.
Sarasota, FL 34236
Telephone: 941-366-4800
Designation of Email Addresses for service:
Primary:
wharrison@williamsparker.com
Secondary:
ltraver@williamsparker.com
May 23, 30, 2014 14-02327S

SECOND INSERTION

NOTICE TO CREDITORS
IN THE CIRCUIT COURT FOR
SARASOTA COUNTY, FLORIDA
PROBATE DIVISION
File No. 2014 CP 1984 PR
IN RE: ESTATE OF
MILDRED T. BAKER
a.k.a MILDRED BAKER
Deceased.

The administration of the estate of MILDRED T. BAKER a.k.a. MILDRED BAKER, deceased, whose date of death was May 6, 2014, is pending in the Circuit Court for SARASOTA County, Florida, Probate Division, the post office address of which is P.O. Box 3079, Sarasota, Florida 34230-3079. The names and addresses of the personal representative and the personal representative's attorney are set forth below.

All creditors of the decedent and other persons having claims or demands against decedent's estate on whom a copy of this notice is required to be served must file their claims with this court WITHIN THE LATER OF 3 MONTHS AFTER THE TIME OF THE FIRST PUBLICATION OF THIS NOTICE OR 30 DAYS AFTER THE DATE OF SERVICE OF A COPY OF THIS NOTICE ON THEM.

All other creditors of the decedent and other persons having claims or demands against decedent's estate must file their claims with this court WITHIN 3 MONTHS AFTER THE DATE OF THE FIRST PUBLICATION OF THIS NOTICE.

ALL CLAIMS NOT FILED WITHIN THE TIME PERIODS SET FORTH IN SECTION 733.702 OF THE FLORIDA PROBATE CODE WILL BE FOREVER BARRED.

NOTWITHSTANDING THE TIME PERIOD SET FORTH ABOVE, ANY CLAIM FILED TWO (2) YEARS OR MORE AFTER THE DECEDENT'S DATE OF DEATH IS BARRED.

The date of first publication of this notice is May 23, 2014.

Personal Representative:

ROBERT P. SCHEB
2750 Ringling Blvd., Suite 3
Sarasota, Florida 34237
Attorney for Personal Representative:
ROBERT P. SCHEB
E-Mail Address:
rscheb@bowmangeorge.com
Florida Bar No. 398519
BOWMAN, GEORGE, SCHEB, KIMBROUGH & KOACH, P.A.
2750 Ringling Boulevard, Suite 3
Sarasota, Florida 34237
Telephone (941) 366-5510
May 23, 30, 2014 14-02334S

SECOND INSERTION

NOTICE TO CREDITORS
IN THE CIRCUIT COURT FOR
SARASOTA COUNTY, FLORIDA
PROBATE DIVISION
File No. 2014 CP 1983 PR
IN RE: ESTATE OF
ROLAND R. BRASSARD
Deceased.

The administration of the ROLAND R. BRASSARD, deceased, whose date of death was April 27, 2014, is pending in the Circuit Court for SARASOTA County, Florida, Probate Division, the post office address of which is P.O. Box 3079, Sarasota, Florida 34230-3079. The names and addresses of the personal representative and the personal representative's attorney are set forth below.

All creditors of the decedent and other persons having claims or demands against decedent's estate on whom a copy of this notice is required to be served must file their claims with this court WITHIN THE LATER OF 3 MONTHS AFTER THE TIME OF THE FIRST PUBLICATION OF THIS NOTICE OR 30 DAYS AFTER THE DATE OF SERVICE OF A COPY OF THIS NOTICE ON THEM.

All other creditors of the decedent and other persons having claims or demands against decedent's estate must file their claims with this court WITHIN 3 MONTHS AFTER THE DATE OF THE FIRST PUBLICATION OF THIS NOTICE.

ALL CLAIMS NOT FILED WITHIN THE TIME PERIODS SET FORTH IN SECTION 733.702 OF THE FLORIDA PROBATE CODE WILL BE FOREVER BARRED.

NOTWITHSTANDING THE TIME PERIOD SET FORTH ABOVE, ANY CLAIM FILED TWO (2) YEARS OR MORE AFTER THE DECEDENT'S DATE OF DEATH IS BARRED.

The date of first publication of this notice is May 23, 2014.

Personal Representative:

Patricia B. Small
18 Dalton Parkway
Salem, Massachusetts 01970-3110
Attorney for Personal Representative:
ROBERT P. SCHEB
E-Mail Address:
rscheb@bowmangeorge.com
Florida Bar No. 398519
BOWMAN, GEORGE, SCHEB, KIMBROUGH & KOACH, P.A.
2750 Ringling Boulevard, Suite 3
Sarasota, Florida 34237
Telephone (941) 366-5510
May 23, 30, 2014 14-02335S

SECOND INSERTION

NOTICE TO CREDITORS
IN THE CIRCUIT COURT FOR
SARASOTA COUNTY, FLORIDA
PROBATE DIVISION
File No. 2014 CP 001940 NC
IN RE: ESTATE OF
MARY ELIZABETH BLOECHL
a.k.a ELIZABETH A. BLOECHL
a.k.a MARY ELIZABETH ARNALL
BLOECHL
a.k.a MARY A. BLOECHL
a.k.a MARY B. BLOECHL
a.k.a BETH A. BLOECHL
Deceased.

The administration of the estate of MARY ELIZABETH BLOECHL, a.k.a ELIZABETH A. BLOECHL, a.k.a MARY ELIZABETH ARNALL BLOECHL, a.k.a MARY A. BLOECHL, a.k.a MARY B. BLOECHL, a.k.a BETH A. BLOECHL, deceased, whose date of death was April 28, 2014, and whose social security number are xxx-xx-0684, is pending in the Circuit Court for Sarasota County, Florida, Probate Division, the address of which

is P. O. Box 3079, Sarasota, Florida 34230. The names and addresses of the personal representatives and the personal representatives' attorney are set forth below.

All creditors of the decedent and other persons having claims or demands against decedent's estate on whom a copy of this notice is required to be served must file their claims with this court WITHIN THE LATER OF 3 MONTHS AFTER THE TIME OF THE FIRST PUBLICATION OF THIS NOTICE OR 30 DAYS AFTER THE DATE OF SERVICE OF A COPY OF THIS NOTICE ON THEM.

All other creditors of the decedent and other persons having claims or demands against decedent's estate must file their claims with this court WITHIN 3 MONTHS AFTER THE DATE OF THE FIRST PUBLICATION OF THIS NOTICE.

ALL CLAIMS NOT FILED WITHIN THE TIME PERIODS SET FORTH IN SECTION 733.702 OF THE FLORIDA PROBATE CODE

WILL BE FOREVER BARRED.

NOTWITHSTANDING THE TIME PERIOD SET FORTH ABOVE, ANY CLAIM FILED TWO (2) YEARS OR MORE AFTER THE DECEDENT'S DATE OF DEATH IS BARRED.

The date of first publication of this notice is May 23, 2014.

Personal Representatives:

MARK W. BLOECHL
11914 Shadow Run Boulevard
Riverview, Florida 33569-6316
SUSAN B. GAILLARD
2471 Arlington Street
Sarasota, Florida 34239
Attorney for Personal Representative:
JOHN J. LYONS, Esq.
E-Mail Address:
john@lyonsbeaudryharrison.com
E-Mail Address:
ann@lyonsbeaudryharrison.com
Florida Bar No. 049193
LYONS, BEAUDRY & HARRISON, P.A.
1605 Main Street, Suite. 1111
Sarasota, Florida 34236-5809
Telephone: (941) 366-3282
May 23, 30, 2014 14-02337S

SECOND INSERTION

NOTICE TO CREDITORS
IN THE CIRCUIT COURT FOR
SARASOTA COUNTY, FLORIDA
PROBATE DIVISION
File No. 2014-CP-1977 NC
IN RE: ESTATE OF
DONALD W. DITZ
Deceased.

The administration of the DONALD W. DITZ, deceased, whose date of death was May 7, 2014, is pending in the Circuit Court for SARASOTA County, Florida, Probate Division, the post office address of which is P.O. Box 3079, Sarasota, Florida 34230-3079. The names and addresses of the personal representative and the personal representative's attorney are set forth below.

All creditors of the decedent and other persons having claims or demands against decedent's estate on whom a copy of this notice is required to be served must file their claims with this court WITHIN THE LATER OF 3 MONTHS AFTER THE TIME OF THE FIRST PUBLICATION OF THIS NOTICE OR 30 DAYS AFTER THE DATE OF SERVICE OF A COPY OF THIS NOTICE ON THEM.

All other creditors of the decedent and other persons having claims or demands against

decedent's estate must file their claims with this court WITHIN 3 MONTHS AFTER THE DATE OF THE FIRST PUBLICATION OF THIS NOTICE.

ALL CLAIMS NOT FILED WITHIN THE TIME PERIODS SET FORTH IN SECTION 733.702 OF THE FLORIDA PROBATE CODE WILL BE FOREVER BARRED.

NOTWITHSTANDING THE TIME PERIOD SET FORTH ABOVE, ANY CLAIM FILED TWO (2) YEARS OR MORE AFTER THE DECEDENT'S DATE OF DEATH IS BARRED.

The date of first publication of this notice is May 23, 2014.

Personal Representative:

MICHAEL W. DITZ
P.O. Box 7311
Santa Monica, California 90406
Attorney for Personal Representative:
ROBERT P. SCHEB
E-Mail Address:
rscheb@bowmangeorge.com
Florida Bar No. 398519
BOWMAN, GEORGE, SCHEB, KIMBROUGH & KOACH, P.A.
2750 Ringling Boulevard,
Suite 3
Sarasota, Florida 34237
Telephone (941) 366-5510
May 23, 30, 2014 14-02336S

SECOND INSERTION

NOTICE OF RESCHEDULED SALE
IN THE CIRCUIT COURT OF THE
TWELFTH JUDICIAL CIRCUIT
IN AND FOR SARASOTA COUNTY,
FLORIDA
CIVIL ACTION
CASE NO.: 2011 CA 000312 NC
DIVISION: A
WELLS FARGO BANK, N.A.,
Plaintiff, vs.
LUBOV MELNICHENKO, et al,
Defendant(s).

NOTICE IS HEREBY GIVEN Pursuant to an Order Rescheduling Foreclosure Sale dated on or about April 11, 2014, and entered in Case No. 2011 CA 000312 NC of the Circuit Court of the Twelfth Judicial Circuit in and for Sarasota County, Florida in which Wells Fargo Bank, N.A., is the Plaintiff and Lubov Melnichenko, Pavel Melnichenko, are defendants, the Sarasota County Clerk of the Circuit Court will sell to the highest and best bidder for cash in/on the Internet: www.sarasota.realforeclose.com, Sarasota County, Florida at 9:00am on the 10th day of June, 2014, the following described property as set forth in said Final Judgment of Foreclosure:

LOT 1, BLOCK 558, OF EIGHTEENTH ADDITION TO PORT CHARLOTTE SUBDIVISION, ACCORDING TO THE PLAT THEREOF, AS RECORDED IN PLAT BOOK 14, PAGES 6, 6A THROUGH 6V, OF THE PUBLIC RECORDS OF SARASOTA COUNTY, FLORIDA.

A/K/A 2652 PEAKE STREET, NORTH PORT, FL 34286
Any person claiming an interest in the surplus from the sale, if any, other than the property owner as of the date of the Lis Pendens must file a claim within 60 days after the sale.

If you are a person with a disability who needs any accommodation in order to participate in this proceeding, you are entitled, at no cost to you, to the provision of certain assistance. Please contact the Sarasota County Jury Office, P.O. Box 3079, Sarasota, Florida 34230-3079, (941)861-7400, at least seven (7) days before your scheduled court appearance, or immediately upon receiving this notification if the time before the scheduled appearance is less than seven (7) days; if you are hearing or voice impaired, call 711.

/s/ Douglas Gerber
August J. Stanton, III
Florida Bar No. 0976113
Douglas Gerber
Florida Bar No. 15269
STANTON & GASKICK, P.A.
390 N. Orange Avenue,
Suite 260
Orlando, Florida 32801
Ph. (407) 423-5203; Fax 425-4105
E-mail:
pleadings@sg-law.us/rmf@sg-law.us
ATTORNEYS FOR PLAINTIFF
ATTORNEYS FOR PLAINTIFF
May 23, 30, 2014 14-02290S

SECOND INSERTION

NOTICE OF SALE
IN THE CIRCUIT COURT OF THE
TWELFTH JUDICIAL CIRCUIT, IN
AND FOR SARASOTA COUNTY,
FLORIDA
CASE NO.: 2013-CA-007940

CNLBank,
Plaintiff, vs.
MARC BEAULIEU and PAMELA
BEAULIEU, et al.
Defendants.

Notice is hereby given that, pursuant to a Final Judgment of Foreclosure entered in the above-styled cause, in the Circuit Court of Sarasota County, Florida, the Clerk of the Court will sell the property situated in Sarasota County, Florida, described as:

Unit No. 9 of Portofino of Venice, a Land Condominium according to The Declaration of Condominium recorded in Instrument #2005281485, and all exhibits and amendments thereof, and recorded in Condominium Book 38, Page 44, Public Records of Sarasota County, Florida.

at public sale, to the highest and best bidder, for cash, at 9:00 a.m. on the 27th day of June, 2014, via online sale at www.sarasota.realforeclose.com

ANY PERSON CLAIMING AN INTEREST IN THE SURPLUS FROM THE SALE, IF ANY, OTHER THAN THE PROPERTY OWNER AS OF THE DATE OF THE LIS PENDENS MUST FILE A CLAIM WITHIN 60 DAYS AFTER THE SALE PER SECTION 45.031, FLORIDA STATUTES.

If you are a person with a disability who needs any accommodation in order to participate in this proceeding, you are entitled, at no cost to you, to the provision of certain assistance. Please contact the Sarasota County Jury Office, P.O. Box 3079, Sarasota, Florida 34230-3079, (941)861-7400, at least seven (7) days before your scheduled court appearance, or immediately upon receiving this notification if the time before the scheduled appearance is less than seven (7) days; if you are hearing or voice impaired, call 711.

/s/ Douglas Gerber
August J. Stanton, III
Florida Bar No. 0976113
Douglas Gerber
Florida Bar No. 15269
STANTON & GASKICK, P.A.
390 N. Orange Avenue,
Suite 260
Orlando, Florida 32801
Ph. (407) 423-5203; Fax 425-4105
E-mail:
pleadings@sg-law.us/rmf@sg-law.us
ATTORNEYS FOR PLAINTIFF
ATTORNEYS FOR PLAINTIFF
May 23, 30, 2014 14-02304S

SECOND INSERTION

NOTICE TO CREDITORS
IN THE CIRCUIT COURT FOR
SARASOTA COUNTY, FLORIDA
PROBATE DIVISION
File No. 2014 CP 001980 NC
IN RE: ESTATE OF
IDA SCHUPPIN MILLER
a.k.a. IDA S. MILLER
a.k.a IDA GERTRUDE SCHUPPIN
MILLER
Deceased.

The administration of the estate of IDA SCHUPPIN MILLER a.k.a. IDA S. Miller a.k.a. IDA GERTRUDE SCHUPPIN MILLER, deceased, whose date of death was April 26, 2014, and whose social security number are xxx-xx-9738, is pending in the Circuit Court for SARASOTA County, Florida, Probate Division, the address of which is P. O. Box 3079, Sarasota, Florida 34230. The names and addresses of the personal representative and the personal representative's attorney are set forth below.

All creditors of the decedent and other persons having claims or demands against decedent's estate on whom a copy of this notice is required to be served must file their claims with this court WITHIN THE LATER OF 3 MONTHS AFTER THE TIME OF THE FIRST PUBLICATION OF THIS NOTICE OR 30 DAYS AFTER THE DATE OF SERVICE OF A COPY OF THIS NOTICE ON THEM.

All other creditors of the decedent and other persons having claims or demands against decedent's estate must file their claims with this court WITHIN 3 MONTHS AFTER THE DATE OF THE FIRST PUBLICATION OF THIS NOTICE.

ALL CLAIMS NOT FILED WITHIN THE TIME PERIODS SET FORTH IN SECTION 733.702 OF THE FLORIDA PROBATE CODE WILL BE FOREVER BARRED.

NOTWITHSTANDING THE TIME PERIOD SET FORTH ABOVE, ANY CLAIM FILED TWO (2) YEARS OR MORE AFTER THE DECEDENT'S DATE OF DEATH IS BARRED.

The date of first publication of this notice is May 23, 2014.

Personal Representative:

CHRISTOPHER L. MILLER
2409 Walker Circle
Sarasota, Florida 34234-7447
Attorney for Personal Representative:
R. CRAIG HARRISON, Esq.
E-Mail Address:
craig@lyonsbeaudryharrison.com
E-Mail Address:
ann@lyonsbeaudryharrison.com
Florida Bar No. 0466530
LYONS, BEAUDRY & HARRISON, P.A.
1605 Main Street, Suite 1111
Sarasota, Florida 34236
Telephone: (941) 366-3282
May 23, 30, 2014 14-02338S

HOW TO PUBLISH YOUR LEGAL NOTICE IN THE BUSINESS OBSERVER FOR MORE INFORMATION, CALL:
Hillsborough, Pasco (813) 221-9505
Pinellas (727) 447-7784
Manatee, Sarasota, Lee (941) 906-9386
Orange County (407) 654-5500
Collier (239) 263-0122
Charlotte (941) 249-4900
Or e-mail: legal@businessobserverfl.com

Business Observer
LV4658

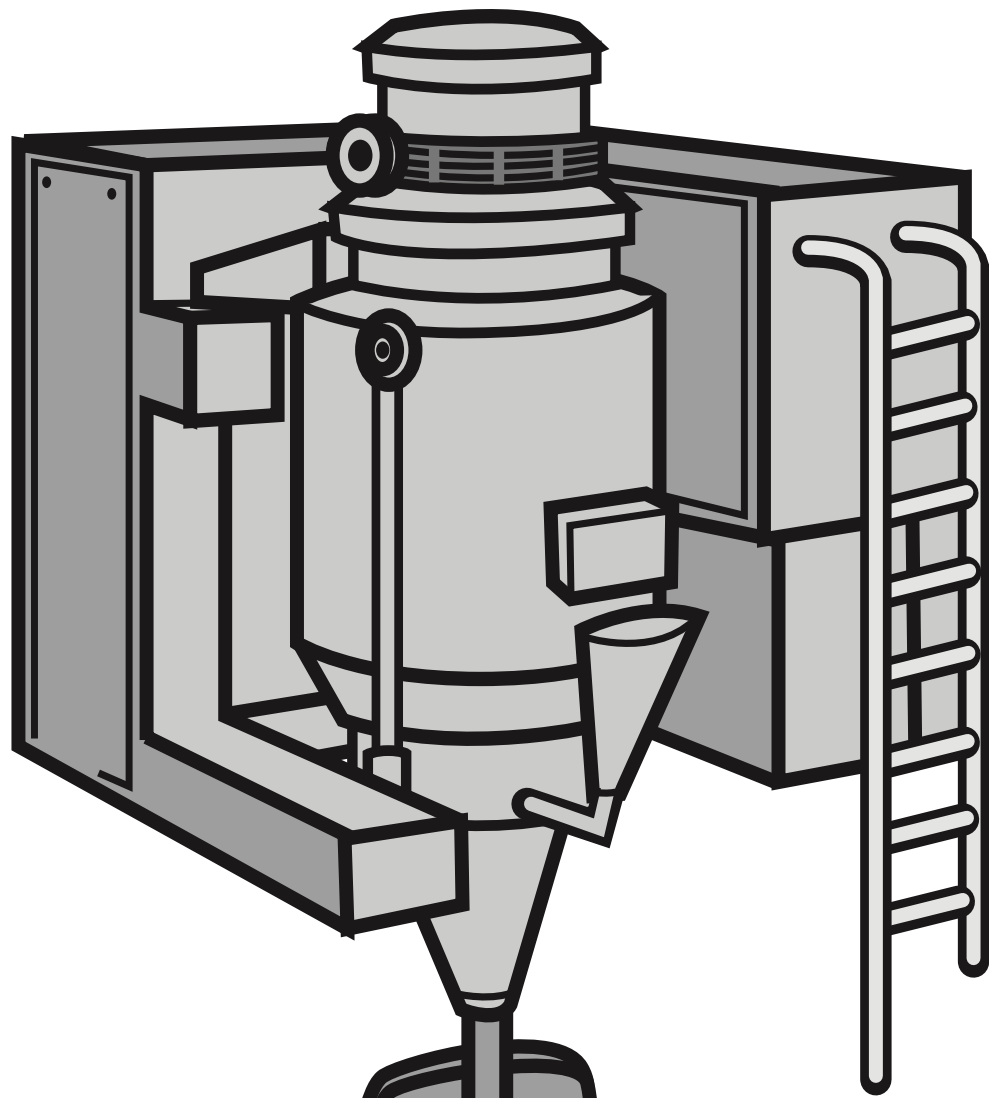

A special printing of
a classic story illustrating
the importance of
protecting capitalism.

TOM SMITH AND HIS INCREDIBLE BREAD MACHINE

By **R.W. Grant**

Illustrations by Austin McKinley

This is the legend of a man whose name
Was a household word: a man whose fame
Burst on the world like an atom bomb.
Smith was his last name; first name: Tom.

The argument goes on today.
"He was a villain," some will say.
"No! A hero!" others declare.
Or was he both? Well, I despair;
The fight will last 'til kingdom come;
Was Smith a hero? Or was Smith a bum?
So, listen to the story and it's up to you
To decide for yourself as to which is true!

Now, Smith, an inventor, had specialized
In toys. So people were surprised
When they found that he instead
Of making toys, was baking bread!
The news was flashed by CBS
Of his incredible success.
Then NBC jumped in in force,
Followed by the Times, of course.
The reason for their rapt attention,
The nature of his new invention,
The way to make bread he'd conceived
Cost less than people could believe!
And not just make it! This device
Could in addition wrap and slice!
The price per loaf, one loaf or many:
The miniscule sum of under one penny!

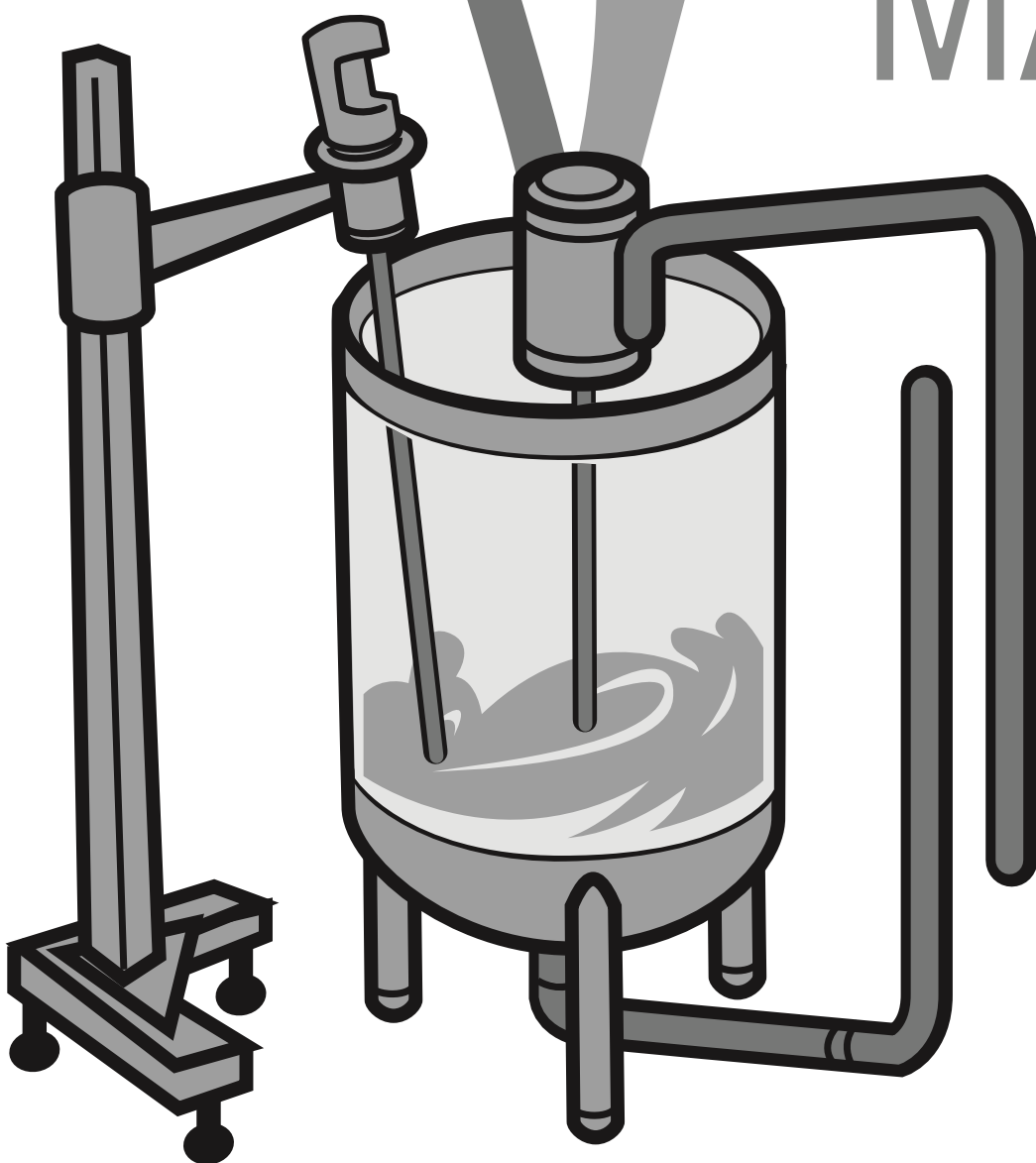

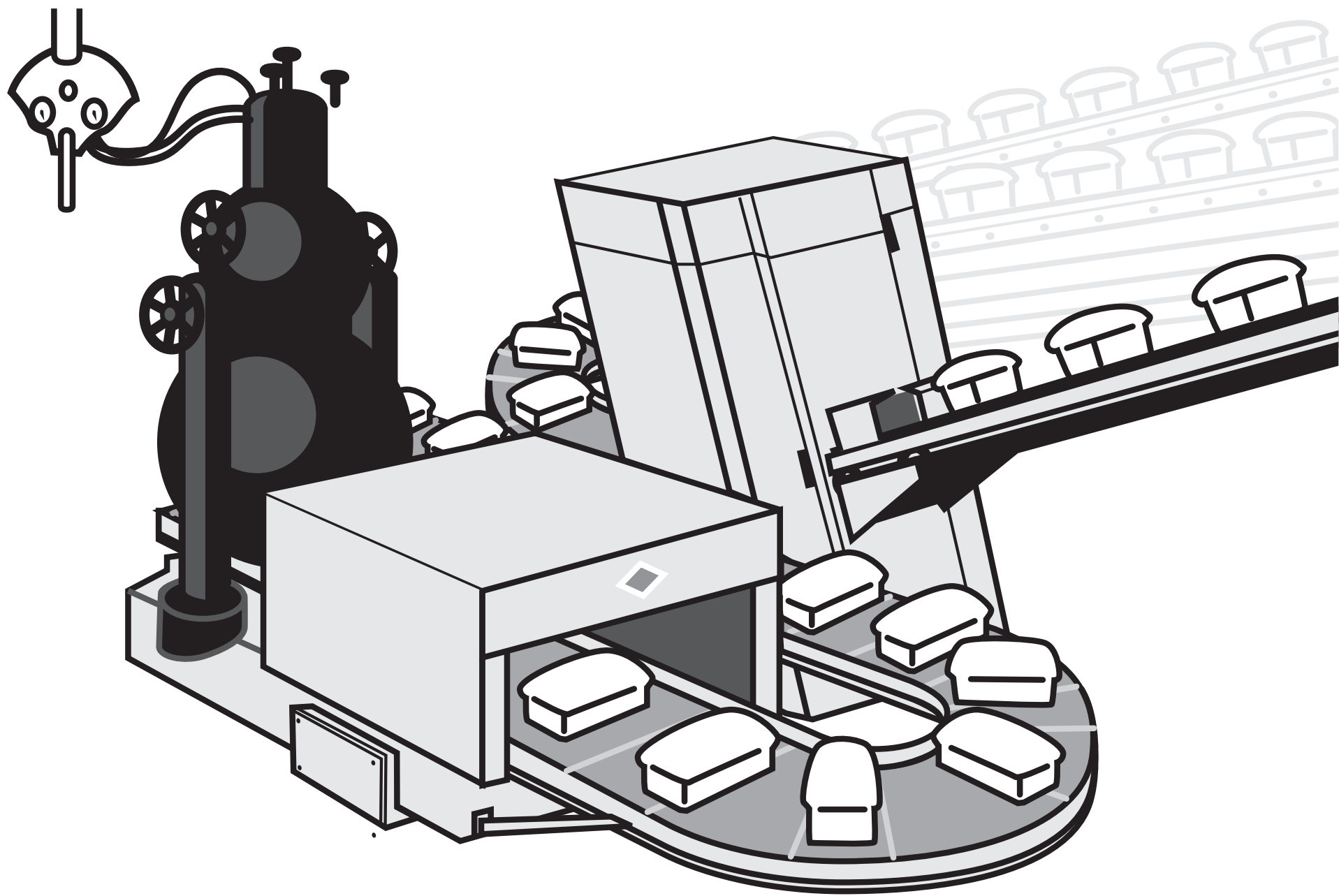

Can you imagine what this meant?
Can you comprehend the consequent?
The first time yet the world well fed!
And all because of Tom Smith's bread!

Not the last to see the repercussions
Were the Red Chinese, and, of course, the
Russians,
For Capitalist bread in such array

Threw the whole red block into black dis-
may!
Nonetheless, the world soon found
That bread was plentiful the world
around.
Thanks to Smith and all that bread,
A grateful world was at last well fed!

But isn't it a wondrous thing
How quickly fame is flown?
Smith, the hero of today
Tomorrow, scarcely known!
Yes, the fickle years passed by.
Smith was a billionaire.

But Smith himself was now forgot,
Though bread was everywhere.
People, asked from where it came,
Would very seldom know.

They would simply eat and ask,
'Was not it always so?'

However, Smith cared not a bit,
For millions ate his bread,
And "Everything is fine," thought he.
'I'm rich and they are fed!'

Everything was fine, he thought?
He reckoned not with fate.
Note the sequence of events
Starting on the date
On which inflation took its toll,
And to a slight extent,
The price on every loaf increased:
It went to one full cent!

A sharp reaction quickly came.
People were concerned.
White House aide expressed dismay.
Then the nation learned
That Russia lodged a sharp protest.
India did the same.
"Exploitation of the Poor!"
Yet, who was there to blame?

And though the clamor ebbed and flowed,
All that Tom would say
Was that it was but foolish talk.
Which soon would die away.
And it appeared that he was right.
Though on and on it ran,
The argument went 'round and 'round
But stopped where it began.

There it stopped, and people cried,
"For heaven's sake, we can't decide!
It's relative! Beyond dispute,
There's no such thing as 'absolute'!
And though we try with all our might,
Since nothing's ever black or white,
All that we can finally say is
'Everything one shade of grey is!'
So people cried out, "Give us light!
We can't tell what's wrong from right!"

To comprehend confusion,
We seek wisdom at its source.
To whom, then did the people turn?
The Intellectuals, of course!

And what could be a better time
For them to take the lead,
Than at their International Conference
On Inhumanity and Greed.
For at this weighty conference,
Once each year we face
The moral conscience of the world—
Concentrated in one place.

At that mighty conference were
A thousand, more or less,
Of intellectuals and bureaucrats,
And those who write the press.
And from Yale and Harvard
The professors; all aware
The fate of Smith would now be known.
Excitement filled the air!

"The time has come," the chairman said
"To speak of many things:
Of duty, bread and selfishness,
And the evil that it brings.
For, speaking thus we can amend
That irony of fate
That gives to unenlightened minds
The power to create.



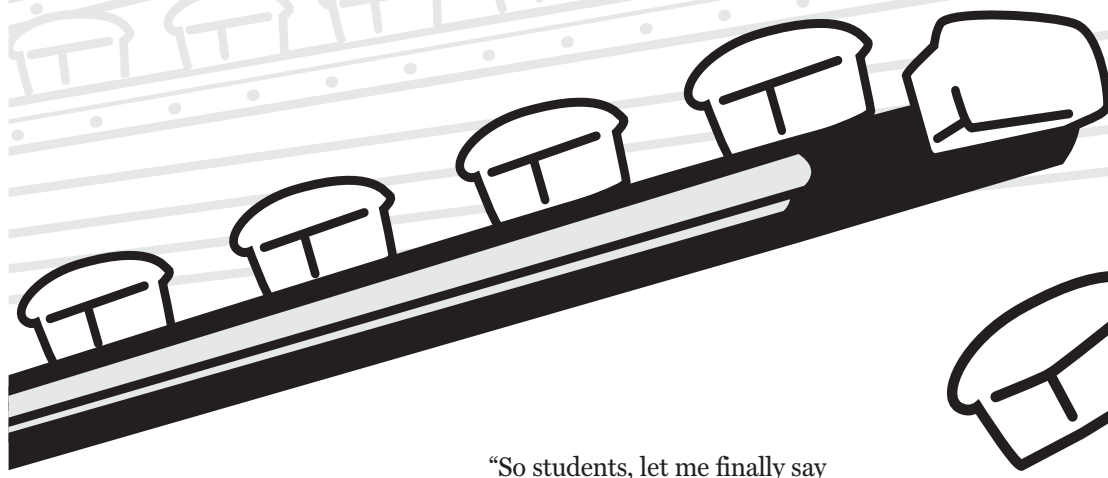

“Since reason tells us that it can’t,
Therefore let us start
Not by thinking with the mind,
But only with the heart!
Since we believe in people, then,”
At last the chairman said,
“We must meet our obligation
To see that they are fed!”

And so it went, one by one,
Denouncing private greed;
Denouncing those who’d profit thus
From other people’s need!

Then, suddenly each breath was held,
For there was none more wise
Than the nation’s foremost Pundit
Who now rose to summarize:

“My friends,” he said, (they all
exhaled)
“We see in these events
The flouting of the Higher Law—
And its consequence.
We must again remind ourselves
Just why mankind is cursed:
Because we fail to realize
Society comes first!”

“Smith placed himself above the
group
To profit from his brothers.
He failed to see the Greater Good,
Is Service, friends, to Others!”

With boldness and with vision,
then,
They ratified the motion
To dedicate to all mankind
Smith’s bread—and their devotion!

The conference finally ended.
It had been a huge success.
The intellectuals had spoken.
Now others did the rest.

The professors joined in all the
fuss,
And one was heard to lecture thus:
(For clarity, he spoke in terms
Of Mother Nature, birds and worms):

“That early birds should get the worm
Is clearly quite unfair.
Wouldn’t it much nicer be
If all of them would share?
But selfishness and private greed

Seem part of nature’s plan,
Which Mother Nature has decreed
For bird. But also Man?
The system which I question now,
As you are well aware,
(I’m sure you’ve heard the term
before
Is Business, Laissez-Faire!

“So students, let me finally say
That we must find a nobler way.
So, let us fix the race that all
May finish side-by-side;
The playing field forever flat,
The score forever tied.
To achieve this end, of course,
We turn to government—and force.
So, if we have to bring Smith do
As indeed we should,
I’m sure you will agree with me,
It’s for the Greater Good!”

Comments in the nation’s press
Now scorned Smith and his plunder:
“What right had he to get so rich
On other people’s hunger?”
A prize cartoon depicted Smith
With fat and drooping jowls
Snatching bread from hungry babes,
Indifferent to their howls.

One night, a TV star cried out,
“Forgive me if I stumble,
But I don’t think, I kid you not,
That Smith is very humble!”
Growing bolder, he leaped up,

(Silencing the cheers)
“Humility!” he cried to all—
And then collapsed in tears!

The clamor rises all about;
Now hear the politician shout:
“What’s Smith done, so rich to be?
Why should Smith have more than thee?
So, down with Smith and all his greed;
I’ll protect your right to need!”

Then Tom found to his dismay
That certain businessmen would say,
“The people now should realize
It’s time to cut Smith down to size,
For he’s betrayed his public trust
(And taken all that bread from us!)”

Well, since the Public does come first,
It could not be denied
That in matters such as this,
The public must decide.
So, SEC became concerned,
And told the press what it had learned:
“It’s obvious that he’s guilty
—Of what we’re not aware—
Though actually and factually
We’re sure there’s something there!”

And Antitrust now took a hand.
Of course it was appalled
At what it found was going on.
The “bread trust” it was called.

“Smith has too much crust,”
they said. “A deplorable condition
That Robber Barons profit thus
From cutthroat competition!”

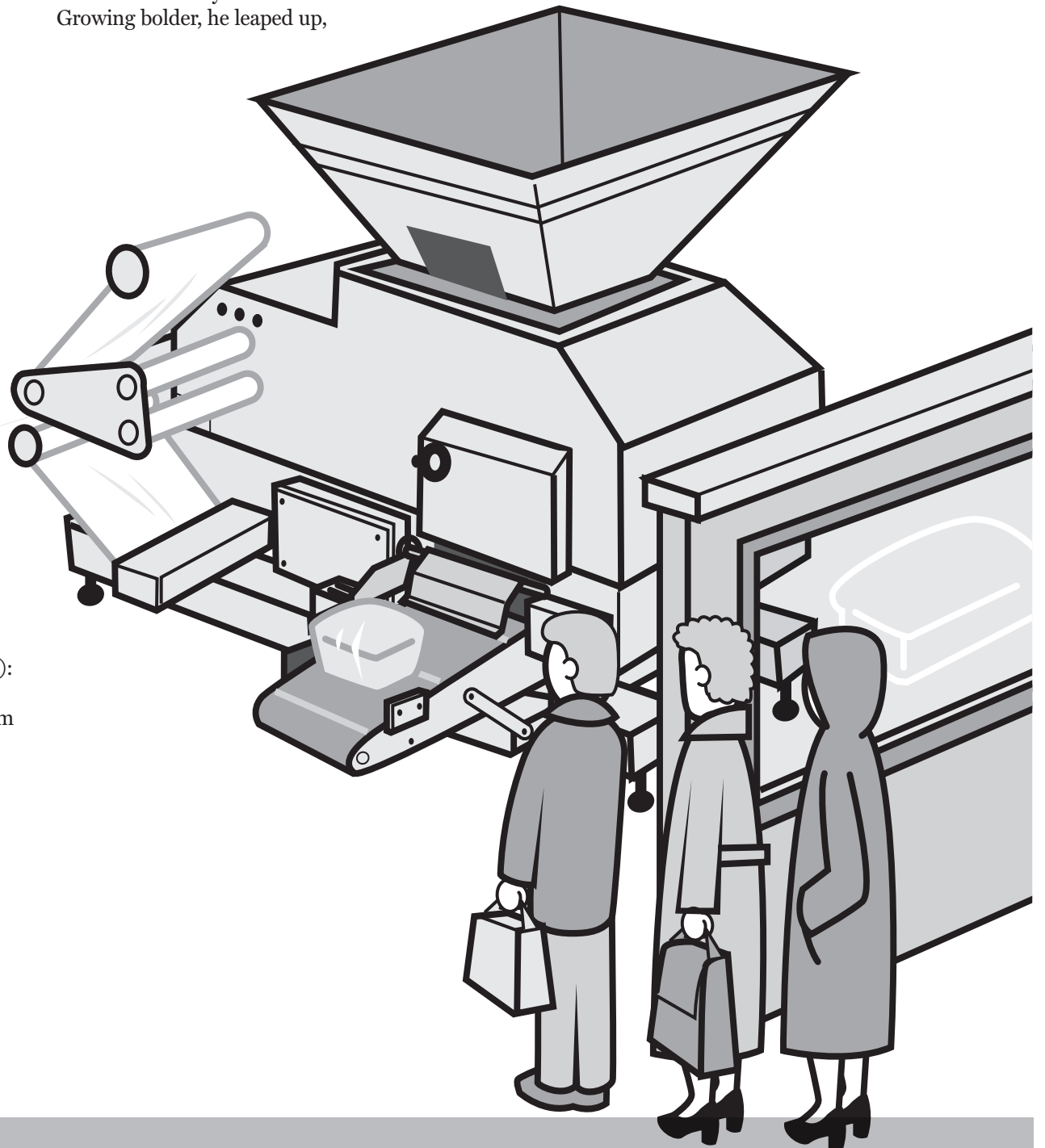

WELL!

This was getting serious!
So Smith felt that he must
Have a friendly interview
With SEC and 'Trust.
So, hat in hand, he went to them.
They'd surely been misled;
No rule of law had he defied.
But then their lawyer said:

"The rule of law, in complex times,
Has proved itself deficient.
We much prefer the rule of men.
It's vastly more efficient.

"So, nutshell-wise, the way it is,
The law is what we say it is!

"So, let me state the present rules,"
The lawyer then went on,
"These very simple guidelines
You can rely upon:
You're gouging on your prices
If you charge more than the rest.
But it's unfair competition
If you think you can charge less!
"A second point that we would make,
To help avoid confusion:
Don't try to charge the same amount,
For that would be collusion!

"You must compete—but not too much.
For if you do, you see,
Then the market would be yours—
And that's monopoly!
Oh, don't dare monopolize!
We'd raise an awful fuss,
For that's the greatest crime of all!
(Unless it's done by us!)"

"I think I understand," said Tom.
"And yet, before I go,
How does one get a job like yours?
I'd really like to know!"

The lawyer rose then with a smile;
"I'm glad you asked," said he.
"I'll tell you how I got my start
And how it came to be."

(His secretaries gathered 'round
As their boss did thus expound.)

*"When I was a lad going off to school,
I was always guided by this golden rule:
Let others take the lead in things, for
heaven's sake,
So if things go wrong—why, then it's their
mistake!"*
(*So if things go wrong—why, then it's their
mistake!*)

*"Following this precept it came to pass
I became the president of my senior class.
Then on to college where my profs extolled
The very same theory from the very same
mold!"*
(*The very same theory from the very same
mold!*)

*"Let others take the chances, and I would
go along.
Then I would let them know where they all
went wrong!
So successful was my system that then
indeed,
I was voted most likely in my class to suc-
ceed!"*

*(He was voted most likely in his class to
succeed!)*

*"Then out into the world I went, along
with all the rest,
Where I put my golden rule to the ulti-
mate test.
I avoided all of commerce at whatever the
cost—
And because I never ventured, then I also
never lost!"*
(*And because he never ventured, then he
also never lost!*)

*"With this unblemished record then, I
quickly caught the eye
Of some influential people 'mongst the
powers on high.*

*And so these many years among the
mighty I have sat,
Having found my niche as a bureaucrat!"*
(*Having found his niche as a bureaucrat*)

*"To be a merchant prince has never been
my goal,
For I'm qualified to play a more impor-
tant role:
Since I've never failed in business, this of
course assures
That I'm qualified beyond dispute to now
run yours!"*
(*That he's qualified beyond dispute to now
run yours!*)

"Thanks; that clears it up," said Tom.

The lawyer said, "I'm glad!
We try to serve the public good.
We're really not so bad!

"Now, in disposing of this case,
If you wish to know just how,
Go up to the seventh floor;
We're finalizing now!"

So, Tom went to the conference room
Up on the seventh floor.
He raised his hand, about to knock,
He raised it—but no more—
For what he overheard within
Kept him outside the door!
A sentence here, a sentence there—
Every other word—
He couldn't make it out (he hoped),
For this is what he heard:

"Mumble, mumble, let's not fumble!
Mumble, mumble, what's the charge?
Grumble, grumble, he's not humble?
Private greed? Or good of all?"

"Public Interest, Rah! Rah! Rah!
Business, Business, Bah! Bah! Bah!

"Say, now this now we confess
That now this now is a mess!
Well now, what now do we guess?
Discharge? Which charge would be best?"

"How 'bout 'Greed and Selfishness'?
Oh, wouldn't that be fun?
It's vague enough to trip him up
No matter what he's done!

"We don't produce or build a thing!
But before we're through,
We allow that now we'll show Smith how
We handle those who do!

"We serve the public interest;
We make up our own laws;
Oh, golly gee, how selflessly
We serve the public cause!

"For we're the ones who make the rules
At 'Trust and SEC,
So bye and bye we'll get that guy;
Now, what charge will it be?"

"Price too high? Or price too low?
Now, which charge will we make?
Well, we're not loath to charging both
When public good's at stake!

"But can we go one better?
How 'bout monopoly?
No muss, no fuss, oh clever us!
Right-O! Let's charge all three!"

"But why stop here? We have one more!
Insider Trading! Number four!
We've not troubled to define
This crime in any way so,
This allows the courts to find
Him guilty 'cause we say so!"

So, that was the indictment.
Smith's trial soon began.
It was a cause célèbre
Which was followed' cross the land.
In his defense Tom only said,
"I'm rich, but all of you are fed!
Is that bargain so unjust
That I should now be punished thus?"

Tom fought it hard all the way.
But it didn't help him win.
The jury took but half an hour
To bring this verdict in:

"Guilty! Guilty! We agree!
He's guilty of this plunder!
He had no right to get so rich
On other people's hunger!"

"Five years in jail!" the judge then said.
"You're lucky it's not worse!
Robber Barons must be taught
Society Comes First!
As flies to wanton boys," he leered,
"Are we to men like these!
They exploit us for their sport!
Exploit us as they please!"

The sentence seemed a bit severe,
But mercy was extended.
In deference to his mother's pleas,
One year was suspended.
And what about the Bread Machine?
Tom Smith's little friend?
Broken up and sold for scrap.
Some win. Some lose. The end.

EPILOGUE

Now, bread is baked by government.
And as might be expected,
Everything is well controlled—
The public well protected.

True, loaves cost ten dollars each.
But our leaders do their best.
The selling price is half a cent.
Taxes pay the rest!

