

PASCO COUNTY LEGAL NOTICES

--- PUBLIC NOTICES ---

FIRST INSERTION

Notice of Public Hearing and Board of Supervisors Meeting of the Acacia Fields Community Development District

The Board of Supervisors (the "Board") of the Acacia Fields Community Development District (the "District") will hold a public hearing and regular meeting on Tuesday, July 14, 2026, at 9:00 a.m. at the Hilton Garden Inn Tampa Suncoast Parkway located at 2155 Northpointe Parkway, Lutz, Florida 33558.

The purpose of the public hearing is to receive public comments on the proposed adoption of the District's fiscal year 2026-2027 proposed budget. A meeting of the Board will also be held where the Board may consider any other business that may properly come before it. A copy of the proposed budget and the agenda may be viewed on the District's website at <https://www.acaciafieldsccd.org/> at least two days before the meeting or may be obtained by contacting the District Manager's office via email at sbrizendine@rizzetta.com or via phone at (813) 933-5571.

The public hearing and meeting are open to the public and will be conducted in accordance with the provisions of Florida law for community development districts. They may be continued to a date, time, and place to be specified on the record at the hearing or meeting. There may be occasions when staff or Board members may participate by speaker telephone.

In accordance with the provisions of the Americans with Disabilities Act, any person requiring special accommodations because of a disability or physical impairment should contact the District Manager's office at least 48 hours prior to the meeting. If you are hearing or speech impaired, please contact the Florida Relay Service at 711 or 1-800-955-8771 (TTY), or 1-800-955-8770 (voice) for aid in contacting the District Manager's office.

Each person who decides to appeal any decision made by the Board with respect to any matter considered at the public hearing or meeting is advised that person will need a record of proceedings and that accordingly, the person may need to ensure that a verbatim record of the proceedings is made, including the testimony and evidence upon which such appeal is to be based.

Scott Brizendine
District Manager
June 12, 19, 2026 26-01325P

FIRST INSERTION

Notice of Public Hearing and Board of Supervisors Meeting of the Copperspring Community Development District

The Board of Supervisors (the "Board") of the Copperspring Community Development District (the "District") will hold a public hearing and a regular meeting on Tuesday, July 14, 2026, at 11:00 a.m. at the Hilton Garden Inn Tampa Suncoast Parkway located at 2155 Northpointe Parkway Lutz, FL 33558.

The purpose of the public hearing is to receive public comments on the proposed adoption of the District's fiscal year 2026-2027 proposed budget. A meeting of the Board will also be held where the Board may consider any other business that may properly come before it. A copy of the proposed budget and the agenda may be viewed on the District's website at www.copperspringcdd.org, or may be obtained by contacting the District Manager's office via email at srafft@rizzetta.com or via phone at (813) 933-5571.

The public hearing and meeting are open to the public and will be conducted in accordance with the provisions of Florida law for community development districts. They may be continued to a date, time, and place to be specified on the record at the hearing or meeting. There may be occasions when staff or Board members may participate by speaker telephone.

In accordance with the provisions of the Americans with Disabilities Act, any person requiring special accommodations because of a disability or physical impairment should contact the District Manager's office at least 48 hours prior to the meeting. If you are hearing or speech impaired, please contact the Florida Relay Service at 711 or 1-800-955-8771 (TTY), or 1-800-955-8770 (voice) for aid in contacting the District Manager's office.

Each person who decides to appeal any decision made by the Board with respect to any matter considered at the public hearing or meeting is advised that person will need a record of proceedings and that accordingly, the person may need to ensure that a verbatim record of the proceedings is made, including the testimony and evidence upon which such appeal is to be based.

Sean Craft
District Manager
June 12, 19, 2026 26-01326P

FIRST INSERTION

Notice of Public Hearing and Board of Supervisors Meeting of the SageBrush Community Development District

The Board of Supervisors (the "Board") of the SageBrush Community Development District (the "District") will hold a public hearing and regular meeting on Tuesday, July 14, 2026, at 9:00 a.m. at the Hilton Garden Inn Tampa Suncoast Parkway located at 2155 Northpointe Parkway, Lutz, Florida 33558.

The purpose of the public hearing is to receive public comments on the proposed adoption of the District's fiscal year 2026-2027 proposed budget. A meeting of the Board will also be held where the Board may consider any other business that may properly come before it. A copy of the proposed budget and the agenda may be viewed on the District's website at <https://www.sagebrushcdd.org/> at least two days before the meeting or may be obtained by contacting the District Manager's office via email at sbrizendine@rizzetta.com or via phone at (813) 933-5571.

The public hearing and meeting are open to the public and will be conducted in accordance with the provisions of Florida law for community development districts. They may be continued to a date, time, and place to be specified on the record at the hearing or meeting. There may be occasions when staff or Board members may participate by speaker telephone.

In accordance with the provisions of the Americans with Disabilities Act, any person requiring special accommodations because of a disability or physical impairment should contact the District Manager's office at least 48 hours prior to the meeting. If you are hearing or speech impaired, please contact the Florida Relay Service at 711 or 1-800-955-8771 (TTY), or 1-800-955-8770 (voice) for aid in contacting the District Manager's office.

Each person who decides to appeal any decision made by the Board with respect to any matter considered at the public hearing or meeting is advised that person will need a record of proceedings and that accordingly, the person may need to ensure that a verbatim record of the proceedings is made, including the testimony and evidence upon which such appeal is to be based.

Scott Brizendine
District Manager
June 12, 19, 2026 26-01328P

FIRST INSERTION

Notice of Public Hearing and Board of Supervisors Meeting of the Mitchell Ranch Community Development District

The Board of Supervisors (the "Board") of the Mitchell Ranch Community Development District (the "District") will hold a public hearing and a regular meeting on Tuesday, July 14, 2026, at 10:00 a.m. at the Hilton Garden Inn Tampa Suncoast Parkway located at 2155 Northpointe Parkway Lutz, FL 33558.

The purpose of the public hearing is to receive public comments on the proposed adoption of the District's fiscal year 2026-2027 proposed budget and the proposed levy of its annually recurring non-ad valorem special assessments for operation and maintenance to fund the items described in the proposed budget (the "O&M Assessments").

At the conclusion of the public hearing, the Board will, by resolution, adopt a final budget, provide for the levy, collection, and enforcement of the O&M Assessments, and certify an assessment roll. A meeting of the Board will also be held where the Board may consider any other business that may properly come before it.

A copy of the proposed budget, preliminary assessment roll, and the agenda may be viewed on the District's website at www.mitchellranchcdd.org at least two (2) days before the meeting, or may be obtained by contacting the District Manager's office via email at srafft@rizzetta.com or via phone at (813) 994-1001.

The table below presents the proposed schedule of the O&M Assessments. Amounts are preliminary and subject to change at the meeting and in any future year.

Total O&M Budget	\$736,388.00
Collection Costs @ 2.0%	\$ 15,667.83
Early Payment Discount @ 4.0%	\$ 31,335.66
Total O&M Assessment	\$783,391.49

Lot Size	Units	O&M Per Lot
Platted Townhomes 18'	254	\$ 868.50
Platted Townhomes 28'	168	\$ 868.50
Platted Single Family 40'	94	\$1,737.01
Platted Single Family 50'	146	\$1,737.01

The O&M Assessments (in addition to debt assessments, if any) will appear on the November 2026 property tax bill. The amount shown above includes all applicable collection costs. The property owner is eligible for a discount of up to 4% if paid early.

The County Tax Collector will collect the assessments for all lots and parcels within the District. Alternatively, the District may elect to directly collect its assessments in accordance with Chapter 190, Florida Statutes. Failure to pay the District's assessments will cause a tax certificate to be issued against the property which may result in a loss of title or a foreclosure action to be filed against the property. All affected property owners have the right to appear at the public hearing and to file written objections with the District within 20 days of publication of this notice.

The public hearing and meeting are open to the public and will be conducted in accordance with the provisions of Florida law for community development districts. They may be continued to a date, time, and place to be specified on the record at the hearing or meeting. There may be occasions when staff or Board members may participate by speaker telephone.

In accordance with the provisions of the Americans with Disabilities Act, any person requiring special accommodations because of a disability or physical impairment should contact the District Manager's office at least two (2) business days prior to the meeting. If you are hearing or speech impaired, please contact the Florida Relay Service at 711 or 1-800-955-8771 (TTY), or 1-800-955-8770 (voice) for aid in contacting the District Manager's office.

Each person who decides to appeal any decision made by the Board with respect to any matter considered at the public hearing or meeting is advised that person will need a record of proceedings and that accordingly, the person may need to ensure that a verbatim record of the proceedings is made, including the testimony and evidence upon which such appeal is to be based.

Sean Craft
District Manager

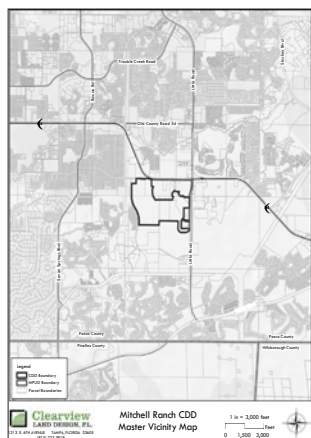

June 12, 2026 26-01327P

FIRST INSERTION

NOTICE OF RULE DEVELOPMENT BY THE KD52 COMMUNITY DEVELOPMENT DISTRICT NO. 1

In accordance with Chapters 120 and 190, Florida Statutes, the KD52 Community Development District No. 1 ("District") hereby gives notice of its intention to develop revised Rules of Procedure to govern the operations of the District. The proposed rule number is ROP-2026-1.

The revised Rules of Procedure will address such areas as the Board of Supervisors, officers and voting, district offices, public information and inspection of records, policies, public meetings, hearings and workshops, rulemaking proceedings, competitive purchase including procedure under the Consultants' Competitive Negotiation Act, procedure regarding auditor selection, purchase of insurance, pre-qualification, construction contracts, goods, supplies and materials, maintenance services, contractual services and protests with respect to proceedings, as well as any other area of the general operation of the District.

The purpose and effect of the revised Rules of Procedure is to provide for efficient and effective District operations and to ensure compliance with recent changes to Florida law. The specific grant of rulemaking authority for the adoption of the proposed revised Rules of Procedure includes Sections 190.011(5), 190.011(15) and 190.035, Florida Statutes. The specific laws implemented in the proposed revised Rules of Procedure include, but are not limited to, Sections 112.08, 112.3143, 112.31446, 112.3145, 119.07, 119.0701, 120.54, 120.542, 120.5435, 120.56, 120.69, 120.81, 189.053, 189.069, 190.006, 190.007, 190.008, 190.011, 190.033, 190.035, 218.33, 218.391, 255.05, 255.0518, 255.0525, 255.20, 286.0105, 286.011, 286.012, 286.0113, 286.0114, 287.017, 287.055, and 287.084, Florida Statutes.

A copy of the proposed revised Rules of Procedure and the related incorporated documents, if any, may be obtained by contacting the District Manager, c/o Wrathell, Hunt and Associates, LLC, 2300 Glades Road, Suite 410W, Boca Raton, Florida 33431, (561) 571-0010 (the "District Manager's Office").

Cindy Cerbone, District Manager
KD52 Community Development District No. 1
June 12, 2026 26-01340P

FIRST INSERTION

NOTICE OF RULE DEVELOPMENT BY THE KD52 COMMUNITY DEVELOPMENT DISTRICT NO. 2

In accordance with Chapters 120 and 190, Florida Statutes, the KD52 Community Development District No. 2 ("District") hereby gives notice of its intention to develop revised Rules of Procedure to govern the operations of the District. The proposed rule number is ROP-2026-1.

The revised Rules of Procedure will address such areas as the Board of Supervisors, officers and voting, district offices, public information and inspection of records, policies, public meetings, hearings and workshops, rulemaking proceedings, competitive purchase including procedure under the Consultants' Competitive Negotiation Act, procedure regarding auditor selection, purchase of insurance, pre-qualification, construction contracts, goods, supplies and materials, maintenance services, contractual services and protests with respect to proceedings, as well as any other area of the general operation of the District.

The purpose and effect of the revised Rules of Procedure is to provide for efficient and effective District operations and to ensure compliance with recent changes to Florida law. The specific grant of rulemaking authority for the adoption of the proposed revised Rules of Procedure includes Sections 190.011(5), 190.011(15) and 190.035, Florida Statutes. The specific laws implemented in the proposed revised Rules of Procedure include, but are not limited to, Sections 112.08, 112.3143, 112.31446, 112.3145, 119.07, 119.0701, 120.54, 120.542, 120.5435, 120.56, 120.69, 120.81, 189.053, 189.069, 190.006, 190.007, 190.008, 190.011, 190.033, 190.035, 218.33, 218.391, 255.05, 255.0518, 255.0525, 255.20, 286.0105, 286.011, 286.012, 286.0113, 286.0114, 287.017, 287.055, and 287.084, Florida Statutes.

A copy of the proposed revised Rules of Procedure and the related incorporated documents, if any, may be obtained by contacting the District Manager, c/o Wrathell, Hunt and Associates, LLC, 2300 Glades Road, Suite 410W, Boca Raton, Florida 33431, (561) 571-0010 (the "District Manager's Office").

Cindy Cerbone, District Manager
KD52 Community Development District No. 2
June 12, 2026 26-01341P

FIRST INSERTION

Notice Under Fictitious Name Law According to Florida Statute Number 865.09

NOTICE IS HEREBY GIVEN that the undersigned, desiring to engage in business under the Fictitious Name of Price Hero located at 16497 Acoustic Loop in the City of Land O Lakes, Pasco, FL 34638 intends to register the said name with the Division of Corporations of the Department of State, Tallahassee, Florida.

Dated this 10th day of June, 2026
Trendful Inc
Jacquelyn de la Parte
June 12, 2026 26-01359P

FIRST INSERTION

Notice Under Fictitious Name Law According to Florida Statute Number 865.09

NOTICE IS HEREBY GIVEN that the undersigned, desiring to engage in business under the Fictitious Name of KEVIN'S ROBOTS located at 3348 Wilson Dr in the City of Holiday, Pasco, FL 34691 intends to register the said name with the Division of Corporations of the Department of State, Tallahassee, Florida.

Dated this 8th day of June, 2026
Kevin Kenneally
June 12, 2026 26-01347P

FIRST INSERTION

NOTICE UNDER FICTITIOUS NAME LAW

Pursuant to F.S. §865.09 NOTICE IS HEREBY GIVEN that the undersigned, desiring to engage in business under the fictitious name of Tang Co, located at 2725 Meadowood Dr, in the City of New Port Richey, County of Pasco, State of FL, 34655, intends to register the said name with the Division of Corporations of the Florida Department of State, Tallahassee, Florida.

Dated this 4 of June, 2026.
Tang LLC
2725 Meadowood Dr
New Port Richey, FL 34655
June 12, 2026 26-01329P

FIRST INSERTION

Notice Under Fictitious Name Law According to Florida Statute Number 865.09

NOTICE IS HEREBY GIVEN that the undersigned, desiring to engage in business under the Fictitious Name of Law Office of Steve Williams & Associates located at 10820 State Road 54 Suite 202 in the City of Trinity, Pasco, FL 34655 intends to register the said name with the Division of Corporations of the Department of State, Tallahassee, Florida.

Dated this 5th day of June, 2026
Stephen R Williams
June 12, 2026 26-01337P

FIRST INSERTION

Notice Under Fictitious Name Law According to Florida Statute Number 865.09

NOTICE IS HEREBY GIVEN that the undersigned, desiring to engage in business under the Fictitious Name of Vintage and Vital located at 8350 Eagle Brook Drive in the City of Land O' Lakes, Pasco, FL 34638-2705 intends to register the said name with the Division of Corporations of the Department of State, Tallahassee, Florida.

Dated this 7th day of June, 2026
Kristie Wheeltey
June 12, 2026 25-01343P

FIRST INSERTION

Notice Under Fictitious Name Law According to Florida Statute Number 865.09

NOTICE IS HEREBY GIVEN that the undersigned, desiring to engage in business under the Fictitious Name of PET URGENT CARE OF WESLEY CHAPEL located at 27027 STATE ROAD 56 in the City of WESLEY CHAPEL, Pasco, FL 33544 intends to register the said name with the Division of Corporations of the Department of State, Tallahassee, Florida.

Dated this 27th day of May, 2026
PET URGENT CARE OF WESLEY CHAPEL, LLC
Sreenivas Kanuganti
June 12, 2026 26-01330P

FIRST INSERTION

NOTICE OF PUBLIC SALE: NOTICE IS HEREBY GIVEN THAT ON 07/06/2026 AT 08:00 AM THE FOLLOWING VEHICLES(S) MAY BE SOLD AT PUBLIC SALE PURSUANT TO FLORIDA STATUTE 713. 585. NAME: R & R AUTOWORXS, INC 1GCHK24U85E315774 2005 CHEV 6239.00 TEL:813-697-1791 MV#: MV82225 LOCATION: 8030 MASSACHUSETTS AVE, NEW PORT RICHEY, FL 34653/

June 12, 2026 26-01336P

FIRST INSERTION

Fictitious Name Notice

Notice is hereby given that Ober Ventures LLC, owner, desiring to engage in business under the fictitious name of Meridian Pool Service located at 13756 Wineberry Drive, Dade City, Florida 33525 intends to register the said name in Pasco county with the Division of Corporations, Florida Department of State, pursuant to section 865.09 of the Florida Statutes.

June 12, 2026 26-01342P

FIRST INSERTION

NOTICE TO CREDITORS

RE: BERTHA W. DIXON, Deceased
TO: ALL PERSONS HAVING CLAIMS OR DEMANDS AGAINST THE ABOVE NAMED DECEDENT

The above-named Decedent, established a Living Trust, entitled BERTHA W. DIXON LIVING TRUST, dated APRIL 30, 2007, died on MAY 18, 2026. The name(s) and address(es) of the Trustee(s) is/are set forth below.

ALL INTERESTED PERSONS ARE NOTIFIED THAT:

All creditors of the decedent and other persons having claims or demands against decedent's Trust (and/or estate) must file their claims with the Trustee listed below WITHIN THREE MONTHS AFTER THE DATE OF THE FIRST PUBLICATION OF THIS NOTICE.

ALL CLAIMS AND DEMANDS NOT SO FILED WILL BE FOREVER BARRED.

The date of first publication of this Notice is June 12, 2026.
DALE A. DUBY, TRUSTEE
24 Beach Rd.
East Haddam, CT 06423

June 12, 19, 2026 26-01324P

PUBLISH YOUR LEGAL NOTICE
Call 941-906-9386
or email legal@businessobserverfl.com

--- ESTATE ---

FIRST INSERTION

NOTICE TO CREDITORS
(Intestate)

IN THE CIRCUIT COURT FOR THE SIXTH JUDICIAL CIRCUIT IN AND FOR PASCO COUNTY, FLORIDA PROBATE DIVISION
Case No. 2026CP000872CPAXES
IN RE: ESTATE OF JOHN PHILIP MCQUISTON SR, Decedent.

The administration of the Estate of John Philip McQuiston Sr, Deceased, whose date of death was March 22, 2026; Case Number 2026CP000872CPAXES, is pending in the Circuit Court for Pasco County, Florida, Probate Division, the address of which is PO Box 338, New Port Richey, Florida 34656-0338. The name and address of the Personal Representative are John P. McQuiston Jr, 10913 Johanna Avenue, Riverview, FL 33578, and the name and address of the Personal Representative's attorney are set forth below.

All creditors of the Decedent and other persons having claims or demands against Decedent's Estate, including unmaturing, contingent or unliquidated claims, on whom a copy of this notice is served must file their claims with this Court WITHIN THE LATER OF THREE (3) MONTHS AFTER THE DATE OF THE FIRST PUBLICATION OF THIS NOTICE OR THIRTY (30) DAYS AFTER THE DATE OF SERVICE OF A COPY OF THIS NOTICE ON THEM.

All other creditors of the Decedent and persons having claims or demands against the Decedent's Estate, including unmaturing, contingent or unliquidated claims, must file their claims with this court WITHIN THREE (3) MONTHS AFTER THE DATE OF THE FIRST PUBLICATION OF THIS NOTICE.

ALL CLAIMS, DEMANDS AND OBJECTIONS NOT SO FILED WILL BE FOREVER BARRED.

NOTWITHSTANDING THE TIME PERIODS SET FORTH ABOVE, ANY CLAIM FILED TWO (2) YEARS OR MORE AFTER THE DECEDENT'S DATE OF DEATH IS BARRED.

The personal representative or curator has no duty to discover whether any property held at the time of the Decedent's death by the Decedent or the Decedent's surviving spouse is property to which the Florida Uniform Disposition of Community Property Rights at Death Act as described in sections 732.216-732.228, Florida Statutes, applies, or may apply, unless a written demand is made by a creditor as specified under section 732.221, Florida Statutes.

The date of the first publication of this Notice is June 12, 2026.
CARR LAW GROUP, P.A.
 Lee R. Carr, II, Esquire
 200 Central Avenue, Suite 400
 St. Petersburg, FL 33701
 Voice: 727-894-7000;
 Fax: 727-821-4042
 Primary email address:
 lcarr@carlawgroup.com
 Secondary email address:
 pcardinal@carlawgroup.com
 June 12, 19, 2026 26-01323P

FIRST INSERTION

NOTICE TO CREDITORS
 IN THE CIRCUIT COURT FOR PASCO COUNTY, FLORIDA
 PROBATE DIVISION
File No.: 2026CP000770CPAXES
IN RE: ESTATE OF PATRICK GEORGE, Deceased.

The administration of the estate of Patrick George, deceased, whose date of death was November 2, 2025, is pending in the Circuit Court for Pasco County, Florida, Probate Division, the mailing address of which is P.O. Box 338, New Port Richey, FL 34656-0338. The names and addresses of the personal representative and the personal representative's attorney are set forth below.

All creditors of the decedent and other persons having claims or demands against decedent's estate on whom a copy of this notice is required to be served must file their claims with this court ON OR BEFORE THE LATER OF 3 MONTHS AFTER THE TIME OF THE FIRST PUBLICATION OF THIS NOTICE OR 30 DAYS AFTER THE DATE OF SERVICE OF A COPY OF THIS NOTICE ON THEM.

All other creditors of the decedent and other persons having claims or demands against decedent's estate must file their claims with this court WITHIN 3 MONTHS AFTER THE DATE OF THE FIRST PUBLICATION OF THIS NOTICE.

The personal representative has no duty to discover whether any property held at the time of the decedent's death by the decedent or the decedent's surviving spouse is property to which the Florida Uniform Disposition of Community Property Rights at Death Act as described in ss. 732.216-732.228, Florida Statutes, applies, or may apply, unless a written demand is made by a creditor as specified under s. 732.221, Florida Statutes. The written demand must be filed with the clerk.

ALL CLAIMS NOT FILED WITHIN THE TIME PERIODS SET FORTH IN FLORIDA STATUTES SECTION 733.702 WILL BE FOREVER BARRED.

NOTWITHSTANDING THE TIME PERIODS SET FORTH ABOVE, ANY CLAIM FILED TWO (2) YEARS OR MORE AFTER THE DECEDENT'S DATE OF DEATH IS BARRED.

The date of first publication of this notice is June 12, 2026.

Personal Representative:
Sean Montgomery
 17605 Overstreet Lane
 Spring Hill, Florida 34610

Attorney for Personal Representative:
 Kenneth J. Crotty
 Florida Bar Number: 016476
 Hill Ward Henderson
 101 E. Kennedy Boulevard,
 Suite 3700
 Tampa, FL 33602
 Telephone: (813) 221-3900
 Fax: (813) 221-2900
 E-Mail: ken.crotty@hwlaw.com
 Secondary: probate.efile@hwlaw.com
 June 12, 19, 2026 26-01339P

FIRST INSERTION

NOTICE TO CREDITORS
 IN THE SIXTH JUDICIAL CIRCUIT, IN AND FOR PASCO COUNTY, FLORIDA
 PROBATE DIVISION
File No. 2025-CP-001307
IN RE: ESTATE OF JONATHAN DONDORFER, Deceased.

The administration of the estate of JONATHAN DONDORFER, deceased, whose date of death was JUNE 28, 2025, is pending in the Circuit Court for PASCO County, Florida, Probate Division, the address of which is 7530 Little Road, Suite 105, New Port Richey, FL 34654. The names and addresses of the personal representative and the personal representative's attorney are set forth below.

All creditors of the decedent and other persons having claims or demands against decedent's estate, on whom a copy of this notice is required to be served, must file their claims with this court ON OR BEFORE THE LATER OF 3 MONTHS AFTER THE TIME OF THE FIRST PUBLICATION OF THIS NOTICE OR 30 DAYS AFTER THE DATE OF SERVICE OF A COPY OF THIS NOTICE ON THEM.

All other creditors of the decedent and other persons having claims or demands against decedent's estate must file their claims with this court WITHIN 3 MONTHS AFTER THE DATE OF THE FIRST PUBLICATION OF THIS NOTICE.

ALL CLAIMS NOT FILED WITHIN THE TIME PERIODS SET FORTH IN FLORIDA STATUTES SECTION 733.702 WILL BE FOREVER BARRED.

NOTWITHSTANDING THE TIME PERIOD SET FORTH ABOVE, ANY CLAIM FILED TWO (2) YEARS OR MORE AFTER THE DECEDENT'S DATE OF DEATH IS BARRED.

A Personal Representative or curator has no duty to discover whether any property held at the time of the decedent's death by the decedent or the decedent's surviving spouse is property to which the Florida Uniform Disposition of Community Property Rights at Death Act as described in ss. 732.216-732.228, applies, or may apply, unless a written demand is made by a creditor as specified under s. 732.221.

The date of first publication of this notice is June 12, 2026.

MICHAEL DONDORFER
Personal Representative

7721 Birchwood Dr.
 Port Richey, FL 34668
MATTHEW MCCONNELL, Esq.
 Florida Bar No. 126161
 Attorney for Personal Representative
 Dickman Law Firm
 Post Office Box 111868
 Naples, FL 34108
 T: 239-434-0840 - F: 239-434-0940
 matthew@dickmanlawfirm.org
 June 12, 19, 2026 26-01335P

FIRST INSERTION

NOTICE TO CREDITORS
 IN THE CIRCUIT COURT FOR PASCO COUNTY, FLORIDA
 PROBATE DIVISION
File No. 2026-CP-000868
IN RE: ESTATE OF KIMBERLY FITZGIBBON, Deceased.

The administration of the estate of KIMBERLY FITZGIBBON, deceased, whose date of death was October 20, 2024, is pending in the Circuit Court for Pasco County, Florida, Probate Division, the address of which is 7530 Little Road New Port Richey, FL 34654. The names and addresses of the personal representative and the personal representative's attorney are set forth below.

All creditors of the decedent and other persons having claims or demands against decedent's estate, on whom a copy of this notice is required to be served, must file their claims with this court ON OR BEFORE THE LATER OF 3 MONTHS AFTER THE TIME OF THE FIRST PUBLICATION OF THIS NOTICE OR 30 DAYS AFTER THE DATE OF SERVICE OF A COPY OF THIS NOTICE ON THEM.

All other creditors of the decedent and other persons having claims or demands against decedent's estate must file their claims with this court WITHIN 3 MONTHS AFTER THE DATE OF THE FIRST PUBLICATION OF THIS NOTICE.

The personal representative has no duty to discover whether any property held at the time of the decedent's death by the decedent or the decedent's surviving spouse is property to which the Florida Uniform Disposition of Community Property Rights at Death Act as described in ss. 732.216-732.228, applies, or may apply, unless a written demand is made by a creditor as specified under s. 732.221, Florida Statutes.

ALL CLAIMS NOT FILED WITHIN THE TIME PERIODS SET FORTH IN FLORIDA STATUTES SECTION 733.702 WILL BE FOREVER BARRED.

NOTWITHSTANDING THE TIME PERIOD SET FORTH ABOVE, ANY CLAIM FILED TWO (2) YEARS OR MORE AFTER THE DECEDENT'S DATE OF DEATH IS BARRED.

The date of first publication of this notice is: June 12, 2026.

PATRICK FITZGIBBON
Personal Representative

1225 Gerona Terrace
 North Port, FL 34286
 Robert D. Hines, Esq.
 Attorney for Personal Representative
 Florida Bar No. 0413550
 Hines Norman Hines, P.L.
 1312 W. Fletcher Avenue, Suite B
 Tampa, FL 33612
 Telephone: 813-265-0100
 Email: rhines@hnh-law.com
 Secondary Email:
 ntservice@hnh-law.com
 June 12, 19, 2026 26-01356P

FIRST INSERTION

NOTICE OF ACTION - CONSTRUCTIVE SERVICE
 IN THE CIRCUIT COURT OF THE SIXTH JUDICIAL CIRCUIT IN AND FOR PASCO COUNTY, FLORIDA
 GENERAL JURISDICTION
 DIVISION
CASE NO. 2026CA001428CAAXWS
LAKEVIEW LOAN SERVICING, LLC,
Plaintiff, vs.
MONTY DRENTTEL, et al.
Defendant(s),

TO: MONTY DRENTTEL, UNKNOWN SPOUSE OF MONTY DRENTTEL, ELAINA O'CONNOR, whose residence is unknown and all parties having or claiming to have any right, title or interest in the property described in the mortgage being foreclosed herein.

YOU ARE HEREBY NOTIFIED that an action to foreclose a mortgage on the following property:

LOT 19, SIESTA TERRACE, ACCORDING TO THE MAP OR PLAT THEREOF, AS RECORDED IN PLAT BOOK 6, PAGE(S)11, OF PUBLIC RECORDS OF PASCO COUNTY, FLORIDA.

has been filed against you and you are required to serve a copy of your written defenses, if any, to it on counsel for Plaintiff, whose address is 6409 Congress Ave., Suite 100, Boca Raton, Florida 33487 on or before JULY 13TH, 2026/(30 days from Date of First Publication of this Notice) and file the original with the clerk of this court either before service on Plaintiff's attorney

or immediately thereafter; otherwise a default will be entered against you for the relief demanded in the complaint or petition filed herein.

If you are a person with a disability who needs any accommodation in order to participate in this proceeding, you are entitled, at no cost to you, to the provision of certain assistance. Please contact the Public Information Dept., Pasco County Government Center, 7530 Little Rd., New Port Richey, FL 34654; (727) 847-8110 (V) in New Port Richey; (352) 521-4274, ext 8110 (V) in Dade City, at least 7 days before your scheduled court appearance, or immediately upon receiving this notification if the time before the scheduled appearance is less than 7 days; if you are hearing impaired call 711. The court does not provide transportation and cannot accommodate for this service. Persons with disabilities needing transportation to court should contact their local public transportation providers for information regarding transportation services.

WITNESS my hand and the seal of this Court at Pasco County, Florida, this June 5, 2026

Nikki Alvarez-Sowles
 Pasco County Clerk & Comptroller
 (Seal) By: Haley Joyner
 Deputy Clerk

Robertson, Anschutz, Schneid, Crane & Partners, PLLC
 6409 Congress Ave., Suite 100
 Boca Raton, FL 33487
 PRIMARY EMAIL: flmail@rasg.com
 26-395759
 June 12, 19, 2026 26-01338P

FIRST INSERTION

NOTICE OF ACTION - CONSTRUCTIVE SERVICE
 IN THE CIRCUIT COURT OF THE SIXTH JUDICIAL CIRCUIT IN AND FOR PASCO COUNTY, FLORIDA
 GENERAL JURISDICTION
 DIVISION
CASE NO.

2026CA000428CAAXWS
TOWD POINT MORTGAGE TRUST 2020-4, U.S. BANK NATIONAL ASSOCIATION, AS INDENTURE TRUSTEE,
Plaintiff, vs.
MARY ANDERSEN, AS PERSONAL REPRESENTATIVE OF THE ESTATE OF CHRISTINE J. MESEROLE, DECEASED, et al.
Defendant(s),

TO: WENDY LEE WILES, whose residence is unknown and all parties having or claiming to have any right, title or interest in the property described in the mortgage being foreclosed herein.

YOU ARE HEREBY NOTIFIED that an action to foreclose a mortgage on the following property:

LOT 6, GULF COAST ESTATES, ACCORDING TO MAP OR PLAT THEREOF AS RECORDED IN PLAT BOOK 5, PAGE 100 OF THE PUBLIC RECORDS OF PASCO COUNTY, FLORIDA

has been filed against you and you are required to serve a copy of your written defenses, if any, to it on counsel for Plaintiff, whose address is 6409 Congress Ave., Suite 100, Boca Raton, Florida 33487 on or before JULY 13TH, 2026/(30 days from Date of First Publication of this Notice) and file the original with the clerk of this court either before service on Plaintiff's attorney or immediately thereafter; otherwise a default will be entered against you for the relief demanded in the complaint or petition filed herein.

If you are a person with a disability who needs any accommodation in order to participate in this proceeding, you are entitled, at no cost to you, to the provision of certain assistance. Please contact the Public Information Dept., Pasco County Government Center, 7530 Little Rd., New Port Richey, FL 34654; (727) 847-8110 (V) in New Port Richey; (352) 521-4274, ext 8110 (V) in Dade City, at least 7 days before your scheduled court appearance, or immediately upon receiving this notification if the time before the scheduled appearance is less than 7 days; if you are hearing impaired call 711. The court does not provide transportation and cannot accommodate for this service. Persons with disabilities needing transportation to court should contact their local public transportation providers for information regarding transportation services.

WITNESS my hand and the seal of this Court at Pasco County, Florida, this June 4, 2026

nal with the clerk of this court either before service on Plaintiff's attorney or immediately thereafter; otherwise a default will be entered against you for the relief demanded in the complaint or petition filed herein.

If you are a person with a disability who needs any accommodation in order to participate in this proceeding, you are entitled, at no cost to you, to the provision of certain assistance. Please contact the Public Information Dept., Pasco County Government Center, 7530 Little Rd., New Port Richey, FL 34654; (727) 847-8110 (V) in New Port Richey; (352) 521-4274, ext 8110 (V) in Dade City, at least 7 days before your scheduled court appearance, or immediately upon receiving this notification if the time before the scheduled appearance is less than 7 days; if you are hearing impaired call 711. The court does not provide transportation and cannot accommodate for this service. Persons with disabilities needing transportation to court should contact their local public transportation providers for information regarding transportation services.

WITNESS my hand and the seal of this Court at Pasco County, Florida, this June 4, 2026

Nikki Alvarez-Sowles
 Pasco County Clerk & Comptroller
 (Seal) By: Haley Joyner
 Deputy Clerk

ROBERTSON, ANSCHUTZ, AND SCHNEID, PL
 ATTORNEY FOR PLAINTIFF
 6409 Congress Ave., Suite 100
 Boca Raton, FL 33487
 PRIMARY EMAIL: flmail@rasg.com
 25-289389
 June 12, 19, 2026 26-01334P

FIRST INSERTION

NOTICE OF ACTION

IN THE CIRCUIT COURT OF THE SIXTH JUDICIAL CIRCUIT OF FLORIDA, IN AND FOR PASCO COUNTY
 CIVIL DIVISION
Case No. 2026CA000320CAAXWS
Division J3

GTE FEDERAL CREDIT UNION D/B/A GTE FINANCIAL
Plaintiff, vs.
UNKNOWN TRUSTEE OF THE GUZOWSKI, MARIANNE FAMILY TRUST U/A/D MAY 21, 2012, UNKNOWN BENEFICIARIES OF THE GUZOWSKI, MARIANNE FAMILY TRUST U/A/D MAY 21, 2012, DEBORAH L. PEARCE, AS KNOWN BENEFICIARY OF THE GUZOWSKI, MARIANNE FAMILY TRUST U/A/D MAY 21, 2012, MICHAEL GUZOWSKI, AS POSSIBLE BENEFICIARY OF THE GUZOWSKI, MARIANNE FAMILY TRUST U/A/D MAY 21, 2012, WILLIS J. PEARCE, AS POSSIBLE BENEFICIARY OF THE GUZOWSKI, MARIANNE FAMILY TRUST U/A/D MAY 21, 2012, et al.
Defendants.

TO: UNKNOWN TENANTS/OWNERS 1
 BELIEVED TO BE AVOIDING SERVICE OF PROCESS AT THE ADDRESS OF:
 9445 HOLNWN CT
 HUDSON, FL 34667

You are notified that an action to foreclose a mortgage on the following property in Pasco County, Florida:
 LOT 172 FAIRWAY OAKS UNIT FIVE, A SUBDIVISION ACCORDING TO THE PLAT THEREOF RECORDED IN PLAT BOOK 29, PAGES 137 THROUGH 140, INCLUSIVE, OF THE PUBLIC RECORDS OF PASCO COUNTY, FLORIDA.
 commonly known as 9445 HOLNWN

CT, HUDSON, FL 34667 has been filed against you and you are required to serve a copy of your written defenses, if any, to it on Joseph Paggi of Kass Shuler, P.A., plaintiff's attorney, whose address is P.O. Box 800, Tampa, Florida 33601, (813) 229-0900, on or before JULY 13, 2026, (or 30 days from the first date of publication, whichever is later) and file the original with the Clerk of this Court either before service on the Plaintiff's attorney or immediately thereafter; otherwise, a default will be entered against you for the relief demanded in the Complaint.

AMERICANS WITH DISABILITY ACT If you are a person with a disability who needs any accommodation in order to participate in this proceeding, you are entitled, at no cost to you, to the provision of certain assistance. Please contact either the Pasco County Customer Service Center, 8731 Citizens Drive, New Port Richey, FL 34654, (727) 847-2411 (V) or the Pasco County Risk Management Office, 7536 State Street, New Port Richey, FL 34654, (727) 847-8028 (V) at least 7 days before your scheduled court appearance, or immediately upon receiving this notification if the time before the scheduled appearance is less than 7 days; if you are hearing or voice impaired, call 711, e-mail: ada@pascoclerk.com

Dated: June 4, 2026

CLERK OF THE COURT
 (COURT SEAL)

Honorable Nikki Alvarez-Sowles, Esq., P.O. Box 338
 New Port Richey, Florida 34656-0338
 Nikki Alvarez-Sowles
 Pasco County Clerk & Comptroller
 Deputy Clerk: Shakira Ramirez Pagan
 Kass Shuler, P.A.,
 Plaintiff's Attorney
 P.O. Box 800
 Tampa, Florida 33601
 (813) 229-0900
 181350/2531900/MTS
 June 12, 19, 2026 26-01331P

FIRST INSERTION

NOTICE OF FORECLOSURE SALE
 IN THE CIRCUIT COURT OF THE SIXTH JUDICIAL CIRCUIT IN AND FOR PASCO COUNTY,
 CIVIL DIVISION
CASE NO.:
2025CA002236CAAXWS
FREEDOM MORTGAGE CORPORATION,
Plaintiff, vs.
DANIEL DEORAZIO; BARBARA TORRES A/K/A BARBARA DEORAZIO; UNITED STATES OF AMERICA ON BEHALF OF THE SECRETARY OF THE U.S. DEPARTMENT OF HOUSING AND URBAN DEVELOPMENT; KEY VISTA MASTER HOMEOWNERS ASSOCIATION, INC.; KEY VISTA VILLAS HOMEOWNERS ASSOCIATION, INC.; KEY VISTA SINGLE FAMILY HOMEOWNERS ASSOCIATION, INC.,
Defendants.

NOTICE OF SALE IS HEREBY GIVEN pursuant to the Order on Plaintiff's Motion to Cancel and Reset Foreclosure Sale entered on June 5, 2026 and the Final Judgment of Foreclosure entered on April 30, 2026 in Case No. 2025CA002236CAAXWS of the Circuit Court of the Sixth Judicial Circuit, in and for Pasco County, Florida, wherein FREEDOM MORTGAGE CORPORATION is Plaintiff and DANIEL DEORAZIO; BARBARA TORRES A/K/A BARBARA DEORAZIO; UNITED STATES OF AMERICA ON BEHALF OF THE SECRETARY OF THE U.S. DEPARTMENT OF HOUSING AND URBAN DEVELOPMENT; KEY VISTA MASTER HOMEOWNERS ASSOCIATION, INC.; KEY VISTA VILLAS HOMEOWNERS ASSOCIATION, INC.; and KEY VISTA SINGLE FAMILY HOMEOWNERS ASSOCIATION, INC., are Defendants, the Office of Nikki Alvarez-Sowles, Esq., Pasco County Clerk of the Court, will sell to the highest and best bidder for cash online at www.pasco.realforeclose.com, beginning at 11:00 a.m. on the 3rd day of August, 2026, in accordance with Section 45.031(10), Florida Statutes, the following described property as set forth in said Final Judgment, to wit:

LOT 488, KEY VISTA PHASE 3, PARCELS 12, 14 AND 16, ACCORDING TO THE MAP OR PLAT THEREOF AS RECORDED IN PLAT BOOK 43, PAGE 82, PUBLIC RECORDS OF PASCO COUNTY, FLORIDA

Also known as: 2434 Big Pine Drive, Holiday, FL 34691

Any person claiming an interest in the surplus funds from the sale, if any, other than the property owner as of the date of the lis pendens, must file a claim in accordance with Florida Statutes, Section 45.031.

If you are a person with a disability who needs any accommodation in order to participate in this proceeding, you are entitled, at no cost to you, to the provision of certain assistance. Please contact the Public Information Dept., Pasco County Government Center, 7530 Little Rd., New Port Richey, FL 34654; (727) 847-8110 (V) in New Port Richey; (352) 521-4274, ext 8110 (V) in Dade City, at least 7 days before your scheduled court appearance, or immediately upon receiving this notification if the time before the scheduled appearance is less than 7 days; if you are hearing impaired call 711. The court does not provide transportation and cannot accommodate for this service. Persons with disabilities needing transportation to court should contact their local public transportation providers for information regarding transportation services.

Dated this 8th day of June, 2026.
 Sokolof Remtulla, LLP
 By: /s/ Matthew Shapanks
 Matthew Shapanka, Esq.
 Bar No: 52874
 SOKOLOF REMTULLA, LLP
 1800 NW Corporate Blvd., Ste. 302,
 Boca Raton, FL 33431,
 E-mail: pleadings@sokrem.com,
 Counsel for Plaintiff
 File No.: 25-01576
 June 12, 19, 2026 26-01345P

FIRST INSERTION

NOTICE OF FORECLOSURE SALE
 IN THE CIRCUIT COURT OF THE 6TH JUDICIAL CIRCUIT, IN AND FOR PASCO COUNTY, FLORIDA
 CIVIL DIVISION
CASE NO. 2025CA001347CAAXWS
CROSSCOUNTRY MORTGAGE, LLC,
Plaintiff, vs.
QUINTIN PETERS; UNKNOWN SPOUSE OF QUINTIN PETERS; ALEXIS DANIELLE YARBROUGH; UNKNOWN SPOUSE OF ALEXIS DANIELLE YARBROUGH; UNKNOWN PERSON(S) IN POSSESSION OF THE SUBJECT PROPERTY,
Defendant(s)

NOTICE IS HEREBY GIVEN pursuant to a Final Judgment of Foreclosure filed May 22, 2026 and entered in Case No. 2025CA001347CAAXWS, of the Circuit Court of the 6th Judicial Circuit in and for PASCO County, Florida, wherein CROSSCOUNTRY MORTGAGE, LLC is Plaintiff and QUINTIN PETERS; UNKNOWN SPOUSE OF QUINTIN PETERS; ALEXIS DANIELLE YARBROUGH; UNKNOWN SPOUSE OF ALEXIS DANIELLE YARBROUGH; UNKNOWN PERSON(S) IN POSSESSION OF THE SUBJECT PROPERTY; are defendants. NIKKI ALVAREZ-SOWLES, ESQ., the Clerk of the Circuit Court, will sell to the highest and best bidder for cash by ELECTRONIC SALE AT: WWW.PASCO.REALFORECLOSE.COM, at 11:00 A.M., on July 6, 2026, the following described property as set forth in said Final Judgment, to wit:

LOT 2305, REGENCY PARK,

UNIT TWELVE, ACCORDING TO THE PLAT THEREOF AS RECORDED IN PLAT BOOK 16, PAGES 7 THROUGH 9, OF THE PUBLIC RECORDS OF PASCO COUNTY, FLORIDA.

Any person claiming an interest in the surplus from the sale, if any, other than the property owner as of the date of the lis pendens must file a claim before the Clerk reports the surplus as unclaimed.

This notice is provided pursuant to Administrative Order 2010-045 PA/PICIR "If you are a person with disability who needs any accommodation in order to participate in this proceeding, you are entitled, at no cost to you, to the provision of certain assistance. Please contact Public Information Dept., Pasco County Government Center, 7530 Little Rd., New Port Richey, FL 34654; (727) 847-8110 (V) for proceedings in New Port Richey; (352) 521-4274, ext. 8110 (V) for proceedings in Dade City at least 7 days before your scheduled court appearance, or immediately upon receiving this notification if the time before the scheduled appearance is less than 7 days; if you are hearing or voice impaired, call 711."

Dated this 4th day of June 2026.
 By: /s/ Marc Granger, Esq.
 Bar No.: 1468701
 Kahane & Associates, P.A.
 1619 NW 136th Avenue,
 Suite D-220
 Sunrise, Florida 33323
 Telephone: (954) 382-3486
 Telefacsimile: (954) 382-5380
 Designated service email:
 notice@kahaneandassociates.com
 File No.: 24-01139 NML
 June 12, 19, 2026 26-01320P

--- ACTIONS / SALES ---

FIRST INSERTION

NOTICE OF FORECLOSURE SALE IN THE CIRCUIT COURT OF THE SIXTH JUDICIAL CIRCUIT OF FLORIDA IN AND FOR PASCO COUNTY GENERAL JURISDICTION DIVISION

CASE NO. 2025CA001399CAAXES FREEDOM MORTGAGE CORPORATION, Plaintiff, vs. WILLIE ANSLEY A/K/A WILLIE E. ANSLEY, et al., Defendant.

NOTICE IS HEREBY GIVEN pursuant to a Summary Final Judgment of Foreclosure entered September 22, 2025 in Civil Case No. 2025CA001399CAAXES of the Circuit Court of the SIXTH JUDICIAL CIRCUIT in and for Pasco County,

Dade City, Florida, wherein FREEDOM MORTGAGE CORPORATION is Plaintiff and Willie Ansley a/k/a Willie E. Ansley, et al., are Defendants, the Clerk of Court, NIKKI ALVAREZ-SOWLES, ESQ., will sell to the highest and best bidder for cash electronically at www.pasco.realforeclose.com in accordance with Chapter 45, Florida Statutes on the 8th day of July, 2026 at 11:00 AM on the following described property as set forth in said Summary Final Judgment, to-wit: The West 1/2 of Lots 1 and 2; and the North 10 feet of the West 1/2 of Lot 3, in Block 46, of the City of Zephyrhills (formerly town of Zephyrhills), as per plat thereof, recorded in Plat Book 1, Page 54, Public Records of Pasco County, Florida. Parcel Number:

11-26-21-0010-04600-0015 Any person claiming an interest in the surplus from the sale, if any, other than the property owner as of the date of the lis pendens, must file a claim before the clerk reports the surplus as unclaimed. If you are a person with a disability who needs any accommodation in order to participate in this proceeding, you are entitled, at no cost to you to the provision of certain assistance. Within two (2) working days of your receipt of this (describe notice/order) please contact the Public Information Dept., Pasco County Government Center, 7530 Little Rd., New Port Richey, FL 34654; (727) 847-8110 (V) in New Port Richey; (352) 521-4274, ext. 8110 (V) in Dade City; via 1-800-955-8771 if you are hearing impaired. The court does not provide transportation and cannot

accommodate for this service. Persons with disabilities needing transportation to court should contact their local public transportation providers for information regarding disabled transportation services. /s/Robyn Katz Robyn Katz, Esq. McCalla Raymer Leibert Pierce, LLP Attorney for Plaintiff 225 East Robinson Street, Suite 155 Orlando, FL 32801 Phone: (407) 674-1850 Fax: (321) 248-0420 Email: MRService@mccalla.com Fla. Bar No.: 146803 23-07374FL June 12, 19, 2026 26-01366P

FIRST INSERTION

NOTICE OF ACTION FORECLOSURE PROCEEDINGS-PROPERTY

IN THE CIRCUIT COURT OF THE SIXTH JUDICIAL CIRCUIT IN AND FOR PASCO COUNTY, FLORIDA CIVIL DIVISION

Case #: 2026CA001661CAAXWS DIVISION: J2

JPMorgan Chase Bank, National Association Plaintiff, -vs-

Unknown Heirs, Devisees, Grantees, Assignees, Creditors, Lienors, and Trustees of Deborah Givens a/k/a Deborah Ann Givens a/k/a Deborah A. Givens f/k/a Deborah Ann Clark f/k/a Deborah Ann Cannon, Deceased, and All Other Persons Claiming by and Through, Under, Against The Named Defendant (s);

Michael Robert Clark a/k/a Michael R. Clark a/k/a Michael Clark; Erin Marie Grimes a/k/a Erin Grimes a/k/a Erin Marie Clark; Kevin Ryan Clark; Unknown Spouse of Michael Robert Clark a/k/a Michael R. Clark a/k/a Michael Clark; Unknown Spouse of Erin Marie Grimes a/k/a Erin Grimes a/k/a Erin Marie Clark; Unknown Spouse of Kevin Ryan Clark; Service Finance Company, LLC; Good Leap, LLC; Clerk of Circuit Court of Pasco County, Florida; Unknown Person in Possession of the Subject Property Defendant(s).

TO: Unknown Heirs, Devisees, Grantees, Assignees, Creditors, Lienors, and Trustees of Deborah Givens a/k/a Deborah Ann Givens a/k/a Deborah A. Givens f/k/a Deborah Ann Clark f/k/a Deborah Ann Cannon, Deceased, and All Other Persons Claiming by and Through, Under, Against The Named Defendant (s):

Residence unknown, if living, including any unknown spouse of the said Defendants, if either has remarried and if either or both of said Defendants are dead, their respective unknown heirs, devisees, grantees, assignees, creditors, lienors, and trustees, and all other persons claiming by, through, under or against the named Defendant(s); and the aforementioned named Defendant(s) and such of the aforementioned unknown Defendants and such of the aforementioned unknown Defendants as may be infants, incompetents

or otherwise not sui juris. YOU ARE HEREBY NOTIFIED that an action has been commenced to foreclose a mortgage on the following real property, lying and being and situated in Pasco County, Florida, more particularly described as follows: LOT 6, 7 AND 8, BLOCK G, MOON LAKE ESTATES UNIT ONE, AS RECORDED IN PLAT BOOK 4, PAGES 72 AND 73, PUBLIC RECORDS OF PASCO COUNTY, FLORIDA. more commonly known as 12850 Pensacola Avenue, New Port Richey, FL 34654. This action has been filed against you and you are required to serve a copy of your written defense, if any, upon LOGS LEGAL GROUP LLP, Attorneys for Plaintiff, whose address is 750 Park of Commerce Blvd., Suite 130, Boca Raton, FL 33487, on or before JULY 13, 2026 and file the original with the clerk of this Court either before with service on Plaintiff's attorney or immediately thereafter; otherwise a default will be entered against you for the relief demanded in the Complaint. If you are a person with a disability who needs any accommodation in order to participate in this proceeding, you are entitled, at no cost to you, to the provision of certain assistance. Please contact either the Pasco County Customer Service Center, 8731 Citizens Drive, New Port Richey, FL 34654, (727) 847-2411 (V) or the Pasco County Risk Management Office, 7536 State Street, New Port Richey, FL 34654, (727) 847-8028 (V) at least 7 days before your scheduled court appearance, or immediately upon receiving this notification if the time before the scheduled appearance is less than 7 days; if you are hearing or voice impaired, call 711. WITNESS my hand and seal of this Court on the June 4, 2026. Nikki Alvarez-Sowles, Esq. Circuit and County Courts (SEAL) By: Shakira Ramirez Pagan Deputy Clerk LOGS LEGAL GROUP LLP, Attorneys for Plaintiff, 750 Park of Commerce Blvd., Suite 130, Boca Raton, FL 33487 26-335360 FCO1 CHE June 12, 19, 2026 26-01332P

or otherwise not sui juris. YOU ARE HEREBY NOTIFIED that an action has been commenced to foreclose a mortgage on the following real property, lying and being and situated in Pasco County, Florida, more particularly described as follows: LOT 6, 7 AND 8, BLOCK G, MOON LAKE ESTATES UNIT ONE, AS RECORDED IN PLAT BOOK 4, PAGES 72 AND 73, PUBLIC RECORDS OF PASCO COUNTY, FLORIDA. more commonly known as 12850 Pensacola Avenue, New Port Richey, FL 34654. This action has been filed against you and you are required to serve a copy of your written defense, if any, upon LOGS LEGAL GROUP LLP, Attorneys for Plaintiff, whose address is 750 Park of Commerce Blvd., Suite 130, Boca Raton, FL 33487, on or before JULY 13, 2026 and file the original with the clerk of this Court either before with service on Plaintiff's attorney or immediately thereafter; otherwise a default will be entered against you for the relief demanded in the Complaint. If you are a person with a disability who needs any accommodation in order to participate in this proceeding, you are entitled, at no cost to you, to the provision of certain assistance. Please contact either the Pasco County Customer Service Center, 8731 Citizens Drive, New Port Richey, FL 34654, (727) 847-2411 (V) or the Pasco County Risk Management Office, 7536 State Street, New Port Richey, FL 34654, (727) 847-8028 (V) at least 7 days before your scheduled court appearance, or immediately upon receiving this notification if the time before the scheduled appearance is less than 7 days; if you are hearing or voice impaired, call 711. WITNESS my hand and seal of this Court on the June 4, 2026. Nikki Alvarez-Sowles, Esq. Circuit and County Courts (SEAL) By: Shakira Ramirez Pagan Deputy Clerk LOGS LEGAL GROUP LLP, Attorneys for Plaintiff, 750 Park of Commerce Blvd., Suite 130, Boca Raton, FL 33487 26-335360 FCO1 CHE June 12, 19, 2026 26-01332P

Case #: 2026CC003385CCAXWS Trust Bank Plaintiff, -vs- Unknown Heirs, Devisees, Grantees, Assignees, Creditors, Lienors, and Trustees of James E. LaRose a/k/a James E. La Rose a/k/a James Edward LaRose a/k/a James Edward La Rose a/k/a James La Rose, Deceased, and All Other Persons Claiming by and Through, Under, Against The Named Defendant(s); Deborah June LaRose a/k/a Deborah J. LaRose; Joanna Marie LaRose a/k/a Joanna LaRose; Unknown Spouse of Deborah June LaRose a/k/a Deborah J. LaRose; Unknown Spouse of Joanna Marie LaRose a/k/a Joanna LaRose; Foundation Finance Company, LLC; Unknown Parties in Possession #1, if living, and all Unknown Parties claiming by, through, under and against the above named Defendant(s);

Unknown Heirs, Devisees, Grantees, Assignees, Creditors, Lienors, and Trustees of James E. LaRose a/k/a James E. La Rose a/k/a James Edward LaRose a/k/a James La Rose, Deceased, and All Other Persons Claiming by and Through, Under, Against The Named Defendant(s): 4428 Terry Loop, New Port Richey, FL 34652

Residence unknown, if living, including any unknown spouse of the said Defendants, if either has remarried and if either or both of said Defendants are dead, their respective unknown heirs, devisees, grantees, assignees, creditors, lienors, and trustees, and all other persons claiming by, through, under or against the named Defendant(s); and the aforementioned named Defendant(s) and such of the aforementioned unknown Defendants and such of the aforementioned unknown Defendants as may be infants, incompetents

or otherwise not sui juris. YOU ARE HEREBY NOTIFIED that an action has been commenced to foreclose a mortgage on the following real property, lying and being and situated in Pasco County, Florida, more particularly described as follows: LOT 33, BARBY HEIGHTS FIRST ADDITION, ACCORDING TO THE MAP OR PLAT THEREOF AS RECORDED IN PLAT BOOK 9, PAGE 28, OF THE PUBLIC RECORDS OF PASCO COUNTY, FLORIDA more commonly known as 4428 Terry Loop, New Port Richey, FL 34652. This action has been filed against you and you are required to serve a copy of your written defense, if any, upon LOGS LEGAL GROUP LLP, Attorneys for Plaintiff, whose address is 750 Park of Commerce Blvd., Suite 130, Boca Raton, FL 33487, on or before JULY 13, 2026 and file the original with the clerk of this Court either before with service on Plaintiff's attorney or immediately thereafter; otherwise a default will be entered against you for the relief demanded in the Complaint. If you are a person with a disability who needs any accommodation in order to participate in this proceeding, you are entitled, at no cost to you, to the provision of certain assistance. Please contact either the Pasco County Customer Service Center, 8731 Citizens Drive, New Port Richey, FL 34654, (727) 847-2411 (V) or the Pasco County Risk Management Office, 7536 State Street, New Port Richey, FL 34654, (727) 847-8028 (V) at least 7 days before your scheduled court appearance, or immediately upon receiving this notification if the time before the scheduled appearance is less than 7 days; if you are hearing or voice impaired, call 711. WITNESS my hand and seal of this Court on the June 3, 2026. Nikki Alvarez-Sowles, Esq. Circuit and County Courts (SEAL) By: Shakira Ramirez Pagan Deputy Clerk LOGS LEGAL GROUP LLP, Attorneys for Plaintiff, 750 Park of Commerce Blvd., Suite 130, Boca Raton, FL 33487 26-335574 FCO1 SUT June 12, 19, 2026 26-01333P

or otherwise not sui juris. YOU ARE HEREBY NOTIFIED that an action has been commenced to foreclose a mortgage on the following real property, lying and being and situated in Pasco County, Florida, more particularly described as follows: LOT 33, BARBY HEIGHTS FIRST ADDITION, ACCORDING TO THE MAP OR PLAT THEREOF AS RECORDED IN PLAT BOOK 9, PAGE 28, OF THE PUBLIC RECORDS OF PASCO COUNTY, FLORIDA more commonly known as 4428 Terry Loop, New Port Richey, FL 34652. This action has been filed against you and you are required to serve a copy of your written defense, if any, upon LOGS LEGAL GROUP LLP, Attorneys for Plaintiff, whose address is 750 Park of Commerce Blvd., Suite 130, Boca Raton, FL 33487, on or before JULY 13, 2026 and file the original with the clerk of this Court either before with service on Plaintiff's attorney or immediately thereafter; otherwise a default will be entered against you for the relief demanded in the Complaint. If you are a person with a disability who needs any accommodation in order to participate in this proceeding, you are entitled, at no cost to you, to the provision of certain assistance. Please contact either the Pasco County Customer Service Center, 8731 Citizens Drive, New Port Richey, FL 34654, (727) 847-2411 (V) or the Pasco County Risk Management Office, 7536 State Street, New Port Richey, FL 34654, (727) 847-8028 (V) at least 7 days before your scheduled court appearance, or immediately upon receiving this notification if the time before the scheduled appearance is less than 7 days; if you are hearing or voice impaired, call 711. WITNESS my hand and seal of this Court on the June 3, 2026. Nikki Alvarez-Sowles, Esq. Circuit and County Courts (SEAL) By: Shakira Ramirez Pagan Deputy Clerk LOGS LEGAL GROUP LLP, Attorneys for Plaintiff, 750 Park of Commerce Blvd., Suite 130, Boca Raton, FL 33487 26-335574 FCO1 SUT June 12, 19, 2026 26-01333P

or otherwise not sui juris. YOU ARE HEREBY NOTIFIED that an action has been commenced to foreclose a mortgage on the following real property, lying and being and situated in Pasco County, Florida, more particularly described as follows: LOT 33, BARBY HEIGHTS FIRST ADDITION, ACCORDING TO THE MAP OR PLAT THEREOF AS RECORDED IN PLAT BOOK 9, PAGE 28, OF THE PUBLIC RECORDS OF PASCO COUNTY, FLORIDA more commonly known as 4428 Terry Loop, New Port Richey, FL 34652. This action has been filed against you and you are required to serve a copy of your written defense, if any, upon LOGS LEGAL GROUP LLP, Attorneys for Plaintiff, whose address is 750 Park of Commerce Blvd., Suite 130, Boca Raton, FL 33487, on or before JULY 13, 2026 and file the original with the clerk of this Court either before with service on Plaintiff's attorney or immediately thereafter; otherwise a default will be entered against you for the relief demanded in the Complaint. If you are a person with a disability who needs any accommodation in order to participate in this proceeding, you are entitled, at no cost to you, to the provision of certain assistance. Please contact either the Pasco County Customer Service Center, 8731 Citizens Drive, New Port Richey, FL 34654, (727) 847-2411 (V) or the Pasco County Risk Management Office, 7536 State Street, New Port Richey, FL 34654, (727) 847-8028 (V) at least 7 days before your scheduled court appearance, or immediately upon receiving this notification if the time before the scheduled appearance is less than 7 days; if you are hearing or voice impaired, call 711. WITNESS my hand and seal of this Court on the June 3, 2026. Nikki Alvarez-Sowles, Esq. Circuit and County Courts (SEAL) By: Shakira Ramirez Pagan Deputy Clerk LOGS LEGAL GROUP LLP, Attorneys for Plaintiff, 750 Park of Commerce Blvd., Suite 130, Boca Raton, FL 33487 26-335574 FCO1 SUT June 12, 19, 2026 26-01333P

or otherwise not sui juris. YOU ARE HEREBY NOTIFIED that an action has been commenced to foreclose a mortgage on the following real property, lying and being and situated in Pasco County, Florida, more particularly described as follows: LOT 33, BARBY HEIGHTS FIRST ADDITION, ACCORDING TO THE MAP OR PLAT THEREOF AS RECORDED IN PLAT BOOK 9, PAGE 28, OF THE PUBLIC RECORDS OF PASCO COUNTY, FLORIDA more commonly known as 4428 Terry Loop, New Port Richey, FL 34652. This action has been filed against you and you are required to serve a copy of your written defense, if any, upon LOGS LEGAL GROUP LLP, Attorneys for Plaintiff, whose address is 750 Park of Commerce Blvd., Suite 130, Boca Raton, FL 33487, on or before JULY 13, 2026 and file the original with the clerk of this Court either before with service on Plaintiff's attorney or immediately thereafter; otherwise a default will be entered against you for the relief demanded in the Complaint. If you are a person with a disability who needs any accommodation in order to participate in this proceeding, you are entitled, at no cost to you, to the provision of certain assistance. Please contact either the Pasco County Customer Service Center, 8731 Citizens Drive, New Port Richey, FL 34654, (727) 847-2411 (V) or the Pasco County Risk Management Office, 7536 State Street, New Port Richey, FL 34654, (727) 847-8028 (V) at least 7 days before your scheduled court appearance, or immediately upon receiving this notification if the time before the scheduled appearance is less than 7 days; if you are hearing or voice impaired, call 711. WITNESS my hand and seal of this Court on the June 3, 2026. Nikki Alvarez-Sowles, Esq. Circuit and County Courts (SEAL) By: Shakira Ramirez Pagan Deputy Clerk LOGS LEGAL GROUP LLP, Attorneys for Plaintiff, 750 Park of Commerce Blvd., Suite 130, Boca Raton, FL 33487 26-335574 FCO1 SUT June 12, 19, 2026 26-01333P

or otherwise not sui juris. YOU ARE HEREBY NOTIFIED that an action has been commenced to foreclose a mortgage on the following real property, lying and being and situated in Pasco County, Florida, more particularly described as follows: LOT 33, BARBY HEIGHTS FIRST ADDITION, ACCORDING TO THE MAP OR PLAT THEREOF AS RECORDED IN PLAT BOOK 9, PAGE 28, OF THE PUBLIC RECORDS OF PASCO COUNTY, FLORIDA more commonly known as 4428 Terry Loop, New Port Richey, FL 34652. This action has been filed against you and you are required to serve a copy of your written defense, if any, upon LOGS LEGAL GROUP LLP, Attorneys for Plaintiff, whose address is 750 Park of Commerce Blvd., Suite 130, Boca Raton, FL 33487, on or before JULY 13, 2026 and file the original with the clerk of this Court either before with service on Plaintiff's attorney or immediately thereafter; otherwise a default will be entered against you for the relief demanded in the Complaint. If you are a person with a disability who needs any accommodation in order to participate in this proceeding, you are entitled, at no cost to you, to the provision of certain assistance. Please contact either the Pasco County Customer Service Center, 8731 Citizens Drive, New Port Richey, FL 34654, (727) 847-2411 (V) or the Pasco County Risk Management Office, 7536 State Street, New Port Richey, FL 34654, (727) 847-8028 (V) at least 7 days before your scheduled court appearance, or immediately upon receiving this notification if the time before the scheduled appearance is less than 7 days; if you are hearing or voice impaired, call 711. WITNESS my hand and seal of this Court on the June 3, 2026. Nikki Alvarez-Sowles, Esq. Circuit and County Courts (SEAL) By: Shakira Ramirez Pagan Deputy Clerk LOGS LEGAL GROUP LLP, Attorneys for Plaintiff, 750 Park of Commerce Blvd., Suite 130, Boca Raton, FL 33487 26-335574 FCO1 SUT June 12, 19, 2026 26-01333P

FIRST INSERTION

NOTICE OF ACTION Constructive Service of Process IN THE CIRCUIT COURT OF THE SIXTH JUDICIAL CIRCUIT IN AND FOR PASCO COUNTY, FLORIDA

Case No. 2026CA000976CAAXWS Honorable Judge: BYRD, KIMBERLY SHARPE PLANET HOME LENDING, LLC Plaintiff, vs. ANTHONY E. BUFFUM; et al. Defendants,

TO: ANTHONY E. BUFFUM and UNKNOWN SPOUSE OF ANTHONY E. BUFFUM. Last Known Address: 9961 EAGLES POINT CIRCLE, UNIT 4, PORT RICHEY FL 34668.

YOU ARE NOTIFIED that an action to Foreclose a Mortgage on the following property, commonly known as 9961 EAGLES POINT CIRCLE, UNIT 4, PORT RICHEY FL 34668, and more particularly described as follows: UNIT NO. D, BUILDING 17, OF EAGLES POINT, A CONDOMINIUM, UNIT TWO, ACCORDING TO THE DECLARATION OF CONDOMINIUM THEREOF, AS RECORDED IN OFFICIAL RECORDS BOOK 1079, PAGE 840, AND SUBSEQUENT AMENDMENTS THERETO, OF THE PUBLIC RECORDS OF PASCO COUNTY, FLORIDA, TOGETHER WITH ALL AMENDMENTS THERETO AND AN UNDIVIDED INTEREST IN THE COMMON ELEMENTS OF SAID CONDOMINIUM. APN No. 21-25-16-011A-01700-00D0 COMMONLY KNOWN AS: 9961

Eagles Point Circle, Unit 4, Port Richey, FL 34668, has been filed against you and you are required to serve of a copy of your written defenses, if any, to it on Matthew T. Wasinger, Esquire, the Plaintiff's attorney, whose address is 605 E. Robinson Street, Suite 730, Orlando, FL 32801 within 30 days from the first proof of publication of this Notice, and file the original with the clerk of this court either before service on the plaintiffs attorney or immediately thereafter; otherwise a default will be entered against you for the relief demanded in the complaint or petition. DUE ON OR BEFORE JULY 13, 2026

If you are a person with a disability who needs any accommodation in order to participate in this proceeding, you are entitled, at no cost to you, to the provision of certain assistance. Please contact the Public Information Dept., Pasco County Government Center, 7530 Little Rd., New Port Richey, FL 34654; (727) 847-8110 (V) in New Port Richey; (352) 521-4274, ext 8110 (V) in Dade City, at least 7 days before your scheduled court appearance, or immediately upon receiving this notification if the time before the scheduled appearance is less than 7 days; if you are hearing impaired call 711. The court does not provide transportation and cannot accommodate for this service. Persons with disabilities needing transportation to court should contact their local public transportation providers for information regarding transportation services. DATED ON June 4, 2026. Nikki Alvarez-Sowles PASCO County Clerk & Comptroller Deputy Clerk: Shakira Ramirez Pagan June 12, 19, 2026 26-01332P

or otherwise not sui juris. YOU ARE HEREBY NOTIFIED that an action has been commenced to foreclose a mortgage on the following real property, lying and being and situated in Pasco County, Florida, more particularly described as follows: LOT 11, in Block 10, of Copper-spring Phase 2, according to plat thereof as recorded in Plat Book 81, Page 84, of the Public Records of Pasco County, Florida. has been filed against you and you are required to serve a copy of your written defenses, if any, to it, on MILLER,

or otherwise not sui juris. YOU ARE HEREBY NOTIFIED that an action has been commenced to foreclose a mortgage on the following real property, lying and being and situated in Pasco County, Florida, more particularly described as follows: LOT 11, in Block 10, of Copper-spring Phase 2, according to plat thereof as recorded in Plat Book 81, Page 84, of the Public Records of Pasco County, Florida. has been filed against you and you are required to serve a copy of your written defenses, if any, to it, on MILLER,

or otherwise not sui juris. YOU ARE HEREBY NOTIFIED that an action has been commenced to foreclose a mortgage on the following real property, lying and being and situated in Pasco County, Florida, more particularly described as follows: LOT 11, in Block 10, of Copper-spring Phase 2, according to plat thereof as recorded in Plat Book 81, Page 84, of the Public Records of Pasco County, Florida. has been filed against you and you are required to serve a copy of your written defenses, if any, to it, on MILLER,

or otherwise not sui juris. YOU ARE HEREBY NOTIFIED that an action has been commenced to foreclose a mortgage on the following real property, lying and being and situated in Pasco County, Florida, more particularly described as follows: LOT 11, in Block 10, of Copper-spring Phase 2, according to plat thereof as recorded in Plat Book 81, Page 84, of the Public Records of Pasco County, Florida. has been filed against you and you are required to serve a copy of your written defenses, if any, to it, on MILLER,

FIRST INSERTION

NOTICE OF ACTION FORECLOSURE PROCEEDINGS-PROPERTY

IN THE COUNTY COURT OF THE SIXTH JUDICIAL CIRCUIT IN AND FOR PASCO COUNTY, FLORIDA CIVIL DIVISION

Case #: 2026CC003385CCAXWS Trust Bank Plaintiff, -vs- Unknown Heirs, Devisees, Grantees, Assignees, Creditors, Lienors, and Trustees of James E. LaRose a/k/a James E. La Rose a/k/a James Edward LaRose a/k/a James Edward La Rose a/k/a James La Rose, Deceased, and All Other Persons Claiming by and Through, Under, Against The Named Defendant(s); Deborah June LaRose a/k/a Deborah J. LaRose; Joanna Marie LaRose a/k/a Joanna LaRose; Unknown Spouse of Deborah June LaRose a/k/a Deborah J. LaRose; Unknown Spouse of Joanna Marie LaRose a/k/a Joanna LaRose; Foundation Finance Company, LLC; Unknown Parties in Possession #1, if living, and all Unknown Parties claiming by, through, under and against the above named Defendant(s);

Unknown Heirs, Devisees, Grantees, Assignees, Creditors, Lienors, and Trustees of James E. LaRose a/k/a James E. La Rose a/k/a James Edward LaRose a/k/a James La Rose, Deceased, and All Other Persons Claiming by and Through, Under, Against The Named Defendant(s): 4428 Terry Loop, New Port Richey, FL 34652

Residence unknown, if living, including any unknown spouse of the said Defendants, if either has remarried and if either or both of said Defendants are dead, their respective unknown heirs, devisees, grantees, assignees, creditors, lienors, and trustees, and all other persons claiming by, through, under or against the named Defendant(s); and the aforementioned named Defendant(s) and such of the aforementioned unknown Defendants and such of the aforementioned unknown Defendants as may be infants, incompetents

or otherwise not sui juris. YOU ARE HEREBY NOTIFIED that an action has been commenced to foreclose a mortgage on the following real property, lying and being and situated in Pasco County, Florida, more particularly described as follows: LOT 33, BARBY HEIGHTS FIRST ADDITION, ACCORDING TO THE MAP OR PLAT THEREOF AS RECORDED IN PLAT BOOK 9, PAGE 28, OF THE PUBLIC RECORDS OF PASCO COUNTY, FLORIDA more commonly known as 4428 Terry Loop, New Port Richey, FL 34652. This action has been filed against you and you are required to serve a copy of your written defense, if any, upon LOGS LEGAL GROUP LLP, Attorneys for Plaintiff, whose address is 750 Park of Commerce Blvd., Suite 130, Boca Raton, FL 33487, on or before JULY 13, 2026 and file the original with the clerk of this Court either before with service on Plaintiff's attorney or immediately thereafter; otherwise a default will be entered against you for the relief demanded in the Complaint. If you are a person with a disability who needs any accommodation in order to participate in this proceeding, you are entitled, at no cost to you, to the provision of certain assistance. Please contact either the Pasco County Customer Service Center, 8731 Citizens Drive, New Port Richey, FL 34654, (727) 847-2411 (V) or the Pasco County Risk Management Office, 7536 State Street, New Port Richey, FL 34654, (727) 847-8028 (V) at least 7 days before your scheduled court appearance, or immediately upon receiving this notification if the time before the scheduled appearance is less than 7 days; if you are hearing or voice impaired, call 711. WITNESS my hand and seal of this Court on the June 3, 2026. Nikki Alvarez-Sowles, Esq. Circuit and County Courts (SEAL) By: Shakira Ramirez Pagan Deputy Clerk LOGS LEGAL GROUP LLP, Attorneys for Plaintiff, 750 Park of Commerce Blvd., Suite 130, Boca Raton, FL 33487 26-335574 FCO1 SUT June 12, 19, 2026 26-01333P

or otherwise not sui juris. YOU ARE HEREBY NOTIFIED that an action has been commenced to foreclose a mortgage on the following real property, lying and being and situated in Pasco County, Florida, more particularly described as follows: LOT 33, BARBY HEIGHTS FIRST ADDITION, ACCORDING TO THE MAP OR PLAT THEREOF AS RECORDED IN PLAT BOOK 9, PAGE 28, OF THE PUBLIC RECORDS OF PASCO COUNTY, FLORIDA more commonly known as 4428 Terry Loop, New Port Richey, FL 34652. This action has been filed against you and you are required to serve a copy of your written defense, if any, upon LOGS LEGAL GROUP LLP, Attorneys for Plaintiff, whose address is 750 Park of Commerce Blvd., Suite 130, Boca Raton, FL 33487, on or before JULY 13, 2026 and file the original with the clerk of this Court either before with service on Plaintiff's attorney or immediately thereafter; otherwise a default will be entered against you for the relief demanded in the Complaint. If you are a person with a disability who needs any accommodation in order to participate in this proceeding, you are entitled, at no cost to you, to the provision of certain assistance. Please contact either the Pasco County Customer Service Center, 8731 Citizens Drive, New Port Richey, FL 34654, (727) 847-2411 (V) or the Pasco County Risk Management Office, 7536 State Street, New Port Richey, FL 34654, (727) 847-8028 (V) at least 7 days before your scheduled court appearance, or immediately upon receiving this notification if the time before the scheduled appearance is less than 7 days; if you are hearing or voice impaired, call 711. WITNESS my hand and seal of this Court on the June 3, 2026. Nikki Alvarez-Sowles, Esq. Circuit and County Courts (SEAL) By: Shakira Ramirez Pagan Deputy Clerk LOGS LEGAL GROUP LLP, Attorneys for Plaintiff, 750 Park of Commerce Blvd., Suite 130, Boca Raton, FL 33487 26-335574 FCO1 SUT June 12, 19, 2026 26-01333P

or otherwise not sui juris. YOU ARE HEREBY NOTIFIED that an action has been commenced to foreclose a mortgage on the following real property, lying and being and situated in Pasco County, Florida, more particularly described as follows: LOT 33, BARBY HEIGHTS FIRST ADDITION, ACCORDING TO THE MAP OR PLAT THEREOF AS RECORDED IN PLAT BOOK 9, PAGE 28, OF THE PUBLIC RECORDS OF PASCO COUNTY, FLORIDA more commonly known as 4428 Terry Loop, New Port Richey, FL 34652. This action has been filed against you and you are required to serve a copy of your written defense, if any, upon LOGS LEGAL GROUP LLP, Attorneys for Plaintiff, whose address is 750 Park of Commerce Blvd., Suite 130, Boca Raton, FL 33487, on or before JULY 13, 2026 and file the original with the clerk of this Court either before with service on Plaintiff's attorney or immediately thereafter; otherwise a default will be entered against you for the relief demanded in the Complaint. If you are a person with a disability who needs any accommodation in order to participate in this proceeding, you are entitled, at no cost to you, to the provision of certain assistance. Please contact either the Pasco County Customer Service Center, 8731 Citizens Drive, New Port Richey, FL 34654, (727) 847-2411 (V) or the Pasco County Risk Management Office, 7536 State Street, New Port Richey, FL 34654, (727) 847-8028 (V) at least 7 days before your scheduled court appearance, or immediately upon receiving this notification if the time before the scheduled appearance is less than 7 days; if you are hearing or voice impaired, call 711. WITNESS my hand and seal of this Court on the June 3, 2026. Nikki Alvarez-Sowles, Esq. Circuit and County Courts (SEAL) By: Shakira Ramirez Pagan Deputy Clerk LOGS LEGAL GROUP LLP, Attorneys for Plaintiff, 750 Park of Commerce Blvd., Suite 130, Boca Raton, FL 33487 26-335574 FCO1 SUT June 12, 19, 2026 26-01333P

or otherwise not sui juris. YOU ARE HEREBY NOTIFIED that an action has been commenced to foreclose a mortgage on the following real property, lying and being and situated in Pasco County, Florida, more particularly described as follows: LOT 33, BARBY HEIGHTS FIRST ADDITION, ACCORDING TO THE MAP OR PLAT THEREOF AS RECORDED IN PLAT BOOK 9, PAGE 28, OF THE PUBLIC RECORDS OF PASCO COUNTY, FLORIDA more commonly known as 4428 Terry Loop, New Port Richey, FL 34652. This action has been filed against you and you are required to serve a copy of your written defense, if any, upon LOGS LEGAL GROUP LLP, Attorneys for Plaintiff, whose address is 750 Park of Commerce Blvd., Suite 130, Boca Raton, FL 33487, on or before JULY 13, 2026 and file the original with the clerk of this Court either before with service on Plaintiff's attorney or immediately thereafter; otherwise a default will be entered against you for the relief demanded in the Complaint. If you are a person with a disability who needs any accommodation in order to participate in this proceeding, you are entitled, at no cost to you, to the provision of certain assistance. Please contact either the Pasco County Customer Service Center, 8731 Citizens Drive, New Port Richey, FL 34654, (727) 847-2411 (V) or the Pasco County Risk Management Office, 7536 State Street, New Port Richey, FL 34654, (727) 847-8028 (V) at least 7 days before your scheduled court appearance, or immediately upon receiving this notification if the time before the scheduled appearance is less than 7 days; if you are hearing or voice impaired, call 711. WITNESS my hand and seal of this Court on the June 3, 2026. Nikki Alvarez-Sowles, Esq. Circuit and County Courts (SEAL) By: Shakira Ramirez Pagan Deputy Clerk LOGS LEGAL GROUP LLP, Attorneys for Plaintiff, 750 Park of Commerce Blvd., Suite 130, Boca Raton, FL 33487 26-335574 FCO1 SUT June 12, 19, 2026 26-01333P

or otherwise not sui juris. YOU ARE HEREBY NOTIFIED that an action has been commenced to foreclose a mortgage on the following real property, lying and being and situated in Pasco County, Florida, more particularly described as follows: LOT 33, BARBY HEIGHTS FIRST ADDITION, ACCORDING TO THE MAP OR PLAT THEREOF AS RECORDED IN PLAT BOOK 9, PAGE 28, OF THE PUBLIC RECORDS OF PASCO COUNTY, FLORIDA more commonly known as 4428 Terry Loop, New Port Richey, FL 34652. This action has been filed against you and you are required to serve a copy of your written defense, if any, upon LOGS LEGAL GROUP LLP, Attorneys for Plaintiff, whose address is 750 Park of Commerce Blvd., Suite 130, Boca Raton, FL 33487, on or before JULY 13, 2026 and file the original with the clerk of this Court either before with service on Plaintiff's attorney or immediately thereafter; otherwise a default will be entered against you for the relief demanded in the Complaint. If you are a person with a disability who needs any accommodation in order to participate in this proceeding, you are entitled, at no cost to you, to the provision of certain assistance. Please contact either the Pasco County Customer Service Center, 8731 Citizens Drive, New Port Richey, FL 34654, (727) 847-2411 (V) or the Pasco County Risk Management Office, 7536 State Street, New Port Richey, FL 34654, (727) 847-8028 (V) at least 7 days before your scheduled court appearance, or immediately upon receiving this notification if the time before the scheduled appearance is less than 7 days; if you are hearing or voice impaired, call 711. WITNESS my hand and seal of this Court on the June 3, 2026. Nikki Alvarez-Sowles, Esq. Circuit and County Courts (SEAL) By: Shakira Ramirez Pagan Deputy Clerk LOGS LEGAL GROUP LLP, Attorneys for Plaintiff, 750 Park of Commerce Blvd., Suite 130, Boca Raton, FL 33487 26-335574 FCO1 SUT June 12, 19, 2026 26-01333P

or otherwise not sui juris. YOU ARE HEREBY NOTIFIED that an action has been commenced to foreclose a mortgage on the following real property, lying and being and situated in Pasco County, Florida, more particularly described as follows: LOT 33, BARBY HEIGHTS FIRST ADDITION, ACCORDING TO THE MAP OR PLAT THEREOF AS RECORDED IN PLAT BOOK 9, PAGE 28, OF THE PUBLIC RECORDS OF PASCO COUNTY, FLORIDA more commonly known as 4428 Terry Loop, New Port Richey, FL 34652. This action has been filed against you and you are required to serve a copy of your written defense, if any, upon LOGS LEGAL GROUP LLP, Attorneys for Plaintiff, whose address is 750 Park of Commerce Blvd., Suite 130, Boca Raton, FL 33487, on or before JULY 13, 2026 and file the original with the clerk of this Court either before with service on Plaintiff's attorney or immediately thereafter; otherwise a default will be entered against you for the relief demanded in the Complaint. If you are a person with a disability who needs any accommodation in order to participate in this proceeding, you are entitled, at no cost to you, to the provision of certain assistance. Please contact either the Pasco County Customer Service Center, 8731 Citizens Drive, New Port Richey, FL 34654, (727) 847-2411 (V) or the Pasco County Risk Management Office, 7536 State Street, New Port Richey, FL 34654, (727) 847-8028 (V)

--- PUBLIC NOTICES ---

FIRST INSERTION

NOTICE OF FORECLOSURE SALE IN THE CIRCUIT COURT OF THE SIXTH JUDICIAL CIRCUIT IN AND FOR PASCO COUNTY, FLORIDA GENERAL JURISDICTION DIVISION CASE NO. 2025CA003077CAAXES U.S. BANK NATIONAL ASSOCIATION, Plaintiff, vs. DOMINIC J CLARK, et al. Defendant(s).

FEDERAL CREDIT UNION DBA GTE FINANCIAL, CARPENTERS RUN HOMEOWNERS' ASSOCIATION, INC are the Defendant(s). Nikki Alvarez-Sowles, Esq. as the Clerk of the Circuit Court will sell to the highest and best bidder for cash at www.pasco.realforeclose.com, at 11:00 AM, on June 29, 2026, the following described property as set forth in said Final Judgment, to wit:

lis pendens must file a claim in accordance with Florida Statutes, Section 45.031. IMPORTANT AMERICANS WITH DISABILITIES ACT: If you are a person with a disability who needs an accommodation in order to participate in this proceeding, you are entitled, at no cost to you, to the provision of certain assistance. Please contact: Public Information Dept., Pasco County Government Center, 7530 Little Rd., New Port Richey, FL 34654; Phone: 727.847.2411 (voice) in New Port Richey, 727.847.8028 (voice) in Dade City, Or 711 for the hearing impaired. Contact should be initiated at least seven days before the scheduled court appearance, or immediately upon receiving this notification if the time before the scheduled appearance is less than seven days. The court does not provide transportation and

cannot accommodate such requests. Persons with disabilities needing transportation to court should contact their local public transportation providers for information regarding transportation services. Dated this 9 day of June, 2026. ROBERTSON, ANSCHUTZ, SCHNEID, CRANE & PARTNERS, PLLC Attorney for Plaintiff 6409 Congress Ave., Suite 100 Boca Raton, FL 33487 Telephone: 561-241-6901 Facsimile: 561-997-6909 Service Email: flmail@raslg.com By: \S\Danielle Salem Danielle Salem, Esquire Florida Bar No. 0058248 Communication Email: dsalem@raslg.com June 12, 19, 2026 26-01360P

FIRST INSERTION

NOTICE TO CREDITORS IN THE IN THE CIRCUIT COURT OF PASCO COUNTY STATE OF FLORIDA PROBATE DIVISION CASE NO. 2026-CP-000678-PAX WS IN RE: THE ESTATE OF MARY M. MORGAN Deceased. The administration of the estate of MARY M. MORGAN, deceased, whose date of death was January 24, 2026, at Hospice Dr Jay Weil Care Center, New Port Richey, Florida 34653 and whose Social Security Number is xxx-xx-2599., is pending in the 6th Circuit Court for Pasco County, Florida, Probate Division, the address of which is government Center, Little Road, New Port Richey, FL 34656. The names and addresses of the Personal Representative and the Personal Representative's attorney are set forth below.

FIRST INSERTION

NOTICE TO CREDITORS IN THE CIRCUIT COURT FOR Pasco COUNTY, FLORIDA PROBATE DIVISION File No. 2026CP000843CPAXWS IN RE: ESTATE OF Colleen M. Davis Deceased. The administration of the estate of Colleen M. Davis, deceased, whose date of death was March 28th, 2026, is pending in the Circuit Court for Pasco County, Florida, Probate Division, the address of which is PO Drawer 338, New Port Richey, FL 34656-0338. The names and addresses of the personal representative and the personal representative's attorney are set forth below. All creditors of the decedent and other persons having claims or demands against decedent's estate on whom a copy of this notice is required to be served must file their claims with this court ON OR BEFORE THE LATER OF 3 MONTHS AFTER THE TIME OF THE FIRST PUBLICATION OF THIS NOTICE OR 30 DAYS AFTER THE DATE OF SERVICE OF A COPY OF THIS NOTICE ON THEM.

FIRST INSERTION

THE PRESERVE AT SOUTH BRANCH COMMUNITY DEVELOPMENT DISTRICT NOTICE OF REGULAR MEETING OF THE BOARD OF SUPERVISORS

Notice is hereby given that the Board of Supervisors ("Board") of The Preserve at South Branch Community Development District ("District") will hold a regular meeting of its Board on July 2, 2026, at 4:00 p.m. at the SpringHill Suites Tampa Suncoast Parkway, located at 16615 Crosspointe Run, Land O' Lakes, FL 34638. At such time the Board is so authorized and may consider any business that may properly come before it. A copy of the agenda may be obtained at the offices of the District Manager, Vesta District Services, 250 International Parkway, Suite 208, Lake Mary, Florida 32746, Ph: (321) 263-0132 ("District Manager's Office"), during normal business hours.

The meeting is open to the public and will be conducted in accordance with the provisions of Florida law. The meeting may be continued to a date, time, and place to be specified on the record at the meeting. There may be occasions when Board Supervisors or District Staff may participate by speaker telephone.

Any person requiring special accommodations at the meeting because of a disability or physical impairment should contact the District Manager's Office at least forty-eight (48) hours prior to the meeting. If you are hearing or speech impaired, please contact the Florida Relay Service by dialing 7-1-1, or 1-800-955-8771 (TTY) / 1-800-955-8770 (Voice), for aid in contacting the District Manager's Office.

Any person who decides to appeal any decision made by the Board with respect to any matter considered at the meeting is advised that person will need a record of proceedings and that accordingly, the person may need to ensure that a verbatim record of the proceedings is made, including the testimony and evidence upon which such appeal is to be based.

District Manager June 12, 2026 26-01352P

FIRST INSERTION

NOTICE THE CITY COUNCIL OF THE CITY OF ZEPHYRHILLS, FLORIDA WILL CONDUCT A PUBLIC HEARING ON THE FOLLOWING:

RESOLUTION NO. 870-26

A RESOLUTION OF THE CITY COUNCIL OF THE CITY OF ZEPHYRHILLS, FLORIDA, AMENDING THE PERMIT AND SAFETY FEE SCHEDULE.

The public hearing will be held on June 22, 2026 at 6:00 p.m. in Council Chambers, City Hall, 5335 8th Street, Zephyrhills, Florida. The full text of the ordinance is posted in City Hall and may be inspected by the public from 8:00 a.m. to 5:00 p.m. weekdays. All interested parties may appear at the meeting and may be heard with respect to the proposed ordinance or may submit written comments to City Council, 5335 8th Street, Zephyrhills, FL 33542.

* PLEASE NOTE: This is a Public Meeting. Should any interested party seek to appeal any decision made by the Council with respect to any matter considered at such meeting or hearing, he or she will need a record of the proceedings, and that, for such purpose, he or she may need to ensure that a verbatim record of the proceeding is made, which record includes the testimony and evidence upon which the appeal is to be based. F.S. 286.0105. If you are a person with a disability which requires reasonable accommodation in order to participate in this meeting, please contact the City Clerk at 813-780-0000 at least 48 hours prior to the public hearing. A.D.A. and F.S. 286.26.

286.0105 June 12, 2026 26-01365P

FIRST INSERTION

NOTICE THE CITY COUNCIL OF THE CITY OF ZEPHYRHILLS, FLORIDA WILL CONDUCT A PUBLIC HEARING ON THE FOLLOWING:

ORDINANCE NO. 1524-26

AN ORDINANCE OF THE CITY OF ZEPHYRHILLS, FLORIDA, AMENDING THE CITY OF ZEPHYRHILLS CODE OF ORDINANCES, REPEALING AND REPLACING SECTION 121: MOBILE FOOD VENDING; AMENDING THE REGULATIONS OF MOBILE FOOD OPERATIONS; ESTABLISHING REGULATIONS FOR TEMPORARY OR AUXILIARY KITCHENS ASSOCIATED WITH BARS OR TAVERNS; PROVIDING FOR APPLICABILITY, REPEALER, SEVERABILITY, INCLUSION IN THE CODE, SCRIVENER'S ERROR AND AN EFFECTIVE DATE.

The public hearing will be held on June 22, 2026 at 6:00 p.m. in Council Chambers, City Hall, 5335 8th Street, Zephyrhills, Florida. The full text of the ordinance is posted in City Hall and may be inspected by the public from 8:00 a.m. to 5:00 p.m. weekdays. All interested parties may appear at the meeting and may be heard with respect to the proposed ordinance or may submit written comments to City Council, 5335 8th Street, Zephyrhills, FL 33542.

* PLEASE NOTE: This is a Public Meeting. Should any interested party seek to appeal any decision made by the Council with respect to any matter considered at such meeting or hearing, he or she will need a record of the proceedings, and that, for such purpose, he or she may need to ensure that a verbatim record of the proceeding is made, which record includes the testimony and evidence upon which the appeal is to be based. F.S. 286.0105. If you are a person with a disability which requires reasonable accommodation in order to participate in this meeting, please contact the City Clerk at 813-780-0000 at least 48 hours prior to the public hearing. A.D.A. and F.S. 286.26.

286.0105 June 12, 2026 26-01350P

FIRST INSERTION

NOTICE THE CITY COUNCIL OF THE CITY OF ZEPHYRHILLS, FLORIDA WILL CONDUCT A PUBLIC HEARING ON THE FOLLOWING:

ORDINANCE NO. 1525-26

AN ORDINANCE BY THE CITY COUNCIL OF THE CITY OF ZEPHYRHILLS, FLORIDA CREATING SECTION 8.17.00 OF THE LAND DEVELOPMENT CODE, LARGE-FORMAT INDUSTRIAL BUILDING SIGNAGE; PROVIDING FOR REPEALER, CODIFICATION, SEVERABILITY, AND AN EFFECTIVE DATE.

The public hearing will be held on June 22, 2026 at 6:00 p.m. in Council Chambers, City Hall, 5335 8th Street, Zephyrhills, Florida. The full text of the ordinance is posted in City Hall and may be inspected by the public from 8:00 a.m. to 5:00 p.m. weekdays. All interested parties may appear at the meeting and may be heard with respect to the proposed ordinance or may submit written comments to City Council, 5335 8th Street, Zephyrhills, FL 33542.

* PLEASE NOTE: This is a Public Meeting. Should any interested party seek to appeal any decision made by the Council with respect to any matter considered at such meeting or hearing, he or she will need a record of the proceedings, and that, for such purpose, he or she may need to ensure that a verbatim record of the proceeding is made, which record includes the testimony and evidence upon which the appeal is to be based. F.S. 286.0105. If you are a person with a disability which requires reasonable accommodation in order to participate in this meeting, please contact the City Clerk at 813-780-0000 at least 48 hours prior to the public hearing. A.D.A. and F.S. 286.26.

286.0105 June 12, 2026 26-01351P

FIRST INSERTION

NOTICE THE CITY COUNCIL OF THE CITY OF ZEPHYRHILLS, FLORIDA WILL CONDUCT A PUBLIC HEARING ON THE FOLLOWING:

ORDINANCE NO. 1523-26

AN ORDINANCE OF THE CITY OF ZEPHYRHILLS, FLORIDA ESTABLISHING A TEMPORARY MORATORIUM ON THE ACCEPTANCE, PROCESSING, REVIEW, APPROVAL, OR ISSUANCE OF BUILDING PERMITS, REZONINGS, SITE PLANS, CONDITIONAL USE APPROVALS, VARIANCES, COMPREHENSIVE PLAN AMENDMENTS, OR OTHER CITY APPROVALS FOR THE CONSTRUCTION, ESTABLISHMENT, EXPANSION, OR INTENSIFICATION OF DATA CENTERS, DATA CENTER FACILITIES, LARGE-SCALE DATA CENTERS, AND LARGE LOAD CUSTOMER FACILITIES WITHIN THE MUNICIPAL LIMITS OF CITY OF ZEPHYRHILLS; PROVIDING LEGISLATIVE FINDINGS OF FACT; PROVIDING DEFINITIONS; DIRECTING CITY STAFF TO REVIEW AND PREPARE LAND DEVELOPMENT CODE AND RELATED REGULATORY AMENDMENTS; PROVIDING FOR SEVERABILITY, REPEALER, AND AN EFFECTIVE DATE.

The public hearing will be held on June 22, 2026 at 6:00 p.m. in Council Chambers, City Hall, 5335 8th Street, Zephyrhills, Florida. The full text of the ordinance is posted in City Hall and may be inspected by the public from 8:00 a.m. to 5:00 p.m. weekdays. All interested parties may appear at the meeting and may be heard with respect to the proposed ordinance or may submit written comments to City Council, 5335 8th Street, Zephyrhills, FL 33542.

* PLEASE NOTE: This is a Public Meeting. Should any interested party seek to appeal any decision made by the Council with respect to any matter considered at such meeting or hearing, he or she will need a record of the proceedings, and that, for such purpose, he or she may need to ensure that a verbatim record of the proceeding is made, which record includes the testimony and evidence upon which the appeal is to be based. F.S. 286.0105. If you are a person with a disability which requires reasonable accommodation in order to participate in this meeting, please contact the City Clerk at 813-780-0000 at least 48 hours prior to the public hearing. A.D.A. and F.S. 286.26.

286.0105 June 12, 2026 26-01349P

FIRST INSERTION

EPPERSON NORTH COMMUNITY DEVELOPMENT DISTRICT NOTICE OF BOARD OF SUPERVISORS' CLOSED ATTORNEY-CLIENT MEETING

Notice is hereby given that the Board of Supervisors ("Board") of the Epperson North Community Development District ("District") will hold a closed attorney-client meeting on Tuesday, June 23, 2026, at 5:00 p.m. at Epperson North Lakehouse, 9045 Ivy Stark Blvd., Wesley Chapel, Florida 33545.

The attorney-client session, which will be closed to the public pursuant to Section 286.011(8), Florida Statutes, relates to discussion of settlement negotiations and strategy related to litigation in the matters of Floralawn, Inc. vs. Epperson North Community Development District, Case Number 2025-CC-008482-ES, Epperson North, LLC v. Epperson North Community Development District, et al, Case Number 2025-CA-1113, and Epperson North Community Development District v. Heidt Design, LLC, Case Number 2020-CA-2703, all cases pending in the Circuit and/or Courts for Pasco County. The subject matter of the closed attorney-client session shall be confined to settlement negotiations or strategy sessions related to ongoing litigation.

The persons attending the attorney-client session shall be limited to the following: Angel Petti Rosenberg, Esq., Patrick Dervishi, Esq., Henry Paul, Esq., Guy Shir, Esq., Carlos Alvarez, Supervisor, Garrett Marshall, Supervisor, Jenna O'Brien, Supervisor, Jessica Pisculli, Supervisor, and a court reporter. The attorney-client session is estimated to last 3 hours and will be transcribed by a court reporter.

A copy of the agenda may be obtained by visiting the District's website at https://www.eppersonnorthcdd.org.

There may be occasions when one or more Supervisors or staff will participate by telephone. Pursuant to provisions of the Americans with Disabilities Act, any person requiring special accommodations at this meeting because of a disability or physical impairment should contact the District Office at (904) 436-6270 at least three business days prior to the meeting. If you are hearing or speech impaired, please contact the Florida Relay Service by dialing 7-1-1, or 1-800-955-8771 (TTY) / 1-800-955-8770 (Voice), for assistance in contacting the District Office.

A person who decides to appeal any decision made at the meeting with respect to any matter considered at the meeting is advised that person will need a record of the proceedings and that accordingly, the person may need to ensure that a verbatim record of the proceedings is made, including the testimony and evidence upon which such appeal is to be based.

District Manager June 12, 2026 26-01361P

FIRST INSERTION

NOTICE OF FORECLOSURE SALE IN THE CIRCUIT COURT OF THE SIXTH JUDICIAL CIRCUIT OF FLORIDA IN AND FOR PASCO COUNTY GENERAL JURISDICTION DIVISION CASE NO. 2025CA000648CAAXWS

NEWREZ LLC D/B/A SHELLPOINT MORTGAGE SERVICING, Plaintiff, vs. DAVID W. CHEELY A/K/A DAVID CHEELY, et al., Defendant.

NOTICE IS HEREBY GIVEN pursuant to a Summary Final Judgment of Foreclosure entered May 04, 2026 in Civil Case No. 2025CA000648CAAXWS of the Circuit Court of the SIXTH JUDICIAL CIRCUIT in and for Pasco County, Dade City, Florida, wherein NEWREZ LLC D/B/A SHELLPOINT MORTGAGE SERVICING is Plaintiff and David W. Cheely a/k/a David Cheely, et al., are Defendants, the Clerk of Court, NIKKI ALVAREZ-SOWLES, ESQ., will sell to the highest and best bidder for cash electronically at www.pasco.realforeclose.com in accordance with Chapter 45, Florida Statutes on the 7th day of July, 2026 at 11:00 AM on the following described property as set forth in said Summary Final Judgment, to-wit: Lot 78, The Glen at River Ridge, Unit Three, according to the plat thereof as recorded in Plat Book 24, at Pages 38-40, of the Public Records of Pasco County, Florida.

Any person claiming an interest in the surplus from the sale, if any, other than the property owner as of the date of the lis pendens, must file a claim before the clerk reports the surplus as unclaimed. If you are a person with a disability who needs any accommodation in order to participate in this proceeding, you are entitled, at no cost to you to the provision of certain assistance. Within two (2) working days of your receipt of this (describe notice/order) please contact the Public Information Dept., Pasco County Government Center, 7530 Little Rd., New Port Richey, FL 34654; (727) 847-8110 (V) in New Port Richey; (352) 521-4274, ext. 8110 (V) in Dade City; via 1-800-955-8771 if you are hearing impaired. The court does not provide transportation and cannot accommodate for this service. Persons with disabilities needing transportation to court should contact their local public transportation providers for information regarding disabled transportation services.

/s/Robyn Katz Robyn Katz, Esq. McCalla Raymer Leibert Pierce, LLP Attorney for Plaintiff 225 East Robinson Street, Suite 155 Orlando, FL 32801 Phone: (407) 674-1850 Fax: (321) 248-0420 Email: MRSservice@mccalla.com Fla. Bar No.: 146803 25-11291FL June 12, 19, 2026 26-01367P



Who benefits from legal notices?

You do. Legal notices are required because a government body or corporation wants to take action that can affect individuals and the public at large.

When the government is about to change your life, or your property or assets are about to be taken, public notices in newspapers serve to alert those affected.

--- ACTIONS / SALES ---

FIRST INSERTION

PETITION FOR ADMINISTRATION
IN THE CIRCUIT COURT OF THE SIXTH JUDICIAL
CIRCUIT IN AND FOR PASCO COUNTY, FLORIDA
PROBATE DIVISION
Case No. 26-CP-891
IN THE ESTATE OF:
DOUGLAS T. O'CONNOR
Decedent.

Petitioner, MARK O'CONNOR, alleges:

1. Petitioner has an interest in the above estate as Brother. Petitioner's address is 2 Emerson Point New Rochelle, NY 10808, and the name and office address of petitioner's attorney are set forth at the end of this petition.

2. Decedent, DOUGLAS T. O'CONNOR, whose last known address was 2842 Tanglewyde Dr, Land O' Lakes Fl 34638 and the last four digits of whose social security number are 9445, died on April 21, 2026, at Aventura Health Wesley Chapel. On the date of death decedent was domiciled in Pasco County, Florida.

3. So far as is known, the names of the beneficiaries of this estate and of the decedent's surviving spouse, if any, their addresses and relationships to decedent, and the years of birth of any who are minors, are:

NAME	ADDRESS	RELATIONSHIP	YEAR OF BIRTH (if Minor)
Mark O'Connor	2 Emerson Point	Brother New Rochelle, NY 10808	
Dorothy J. Capuano	19707 Post Island Loop Land O'Lakes Fl, 34638	Friend	

4. Venue of this proceeding is in this county because it was the county of the decedent's residence at the time of the decedent's death.

5. Petitioner, MARK G O'CONNOR, whose address is 2 Emerson Point New Rochelle, Ny 10808 is qualified under the laws of the State of Florida to serve as personal representative of the decedent's estate and is entitled to preference in appointment as personal representative because all of the heirs of the estate have consented to Petitioner as personal representative. The consents have been filed with this Petition. 6. The nature and approximate value of the assets in this estate are:

NATURE OF ASSETS	APPROXIMATE VALUE
Investment Account-Chase Bank Account	
Retail Bank- Checking, Savings, CD's and IRA (information to follow when received)	UNKNOWN

- This estate will not be required to file a federal estate tax return.
- Domiciliary or principal proceedings are not known to be pending in another state or country.
- The decedent's last will dated November 03, 2016, and codicils are in the pos-

session of the court or accompanies this petition. An authenticated copy of a will and/or codicil deposited with or probated in another jurisdiction accompanies this petition.

An authenticated copy of a notarial will or codicil, the original of which is in the possession of a foreign notary, accompanies this petition.

10. Petitioner is unaware of any unrevoked will or codicil of decedent other than as set forth in paragraph 9.

11. The nature and approximate value of the assets in the estate are:

ASSETS	ESTIMATED VALUE
Exempt Homestead:2842 Tanglewyde Dr, Land O Lakes, FL 34638	\$331,100
Lot 26, Block28, OAKSTEAD PARCELS, as per plat thereof, recorded in Plat Book48, Page 1 27-136, of the Public Records of Pasco County, Florida Subject, however, to all covenants, conditions, restrictions, reservations, limitations, easements and to applicable zoning ordinances and/or restrictions and prohibitions imposed by governmental authorities, if any.	

EXEMPT pursuant to Article X, Section 4 of Fl. Const
Exempt Personal Property: Up to \$20,000
Household furniture, appliances, knickknacks, etc.

Exempt pursuant to FL STAT 732.402.
Exempt Personal Vehicle: \$51,970
2024 Genesis SUV GV80 VIN# KMHCEC4RU148383

Exempt pursuant to FL STAT 732.402

Whereof, Petitioner respectfully requests that the decedent's will be admitted to probate and that MARK G. O'CONNOR be appointed personal representative of the estate of the decedent.

Under penalties of perjury, I declare that I have read the foregoing, and the facts alleged are true, to the best of my knowledge and belief.

Signed on this 4th day of May, 2026.

MARK G. O'CONNOR
Petitioner

/s/ChristineBehrman de Colindres
CHRISTINE BEHRMANDE COLINDRES
Law Office of Christine Behrman de Colindres, PLLC
11307 Little Road
New Port Richey, FL 34654
Bar License #1024659
Telephone: 727-277-8997; 727-378-4553
Email: christine@christinebehrmandecolindreslaw.com
carol@christinebehrmandecolindreslaw.com
June 12, 19, 2026

26-001355P

FIRST INSERTION

NOTICE OF FORECLOSURE SALE
IN THE CIRCUIT COURT OF THE
SIXTH JUDICIAL CIRCUIT, IN AND
FOR PASCO COUNTY, FLORIDA
GENERAL JURISDICTION
DIVISION

Case No. 2025CA002752CAAXWS
Freedom Mortgage Corporation,
Plaintiff, vs.
Ashley Perrini a/k/a Ashley Trishelle Perrini f/k/a Ashley Martinez, et al.,
Defendants.

NOTICE IS HEREBY GIVEN pursuant to the Final Judgment and/or Order Rescheduling Foreclosure Sale, entered in Case No. 2025CA002752CAAXWS of the Circuit Court of the SIXTH Judicial Circuit, in and for Pasco County, Florida, wherein Freedom Mortgage Corporation is the Plaintiff and Ashley Perrini a/k/a Ashley Trishelle Perrini f/k/a Ashley Martinez ; Edwin Martinez a/k/a Edwin Wilson Martinez; United States of America on behalf of the Secretary of Housing and Urban Development are the Defendants, that Nikki Alvarez-Sowles, Pasco County Clerk of Court will sell to the highest and best bidder for cash at, www.pasco.realforeclose.com, beginning at 11:00 AM on the 3rd day of August, 2026, the following described property as set forth in said Final Judgment, to wit:

LOT 62, ALOHA GARDENS UNIT ONE, AS PER PLAT THEREOF RECORDED IN PLAT BOOK 9, PAGES 115 AND 116, OF THE PUBLIC RECORDS OF PASCO COUNTY, FLORIDA.
TAX ID:
30-26-16-0270-00000-0620

Any person claiming an interest in the

surplus from the sale, if any, other than the property owner as of the date of the lis pendens must file a claim before the clerk reports the surplus as unclaimed.

If you are a person with a disability who needs an accommodation in order to participate in this proceeding, you are entitled, at no cost to you, to the provision of certain assistance. Please contact: Public Information Dept., Pasco County Government Center, 7530 Little Rd., New Port Richey, FL 34654; Phone: 727.847.8110 (voice) in New Port Richey, 352.521.4274, ext 8110 (voice) in Dade City, Or 711 for the hearing impaired. Contact should be initiated at least seven days before the scheduled court appearance, or immediately upon receiving this notification if the time before the scheduled appearance is less than seven days. The court does not provide transportation and cannot accommodate such requests. Persons with disabilities needing transportation to court should contact their local public transportation providers for information regarding transportation services.

Dated this 9th day of June, 2026.
BROCK & SCOTT, PLLC
Attorney for Plaintiff
4919 Memorial Hwy,
Suite 135
Tampa, FL 33634
Phone: (954) 618-6955
Fax: (954) 618-6954
FLCourtDocs@brockandscott.com
By /s/Justin J. Kelley
Justin J. Kelley, Esq.
Florida Bar No. 32106
File # 25-F02402
June 12, 19, 2026 26-01353P

FIRST INSERTION

NOTICE

THE CITY COUNCIL OF THE CITY OF ZEPHYRHILLS, FLORIDA
WILL CONDUCT A PUBLIC HEARING ON THE FOLLOWING:

RESOLUTION NO. 871-26

A RESOLUTION OF THE CITY COUNCIL OF THE CITY OF ZEPHYRHILLS, FLORIDA, REGARDING THE ESTABLISHMENT OF STORMWATER UTILITY ASSESSMENT RATES.

The public hearing will be held on June 22, 2026 at 6:00 p.m. in Council Chambers, City Hall, 5335 8th Street, Zephyrhills, Florida. The full text of the ordinance is posted in City Hall and may be inspected by the public from 8:00 a.m. to 5:00 p.m. weekdays. All interested parties may appear at the meeting and may be heard with respect to the proposed ordinance or may submit written comments to City Council, 5335 8th Street, Zephyrhills, FL 33542.

* PLEASE NOTE: This is a Public Meeting. Should any interested party seek to appeal any decision made by the Council with respect to any matter considered at such meeting or hearing, he or she will need a record of the proceedings, and that, for such purpose, he or she may need to ensure that a verbatim record of the proceeding is made, which record includes the testimony and evidence upon which the appeal is to be based. F.S. 286.0105. If you are a person with a disability which requires reasonable accommodation in order to participate in this meeting, please contact the City Clerk at 813-780-0000 at least 48 hours prior to the public hearing. A.D.A. and F.S. 286.26.
286.0105
June 12, 2026 26-01369P

FIRST INSERTION

NOTICE

THE CITY COUNCIL OF THE CITY OF ZEPHYRHILLS, FLORIDA
WILL CONDUCT A PUBLIC HEARING ON THE FOLLOWING:

RESOLUTION NO. 872-26

A RESOLUTION OF THE CITY COUNCIL OF THE CITY OF ZEPHYRHILLS, FLORIDA, APPROVING THE STORMWATER UTILITY ASSESSMENT MITIGATION CREDIT POLICY MANUAL AND PROVIDING AN EFFECTIVE DATE.

The public hearing will be held on June 22, 2026 at 6:00 p.m. in Council Chambers, City Hall, 5335 8th Street, Zephyrhills, Florida. The full text of the ordinance is posted in City Hall and may be inspected by the public from 8:00 a.m. to 5:00 p.m. weekdays. All interested parties may appear at the meeting and may be heard with respect to the proposed ordinance or may submit written comments to City Council, 5335 8th Street, Zephyrhills, FL 33542.

* PLEASE NOTE: This is a Public Meeting. Should any interested party seek to appeal any decision made by the Council with respect to any matter considered at such meeting or hearing, he or she will need a record of the proceedings, and that, for such purpose, he or she may need to ensure that a verbatim record of the proceeding is made, which record includes the testimony and evidence upon which the appeal is to be based. F.S. 286.0105. If you are a person with a disability which requires reasonable accommodation in order to participate in this meeting, please contact the City Clerk at 813-780-0000 at least 48 hours prior to the public hearing. A.D.A. and F.S. 286.26.
286.0105
June 12, 2026 26-01370P

FIRST INSERTION

NOTICE OF SALE PURSUANT TO CHAPTER 45,

FLORIDA STATUTES

IN THE CIRCUIT COURT OF THE SIXTH JUDICIAL CIRCUIT, IN AND FOR PASCO COUNTY, FLORIDA

CASE NO.: 2025CA002009
SILVERADO RANCH NORTH HOMEOWNERS ASSOCIATION, INC.,

Plaintiff, vs.
YOHANNES H. DABERA, et al.,
Defendant(s).

Notice is given that pursuant to the Final Judgment of Foreclosure dated 6/5/2026, in Case No.: 2025CA002009 of the Circuit Court in and for Pasco County, Florida, wherein SILVERADO RANCH NORTH HOMEOWNERS ASSOCIATION, INC., is the Plaintiff and YOHANNES H. DABERA, is/are the Defendant(s). Nikki Alvarez-Sowles, Esquire, the Clerk of Court for Pasco County, Florida will sell to the highest and best bidder for cash at 11:00 a.m., at https://www.pasco.realforeclose.com, in accordance with Section 45.031, Florida Statutes, on 7/20/2026, the following described property set forth in the Final Judgment of Foreclosure:

Lot 20, Block 16, SILVERADO RANCH SUBDIVISION PHASES 10B AND 11C, according to the plat as recorded in Plat Book 82, Pages 72 through 75, of the Public Records of Pasco County, Florida.

Any person claiming an interest in the surplus from the sale, if any, other than the property owner as of the date of the lis pendens must file a claim before the clerk reports the surplus as unclaimed.

IF YOU ARE A PERSON WITH A DISABILITY WHO NEEDS ANY ACCOMMODATION IN ORDER TO PARTICIPATE IN THIS PROCEEDING, YOU ARE ENTITLED, AT NO COST TO YOU, TO THE PROVISION OF CERTAIN ASSISTANCE. PLEASE CONTACT EITHER THE PASCO COUNTY CUSTOMER SERVICE CENTER, 8731 CITIZENS DRIVE, NEW PORT RICHEY, FL 34654, (727) 847-2411 (V) OR THE PASCO COUNTY RISK MANAGEMENT OFFICE, 7536 STATE STREET, NEW PORT RICHEY, FL 34654, (727) 847-8028 (V) AT LEAST 7 DAYS BEFORE YOUR SCHEDULED COURT APPEARANCE, OR IMMEDIATELY UPON RECEIVING THIS NOTIFICATION IF THE TIME BEFORE THE SCHEDULED APPEARANCE IS LESS THAN 7 DAYS; IF YOU ARE HEARING OR VOICE IMPAIRED, CALL 711.

DATED: June 10, 2026
By: /s/Chad Sweeting
Chad Sweeting, Esquire
Florida Bar No.: 93642
ARIAS BOSINGER, PLLC
280 W. Canton Avenue, Suite 330
Winter Park, Florida 32789
(407) 636-2549
June 12, 19, 2026 26-001362P

NEW NEIGHBORS

WE ALL LOVE DOGS, but when there are plans to put a new kennel on the property next to your house...

WOULDN'T YOU WANT TO KNOW?

BE INFORMED

Read public notices to find out what's going on in your community.

FIND PUBLIC NOTICES IN THIS NEWSPAPER OR ONLINE

PUBLIC NOTICE DAY JAN 24 2018

FLORIDA PUBLIC NOTICES ASSOCIATION

FLORIDA PUBLIC NOTICES
www.floridapublicnotices.com

FLORIDA'S NEWSPAPER FOR THE C-SIDE
Business Observer

FloridaPublicNotices.com

Q&A

Who benefits from legal notices?

You do. Legal notices are required because a government body or corporation wants to take action that can affect individuals and the public at large.

When the government is about to change your life, or your property or assets are about to be taken, public notices in newspapers serve to alert those affected.

LV18237_V13

123 456 Done

floridapublicnotices.com

CHECK OUT YOUR LEGAL NOTICES

LV20890_V2

Why Public Notice Should Remain in Newspapers

Along with open meeting and freedom of information laws, public notice is an essential element of the **three-legged stool of government transparency**

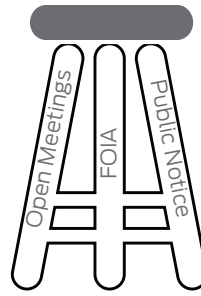

This is not about “newspapers vs the internet”.

It’s newspapers *and* newspaper websites vs government websites

and newspaper websites have a much larger audience. Moving notice from newspapers to government websites would **reduce the presence of public notices on the internet**



Requiring independent, third-party newspapers to ensure that public notices run in accordance with the law helps

prevent government officials from hiding information

they would prefer the public not to see

Since the first U.S. Congress, public officials have understood that newspapers are the best medium to notify the public about official matters because they contain the **essential elements of public notice:**



Accessibility



Independence



Verifiability



Archivability

Publishing notices on the internet is neither cheap nor free

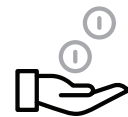

Newspapers remain the primary vehicle for public notice in all 50 states



Types Of Public Notices

Citizen Participation Notices



Government Meetings and Hearings



Land and Water Use



Meeting Minutes or Summaries



Creation of Special Tax Districts



Agency Proposals



School District Reports



Proposed Budgets and Tax Rates



Zoning, Annexation and Land Use Changes

Commercial Notices



Unclaimed Property, Banks or Governments



Delinquent Tax Lists, Tax Deed Sales



Government Property Sales



Permit and License Applications

Court Notices



Mortgage Foreclosures



Name Changes



Probate Rulings



Divorces and Adoptions



Orders to Appear in Court

Stay Informed, It’s Your Right to Know.

For legal notice listings go to: Legals.BusinessObserverFL.com

To publish your legal notice call: 941-906-9386 or Legal@BusinessObserverFL.com

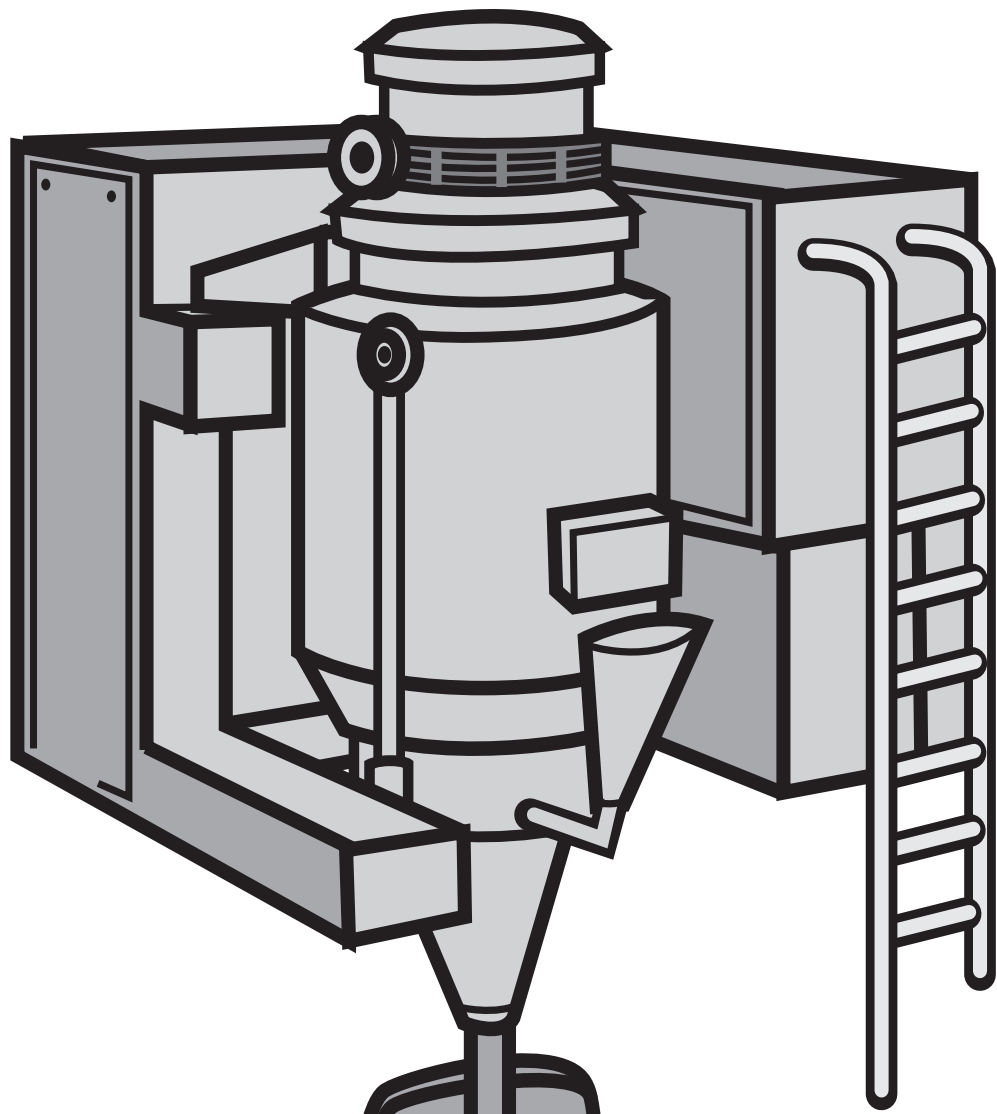

TOM SMITH AND HIS INCREDIBLE BREAD MACHINE

By R.W. Grant

Illustrations by Austin McKinley

This is the legend of a man whose name
Was a household word: a man whose fame
Burst on the world like an atom bomb.
Smith was his last name; first name: Tom.

The argument goes on today.
"He was a villain," some will say.
"No! A hero!" others declare.
Or was he both? Well, I despair;
The fight will last 'til kingdom come;
Was Smith a hero? Or was Smith a bum?
So, listen to the story and it's up to you
To decide for yourself as to which is true!

Now, Smith, an inventor, had specialized
In toys. So people were surprised
When they found that he instead
Of making toys, was baking bread!
The news was flashed by CBS
Of his incredible success.
Then NBC jumped in in force,
Followed by the Times, of course.
The reason for their rapt attention,
The nature of his new invention,
The way to make bread he'd conceived
Cost less than people could believe!
And not just make it! This device
Could in addition wrap and slice!
The price per loaf, one loaf or many:
The miniscule sum of under one penny!

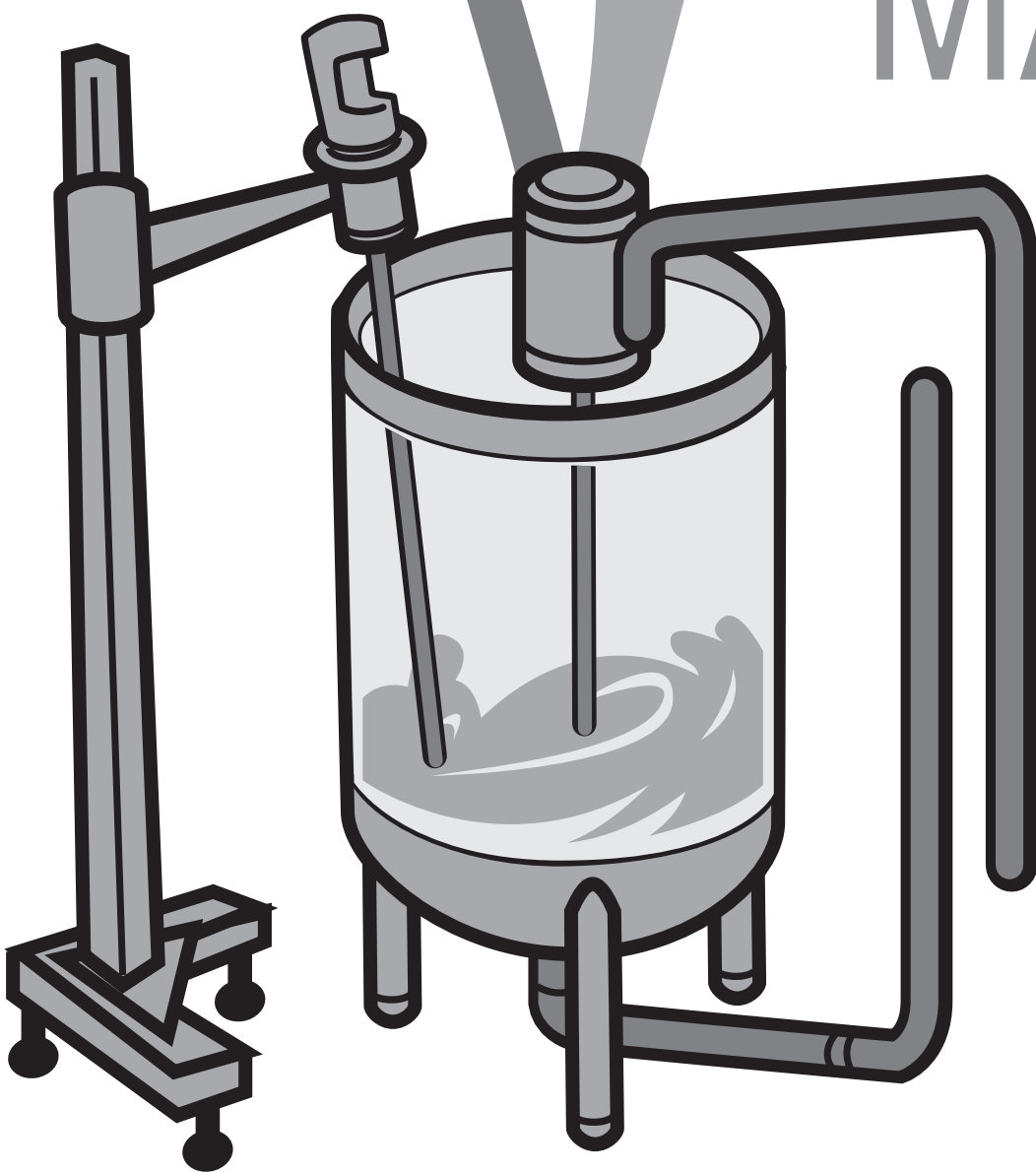

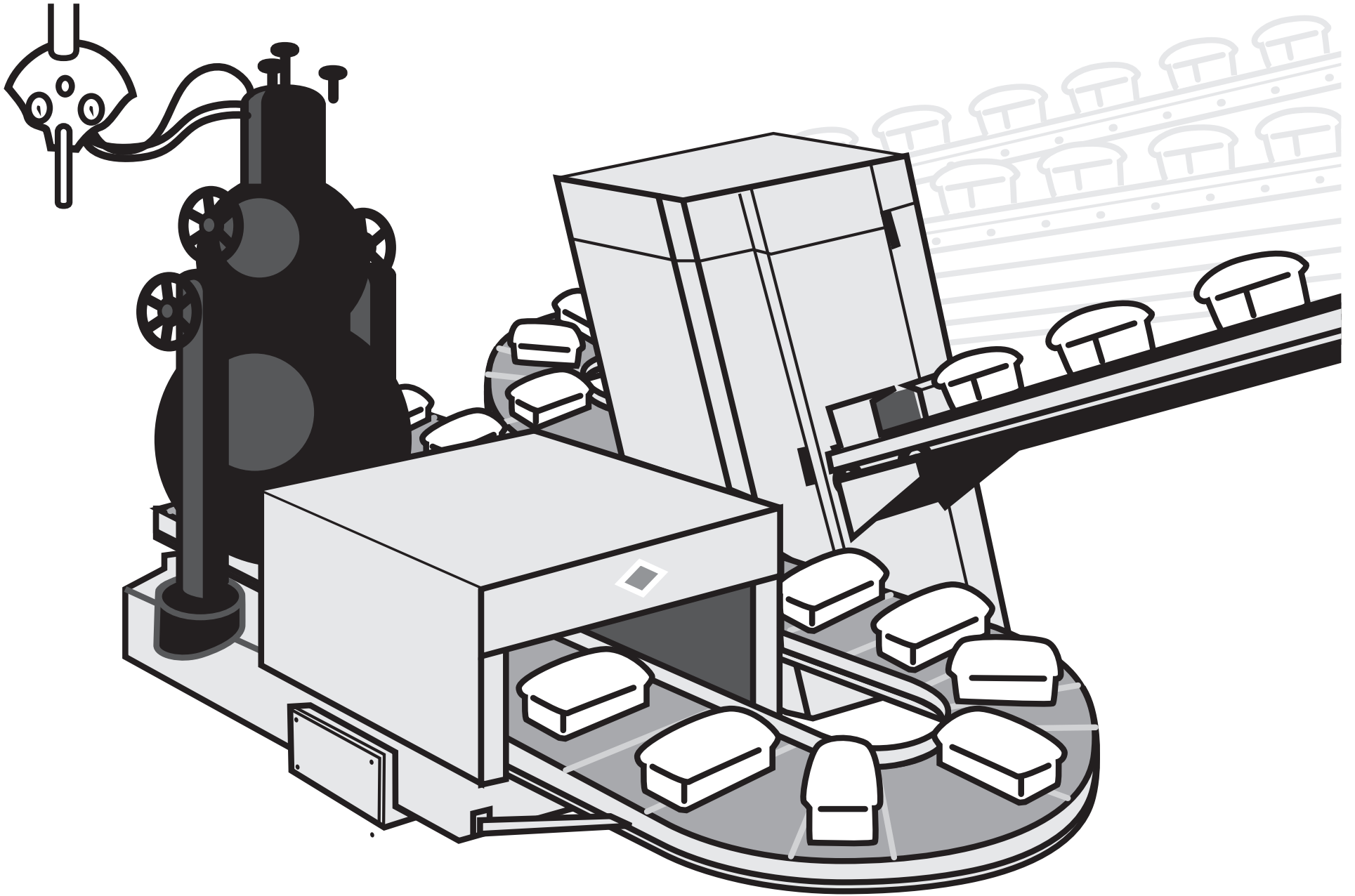

Can you imagine what this meant?
Can you comprehend the consequent?
The first time yet the world well fed!
And all because of Tom Smith's bread!

Not the last to see the repercussions
Were the Red Chinese, and, of course, the
Russians,
For Capitalist bread in such array

Threw the whole red block into black dis-
may!
Nonetheless, the world soon found
That bread was plentiful the world
around.
Thanks to Smith and all that bread,
A grateful world was at last well fed!

But isn't it a wondrous thing
How quickly fame is flown?
Smith, the hero of today
Tomorrow, scarcely known!
Yes, the fickle years passed by.
Smith was a billionaire.

But Smith himself was now forgot,
Though bread was everywhere.
People, asked from where it came,
Would very seldom know.

They would simply eat and ask,
'Was not it always so?'

However, Smith cared not a bit,
For millions ate his bread,
And "Everything is fine," thought he.
'I'm rich and they are fed!'

Everything was fine, he thought?
He reckoned not with fate.
Note the sequence of events
Starting on the date
On which inflation took its toll,
And to a slight extent,
The price on every loaf increased:
It went to one full cent!

A sharp reaction quickly came.
People were concerned.
White House aide expressed dismay.
Then the nation learned
That Russia lodged a sharp protest.
India did the same.
"Exploitation of the Poor!"
Yet, who was there to blame?

And though the clamor ebbed and flowed,
All that Tom would say
Was that it was but foolish talk.
Which soon would die away.
And it appeared that he was right.
Though on and on it ran,
The argument went 'round and 'round
But stopped where it began.

There it stopped, and people cried,
"For heaven's sake, we can't decide!
It's relative! Beyond dispute,
There's no such thing as 'absolute'!
And though we try with all our might,
Since nothing's ever black or white,
All that we can finally say is
'Everything one shade of grey is!'
So people cried out, "Give us light!
We can't tell what's wrong from right!"

To comprehend confusion,
We seek wisdom at its source.
To whom, then did the people turn?
The Intellectuals, of course!

And what could be a better time
For them to take the lead,
Than at their International Conference
On Inhumanity and Greed.
For at this weighty conference,
Once each year we face
The moral conscience of the world—
Concentrated in one place.

At that mighty conference were
A thousand, more or less,
Of intellectuals and bureaucrats,
And those who write the press.
And from Yale and Harvard
The professors; all aware
The fate of Smith would now be known.
Excitement filled the air!

"The time has come," the chairman said
"To speak of many things:
Of duty, bread and selfishness,
And the evil that it brings.
For, speaking thus we can amend
That irony of fate
That gives to unenlightened minds
The power to create.



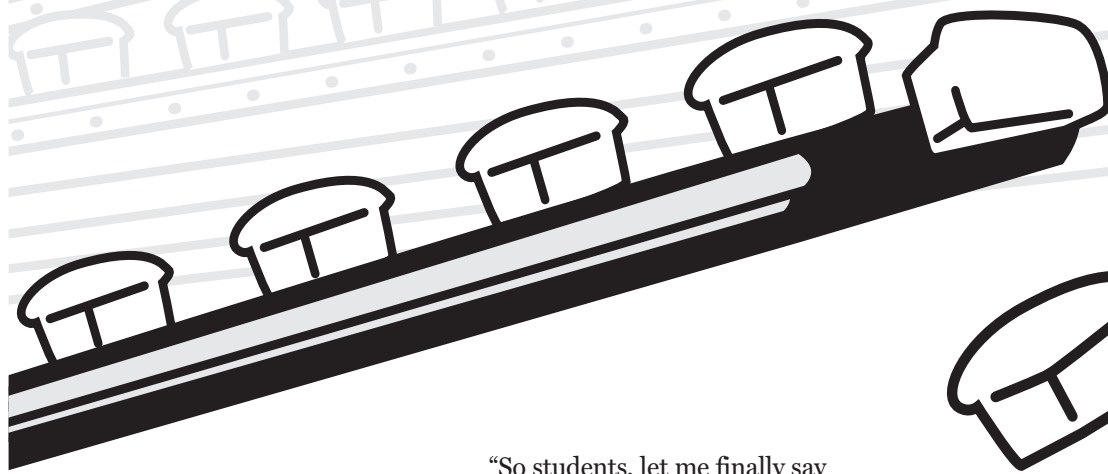

"Since reason tells us that it can't,
Therefore let us start
Not by thinking with the mind,
But only with the heart!
Since we believe in people, then,"
At last the chairman said,
'We must meet our obligation
To see that they are fed!"

And so it went, one by one,
Denouncing private greed;
Denouncing those who'd profit thus
From other people's need!

Then, suddenly each breath was held,
For there was none more wise
Than the nation's foremost Pundit
Who now rose to summarize:

"My friends," he said, (they all
exhaled)
'We see in these events
The flouting of the Higher Law—
And its consequence.
We must again remind ourselves
Just why mankind is cursed:
Because we fail to realize
Society comes first!

"Smith placed himself above the
group
To profit from his brothers.
He failed to see the Greater Good,
Is Service, friends, to Others!"

With boldness and with vision,
then,
They ratified the motion
To dedicate to all mankind
Smith's bread—and their devotion!

The conference finally ended.
It had been a huge success.
The intellectuals had spoken.
Now others did the rest.

The professors joined in all the
fuss,
And one was heard to lecture thus:
(For clarity, he spoke in terms
Of Mother Nature, birds and worms):

"That early birds should get the worm
Is clearly quite unfair.
Wouldn't it much nicer be
If all of them would share?
But selfishness and private greed

Seem part of nature's plan,
Which Mother Nature has decreed
For bird. But also Man?
The system which I question now,
As you are well aware,
(I'm sure you've heard the term
before
Is Business, Laissez-Faire!

"So students, let me finally say
That we must find a nobler way.
So, let us fix the race that all
May finish side-by-side;
The playing field forever flat,
The score forever tied.
To achieve this end, of course,
We turn to government—and force.
So, if we have to bring Smith do
As indeed we should,
I'm sure you will agree with me,
It's for the Greater Good!"

Comments in the nation's press
Now scorned Smith and his plunder:
'What right had he to get so rich
On other people's hunger?"
A prize cartoon depicted Smith
With fat and drooping jowls
Snatching bread from hungry babes,
Indifferent to their howls.

One night, a TV star cried out,
"Forgive me if I stumble,
But I don't think, I kid you not,
That Smith is very humble!"
Growing bolder, he leaped up,

(Silencing the cheers)
"Humility!" he cried to all—
And then collapsed in tears!

The clamor rises all about;
Now hear the politician shout:
'What's Smith done, so rich to be?
Why should Smith have more than thee?
So, down with Smith and all his greed;
I'll protect your right to need!"

Then Tom found to his dismay
That certain businessmen would say,
"The people now should realize
It's time to cut Smith down to size,
For he's betrayed his public trust
(And taken all that bread from us!)"

Well, since the Public does come first,
It could not be denied
That in matters such as this,
The public must decide.
So, SEC became concerned,
And told the press what it had learned:
"It's obvious that he's guilty
—Of what we're not aware—
Though actually and factually
We're sure there's something there!"

And Antitrust now took a hand.
Of course it was appalled
At what it found was going on.
The "bread trust" it was called.

"Smith has too much crust,"
they said. "A deplorable condition
That Robber Barons profit thus
From cutthroat competition!"

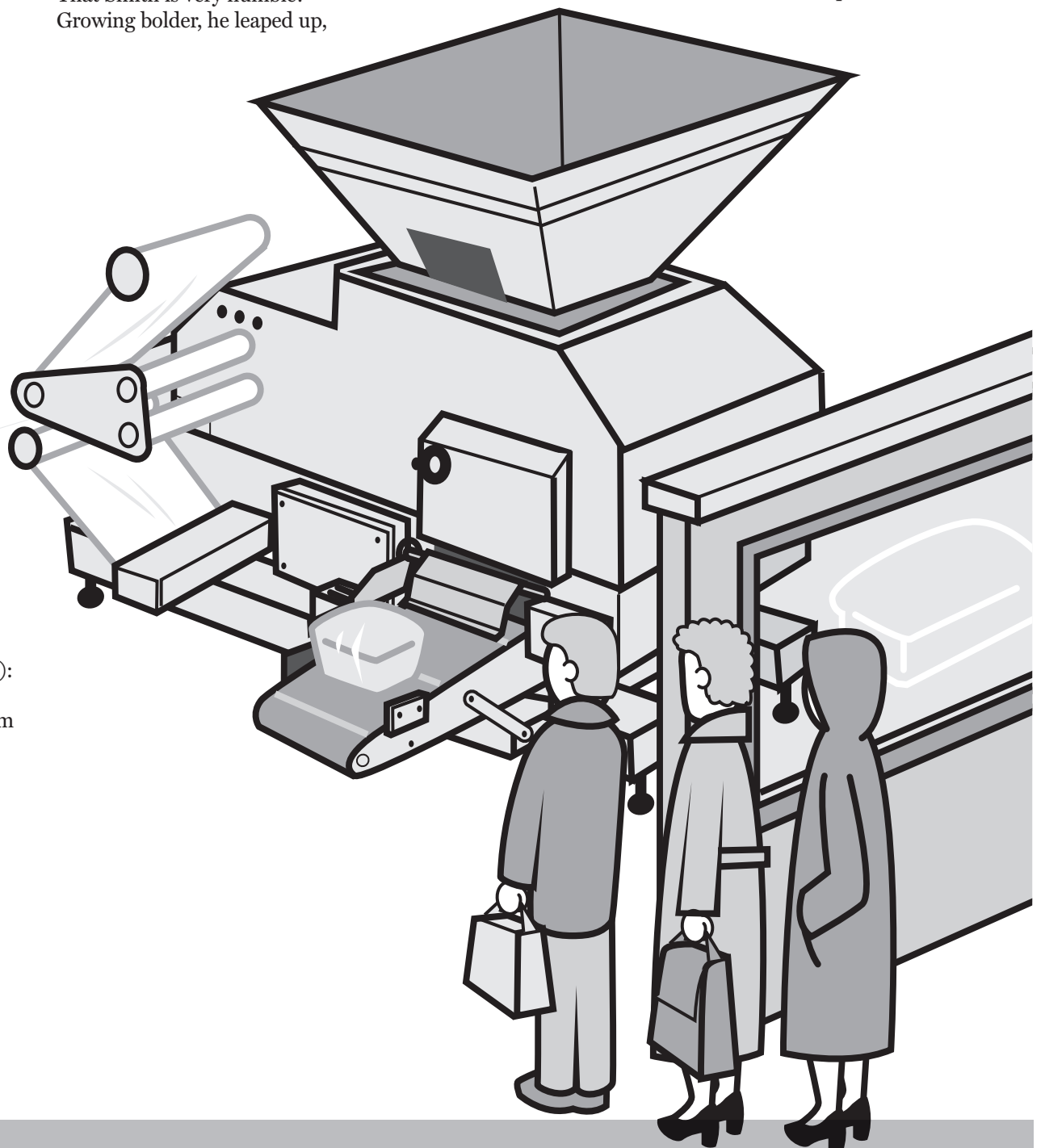

WELL!

This was getting serious!
So Smith felt that he must
Have a friendly interview
With SEC and "Trust."
So, hat in hand, he went to them.
They'd surely been misled;
No rule of law had he defied.
But then their lawyer said:

"The rule of law, in complex times,
Has proved itself deficient.
We much prefer the rule of men.
It's vastly more efficient.

"So, nutshell-wise, the way it is,
The law is what we say it is!

"So, let me state the present rules,"
The lawyer then went on,
"These very simple guidelines
You can rely upon:
You're gouging on your prices
If you charge more than the rest.
But it's unfair competition
If you think you can charge less!
"A second point that we would make,
To help avoid confusion:
Don't try to charge the same amount,
For that would be collusion!"

"You must compete—but not too much.
For if you do, you see,
Then the market would be yours—
And that's monopoly!
Oh, don't dare monopolize!
We'd raise an awful fuss,
For that's the greatest crime of all!
(Unless it's done by us!)"

"I think I understand," said Tom.
"And yet, before I go,
How does one get a job like yours?
I'd really like to know!"

The lawyer rose then with a smile;
"I'm glad you asked," said he.
"I'll tell you how I got my start
And how it came to be."

(His secretaries gathered 'round
As their boss did thus expound.)

*"When I was a lad going off to school,
I was always guided by this golden rule:
Let others take the lead in things, for
heaven's sake,
So if things go wrong-why, then it's their
mistake!"*
(*So if things go wrong-why, then it's their
mistake!*)

*"Following this precept it came to pass
I became the president of my senior class.
Then on to college where my profs extolled
The very same theory from the very same
mold!"*
(*The very same theory from the very same
mold!*)

*"Let others take the chances, and I would
go along.
Then I would let them know where they all
went wrong!
So successful was my system that then
indeed,
I was voted most likely in my class to suc-
ceed!"*

*(He was voted most likely in his class to
succeed!)*

*"Then out into the world I went, along
with all the rest,
Where I put my golden rule to the ulti-
mate test.
I avoided all of commerce at whatever the
cost—
And because I never ventured, then I also
never lost!"*
(*And because he never ventured, then he
also never lost!*)

*"With this unblemished record then, I
quickly caught the eye
Of some influential people 'mongst the
powers on high.*

*And so these many years among the
mighty I have sat,
Having found my niche as a bureaucrat!"*
(*Having found his niche as a bureaucrat*)

*"To be a merchant prince has never been
my goal,
For I'm qualified to play a more impor-
tant role:
Since I've never failed in business, this of
course assures
That I'm qualified beyond dispute to now
run yours!"*
(*That he's qualified beyond dispute to now
run yours!*)

"Thanks; that clears it up," said Tom.

The lawyer said, "I'm glad!
We try to serve the public good.
We're really not so bad!"

"Now, in disposing of this case,
If you wish to know just how,
Go up to the seventh floor;
We're finalizing now!"

So, Tom went to the conference room
Up on the seventh floor.
He raised his hand, about to knock,
He raised it—but no more—
For what he overheard within
Kept him outside the door!
A sentence here, a sentence there—
Every other word—
He couldn't make it out (he hoped),
For this is what he heard:

"Mumble, mumble, let's not fumble!
Mumble, mumble, what's the charge?
Grumble, grumble, he's not humble?
Private greed? Or good of all?"

"Public Interest, Rah! Rah! Rah!
Business, Business, Bah! Bah! Bah!"

"Say, now this now we confess
That now this now is a mess!
Well now, what now do we guess?
Discharge? Which charge would be best?"

"How 'bout 'Greed and Selfishness'?
Oh, wouldn't that be fun?
It's vague enough to trip him up
No matter what he's done!"

"We don't produce or build a thing!
But before we're through,
We allow that now we'll show Smith how
We handle those who do!"

"We serve the public interest;
We make up our own laws;
Oh, golly gee, how selflessly
We serve the public cause!"

"For we're the ones who make the rules
At 'Trust and SEC,
So bye and bye we'll get that guy;
Now, what charge will it be?"

"Price too high? Or price too low?
Now, which charge will we make?
Well, we're not loath to charging both
When public good's at stake!"

"But can we go one better?
How 'bout monopoly?
No muss, no fuss, oh clever us!
Right-O! Let's charge all three!"

"But why stop here? We have one more!
Insider Trading! Number four!
We've not troubled to define
This crime in any way so,
This allows the courts to find
Him guilty 'cause we say so!"

So, that was the indictment.
Smith's trial soon began.
It was a cause célèbre
Which was followed' cross the land.
In his defense Tom only said,
"I'm rich, but all of you are fed!
Is that bargain so unjust
That I should now be punished thus?"

Tom fought it hard all the way.
But it didn't help him win.
The jury took but half an hour
To bring this verdict in:

"Guilty! Guilty! We agree!
He's guilty of this plunder!
He had no right to get so rich
On other people's hunger!"

"Five years in jail!" the judge then said.
"You're lucky it's not worse!
Robber Barons must be taught
Society Comes First!
As flies to wanton boys," he leered,
"Are we to men like these!
They exploit us for their sport!
Exploit us as they please!"

The sentence seemed a bit severe,
But mercy was extended.
In deference to his mother's pleas,
One year was suspended.
And what about the Bread Machine?
Tom Smith's little friend?
Broken up and sold for scrap.
Some win. Some lose. The end.

EPILOGUE

Now, bread is baked by government.
And as might be expected,
Everything is well controlled—
The public well protected.

True, loaves cost ten dollars each.
But our leaders do their best.
The selling price is half a cent.
Taxes pay the rest!



Q&A

Who benefits from legal notices?

You do. Legal notices are required because a government body or corporation wants to take action that can affect individuals and the public at large.

When the government is about to change your life, or your property or assets are about to be taken, public notices in newspapers serve to alert those affected.

Are there different types of legal notices?

Simply put, there are two basic types - Warning Notices and Accountability Notices.

Warning notices inform you when government, or a private party authorized by the government, is about to do something that may affect your life, liberty or pursuit of happiness. Warning notices typically are published more than once over a certain period.

Accountability notices are designed to make sure citizens know details about their government. These notices generally are published one time, and are archived for everyone to see. Accountability is key to efficiency in government.

Are internet-only legal notices sufficient?

No. While the internet is clearly a useful resource, websites should not be used as the sole source of a legal notice.

Websites, whether controlled by a government body or a private firm, are not independent, archived, readily available or independently verified.

Newspaper legal notices fulfill all of those standards.

How much do legal notices cost?

The price for notices in the printed newspaper must include all costs for publishing the ad in print, on the newspaper's website and to www.floridapublicnotices.com.

The public is well-served by notices published in a community newspaper.

VIEW NOTICES ONLINE AT
Legals.BusinessObserverFL.com

To publish your legal notice Email:
legal@businessobserverfl.com

SUBSEQUENT INSERTIONS

--- PUBLIC NOTICES ---

SECOND INSERTION

NOTICE OF PUBLIC SALE

To satisfy the owner's storage lien, PS Retail Sales, LLC will sell at public lien sale on June 22, 2026, the personal property in the below-listed units, which may include but are not limited to: household and personal items, office and other equipment. The public sale of these items will begin at 09:15 AM and continue until all units are sold. The lien sale is to be held at the online auction website, www.storagetreasures.com, where indicated. For online lien sales, bids will be accepted until 2 hours after the time of the sale specified.

PUBLIC STORAGE # 77871, 10437 County Line Rd, Spring Hill, FL 34609, (352) 663-8432

Time: 09:15 AM

Sale to be held at www.storagetreasures.com.

1120 - Hamlin, Aryn; 1140 - Rowles, Lori; 1172 - Harris, DuJuan; 1176 - PAULUS, JOSHUA AARON; 1182 - Daniels, Destiny; 1249 - Cimmino, Giro; 1250 - Magill, Danielle; 2109 - Thomas, Johnnas; 2180 - Tanzola, Andrew; 2200 - Saffold, Lena; 2281 - Penaranda, Christine; 3235 - Stout, Stephanie; 5002 - Alson, Eric; 6000 - Rodriguez, Luis

PUBLIC STORAGE # 22134, 22831 Preakness Blvd, Land O Lakes, FL 34639, (813) 388-9376

Time: 10:00 AM

Sale to be held at www.storagetreasures.com.

01010 - Fernandez, Jose; 02007 - Mc Pherson Sharrock, Andrea; 02013 - carter, kenneth; 02054 - Velazquez, Victor; 02091 - Vera, Desiree; 02115 - Bruce, Linda; 03011 - hernandez, Jessica; 03039 - Little, Brian; 03111 - mccall, Erica; 03146 - Garcia, Luis; 03161 - carter, kenneth; 03204 - Danko, Brittany; 04039 - Tipton, April; 04078 - Cruz, Michelle; 04104 - Telesco, Lisa; 04119 - Kimball, Vanessa; 04188 - Walker, Kanija; 04213 - Richards, Ahmad; 04216 - Long, Jacqueline

PUBLIC STORAGE # 22135, 14900 County Line Rd, Spring Hill, FL 34610, (727) 233-9632

Time: 10:15 AM

Sale to be held at www.storagetreasures.com.

037 - Collins, Maureen; 047 - hill, Tommy; 049 - Stinneli, Lisa; 100 - Roman, Sonia; 150 - Brown, Aaron; 156 - perrault, Katherine; 208 - Express Expediting Solutions Gomez, Jeremy; 290 - Stoddard, Alexander; 296 - Ostrofsky, Debra; 307 - Rivera, Jonathan; 321 - ferris, Clayton; 323 - Kistner, Shona

PUBLIC STORAGE # 25436, 6613 State Road 54, New Port Richey, FL 34653, (727) 493-0578

Time: 10:45 AM

Sale to be held at www.storagetreasures.com.

11019 - Jones, Crystal; 11046 - Crew, Katherine; 11065 - Guzman, Judith Ann; 11093 - Bell, Heather; 11298 - Duke, Angelina; 12069 - Odum, Jessalyn; 12074 - Cunigan, William; 12085 - Torres, Tabitha; 12124 - Delp, Azazel; 12157 - Morales, Jason; 12211 - shaffer, Michaela; 12222 - Laws, Mary Lisa; 12230 - Woods, Shana N; 12256 - Wilson, Jacob; 12263 - Allen, Jeffery; 12268 - Taylor, Jayden; 12289 - bossinger, Lydia; 13011 - Polanco, Omariel; 13017 - JOHN, John di; 13031 - Swan-Christie, Haley; 13065 - Lake, Terriaunna; 13110 - Dennison, April; 13121 - jackson, toby; 13136 - Rodney, Justina; 13160 - Church, Bryson; 13186 - Staley, Andrew; 13206 - Bushard, Sarah; 13310 - Hanlon, Brittinni Miranda; 13331 - Bowman, Clayton; 13339 - Meier, Stephanie; B118 - House, Breanne; B126 - Galloway, Melinda; B140 - Morales, Kelly; B147 - Gonzalez, Maritza; B167 - Vertefeulle, Paulette; B174 - Reale, Michael A; B202 - marino, marianne; B211 - Demarchi, Gordon Edward; B227 - hayes, Hakeem; B242 - Schmidt, Trenton; C158 - Moore, Patrick; C223 - Farrell, Carlene; C236 - Ross, Devina; C255 - Evans, Ronald; C352 - Foust, Jawaun; C401 - Jenkins, Betsy; D219 - Walter, Amy; D330 - Follone, Andrea; P139 - goad, anthony

PUBLIC STORAGE # 25808, 7139 Mitchell Blvd, New Port Richey, FL 34655, (727) 547-3392

Time: 11:30 AM

Sale to be held at www.storagetreasures.com.

1106 - Bullock, Jim; 1204 - Riccardi-Sirico, D'Anna; 1333 - Hyde, Faith; 1409 - shortridge, tonya; 1470 - National Sustainable Sales Kleinops, Percy K; 1495 - Toepfert, Chris; 1501 - Maloney, Ryan; 1820 - Stoddard, Alexander; 1930 - Carzeri, Jenna

PUBLIC STORAGE # 25817, 6647 Embassy Blvd, Port Richey, FL 34668, (727) 491-5429

Time: 11:45 AM

Sale to be held at www.storagetreasures.com.

A0026 - Gardiner, Scott; A0071 - Bresco, Carlos; B0010 - Hill, Jasmyne; D0006 - Galdamez, Chantae; E1131 - Hackett, Evelyn; E1137 - Hassell, Meagan; E1160 - Vercellona, Barbara; E1168 - Whipkey, Heather; E1178 - Adams, Angela; E1196 - Blackman, Stephen; E1204 - Durham, Barry; E1213 - Karakaris, Marie; E1219 - torres, Jahida; E1238 - Gemalsky, Eonna; E2225 - Medina, Joshua; E2290 - Karakaris, Marie; E2358 - Johnson, Melissa

PUBLIC STORAGE # 25856, 4080 Mariner Blvd, Spring Hill, FL 34609, (352) 204-9059

Time: 12:00 PM

Sale to be held at www.storagetreasures.com.

0A102 - amory, Robin; 0A122 - Smith, Britney; 0A134 - Taylor, Danielle; 0A140 - Wiesert, John; 0A154 - Rojas Velasquez, Maria; 0A217 - Hite, Tarsha; 0B008 - Shackett, Sarah; 0B027 - Rader, Brian; 0B050 - Goodrich, Kaitlyn; 0B052 - coyne, Kathleen; 0C015 - valenzano, Angela; 0D034 - POWERS, MICHAEL; 0E020 - Fields, Michael; 0E066 - McBride, Paris; 0E109 - Gill, Denise; 0E140 - Hill, Jakaila; 0E152 - smith, Tammy; 0E239 - poust, bobbiejo

PUBLIC STORAGE # 26595, 2262 US Highway 19, Holiday, FL 34691, (727) 605-0911

Time: 12:15 PM

Sale to be held at www.storagetreasures.com.

021 - Kistler, Brad; 050 - Horn, Janice; 056 - Sanduqa, Dave; 059 - Jones, James; 101 - Kalland, Jordan; 113 - Manavis, Spiros; 140 - Hartnett, Sara; 142 - Ruzicka, Helen; 153 - Woodie, Byron; 241 - Dmonkos, Diana; 294 - Kistler, Brad; 308 - Haywood, Heather; 334 - Morrisson, Aimee; 350 - Rucker, Jacqueline; 405 - Mothers of Minors Inc Clark, Andrea; 481 - Scydick, Terry

PUBLIC STORAGE # 27103, 11435 US Highway 19, Port Richey, FL 34668, (727) 478-2059

Time: 12:30 PM

Sale to be held at www.storagetreasures.com.

1014 - Parlette, Edward; 1027 - Coy, Mitchell; 1060 - Mausshardt, Irene; 1098 - Sarmiento, Jeremiah; 1119 - Surette, Jasmine; 1144 - Cutler, Thomas; 1146 - ely, Alyssa; 1181 - Hicks, Ashley; 1185 - cheverino, Anthony; 2009 - Browning, Kyle; 2049 - Moore, Morgan; 2183 - Bass, Jackson; 2266 - Frith, Joy; 2267 - goodman, dorothy; 2279 - Bass, Sophia; 3030 - Barber, Shawn; 3106 - Mullinax, Natalie; 3131 - Christian, Gordon; 3239 - Caldwell, Andrew J; 3261 - Wilcox, Janae; 3263 - Ryder, Mark; 3267 - Winkelman, Justin; 3290 - Cowsky, Amber; 3293 - Bishop, Brooke; 3294 - Crossman, Greg; 3297 - Gould, Fred S; 3299 - Swenton, Chris; 3340 - rossi, Donald; 3345 - Keen, Delores; 3348 - Vick, Mark

PUBLIC STORAGE # 27678, 9220 Cortez Blvd, Spring Hill, FL 34613, (352) 565-5964

Time: 12:45 PM

Sale to be held at www.storagetreasures.com.

1028 - Haynie, Melanie Marie; 1034 - Gonzalez, Maritza; 1055 - Ashcraft, Nadine; 1059 - Lynn, Katey; 1060 - Miller- Johnson, Denetrius Michele; 1133 - Torres, Stephanie; 1138 - Bowermaster, Cathy; 2060 - Webster, Stephanie; 2115 - Garcia, Russell; 2229 - Ali, Tara; 3059 - Desaulniers, Dee; 3075 - White, Elna; 3110 - Lockett, Tim; 3119 - Lockett, Tim; 3147 - Ortiz, Milton; 3164 - Williams, Freddie; 3183 - Negron, Lizette; 3199 - Lowe, Eric; 3200 - Fonseca, Eric; 3216 - Packler, Dallas; 3218 - Williams, Freddie; 4013 - Frank, Nicki; 4050 - Fortney, Melissa; 4072 - Lockett, Tim; 4077 - Kazee, William

PUBLIC STORAGE # 27886, 6400 Oregon Chickadee Rd, Weeki Wachee, FL 34613, (352) 450-3245

Time: 01:30 PM

Sale to be held at www.storagetreasures.com.

A007 - Crooms, Amber; B009 - Bologna, April; H020 - Burke-Ducharme, Adriana; I015 - Green, Stephen; J014-15 - Salone II, Philip; K007 - Arbuckle, Bart; L009 - Cranford, Jason

PUBLIC STORAGE # 23787, 7294 Broad St, Brooksville, FL 34601, (352) 450-3254

Time: 01:45 PM

Sale to be held at www.storagetreasures.com.

0102 - Cowie, Catherine; 0114 - Bellville, Joseph; 0124 - On Time Courier Service HAYGOOD, BRIAN; 0140 - Cowie, Catherine; 0245 - REDDING, MARQUI DAQUAN; 0307 - Torres, Anjija; 0318 - Williams, Tommy; 0508 - Almonte, Catherine; 0517 - Smith, Naomi; 1000 - Cowie, Catherine; 2020 - Lutz, Michelle; 2040 - Horn, Marshall; 2047 - Cowie, Catherine; 2056 - Cowie, Catherine; 2066 - Havenner, Reanna; A028 - Fuller, Jeff; A039 - Cowie, Catherine; A055 - Patterson, Ashley Eugene; A085 - nipper, Tonia

PUBLIC STORAGE # 23915, 11411 State Rd 52, Hudson, FL 34669, (727) 223-7041

Time: 02:00 PM

Sale to be held at www.storagetreasures.com.

0312 - Lopez, Carmen; 1525 - Poe, James; 1703 - Poe, James; 1709 - Mudry, Avelina; 1710 - Mocaby, Claudia; 1721 - Garcia, Sherie; 2313 - Bammann, Ray; 2520 - lawrence, Timothy; 2552 - Derkowski, Stephen; 2554 - Oram, Tiffany

Public sale terms, rules, and regulations will be made available prior to the sale. All sales are subject to cancellation. We reserve the right to refuse any bid. Payment must be in cash or credit card-no checks. Buyers must secure the units with their own personal locks. To claim tax-exempt status, original RESALE certificates for each space purchased is required. By PS Retail Sales, LLC, 701 Western Avenue, Glendale, CA 91201. (818) 244-8080.

June 5, 12, 2026

26-01284P

PUBLISH YOUR LEGAL NOTICE

We publish all Public sale,
Estate & Court-related notices

- We offer an online payment portal for easy credit card payment
- Service includes us e-filing your affidavit to the Clerk's office on your behalf

Call **941-906-9386**
and select the appropriate County name from the menu option
or email legal@businessobserverfl.com

FLORIDA'S NEWSPAPER FOR THE C-SUITE
Business Observer

--- ESTATE / PUBLIC NOTICES ---

SECOND INSERTION

NOTICE TO CREDITORS
IN THE CIRCUIT COURT OF THE SIXTH JUDICIAL CIRCUIT IN AND FOR PASCO COUNTY, FLORIDA
PROBATE DIVISION
File No. 2026-CP-0578
IN RE: ESTATE OF
FRESA ANNE BARBER, Deceased.

The administration of the estate of FRESA ANNE BARBER, deceased, whose date of death was January 26, 2026, is pending in the Circuit Court for PASCO County, Florida, Probate Division, the street address of which is Attn: Probate, 38053 Live Oak Avenue, Dade City, FL 33523 and the mailing address of which is 38053 Live Oak Avenue, Dade City, FL 33523.

The names and addresses of the personal representative and the personal representative's attorney are set forth below.

All creditors of the decedent and other persons having claims or demands against decedent's estate on whom a copy of this notice is required to be served must file their claims with this court ON OR BEFORE THE LATER OF 3 MONTHS AFTER THE TIME OF THE FIRST PUBLICATION OF THIS NOTICE OR 30 DAYS AFTER THE DATE OF SERVICE OF A COPY OF THIS NOTICE ON THEM.

All other creditors of the decedent and other persons having claims or demands against decedent's estate must file their claims with this court WITHIN 3 MONTHS AFTER THE DATE OF THE FIRST PUBLICATION OF THIS NOTICE.

The personal representative or curator has no duty to discover whether any property held at the time of the decedent's death by the decedent or the decedent's surviving spouse is property to which the Florida Uniform Disposition of Community Property Rights at Death Act as described in ss. 732.216-732.228, Florida Statutes, applies, or may apply, unless a written demand is made by a creditor or a beneficiary as specified under s. 732.221, Florida Statutes. The written demand must be filed with the clerk.

ALL CLAIMS NOT FILED WITHIN THE TIME PERIODS SET FORTH IN FLORIDA STATUTES SECTION 733.702 WILL BE FOREVER BARRED.

NOTWITHSTANDING THE TIME PERIOD SET FORTH ABOVE, ANY CLAIM FILED TWO (2) YEARS OR MORE AFTER THE DECEDENT'S DATE OF DEATH IS BARRED.

The date of first publication of this notice is: June 5, 2026.

Jaimee R. Goode
Personal Representative
7612 Granitville Dr.
Wesley Chapel, FL 33545-4191
Jeffrey S. Goethe
Attorney for Personal Representative
Florida Bar No. 0861420
BARNES WALKER, GOETHE, PERRON, SHEA, JOHNSON & ROBINSON, PLLC
3119 Manatee Avenue West
Bradenton, FL 34205
Telephone: (941) 741-8224
Email: jgoethe@barneswalker.com
June 5, 12, 2026 26-01288P

SECOND INSERTION

NOTICE TO CREDITORS
IN THE CIRCUIT COURT FOR PASCO COUNTY, FLORIDA
PROBATE DIVISION
File No. 2026-CP-734
IN RE: ESTATE OF
BARBARA B. MACDONALD AKA BARBARA BRAYTON MACDONALD
Deceased.

The administration of the estate of BARBARA B. MACDONALD AKA BARBARA BRAYTON MACDONALD, deceased, whose date of death was January 3, 2026, is pending in the Circuit Court for PASCO County, Florida, Probate Division, the address of which is P.O. Drawer 338, New Port Richey, FL 34656-0338. The names and addresses of the personal representative and the personal representative's attorney are set forth below.

All creditors of the decedent and other persons having claims or demands against decedent's estate on whom a copy of this notice is required to be served must file their claims with this court ON OR BEFORE THE LATER OF 3 MONTHS AFTER THE TIME OF THE FIRST PUBLICATION OF THIS NOTICE OR 30 DAYS AFTER THE DATE OF SERVICE OF A COPY OF THIS NOTICE ON THEM.

All other creditors of the decedent and other persons having claims or demands against decedent's estate must file their claims with this court WITHIN 3 MONTHS AFTER THE DATE OF THE FIRST PUBLICATION OF THIS NOTICE.

The personal representative has no duty to discover whether any property

held at the time of the decedent's death by the decedent or the decedent's surviving spouse is property to which the Florida Uniform Disposition of Community Property Rights at Death Act as described in ss. 732.216-732.228, Florida Statutes, applies, or may apply, unless a written demand is made by a creditor as specified under s. 732.221, Florida Statutes. The written demand must be filed with the clerk.

ALL CLAIMS NOT FILED WITHIN THE TIME PERIODS SET FORTH IN FLORIDA STATUTES SECTION 733.702 WILL BE FOREVER BARRED.

NOTWITHSTANDING THE TIME PERIODS SET FORTH ABOVE, ANY CLAIM FILED TWO (2) YEARS OR MORE AFTER THE DECEDENT'S DATE OF DEATH IS BARRED.

The date of first publication of this notice is June 5, 2026.

Personal Representative:
LISA J. MOORE
3602 Hunting Creek Loop
New Port Richey, Florida 34655
Attorney for Personal Representative:
/S/CHRISTINA KANE
CHRISTINA KANE
Attorney
Florida Bar Number: 97970
LYONS LAW GROUP PA
8362 FOREST OAKS BLVD
Spring Hill, FL 34606
Telephone: (352) 515-0101
Fax: (352) 616-0055
E-Mail:
ckane@lyonslawgroup.com
Secondary E-Mail:
cyndi@lyonslawgroup.com
June 5, 12, 2026 26-01282P

SECOND INSERTION

NOTICE TO CREDITORS
IN THE CIRCUIT COURT FOR PASCO COUNTY, FLORIDA
PROBATE DIVISION
File No. 51-2026-CP-000790-WS
IN RE: ESTATE OF
ALAN KOSOW
A/K/A ALAN L. KOSOW
A/K/A ALAN LAWRENCE KOSOW
Deceased.

The administration of the estate of Alan Kosow a/k/a Alan L. Kosow a/k/a Alan Lawrence Kosow, deceased, whose date of death was February 26, 2026, is pending in the Circuit Court for Pasco County, Florida, Probate Division, the address of which is 7530 Little Road. The names and addresses of the personal representative and the personal representative's attorney are set forth below.

All creditors of the decedent and other persons having claims or demands against decedent's estate on whom a copy of this notice is required to be served must file their claims with this court ON OR BEFORE THE LATER OF 3 MONTHS AFTER THE TIME OF THE FIRST PUBLICATION OF THIS NOTICE OR 30 DAYS AFTER THE DATE OF SERVICE OF A COPY OF THIS NOTICE ON THEM.

All other creditors of the decedent and other persons having claims or demands against decedent's estate must file their claims with this court WITHIN 3 MONTHS AFTER THE DATE OF THE FIRST PUBLICATION OF THIS NOTICE.

The personal representative has no duty to discover whether any property

held at the time of the decedent's death by the decedent or the decedent's surviving spouse is property to which the Florida Uniform Disposition of Community Property Rights at Death Act as described in ss. 732.216-732.228, Florida Statutes, applies, or may apply, unless a written demand is made by a creditor as specified under s. 732.221, Florida Statutes. The written demand must be filed with the clerk.

ALL CLAIMS NOT FILED WITHIN THE TIME PERIODS SET FORTH IN FLORIDA STATUTES SECTION 733.702 WILL BE FOREVER BARRED.

NOTWITHSTANDING THE TIME PERIODS SET FORTH ABOVE, ANY CLAIM FILED TWO (2) YEARS OR MORE AFTER THE DECEDENT'S DATE OF DEATH IS BARRED.

The date of first publication of this notice is June 5, 2026.

Personal Representative:
Mallory Kosow
2342 West Bloomingdale Avenue
Apt. 403
Chicago, Illinois 60647
Attorney for Personal Representative:
Ryan A. Doddridge, Esq.
Attorney
Florida Bar Number: 74728
STEARN, WILLIAMS & DODDRIDGE, PA
526 E. Tarpon Avenue
Tarpon Springs, Florida 34689
Telephone: (727) 846-8500
Fax: (727) 848-2814
E-Mail: ryan@flprobatetrustlaw.com
Secondary-E-Mail:
michelle@flprobatetrustlaw.com
June 5, 12, 2026 26-01300P

SECOND INSERTION

NOTICE TO CREDITORS
IN THE CIRCUIT COURT FOR PASCO COUNTY, FLORIDA
PROBATE DIVISION
File No. 26-CP-387
IN RE: ESTATE OF
BARBARA JOYCE OVERLY, Deceased.

The administration of the estate of BARBARA JOYCE OVERLY, deceased, whose date of death was July 29, 2025, is pending in the Circuit Court for Pasco County, Florida, Probate Division, the address of which is 38053 Live Oak Ave, Dade City, FL 33523. The names and addresses of the personal representative and the personal representative's attorney are set forth below.

All creditors of the decedent and other

persons having claims or demands against decedent's estate, on whom a copy of this notice is required to be served, must file their claims with this court ON OR BEFORE THE LATER OF 3 MONTHS AFTER THE TIME OF THE FIRST PUBLICATION OF THIS NOTICE OR 30 DAYS AFTER THE DATE OF SERVICE OF A COPY OF THIS NOTICE ON THEM.

All other creditors of the decedent and other persons having claims or demands against decedent's estate must file their claims with this court WITHIN 3 MONTHS AFTER THE DATE OF THE FIRST PUBLICATION OF THIS NOTICE.

The personal representative has no duty to discover whether any property

held at the time of the decedent's death by the decedent or the decedent's surviving spouse is property to which the Florida Uniform Disposition of Community Property Rights at Death Act as described in ss. 732.216-732.228, applies, or may apply, unless a written demand is made by a creditor as specified under s. 732.221, Florida Statutes.

ALL CLAIMS NOT FILED WITHIN THE TIME PERIODS SET FORTH IN FLORIDA STATUTES SECTION 733.702 WILL BE FOREVER BARRED.

NOTWITHSTANDING THE TIME PERIOD SET FORTH ABOVE, ANY CLAIM FILED TWO (2) YEARS OR MORE AFTER THE DECEDENT'S DATE OF DEATH IS BARRED.

The date of first publication of this notice is: June 5, 2026.

CARMEN JILL HERHOLZ
Personal Representative
1148 Pleasantview Drive
Flushing, MI 48433
Robert D. Hines, Esq.
Attorney for Curator
Florida Bar No. 0413550
Hines Norman Hines, P.L.
1312 W. Fletcher Avenue, Suite B
Tampa, FL 33612
Telephone: 813-265-0100
Email: rhines@hnh-law.com
Secondary Email:
ntservice@hnh-law.com
June 5, 12, 2026 26-01290P

SECOND INSERTION

NOTICE TO CREDITORS
IN THE CIRCUIT COURT FOR PASCO COUNTY, FLORIDA
PROBATE DIVISION
File No. 512026CP000674CPAXWS
Division Probate
IN RE: ESTATE OF
RONALD EARL ENGEL, Deceased.

The administration of the estate of Ronald Earl Engel, deceased, whose date of death was March 17, 2026, is pending in the Circuit Court for Pasco County, Florida, Probate Division, the address of which is West Pasco Judicial Center, 7530 Little Road, New Port Richey, FL 34654. The names and addresses of the personal representative and the personal representative's attorney are set forth below.

All creditors of the decedent and other persons having claims or demands against decedent's estate on whom a copy of this notice is required to be served must file their claims with this court ON OR BEFORE THE LATER OF 3 MONTHS AFTER THE TIME OF THE FIRST PUBLICATION OF THIS NOTICE OR 30 DAYS AFTER THE DATE OF SERVICE OF A COPY OF THIS NOTICE ON THEM.

All other creditors of the decedent and other persons having claims or demands against decedent's estate must file their claims with this court WITHIN 3 MONTHS AFTER THE DATE OF THE FIRST PUBLICATION OF THIS NOTICE.

The personal representative has no

duty to discover whether any property held at the time of the decedent's death by the decedent or the decedent's surviving spouse is property to which the Florida Uniform Disposition of Community Property Rights at Death Act as described in ss. 732.216-732.228, applies, or may apply, unless a written demand is made by a creditor as specified under s. 732.221, Florida Statutes. The written demand must be filed with the clerk.

ALL CLAIMS NOT FILED WITHIN THE TIME PERIODS SET FORTH IN FLORIDA STATUTES SECTION 733.702 WILL BE FOREVER BARRED.

NOTWITHSTANDING THE TIME PERIOD SET FORTH ABOVE, ANY CLAIM FILED TWO (2) YEARS OR MORE AFTER THE DECEDENT'S DATE OF DEATH IS BARRED.

The date of first publication of this notice is June 5, 2026.

Personal Representative:
Samuel James Charles Martin
17708 Coyote Road
Hudson, FL 34667-6029
Attorney for Personal Representative:
John W. Hudzietz II
E-Mail Addresses:
emancinilaw@gmail.com
Florida Bar No. 0844039
Hudzietz & Mancini, P.A.
10028 State Road 52
Hudson, FL 34669
Telephone: (727) 857-9400
June 5, 12, 2026 26-01294P

SECOND INSERTION

NOTICE OF PUBLIC SALE
NOTICE IS HEREBY GIVEN pursuant to Chapter 10, commencing with 21700 of the Business Professionals Code, a sale will be held on June 23, 2026, for Castle Keep Mini Storage at www.StorageTreasures.com bidding to begin on-line June 12, 2026, at 6:00am and ending June 23, 2026, at 12:00pm to satisfy a lien for the follow unit (s). Unit (s) contain general household goods.

Name	Unit
Miles B. Carpentier	F018
Yudislaura Nieves	A034
Walter R. Thompson	B050

June 5, 12, 2026 26-01319P

SECOND INSERTION

Notice Of Public Sale
United of Pasco Self Storage, U-Stor Ridge Rd and U-Stor Zephyrhills
Notice is hereby given that the following storage units are intended to be sold at public auction to satisfy a lien for unpaid rent and charges pursuant to Florida Statutes 83.801-83.809 on June 22, 2026, at the times and locations listed below. Units contain general household goods, tools, fishing tackle, and a Ford food truck (truck is for parts only). All sales are final. Management reserves the right to withdraw any unit from the sale or refuse any offer of bid. Payment by CASH ONLY, unless otherwise arranged.

UNITED OF PASCO SELF STORAGE
Start: June 22, 2026 10:30 AM EST
End: June 29, 2026 3:00 PM EST
Location: 11214 US Hwy 19 North Port Richey, FL 34668
Bidding: All bidding will take place online at bid13.com
B356 Roger Smith
B20 Carrie Binde
B259-B260 Anne Bartlett
R58 Ganesh Umaphathy
U-STOR RIDGE RD
Start: June 22, 2026 10:30 AM EST
End: June 29, 2026 3:00 PM EST
Location: 7215 Ridge Rd., Port Richey, FL 34668
Bidding: All bidding will take place online at bid13.com
C206 Medghyne Calonge
C275 Medghyne Calonge
U-STOR ZEPHYRHILLS
Start: June 22, 2026 10:30 AM EST
End: June 29, 2026 3:00 PM EST
Location: 36654 Pure Water Way, Zephyrhills, FL 33541
Bidding: All bidding will take place online at bid13.com
D7 Regina Sones
D42AC Micaela Hernandez
C76 Martin Asua
June 5, 12, 2026 26-01306P

Email your Legal Notice
legal@businessobserverfl.com
Deadline Wednesday at noon • Friday Publication

SARASOTA • MANATEE • HILLSBOROUGH • PASCO
PINELLAS • POLK • LEE • COLLIER • CHARLOTTE

Business Observer

--- ACTIONS / SALES / ESTATE / PUBLIC NOTICES ---

FOURTH INSERTION

NOTICE OF SHERIFF'S SALE

Notice is hereby given that pursuant to a Writ of Execution issued in the Sixth Judicial Circuit Court, of Pasco County, Florida on the 14th day of July, 2025, in the cause wherein Steven Ryan Schmidt, Newlyn Zimmerman, are Plaintiff's, and Smith and Associates Real Estate LLC, Victoria Vickie Truex, John Done, are Defendant's, being case number 2022CA003266CAAXWS in said Court.

I, Chris Nacco, as Sheriff of Pasco County, Florida, have levied upon all the right, title, and interest of the defendant, William Earl Starkey, in and to the following described property, to wit:

2023 Hyundai Elantra
VIN# KMHLW4AK2PU010269
I shall offer this property for sale "AS IS" on June 24, 2026, @ 10:00am or as soon thereafter as possible, at Crockett's Towing 1360 I US-4 I, Spring Hill, FL 34610 in the County of Pasco, State of Florida. I will offer for sale all of the Defendant's right, title, and interest in aforesaid property at public outcry and will sell the same, subject to all prior liens, encumbrances, and judgments, if any, to the highest and best bidder or bidders for CASH, the proceeds to be applied as far as may be to the payment of costs and the satisfaction of the above-described execution.
Law Offices of Sprechman & Fisher PA
C/O Steve Sprechman, Esq
2775 Sunny Isles Boulevard, Suite 100
Miami, FL 33160
CHRIS NOCCO, as Sheriff
Pasco County, Florida
By: Sgt. Matthew Adamo Deputy Sheriff
May 22, 29; June 5, 12, 2026

26-01208P

FOURTH INSERTION

VIDA'S WAY COMMUNITY DEVELOPMENT DISTRICT
NOTICE OF THE DISTRICT'S INTENT TO USE THE UNIFORM METHOD OF COLLECTION OF NON-AD VALOREM SPECIAL ASSESSMENTS

Notice is hereby given that the Vida's Way Community Development District (the "District") intends to use the uniform method of collecting non-ad valorem special assessments to be levied by the District pursuant to Section 197.3632, Florida Statutes. The Board of Supervisors of the District will conduct a public hearing at 11:00 a.m. on June 16, 2026, at the Hampton Inn & Suites by Hilton - Tampa/Wesley Chapel, 2740 Cypress Ridge Blvd., Wesley Chapel, Florida 33544.

The purpose of the public hearing is to consider the adoption of a resolution authorizing the District to use the uniform method of collecting non-ad valorem special assessments (the "Uniform Method") to be levied by the District on properties located on land included in, or to be added to, the District.

The District may levy non-ad valorem special assessments for the purpose of financing, acquiring, maintaining and/or operating community development facilities, services, and improvements within and without the boundaries of the District, to consist of, among other things, stormwater management system, onsite and off-site public roadway improvements, water, wastewater, and reclaim utilities, hard-scape/landscape/irrigation improvements, streetlighting and undergrounding of electrical utilities, and/or any other lawful improvements or services of the District.

Owners of the properties to be assessed and other interested parties may appear at the public hearing and be heard regarding the use of the Uniform Method. This hearing is open to the public and will be conducted in accordance with the provisions of Florida law. The public hearing may be continued to a date, time, and location to be specified on the record at the hearing. There may be occasions when Supervisors or District Staff may participate by speaker telephone.

Pursuant to provisions of the Americans with Disabilities Act, any person requiring special accommodations to participate in the hearing and/or meeting is asked to contact the District Manager's office at 2300 Glades Road, Suite 410W, Boca Raton, Florida 33431. (561) 571-0010, at least forty-eight (48) hours before the hearing and/or meeting. If you are hearing or speech impaired, please contact the Florida Relay Service at 1-800-955-8771 who can aid you in contacting the District Manager's Office.

Each person who decides to appeal any decision made by the Board with respect to any matter considered at the hearing is advised that person will need a record of the proceedings and that accordingly, the person may need to ensure that a verbatim record of the proceedings is made, including the testimony and evidence upon which such appeal is to be based.

Kristen Suit
District Manager
May 22, 29; June 5, 12, 2026

26-01187P

SECOND INSERTION

NOTICE OF ACTION
IN THE CIRCUIT COURT OF THE SIXTH JUDICIAL CIRCUIT IN AND FOR PASCO COUNTY, FLORIDA
CASE NO.: 2025CA001050
NEWREZ LLC D/B/A SHELL-POINT MORTGAGE SERVICING, Plaintiff, v.
UNKNOWN PERSONAL REPRESENTATIVE OF THE ESTATE OF LARRY D. COX A/K/A LARRY DEAN COX, et al., Defendants.

TO: Angela Maria Cox Benjamin
1621 Battleground Avenue
Greensboro, NC 27408
Angela Maria Cox Benjamin
8543 Benbow Merrill Rd.
Oak Ridge, NC 27310
Angela Maria Cox Benjamin
21312 114th PL
Live Oak, FL 32060
Angela Maria Cox Benjamin
1405 Duval St. NE, Lot 18
Live Oak, FL 32064
Angela Maria Cox Benjamin
1200 Canada Rd.
Greensboro, NC 27407
Angela Maria Cox Benjamin
4255 Pine Cone Ter.
Northport, FL 34286
Unknown Personal Representative of the Estate of Larry D. Cox a/k/a Larry Dean Cox

Last known address: Unknown
Unknown Heirs, Beneficiaries and Devises of the Estate of Larry D. Cox a/k/a Larry Dean Cox

Last known address: Unknown
YOU ARE HEREBY NOTIFIED that an action to foreclose a mortgage on the following described property in Pasco County, Florida:

Lot 120, LAKESHORE RANCH PHASES 2 & 3, according to the Plat thereof recorded in Plat Book 63, Page 51, of the Public

Records of Pasco County, Florida.

has been filed against you and you are required to serve a copy of your written defenses, if any, on Anthony R. Smith, Esquire, the Plaintiff's attorney, whose address is Tiffany & Bosco, P.A., 1201 S. Orlando Ave, Suite 430, Winter Park, FL 32789, on or before thirty (30) days from the date of first publication of this Notice, and file the original with the Clerk of this Court either before service on the Plaintiff's attorney or immediately thereafter; or a default will be entered against you for the relief demanded in the complaint. DUE ON OR BEFORE JULY 6, 2026

If you are a person with a disability who needs any accommodation in order to participate in this proceeding, you are entitled, at no cost to you, to the provision of certain assistance. Please contact either the Pasco County Customer Service Center, 8731 Citizens Drive, New Port Richey, FL 34654, (727) 847-2411 (V) of the Pasco County Risk Management Office, 7536 State Street, New Port Richey, FL 34654, (727) 847-8028 (V) at least 7 days before your scheduled court appearance, or immediately upon receiving this notification if the time before the scheduled appearance is less than 7 days; if you are hearing or voice impaired, call 711.

IN WITNESS WHEREOF, I have hereunto set my hand and affixed the official seal of said Court at Pasco County, Florida, this June 3, 2026

Nikki Alvarez-Sowles
Pasco County Clerk & Comptroller
Deputy Clerk: Shakira Ramirez Pagen
Anthony R. Smith, Esquire,
the Plaintiff's attorney,
Tiffany & Bosco, P.A.,
1201 S. Orlando Ave, Suite 430,
Winter Park, FL 32789
June 5, 12, 2026

26-01317P

SECOND INSERTION

NOTICE TO CREDITORS
(Summary Administration)
IN THE CIRCUIT COURT FOR PASCO COUNTY, FLORIDA
PROBATE DIVISION
File No. 51-2026-CP-0731-WS
IN RE: ESTATE OF
WILLIAM LAWRENCE LOWRIE
Deceased.

TO ALL PERSONS HAVING CLAIMS OR DEMANDS AGAINST THE ABOVE ESTATE:

You are hereby notified that an Order of Summary Administration has been entered in the estate of WILLIAM LAWRENCE LOWRIE, deceased, File Number 51-2026-CP-0731-WS, by the Circuit Court for PASCO County, Florida, Probate Division, the address of which is 7530 Little Road, New Port Richey, FL 34654; that the decedent's date of death was December 29, 2025; that the total value of the estate is approximately \$13,480.00 and that the names and addresses of those to whom it has been assigned by such order are:

Name Address
Barbara Jane Lowrie
14047 Shoal Dr.
Hudson, FL 34667

ALL INTERESTED PERSONS ARE NOTIFIED THAT:

All creditors of the estate of the decedent and persons having claims or demands against the estate of the decedent other than those for whom provision for full payment was made in the Order of Summary Administration must file their claims with this court WITHIN THE TIME PERIODS SET FORTH IN FLORIDA STATUTES

SECOND INSERTION

NOTICE OF ACTION
IN THE CIRCUIT COURT OF THE SIXTH JUDICIAL CIRCUIT OF FLORIDA IN AND FOR PASCO COUNTY

CASE NO. 2026CA000982CAAXES
LAKEVIEW LOAN SERVICING, LLC, Plaintiff, vs.

CANDICE SEWARD, et al., Defendant.

TO: ANY AND ALL UNKNOWN PARTIES CLAIMING BY, THROUGH, UNDER, AND AGAINST ESTATE OF PAULA N MARTANIUK A/K/A PAULA MARTANIUK, WHETHER SAID UNKNOWN PARTIES MAY CLAIM AN INTEREST AS SPOUSES, HEIRS, DEVISEES, GRANTEES, OR OTHER CLAIMANTS

YOU ARE HEREBY NOTIFIED that an action for Foreclosure of Mortgage on the following described property: LOT 6, WILLOW BEND TRACT MF-2, ACCORDING TO THE MAP OR PLAT THEREOF, AS RECORDED IN PLAT BOOK 35, PAGE(S) 102 THROUGH 106, INCLUSIVE, OF THE PUBLIC RECORDS OF PASCO COUNTY, FLORIDA.

has been filed against you and you are required to file a copy of your written defenses, if any, to it on McCalla Raymer Leibert Pierce, LLP, Jamie Juster, Attorney for Plaintiff, whose address is 225 East Robinson Street, Suite 155, Orlando, FL 32801 and file the original with the Clerk of the above-styled Court on or before July 6, 2026 or 30 days from the first publication, otherwise a Judgment may be entered against you for the relief demanded in

SECOND INSERTION

NOTICE TO CREDITORS
(Summary Administration)
IN THE CIRCUIT COURT FOR PASCO COUNTY, FLORIDA
PROBATE DIVISION
File No.: 26-CP-000762-WS
Division: J

IN RE: The Estate of DOLORES JEAN EVERETTE, a/k/a DOLORES J. EVERETTE, a/k/a DOLORES EVERETTE, Deceased.

TO ALL PERSONS HAVING CLAIMS OR DEMANDS AGAINST THE ABOVE ESTATE:

You are hereby notified that an Order of Summary Administration has been entered in the estate of Dolores Jean Everette, a/k/a Dolores J. Everette, deceased, File Number 26-CP-000762-WS, Division J, by the Circuit Court for Pasco County, Florida, Probate Division, the address of which is 7530 Little Road, New Port Richey, Florida 34654; that the decedent's date of death was November 2, 2025; that the total value of the estate is \$58,834.67 and that the names and addresses of those to whom it has been assigned by such order are:

Name Address
Jeffrey A. Sommers, as Trustee of THE DOLORES J. EVERETTE TRUST,
9548 Sunshine Boulevard
New Port Richey, FL 34654

ALL INTERESTED PERSONS ARE NOTIFIED THAT:

All creditors of the estate of the decedent and persons having claims or demands against the estate of the decedent other than those for whom provision for full payment was made in the Order of Summary Administration must file their claims with this court

SECTION 733.702. ALL CLAIMS AND DEMANDS NOT SO FILED WILL BE FOREVER BARRED. NOTWITHSTANDING ANY OTHER APPLICABLE TIME PERIOD, ANY CLAIM FILED TWO (2) YEARS OR MORE AFTER THE DECEDENT'S DATE OF DEATH IS BARRED.

The personal representative has no duty to discover whether any property held at the time of the decedent's death by the decedent or the decedent's surviving spouse is property to which the Florida Uniform Disposition of Community Property Rights at Death Act as described in sections 732.216-732.288 Florida Statutes, applies, or may apply, unless a written demand is made by a creditor as specified under section 732.221, Florida Statutes. The written demand must be filed with the clerk.

The date of first publication of this Notice is June 5, 2026.

Person Giving Notice:
Barbara Jane Lowrie
14047 Shoal Dr.
Hudson, Florida 34667
Attorney for Person Giving Notice

DONALD R. PEYTON
Attorney
Florida Bar Number: 516619
7317 Little Road
New Port Richey, FL 34654
Telephone: (727) 848-5997
Fax: (727) 848-4072
E-Mail: peytonlaw@yahoo.com
Secondary E-Mail:
peytonlaw2@gmail.com
June 5, 12, 2026

26-01289P

SECOND INSERTION

the Complaint.

If you are a person with a disability who needs any accommodation in order to participate in this proceeding, you are entitled, at no cost to you, to the provision of certain assistance. Please contact the Public Information Dept., Pasco County Government Center, 7530 Little Rd., New Port Richey, FL 34654; (727) 847-8110 (V) in New Port Richey; (352) 521-4274, ext 8110 (V) in Dade City, at least 7 days before your scheduled court appearance, or immediately upon receiving this notification if the time before the scheduled appearance is less than 7 days; if you are hearing impaired call 711. The court does not provide transportation and cannot accommodate for this service. Persons with disabilities needing transportation to court should contact their local public transportation providers for information regarding transportation services.

WITNESS my hand and seal of this Court this 28 day of May, 2026.

NIKKI ALVAREZ-SOWLES, ESQ.
CLERK OF COURT OF PASCO COUNTY
As Clerk of the Court
(SEAL) BY: Shakira Ramirez Pagan
2026-CA-982ES
Deputy Clerk

MCCALLA RAYMER LEIBERT
PIERCE, LLP
225 East Robinson Street,
Suite 155,
Orlando, FL 32801
Phone: (407) 674-1850
Fax: (321) 248-0420
Email:
AccountsPayables@mccalla.com
25-15467FL
June 5, 12, 2026

26-01281P

THIRD INSERTION

NOTICE OF ACTION
IN THE CIRCUIT COURT OF THE SIXTH JUDICIAL CIRCUIT IN AND FOR PASCO COUNTY

CASE NO.
2025DP000093DPAXWS

In the Interest of:
A.C.S. DOB: 7/28/2025,
MINOR CHILD

TO: Christopher Young, address unknown

YOU ARE HEREBY NOTIFIED that the State of Florida, Department of Children and Families, has filed a Petition to terminate your parental rights and permanently commit the following child for adoption: A.C.S. born on 7/28/2025. You are hereby commanded to appear on August 4, 2026 at 2:00 PM before the Honorable Lauralee Westine at the Pasco Courthouse, 7530 Little Road New Port Richey, FL 34654, for an ADVISORY HEARING.

FAILURE TO PERSONALLY APPEAR AT THIS ADVISORY HEARING CONSTITUTES CONSENT TO THE TERMINATION OF PARENTAL RIGHTS OF THIS CHILD. IF YOU FAIL TO APPEAR ON THE DATE AND TIME SPECIFIED, YOU MAY LOSE ALL LEGAL RIGHTS AS A PARENT TO THE CHILD NAMED IN

THIS NOTICE.

If you are a person with a disability who needs any accommodation in order to participate in this proceeding, you are entitled, at no cost to you, to the provision of certain assistance. Please contact the Public Information Dept., Pasco County Government Center, 7530 Little Rd., New Port Richey, FL 34654; (727) 847-8110 (V) for proceedings in New Port Richey; (352) 521-4274, ext. 8110 (V) for proceedings in Dade City at least 7 days before your scheduled court appearance, or immediately upon receiving this notification if the time before the scheduled appearance is less than 7 days; if you are hearing or voice impaired, call 711.

WITNESS, my hand and the seal of this Court on 27th day of May, 2026.

Office Of
Nikki Alvarez-Sowles, Esq.
CLERK AND COMPTROLLER (SEAL)
By: Karen S. Papadopoulos
Deputy Clerk

/s/ Jennifer Smith, Esq.
Assistant State Attorney
FL Bar No: 0085418
May 29; June 5, 12, 19, 2026

26-01276P

THIRD INSERTION

Linda Faye
P.O. Box 947
Kingman AZ 86402
928-897-4434
lrichardson95@gmail.com

SUMMONS
SUPERIOR COURT OF ARIZONA
MOHAVE COUNTY
Case Number:
DO2026-00194

Linda Faye Richardson
Petitioner
AND
Jacob Adam Richardson
Respondent
FROM THE STATE OF ARIZONA TO:
Jacob Adam Richardson

1. A lawsuit has been filed against you. A copy of the lawsuit and other court papers are served on you with this Summons.

2. If you do not want a judgment or order taken against you without your input, you must file an "Answer" or a "Response" in writing with the Court, and pay the filing fee. If you do not file an "Answer" or "Response" the other party may be given the relief requested in his or her Petition or Complaint. To file your "Answer" or "Response" take, or send, the "Answer" or "Response" to the Office of the Clerk of the Superior Court, 415 East Spring Street, Kingman, AZ 86401 (P.O. Box 7000, Kingman, AZ 86402-7000) or the Office of the Clerk of the Superior Court, 2225 Trane Road, Bullhead City, AZ 86442, or Office of the Clerk of the Superior Court, 2001 College Drive, Lake Havasu City, AZ 86404. Mail a copy of your "Answer" or "Response" to the oth-

er party at the address listed on the top of this Summons.

3. If this Summons and the other court papers were served on you by a registered process server or the Sheriff, within the State of Arizona, your "Response" or "Answer" must be filed within TWENTY (20) CALENDAR DAYS, starting the day after you were served. If this "Summons" and other court papers were served on you by a registered process server or the Sheriff outside the State of Arizona, your "Response" must be filed within THIRTY (30) CALENDAR DAYS, starting the day after you were served. Service by a registered process server or the Sheriff is complete when made. Service by Publication is complete (30) days after the date of the first publication.

4. You can get a copy of the court papers filed in this case from the Petitioner at the address at the top of this paper, or from the Clerk of the Superior Court at the address listed in Paragraph 2 above.

5. Requests for reasonable accommodation for persons with disabilities must be made to the office of the judge or commissioner assigned to the case, at least (5) five days before your scheduled court date.

SIGNED AND SEALED this date:
February 26, 2026

CHRISTINA SPURLOCK,
Clerk of the Superior Court

By: /s/
Deputy Clerk

May 29; June 5, 12, 19, 2026

26-01254P

SECOND INSERTION

NOTICE OF ACTION
IN THE CIRCUIT COURT OF THE 6TH JUDICIAL CIRCUIT, IN AND FOR PASCO COUNTY, FLORIDA
CIVIL DIVISION

CASE NO.:
2026CA000692CAAXWS

VILLAGE CAPITAL & INVESTMENT LLC,
Plaintiff, vs.

BRENT M BENNETT AND REYNA ASHLEY BATES A/K/A REYNA ASHLEY AKA REYNA ASHELY, et al.,
Defendants.

TO:
BRENT M BENNETT
8337 SHALLOW CREEK CT, NEW PORT RICHEY 34653
UNKNOWN SPOUSE OF BRENT M. BENNETT AKA BRENT BENNETT
8337 SHALLOW CREEK CT, NEW PORT RICHEY 34653

YOU ARE NOTIFIED that an action for Foreclosure of Mortgage on the following described property:

TRACT 573 OF THE UNRECORDED PLAT OF PARKWOOD ACRES SUBDIVISION, UNIT FOUR, BEING FURTHER DESCRIBED AS FOLLOWS:

COMMENCING AT THE NORTHEAST CORNER OF SECTION 1, TOWNSHIP 25 SOUTH, RANGE 16 EAST, PASCO COUNTY, FLORIDA, GO THENCE NORTH 89 DEGREES 17' 10" WEST ALONG THE NORTH LINE OF SAID SECTION 1, A DISTANCE OF 2,150.0 FEET TO THE POINT OF BEGINNING, CONTINUE THENCE NORTH 89 DEGREES 17' 10" WEST A DISTANCE OF 100.0 FEET, THENCE SOUTH 00 DEGREES 51' 07" WEST, A DISTANCE OF 250.0 FEET, THENCE SOUTH 89 DEGREES 17' 10" EAST, A DISTANCE OF 100.0 FEET, THENCE NORTH 00 DEGREES 51' 07" EAST A DISTANCE OF 250.0 FEET TO THE POINT OF BEGIN-

NING, EXCEPTING THEREFROM THE SOUTHERLY AND NORTHERLY 25.0 FEET THEREOF TO BE USED FOR ROAD RIGHT-OF-WAY PURPOSES.

has been filed against you and you are required to serve a copy of your written defenses, if any, to it, on De Cubas & Lewis, P.A., Attorney for Plaintiff, whose address is PO BOX 5026, FORT LAUDERDALE, FL 33310 on or before JULY 6, 2026, a date at least thirty (30) days after the first publication of this Notice in the (Please publish in BUSINESS OBSERVER) and file the original with the Clerk of this Court either before service on Plaintiff's attorney or immediately thereafter; otherwise a default will be entered against you for the relief demanded in the complaint.

If you are a person with a disability who needs an accommodation in order to participate in this proceeding, you are entitled, at no cost to you, to the provision of certain assistance. Please contact: Public Information Dept., Pasco County Government Center, 7530 Little Rd., New Port Richey, FL 34654; Phone: 727.847.8110 (voice) in New Port Richey, 352.521.4274, ext 8110 (voice) in Dade City, Or 711 for the hearing impaired. Contact should be initiated at least seven days before the scheduled court appearance, or immediately upon receiving this notification if the time before the scheduled appearance is less than seven days. The court does not provide transportation and cannot accommodate such requests. Persons with disabilities needing transportation to court should contact their local public transportation providers for information regarding transportation services.

WITNESS my hand and the seal of this Court this 18 day of MAY, 2026.

(SEAL) Nikki Alvarez-Sowles
Pasco County Clerk & Comptroller
Deputy Clerk: Julian Garcia

De Cubas & Lewis, P.A.,
Attorney for Plaintiff,
PO BOX 5026,
FORT LAUDERDALE, FL 33310
25-05382
June 5, 12, 2026

26-01292P

PUBLISH YOUR LEGAL NOTICE
Call 941-906-9386
and select the appropriate County name from the menu.
or email
legal@businessobserverfl.com



--- ACTIONS / SALES ---

SECOND INSERTION

NOTICE OF ACTION
IN THE CIRCUIT COURT OF THE SIXTH JUDICIAL CIRCUIT IN AND FOR PASCO COUNTY, FLORIDA
CASE NO.: 2026-CA-000643

M&T BANK,
Plaintiff, vs.
ROBERT NIEHAUS JR, et al.,
Defendants.
TO:
Robert Niehaus Jr
4816 Mirage Avenue
Holiday, FL 34690
Robert Niehaus Jr
827 Village Way
Palm Harbor, FL 34683
Unknown Spouse of Robert Niehaus Jr
4816 Mirage Avenue
Holiday, FL 34690
Unknown Spouse of Robert Niehaus Jr
827 Village Way
Palm Harbor, FL 34683

YOU ARE HEREBY NOTIFIED that an action to foreclose a mortgage on the following described property in Pasco County, Florida:

Lot 539, of Crest Ridge Gardens - Unit Six, as per plat thereof, as recorded in Plat Book 8, Page 113, of the Public Records of Pasco County, Florida.

has been filed against you and you are required to serve a copy of your written defenses, if any, on Anthony R. Smith, Esquire, the Plaintiff's attorney, whose address is Tiffany & Bosco, P.A., 1201 S. Orlando Ave, Suite 430, Winter Park, FL 32789, on or before thirty (30) days

from the date of first publication of this Notice, and file the original with the Clerk of this Court either before service on the Plaintiff's attorney or immediately thereafter; or a default will be entered against you for the relief demanded in the complaint. DUE ON OR BEFORE JULY 6, 2026

If you are a person with a disability who needs an accommodation in order to participate in this proceeding, you are entitled, at no cost to you, to the provision of certain assistance. Please contact: Public Information Dept., Pasco County Government Center, 7530 Little Rd., New Port Richey, FL 34654; Phone: 727.847.8110 (voice) in New Port Richey, 352.521.4274, ext 8110 (voice) in Dade City, Or 711 for the hearing impaired. Contact should be initiated at least seven days before the scheduled court appearance, or immediately upon receiving this notification if the time before the scheduled appearance is less than seven days. The court does not provide transportation and cannot accommodate such requests. Persons with disabilities needing transportation to court should contact their local public transportation providers for information regarding transportation services.

WITNESS my hand and the seal of this Court this June 2, 2026.

(SEAL) Nikki Alvarez-Sowles
Pasco County Clerk & Comptroller
Deputy Clerk: Shakira Ramirez Pagan
June 5, 12, 2026 26-01311P

SECOND INSERTION

NOTICE OF ACTION
IN THE CIRCUIT COURT OF THE SIXTH JUDICIAL CIRCUIT OF FLORIDA IN AND FOR PASCO COUNTY

GENERAL JURISDICTION DIVISION
CASE NO. 2025CA004118CAAXWS
FREEDOM MORTGAGE CORPORATION,
Plaintiff, vs.
MICHAEL LEE ADIX, et al.,
Defendant.

To: CORINNE ADIX
17031 KETTLE LANE APT 409
LAND O LAKES, FL 34638
NOTICE OF ACTION
UNKNOWN TENANT IN POSSESSION 2
2902 PUNTA PALMA COURT
HOLIDAY, FL 34691

LAST KNOWN ADDRESS STATED, CURRENT RESIDENCE UNKNOWN
YOU ARE HEREBY NOTIFIED that an action for Foreclosure of Mortgage on the following described property: LOT 10, KEY VISTA PHASE 1, ACCORDING TO THE PLAT THEREOF AS RECORDED IN PLAT BOOK 39, PAGES 102 TO 112, INCLUSIVE, OF THE PUBLIC RECORDS OF PASCO COUNTY, FLORIDA.

has been filed against you and you are required to file a copy of your written defenses, if any, to it on Curtis Wilson, Esq., McCalla Raymer Leibert Pierce, LLP, 225 East Robinson Street, Suite 155, Orlando, FL 32801 and file the original with the Clerk of the above-styled Court on or before JULY 6, 2026 or 30 days from the first publication,

otherwise a Judgment may be entered against you for the relief demanded in the Complaint.

If you are a person with a disability who needs an accommodation in order to participate in this proceeding, you are entitled, at no cost to you, to the provision of certain assistance. Please contact the Public Information Dept., Pasco County Government Center, 7530 Little Rd., New Port Richey, FL 34654; (727) 847-8110 (V) in New Port Richey; (352) 521-4274, ext 8110 (V) in Dade City, at least 7 days before your scheduled court appearance, or immediately upon receiving this notification if the time before the scheduled appearance is less than 7 days; if you are hearing impaired call 711. The court does not provide transportation and cannot accommodate for this service. Persons with disabilities needing transportation to court should contact their local public transportation providers for information regarding transportation services.

WITNESS my hand and seal of this Court on June 3, 2026, 2026.

NIKKI ALVAREZ-SOWLES, ESQ.,
CLERK OF COURT OF
PASCO COUNTY
As Clerk of the Court
(SEAL) BY: Shakira Ramirez Pagan
Deputy Clerk

MCCALLA RAYMER LEIBERT
PIERCE, LLP
225 East Robinson Street, Suite 155,
Orlando, FL 32801
Phone: (407) 674-1850
Fax: (321) 248-0420
Email:AccountsPayables@mccalla.com
25-14647FL
June 5, 12, 2026 26-01318P

SECOND INSERTION

NOTICE OF ACTION - CONSTRUCTIVE SERVICE
IN THE CIRCUIT COURT OF THE SIXTH JUDICIAL CIRCUIT IN AND FOR PASCO COUNTY, FLORIDA

GENERAL JURISDICTION DIVISION

Case No. 512026CA000547CAAXES
Freedom Mortgage Corporation
Plaintiff, vs.
Karen Heilbron Rada; Mauricio Diaz Rivas; United States of America on behalf of the Secretary of Housing and Urban Development; Ashton Oaks Homeowners' Association, Inc.
Defendants.
TO: Karen Heilbron Rada and Mauricio Diaz Rivas
Last Known Address: 4049 Pacente Loop, Wesley Chapel, FL 33543

YOU ARE HEREBY NOTIFIED that an action to foreclose a mortgage on the following property in Pasco County, Florida:

LOT 203, ASHTON OAKS SUBDIVISION, PHASE 4, ACCORDING TO THE MAP OR PLAT THEREOF, AS RECORDED IN PLAT BOOK 67, PAGE(S) 84 THROUGH 92, INCLUSIVE, OF THE PUBLIC RECORDS OF PASCO COUNTY, FLORIDA.

has been filed against you and you are required to serve a copy of your written defenses, if any, to it on Julie York, Esquire, Brock & Scott, PLLC., the Plaintiff's attorney, whose address is 4919 Memorial Hwy, Suite 135, Tampa, FL 33634, within thirty (30) days of the first date of publication on or before

July 6, 2026, and file the original with the Clerk of this Court either before service on the Plaintiff's attorney or immediately thereafter; otherwise a default will be entered against you for the relief demanded in the complaint or petition.

THIS NOTICE SHALL BE PUBLISHED ONCE A WEEK FOR TWO (2) CONSECUTIVE WEEKS

If you are a person with a disability who needs an accommodation in order to participate in this proceeding, you are entitled, at no cost to you, to the provision of certain assistance. Please contact the Public Information Dept., Pasco County Government Center, 7530 Little Rd., New Port Richey, FL 34654; (727) 847-8110 (V) in New Port Richey; (352) 521-4274, ext 8110 (V) in Dade City, at least 7 days before your scheduled court appearance, or immediately upon receiving this notification if the time before the scheduled appearance is less than 7 days; if you are hearing impaired call 711. The court does not provide transportation and cannot accommodate for this service. Persons with disabilities needing transportation to court should contact their local public transportation providers for information regarding transportation services.

DATED on June 2, 2026.

Nikki Alvarez-Sowles
As Clerk of the Court
(SEAL) By /s/ Shakira Ramirez Pagan
As Deputy Clerk

Brock & Scott, PLLC.,
the Plaintiff's Attorney
4919 Memorial Hwy, Suite 135,
Tampa, FL 33634
File # 23-F02250
June 5, 12, 2026 26-01309P

NOTICE OF ACTION
IN THE CIRCUIT COURT OF THE SIXTH JUDICIAL CIRCUIT OF FLORIDA IN AND FOR PASCO COUNTY

GENERAL JURISDICTION DIVISION
CASE NO. 2026-CA-000347
WILMINGTON SAVINGS FUND SOCIETY, FSB, NOT IN ITS INDIVIDUAL CAPACITY, BUT SOLELY AS TRUSTEE FOR RESIDENTIAL MORTGAGE AGGREGATION TRUST,
Plaintiff, vs.
MAGA INVESTMENTS OF TAMPA FLORIDA LLC, MARK ROSENBERG, KEN JACK, LOANHIVE RE LLC, AC TECH LLC, AVSHALOM HADAD, UNKNOWN TENANT IN POSSESSION 1, and UNKNOWN TENANT IN POSSESSION 2,
Defendant.

To: MAGA INVESTMENTS OF TAMPA FLORIDA LLC
c/o Ken Jack as Registered Agent
1646 West Snow Avenue
Tampa, Florida 33606
KEN JACK
5018 East 122nd Avenue

Temple Terrace, Florida 33617
LAST KNOWN ADDRESSES STATED, CURRENT RESIDENCES UNKNOWN

YOU ARE HEREBY NOTIFIED that an action for Foreclosure of Mortgage on the following described property: LOT 1, 2, 3 AND 4, BLOCK F30 AND LOT 4, BLOCK F26, LAKE-SIDE ESTATES, INC., UNIT NO. 1, ACCORDING TO THE MAP OR PLAT THEREOF, AS RECORDED IN PLAT BOOK 6, PAGE(S) 17, OF THE PUBLIC RECORDS OF PASCO COUNTY, FLORIDA, AND VACATED ALLEY LYING BETWEEN LOTS 2 AND 3, BLOCK 30 AND VACATED DESOTA LANE LYING BETWEEN LOT 1, BLOCK F30 AND LOT 4, BLOCK F26, AS PER RESOLUTION #78-68 RECORDED IN OFFICIAL RECORDS BOOK 922, PAGE 987, ALL FURTHER DESCRIBED AS FOLLOWS: BEGIN AT THE SOUTHWEST CORNER OF LOT 4, BLOCK F30, LAKESIDE ESTATES, INC., UNIT 1, AND RUN NORTH ALONG THE WESTERLY

BOUNDARY AND NORTHERLY EXTENSION THEREOF 490.00 FEET; THENCE EAST 150.00 FEET; THENCE SOUTH 490.00 FEET; THENCE WEST 150.00 FEET TO THE POINT OF BEGINNING, LYING IN SECTION 28, TOWNSHIP 25 SOUTH, RANGE 20 EAST, PUBLIC RECORDS OF PASCO COUNTY, FLORIDA.

has been filed against you and you are required to file a copy of your written defenses, if any, to it on Charles P. Gufford, McCalla Raymer Leibert Pierce, LLP, 225 East Robinson Street, Suite 155, Orlando, FL 32801 and file the original with the Clerk of the above-styled Court on or before July 6, 2026 or 30 days from the first publication, otherwise a Judgment may be entered against you for the relief demanded in the Complaint.

If you are a person with a disability who needs an accommodation in order to participate in this proceeding, you are entitled, at no cost to you, to the provision of certain assistance. Please contact the Public Information Dept., Pasco County Government Center, 7530 Little Rd., New Port Richey, FL 34654; (727)

847-8110 (V) in New Port Richey; (352) 521-4274, ext 8110 (V) in Dade City, at least 7 days before your scheduled court appearance, or immediately upon receiving this notification if the time before the scheduled appearance is less than 7 days; if you are hearing impaired call 711. The court does not provide transportation and cannot accommodate for this service. Persons with disabilities needing transportation to court should contact their local public transportation providers for information regarding transportation services.

WITNESS my hand and seal of this Court this 1 day of June, 2026.

NIKKI ALVAREZ-SOWLES, ESQ.,
CLERK OF COURT OF
PASCO COUNTY
As Clerk of the Court
(SEAL) BY: Shakira Ramirez Pagan
Deputy Clerk

MCCALLA RAYMER LEIBERT
PIERCE, LLP
225 East Robinson Street, Suite 155,
Orlando, FL 32801
Phone: (407) 674-1850
Fax: (321) 248-0420
Email:AccountsPayables@mccalla.com
25-14681FL
June 5, 12, 2026 26-01304P

SECOND INSERTION

NOTICE OF SALE
IN THE COUNTY COURT OF THE SIXTH JUDICIAL CIRCUIT OF FLORIDA IN AND FOR PASCO COUNTY, FLORIDA

CASE NO: 25-CC-6972
ARBORWOOD AT SUMMERTREE, INC. a Florida not-for-profit corporation,
Plaintiff, vs.
ESTATE OF ANN COLLETTI, ANY AND ALL UNKNOWN HEIRS, SECRETARY OF HOUSING AND URBAN DEVELOPMENT and ANY UNKNOWN OCCUPANTS IN POSSESSION,
Defendants.

NOTICE IS HEREBY GIVEN that, pursuant to the Summary Final Judgment in this cause, in the County Court of Pasco County, Florida, the Clerk of Court will sell all the property situated in Pasco County, Florida described as:

Lot 272, ARBORWOOD AT SUMMERTREE, according to the plat thereof, recorded in Plat Book 22, Page 50 through 63, Public Records of Pasco County, Florida. Property Address: 11627 Aspenwood Drive, New Port Richey, Florida 34654.

at public sale, to the highest and best bidder, for cash, at www.pasco.realforeclose.com, at 11:00 A.M. on July 2, 2026.

Any person claiming an interest in the surplus from the sale, if any, must

file a claim with the Clerk no later than the date that the Clerk reports the funds as unclaimed.

If you are a person with a disability who needs an accommodation in order to participate in this proceeding, you are entitled, at no cost to you, to the provision of certain assistance. Please contact the Public Information Dept., Pasco County Government Center, 7530 Little Rd., New Port Richey, FL 34654; (727) 847-8110 (V) in New Port Richey; (352) 521-4274, ext 8110 (V) in Dade City, at least 7 days before your scheduled court appearance, or immediately upon receiving this notification if the time before the scheduled appearance is less than 7 days; if you are hearing impaired call 711. The court does not provide transportation and cannot accommodate for this service. Persons with disabilities needing transportation to court should contact their local public transportation providers for information regarding transportation services.

Dated this 2nd day of June, 2026.

NIKKI ALVAREZ-SOWLES, ESQ.,
CLERK OF THE CIRCUIT COURT
s/ Stephan C. Nikoloff
Stephan C. Nikoloff
(Steve@associationlawfl.com)
Bar Number 56592
Attorney for Plaintiff
1964 Bayshore Boulevard, Suite A
Dunedin, Florida 34698
Telephone: (727) 738-1100
June 5, 12, 2026 26-01312P

SECOND INSERTION

NOTICE OF FORECLOSURE SALE
IN THE CIRCUIT COURT OF THE 6TH JUDICIAL CIRCUIT, IN AND FOR PASCO COUNTY, FLORIDA
CIVIL DIVISION

CASE NO.
2024CA000841CAAXWS
U.S. BANK TRUST NATIONAL ASSOCIATION NOT IN ITS INDIVIDUAL CAPACITY BUT SOLELY AS OWNER TRUSTEE FOR RCF 2 ACQUISITION TRUST,
Plaintiff, vs.
MICHAEL J. KRIETEMEYER A/K/A MICHAEL KRIETEMEYER; JENNIFER KRIETEMEYER; U.S. BANK NATIONAL ASSOCIATION, NOT IN ITS INDIVIDUAL CAPACITY BUT SOLELY AS TRUSTEE OF NRZ RECOVERY TRUST; UNKNOWN PERSON(S) IN POSSESSION OF THE SUBJECT PROPERTY,
Defendant(s)

NOTICE IS HEREBY GIVEN pursuant to a Final Judgment of Foreclosure filed May 8, 2026 and entered in Case No. 2024CA000841CAAXWS, of the Circuit Court of the 6th Judicial Circuit in and for PASCO County, Florida, wherein U.S. BANK TRUST NATIONAL ASSOCIATION NOT IN ITS INDIVIDUAL CAPACITY BUT SOLELY AS OWNER TRUSTEE FOR RCF 2 ACQUISITION TRUST is Plaintiff and MICHAEL J. KRIETEMEYER A/K/A MICHAEL KRIETEMEYER; JENNIFER KRIETEMEYER; UNKNOWN PERSON(S) IN POSSESSION OF THE SUBJECT PROPERTY; U.S. BANK NATIONAL ASSOCIATION, NOT IN ITS INDIVIDUAL CAPACITY BUT SOLELY AS TRUSTEE OF NRZ RECOVERY TRUST; are defendants, NIKKI ALVAREZ-SOWLES, ESQ., the Clerk of the Circuit Court, will sell to the highest and best bidder for cash

BY ELECTRONIC SALE AT: WWW.PASCO.REALFORECLOSE.COM, at 11:00 A.M., on June 23, 2026, the following described property as set forth in said Final Judgment, to wit:

LOT 50, RIDGEWOOD UNIT TWO, ACCORDING TO THE PLAT THEREOF, AS RECORDED IN PLAT BOOK 24, PAGES 136 AND 137, OF THE PUBLIC RECORDS OF PASCO COUNTY, FLORIDA.

Any person claiming an interest in the surplus from the sale, if any, other than the property owner as of the date of the lis pendens must file a claim before the Clerk reports the surplus as unclaimed.

This notice is provided pursuant to Administrative Order 2010-045 PA/PI-CIR "If you are a person with disability who needs an accommodation in order to participate in this proceeding, you are entitled, at no cost to you the provision of certain assistance. Please contact Public Information Dept., Pasco County Government Center, 7530 Little Rd., New Port Richey, FL 34654; (727) 847-8110 (V) for proceedings in New Port Richey; (352) 521-4274, ext. 8110 (V) for proceedings in Dade City at least 7 days before your scheduled court appearance, or immediately upon receiving this notification if the time before the scheduled appearance is less than 7 days; if you are hearing or voice impaired, call 711."

Dated this 27th day of May 2026.
By: /s/ Marc Granger, Esq.
Bar No.: 1468701
Kahane & Associates, P.A.
1619 NW 136th Avenue,
Suite D-220
Sunrise, Florida 33323
Telephone: (954) 382-3486
Telefacsimile: (954) 382-5380
Designated service email:
notice@kahaneandassociates.com
File No.: 24-00311 SF
June 5, 12, 2026 26-01279P

SECOND INSERTION

NOTICE OF FORECLOSURE SALE
IN THE CIRCUIT COURT OF THE SIXTH JUDICIAL CIRCUIT OF FLORIDA IN AND FOR PASCO COUNTY

GENERAL JURISDICTION DIVISION
CASE NO. 2025CA003828CAAXES
LAKEVIEW LOAN SERVICING, LLC,
Plaintiff, vs.
DAVID GRAY, et al.,
Defendant.

NOTICE IS HEREBY GIVEN pursuant to a Summary Final Judgment of Foreclosure entered May 26, 2026 in Civil Case No. 2025CA003828CAAXES of the Circuit Court of the SIXTH JUDICIAL CIRCUIT in and for Pasco County, Dade City, Florida, wherein LAKEVIEW LOAN SERVICING, LLC is Plaintiff and David Gray, et al., are Defendants, the Clerk of Court, NIKKI ALVAREZ-SOWLES, ESQ., will sell to the highest and best bidder for cash electronically at www.pasco.realforeclose.com in accordance with Chapter 45, Florida Statutes on the 24th day of June, 2026 at 11:00 AM on the following described property as set forth in said Summary Final Judgment, to-wit:

Lot 43, Greens at Hidden Creek, a subdivision according to the plat thereof recorded at Plat Book 57, Pages 147 through 153, inclusive, of the Public Records of Pasco County, Florida.

Any person claiming an interest in the surplus from the sale, if any, other than the property owner as of the date of the lis pendens, must file a claim before the clerk reports the surplus as unclaimed.

If you are a person with a disability who needs an accommodation in order to participate in this proceeding, you are entitled, at no cost to you to the provision of certain assistance. Within two (2) working days of your receipt of this (describe notice/order) please contact the Public Information Dept., Pasco County Government Center, 7530 Little Rd., New Port Richey, FL 34654; (727) 847-8110 (V) in New Port Richey; (352) 521-4274, ext. 8110 (V) in Dade City; via 1-800-955-8771 if you are hearing impaired. The court does not provide transportation and cannot accommodate for this service. Persons with disabilities needing transportation to court should contact their local public transportation providers for information regarding disabled transportation services.

/s/Robyn Katz
Robyn Katz, Esq.
McCalla Raymer Leibert Pierce, LLP
Attorney for Plaintiff
225 East Robinson Street, Suite 155
Orlando, FL 32801
Phone: (407) 674-1850
Fax: (321) 248-0420
Email: MRService@mccalla.com
Fla. Bar No.: 146803
25-13710FL
June 5, 12, 2026 26-01286P

SECOND INSERTION

NOTICE OF FORECLOSURE SALE
IN THE CIRCUIT COURT OF THE SIXTH JUDICIAL CIRCUIT OF FLORIDA IN AND FOR PASCO COUNTY

GENERAL JURISDICTION DIVISION
CASE NO. 2019 CA 001161
U.S. BANK NATIONAL ASSOCIATION, AS TRUSTEE, SUCCESSOR IN INTEREST TO BANK OF AMERICA, NATIONAL ASSOCIATION, AS TRUSTEE, SUCCESSOR BY MERGER TO LASALLE BANK NATIONAL ASSOCIATION, AS TRUSTEE FOR MERRILL LYNCH MORTGAGE INVESTORS TRUST, MORTGAGE LOAN ASSET-BACKED CERTIFICATES, SERIES 2006-FF1,
Plaintiff, vs.
DAVID R. VOGEL A/K/A DAVID VOGEL, et al.,
Defendant.

NOTICE OF FORECLOSURE SALE

NOTICE IS HEREBY GIVEN pursuant to a Summary Final Judgment of Foreclosure entered July 27, 2023 in Civil Case No. 2019 CA 001161 of the Circuit Court of the SIXTH JUDICIAL CIRCUIT in and for Pasco County, Dade City, Florida, wherein U.S. BANK NATIONAL ASSOCIATION, AS TRUSTEE, SUCCESSOR IN INTEREST TO BANK OF AMERICA, NATIONAL ASSOCIATION, AS TRUSTEE, SUCCESSOR BY MERGER TO LASALLE BANK NATIONAL ASSOCIATION, AS TRUSTEE FOR MERRILL LYNCH MORTGAGE INVESTORS TRUST, MORTGAGE LOAN ASSET-BACKED CERTIFICATES, SERIES 2006-FF1 is Plaintiff and David R. Vogel a/k/a David Vogel, et al., are Defendants, the Clerk of Court, NIKKI ALVAREZ-SOWLES, ESQ., will sell to the highest and best bidder for cash electronically at www.pasco.realforeclose.com in accordance with Chapter 45, Florida Statutes on the 22nd day of June, 2026 at 11:00 AM on

the following described property as set forth in said Summary Final Judgment, to-wit:

LOT 651, BEAR CREEK SUB-DIVISION, UNIT FOUR, ACCORDING TO THE PLAT THEREOF AS RECORDED IN PLAT BOOK 23, PAGE(S) 135 THROUGH 137, OF THE PUBLIC RECORDS OF PASCO COUNTY, FLORIDA.

Any person claiming an interest in the surplus from the sale, if any, other than the property owner as of the date of the lis pendens, must file a claim before the clerk reports the surplus as unclaimed.

If you are a person with a disability who needs an accommodation in order to participate in this proceeding, you are entitled, at no cost to you to the provision of certain assistance. Within two (2) working days of your receipt of this (describe notice/order) please contact the Public Information Dept., Pasco County Government Center, 7530 Little Rd., New Port Richey, FL 34654; (727) 847-8110 (V) in New Port Richey; (352) 521-4274, ext. 8110 (V) in Dade City; via 1-800-955-8771 if you are hearing impaired. The court does not provide transportation and cannot accommodate for this service. Persons with disabilities needing transportation to court should contact their local public transportation providers for information regarding disabled transportation services.

/s/Robyn Katz
Robyn Katz, Esq.
McCalla Raymer Leibert Pierce, LLP
Attorney for Plaintiff
225 East Robinson Street,
Suite 155
Orlando, FL 32801
Phone: (407) 674-1850
Fax: (321) 248-0420
Email: MRService@mccalla.com
Fla. Bar No.: 146803
19-00487FL
June 5, 12, 2026 26-01280P

--- ACTIONS / SALES ---

SECOND INSERTION

NOTICE OF ACTION
IN THE CIRCUIT COURT OF THE
SIXTH JUDICIAL CIRCUIT IN AND
FOR PASCO COUNTY, FLORIDA

CASE NO.:
2024CA000874CAAXWS
PNC BANK, NATIONAL
ASSOCIATION,
Plaintiff, vs.
FRANK MARTELLO, AS
SUCCESSOR TRUSTEE OF
THE PATRICIA A. MARTELLO
TRUST AGREEMENT DATED
SEPTEMBER 8, 2022, ET AL.,
Defendants.

To the Following Defendant:
BEAR CREEK VILLAGE OWNERS
ASSOCIATION, INC.
7516 BEACON WOODS DRIVE
BAYONET POINT, FL 34667

and all parties claiming interest by,
through, under or against Defendant
Bear Creek Village Owners Association,
Inc., and all parties having or claiming
to have any right, title, or interest in the
property herein described;

YOU ARE NOTIFIED that an
action to foreclose a mortgage on the
following real property in Pasco
County, Florida:

Lot 433, Bear Creek Unit Five, ac-
cording to the map or plat thereof
as recorded in Plat Book 25, Page
9, Public Records of Pasco County,
Florida.
commonly known as 11334
Stoneybrook Path, Port Richey, FL
34668,

has been filed against you and you are
required to serve a copy of your written
defenses, if any, upon Lauren Raines,
Esq., Plaintiff's attorney, whose address
is Bradley Arant Bault Cummings, LLP,
1001 Water Street, Suite 1000, Tampa,
FL 33602, within thirty (30) days after

the first publication of this Notice and
file the original with the Clerk of this
Court either before service on Plain-
tiff's attorney or immediately thereaf-
ter; otherwise a default will be entered
against you for the relief demanded in
the Complaint. DUE ON OR BEFORE
JULY 6, 2026

If you are a person with a disability
who needs an accommodation in order
to participate in this proceeding, you
are entitled, at no cost to you, to the
provision of certain assistance. Please
contact: Public Information Dept., Pas-
co County Government Center, 7530

Little Rd., New Port Richey, FL 34654
Phone: 727.847.8110 (voice) in New
Port Richey or 352.521.4274, ext 8110
(voice) in Dade City or 711 for the hear-
ing impaired.

Contact should be initiated at least
seven days before the scheduled court
appearance, or immediately upon re-
ceiving this notification if the time be-
fore the scheduled appearance is less
than seven days.

The court does not provide trans-
portation and cannot accommodate
such requests. Persons with disabilities
needing transportation to court should

contact their local public transportation
providers for information regarding
transportation services.

DATED ON June 2, 2026
Nikki Alvarez-Sowles
Clerk of the Circuit Court
Pasco County Clerk & Comptroller
By: Shakira Ramirez Pagan
Deputy Clerk

Submitted by:
Lauren G. Raines
Bradley Arant Bault Cummings LLP
1001 Water Street, Suite 1000
Tampa, FL 33602
June 5, 12, 2026 26-01308P

SECOND INSERTION

NOTICE OF ACTION -
CONSTRUCTIVE SERVICE
IN THE CIRCUIT COURT OF THE
SIXTH JUDICIAL CIRCUIT IN AND
FOR PASCO COUNTY, FLORIDA
GENERAL JURISDICTION
DIVISION

Case No. **2026CA001589CAAXES**
Freedom Mortgage Corporation
Plaintiff, vs.
The Unknown Heirs, Devisees,
Grantees, Assignees, Lienors,
Creditors, Trustees, and all other
parties claiming interest by, through,
under or against the Estate of
Ronald G. Kroll Jr., Deceased;
Jessica M. Rainsberger, Personal
Representative of the Estate of
Ronald G. Kroll Jr., Deceased; et al
Defendants.

TO: The Unknown Heirs, Devisees,
Grantees, Assignees, Lienors, Creditors,
Trustees, and all other parties claiming
interest by, through, under or against
the Estate of Ronald G. Kroll, Jr.,
Deceased

Last Known Address: Unknown
YOU ARE HEREBY NOTIFIED that
an action to foreclose a mortgage on the
following property in Pasco County,
Florida:

THE EAST 130.85 FEET OF
TRACT 84, ZEPHYRHILLS
COLONY COMPANY LANDS,
IN SECTION 15, TOWNSHIP
26 SOUTH, RANGE 21 EAST,
AS RECORDED IN PLAT
BOOK L PAGE 55, OF THE
PUBLIC RECORDS OF PASCO
COUNTY, FLORIDA.
TOGETHER WITH AN EASE-
MENT FOR INGRESS AND
EGRESS OVER AND ACROSS
THE SOUTH 10 FEET OF THE
WEST 534.00 FEET OF TRACT
84, ZEPHYRHILLS COLONY
COMPANY LANDS, IN SEC-
TION 15, TOWNSHIP 26
SOUTH, RANGE 21 EAST,
AS RECORDED IN PLAT
BOOK 1 PAGE 55, OF THE
PUBLIC RECORDS OF PASCO
COUNTY, FLORIDA.
TOGETHER WITH AN EASE-
MENT FOR INGRESS AND
EGRESS OVER AND ACROSS
THE SOUTH 10 FEET OF THE
WEST 534.00 FEET OF TRACT
84, ZEPHYRHILLS COLONY
COMPANY LANDS, IN SEC-
TION 15, TOWNSHIP 26
SOUTH, RANGE 21 EAST,
AS RECORDED IN PLAT
BOOK 1 PAGE 55, OF THE
PUBLIC RECORDS OF PASCO
COUNTY, FLORIDA.
TOGETHER WITH AN EASE-

MENT FOR INGRESS AND
EGRESS OVER AND ACROSS
THE SOUTH 10 FEET OF THE
WEST 534.00 FEET OF TRACT
84, ZEPHYRHILLS COLONY
COMPANY LANDS, IN SEC-
TION 15, TOWNSHIP 26
SOUTH, RANGE 21 EAST, AS
RECORDED IN PLAT BOOK 1,
PAGE 55, OF THE PUBLIC RE-
CORDS OF PASCO COUNTY,
FLORIDA, BEING SUBJECT
TO A ROAD RIGHT-OF-WAY
OVER AND ACROSS THE
WEST 10 FEET THEREOF.

has been filed against you and you are
required to serve a copy of your written
defenses, if any, to it on Julie York, Es-
quire, Brock & Scott, PLLC., the Plain-
tiff's attorney, whose address is 4919
Memorial Hwy, Suite 135, Tampa, FL
33634, within thirty (30) days of the
first date of publication on or before
July 6, 2026, and file the original with
the Clerk of this Court either before ser-
vice on the Plaintiff's attorney or imme-
diately thereafter; otherwise a default
will be entered against you for the relief
demanded in the complaint or petition.

THIS NOTICE SHALL BE PUBLISHED
ONCE A WEEK FOR TWO
(2) CONSECUTIVE WEEKS

If you are a person with a disability
who needs any accommodation in order
to participate in this proceeding, you
are entitled, at no cost to you, to the
provision of certain assistance. Please
contact the Public Information Dept.,
Pasco County Government Center, 7530
Little Rd., New Port Richey, FL 34654;
(727) 847-8110 (V) in New Port Richey;
(352) 521-4274, ext 8110 (V) in Dade
City, at least 7 days before your sched-
uled court appearance, or immediately
upon receiving this notification if the
time before the scheduled appearance
is less than 7 days; if you are hearing
impaired call 711. The court does not
provide transportation and cannot
accommodate for this service. Persons
with disabilities needing transportation
to court should contact their local
public transportation providers for
information regarding transportation
services.

DATED on June 2, 2026.
Nikki Alvarez-Sowles
As Clerk of the Court
(SEAL) By /s/ Shakira Ramirez Pagan
As Deputy Clerk

Brock & Scott, PLLC.,
the Plaintiff's Attorney
4919 Memorial Hwy, Suite 135,
Tampa, FL 33634
File # 26-F01702
June 5, 12, 2026 26-01310P

SECOND INSERTION

NOTICE OF ACTION
IN THE CIRCUIT COURT OF THE
SIXTH JUDICIAL CIRCUIT OF
FLORIDA IN AND FOR PASCO
COUNTY

CASE NO. **2026CA000982CAAXES**
LAKEVIEW LOAN SERVICING,
LLC,
Plaintiff, vs.
CANDICE SEWARD, et al.,
Defendant.

ANY AND ALL UNKNOWN PARTIES
CLAIMING BY, THROUGH,
UNDER, AND AGAINST ESTATE OF
PAULA N MARTANIUK A/K/A PAU-
LA MARTANIUK, WHETHER SAID
UNKNOWN PARTIES MAY CLAIM
AN INTEREST AS SPOUSES, HEIRS,
DEVISEES, GRANTEEES, OR OTHER
CLAIMANTS

YOU ARE HEREBY NOTIFIED that
an action for Foreclosure of Mortgage
on the following described property:

LOT 6, WILLOW BEND TRACT
MF-2, ACCORDING TO THE
MAP OR PLAT THEREOF, AS
RECORDED IN PLAT BOOK 35,
PAGE(S) 102 THROUGH 106,
INCLUSIVE, OF THE PUBLIC
RECORDS OF PASCO COUNTY,
FLORIDA

has been filed against you and you are
required to file a copy of your writ-
ten defenses, if any, to it on McCalla
Raymer Leibert Pierce, LLP, Jamie
Juster, Attorney for Plaintiff, 225 East
Robinson Street, Suite 155, Orlando,
FL 32801 and file the original with the
Clerk of the above-styled Court on or
before July 6, 2026 or 30 days from the
first publication, otherwise a Judgment

may be entered against you for the relief
demanded in the Complaint.

If you are a person with a disability
who needs any accommodation in order
to participate in this proceeding, you are
entitled, at no cost to you, to the pro-
vision of certain assistance. Please contact
the Public Information Dept., Pasco
County Government Center, 7530 Little
Rd., New Port Richey, FL 34654; (727)
847-8110 (V) in New Port Richey; (352)
521-4274, ext 8110 (V) in Dade City, at
least 7 days before your scheduled court
appearance, or immediately upon re-
ceiving this notification if the time be-
fore the scheduled appearance is less
than 7 days; if you are hearing impaired
call 711. The court does not provide
transportation and cannot accommo-
date for this service. Persons with dis-
abilities needing transportation to court
should contact their local public trans-
portation providers for information re-
garding transportation services.

WITNESS my hand and seal of this
Court this 28 day of May, 2026.

NIKKI ALVAREZ-SOWLES, ESQ.
CLERK OF COURT OF
PASCO COUNTY
As Clerk of the Court
(SEAL) BY: Shakira Ramirez Pagan
Deputy Clerk

MCCALLA RAYMER LEIBERT
PIERCE, LLP
225 East Robinson Street, Suite 155,
Orlando, FL 32801
Phone: (407) 674-1850
Fax: (321) 248-0420
Email:AccountsPayables@mccalla.com
25-15467FL
June 5, 12, 2026 26-01287P

SECOND INSERTION

NOTICE OF ACTION -
CONSTRUCTIVE SERVICE
IN THE CIRCUIT COURT OF THE
SIXTH JUDICIAL CIRCUIT IN AND
FOR PASCO COUNTY,
FLORIDA
GENERAL JURISDICTION
DIVISION
CASE NO.

2026CA000353CAAXES
DEUTSCHE BANK NATIONAL
TRUST COMPANY, AS TRUSTEE
FOR HARBORVIEW MORTGAGE
LOAN TRUST MORTGAGE LOAN
PASS-THROUGH CERTIFICATES,
SERIES 2006-5,
Plaintiff, vs.
THE UNKNOWN HEIRS,
BENEFICIARIES, DEVISEES,
GRANTEES, ASSIGNEES,
LIENORS, CREDITORS,
TRUSTEES AND ALL OTHERS
WHO MAY CLAIM AN INTEREST
IN THE ESTATE OF RALPH
WARBURTON, DECEASED. et. al.
Defendant(s),

TO: THE UNKNOWN HEIRS,
BENEFICIARIES, DEVISEES,
GRANTEES, ASSIGNEES, LIENORS,
CREDITORS, TRUSTEES AND ALL
OTHERS WHO MAY CLAIM AN
INTEREST IN THE ESTATE OF
RALPH WARBURTON, DECEASED,
whose residence is unknown if he/
she/they be living; and if he/she/they
are dead, the unknown defendants
who may be spouses, heirs, devisees,
grantees, assignees, lienors, creditors,
trustees, and all parties claiming an
interest by, through, under or against
the Defendants, who are not known to
be dead or alive, and all parties having
or claiming to have any right, title or
interest in the property described in the
mortgage being foreclosed herein.

YOU ARE HEREBY NOTIFIED that
an action to foreclose a mortgage on the
following property:

THE EAST 73.0 FEET OF LOTS
8, 9 AND 10, BLOCK 21, CITY
OF ZEPHYRHILLS, ACCORD-
ING TO THE PLAT THERE-
OF, AS RECORDED IN PLAT
BOOK 1, PAGE 54 OF THE

PUBLIC RECORDS OF PASCO
COUNTY, FLORIDA.

has been filed against you and you are
required to serve a copy of your writ-
ten defenses, if any, to it on counsel for
Plaintiff, whose address is 6409 Con-
gress Ave., Suite 100, Boca Raton, Flori-
da 33487 on or before JULY 6, 2026/
(30 days from Date of First Publication
of this Notice) and file the original with
the clerk of this court either before ser-
vice on Plaintiff's attorney or immedi-
ately thereafter; otherwise a default
will be entered against you for the relief
demanded in the complaint or petition
filed herein.

If you are a person with a disability
who needs any accommodation in order
to participate in this proceeding, you
are entitled, at no cost to you, to the
provision of certain assistance. Please
contact the Public Information Dept.,
Pasco County Government Center,
7530 Little Rd., New Port Richey, FL
34654; (727) 847-8110 (V) in New Port
Richey; (352) 521-4274, ext 8110 (V) in
Dade City, at least 7 days before your
scheduled court appearance, or imme-
diately upon receiving this notification
if the time before the scheduled appear-
ance is less than 7 days; if you are hear-
ing impaired call 711. The court does
not provide transportation and cannot
accommodate for this service. Persons
with disabilities needing transporta-
tion to court should contact their local
public transportation providers for
information regarding transportation
services.

WITNESS my hand and the seal of
this Court at Pasco County, Florida, this
May 29, 2026

Nikki Alvarez-Sowles
Pasco County Clerk & Comptroller
(Seal) By: Shakira Ramirez Pagan
Deputy Clerk

ROBERTSON, ANSCHUTZ, AND
SCHNEID, PL
ATTORNEY FOR PLAINTIFF
6409 Congress Ave., Suite 100
Boca Raton, FL 33487
PRIMARY EMAIL: flmail@raslg.com
25-345304
June 5, 12, 2026 26-01293P

SECOND INSERTION

NOTICE OF SALE
IN THE CIRCUIT COURT OF THE
SIXTH JUDICIAL CIRCUIT IN AND
FOR PASCO COUNTY, STATE OF
FLORIDA CIVIL DIVISION
CASE NO.:

2024CA000530CAAXWS
ADVANTA IRA SERVICES, LLC
f/b/o IRA #8004820,
Plaintiff, vs.
JOHN R. LEYDEN and SUSAN
S. LEYDEN, Husband and wife;
JOHN ROBERT LEYDEN,
Individually; STATE OF FLORIDA,
DEPARTMENT OF REVENUE;
JOHN DOE, JANE DOE and
UNKNOWN HEIRS OF JOHN R.
LEYDEN
Defendants.

Notice is hereby given that, pursuant to
the Amended Uniform Final Judgment
of Foreclosure entered in this cause on
May 6, 2026, the Clerk of the Court will
sell the real property situated in Pasco
County, Florida, described as:

Parcel 1:
Lot 1, Block A, SUNSET ES-
TATES, according to plat thereof
as recorded in Plat Book 5, Page
165, Public Records of Pasco Coun-
ty, Florida.
Parcel ID #
27-24-16-0130-00A00-0010
Parcel 2:
Lot 2, Block A, SUNSET ES-
TATES, according to plat thereof
as recorded in Plat Book 5, Page
165, Public Records of Pasco Coun-
ty, Florida.
Parcel ID #
27-24-16-0130-00A00-0020
Parcel 3:
The West 100 feet of the North
125 feet of the North Half (N 1/2)
of Lot 19, Block A, and the East
50 feet of the West 150 feet of the
North 125 feet of the North Half
(N 1/2) of said Lot 19, Block A,
U.S. 19 NO. 9 ADDN, according

to plat thereof as recorded in Plat
Book 5, Page 66 of the Public Re-
cords of Pasco County, Florida.
Property address: 7436 New York
Ave., Hudson, Florida 34667
Parcel ID #
27-24-16-0010-00A00-0192

at public sale, to the highest and
best bidder, for CASH, such sale to
be held online at [http://www.pasco.
realforeclose.com](http://www.pasco.realforeclose.com), beginning at 11:00
a.m. on August 11, 2026. Any person
claiming an interest in the surplus from
the sale, if any, other than the property
owner as of the date of the lis pendens,
must file a claim within 60 days after
the sale.

If you are a person with a disability
who needs any accommodation in order
to access court facilities or to partici-
pate in a court proceeding, you are
entitled, at no cost to you, to the pro-
vision of certain assistance. To request
such an accommodation, please con-
tact the Sixth Judicial Circuit Court's
ADA Coordinator at least seven days
before your scheduled court appear-
ance, or immediately upon receiving
this notification if the time before
the scheduled appearance is less than
seven days. If you are hearing or voice
impaired, call 711. The Court's ADA
Coordinator web page link below
details the nature of the accommoda-
tions that can be provided by the
Florida Courts under the ADA.
Steven F. Thompson, Esq.
Florida Bar No. 0063053
stthompson@thompsonclg.com
Tyler J. Caron, Esq.
Florida Bar No. 0100185
tcaron@thompsonclg.com
Thompson Commercial Law Group
615 W. DeLeon Street
Tampa, Florida 33606
Telephone: (813) 387-1821
Telecopier: (813) 387-1824
Attorneys for the Plaintiff.
June 5, 12, 2026 26-01299P

SECOND INSERTION

NOTICE OF ACTION -
CONSTRUCTIVE SERVICE
IN THE CIRCUIT COURT OF THE
SIXTH JUDICIAL CIRCUIT IN AND
FOR PASCO COUNTY,
FLORIDA
GENERAL JURISDICTION
DIVISION

CASE NO. **2025CA002674CAAXWS**
NATIONSTAR MORTGAGE LLC,
Plaintiff, vs.
THE UNKNOWN HEIRS,
BENEFICIARIES, DEVISEES,
GRANTEES, ASSIGNEES,
LIENORS, CREDITORS,
TRUSTEES AND ALL OTHERS
WHO MAY CLAIM AN INTEREST
IN THE ESTATE OF CHRYSOULA
BALATSAS, DECEASED. et. al.
Defendant(s),

TO: THE UNKNOWN HEIRS,
BENEFICIARIES, DEVISEES,
GRANTEES, ASSIGNEES, LIENORS,
CREDITORS, TRUSTEES AND
ALL OTHERS WHO MAY CLAIM
AN INTEREST IN THE ESTATE
OF CHRYSOULA BALATSAS,
DECEASED,
whose residence is unknown if he/
she/they be living; and if he/she/they
be dead, the unknown defendants
who may be spouses, heirs, devisees,
grantees, assignees, lienors, creditors,
trustees, and all parties claiming an
interest by, through, under or against
the Defendants, who are not known to
be dead or alive, and all parties having
or claiming to have any right, title or
interest in the property described in the
mortgage being foreclosed herein.

YOU ARE HEREBY NOTIFIED that
an action to foreclose a mortgage on the
following property:

LOT 118, CYPRESS LAKES
UNIT 3, PHASE 1, ACCORD-
ING TO THE MAP OR PLAT
THEREOF AS RECORDED
IN PLAT BOOK 30, PAGES 59
THROUGH 61, INCLUSIVE,
OF THE PUBLIC RECORDS
OF PASCO COUNTY, FLORI-
DA.

has been filed against you and you are
required to serve a copy of your writ-
ten defenses, if any, to it on counsel for
Plaintiff, whose address is 6409 Con-
gress Ave., Suite 100, Boca Raton, Flori-
da 33487 on or before JULY 6, 2026/
(30 days from Date of First Publica-
tion of this Notice) and file the original
with the clerk of this court either before
service on Plaintiff's attorney or immedi-
ately thereafter; otherwise a default
will be entered against you for the relief
demanded in the complaint or petition
filed herein.

If you are a person with a disability
who needs any accommodation in order
to participate in this proceeding, you
are entitled, at no cost to you, to the
provision of certain assistance. Please
contact the Public Information Dept.,
Pasco County Government Center,
7530 Little Rd., New Port Richey, FL
34654; (727) 847-8110 (V) in New Port
Richey; (352) 521-4274, ext 8110 (V) in
Dade City, at least 7 days before your
scheduled court appearance, or imme-
diately upon receiving this notification
if the time before the scheduled appear-
ance is less than 7 days; if you are hear-
ing impaired call 711. The court does
not provide transportation and cannot
accommodate for this service. Persons
with disabilities needing transporta-
tion to court should contact their local
public transportation providers for
information regarding transportation
services.

WITNESS my hand and the seal of
this Court at Pasco County, Florida, this
June 1, 2026

Nikki Alvarez-Sowles
Pasco County Clerk & Comptroller
(Seal) By: Shakira Ramirez Pagan
Deputy Clerk

ROBERTSON, ANSCHUTZ, AND
SCHNEID, PL
ATTORNEY FOR PLAINTIFF
6409 Congress Ave., Suite 100
Boca Raton, FL 33487
PRIMARY EMAIL: flmail@raslg.com
25-326995
June 5, 12, 2026 26-01305P

SECOND INSERTION

NOTICE OF FORECLOSURE SALE
PURSUANT TO CHAPTER 45
IN THE CIRCUIT COURT OF THE
SIXTH JUDICIAL CIRCUIT IN AND
FOR PASCO COUNTY, FLORIDA
CASE NO.: 2025CA002766

ONSLOW BAY FINANCIAL, LLC.,
Plaintiff, vs.
THE ESTATE OF GREGG
KESSLER, DECEASED;
MATTHEW KESSLER,
INDIVIDUALLY AND AS
CO-PERSONAL
REPRESENTATIVE OF THE
ESTATE OF GREGG KESSLER,
DECEASED; CLIFTON KESSLER,
INDIVIDUALLY AND AS
CO-PERSONAL
REPRESENTATIVE OF THE
ESTATE OF GREGG KESSLER,
DECEASED; MIRADA MASTER
HOMEOWNERS ASSOCIATION,
INC.; UNKNOWN TENANT #1;
UNKNOWN TENANT #2;
Defendant(s).

NOTICE IS HEREBY GIVEN that
sale will be made pursuant to an Order
or Final Judgment. Final Judgment
was awarded on May 15, 2026 in Civil
Case No. 2025CA002766, of the Cir-
cuit Court of the SIXTH Judicial
Circuit in and for Pasco County, Florida,
wherein, ONSLOW BAY FINANCIAL,
LLC, is the Plaintiff, and THE ESTATE
OF GREGG KESSLER, DECEASED;
MATTHEW KESSLER, INDIVIDU-
ALLY AND AS CO-PERSONAL REP-
RESENTATIVE OF THE ESTATE
OF GREGG KESSLER, DECEASED;
CLIFTON KESSLER, INDIVIDU-
ALLY AND AS CO-PERSONAL REP-
RESENTATIVE OF THE ESTATE
OF GREGG KESSLER, DECEASED;
MIRADA MASTER HOMEOWNERS
ASSOCIATION, INC. are Defendants.

The Clerk of the Court, Nikki
Alvarez-Sowles, Esq. will sell to the
highest bidder for cash at [www.pasco.
realforeclose.com](http://www.pasco.
realforeclose.com) on August 13, 2026
at 11:00:00 AM EST the following
described real property as set forth in
said Final Judgment, to wit:

LOT 110, BLOCK 23, MIRADA
PARCEL 16-1, ACCORDING
TO THE PLAT AS RECORDED
IN PLAT BOOK 80, PAGES 84
THROUGH 90, OF THE PUBLIC
RECORDS OF PASCO COUNTY,
FLORIDA.

Any person claiming an interest in the
surplus from the sale, if any, other than
the property owner as of the date of the
lis pendens must file a claim before the
clerk reports the surplus as unclaimed.

IMPORTANT
AMERICANS WITH DISABILITIES
ACT: If you are a person with a dis-
ability who needs an accommodation
in order to participate in this proceed-
ing, you are entitled, at no cost to you,
to the provision of certain assistance.
Please contact: Public Information
Dept., Pasco County Government Cen-
ter, 7530 Little Rd., New Port Richey,
FL 34654; Phone: 727.847.8110 (voice)
in New Port Richey, 352.521.4274, ext
8110 (voice) in Dade City, Or 711 for the
hearing impaired. Contact should be
initiated at least seven days before the
scheduled court appearance, or imme-
diately upon receiving this notification
if the time before the scheduled appear-
ance is less than seven days. The court
does not provide transportation and
cannot accommodate such requests.
Persons with disabilities needing trans-
portation to court should contact their
local public transportation providers
for information regarding transporta-
tion services.

Dated this 29th day of May, 2026.
ALDRIDGE PITE, LLP
Attorney for Plaintiff
401 W. Linton Blvd., Suite 202-B
Delray Beach, FL 33444
Telephone: 561-392-6391
Facsimile: 561-392-6965
By: /s/ Mola Bosland
Mola Bosland, Esq.
FBN: 30330
Primary E-Mail:
ServiceMail@aldridgepite.com
1184-2680B
June 5, 12, 2026 26-01303P