

PASCO COUNTY LEGAL NOTICES

--- PUBLIC NOTICES ---

FIRST INSERTION

**Notice of Public Hearing and Board of Supervisors Meeting of the Northwood Community Development District**

The Board of Supervisors (the "Board") of the Northwood Community Development District (the "District") will hold a public hearing and a meeting Monday, July 20, 2026, at 6:30 p.m., at the Northwood Clubhouse located at 27248 Big Sur Drive, Wesley Chapel, Florida 33544.

The purpose of the public hearing is to receive public comments on the proposed adoption of the District's fiscal year 2026-2027 proposed budget. A meeting of the Board will also be held where the Board may consider any other business that may properly come before it. A copy of the proposed budget and the agenda may be viewed on the District's website at [www.northwoodcdd.com](http://www.northwoodcdd.com) at least 2 days before the meeting or may be obtained by contacting the District Manager's office via email at [Christina.Newsome@inframark.com](mailto:Christina.Newsome@inframark.com) or via phone at (813) 873-7300.

The public hearing and meeting are open to the public and will be conducted in accordance with the provisions of Florida law for community development districts. They may be continued to a date, time, and place to be specified on the record at the hearing or meeting. There may be occasions when staff or Board members may participate by speaker telephone.

In accordance with the provisions of the Americans with Disabilities Act, any person requiring special accommodations because of a disability or physical impairment should contact the District Manager's office at least 48 hours prior to the meeting. If you are hearing or speech impaired, please contact the Florida Relay Service at 711 or 1-800-955-8771 (TTY), or 1-800-955-8770 (voice) for aid in contacting the District Manager's office.

Each person who decides to appeal any decision made by the Board with respect to any matter considered at the public hearing or meeting is advised that person will need a record of proceedings and that accordingly, the person may need to ensure that a verbatim record of the proceedings is made, including the testimony and evidence upon which such appeal is to be based.

Christina Newsome  
District Manager  
June 26, 2026 26-01456P

FIRST INSERTION

**DUPREE LAKES COMMUNITY DEVELOPMENT DISTRICT NOTICE OF PUBLIC HEARING TO CONSIDER THE ADOPTION OF THE FISCAL YEAR 2027 PROPOSED BUDGET(S); AND NOTICE OF REGULAR BOARD OF SUPERVISORS' MEETING.**

The Board of Supervisors ("Board") of the Dupree Lakes Community Development District ("District") will hold a public hearing and regular meeting as follows:

DATE: August 18, 2026  
TIME: 6:00 P.M.  
LOCATION: Dupree Lakes Clubhouse  
6255 Dupree Lakes Blvd.  
Land O'Lakes, FL 34639 Vista Dr.

The purpose of the public hearing is to receive comments and objections on the adoption of the District's proposed budget(s) for the fiscal year beginning October 1, 2026, and ending September 30, 2027 ("Proposed Budget"). A regular Board meeting of the District will also be held at the above time where the Board may consider any other business that may properly come before it. A copy of the agenda and Proposed Budget may be obtained at the offices of the District Manager, Government Management Services - Tampa, LLC, 4530 Eagle Falls Place, Tampa, FL 33619, (813) 344-4844 ("District Manager's Office"), during normal business hours, or by visiting the District's website at <https://www.dupreelakescdd.org/>.

The public hearing and meeting are open to the public and will be conducted in accordance with the provisions of Florida law. The public hearing and/or meeting may be continued in progress to a date, time certain, and place to be specified on the record at the public hearing and/or meeting. There may be occasions when Board Supervisors or District Staff may participate by speaker telephone.

Any person requiring special accommodations at the public hearing or meeting because of a disability or physical impairment should contact the District Manager's Office at least forty-eight (48) hours prior to the public hearing and meeting. If you are hearing or speech impaired, please contact the Florida Relay Service by dialing 7-1-1, or 1-800-955-8771 (TTY) / 1-800-955-8770 (Voice), for aid in contacting the District Manager's Office.

Each person who decides to appeal any decision made by the Board with respect to any matter considered at the public hearing or meeting is advised that person will need a record of proceedings and that accordingly, the person may need to ensure that a verbatim record of the proceedings is made, including the testimony and evidence upon which such appeal is to be based.

Jason Greenwood  
District Manager  
June 26; July 3, 2026 26-01453P

FIRST INSERTION

**NOTICE OF RULEMAKING REGARDING THE REVISED RULES OF PROCEDURE OF THE WESTWOOD OF PASCO COMMUNITY DEVELOPMENT DISTRICT**

In accordance with Chapters 120 and 190, Florida Statutes, the Westwood of Pasco Community Development District (the "District") hereby gives the public notice of its intent to adopt its proposed revised Rules of Procedure (the "Proposed Rule"). The Proposed Rule number is ROP-2026-1. Prior notice of rule development relative to the Proposed Rule was published in the Business Observer on June 19, 2026.

A public hearing will be conducted by the Board of Supervisors (the "Board") District on July 29, 2026, at 9:00 a.m. at SpringHill Suites Marriott Tampa Suncoast Parkway, 16615 Crosspointe Run, Land O'Lakes, Florida 34638, relative to the adoption of the Proposed Rule. Pursuant to Sections 190.011(5) and 190.012(3), Florida Statutes, the Proposed Rule will not require legislative ratification.

The summary of, purpose and effect of the revised Rules of Procedure is to provide for efficient and effective District operations and to ensure compliance with recent changes to Florida law. The specific grant of rulemaking authority for the adoption of the Proposed Rule includes Sections 190.011(5), 190.011(15) and 190.035, Florida Statutes. The specific laws implemented in the Proposed Rule include, but are not limited to, Sections 112.08, 112.3143, 112.31446, 112.3145, 119.07, 119.0701, 120.54, 120.542, 120.5435, 120.56, 120.69, 120.81, 189.053, 189.069, 190.006, 190.007, 190.008, 190.011, 190.033, 190.035, 218.33, 218.391, 255.05, 255.0518, 255.0525, 255.20, 286.0105, 286.011, 286.012, 286.0113, 286.0114, 287.017, 287.055, and 287.084, Florida Statutes.

A statement of estimated regulatory costs, as defined in Section 120.541(2), Florida Statutes, has not been prepared relative to the Proposed Rule. Any person who wishes to provide the District with a proposal for a lower cost regulatory alternative as provided by Section 120.541(1), Florida Statutes, must do so in writing within twenty-one (21) days after publication of this notice to the District Manager's Office.

For more information regarding the public hearing, the Proposed Rule, or for a copy of the Proposed Rule and the related incorporated documents, if any, please contact the District Manager c/o Wrathell, Hunt and Associates, LLC, 2300 Glades Road, Suite 410W, Boca Raton, Florida 33431, Phone (561) 571-0010, [kantarzhia@whhassociates.com](mailto:kantarzhia@whhassociates.com) (the "District Manager's Office").

This public hearing may be continued to a date, time, and place to be specified on the record at the hearing without additional notice. If anyone chooses to appeal any decision of the Board with respect to any matter considered at the public hearing, such person will need a record of the proceedings and should accordingly ensure that a verbatim record of the proceedings is made which includes the testimony and evidence upon which such appeal is to be based. At the public hearing, staff or Supervisors may participate in the public hearing by speaker telephone.

Pursuant to the provisions of the Americans with Disabilities Act, any person requiring special accommodations at this public hearing because of a disability or physical impairment should contact the District Manager's Office at least forty-eight (48) hours prior to the public hearing. If you are hearing or speech impaired, please contact the Florida Relay Service at 1-800-955-8771 or 1-800-955-8770 for aid in contacting the District Manager's Office.

District Manager  
Westwood of Pasco Community Development District  
June 26, 2026 26-01464P

FIRST INSERTION

**Notice Under Fictitious Name Law Pursuant to Section 865.09, Florida Statutes**

NOTICE IS HEREBY GIVEN that the undersigned, desiring to engage in business under the fictitious name of Pat Learning and Literacy Services located at 4033 Huntingdale Court in the City of Wesley Chapel, Pasco, FL 33543 intends to register the said name with the Division of Corporations of the Department of State, Tallahassee, Florida.

Dated this 19th day of June, 2026  
Glenna Williams  
June 26, 2026 26-01450P

FIRST INSERTION

**Notice Under Fictitious Name Law Pursuant to Section 865.09, Florida Statutes**

NOTICE IS HEREBY GIVEN that the undersigned, desiring to engage in business under the fictitious name of Love Motorsports Port Richey located at 7010-7020 Ridge Road in the City of Port Richey, Pasco, FL 34668 intends to register the said name with the Division of Corporations of the Department of State, Tallahassee, Florida.

Dated this 18th day of June, 2026  
Love Motorsports, Inc.  
June 26, 2026 26-01449P

FIRST INSERTION

**Notice of Public Hearing and Board of Supervisors Meeting of the SageBrush Community Development District**

The Board of Supervisors (the "Board") of the SageBrush Community Development District (the "District") will hold a public hearing and regular meeting on Tuesday, July 14, 2026, at 9:00 a.m. at the Hilton Garden Inn Tampa Suncoast Parkway located at 2155 Northpointe Parkway, Lutz, Florida 33558.

The purpose of the public hearing is to receive public comments on the proposed adoption of the District's fiscal year 2026-2027 proposed budget. A meeting of the Board will also be held where the Board may consider any other business that may properly come before it. A copy of the proposed budget and the agenda may be viewed on the District's website at <https://www.sagebrushcdd.org/> at least two days before the meeting or may be obtained by contacting the District Manager's office via email at [sbrizendine@rizzetta.com](mailto:sbrizendine@rizzetta.com) or via phone at (813) 933-5571.

The public hearing and meeting are open to the public and will be conducted in accordance with the provisions of Florida law for community development districts. They may be continued to a date, time, and place to be specified on the record at the hearing or meeting. There may be occasions when staff or Board members may participate by speaker telephone.

In accordance with the provisions of the Americans with Disabilities Act, any person requiring special accommodations because of a disability or physical impairment should contact the District Manager's office at least 48 hours prior to the meeting. If you are hearing or speech impaired, please contact the Florida Relay Service at 711 or 1-800-955-8771 (TTY), or 1-800-955-8770 (voice) for aid in contacting the District Manager's office.

Each person who decides to appeal any decision made by the Board with respect to any matter considered at the public hearing or meeting is advised that person will need a record of proceedings and that accordingly, the person may need to ensure that a verbatim record of the proceedings is made, including the testimony and evidence upon which such appeal is to be based.

Scott Brizendine  
District Manager  
June 26, 2026 26-01457P

FIRST INSERTION

**Notice of Public Hearing and Board of Supervisors Meeting of the Acacia Fields Community Development District**

The Board of Supervisors (the "Board") of the Acacia Fields Community Development District (the "District") will hold a public hearing and regular meeting on Tuesday, July 14, 2026, at 9:00 a.m. at the Hilton Garden Inn Tampa Suncoast Parkway located at 2155 Northpointe Parkway, Lutz, Florida 33558.

The purpose of the public hearing is to receive public comments on the proposed adoption of the District's fiscal year 2026-2027 proposed budget. A meeting of the Board will also be held where the Board may consider any other business that may properly come before it. A copy of the proposed budget and the agenda may be viewed on the District's website at <https://www.acaciafieldscdd.org/> at least two days before the meeting or may be obtained by contacting the District Manager's office via email at [sbrizendine@rizzetta.com](mailto:sbrizendine@rizzetta.com) or via phone at (813) 933-5571.

The public hearing and meeting are open to the public and will be conducted in accordance with the provisions of Florida law for community development districts. They may be continued to a date, time, and place to be specified on the record at the hearing or meeting. There may be occasions when staff or Board members may participate by speaker telephone.

In accordance with the provisions of the Americans with Disabilities Act, any person requiring special accommodations because of a disability or physical impairment should contact the District Manager's office at least 48 hours prior to the meeting. If you are hearing or speech impaired, please contact the Florida Relay Service at 711 or 1-800-955-8771 (TTY), or 1-800-955-8770 (voice) for aid in contacting the District Manager's office.

Each person who decides to appeal any decision made by the Board with respect to any matter considered at the public hearing or meeting is advised that person will need a record of proceedings and that accordingly, the person may need to ensure that a verbatim record of the proceedings is made, including the testimony and evidence upon which such appeal is to be based.

Scott Brizendine  
District Manager  
June 26, 2026 26-01452P

FIRST INSERTION

**MIRADA COMMUNITY DEVELOPMENT DISTRICT**

**NOTICE OF PUBLIC HEARING TO CONSIDER THE ADOPTION OF THE FISCAL YEAR 2027 PROPOSED BUDGET(S); AND NOTICE OF REGULAR BOARD OF SUPERVISORS' MEETING.**

The Board of Supervisors ("Board") of the Mirada Community Development District ("District") will hold a public hearing and regular meeting as follows:

DATE: 08/04/2026  
TIME: 6:00 PM  
LOCATION: Watergrass II Clubhouse  
32711 Windlestraw Drive  
Wesley Chapel, FL 33545

The purpose of the public hearing is to receive comments and objections on the adoption of the District's proposed budget(s) for the fiscal year beginning October 1, 2026, and ending September 30, 2027 ("Proposed Budget"). A regular Board meeting of the District will also be held at the above time where the Board may consider any other business that may properly come before it. A copy of the agenda and Proposed Budget may be obtained at the offices of the District Manager, Governmental Management Services, 4530 Eagle Falls Place, Tampa, Florida 33619 ("District Manager's Office"), during normal business hours, or by visiting the District's website at <https://www.miradacdd.org/>.

The public hearing and meeting are open to the public and will be conducted in accordance with the provisions of Florida law. The public hearing and/or meeting may be continued in progress to a date, time certain, and place to be specified on the record at the public hearing and/or meeting. There may be occasions when Board Supervisors or District Staff may participate by speaker telephone.

Any person requiring special accommodations at the public hearing or meeting because of a disability or physical impairment should contact the District Manager's Office at least forty-eight (48) hours prior to the public hearing and meeting. If you are hearing or speech impaired, please contact the Florida Relay Service by dialing 7-1-1, or 1-800-955-8771 (TTY) / 1-800-955-8770 (Voice), for aid in contacting the District Manager's Office.

Each person who decides to appeal any decision made by the Board with respect to any matter considered at the public hearing or meeting is advised that person will need a record of proceedings and that accordingly, the person may need to ensure that a verbatim record of the proceedings is made, including the testimony and evidence upon which such appeal is to be based.

Jason Greenwood  
District Manager  
June 26, 2026 26-01455P

FIRST INSERTION

**Notice of Public Workshop Seven Oaks Community Development District**

The Seven Oaks Community Development District will hold a workshop with the SOPOA on July 9, 2026 at 6:00 p.m. at the Seven Oaks Clubhouse, located at 2940 Sports Core Circle, Wesley Chapel, FL 33544.

A copy of the agenda may be obtained by contacting the District Manager's office via phone at (813) 994-1001. The meeting is open to the public and will be conducted in accordance with provisions of Florida Law for Community Development Districts. This meeting may be continued to a date, time, and place to be specified on the record at the meeting. There may be occasions when one or more Supervisors or staff will participate by telephone.

Pursuant to provisions of the Americans with Disabilities Act, any person requiring special accommodations to participate in these meetings is asked to advise the District Office at (813) 994-1001, at least 48 hours before the meetings. If you are hearing or speech impaired, please contact the Florida Relay Service at 1 (800) 955-8770, who can aid you in contacting the District Office.

A person who decides to appeal any decision made by the Board with respect to any matter considered at the meeting is advised that this same person will need a record of the proceedings and that accordingly, the person may need to ensure that a verbatim record of the proceedings is made, including the testimony and evidence upon which such appeal is to be based.

Lisa Castoria  
District Manager  
June 26, 2026 26-01480P

FIRST INSERTION

**NOTICE OF RULE DEVELOPMENT BY THE TOWNS AT WOODSDALE COMMUNITY DEVELOPMENT DISTRICT**

In accordance with Chapters 120 and 190, Florida Statutes, the Towns at Woodsdale Community Development District ("District") hereby gives notice of its intention to develop revised Rules of Procedure to govern the operations of the District. The proposed rule number is ROP-2026-1.

The revised Rules of Procedure will address such areas as the Board of Supervisors, officers and voting, district offices, public information and inspection of records, policies, public meetings, hearings and workshops, rulemaking proceedings, competitive purchase including procedure under the Consultants' Competitive Negotiation Act, procedure regarding auditor selection, purchase of insurance, pre-qualification, construction contracts, goods, supplies and materials, maintenance services, contractual services and protests with respect to proceedings, as well as any other area of the general operation of the District.

The purpose and effect of the revised Rules of Procedure is to provide for efficient and effective District operations and to ensure compliance with recent changes to Florida law. The specific grant of rulemaking authority for the adoption of the proposed revised Rules of Procedure includes Sections 190.011(5), 190.011(15) and 190.035, Florida Statutes. The specific laws implemented in the proposed revised Rules of Procedure include, but are not limited to, Sections 112.08, 112.3143, 112.31446, 112.3145, 119.07, 119.0701, 120.54, 120.542, 120.5435, 120.56, 120.69, 120.81, 189.053, 189.069, 190.006, 190.007, 190.008, 190.011, 190.033, 190.035, 218.33, 218.391, 255.05, 255.0518, 255.0525, 255.20, 286.0105, 286.011, 286.012, 286.0113, 286.0114, 287.017, 287.055, and 287.084, Florida Statutes.

A copy of the proposed revised Rules of Procedure and the related incorporated documents, if any, may be obtained by contacting the District Manager, c/o Wrathell, Hunt and Associates, LLC, 2300 Glades Road, Suite 410W, Boca Raton, Florida 33431, Phone (561) 571-0010.

District Manager  
Towns at Woodsdale Community Development District  
June 26, 2026 26-01463P

FIRST INSERTION

**Notice of Public Hearing and Board of Supervisors Meeting of the West Hillcrest Community Development District**

The Board of Supervisors (the "Board") of the West Hillcrest Community Development District (the "District") will hold a public hearing and regular meeting on Tuesday, July 21, 2026, at 10:45 a.m. at the SpringHill Suites by Marriott Tampa Suncoast Parkway located at 16615 Crosspointe Run, Land O'Lakes, Florida 34638.

The purpose of the public hearing is to receive public comments on the proposed adoption of the District's fiscal year 2026-2027 proposed budget. A meeting of the Board will also be held where the Board may consider any other business that may properly come before it. A copy of the proposed budget and the agenda may be viewed on the District's website at <https://www.westhillcrestcdd.com/> at least two days before the meeting or may be obtained by contacting the District Manager's office via email at [deborah.wallace@inframark.com](mailto:deborah.wallace@inframark.com) or via phone at 813-873-7300.

The public hearing and meeting are open to the public and will be conducted in accordance with the provisions of Florida law for community development districts. They may be continued to a date, time, and place to be specified on the record at the hearing or meeting. There may be occasions when staff or Board members may participate by speaker telephone.

In accordance with the provisions of the Americans with Disabilities Act, any person requiring special accommodations because of a disability or physical impairment should contact the District Manager's office at least 48 hours prior to the meeting. If you are hearing or speech impaired, please contact the Florida Relay Service at 711 or 1-800-955-8771 (TTY), or 1-800-955-8770 (voice) for aid in contacting the District Manager's office.

Each person who decides to appeal any decision made by the Board with respect to any matter considered at the public hearing or meeting is advised that person will need a record of proceedings and that accordingly, the person may need to ensure that a verbatim record of the proceedings is made, including the testimony and evidence upon which such appeal is to be based.

Deborah Wallace  
District Manager  
June 26, 2026 26-01458P

FIRST INSERTION

**NOTICE OF RULE DEVELOPMENT BY THE RIVERWOOD ESTATES COMMUNITY DEVELOPMENT DISTRICT**

In accordance with Chapters 120 and 190, Florida Statutes, the Riverwood Estates Community Development District ("District") hereby gives notice of its intention to develop revised Rules of Procedure to govern the operations of the District. The proposed rule number is ROP-2026-1.

The revised Rules of Procedure will address such areas as the Board of Supervisors, officers and voting, district offices, public information and inspection of records, policies, public meetings, hearings and workshops, rulemaking proceedings, competitive purchase including procedure under the Consultants' Competitive Negotiation Act, procedure regarding auditor selection, purchase of insurance, pre-qualification, construction contracts, goods, supplies and materials, maintenance services, contractual services and protests with respect to proceedings, as well as any other area of the general operation of the District.

The purpose and effect of the revised Rules of Procedure is to provide for efficient and effective District operations and to ensure compliance with recent changes to Florida law. The specific grant of rulemaking authority for the adoption of the proposed revised Rules of Procedure includes Sections 190.011(5), 190.011(15) and 190.035, Florida Statutes. The specific laws implemented in the proposed revised Rules of Procedure include, but are not limited to, Sections 112.08, 112.3143, 112.31446, 112.3145, 119.07, 119.0701, 120.54, 120.542, 120.5435, 120.56, 120.69, 120.81, 189.053, 189.069, 190.006, 190.007, 190.008, 190.011, 190.033, 190.035, 218.33, 218.391, 255.05, 255.0518, 255.0525, 255.20, 286.0105, 286.011, 286.012, 286.0113, 286.0114, 287.017, 287.055, and 287.084, Florida Statutes.

A copy of the proposed revised Rules of Procedure and the related incorporated documents, if any, may be obtained by contacting the District Manager, c/o Wrathell, Hunt & Associates, LLC, 2300 Glades Road, Suite 410W, Boca Raton, Florida 33431, (561) 571-0010 [suitk@whhassociates.com](mailto:suitk@whhassociates.com) (the "District Manager's Office").

Kristen Suit, District Manager  
Riverwood Estates Community Development District  
June 26, 2026 26-01474P

## --- PUBLIC NOTICES / ESTATE ---

## FIRST INSERTION

## SILVERADO COMMUNITY DEVELOPMENT DISTRICT

**NOTICE OF PUBLIC HEARING TO CONSIDER THE ADOPTION OF THE FISCAL YEAR 2027 BUDGET; NOTICE OF PUBLIC HEARING TO CONSIDER THE IMPOSITION OF OPERATIONS AND MAINTENANCE SPECIAL ASSESSMENTS, ADOPTION OF AN ASSESSMENT ROLL, AND THE LEVY, COLLECTION, AND ENFORCEMENT OF THE SAME; AND NOTICE OF REGULAR BOARD OF SUPERVISORS' MEETING.**

## Upcoming Public Hearings and Regular Meeting

The Board of Supervisors ("Board") for the Silverado Community Development District ("District") will hold two (2) public hearings and a regular meeting at the following date, time, and location:

DATE:  
July 20, 2026  
TIME:  
5:00 p.m.  
LOCATION:  
Alice Hall  
38116 5th Avenue  
Zephyrhills, Florida 33542

The first public hearing is being held pursuant to Chapter 190, Florida Statutes, to receive public comment and objections on the District's proposed budget ("Proposed Budget") for the Fiscal Year beginning October 1, 2026, and ending September 30, 2027 ("Fiscal Year 2027"). The second public hearing is being held pursuant to Chapters 190, 197, Florida Statutes, to consider the imposition of operations and maintenance special assessments ("O&M Assessments") upon the lands located within the District, to fund the Proposed Budget for Fiscal Year 2027; to consider the adoption of an assessment roll; and, to provide for the levy, collection, and enforcement of assessments. At the conclusion of the hearings, the Board will, by resolution, adopt a budget and levy O&M Assessments as finally approved by the Board. A Board meeting of the District will also be held where the Board may consider any other District business.

## Description of Assessments

The District imposes O&M Assessments on benefitted property within the District for the purpose of funding the District's general administrative, operations, and maintenance budget. A geographic depiction of the property potentially subject to the proposed O&M Assessments is identified in the map attached hereto. The table below shows the schedule of the proposed O&M Assessments, which are subject to change at the hearing:

Lot Type	Total # of Units	ERU Factor	Current Annual O&M Assessment (October 1, 2025-September 30, 2026)	Proposed Annual O&M Assessment (October 1, 2026-September 30, 2027)*	Change in Annual Dollar Amount
SF 50'	145	1.00	\$2,242.80	\$2,408.55	\$165.75
SF 55'	96	1.10	\$2,467.08	\$2,649.40	\$182.32
SF 60'/65'	189	1.18	\$2,646.50	\$2,842.09	\$195.59

\* Including collection costs and early payment discounts

The proposed O&M Assessments as stated include collection costs and/or early payment discounts, which Pasco County ("County") may impose on assessments that are collected on the County tax bill. Moreover, pursuant to Section 197.3632(4), Florida Statutes, the lien amount shall serve as the "maximum rate" authorized by law for O&M Assessments, such that no assessment hearing shall be held or notice provided in future years unless the assessments are proposed to be increased or another criterion within Section 197.3632(4), Florida Statutes, is met. Note that the O&M Assessments do not include any debt service assessments previously levied by the District that are due to be collected for Fiscal Year 2027.

For Fiscal Year 2027, the District intends to have the County tax collector collect the assessments imposed on certain developed property. It is important to pay your assessment because failure to pay will cause a tax certificate to be issued against the property which may result in loss of title, or for direct billed assessments, may result in a foreclosure action, which also may result in a loss of title. The District's decision to collect assessments on the tax roll or by direct billing does not preclude the District from later electing to collect those or other assessments in a different manner at a future time.

## Additional Provisions

The public hearings and meeting are open to the public and will be conducted in accordance with the provisions of Florida law. A copy of the Proposed Budget, proposed assessment roll, and the agenda for the hearings and meeting may be obtained at the offices of the District Manager, located at 2300 Glades Road, Suite 410W, Boca Raton, Florida 33431, Ph: (877) 276-0889 ("District Manager's Office"), during normal business hours. The public hearings and meeting may be continued to a date, time, and place to be specified on the record at the hearings or meeting. There may be occasions when staff or board members may participate by speaker telephone.

Any person requiring special accommodations at this meeting because of a disability or physical impairment should contact the District Manager's Office at least three (3) business days prior to the meeting. If you are hearing or speech impaired, please contact the Florida Relay Service by dialing 7-1-1, or 1-800-955-8771 (TTY) / 1-800-955-8770 (Voice), for aid in contacting the District Manager's Office.

Please note that all affected property owners have the right to appear at the public hearings and meeting and may also file written objections with the District Manager's Office within twenty (20) days of publication of this notice. Each person who decides to appeal any decision made by the Board with respect to any matter considered at the public hearings or meeting is advised that person will need a record of proceedings and that accordingly, the person may need to ensure that a verbatim record of the proceedings is made, including the testimony and evidence upon which such appeal is to be based.

District Manager



June 26; July 3, 2026

26-01462P

## FIRST INSERTION

**NOTICE TO CREDITORS IN THE CIRCUIT COURT FOR PASCO COUNTY, FLORIDA PROBATE DIVISION**  
**File No.:**  
**51-2026-CP-000920-WS**  
**IN RE: ESTATE OF DEBORAH A. VOLPATTI a/k/a DEBORAH ANN VOLPATTI a/k/a DEBORAH VOLPATTI Deceased.**

The administration of the estate of Deborah A. Volpatti a/k/a Deborah Ann Volpatti a/k/a Deborah Volpatti, deceased, whose date of death was March 28, 2026, is pending in the Circuit Court for Pasco County, Florida, Probate Division, the address of which is 7530 Little Road, New Port Richey, Florida 34654. The names and addresses of the personal representative and the personal representative's attorney are set forth below.

All creditors of the decedent and other persons having claims or demands against decedent's estate on whom a copy of this notice is required to be served must file their claims with this court ON OR BEFORE THE LATER OF 3 MONTHS AFTER THE TIME OF THE FIRST PUBLICATION OF THIS NOTICE OR 30 DAYS AFTER THE DATE OF SERVICE OF A COPY OF THIS NOTICE ON THEM.

All other creditors of the decedent and other persons having claims or demands against decedent's estate must file their claims with this court WITHIN 3 MONTHS AFTER THE DATE OF THE FIRST PUBLICATION OF THIS NOTICE.

The personal representative has no

duty to discover whether any property held at the time of the decedent's death by the decedent or the decedent's surviving spouse is property to which the Florida Uniform Disposition of Community Property Rights at Death Act as described in ss. 732.216-732.228, Florida Statutes, applies, or may apply, unless a written demand is made by a creditor as specified under s. 732.2211, Florida Statutes. The written demand must be filed with the clerk.

**ALL CLAIMS NOT FILED WITHIN THE TIME PERIODS SET FORTH IN FLORIDA STATUTES SECTION 733.702 WILL BE FOREVER BARRED.**

**NOTWITHSTANDING THE TIME PERIODS SET FORTH ABOVE, ANY CLAIM FILED TWO (2) YEARS OR MORE AFTER THE DECEDENT'S DATE OF DEATH IS BARRED.**

The date of first publication of this notice is June 26, 2026.

## Personal Representative:

**Cynthia A. Grant**  
4664 Arboretum Circle, Unit 103  
Naples, Florida 34112

Attorney for Personal Representative:  
Ryan A. Doddridge, Esq.  
Attorney  
Florida Bar Number: 74728  
STEARNS, WILLIAMS & DODDRIDGE, PA  
6337 Grand Boulevard  
New Port Richey, Florida 34652  
Telephone: (727) 846-8500  
Fax: (727) 848-2814  
E-Mail:  
ryan@flprobatetrustlaw.com  
Secondary E-Mail:  
stacey@flprobatetrustlaw.com  
June 26; July 3, 2026 26-01447P

## FIRST INSERTION

**NOTICE TO CREDITORS IN THE CIRCUIT COURT FOR PASCO COUNTY, FLORIDA PROBATE DIVISION**  
**File No. 2026-CP-879**  
**IN RE: ESTATE OF GEORGE E. FERRITER AKA GEORGE EDMOND FERRITER Deceased.**

The administration of the estate of GEORGE E. FERRITER AKA GEORGE EDMOND FERRITER, deceased, whose date of death was March 14, 2026, is pending in the Circuit Court for Pasco County, Florida, Probate Division, the address of which is P.O. Drawer 338, New Port Richey, FL 34656-0338. The names and addresses of the personal representative and the personal representative's attorney are set forth below.

All creditors of the decedent and other persons having claims or demands against decedent's estate on whom a copy of this notice is required to be served must file their claims with this court ON OR BEFORE THE LATER OF 3 MONTHS AFTER THE TIME OF THE FIRST PUBLICATION OF THIS NOTICE OR 30 DAYS AFTER THE DATE OF SERVICE OF A COPY OF THIS NOTICE ON THEM.

All other creditors of the decedent and other persons having claims or demands against decedent's estate must file their claims with this court WITHIN 3 MONTHS AFTER THE DATE OF THE FIRST PUBLICATION OF THIS NOTICE.

The personal representative has no

duty to discover whether any property held at the time of the decedent's death by the decedent or the decedent's surviving spouse is property to which the Florida Uniform Disposition of Community Property Rights at Death Act as described in ss. 732.216-732.228, Florida Statutes, applies, or may apply, unless a written demand is made by a creditor as specified under s. 732.2211, Florida Statutes. The written demand must be filed with the clerk.

**ALL CLAIMS NOT FILED WITHIN THE TIME PERIODS SET FORTH IN FLORIDA STATUTES SECTION 733.702 WILL BE FOREVER BARRED.**

**NOTWITHSTANDING THE TIME PERIODS SET FORTH ABOVE, ANY CLAIM FILED TWO (2) YEARS OR MORE AFTER THE DECEDENT'S DATE OF DEATH IS BARRED.**

The date of first publication of this notice is June 26, 2026.

## Personal Representative:

**ANGELA GREENBERG**  
48 Hamilton Avenue  
Elgin, Illinois 60123  
Attorney for Personal Representative:  
STEPHEN R. WILLIAMS, Attorney  
Florida Bar Number: 748188  
WILLIAMS & ACKLEY PLC  
10820 State Road 54, Suite 202  
TRINITY, FL 34655  
Telephone: (727) 842-9758  
Fax: (727) 848-2494  
E-Mail: cyndi@wrplawyers.com  
Secondary E-Mail:  
srs@wrplawyers.com  
June 26; July 3, 2026 26-01470P

## FIRST INSERTION

## KD52 COMMUNITY DEVELOPMENT DISTRICT NO. 1

**NOTICE OF PUBLIC HEARING TO CONSIDER THE ADOPTION OF THE FY 2027 BUDGET; NOTICE OF PUBLIC HEARING TO CONSIDER THE IMPOSITION OF OPERATIONS AND MAINTENANCE SPECIAL ASSESSMENTS, ADOPTION OF AN ASSESSMENT ROLL, AND THE LEVY, COLLECTION, AND ENFORCEMENT OF THE SAME; AND NOTICE OF REGULAR BOARD OF SUPERVISORS' MEETING.**

The Board of Supervisors ("Board") for the KD52 Community Development District No. 1 ("District") will hold the following public hearings and regular meeting:

DATE: July 21, 2026  
TIME: 1:00 PM  
LOCATION: RAW Space Collaborative  
6013 Wesley Grove Blvd.  
Building 2, Suite 208  
Wesley Chapel, Florida 33544

The first public hearing is being held pursuant to Chapter 190, Florida Statutes, to receive public comment and objections on the District's proposed budget ("Proposed Budget") for the fiscal year beginning October 1, 2026, and ending September 30, 2027 ("FY 2027"). The second public hearing is being held pursuant to Chapters 190, Florida Statutes, to consider the imposition of operations and maintenance special assessments ("O&M Assessments") upon the lands located within the District to fund the Proposed Budget for FY 2027; to consider the adoption of an assessment roll; and to provide for the levy, collection, and enforcement of O&M Assessments. At the conclusion of the public hearings, the Board will, by resolution, adopt a budget and levy O&M Assessments as finally approved by the Board. A regular Board meeting of the District will also be held where the Board may consider any other District business that may properly come before it.

## Description of Assessments

The District imposes O&M Assessments on benefitted property within the District for the purpose of funding the District's general administrative, operations, and maintenance budget. A description of the services to be funded by the O&M Assessments, and the properties to be improved and benefitted from the O&M Assessments, are all set forth in the Proposed Budget. A geographic depiction of the property potentially subject to the proposed O&M Assessments is identified in the map attached hereto. The table below shows the schedule of the proposed O&M Assessments, which are subject to change at the hearing:

Land Use	Total Units/1,000 Sq. Ft.	EAU/ERU Factor	Proposed Annual Assessment*	O&M
TH	230	0.60	\$281.04	
MF	680	0.40	\$187.36	
SF 50'	226	0.75	\$351.30	
SF 70'	333	1.00	\$468.40	
Commercial	20	0.75	\$351.30	

\*includes collection costs and early payment discounts

**NOTE: THE DISTRICT RESERVES ALL RIGHTS TO CHANGE THE LAND USES, NUMBER OF UNITS, EQUIVALENT ASSESSMENT OR RESIDENTIAL UNIT ("EAU/ERU") FACTORS, AND O&M ASSESSMENT AMOUNTS AT THE PUBLIC HEARING, WITHOUT FURTHER NOTICE.**

The proposed O&M Assessments as stated include collection costs and/or early payment discounts imposed on assessments collected by the Pasco County ("County") Tax Collector on the tax bill. Moreover, pursuant to Section 197.3632(4), Florida Statutes, the lien amount shall serve as the "maximum rate" authorized by law for O&M Assessments, such that no public hearing on O&M Assessments shall be held or notice provided in future years unless the O&M Assessments are proposed to be increased or another criterion within Section 197.3632(4), Florida Statutes, is met. Note, the O&M Assessments do not include debt service assessments previously levied by the District, if any.

For FY 2027, the District intends to have the County Tax Collector collect the O&M Assessments imposed on certain developed property and will directly collect the O&M Assessments on the remaining benefitted property, if any, by sending out a bill at least thirty (30) days prior to the first Assessment due date. It is important to pay your O&M Assessment because failure to pay will cause a tax certificate to be issued against the property which may result in loss of title or, for direct billed O&M Assessments, may result in a foreclosure action which also may result in a loss of title. The District's decision to collect O&M Assessments on the County tax roll or by direct billing does not preclude the District from later electing to collect those or other assessments in a different manner at a future time.

## Additional Provisions

The public hearings and meeting are open to the public and will be conducted in accordance with the provisions of Florida law. A copy of the Proposed Budget, proposed assessment roll, and the agenda for the public hearings and meeting may be obtained at the offices of the District Manager, Wrathell, Hunt and Associates, LLC, 2300 Glades Road, Suite 410W, Boca Raton, Florida 33431, (561) 571-0100 ("District Manager's Office"), during normal business hours, or by visiting the District's website at <https://ormondcrossingwestcdd.net>. The public hearings and meeting may be continued in progress to a date, time certain, and place to be specified on the record at the public hearings or meeting. There may be occasions when staff or board members may participate by speaker telephone.

Any person requiring special accommodations at the public hearings or meeting because of a disability or physical impairment should contact the District Manager's Office at least forty-eight (48) hours prior to the public hearings and meeting. If you are hearing or speech impaired, please contact the Florida Relay Service by dialing 7-1-1, or 1-800-955-8771 (TTY) / 1-800-955-8770 (Voice), for aid in contacting the District Manager's Office.

Please note that all affected property owners have the right to appear at the public hearings and meeting and may also file written objections with the District Manager's Office within twenty days of publication of this notice. Each person who decides to appeal any decision made by the Board with respect to any matter considered at the public hearings or meeting is advised that person will need a record of proceedings and that, accordingly, the person may need to ensure that a verbatim record of the proceedings is made, including the testimony and evidence upon which such appeal is to be based.

District Manager

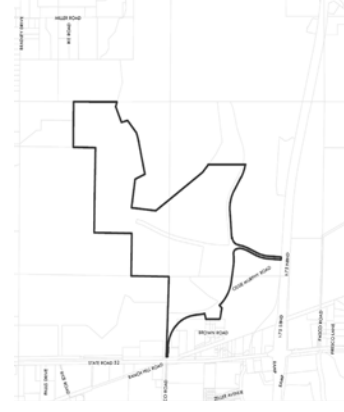

June 26, 2026

26-01471P

## FIRST INSERTION

**NOTICE TO CREDITORS IN THE CIRCUIT COURT FOR PASCO COUNTY, FLORIDA PROBATE DIVISION**  
**File No.**  
**2025CP002100CPAXWS**  
**IN RE: ESTATE OF MELISSA DAWN STIEBER Deceased.**

The administration of the estate of MELISSA DAWN STIEBER, deceased, whose date of death was September 8, 2025, is pending in the Circuit Court for Pasco County, Florida, Probate Division, the address of which is P. O. Drawer 338, New Port Richey, Florida 34656-0338. The names and addresses of the personal representative and the personal representative's attorney are set forth below.

All creditors of the decedent and other persons having claims or demands against decedent's estate on whom a copy of this notice is required to be served must file their claims with this court ON OR BEFORE THE LATER OF 3 MONTHS AFTER THE TIME OF THE FIRST PUBLICATION OF THIS NOTICE OR 30 DAYS AFTER THE DATE OF SERVICE OF A COPY OF THIS NOTICE ON THEM.

The personal representative has no duty to discover whether any property held at the time of the decedent's death by the decedent or the decedent's surviving spouse is property to which the Florida Uniform Disposition of Community Property Rights at Death Act as described in ss. 732.216-732.228,

Florida Statutes, applies, or may apply, unless a written demand is made by a creditor as specified under s. 732.2211, Florida Statutes.

**All other creditors of the decedent and other persons having claims or demands against decedent's estate must file their claims with this court WITHIN 3 MONTHS AFTER THE DATE OF THE FIRST PUBLICATION OF THIS NOTICE.**

**ALL CLAIMS NOT FILED WITHIN THE TIME PERIODS SET FORTH IN FLORIDA STATUTES SECTION 733.702 WILL BE FOREVER BARRED.**

**NOTWITHSTANDING THE TIME PERIODS SET FORTH ABOVE, ANY CLAIM FILED TWO (2) YEARS OR MORE AFTER THE DECEDENT'S DATE OF DEATH IS BARRED.**

The date of first publication of this notice is June 26, 2026.

## Personal Representative:

**/s/ Aidan T. Cameron**  
**Aidan T. Cameron**  
2626 Gailwood Drive  
New Port Richey, FL 34655  
Attorney for Personal Representative:  
/s/ Zachary Ryan Walters  
Zachary Ryan Walters, Esq.  
Florida Bar Number: 1059075  
WOLLINKA & WOLLINKA,  
ATTORNEYS AT LAW  
10015 Trinity Blvd., Suite 101  
Trinity, FL 34655  
Telephone: (727) 937-4177  
E-Mail: Zack@wollinka.com  
June 26; July 3, 2026 26-01467P

--- PUBLIC NOTICES / ESTATE ---

FIRST INSERTION

EPPERSON RANCH COMMUNITY DEVELOPMENT DISTRICT

**NOTICE OF PUBLIC HEARING TO CONSIDER THE ADOPTION OF THE FY 2027 BUDGET; NOTICE OF PUBLIC HEARING TO CONSIDER THE IMPOSITION OF OPERATIONS AND MAINTENANCE SPECIAL ASSESSMENTS, ADOPTION OF AN ASSESSMENT ROLL, AND THE LEVY, COLLECTION, AND ENFORCEMENT OF THE SAME; AND NOTICE OF REGULAR BOARD OF SUPERVISORS' MEETING.**

The Board of Supervisors ("Board") for the Epperson Ranch Community Development District ("District") will hold the following public hearings and regular meeting:

DATE: August 3, 2026  
 TIME: 6:15 PM  
 LOCATION: WaterGrass Club  
 32711 Windelstraw Drive  
 Wesley Chapel, Florida 33545

The first public hearing is being held pursuant to Chapter 190, Florida Statutes, to receive public comment and objections on the District's proposed budget ("Proposed Budget") for the fiscal year beginning October 1, 2026, and ending September 30, 2027 ("FY 2027"). The second public hearing is being held pursuant to Chapters 190, Florida Statutes, to consider the imposition of operations and maintenance special assessments ("O&M Assessments") upon the lands located within the District to fund the Proposed Budget for FY 2027; to consider the adoption of an assessment roll; and to provide for the levy, collection, and enforcement of O&M Assessments. At the conclusion of the public hearings, the Board will, by resolution, adopt a budget and levy O&M Assessments as finally approved by the Board. A regular Board meeting of the District will also be held where the Board may consider any other District business that may properly come before it.

**Description of Assessments**

The District imposes O&M Assessments on benefitted property within the District for the purpose of funding the District's general administrative, operations, and maintenance budget. A description of the services to be funded by the O&M Assessments, and the properties to be improved and benefitted from the O&M Assessments, are all set forth in the Proposed Budget. A geographic depiction of the property potentially subject to the proposed O&M Assessments is identified in the map attached hereto. The table below shows the schedule of the proposed O&M Assessments, which are subject to change at the hearing:

Land Use	Total # of Units	ERU Factor	Proposed O&M Assessment
SINGLE FAMILY 40-49'	249	0.82	\$1,587.21
SINGLE FAMILY 50-59'	430	1.00	\$1,935.62
SINGLE FAMILY 60-69'	232	1.18	\$2,284.03
SINGLE FAMILY 75'	52	1.36	\$2,632.44

\*includes collection costs and early payment discounts

**NOTE: THE DISTRICT RESERVES ALL RIGHTS TO CHANGE THE LAND USES, NUMBER OF UNITS, EQUIVALENT ASSESSMENT OR RESIDENTIAL UNIT ("EAU/ERU") FACTORS, AND O&M ASSESSMENT AMOUNTS AT THE PUBLIC HEARING, WITHOUT FURTHER NOTICE.**

The proposed O&M Assessments as stated include collection costs and/or early payment discounts imposed on assessments collected by the Pasco County ("County") Tax Collector on the tax bill. Moreover, pursuant to Section 197.3632(4), Florida Statutes, the lien amount shall serve as the "maximum rate" authorized by law for O&M Assessments, such that no public hearing on O&M Assessments shall be held or notice provided in future years unless the O&M Assessments are proposed to be increased or another criterion within Section 197.3632(4), Florida Statutes, is met. Note, the O&M Assessments do not include debt service assessments previously levied by the District, if any.

For FY 2027, the District intends to have the County Tax Collector collect the O&M Assessments imposed on certain developed property and will directly collect the O&M Assessments on the remaining benefitted property, if any, by sending out a bill at least thirty (30) days prior to the first Assessment due date. It is important to pay your O&M Assessment because failure to pay will cause a tax certificate to be issued against the property which may result in loss of title or, for direct billed O&M Assessments, may result in a foreclosure action which also may result in a loss of title. The District's decision to collect O&M Assessments on the County tax roll or by direct billing does not preclude the District from later electing to collect those or other assessments in a different manner at a future time.

**Additional Provisions**

The public hearings and meeting are open to the public and will be conducted in accordance with the provisions of Florida law. A copy of the Proposed Budget, proposed assessment roll, and the agenda for the public hearings and meeting may be obtained at the offices of the District Manager, Heath Beckett, c/o Vesta District Services, 250 International Parkway, Suite 208, Lake Mary, Florida 32746, (321) 263-0132 ("District Manager's Office"), during normal business hours, or by visiting the District's website at <https://www.eppersonranchcdd.org/>. The public hearings and meeting may be continued in progress to a date, time certain, and place to be specified on the record at the public hearings or meeting. There may be occasions when staff or board members may participate by speaker telephone.

Any person requiring special accommodations at the public hearings or meeting because of a disability or physical impairment should contact the District Manager's Office at least forty-eight (48) hours prior to the public hearings and meeting. If you are hearing or speech impaired, please contact the Florida Relay Service by dialing 7-1-1, or 1-800-955-8771 (TTY) / 1-800-955-8770 (Voice), for aid in contacting the District Manager's Office.

Please note that all affected property owners have the right to appear at the public hearings and meeting and may also file written objections with the District Manager's Office within twenty days of publication of this notice. Each person who decides to appeal any decision made by the Board with respect to any matter considered at the public hearings or meeting is advised that person will need a record of proceedings and that, accordingly, the person may need to ensure that a verbatim record of the proceedings is made, including the testimony and evidence upon which such appeal is to be based.

District Manager

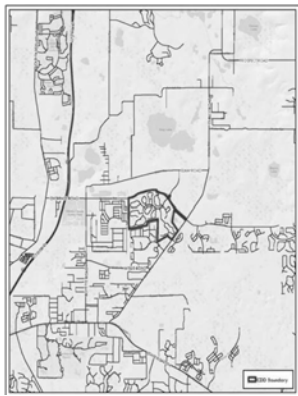

26-01483P

FIRST INSERTION

KD52 COMMUNITY DEVELOPMENT DISTRICT NO. 2

**NOTICE OF PUBLIC HEARING TO CONSIDER THE ADOPTION OF THE FY 2027 BUDGET; NOTICE OF PUBLIC HEARING TO CONSIDER THE IMPOSITION OF OPERATIONS AND MAINTENANCE SPECIAL ASSESSMENTS, ADOPTION OF AN ASSESSMENT ROLL, AND THE LEVY, COLLECTION, AND ENFORCEMENT OF THE SAME; AND NOTICE OF REGULAR BOARD OF SUPERVISORS' MEETING.**

The Board of Supervisors ("Board") for the KD52 Community Development District No. 2 ("District") will hold the following public hearings and regular meeting:

DATE: July 21, 2026  
 TIME: 1:00 PM  
 LOCATION: RAW Space Collaborative  
 6013 Wesley Grove Blvd.  
 Building 2, Suite 208  
 Wesley Chapel, Florida 33544

The first public hearing is being held pursuant to Chapter 190, Florida Statutes, to receive public comment and objections on the District's proposed budget ("Proposed Budget") for the fiscal year beginning October 1, 2026, and ending September 30, 2027 ("FY 2027"). The second public hearing is being held pursuant to Chapters 190, Florida Statutes, to consider the imposition of operations and maintenance special assessments ("O&M Assessments") upon the lands located within the District to fund the Proposed Budget for FY 2027; to consider the adoption of an assessment roll; and to provide for the levy, collection, and enforcement of O&M Assessments. At the conclusion of the public hearings, the Board will, by resolution, adopt a budget and levy O&M Assessments as finally approved by the Board. A regular Board meeting of the District will also be held where the Board may consider any other District business that may properly come before it.

**Description of Assessments**

The District imposes O&M Assessments on benefitted property within the District for the purpose of funding the District's general administrative, operations, and maintenance budget. A description of the services to be funded by the O&M Assessments, and the properties to be improved and benefitted from the O&M Assessments, are all set forth in the Proposed Budget. A geographic depiction of the property potentially subject to the proposed O&M Assessments is identified in the map attached hereto. The table below shows the schedule of the proposed O&M Assessments, which are subject to change at the hearing:

Land Use	Total Units /1,000 Sq. Ft.	EAU/ERU Factor	Proposed Annual Assessment*	O&M
TH	24	0.60	\$329.01	
Commercial/Retail	235	0.75	\$411.26	
Light Industrial	1,900	0.20	\$109.67	

\*includes collection costs and early payment discounts

**NOTE: THE DISTRICT RESERVES ALL RIGHTS TO CHANGE THE LAND USES, NUMBER OF UNITS, EQUIVALENT ASSESSMENT OR RESIDENTIAL UNIT ("EAU/ERU") FACTORS, AND O&M ASSESSMENT AMOUNTS AT THE PUBLIC HEARING, WITHOUT FURTHER NOTICE.**

The proposed O&M Assessments as stated include collection costs and/or early payment discounts imposed on assessments collected by the Pasco County ("County") Tax Collector on the tax bill. Moreover, pursuant to Section 197.3632(4), Florida Statutes, the lien amount shall serve as the "maximum rate" authorized by law for O&M Assessments, such that no public hearing on O&M Assessments shall be held or notice provided in future years unless the O&M Assessments are proposed to be increased or another criterion within Section 197.3632(4), Florida Statutes, is met. Note, the O&M Assessments do not include debt service assessments previously levied by the District, if any.

For FY 2027, the District intends to have the County Tax Collector collect the O&M Assessments imposed on certain developed property and will directly collect the O&M Assessments on the remaining benefitted property, if any, by sending out a bill at least thirty (30) days prior to the first Assessment due date. It is important to pay your O&M Assessment because failure to pay will cause a tax certificate to be issued against the property which may result in loss of title or, for direct billed O&M Assessments, may result in a foreclosure action which also may result in a loss of title. The District's decision to collect O&M Assessments on the County tax roll or by direct billing does not preclude the District from later electing to collect those or other assessments in a different manner at a future time.

**Additional Provisions**

The public hearings and meeting are open to the public and will be conducted in accordance with the provisions of Florida law. A copy of the Proposed Budget, proposed assessment roll, and the agenda for the public hearings and meeting may be obtained at the offices of the District Manager, Wrathell, Hunt and Associates, LLC, 2300 Glades Road, Suite 410W, Boca Raton, Florida 33431, (561) 571-0100 ("District Manager's Office"), during normal business hours, or by visiting the District's website at <https://ormondcrossingswestcdd.net>. The public hearings and meeting may be continued in progress to a date, time certain, and place to be specified on the record at the public hearings or meeting. There may be occasions when staff or board members may participate by speaker telephone.

Any person requiring special accommodations at the public hearings or meeting because of a disability or physical impairment should contact the District Manager's Office at least forty-eight (48) hours prior to the public hearings and meeting. If you are hearing or speech impaired, please contact the Florida Relay Service by dialing 7-1-1, or 1-800-955-8771 (TTY) / 1-800-955-8770 (Voice), for aid in contacting the District Manager's Office.

Please note that all affected property owners have the right to appear at the public hearings and meeting and may also file written objections with the District Manager's Office within twenty days of publication of this notice. Each person who decides to appeal any decision made by the Board with respect to any matter considered at the public hearings or meeting is advised that person will need a record of proceedings and that, accordingly, the person may need to ensure that a verbatim record of the proceedings is made, including the testimony and evidence upon which such appeal is to be based.

District Manager



26-01472P

FIRST INSERTION

**NOTICE TO CREDITORS (Summary Administration) IN THE CIRCUIT COURT FOR PASCO COUNTY, FLORIDA PROBATE DIVISION File No. 51-2026-CP-000964-WS IN RE: ESTATE OF GLENRANALD COLIN MOREY Deceased.**

TO ALL PERSONS HAVING CLAIMS OR DEMANDS AGAINST THE ABOVE ESTATE:

You are hereby notified that an Order of Summary Administration has been entered in the estate of GLENRANALD COLIN MOREY, deceased, File Number 51-2026-CP-000964-WS, by the Circuit Court for PASCO County, Florida, Probate Division, the address of which is 7530 Little Road, New Port Richey, FL 34654; that the decedent's date of death was March 11, 2026; that the total value of the estate is \$4,000.00 and that the names and addresses of those to whom it has been assigned by such order are:

Name Address  
 SYLVIA MOREY  
 PO Box 401  
 Millet, Alberta (Canada) TOC 1ZO  
 ALL INTERESTED PERSONS ARE NOTIFIED THAT:

All creditors of the estate of the decedent and persons having claims or demands against the estate of the decedent other than those for whom provision for full payment was made in the Order of Summary Administration must file their claims with this court WITHIN THE TIME PERIODS SET

FORTH IN FLORIDA STATUTES SECTION 733.702. ALL CLAIMS AND DEMANDS NOT SO FILED WILL BE FOREVER BARRED. NOTWITHSTANDING ANY OTHER APPLICABLE TIME PERIOD, ANY CLAIM FILED TWO (2) YEARS OR MORE AFTER THE DECEDENT'S DATE OF DEATH IS BARRED.

The personal representative has no duty to discover whether any property held at the time of the decedent's death by the decedent or the decedent's surviving spouse is property to which the Florida Uniform Disposition of Community Property Rights at Death Act as described in sections 732.216-732.288 Florida Statutes, applies, or may apply, unless a written demand is made by a creditor as specified under section 732.2211, Florida Statutes. The written demand must be filed with the clerk.

The date of first publication of this Notice is June 26, 2026.

**Person Giving Notice:**  
**JEANNIE BUTTRY**  
 7033 Gulf Breeze Circle  
 Hudson, Florida 34667  
 Attorney for Person Giving Notice  
 DONALD R. PEYTON  
 Attorney  
 Florida Bar Number: 516619  
 7317 Little Road  
 New Port Richey, FL 34654  
 Telephone: (727) 848-5997  
 Fax: (727) 848-4072  
 E-Mail: peytonlaw@yahoo.com  
 Secondary E-Mail: peytonlaw2@gmail.com  
 June 26; July 3, 2026 26-01482P

FIRST INSERTION

**NOTICE TO CREDITORS IN THE CIRCUIT COURT FOR PASCO COUNTY, FLORIDA PROBATE DIVISION File No. 2026-CP-938 IN RE: ESTATE OF MARTIN MANNINA AKA MARTIN ANTHONY MANNINA Deceased.**

The administration of the estate of Martin Mannina aka Martin Anthony Mannina, deceased, whose date of death was May 23, 2026, is pending in the Circuit Court for Pasco County, Florida, Probate Division, the address of which is 7530 Little Road, New Port Richey, FL 34654. The names and addresses of the personal representative and the personal representative's attorney are set forth below.

All creditors of the decedent and other persons having claims or demands against the decedent's estate on whom a copy of this notice is required to be served must file their claims with this court ON OR BEFORE THE LATER OF 3 MONTHS AFTER THE TIME OF THE FIRST PUBLICATION OF THIS NOTICE OR 30 DAYS AFTER THE DATE OF SERVICE OF A COPY OF THIS NOTICE ON THEM.

All other creditors of the decedent and other persons having claims or demands against decedent's estate must file their claims with this court WITHIN 3 MONTHS AFTER THE DATE OF THE FIRST PUBLICATION OF THIS NOTICE.

The personal representative has no

duty to discover whether any property held at the time of the decedent's death by the decedent or the decedent's surviving spouse is property to which the Florida Uniform Disposition of Community Property Rights at Death Act as described in ss. 732.216-732.228, applies, or may apply, unless a written demand is made by a creditor as specified under s. 732.2211, Florida Statutes. The written demand must be filed with the clerk.

ALL CLAIMS NOT FILED WITHIN THE TIME PERIODS SET FORTH IN FLORIDA STATUTES SECTION 733.702 WILL BE FOREVER BARRED.

NOTWITHSTANDING THE TIME PERIODS SET FORTH ABOVE, ANY CLAIM FILED TWO (2) YEARS OR MORE AFTER THE DECEDENT'S DATE OF DEATH IS BARRED.

The date of first publication of this notice is June 26, 2026.

**Jennifer Elizabeth Mannina**  
 Personal Representative  
 6035 Sea Ranch Drive, Unit 412  
 Hudson, FL 34667  
 (address)  
 Wayne R. Coulter  
 Attorney for Personal Representative  
 Email Addresses:  
 info@delzercoulter.com  
 karen@delzercoulter.com  
 Florida Bar No. 114585  
 7920 U.S. Highway 19  
 Port Richey, FL 34668  
 (address)  
 Telephone: (727) 848-3404  
 June 26; July 3, 2026 26-01486P

FIRST INSERTION

**NOTICE TO CREDITORS IN THE CIRCUIT COURT FOR PASCO COUNTY, FLORIDA PROBATE DIVISION File No. 26-CP-23 Division Probate IN RE: ESTATE OF WILLIAM THOMAS SPEIGHT Deceased.**

The administration of the estate of WILLIAM THOMAS SPEIGHT, deceased, whose date of death was November 21, 2025, is pending in the Circuit Court for Pasco County, Florida, Probate Division, the address of which is 38053 Live Oak Avenue, Dade City, Florida 33523. The names and addresses of the personal representative and the personal representative's attorney are set forth below.

All creditors of the decedent and other persons having claims or demands against decedent's estate on whom a copy of this notice is required to be served must file their claims with this court ON OR BEFORE THE LATER OF 3 MONTHS AFTER THE TIME OF THE FIRST PUBLICATION OF THIS NOTICE OR 30 DAYS AFTER THE DATE OF SERVICE OF A COPY OF THIS NOTICE ON THEM.

All other creditors of the decedent and other persons having claims or demands against decedent's estate must file their claims with this court WITHIN 3 MONTHS AFTER THE DATE OF THE FIRST PUBLICATION OF THIS NOTICE.

The personal representative has no

duty to discover whether any property held at the time of the decedent's death by the decedent or the decedent's surviving spouse is property to which the Florida Uniform Disposition of Community Property Rights at Death Act as described in ss. 732.216-732.228, Florida Statutes, applies, or may apply, unless a written demand is made by a creditor as specified under s. 732.2211, Florida Statutes. The written demand must be filed with the clerk.

ALL CLAIMS NOT FILED WITHIN THE TIME PERIODS SET FORTH IN FLORIDA STATUTES SECTION 733.702 WILL BE FOREVER BARRED.

NOTWITHSTANDING THE TIME PERIOD SET FORTH ABOVE, ANY CLAIM FILED TWO (2) YEARS OR MORE AFTER THE DECEDENT'S DATE OF DEATH IS BARRED.

The date of first publication of this notice is June 26, 2026.

**Personal Representative:**  
**STEPHEN EDWARD BECKWITH**  
 330 NE 50th Court  
 Ocala, Florida 34470  
 Attorney for Personal Representative:  
 Kristopher A. Vanderlaan Attorney  
 Florida Bar Number: 0585408  
 VANDERLAAN & VANDERLAAN,  
 P.A.  
 36 SE 15th Terrace  
 Ocala, Florida 34471  
 Telephone: (352) 789-6744  
 Fax: (352) 789-6791  
 E-Mail: pleadings@lawofficeocala.com  
 E-Mail: kris@lawofficeocala.com  
 June 26; July 3, 2026 26-01460P

--- PUBLIC NOTICES / ESTATE ---

FIRST INSERTION

ESTANCIA AT WIREGRASS COMMUNITY DEVELOPMENT DISTRICT

NOTICE OF PUBLIC HEARING TO CONSIDER THE ADOPTION OF THE FY 2027 BUDGET; NOTICE OF PUBLIC HEARING TO CONSIDER THE ADOPTION OF AN AMENDED ASSESSMENT METHODOLOGY FUNDING THE PORTION OF THE OPERATIONS AND MAINTENANCE SPECIAL ASSESSMENT FOR AMENITY CENTER OPERATIONS AND FOR ADOPTION OF AN ASSESSMENT ROLL, AND THE LEVY, COLLECTION, AND ENFORCEMENT OF THE SAME; AND NOTICE OF REGULAR BOARD OF SUPERVISORS' MEETING.

The Board of Supervisors ("Board") for the Estancia at Wiregrass Community Development District ("District") will hold the following public hearings and regular meeting on:

DATE: August 18, 2026
TIME: 6:00 P.M.
LOCATION: Estancia at Wiregrass Clubhouse
4000 Estancia Boulevard
Wesley Chapel, Florida 33543.

The first public hearing is being held pursuant to Chapter 190, Florida Statutes, to receive public comment and objections on the District's proposed budget ("Proposed Budget") for the fiscal year beginning October 1, 2026, and ending September 30, 2027 ("FY 2027").

Description of Assessments

The District imposes O&M Assessments on benefitted property within the District for the purpose of funding the District's general administrative, operations, and maintenance budget.

Table with 6 columns: Land Use, Total Acres, Units / Acres, Existing EAU Factor for all O&M Assessments, Proposed EAU Factor for portion of O&M Assessment for Amenity Center Budget, Proposed Annual O&M Assessment if Methodology Is Not Revised\*, Proposed Total Annual O&M Assessment if Methodology Is Revised\*.

\*includes collection costs and early payment discounts

NOTE: THE DISTRICT RESERVES ALL RIGHTS TO CHANGE THE LAND USES, NUMBER OF UNITS, EAU FACTORS, AND O&M ASSESSMENT AMOUNTS AT THE PUBLIC HEARING, WITHOUT FURTHER NOTICE.

The proposed O&M Assessments as stated include collection costs and/or early payment discounts imposed on assessments collected by the Pasco County ("County") Tax Collect on the tax bill.

For FY 2027, the District intends to have the County Tax Collector collect the O&M Assessments imposed on certain developed property.

Additional Provisions

The public hearing and meeting are open to the public and will be conducted in accordance with the provisions of Florida law.

Any person requiring special accommodations at the public hearings or meeting because of a disability or physical impairment should contact the District Manager's Office at least forty-eight (48) hours prior to the public hearings and meeting.

Please note that all affected property owners have the right to appear at the public hearings and meeting and may also file written objections with the District Manager's Office within twenty days of publication of this notice.

Richard McGrath
District Manager

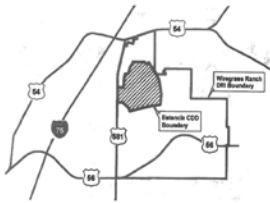

June 26, 2026

26-01454P

FIRST INSERTION

NOTICE OF RULE DEVELOPMENT BY THE VIDA'S WAY COMMUNITY DEVELOPMENT DISTRICT

In accordance with Chapters 120 and 190, Florida Statutes, the Vida's Way Community Development District ("District") hereby gives notice of its intention to develop revised Rules of Procedure to govern the operations of the District.

The proposed Rules of Procedure will address such areas as the Board of Supervisors, officers and voting, district offices, public information and inspection of records, policies, public meetings, hearings and workshops.

The purpose and effect of the revised Rules of Procedure is to provide for efficient and effective District operations and to ensure compliance with recent changes to Florida law.

A copy of the proposed revised Rules of Procedure and the related incorporated documents, if any, may be obtained by contacting the District Manager, c/o Wrathell, Hunt and Associates, LLC, 2300 Glades Road, Suite 410W, Boca Raton, Florida 33431, Phone (561) 571-0010.

Kristen Suit, District Manager
Vida's Way Community Development District
June 26, 2026

26-01475P

FIRST INSERTION

Notice Under Fictitious Name Law Pursuant to Section 865.09, Florida Statutes

NOTICE IS HEREBY GIVEN that the undersigned, desiring to engage in business under the fictitious name of RNJ FOOD AND GROCERIES located at 39010 FL-575 in the City of DADE CITY, Pasco, FL 33523 intends to register the said name with the Division of Corporations of the Department of State, Tallahassee, Florida.

Dated this 23rd day of June, 2026
MD IMRAN HAJAREE
June 26, 2026

26-01481P

FIRST INSERTION

Notice Under Fictitious Name Law Pursuant to Section 865.09, Florida Statutes

NOTICE IS HEREBY GIVEN that the undersigned, desiring to engage in business under the Fictitious Name of CKR Solar & Storage located at 4409 Land O Lakes Blvd in the City of Land O Lakes, Pasco, FL 34639 intends to register the said name with the Division of Corporations of the Department of State, Tallahassee, Florida.

Dated this 19th day of June, 2026
CKR SOLAR, LLC
June 26, 2026

26-01466P

FIRST INSERTION

Notice of Public Hearing and Board of Supervisors Meeting of the Heritage Pines Community Development District

The Board of Supervisors (the "Board") of the Heritage Pines Community Development District (the "District") will hold a public hearing and a meeting Tuesday, July 21, 2026, at 2:00 p.m. at Heritage Pines Country Club Meeting Room located at 11524 Scenic Hills Boulevard, Hudson, Florida 34667.

The purpose of the public hearing is to receive public comments on the proposed adoption of the District's fiscal year 2026-2027 proposed budget and the proposed levy of its annually recurring non-ad valorem special assessments for operation and maintenance to fund the items described in the proposed budget (the "O&M Assessments").

At the conclusion of the public hearing, the Board will, by resolution, adopt a final budget, provide for the levy, collection, and enforcement of the O&M Assessments, and certify an assessment roll. A meeting of the Board will also be held where the Board may consider any other business that may properly come before it.

A copy of the proposed budget, preliminary assessment roll, and the agenda may be viewed on the District's website at https://heritagepinesdcd.net/ at least 2 days before the meeting or may be obtained by contacting the District Manager's office via email at adamsc@whhassociates.com or via phone at (239) 498-9020.

The table below presents the proposed schedule of the O&M Assessments. Amounts are preliminary and subject to change at the meeting and in any future year.

Table with 6 columns: Land Use, Total # of Units / Acres, Equivalent Assessment Unit Factor, Proposed O&M Assessment\* (October 1, 2026 - September 30, 2027), Current O&M Assessment\* (October 1, 2025 - September 30, 2026), Change in Annual Dollar Amount.

\*Annual O&M Assessment includes County collection costs and early payment discounts

The O&M Assessments (in addition to debt assessments, if any) will appear on November 2026 property tax bill. Amount shown includes all applicable collection costs. Property owner is eligible for a discount of up to 4% if paid early.

The County Tax Collector will collect the assessments for all lots and parcels within the District. Alternatively, the District may elect to directly collect its assessments in accordance with Chapter 190, Florida Statutes.

The public hearing and meeting are open to the public and will be conducted in accordance with the provisions of Florida law for community development districts.

In accordance with the provisions of the Americans with Disabilities Act, any person requiring special accommodations because of a disability or physical impairment should contact the District Manager's office at least 2 business days prior to the meeting.

Each person who decides to appeal any decision made by the Board with respect to any matter considered at the public hearing or meeting is advised that person will need a record of proceedings and that accordingly, the person may need to ensure that a verbatim record of the proceedings is made, including the testimony and evidence upon which such appeal is to be based.

Chuck Adams
District Manager



June 26, 2026

26-01487P

FIRST INSERTION

NOTICE TO CREDITORS IN THE CIRCUIT COURT OF THE 6TH JUDICIAL CIRCUIT IN AND FOR PASCO COUNTY, FLORIDA PROBATE DIVISION File No. 2026CP000965CPAXES IN RE: ESTATE OF CHERYL FERGUSON VITALE, Deceased.

The administration of the estate of CHERYL FERGUSON VITALE, Deceased, whose date of death was October 15, 2025, is pending in the Circuit Court for PASCO County, Florida, Probate Division, the address of which is 38053 Live Oak Ave., Dade City, FL 33523.

All creditors of the decedent and other persons having claims or demands against decedent's estate on whom a copy of this notice is required to be served must file their claims with this court WITHIN THE LATER OF 3 MONTHS AFTER THE TIME OF THE FIRST PUBLICATION OF THIS NOTICE OR 30 DAYS AFTER THE DATE OF SERVICE OF A COPY OF THIS NOTICE ON THEM.

All other creditors of the decedent and other people having claims or demands against decedent's estate must file their claims with this court WITHIN 3 MONTHS AFTER THE DATE OF THE FIRST PUBLICATION OF THIS

NOTICE.

ALL CLAIMS NOT FILED WITHIN THE TIME PERIODS SET FORTH IN SECTION 733.702 OF THE FLORIDA PROBATE CODE WILL BE FOREVER BARRED.

NOTWITHSTANDING THE TIME PERIODS SET FORTH ABOVE, ANY CLAIM FILED TWO (2) YEARS OR MORE AFTER THE DECEDENT'S DATE OF DEATH IS BARRED.

A personal representative or curator has no duty to discover whether any property held at the time of the decedent's death by the decedent or the decedent's surviving spouse is property to which the Florida Uniform Disposition of Community Property Rights at Death Act as described in sections 732.216-732.228, applies, or may apply, unless a written demand is made by a creditor as specified under section 732.2211.

The date of first publication of this notice is June 26, 2026.

MEGHAN VITALE, Personal Representative
Attorney for Personal Representative: Scott R. Bugay, Esquire
Florida Bar No. 5207
2501 Hollywood Blvd. Suite 206
Hollywood, Florida 33020
Telephone: (954)767-3399
Fax: (305) 945-2905
Primary Email: Scott@srblawyers.com
Secondary Email: angelica@srblawyers.com
June 26; July 3, 2026 26-01448P

FIRST INSERTION

NOTICE TO CREDITORS IN THE CIRCUIT COURT OF THE 6TH JUDICIAL CIRCUIT IN AND FOR PASCO COUNTY, FLORIDA PROBATE DIVISION File No. 2026CP000784CPAXES IN RE: ESTATE OF PEGGY JEAN RUSS, Deceased.

The administration of the estate of PEGGY JEAN RUSS, Deceased, whose date of death was February 11, 2026, is pending in the Circuit Court for PASCO County, Florida, Probate Division, the address of which is 38053 Live Oak Ave., Dade City, FL 33523.

All creditors of the decedent and other persons having claims or demands against decedent's estate on whom a copy of this notice is required to be served must file their claims with this court WITHIN THE LATER OF 3 MONTHS AFTER THE TIME OF THE FIRST PUBLICATION OF THIS NOTICE OR 30 DAYS AFTER THE DATE OF SERVICE OF A COPY OF THIS NOTICE ON THEM.

All other creditors of the decedent and other people having claims or demands against decedent's estate must file their claims with this court WITHIN 3 MONTHS AFTER THE DATE OF THE FIRST PUBLICATION OF THIS

NOTICE.

ALL CLAIMS NOT FILED WITHIN THE TIME PERIODS SET FORTH IN SECTION 733.702 OF THE FLORIDA PROBATE CODE WILL BE FOREVER BARRED.

NOTWITHSTANDING THE TIME PERIODS SET FORTH ABOVE, ANY CLAIM FILED TWO (2) YEARS OR MORE AFTER THE DECEDENT'S DATE OF DEATH IS BARRED.

A personal representative or curator has no duty to discover whether any property held at the time of the decedent's death by the decedent or the decedent's surviving spouse is property to which the Florida Uniform Disposition of Community Property Rights at Death Act as described in sections 732.216-732.228, applies, or may apply, unless a written demand is made by a creditor as specified under section 732.2211.

The date of first publication of this notice is June 26, 2026.

TWANADA RUSS, Personal Representative
Attorney for Personal Representative: Scott R. Bugay, Esquire
Florida Bar No. 5207
2501 Hollywood Blvd. Suite 206
Hollywood, Florida 33020
Telephone: (954)767-3399
Fax: (305) 945-2905
Primary Email: Scott@srblawyers.com
Secondary Email: genesis@srblawyers.com
June 26; July 3, 2026 26-01443P

FIRST INSERTION

NOTICE TO CREDITORS IN THE CIRCUIT COURT FOR PASCO COUNTY, FLORIDA PROBATE DIVISION File No. 2026CP000752CPAXWS IN RE: ESTATE OF JAMES G. CEGLIO Deceased.

TO ALL PERSONS HAVING CLAIMS OR DEMANDS AGAINST THE ABOVE ESTATE:

You are hereby notified that an Order of Summary Administration will be filed in the estate of James G. Ceglie, deceased, File Number 2026CP-000752CPAXWS, by the Circuit Court for Pasco County, Florida, Probate Division, the address of which is P.O. Box 338 New Port Richey, FL 34656-0338; that the decedent's date of death was November 29, 2025; that the total value of the estate is \$4,600.00 and that the names and addresses of those to whom it will be assigned by such order are:

Name Address
Charles Ceglie
244 Sherborne Dr
Columbus, OH 43219

ALL INTERESTED PERSONS ARE NOTIFIED THAT:

All creditors of the estate of the decedent and persons having claims or demands against the estate of the decedent must file their claims with this court WITHIN THE TIME PERIODS SET FORTH IN SECTION 733.702 OF THE FLORIDA PROBATE CODE.

ALL CLAIMS AND DEMANDS NOT SO FILED WILL BE FOREVER BARRED.

NOTWITHSTANDING ANY OTHER APPLICABLE TIME PERIOD, ANY CLAIM FILED TWO (2) YEARS AFTER THE DECEDENT'S DATE OF DEATH IS BARRED.

The date of first publication of this Notice is June 26, 2026.

Person Giving Notice: Charles Ceglie
244 Sherborne Dr
Columbus, OH 43219
Attorney for Person Giving Notice: Jessa M. Gary
Florida Bar Number: 92351
300 W. Wilson Bridge Road, Suite 170
Worthington, Ohio 43085
Telephone: (614) 221-2121
Email: jgary@isaacwiles.com
June 26; July 3, 2026 26-01444P

FIRST INSERTION

Fictitious Name Notice

Notice is hereby given that Florida Educators Insurance LLC, owner, desiring to engage in business under the fictitious name of FEI & GAC located at 2660 Stonewood Park Loop, Land O Lakes, Florida 33701 intends to register the said name in Pasco county with the Division of Corporations, Florida Department of State, pursuant to section 865.09 of the Florida Statutes.
June 26, 2026 26-01465P

--- PUBLIC NOTICES / ESTATE ---

FIRST INSERTION

**NOTICE UNDER FICTITIOUS NAME LAW PURSUANT TO SECTION 865.09, FLORIDA STATUTES**

NOTICE IS HEREBY GIVEN that Karen Shows will engage in business under the fictitious name SOLSTICE HOME LIGHTING, with a physical address 6617 Tower Drive Hudson, Florida 34667, with a mailing address 6617 Tower Drive Hudson, Florida 34667, and already registered the name mentioned above with the Florida Department of State, Division of Corporations.  
June 26, 2026 26-01451P

FIRST INSERTION

**NOTICE OF PUBLIC SALE**

Notice is hereby given that on 07/10/2026, at 10:30AM, the following property will be sold at public auction pursuant to F.S. 715.109: A 1983 HONE recreational vehicle, vehicle identification number 1H9PH052XD1025515, and all personal items located inside the recreational vehicle. Last Tenant: Laurence Warren Kraig, All Unknown Beneficiaries, Successors, Assigns, and Devisees of Laurence Warren Kraig, Unknown Party or Parties in Possession. Sale to be held at: Rainbow Village of Zephyrhills, 4150 Lane Road, Zephyrhills, Florida 33541, (813) 782-5075.  
June 26; July 3, 2026 26-01491P

FIRST INSERTION

**NOTICE OF PUBLIC SALE**

Notice is hereby given that on 07/10/2026, at 10:30 a.m., the following property will be sold at public auction pursuant to F.S. 715.109: A 1973 HILC mobile home bearing vehicle identification number 02611859G and all personal items located inside the mobile home. Last Tenant: Marilyn Revellese, Frank Revellese, All Unknown Beneficiaries, Heirs, Successors, and Assigns of Marilyn Revellese, All Unknown Beneficiaries, Heirs, Successors, and Assigns of Frank Revellese and Unknown Party or Parties in Possession. Sale to be held at: Bedrock Wood Dale LLC, 37924 Boston Avenue, Zephyrhills, Florida 33542, (813) 782-1615.  
June 26; July 3, 2026 26-01493P

FIRST INSERTION

**NOTICE TO CREDITORS IN THE CIRCUIT COURT FOR PASCO COUNTY, FLORIDA PROBATE DIVISION File No. 26-CP-815 IN RE: ESTATE OF CHARLES ELIAS SIEGER JR., Deceased.**

The administration of the estate of CHARLES ELIAS SIEGER, deceased, whose date of death was April 14, 2026, is pending in the Circuit Court for Pasco County, Florida, Probate Division, the address of which is 38053 Live Oak Ave, Dade City, FL 33523. The names and addresses of the curator and the curator's attorney are set forth below.

All creditors of the decedent and other persons having claims or demands against decedent's estate, on whom a copy of this notice is required to be served, must file their claims with this court ON OR BEFORE THE LATER OF 3 MONTHS AFTER THE TIME OF THE FIRST PUBLICATION OF THIS NOTICE OR 30 DAYS AFTER THE DATE OF SERVICE OF A COPY OF THIS NOTICE ON THEM.

All other creditors of the decedent and other persons having claims or demands against decedent's estate must file their claims with this court WITHIN 3 MONTHS AFTER THE DATE OF THE FIRST PUBLICATION OF THIS NOTICE.

The personal representative has no

duty to discover whether any property held at the time of the decedent's death by the decedent or the decedent's surviving spouse is property to which the Florida Uniform Disposition of Community Property Rights at Death Act as described in ss. 732.216-732.228, applies, or may apply, unless a written demand is made by a creditor as specified under s. 732.2211, Florida Statutes.

ALL CLAIMS NOT FILED WITHIN THE TIME PERIODS SET FORTH IN FLORIDA STATUTES SECTION 733.702 WILL BE FOREVER BARRED.

NOTWITHSTANDING THE TIME PERIOD SET FORTH ABOVE, ANY CLAIM FILED TWO (2) YEARS OR MORE AFTER THE DECEDENT'S DATE OF DEATH IS BARRED.

The date of first publication of this notice is: June 26, 2026.

**Robert D. Hines**  
Curator

1312 W. Fletcher Avenue, Suite B  
Tampa, FL 33612

Robert D. Hines, Esq.  
Attorney for Personal Representative  
Florida Bar No. 0413550  
Hines Norman Hines, P.L.  
1312 W. Fletcher Avenue, Suite B  
Tampa, FL 33612  
Telephone: 813-265-0100  
Email: rhines@hnh-law.com  
Secondary Email:  
jrivera@hnh-law.com  
June 26; July 3, 2026 26-01445P

FIRST INSERTION

**NOTICE OF RECEIPT OF AN APPLICATION THE SOUTHWEST FLORIDA WATER MANAGEMENT DISTRICT**

Notice is hereby given that the Southwest Florida Water Management District has received request to withdraw the permit application number 911773 from Connerton School Development, LLC 6457 Sunset Drive Miami, FL 33143. Application received: 2/14/2025. Proposed activity: residential private school. Project name: Connerton Charter School Access, Drainage & Utilities Phase 2. Project size: 17.30 acres Location: Section(s) 19,30, Township 25 South, Range 19 East, in Pasco County. Outstanding Florida Water: no. Aquatic preserve: no. The withdrawal is effective as of June 23, 2026.

The application is available for public inspection Monday through Friday at 7601 U.S. Highway 301 North, Tampa, Florida 33637 or through the "Application & Permit Search Tools" function on the District's website at www.watermatters.org/permits/. Interested persons may inspect a copy of the application and submit written comments concerning the application. Comments must include the permit application number and be received within 14 days from the date of this notice. If you wish to be notified of intended agency action or an opportunity to request an administrative hearing regarding the application, you must send a written request referencing the permit application number to the Southwest Florida Water Management District, Regulation Bureau, 7601 U.S. Highway 301 North, Tampa, Florida 33637 or submit your request through the District's website at www.watermatters.org. The District does not discriminate based on disability. Anyone requiring accommodation under the ADA should contact the Regulation Bureau at (813)985-7481 or 1(800)836-0797, TDD only 1(800)231-6103.  
June 26, 2026 26-01488P

FIRST INSERTION

**NOTICE OF RULE DEVELOPMENT BY THE DEL WEBB RIVER RESERVE COMMUNITY DEVELOPMENT DISTRICT**

In accordance with Chapters 120 and 190, Florida Statutes, the Del Webb River Reserve Community Development District ("District") hereby gives notice of its intention to develop revised Rules of Procedure to govern the operations of the District. The proposed rule number is ROP-2026-1.

The revised Rules of Procedure will address such areas as the Board of Supervisors, officers and voting, district offices, public information and inspection of records, policies, public meetings, hearings and workshops, rulemaking proceedings, competitive purchase including procedure under the Consultants' Competitive Negotiation Act, procedure regarding auditor selection, purchase of insurance, pre-qualification, construction contracts, goods, supplies and materials, maintenance services, contractual services and protests with respect to proceedings, as well as any other area of the general operation of the District.

The purpose and effect of the revised Rules of Procedure is to provide for efficient and effective District operations and to ensure compliance with recent changes to Florida law. The specific grant of rulemaking authority for the adoption of the proposed revised Rules of Procedure includes Sections 190.011(5), 190.011(15) and 190.035, Florida Statutes. The specific laws implemented in the proposed revised Rules of Procedure include, but are not limited to, Sections 112.08, 112.3143, 112.31446, 112.3145, 119.07, 119.0701, 120.54, 120.542, 120.5435, 120.56, 120.69, 120.81, 189.053, 189.069, 190.006, 190.007, 190.008, 190.011, 190.033, 190.035, 218.33, 218.391, 218.391, 255.05, 255.0518, 255.0525, 255.20, 286.0105, 286.011, 286.012, 286.0113, 286.0114, 287.017, 287.055, and 287.084, Florida Statutes.

A copy of the proposed revised Rules of Procedure and the related incorporated documents, if any, may be obtained by contacting the District Manager, c/o Wrathell, Hunt & Associates, LLC, 2330 Glades Road, Suite 410W, Boca Raton, Florida 33431, Phone (561) 571-0010.

Kristen Suit, District Manager  
Del Webb River Reserve Community Development District  
June 26, 2026 26-01461P



**Email your Legal Notice**

*legal@businessobserverfl.com*

**Deadline Wednesday at noon • Friday Publication**

SARASOTA • MANATEE • HILLSBOROUGH • PASCO  
PINELLAS • POLK • LEE • COLLIER • CHARLOTTE

FLORIDA'S NEWSPAPER FOR THE C-SUITE  
**Business Observer**

--- PUBLIC NOTICES / SALES / ESTATE ---

FIRST INSERTION

**NOTICE OF PUBLIC SALE**

Pursuant to Section 715.109, notice is hereby given that the following property will be offered for public sale and will sell at public outcry to the highest and best bidder for cash:

A 1978 Pontiac Park Model Travel Trailer, ID number 3583518831, title No.: 14991472, 35' Park Model Travel Trailer and the contents therein, if any abandoned by previous owner, Christina Duefield.

On Wednesday, July 9, 2026, at 9:00 a.m. at Sunny Grove MHC, d/b/a Ducky's Day Off Park 34408 State Road

54 West, Lot 170, Wesley Chapel, FL 33543 in Pasco County, Dated: June 24, 2026  
**SHUMAKER, LOOP & KENDRICK, LLP**  
 By: \_\_\_/s/ Anna C Nelson  
 Anna C Nelson, Esq.  
 Florida Bar No. 1059194  
 240 S. Pineapple Ave., Box 49948  
 Sarasota, Florida 34230  
 anelson@shumaker.com  
 aschaffer@humaker.com  
 eholland@shumaker.com  
 Telephone: (941) 366-6660  
 Facsimile: (941) 366-3999  
 Attorneys for Sunny Grove MHC, LLC  
 June 26; July 3, 2026 26-01495P

FIRST INSERTION

**NOTICE TO CREDITORS IN THE CIRCUIT COURT FOR PASCO COUNTY, FLORIDA PROBATE DIVISION REF: 26-CP000828CPAXES IN RE: ESTATE OF TINA MARIE BAITINGER Deceased.**

The administration of the estate of TINA MARIE BAITINGER, deceased, whose date of death was July 5, 2025, is pending in the Circuit Court for Pasco County, Florida, Probate Division; File No. 26-CP000828CPAXES, the address of which is 7530 Little Road, New Port Richey, FL 34654. The names and addresses of the Personal Representative and the Personal Representative's attorney are set forth below.

All creditors of the decedent and other persons having claims or demands against decedent's estate on whom a copy of this notice is required to be served must file their claims with this court WITHIN THE LATER OF 3 MONTHS AFTER THE TIME OF THIS NOTICE OR 30 DAYS AFTER THE DATE OF SERVICE OF A COPY OF THIS NOTICE ON THEM.  
 All other creditors of the decedent and other persons having claims or demands against decedent's estate must file their claims with this court WITHIN 3 MONTHS AFTER THE DATE OF THE FIRST PUBLICATION OF THIS NOTICE.

The Personal Representative or Curator has no duty to discover whether any property held at the time of decedent's death by the decedent or the decedent's surviving spouse is property to which the Florida Uniform Disposition of Community Property Rights at Death Act, as described in section 732.216-732.228, applies, or may apply, unless a written demand is made by a creditor as specified under section 732.2211.

ALL CLAIMS NOT FILED WITHIN THE TIME PERIODS SET FORTH IN SECTION 733.702 OF THE FLORIDA PROBATE CODE WILL BE FOREVER BARRED.

NOTWITHSTANDING THE TIME PERIODS SET FORTH ABOVE, ANY CLAIM FILED TWO (2) YEARS OR MORE AFTER THE DECEDENT'S DATE OF DEATH IS BARRED.

The date of first publication of this notice is June 26, 2026.

**Personal Representative:**  
**MICHAEL ANTHONY BAITINGER**  
 c/o Strohauser Mannion Son  
 Cleveland Street, Suite 300  
 Clearwater, FL 33755  
 Attorney for Personal Representative:  
 Stacy Strohauser Son, Esquire  
**STROHAUSER MANNION SON**  
 1150 Cleveland Street, Suite 300  
 Clearwater, FL 33755  
 stacy@smslaw.net  
 Tel: 727-461-6100  
 Fax: 727-447-6899  
 FBN: 640891  
 June 26; July 3, 2026 26-01494P

FIRST INSERTION

**NOTICE OF SALE**

IN THE CIRCUIT COURT FOR THE SIXTH JUDICIAL CIRCUIT IN AND FOR PASCO COUNTY, FLORIDA  
**CASE NO: 2016-CA-009237-O BAY AREA HOMES, LLC, A FLORIDA LIMITED LIABILITY COMPANY Plaintiff(s), REF #:2024-CA-003132**

**v. JIMMY SMITH Defendant(s),**  
 NOTICE IS HEREBY GIVEN pursuant to a Final Judgment dated March 5, 2026 entered in Civil Case No.: 2024-CA-003132, of the Circuit Court of the Sixth Judicial Circuit in and for PASCO COUNTY, Florida, wherein BAY AREA HOMES, LLC A FLORIDA LIMITED LIABILITY COMPANY, is Plaintiff, and JIMMY SMITH, is Defendant.

NIKKI ALVAREZ- SOWLES, ESQ., Clerk of the Court, will sell the highest bidder for cash at 11:00 a.m. online at www.pasco.realforeclose.com on the 21st day of July, 2026 the following described real property as set forth in said Final Judgment, to wit:

THE PRESERVE AT FAIRWAY OAKS UNIT THREE PB 35 PGS 27-30 LOT 395  
 If you are a person claiming a right to

funds remaining after the sale, you must file a claim with the clerk no later than 60 days after the sale. If you fail to file a claim you will not be entitled to any remaining funds. After 60 days, only the owner of record as of the date of the lis pendens may claim the surplus.

If you are a person with a disability who needs an accommodation in order to participate in this proceeding, you are entitled, at no cost to you, to the provision of certain assistance. Please contact: Public Information Dept., Pasco County Government Center, 7530 Little Rd., New Port Richey, FL 34654. Phone: 727.847.8110 (voice) in New Port Richey 352.521.4274, ext 8110 (voice) in Dade City or 711 for the hearing impaired. Contact should be initiated at least seven days before the scheduled court appearance, or immediately upon receiving this notification if the time before the scheduled appearance is less than seven days

Dated this 17th day of June, 2026  
 /s/ Julius Adams, Esq.  
 Bar Number 104866

Atoms Law, PLLC  
 P.O. Box 8504  
 Tampa, FL 33674  
 727-506-2308  
 julius.adams.esq@gmail.com  
 June 26; July 3, 2026 26-01442W

FIRST INSERTION

**NOTICE TO CREDITORS IN THE CIRCUIT COURT FOR PASCO COUNTY, FLORIDA PROBATE DIVISION File No. 2026CP000883ES IN RE: ESTATE OF Thelma T. Allen a/k/a Thelma Thomas Allen a/k/a Thelma Eunice Allen a/k/a Thelma E. Thomas Deceased.**

The administration of the estate of Thelma T. Allen a/k/a Thelma Thomas Allen a/k/a Thelma Eunice Allen a/k/a Thelma E. Thomas, deceased, whose date of death was January 4, 2026, is pending in the Circuit Court for Pasco County, Florida, Probate Division, the address of which is 38053 Live Oak Avenue, Dade City, Florida 33523. The names and addresses of the personal representative and the personal representative's attorney are set forth below.

All creditors of the decedent and other persons having claims or demands against decedent's estate on whom a copy of this notice is required to be served must file their claims with this court ON OR BEFORE THE LATER OF 3 MONTHS AFTER THE TIME OF THE FIRST PUBLICATION OF THIS NOTICE OR 30 DAYS AFTER THE DATE OF SERVICE OF A COPY OF THIS NOTICE ON THEM. The personal representative has no duty to discover whether any property held at the time of the decedent's death by the decedent or the decedent's surviving

spouse is property to which the Florida Uniform Disposition of Community Property Rights at Death Act as described in ss. 732.216-732.228, Florida Statutes, applies, or may apply, unless a written demand is made by a creditor as specified under s. 732.2211, Florida Statutes. All other creditors of the decedent and other persons having claims or demands against decedent's estate must file their claims with this court WITHIN 3 MONTHS AFTER THE DATE OF THE FIRST PUBLICATION OF THIS NOTICE. ALL CLAIMS NOT FILED WITHIN THE TIME PERIODS SET FORTH IN FLORIDA STATUTES SECTION 733.702 WILL BE FOREVER BARRED. NOTWITHSTANDING THE TIME PERIODS SET FORTH ABOVE, ANY CLAIM FILED TWO (2) YEARS OR MORE AFTER THE DECEDENT'S DATE OF DEATH IS BARRED.

The date of first publication of this notice is June 26, 2026.

**Personal Representative:**  
**Cheryl Haynes**  
 990 Tangelo Circle  
 Bartow, Florida 33830  
 Attorney for Personal Representative:  
 Nancy McClain Alfonso, Esquire  
 Florida Bar Number: 845892  
**ALFONSO HERSCH**  
 Post Office Box 4  
 Dade City, Florida 33526-0004  
 Telephone: (352) 567-5636  
 E-Mail: eserve@alfonsohersch.com  
 Secondary: jerrrod@alfonsohersch.com  
 June 26; July 3, 2026 26-01490P

FIRST INSERTION

**NOTICE TO CREDITORS IN THE CIRCUIT COURT FOR PASCO COUNTY, FLORIDA PROBATE DIVISION File No. 2026-CP-000704-CPAXWS IN RE: ESTATE OF GEORGE SAVVAS Deceased.**

The administration of the estate of George Savvas, deceased, whose date of death was December 8, 2025, is pending in the Circuit Court for Pasco County, Florida, Probate Division, the address of which is 7530 Little Rd., New Port Richey, FL 34654. The names and addresses of the personal representative and the personal representative's attorney are set forth below.

All creditors of the decedent and other persons having claims or demands against decedent's estate on whom a copy of this notice is required to be served must file their claims with this court ON OR BEFORE THE LATER OF 3 MONTHS AFTER THE TIME OF THE FIRST PUBLICATION OF THIS NOTICE OR 30 DAYS AFTER THE DATE OF SERVICE OF A COPY OF THIS NOTICE ON THEM.

All other creditors of the decedent and other persons having claims or demands against decedent's estate must file their claims with this court WITHIN 3 MONTHS AFTER THE DATE OF THE FIRST PUBLICATION OF THIS NOTICE.

The personal representative has no

duty to discover whether any property held at the time of the decedent's death by the decedent or the decedent's surviving spouse is property to which the Florida Uniform Disposition of Community Property Rights at Death Act as described in ss. 732.216-732.228, Florida Statutes, applies, or may apply, unless a written demand is made by a creditor as specified under s. 732.2211, Florida Statutes. The written demand must be filed with the clerk.

ALL CLAIMS NOT FILED WITHIN THE TIME PERIODS SET FORTH IN FLORIDA STATUTES SECTION 733.702 WILL BE FOREVER BARRED.

NOTWITHSTANDING THE TIME PERIODS SET FORTH ABOVE, ANY CLAIM FILED TWO (2) YEARS OR MORE AFTER THE DECEDENT'S DATE OF DEATH IS BARRED.

The date of first publication of this notice is June 26, 2026.

**Personal Representative:**  
**Mark Baertschi**  
 3173 Living Coral Dr.  
 Odessa, Florida 33556  
 Attorney for Personal Representative:  
 Eugene L. Beil, Esq., Attorney  
 Florida Bar Number: 343633  
**BEIL & HAY PA; 12300 US Hwy 19**  
 Hudson, FL 34667  
 phone:(727) 868-2306;  
 Fax: (727) 863-1287  
 E-Mail: elbeil@beilandhay.com  
 Second-E-Mail:  
 webmaster@beilandhay.com  
 June 26; July 3, 2026 26-01469P

FIRST INSERTION

**NOTICE TO CREDITORS (Formal Administration) IN THE CIRCUIT COURT FOR PASCO COUNTY, FLORIDA PROBATE DIVISION CASE NO.: 2025-CP-001736 IN RE: ESTATE OF JOE D. HARVEL, Deceased.**

TO ALL PERSONS HAVING CLAIMS OR DEMANDS AGAINST THE ABOVE ESTATE:

The administration of the estate of JOE D. HARVEL, deceased, whose date of death was April 22, 2025, and whose social security number is XXX-XX-0736, is pending in the Circuit Court for Pasco County, Florida, Probate Division, the address of which is 7530 Little Road, New Port Richey, Florida, 34654. The names and addresses of the Personal Representative and the Personal Representative's attorney are set forth below.

The Personal Representative has no duty to discover whether any property held at the time of the decedent's death by the decedent or the decedent's surviving spouse is property to which the Florida Uniform Disposition of Community Property Rights at Death Act as described in §§ 732.216-228, applies, or may apply, unless a written demand is made by a creditor as specified under § 732.2211.

All creditors of the decedent and other persons having claims or demands against decedent's estate on whom a copy of this notice is required to be served must file their claims with

this court WITHIN THE LATER OF THREE (3) MONTHS AFTER THE TIME OF THE FIRST PUBLICATION OF THIS NOTICE OR THIRTY (30) DAYS AFTER THE DATE OF SERVICE OF A COPY OF THIS NOTICE ON THEM.

All other creditors of the decedent and other persons having claims or demands against decedent's estate must file their claims with this court WITHIN THREE (3) MONTHS AFTER THE DATE OF THE FIRST PUBLICATION OF THIS NOTICE.

ALL CLAIMS NOT FILED WITHIN THE TIME PERIODS SET FORTH IN SECTION 733.702 OF THE FLORIDA PROBATE CODE WILL BE FOREVER BARRED.

NOTWITHSTANDING THE TIME PERIODS SET FORTH ABOVE, ANY CLAIM FILED TWO (2) YEARS OR MORE AFTER THE DECEDENT'S DATE OF DEATH IS BARRED.

The date of first publication of this Notice is June 26, 2026.

/s/ **Amber B. Steadham**  
**AMBER B. STEADHAM,**  
**As Personal Representative**  
 /s/ Steven E. Gurian  
**STEVEN E. GURIAN, ESQ.,**  
 Attorney for  
 Personal Representative  
**EASY ESTATE PROBATE, PLLC**  
 901 Ponce De Leon Boulevard, 6th Floor  
 Coral Gables, Florida 33134  
 Tel: 1-833-973-3279  
 Fax: 1-833-927-3279  
 E-mail: SG@EasyEstateProbate.com  
 Florida Bar No. 101511  
 June 26; July 3, 2026 26-01492P

FIRST INSERTION

**NOTICE OF FORECLOSURE SALE IN THE CIRCUIT COURT OF THE 6TH JUDICIAL CIRCUIT, IN AND FOR PASCO COUNTY, FLORIDA CIVIL DIVISION:**

**CASE NO.: 51-2025-CA-001694-CAAX-WS LAKEVIEW LOAN SERVICING, LLC, Plaintiff, vs. DANIEL RODRIGUEZ; BEACON WOODS EAST HOMEOWNERS' ASSN., INC.; BEACON WOODS EAST MASTER ASSOCIATION, INC.; THE ESTATES AND RESERVE OF BEACON WOODS PROPERTY OWNERS ASSOCIATION, INC.; ANGELICA RODRIGUEZ; UNKNOWN TENANT Defendants.**

NOTICE IS HEREBY GIVEN pursuant to an Order or Final Judgment entered in the above styled cause now pending in said court and as required by Florida Statute 45.031(2), NIKKI ALVAREZ-SOWLES, ESQ. as the Clerk of the Circuit Court for PASCO County shall sell to the highest and best bidder for cash electronically at www.pasco.realforeclose.com at, 11:00 AM on the 27 day of July, 2026, the following described property as set forth in said Final Judgment, to wit:

LOT 79, THE ESTATES OF BEACON WOODS GOLF AND COUNTRY CLUB PHASE 5, ACCORDING TO THE MAP OR PLAT THEREOF, AS RECORDED IN PLAT BOOK 30, PAGE 104, OF THE PUBLIC RECORDS OF PASCO COUNTY, FLORIDA. PROPERTY ADDRESS: 8539 CORAL CREEK LOOP, HUDSON, FL 34667

IF YOU ARE A PERSON CLAIMING A RIGHT TO FUNDS REMAINING AFTER THE SALE, YOU MUST FILE A CLAIM WITH THE CLERK NO LATER THAN THE DATE THAT

THE CLERK REPORTS THE FUNDS AS UNCLAIMED. IF YOU FAIL TO FILE A CLAIM, YOU WILL NOT BE ENTITLED TO ANY REMAINING FUNDS. AFTER THE FUNDS ARE REPORTED AS UNCLAIMED, ONLY THE OWNER OF RECORD AS OF THE DATE OF THE LIS PENDENS MAY CLAIM THE SURPLUS.

If you are a person with a disability who needs an accommodation in order to participate in this proceeding, you are entitled, at no cost to you, to the provision of certain assistance. Please contact: Public Information Dept., Pasco County Government Center, 7530 Little Rd., New Port Richey, FL 34654; Phone: 727.847.8110 (voice) in New Port Richey, 352.521.4274, ext 8110 (voice) in Dade City, Or 711 for the hearing impaired. Contact should be initiated at least seven days before the scheduled court appearance, or immediately upon receiving this notification if the time before the scheduled appearance is less than seven days. The court does not provide transportation and cannot accommodate such requests. Persons with disabilities needing transportation to court should contact their local public transportation providers for information regarding transportation services.

Dated this 23 day of June 2026.

By: /s/ Lindsay Maisonet  
 Lindsay Maisonet, Esq.  
 Bar Number: 93156  
 Submitted by:  
 De Cubas & Lewis, P.A.  
 PO Box 5026  
 Fort Lauderdale, FL 33310  
 Telephone: (954) 453-0365  
 Facsimile: (954) 771-6052  
 Toll Free: 1-800-441-2438  
 DESIGNATED PRIMARY E-MAIL  
 FOR SERVICE PURSUANT TO FLA. R. JUD. ADMIN 2.516  
 eservice@decubaslewis.com  
 25-00738  
 June 26; July 3, 2026 26-01489P

FIRST INSERTION

**NOTICE TO CREDITORS IN THE CIRCUIT COURT FOR PASCO COUNTY, FLORIDA PROBATE DIVISION File No. 2026-CP-000351 IN RE: ESTATE OF FRED E. MARQUIS, Deceased.**

TO ALL PERSONS HAVING CLAIMS OR DEMANDS AGAINST THE ABOVE ESTATE:

You are hereby notified that an Order of Summary Administration has been entered in the estate of FRED E. MARQUIS, deceased, File Number 2026-CP-000351; by the Circuit Court for Pasco County, Florida, Probate Division, the address of which is 7530 Little Road, Suite 105, New Port Richey, FL 34654; that the Decedent's date of death was January 3, 2026; that the total value of the estate is \$39,638.25, and that the names and addresses of those to whom it has been assigned by such Order are:

Beneficiaries: Address  
 ELENA S. MARQUIS  
 1300 Trimiran Place  
 Trinity, FL 34655  
 ALL INTERESTED PERSONS ARE NOTIFIED THAT:

All creditors of the estate of the Decedent and persons having claims or demands against the estate of the Decedent other than those for whom provision for full payment was made in the Order of Summary Administration must file their claims with this court

WITHIN THE TIME PERIODS SET FORTH IN FLORIDA STATUTES SECTION 733.702. ALL CLAIMS AND DEMANDS NOT SO FILED WILL BE FOREVER BARRED. NOTWITHSTANDING ANY OTHER APPLICABLE TIME PERIOD, ANY CLAIM FILED TWO (2) YEARS OR MORE AFTER THE DECEDENT'S DATE OF DEATH IS BARRED.

The Personal Representative has no duty to discover whether any property held at the time of the Decedent's death by the Decedent or the Decedent's surviving spouse is property to which the Florida Uniform Disposition of Community Property Rights at Death Act as described in ss. 732.216-732.228, applies, or may apply, unless a written demand is made by a creditor as specified under s. 732.2211, Florida Statutes.

The date of first publication of this Notice is June 26, 2026.

**Personal Giving Notice:**  
**ELENA S. MARQUIS**  
 1300 Trimiran Place  
 Trinity, FL 34655  
 Attorney for Person Giving Notice:  
 Christopher H. Norman, Esq.  
 Attorney for Petitioners  
 Email: cnorman@hnh-law.com  
 Secondary Email:  
 jnapoli@hnh-law.com  
 Florida Bar No. 821462  
 Hines Norman Hines, P.L.L.C.  
 315 S. Hyde Park Avenue  
 Tampa, FL 33606  
 Telephone: 813-251-8659  
 June 26; July 3, 2026 26-01446P

FIRST INSERTION

**NOTICE OF SALE IN THE COUNTY COURT IN AND FOR PASCO COUNTY, FLORIDA CIVIL ACTION**

CASE NO.: 2026CC000478CCAXWS  
**SAND PEBBLE POINTE III CONDOMINIUM ASSOCIATION, INC. Plaintiff vs. JASSAL BROTHERZ LLC, et al. Defendant(s)**

Notice is hereby given that, pursuant to a Final Judgment of Foreclosure or Order dated 06/23/2026, entered in Civil Case No. 2026CC000478CCAXWS, in the COUNTY COURT in and for PASCO County, Florida, wherein SAND PEBBLE POINTE III CONDOMINIUM ASSOCIATION, INC. is the Plaintiff, and JASSAL BROTHERZ LLC, et al., are the Defendants, Nikki Alvarez-Sowles, Esq., PASCO County Clerk of the Court, will sell the property situated in PASCO County, Florida, described as:

Condominium Unit 1141, SAND PEBBLE POINTE III, together with an undivided interest in the common elements, according to the Declaration of Condominium thereof recorded in Official Records Book 1409, Page 207-249, as amended from time to time, of the Public Records of Pasco County, Florida.  
 Parcel ID#  
 30-25-16-003B-01101-1410  
 at public sale, to the highest and best bidder, for cash, at www.pasco.

June 26; July 3, 2026 26-01478P

FIRST INSERTION

**NOTICE OF FORECLOSURE SALE IN THE CIRCUIT COURT OF THE SIXTH JUDICIAL CIRCUIT IN AND FOR PASCO COUNTY, FLORIDA GENERAL JURISDICTION DIVISION**

**CASE NO. 2025CA002788CAAXES TOWD POINT MORTGAGE TRUST 2021-SJ1, U.S. BANK NATIONAL ASSOCIATION, AS INDENTURE TRUSTEE, Plaintiff, vs. THE UNKNOWN HEIRS, BENEFICIARIES, DEVISEES, GRANTEES, ASSIGNEES, LIENORS, CREDITORS, TRUSTEES AND ALL OTHERS WHO MAY CLAIM AN INTEREST IN THE ESTATE OF BARBARA NIEDOSIK A/K/A BARBARA A. NIEDOSIK, DECEASED, et al. Defendant(s).**

NOTICE IS HEREBY GIVEN pursuant to a Final Judgment of Foreclosure dated March 17, 2026, and entered in 2025CA002788CAAXES of the Circuit Court of the SIXTH Judicial Circuit in and for Pasco County, Florida, wherein TOWD POINT MORTGAGE TRUST 2021-SJ1, U.S. BANK NATIONAL ASSOCIATION, AS INDENTURE TRUSTEE is the Plaintiff and THE UNKNOWN HEIRS, BENEFICIARIES, DEVISEES, GRANTEES, ASSIGNEES, LIENORS, CREDITORS, TRUSTEES AND ALL OTHERS WHO MAY CLAIM AN INTEREST IN THE ESTATE OF BARBARA NIEDOSIK A/K/A BARBARA A. NIEDOSIK, DECEASED; ANN MARIE HOROVITZ; MARY-JO EBERLY; STAGECOACH PROPERTY OWNERS ASSOCIATION, INC. are the Defendant(s). Nikki Alvarez-Sowles, Esq., as the Clerk of the Circuit Court will sell to the highest and best bidder for cash at www.pasco.realforeclose.com, at 11:00 AM, on July 15, 2026, the following described property as set forth in said Final Judgment, to wit:

LOT 31, BLOCK 2, STAGE-COACH VILLAGE - PARCEL 3, ACCORDING TO THE PLAT THEREOF, AS RECORDED IN

PLAT BOOK 34, PAGE 120, OF THE PUBLIC RECORDS OF PASCO COUNTY, FL. Property Address: 25427 SEVEN RIVERS CIR, LAND O LAKES, FL 34639

Any person claiming an interest in the surplus from the sale, if any, other than the property owner as of the date of the lis pendens must file a claim in accordance with Florida Statutes, Section 45.031.

**IMPORTANT AMERICANS WITH DISABILITIES ACT:** If you are a person with a disability who needs an accommodation in order to participate in this proceeding, you are entitled, at no cost to you, to the provision of certain assistance. Please contact: Public Information Dept., Pasco County Government Center, 7530 Little Rd., New Port Richey, FL 34654; Phone: 727.847.2411 (voice) in New Port Richey, 727.847.8028 (voice) in Dade City, Or 711 for the hearing impaired. Contact should be initiated at least seven days before the scheduled court appearance, or immediately upon receiving this notification if the time before the scheduled appearance is less than seven days. The court does not provide transportation and cannot accommodate such requests. Persons with disabilities needing transportation to court should contact their local public transportation providers for information regarding transportation services.

Dated this 23 day of June, 2026.

By: /s/Danielle Salem  
 Danielle Salem, Esquire  
 Florida Bar No. 0058248  
 Communication Email:  
 dsalem@raslg.com  
 ROBERTSON, ANSCHUTZ, SCHNEID, CRANE & PARTNERS, PLLC  
 Attorney for Plaintiff  
 6409 Congress Ave., Suite 100  
 Boca Raton, FL 33487  
 Telephone: 561-241-6901  
 Facsimile: 561-997-6909  
 Service Email: fmail@raslg.com  
 25-311876 - NaP  
 June 26; July 3, 2026 26-01485P

--- ACTIONS / SALES ---

FIRST INSERTION

NOTICE OF FORECLOSURE SALE IN THE CIRCUIT COURT OF THE SIXTH JUDICIAL CIRCUIT, IN AND FOR PASCO COUNTY, FLORIDA

Case No. 2024CA001079CAAXWS Everet Financial, Inc. dba Supreme Lending, Plaintiff, vs. Traci McGuire, et al., Defendants.

and Traci McGuire; United States of America on behalf of the Secretary of Housing and Urban Development are the Defendants, that Nikki Alvarez-Sowles, Pasco County Clerk of Court will sell to the highest and best bidder for cash at, www.pasco.realforeclose.com, beginning at 11:00 AM on the 10th day of August, 2026, the following described property as set forth in said Final Judgment, to wit:

LOT 1489, BEACON SQUARE UNIT 13-A, ACCORDING TO THE PLAT THEREOF, AS RECORDED IN PLAT BOOK 9, PAGE 103, OF THE PUBLIC RECORDS OF PASCO COUNTY, FLORIDA.

TAX ID: 24-26-15-0820-00001-4890 Any person claiming an interest in the

surplus from the sale, if any, other than the property owner as of the date of the lis pendens must file a claim before the clerk reports the surplus as unclaimed.

If you are a person with a disability who needs an accommodation in order to participate in this proceeding, you are entitled, at no cost to you, to the provision of certain assistance. Please contact: Public Information Dept., Pasco County Government Center, 7530 Little Rd., New Port Richey, FL 34654; Phone: 727.847.8110 (voice) in New Port Richey, 352.521.4274, ext 8110 (voice) in Dade City, Or 711 for the hearing impaired. Contact should be initiated at least seven days before the scheduled court appearance, or immediately upon receiving this notification if the time before the scheduled appearance is less than

seven days. The court does not provide transportation and cannot accommodate such requests. Persons with disabilities needing transportation to court should contact their local public transportation providers for information regarding transportation services.

Dated this 22nd day of June, 2026. BROCK & SCOTT, PLLC Attorney for Plaintiff 4919 Memorial Hwy, Suite 135 Tampa, FL 33634 Phone: (954) 618-6955 Fax: (954) 618-6954 FLCourtDocs@brockandscott.com By /s/Justin J. Kelley Justin J. Kelley, Esq. Florida Bar No. 321106 File # 23-F01352 June 26; July 3, 2026 26-01473P

FIRST INSERTION

NOTICE OF ACTION IN THE COUNTY COURT OF THE SIXTH JUDICIAL CIRCUIT IN AND FOR PASCO COUNTY, FLORIDA

CASE NO.: 2026CC003456CCAXWS MHC HACIENDA VILLAGE L.L.C., Plaintiff, vs. HAROLD J. DUFFUS, and STANLEY E. JOUBERT, Defendant(s). TO: Harold J. Duffus 6125 Balboa Avenue Lot No. 156 New Port Richey, Florida 34653 Stanley E. Joubert 5 Foothills Way Tilton, NH 03276-5615 YOU ARE NOTIFIED that an action for money damages, subordination of a first lien and imposition and foreclosure of a statutory landlord's lien upon a mobile home described as that certain 1978 HOMI mobile home in Hacienda Village mobile home park located at 6125 Balboa Avenue, Lot No. 156, New Port Richey, Florida 34653, and bearing Vehicle Identification Numbers T2473644A and

T2473644B, has been filed against you, and you are required to serve a copy of your written defenses, if any, to it on Stanley L. Martin, Plaintiff's attorney, whose address is 4300 W. Cypress Street, Suite 400, Tampa, Florida 33607, within 30 days of the first publication, and file the original with the Clerk of this Court either before service on Plaintiff's attorney or immediately thereafter; otherwise a default will be entered against you for the relief demanded in the complaint or petition. DUE ON OR BEFORE JULY 27TH, 2026

WITNESS, Nichole "Nikki" Alvarez-Sowles, as Clerk of the County Court, and the seal of said Court, at the Court-house at Pasco County, Florida. Dated: June 23, 2026 Nichole "Nikki" Alvarez-Sowles Pasco County Clerk of the Circuit and County Court Haley Joyner Deputy Clerk Publish in the Business Observer Prepared by: Stanley L. Martin (813) 282-5925 June 26; July 3, 2026 26-01479P

FIRST INSERTION

NOTICE OF ACTION IN THE CIRCUIT COURT FOR THE SIXTH JUDICIAL CIRCUIT IN AND FOR PASCO COUNTY, FLORIDA CIRCUIT CIVIL DIVISION

CASE NO.: 2025CA004135CAAXWS FIGURE LENDING LLC Plaintiff(s), vs. JESSICA BISHOP; O'SHAUGHNAHILL SURETY & INSURANCE, INC.; THE UNKNOWN SPOUSE OF JESSICA BISHOP; THE UNKNOWN TENANT IN POSSESSION,, Defendant(s).

TO: THE UNKNOWN SPOUSE OF JESSICA BISHOP LAST KNOWN ADDRESS: 5326 VAN DOREN AVENUE, NEW PORT RICHEY, FL 34652 CURRENT ADDRESS: 5326 VAN DOREN AVENUE, NEW PORT RICHEY, FL 34652 TO: THE UNKNOWN TENANT IN POSSESSION LAST KNOWN ADDRESS: 5326 VAN DOREN AVENUE, NEW PORT RICHEY, FL 34652 CURRENT ADDRESS: 5326 VAN DOREN AVENUE, NEW PORT RICHEY, FL 34652

YOU ARE HEREBY NOTIFIED that a civil action has been filed against you in the Circuit Court of Pasco County, Florida, to foreclose certain real property described as follows:

LOT 66, TOWN AND COUNTRY VILLAS SOUTH ADDITION, ACCORDING TO THE PLAT THEREOF, RECORDED IN PLAT BOOK 6, PAGE(S) 119, OF THE PUBLIC RECORDS OF PASCO COUNTY, FLORIDA. Property address: 5326 Van Doren Avenue, New Port Richey, FL 34652

You are required to file a written response with the Court and serve a copy of your written defenses, if any, to it on Padgett Law Group, whose address is 6267 Old Water Oak Road, Suite 203, Tallahassee, FL 32312, at least thirty (30) days from the date of first publication, and file the original with the clerk of this court either before service on Plaintiff's attorney or immediately thereafter; otherwise, a default will be entered against you for the relief demanded in the complaint. Due on or before 7/27/26

If you are a person with a disability who needs an accommodation in order to participate in this proceeding, you are entitled, at no cost to you, to the provision of certain assistance. Please contact the Public Information Dept., Pasco County Government Center, 7530 Little Rd., New Port Richey, FL 34654; (727) 847-8110 (V) in New Port Richey; (352) 521-4274, ext 8110 (V) in Dade City, at least 7 days before your scheduled court appearance, or immediately upon receiving this notification if the time before the scheduled appearance is less than 7 days; if you are hearing impaired call 711. The court does not provide transportation and cannot accommodate for this service. Persons with disabilities needing transportation to court should contact their local public transportation providers for information regarding transportation services.

DATED this 17th day of June, 2026 CLERK OF THE CIRCUIT COURT As Clerk of the Court (SEAL) BY: Haley Joyner Deputy Clerk Plaintiff Atty: Padgett Law Group 6267 Old Water Oak Road, Suite 203 Tallahassee, FL 32312 attorney@padgettlawgroup.com TDP File No. 25-017078-1 June 26; July 3, 2026 26-01441P

FIRST INSERTION

NOTICE OF FORECLOSURE SALE IN THE CIRCUIT COURT OF THE SIXTH JUDICIAL CIRCUIT IN AND FOR PASCO COUNTY, FLORIDA

CASE NO.: 2026-CA-000061 LAKEVIEW LOAN SERVICING, LLC, Plaintiff, v. MELVIN EDGARDO AYALA FUNEZ, et al., Defendants.

NOTICE is hereby given that Nikki Alvarez-Sowles, Esq., Clerk of the Circuit Court of Pasco County, Florida, will on August 3, 2026, at 11:00 a.m. ET, via the online auction site at www.pasco.realforeclose.com in accordance with Chapter 45, F.S., offer for sale and sell to the highest and best bidder for cash, the following described property situated in Pasco County, Florida, to wit:

TRACT 253 of the unrecorded plat of PARKWOOD ACRES SUBDIVISION UNIT 2, being further described as follows: Commencing at the NE corner of Section 1, Township 25 South, Range 16 East, Pasco County, Florida; go thence N 89 degrees 17' 10" W and along the N line of the aforesaid Section 1 a distance of 25.00 feet; thence S 00 degrees 51' 07" W, a distance of 2025.00 feet to the Point of Beginning; thence continue S 00 degree 51' 07" W, a distance of 100.00 feet; thence N 89 degrees 17' 10" W, a distance of 175.00 feet; thence N 00 degrees 51' 07" E, a distance of 100.00 feet; thence S 89 degrees 17' 10" E a distance of 175.00 feet to the Point of Beginning. Together with a mobile home situated thereon, described as a 2003 Flea, with Vehicle Identification Numbers GAFL335A88134F221 and GAFL335888134F221; Title Numbers 90513334 and 90513297; RP Numbers 12207776 and 12207778, which

is affixed to the afore described real property. Property Address: 12613 Hicks Road, Hudson, FL 34669 pursuant to the Final Judgment of Foreclosure entered in a case pending in said Court, the style and case number of which is set forth above.

Any person claiming an interest in the surplus from the sale, if any, other than the property owner as of the date of the Lis Pendens must file a claim before the clerk reports the surplus as unclaimed.

If the sale is set aside for any reason, the Purchaser at the sale shall be entitled only to a return of the deposit paid. The Purchaser shall have no further recourse against the Mortgagor, the Mortgagee or the Mortgagee's attorney.

If you are a person with a disability who needs an accommodation in order to participate in this proceeding, you are entitled, at no cost to you, to the provision of certain assistance. Please contact either the Pasco County Customer Service Center, 8731 Citizens Drive, New Port Richey, FL 34654, (727) 847-8028 (V) or the Pasco County Risk Management Office, 7536 State Street, New Port Richey, FL 34654, (727) 847-8028 (V) at least 7 days before your scheduled court appearance, or immediately upon receiving this notification if the time before the scheduled appearance is less than 7 days; if you are hearing or voice impaired, call 711.

SUBMITTED on this 23rd day of June, 2026. TIFFANY & BOSCO, P.A. /s/ Kathryn I. Kasper, Esq. Anthony R. Smith, Esq. FL Bar #157147 Kathryn I. Kasper, Esq. FL Bar #621188 Attorneys for Plaintiff OF COUNSEL: Tiffany & Bosco, P.A. 1201 S. Orlando Ave, Suite 430 Winter Park, FL 32789 Telephone: (205) 930-5200 Facsimile: (407) 712-9201 June 26; July 3, 2026 26-01484P

FIRST INSERTION

NOTICE OF ACTION IN THE CIRCUIT COURT OF THE SIXTH JUDICIAL CIRCUIT OF FLORIDA IN AND FOR PASCO COUNTY

CASE NO. 2026CA000982CAAXES LAKEVIEW LOAN SERVICING, LLC, Plaintiff, vs. CANDICE SEWARD, et al., Defendant.

TO: ANY AND ALL UNKNOWN PARTIES CLAIMING BY, THROUGH, UNDER, AND AGAINST ESTATE OF GREGORY MICHAEL MARTANIUK, WHETHER SAID UNKNOWN PARTIES MAY CLAIM AN INTEREST AS SPOUSES, HEIRS, DEVISEES, GRANTEES, OR OTHER CLAIMANTS

YOU ARE HEREBY NOTIFIED that an action for Foreclosure of Mortgage on the following described property:

LOT 6, WILLOW BEND TRACT MF-2, ACCORDING TO THE MAP OR PLAT THEREOF, AS RECORDED IN PLAT BOOK 35, PAGE(S) 102 THROUGH 106, INCLUSIVE, OF THE PUBLIC RECORDS OF PASCO COUNTY, FLORIDA.

has been filed against you and you are required to file a copy of your written defenses, if any, to it on McCalla Raymer Leibert Pierce, LLP, Jamie Juster, Attorney for Plaintiff, whose address is 225 East Robinson Street, Suite 155, Orlando, FL 32801 and file the original with the Clerk of the above-styled Court on or before July 6, 2026 or 30 days from the first publication, otherwise a Judgment may be entered against you for the relief demanded in

the Complaint.

If you are a person with a disability who needs an accommodation in order to participate in this proceeding, you are entitled, at no cost to you, to the provision of certain assistance. Please contact the Public Information Dept., Pasco County Government Center, 7530 Little Rd., New Port Richey, FL 34654; (727) 847-8110 (V) in New Port Richey; (352) 521-4274, ext 8110 (V) in Dade City, at least 7 days before your scheduled court appearance, or immediately upon receiving this notification if the time before the scheduled appearance is less than 7 days; if you are hearing impaired call 711. The court does not provide transportation and cannot accommodate for this service. Persons with disabilities needing transportation to court should contact their local public transportation providers for information regarding transportation services.

WITNESS my hand and seal of this Court this 28 day of May, 2026. NIKKI ALVAREZ-SOWLES, ESQ. CLERK OF COURT OF PASCO COUNTY As Clerk of the Court (SEAL) BY: Shakira Ramirez Pagan 2026-CA-982ES Deputy Clerk

MCCALLA RAYMER LEIBERT PIERCE, LLP 225 East Robinson Street, Suite 155, Orlando, FL 32801 Phone: (407) 674-1850 Fax: (321) 248-0420 Email: AccountsPayables@mccalla.com 25-15467FL June 26; July 3, 2026 26-01468P

FIRST INSERTION

NOTICE OF SALE PURSUANT TO CHAPTER 45 IN THE CIRCUIT COURT OF THE SIXTH JUDICIAL CIRCUIT IN AND FOR PASCO COUNTY, FLORIDA. CIVIL DIVISION

CASE NO. 512025CA004147CAAXES

US BANK TRUST NATIONAL ASSOCIATION, NOT IN ITS INDIVIDUAL CAPACITY BUT SOLELY AS OWNER TRUSTEE FOR VRMTG ASSET TRUST, Plaintiff, vs.

SAMEH GALAL HAMZAH A/K/A SAMEH G. HAMZAH A/K/A SAMEH HAMZAH; NOHA MOUSA A/K/A NOHA AHMED MOUSA; A FIRST CHOICE ROOFING; BANK OF AMERICA, N.A.; BRIDGEWATER COMMUNITY ASSOCIATION, INC.; UNKNOWN TENANT NO. 1; UNKNOWN TENANT NO. 2; and ALL UNKNOWN PARTIES CLAIMING INTERESTS BY, THROUGH, UNDER OR AGAINST A NAMED DEFENDANT TO THIS ACTION, OR HAVING OR CLAIMING TO HAVE ANY RIGHT, TITLE OR INTEREST IN THE PROPERTY HEREIN DESCRIBED, Defendant(s).

NOTICE IS HEREBY GIVEN pursuant to a Summary Final Judgment of Foreclosure dated June 10, 2026, and entered in Case No. 512025CA004147CAAXES of the Circuit Court in and for Pasco County, Florida, wherein US BANK TRUST NATIONAL ASSOCIATION, NOT IN ITS INDIVIDUAL CAPACITY BUT SOLELY AS OWNER TRUSTEE FOR VRMTG ASSET TRUST is Plaintiff and SAMEH GALAL HAMZAH A/K/A SAMEH G. HAMZAH A/K/A SAMEH HAMZAH; NOHA MOUSA A/K/A NOHA AHMED MOUSA; A FIRST CHOICE ROOFING; BANK OF AMERICA, N.A.; BRIDGEWATER COMMUNITY ASSOCIATION, INC.; UNKNOWN TENANT NO. 1; UNKNOWN TENANT NO. 2; and ALL UNKNOWN PARTIES CLAIMING INTERESTS BY, THROUGH, UNDER OR AGAINST A NAMED DEFENDANT TO THIS ACTION, OR HAVING OR CLAIMING TO HAVE ANY RIGHT, TITLE OR INTEREST IN THE PROPERTY HEREIN DESCRIBED, are Defendants, NIKKI

ALVAREZ-SOWLES, ESQ., the Clerk of the Circuit Court, will sell to the highest and best bidder for cash online at www.pasco.realforeclose.com, at 11:00 a.m., on August 10, 2026, the following described property as set forth in said Order or Final Judgment, to-wit:

LOT 26, BLOCK 2, BRIDGEWATER PHASE 1 AND 2, ACCORDING TO THE MAP OR PLAT THEREOF, AS RECORDED IN PLAT BOOK 48, PAGE(S) 110 THROUGH 126, INCLUSIVE, OF THE PUBLIC RECORDS OF PASCO COUNTY, FLORIDA..

ANY PERSON CLAIMING AN INTEREST IN THE SURPLUS FROM THE SALE, IF ANY, OTHER THAN THE PROPERTY OWNER AS OF THE DATE OF THE LIS PENDENS MUST FILE A CLAIM BEFORE THE CLERK REPORTS THE SURPLUS AS UNCLAIMED. THE COURT, IN ITS DISCRETION, MAY ENLARGE THE TIME OF THE SALE. NOTICE OF THE CHANGED TIME OF SALE SHALL BE PUBLISHED AS PROVIDED HEREIN.

Pursuant to Florida Statute 45.031(2), this notice shall be published twice, once a week for two consecutive weeks, with the last publication being at least 5 days prior to the sale.

In accordance with the Americans with Disabilities Act of 1990, persons needing special accommodation to participate in this proceeding should contact the Clerk of the Court not later than five business days prior to the proceeding at the Pasco County Court-house. Telephone 352-521-4545 (Dade City) 352-847-2411 (New Port Richey) or 1-800-955-8770 via Florida Relay Service.

DATED June 16, 2026. By: /s/ Lisa A. Woodburn Lisa A Woodburn Florida Bar No.: 11003 Roy Diaz, Attorney of Record Florida Bar No. 767700 Diaz Anselmo & Associates, P.A. Attorneys for Plaintiff 499 NW 70th Ave., Suite 309 Fort Lauderdale, FL 33317 Telephone: (954) 564-0071 Facsimile: (954) 564-9252 Service E-mail: answers@dallegal.com 1496-225870 / GSI June 26; July 3, 2026 26-01439P

FIRST INSERTION

NOTICE OF ACTION IN THE CIRCUIT COURT FOR THE SIXTH JUDICIAL CIRCUIT IN AND FOR PASCO COUNTY, FLORIDA CIRCUIT CIVIL DIVISION

CASE NO.: 2026CA000282CAAXWS U.S. BANK TRUST NATIONAL ASSOCIATION, Plaintiff(s), vs. CRAIG S TERRACE; SEVEN SPRINGS VILLAS ASSOCIATION, INC.; THE UNKNOWN SPOUSE OF CRAIG S TERRACE; THE UNKNOWN TENANT IN POSSESSION, Defendant(s).

TO: CRAIG S TERRACE LAST KNOWN ADDRESS: 3302 TROPHY BOULEVARD, UNIT 5, NEW PORT RICHEY, FL 34655 CURRENT ADDRESS: 3302 TROPHY BOULEVARD, UNIT 5, NEW PORT RICHEY, FL 34655 TO: THE UNKNOWN SPOUSE OF CRAIG S TERRACE LAST KNOWN ADDRESS: 3302 TROPHY BOULEVARD, UNIT 5, NEW PORT RICHEY, FL 34655 CURRENT ADDRESS: 3302 TROPHY BOULEVARD, UNIT 5, NEW PORT RICHEY, FL 34655

TO: THE UNKNOWN TENANT IN POSSESSION LAST KNOWN ADDRESS: 3302 TROPHY BOULEVARD, UNIT 5, NEW PORT RICHEY, FL 34655 CURRENT ADDRESS: 3302 TROPHY BOULEVARD, UNIT 5, NEW PORT RICHEY, FL 34655 TO: THE UNKNOWN TENANT IN POSSESSION LAST KNOWN ADDRESS: 3302 TROPHY BOULEVARD, UNIT 5, NEW PORT RICHEY, FL 34655 CURRENT ADDRESS: 3302 TROPHY BOULEVARD, UNIT 5, NEW PORT RICHEY, FL 34655

YOU ARE HEREBY NOTIFIED that a civil action has been filed against you in the Circuit Court of Pasco County, Florida, to foreclose certain real property described as follows:

UNIT 2405, SEVEN SPRINGS VILLAS, A CONDOMINIUM, UNIT ONE, ACCORDING TO THE DECLARATION OF CONDOMINIUM THEREOF AND A PERCENTAGE IN THE COMMON ELEMENTS APURTENANT THERETO AS RECORDED IN O.R. BOOK 685, PAGE 306, AND SUBSEQUENT AMENDMENTS

THERETO, AND AS RECORDED IN PLAT BOOK 11, PAGES 141 THROUGH 144, OF THE PUBLIC RECORDS OF PASCO COUNTY, FLORIDA.

Property address: 3302 Trophy Boulevard, Unit 5, New Port Richey, FL 34655

You are required to file a written response with the Court and serve a copy of your written defenses, if any, to it on Padgett Law Group, whose address is 6267 Old Water Oak Road, Suite 203, Tallahassee, FL 32312, at least thirty (30) days from the date of first publication, and file the original with the clerk of this court either before service on Plaintiff's attorney or immediately thereafter; otherwise, a default will be entered against you for the relief demanded in the complaint. Due on or before July 27th, 2026

If you are a person with a disability who needs an accommodation in order to participate in this proceeding, you are entitled, at no cost to you, to the provision of certain assistance. Please contact the Public Information Dept., Pasco County Government Center, 7530 Little Rd., New Port Richey, FL 34654; (727) 847-8110 (V) in New Port Richey; (352) 521-4274, ext 8110 (V) in Dade City, at least 7 days before your scheduled court appearance, or immediately upon receiving this notification if the time before the scheduled appearance is less than 7 days; if you are hearing impaired call 711. The court does not provide transportation and cannot accommodate for this service. Persons with disabilities needing transportation to court should contact their local public transportation providers for information regarding transportation services.

DATED this 17th day of June, 2026 CLERK OF THE CIRCUIT COURT As Clerk of the Court (SEAL) BY: Haley Joyner Deputy Clerk Plaintiff Atty: Padgett Law Group 6267 Old Water Oak Road, Suite 203 Tallahassee, FL 32312 attorney@padgettlawgroup.com TDP File No. 25-013940-1 June 26; July 3, 2026 26-01440P

FIRST INSERTION

NOTICE OF ACTION IN THE CIRCUIT COURT OF THE SIXTH JUDICIAL CIRCUIT IN AND FOR PASCO COUNTY, FLORIDA

CASE NO.: 2026CA001441CAAXWS NEWREZ LLC, Plaintiff, vs.

ALAN NORTON, AS PERSONAL REPRESENTATIVE OF THE ESTATE OF MARK NORTON A/K/A MARK A. NORTON, DECEASED; UNKNOWN HEIRS, DEVISEES, GRANTEES, LIENORS, TRUSTEES OF MARK NORTON A/K/A MARK A. NORTON, DECEASED; ALAN NORTON; VILLA DEL RIO HOMEOWNERS ASSOCIATION, INC.; UNKNOWN TENANT(S) IN POSSESSION #1 and #2, et al. Defendant(s).

TO: UNKNOWN HEIRS, DEVISEES, GRANTEES, ASSIGNEES, CREDITORS, LIENORS, TRUSTEES OF MARK NORTON A/K/A MARK A. NORTON, DECEASED (Current Residence Unknown) (Last Known Address) 9317 SANTA MONICA WAY NEW PORT RICHEY, FL 34655

ALL OTHER UNKNOWN PARTIES, INCLUDING, IF A NAMED DEFENDANT IS DECEASED, THE PERSONAL REPRESENTATIVES, THE SURVIVING SPOUSE, HEIRS, DEVISEES, GRANTEES, CREDITORS, AND ALL OTHER PARTIES CLAIMING, BY, THROUGH, UNDER OR AGAINST THAT DEFENDANT, AND ALL CLAIMANTS, PERSONS OR PARTIES, NATURAL OR CORPORATE, OR WHOSE EXACT LEGAL STATUS IS UNKNOWN, CLAIMING UNDER ANY OF THE ABOVE NAMED OR DESCRIBED DEFENDANTS (Last Known Address) 9317 SANTA MONICA WAY NEW PORT RICHEY, FL 34655 YOU ARE NOTIFIED that an action for Foreclosure of Mortgage on the following described property: LOT 24, VILLA DEL RIO - UNIT FOUR, ACCORDING TO THE

PLAT THEREOF, AS RECORDED IN PLAT BOOK 40, PAGE 43, OF THE PUBLIC RECORDS OF PASCO COUNTY, FLORIDA. A/K/A: 9317 SANTA MONICA WAY, NEW PORT RICHEY, FL 34655.

has been filed against you and you are required to serve a copy of your written defenses, if any, to it, on Brian L. Rosaler, Esquire, POPKIN & ROSALER, P.A., 1701 West Hillsboro Boulevard, Suite 400, Deerfield Beach, FL 33442., Attorney for Plaintiff, on or before 7/27/26, a date which is within thirty (30) days after the first publication of this Notice in the (Please publish in Business Observer) and file the original with the Clerk of this Court either before service on Plaintiff's attorney or immediately thereafter; otherwise a default will be entered against you for the relief demanded in the complaint.

If you are a person with a disability who needs an accommodation in order to participate in this proceeding, you are entitled, at no cost to you, to the provision of certain assistance. Please contact:

Public Information Dept., Pasco County Government Center 7530 Little Rd. New Port Richey, FL 34654 Phone: 727.847.8110 (voice) in New Port Richey 352.521.4274, ext 8110 (voice) in Dade City Or 711 for the hearing impaired

Contact should be initiated at least seven days before the scheduled court appearance, or immediately upon receiving this notification if the time before the scheduled appearance is less than seven days.

WITNESS my hand and the seal of this Court this JUN 23 2026. NIKKI ALVAREZ-SOWLES, ESQ. As Clerk of the Court and/or Comptroller /s/ Jasmine Gonzalez Deputy Clerk

Brian L. Rosaler, Esquire POPKIN & ROSALER, P.A. 1701 West Hillsboro Boulevard, Suite 400 Deerfield Beach, FL 33442 Attorney for Plaintiff 26-52965 June 26; July 3, 2026 26-01477P



## --- ESTATE ---

## SECOND INSERTION

**NOTICE TO CREDITORS**  
IN THE CIRCUIT COURT OF THE  
SIXTH JUDICIAL CIRCUIT IN AND  
FOR PASCO COUNTY, FLORIDA—  
PROBATE DIVISION  
Case No.: 2026-CP-333  
IN RE: The Estate of  
MARIA M. GARCIA a/k/a  
MARIA GARCIA a/k/a  
MARIA MARGARITA GARCIA  
a/k/a MARGARET MOLINA a/k/a  
MARIA MARGARITA MOLINA a/k/a  
MARIA MARGARITA ADORNO,  
Deceased.

The administration of the Estate of MARIA M. GARCIA, deceased, whose date of death was October 13, 2025, is pending in the Circuit Court for Pasco County, Florida, Probate Division, the address of which is 7530 Little Road, New Port Richey, Florida 34654. The names and addresses of the Personal Representative and the Personal Representative's attorney are set forth below.

All creditors of the decedent and other persons having claims or demands against decedent's estate on whom a copy of this notice is required to be served must file their claims with this court ON OR BEFORE THE LATER OF 3 MONTHS AFTER THE TIME OF THE FIRST PUBLICATION OF THIS NOTICE OR 30 DAYS AFTER THE DATE OF SERVICE OF A COPY OF THIS NOTICE ON THEM.

All other creditors of the decedent and other persons having claims or demands against decedent's estate must file their claims with this court WITHIN 3 MONTHS AFTER THE DATE OF THE FIRST PUBLICATION OF THIS NOTICE.

ALL CLAIMS NOT FILED WITHIN THE TIME PERIODS SET FORTH IN FLORIDA STATUTES SECTION 733.702 WILL BE FOREVER BARRED.

NOTWITHSTANDING THE TIME PERIODS SET FORTH ABOVE, ANY CLAIM FILED TWO (2) YEARS OR MORE AFTER THE DECEDENT'S DATE OF DEATH IS BARRED.

The date of first publication of this notice is June 19, 2026.

**MARIO ESTUARDO GARCIA**  
Personal Representative  
15724 Puckett Road  
Dade City, FL 33525  
MONICA S. SANTANA, ESQ.  
Attorney for Personal Representative  
Florida Bar Number: 956805  
Of Counsel to Robles Law, P.A.  
7729 Holiday Drive  
Sarasota, FL 34231  
Telephone: (941) 3152114  
Fax: (941) 8272988  
E-Mail: monica@robleslawpa.com  
Secondary E-Mail:  
probate@robleslawpa.com  
June 19, 26, 2026 26-01423P

## SECOND INSERTION

**NOTICE OF FORECLOSURE SALE**  
IN THE CIRCUIT COURT OF  
THE SIXTH JUDICIAL CIRCUIT,  
IN AND FOR PASCO COUNTY,  
FLORIDA  
CASE NO.  
2025CA001728CAAXES

**LAKEVIEW LOAN SERVICING,  
LLC,**  
Plaintiff, vs.

**CINDY DE LA ROSA;**  
Defendants

NOTICE IS HEREBY GIVEN pursuant to a Uniform Final Judgment of Foreclosure dated May 15, 2026, and entered in Case No. 2025CA001728CAAXES, of the Circuit Court of the Sixth Judicial Circuit in and for PASCO County, Florida. LAKEVIEW LOAN SERVICING, LLC (hereafter "Plaintiff"), is Plaintiff and CINDY DE LA ROSA; are defendants. Nikki Alvarez-Sowles, Esq., Clerk of the Circuit Court for PASCO, County Florida will sell to the highest and best bidder for cash via the Internet at www.pasco.realforeclose.com, at 11:00 a.m., on the 14TH day of JULY, 2026, the following described property as set forth in said Final Judgment, to wit:

LOT 1, HIGHLAND MEADOWS LOT 56, MEADOW POINTE PARCEL 15 UNIT 2 REPLAT, ACCORDING TO THE MAP OR PLAT THEREOF, AS RECORDED IN PLAT BOOK 41, PAGE(S) 141, OF THE PUBLIC RECORDS OF PASCO COUNTY, FLORIDA.

If you are a person with a disability who needs any accommodation in order to participate in this proceeding, you are entitled, at no cost to you, to the provision of certain assistance. Please contact either the Pasco County Customer Service Center, 8731 Citizens Drive, New Port Richey, FL 34654, (727) 847-2411 (V) or the Pasco County Risk Management Office, 7536 State Street, New Port Richey, FL 34654, (727) 847-8028 (V) at least 7 days before your scheduled court appearance, or immediately upon receiving this notification if the time before the scheduled appearance is less than 7 days; if you are hearing or voice impaired, call 711.

## SECOND INSERTION

**NOTICE TO CREDITORS**  
IN THE CIRCUIT COURT OF THE  
SIXTH JUDICIAL CIRCUIT IN AND  
FOR PASCO COUNTY, FLORIDA  
PROBATE DIVISION  
Case No.: 2026-CP-000895-WS  
IN RE: ESTATE OF  
SUSAN PETA JONES,  
DECEASED.

The administration of the estate of SUSAN PETA JONES, deceased, whose date of death was February 1, 2026, is pending in the Circuit Court for Pasco County, Florida, Probate Division; File Number 2026-CP-000895-WS; the address of which is 7530 Little Road, New Port Richey, FL 34654. The names and addresses of the personal representative(s) and the personal representative(s)' attorney are set forth below. The Fiduciary lawyer-client privilege in s. 90.5021 FLA. STAT. applies with respect to the personal representative and any attorney employed by the personal representative.

All creditors of the decedent and other persons, who have claims or demands against decedent's estate, including unmaturing, contingent or unliquidated claims, and who have been served a copy of this notice, must file their claims with this court WITHIN THE LATER OF THREE (3) MONTHS AFTER THE DATE OF THE FIRST PUBLICATION OF THIS NOTICE OR THIRTY (30) DAYS AFTER THE DATE OF SERVICE OF A COPY OF THIS NOTICE ON THEM.

All other creditors of the decedent and other persons who have claims or demands against the decedent's estate, including unmaturing, contingent or unliquidated claims, must file their claims with this court WITHIN THREE (3) MONTHS AFTER THE DATE OF THE FIRST PUBLICATION OF THIS NOTICE.

ALL CLAIMS NOT SO FILED WILL BE FOREVER BARRED.

NOTWITHSTANDING THE TIME PERIODS SET FORTH ABOVE, ANY CLAIM FILED TWO (2) YEARS OR MORE AFTER THE DECEDENT'S DATE OF DEATH IS BARRED.

THE DATE OF FIRST PUBLICATION OF THIS NOTICE IS JUNE 19, 2026

**PETITIONER:  
LYNN MARTENS**  
12061 Darwin Avenue  
New Port Richey, FL 34654  
ATTORNEY FOR  
PERSONAL REPRESENTATIVE:  
CARRIE N. FELICE, ESQ.  
Florida Bar No.: 0014292  
ELDER NEEDS LAW, PLLC  
14391 Spring Hill Drive, Suite 287  
Spring Hill, FL 34609  
Telephone: (352)204-9611  
carrie@elderneedslaw.com  
probateenl@gmail.com  
June 19, 26, 2026 26-01371P

Si usted es una persona minusválida que necesita algún acomodamiento para poder participar en este procedimiento, usted tiene derecho, sin tener gastos propios, a que se le provea cierta ayuda. Tenga la amabilidad de ponerse en contacto con Pasco County Customer Service Center, 8731 Citizens Drive, New Port Richey, FL 34654, (727) 847-2411 (V) or Pasco County Risk Management Office, 7536 State Street, New Port Richey, FL 34654, (727) 847-8028 (V) por lo menos 7 días antes de la cita fijada para su comparecencia en los tribunales, o inmediatamente después de recibir esta notificación si el tiempo antes de la comparecencia que se ha programado es menos de 7 días; si usted tiene discapacidad del oído o de la voz, llame al 711.

Si you se yon moun ki enfim ki bezwen akomodasyon pou w ka patisipe nan pwosedi sa, ou kalifye san ou pa gen okenn lajan pou w peye, gen pwovizyon pou jwen kek ed. Tanpri kontakte Pasco County Customer Service Center, 8731 Citizens Drive, New Port Richey, FL 34654, (727) 847-2411 (V) or Pasco County Risk Management Office, 7536 State Street, New Port Richey, FL 34654, (727) 847-8028 (V) nan 7 jou anvan dat ou gen randevou pou parèt nan tribinal la, oubyen imedyatman apre ou fin resevwa konvokasyon an si lè ou gen pou w parèt nan tribinal la mwens ke 7 jou; si ou gen pwoblèm pou w tande oubyen pale, rele 711.

Any person claiming an interest in the surplus from the sale, if any, other than the property owner as of the date of the lis pendens must file a claim before the clerk reports the surplus as unclaimed.

/s/ J. Anthony Van Ness  
J. Anthony Van Ness, Esq.  
Bar Number: 391832  
VAN NESS LAW FIRM, PLC  
1239 E. Newport Center Drive,  
Suite 110  
Deerfield Beach, Florida 33442  
Ph: (954) 571-2031  
PRIMARY EMAIL:  
Pleadings@vanlawfl.com  
RM20697-25NS/sap  
June 19, 26, 2026 26-01376P

## SECOND INSERTION

**NOTICE TO CREDITORS**  
IN THE CIRCUIT COURT OF THE  
SIXTH JUDICIAL CIRCUIT IN AND  
FOR PASCO COUNTY, FLORIDA  
PROBATE DIVISION  
File No.: 2026-CP-000648  
IN RE: ESTATE OF  
LAWONNA L. WOODY  
Deceased.

The administration of the Estate of LAWONNA L. WOODY, deceased, whose date of death was January 12, 2026, is pending in the Circuit Court for Pasco County Florida, Probate Division, the address of which is West Pasco Judicial Center, 7530 Little Road, New Port Richey, Florida 34654, under File No.: 2026-CP-000648. The name and address of the personal representative and the personal representative's attorney are set forth below. The first publication of this Notice is on June 19, 2026.

All creditors of the decedent and other persons having claims or demands against the decedent's estate, on whom a copy of this Notice is required to be served must file their claims with this Court, WITHIN THE LATER OF THREE (3) MONTHS AFTER THE DATE OF THE FIRST PUBLICATION OF THIS NOTICE OR WITHIN THIRTY (30) DAYS AFTER THE DATE OF SERVICE OF A COPY OF THIS NOTICE ON THEM.

All other creditors of the decedent and other persons having claims or demands against decedent's estate must file their claims with this court WITHIN THREE (3) MONTHS AFTER THE DATE OF THE FIRST PUBLICATION OF THIS NOTICE.

ALL CLAIMS NOT SO FILED WILL BE FOREVER BARRED.

NOTWITHSTANDING THE TIME PERIOD SET FORTH ABOVE, ANY CLAIM FILED TWO (2) YEARS OR MORE AFTER THE DECEDENT'S DATE OF DEATH IS BARRED.

The personal representative or curator has no duty to discover whether any property held at the time of the decedent's death by the decedent or the decedent's surviving spouse, is property to which the Florida Uniform Disposition of Community Property Rights at Death Act as described in sections 732.216-732.228, Florida Statutes, applies or may apply, unless a written demand is made by a creditor as specified under section 732.221, Florida Statute.

Dated: June 8, 2026.  
**Christina Scull /s/  
Christina Scull,**  
Personal Representative  
c/o Paul J. Bupivi, Esq.  
330 S. Pineapple Avenue, Suite 110  
Sarasota, Florida 34236  
Tel.: (941) 404-6360  
Paul J. Bupivi, Esq. (FL Bar #94635)  
Attorney for the Personal  
Representative  
330 S. Pineapple Avenue, Suite 110  
Sarasota, Florida 34236  
Tel.: (941) 404-6360  
Email: paul@bupivilaw.com  
June 19, 26, 2026 26-01377P

## SECOND INSERTION

**NOTICE OF SALE**  
IN THE CIRCUIT COURT OF THE  
6TH JUDICIAL CIRCUIT IN AND  
FOR PASCO COUNTY, FLORIDA

**CASE NO.: 2025CA004039CAAXES**  
**CARRINGTON MORTGAGE**  
**SERVICES LLC,**  
Plaintiff, vs.

**CHRISTINE T. BOCANFUSO**  
**A/K/A CHRISTINE BOCANFUSO;**  
**UNKNOWN SPOUSE OF**  
**CHRISTINE T. BOCANFUSO A/K/A**  
**CHRISTINE BOCANFUSO; THE**  
**GROVES GOLF & COUNTRY CLUB**  
**MASTER ASSOCIATION, INC.;**  
**UNITED STATES OF AMERICA**  
**ON BEHALF OF THE SECRETARY**  
**OF HOUSING AND URBAN**  
**DEVELOPMENT,**  
Defendant(s).

NOTICE OF SALE IS HEREBY GIVEN pursuant to the order of Uniform Final Judgment of Foreclosure dated June 5, 2026, and entered in Case No. 2025CA004039CAAXES of the Circuit Court of the 6TH Judicial Circuit in and for Pasco County, Florida, wherein Carrington Mortgage Services LLC, is Plaintiff and Christine T. Bocanfuso a/k/a Christine Bocanfuso; Unknown Spouse of Christine T. Bocanfuso a/k/a Christine Bocanfuso; The Groves Golf & Country Club Master Association, Inc.; United States of America on behalf of the Secretary of Housing and Urban Development, are Defendants, the Office of the Clerk of Nikki Alvarez-Sowles, Esq., Pasco County Clerk of the Court will sell via online auction at www.pasco.realforeclose.com at 11:00 A.M. on the 4th day of August, 2026, the following described property as set forth in said Final Judgment, to wit:

LOT 17, BLOCK AB, GROVES PHASE 1A, A SUBDIVISION

ACCORDING TO THE PLAT THEREOF RECORDED AT PLAT BOOK 39, PAGES 120 THROUGH 150, IN THE PUBLIC RECORDS OF PASCO COUNTY, FLORIDA.  
Property Address: 20845 Eustis Road, Land O Lakes, Florida 34637  
and all fixtures and personal property located therein or thereon, which are included as security in Plaintiff's mortgage.

Any person claiming an interest in the surplus funds from the sale, if any, other than the property owner as of the date of the lis pendens must file a claim before the clerk reports the surplus as unclaimed.  
If you are a person with a disability who needs any accommodation in order to participate in this proceeding, you are entitled, at no cost to you, to the provision of certain assistance. Please contact the Pasco County Human Resources Office, 8731 Citizens Drive, Suite 330, New Port Richey FL 34654, (727) 847-8103 (V) at least 7 days before your scheduled court appearance, or immediately upon receiving this notification if the time before the scheduled appearance is less than 7 days; if you are hearing or voice impaired, call 711.  
Dated: 6/12/2026  
McCabe, Weisberg & Conway, LLC  
By: /s/ Craig Stein  
Craig Stein, Esq.  
Fl Bar No. 0120464  
McCabe, Weisberg & Conway, LLC  
3222 Commerce Place, Suite A  
West Palm Beach, Florida, 33407  
Telephone: (561) 713-1400  
Email: FLpleadings@mwc-law.com  
File No: 25-400672  
June 19, 26, 2026 26-01392P

## SECOND INSERTION

**NOTICE TO CREDITORS**  
IN THE CIRCUIT COURT IN AND  
FOR PASCO COUNTY, FLORIDA  
PROBATE DIVISION  
File No. 2026 CP 000977CPAXES  
IN RE: ESTATE OF  
ANDREW EARL BARNES,  
Deceased.

The administration of the estate of ANDREW EARL BARNES, deceased, whose date of death was April 23, 2026, is pending in the Circuit Court for Pasco County, Florida, Probate Division, the address of which is 38053 Live Oak Avenue, Dade City, FL 33523. The names and addresses of the personal representative and the personal representative's attorney are set forth below.

All creditors of the decedent and other persons having claims or demands against decedent's estate on whom a copy of this notice is required to be served must file their claims with this court ON OR BEFORE THE LATER OF 3 MONTHS AFTER THE TIME OF THE FIRST PUBLICATION OF THIS NOTICE OR 30 DAYS AFTER THE DATE OF SERVICE OF A COPY OF THIS NOTICE ON THEM.

All other creditors of the decedent and other persons having claims or demands against decedent's estate must file their claims with this court WITHIN 3 MONTHS AFTER THE DATE OF THE FIRST PUBLICATION OF THIS NOTICE.

The personal representative has no duty to discover whether any property held at the time of the decedent's death by the decedent or the decedent's surviving spouse is property to which the Florida Uniform Disposition of Community Property Rights at Death Act as described in ss. 732.216-732.228, Florida Statutes, applies, or may apply, unless a written demand is made by a creditor as specified under s. 732.221, Florida Statutes. The written demand must be filed with the clerk.

ALL CLAIMS NOT FILED WITHIN THE TIME PERIODS SET FORTH IN FLORIDA STATUTES SECTION 733.702 WILL BE FOREVER BARRED.

NOTWITHSTANDING THE TIME PERIODS SET FORTH ABOVE, ANY CLAIM FILED TWO (2) YEARS OR MORE AFTER THE DECEDENT'S DATE OF DEATH IS BARRED.

The date of first publication of this notice is June 19, 2026.

**Personal Representative:  
Elizabeth C. Barnes**  
Petitioner  
15724 Puckett Road  
Dade City, FL 33525  
Attorney for Personal Representative:  
Sidney Werner, Esq.  
Attorney for Petitioner  
Florida Bar Number: 203246  
BASKIN EISEL RIGHTMYER  
450 Carillon Pkwy, Suite 150  
St. Petersburg, FL 33716  
Telephone: (727) 572-4545  
Fax: (727) 572-4646  
E-Mail: swerner@baskineisel.com  
Secondary E-Mail:  
kelly@baskineisel.com  
June 19, 26, 2026 26-01407P

## SECOND INSERTION

**NOTICE TO CREDITORS**  
IN THE CIRCUIT COURT FOR  
PASCO COUNTY, FLORIDA  
PROBATE DIVISION  
File No. 51-2026-CP-000349-WS  
IN RE: ESTATE OF  
DONALD L. JENKINS, JR a/k/a  
DONALD LAMAR JENKINS, JR  
Deceased.

The administration of the estate of DONALD L. JENKINS, JR a/k/a DONALD LAMAR JENKINS, JR, deceased, whose date of death was November 29, 2025, is pending in the Circuit Court for Pasco County, Florida, Probate Division, the address of which is 7530 Little Road, New Port Richey, FL 34654. The names and addresses of the personal representative and the personal representative's attorney are set forth below.

All creditors of the decedent and other persons having claims or demands against decedent's estate on whom a copy of this notice is required to be served must file their claims with this court ON OR BEFORE THE LATER OF 3 MONTHS AFTER THE TIME OF THE FIRST PUBLICATION OF THIS NOTICE OR 30 DAYS AFTER THE DATE OF SERVICE OF A COPY OF THIS NOTICE ON THEM.

The personal representative has no duty to discover whether any property held at the time of the decedent's death by the decedent or the decedent's surviving spouse is property to which the Florida Uniform Disposition of Community Property Rights at Death Act as described in ss. 732.216-732.228, Florida Statutes, applies, or may apply, unless a written demand is made by a creditor as specified under s. 732.221, Florida Statutes. The written demand must be filed with the clerk.

All other creditors of the decedent and other persons having claims or demands against decedent's estate must file their claims with this court WITHIN 3 MONTHS AFTER THE DATE OF THE FIRST PUBLICATION OF THIS NOTICE.

ALL CLAIMS NOT FILED WITHIN THE TIME PERIODS SET FORTH IN FLORIDA STATUTES SECTION 733.702 WILL BE FOREVER BARRED.

NOTWITHSTANDING THE TIME PERIODS SET FORTH ABOVE, ANY CLAIM FILED TWO (2) YEARS OR MORE AFTER THE DECEDENT'S DATE OF DEATH IS BARRED.

The date of first publication of this notice is June 19, 2026.

**Personal Representative:  
Donald L. Jenkins III**  
7 Board Run Rd.  
Newport, Pennsylvania 17074  
Attorney for Personal Representative:  
DONALD R. PEYTON  
Attorney  
Florida Bar Number: 516619  
7317 Little Road  
New Port Richey, FL 34654  
Telephone: (727) 848-5997  
Fax: (727) 848-4072  
E-Mail: peytonlaw@yahoo.com  
Secondary E-Mail:  
peytonlaw2@gmail.com  
June 19, 26, 2026 26-01378P

## SECOND INSERTION

**NOTICE TO CREDITORS**  
IN THE CIRCUIT COURT FOR  
PASCO COUNTY, FLORIDA  
PROBATE DIVISION  
File No. 512026CP000745CPAXES  
Division I  
IN RE: ESTATE OF  
MARSHA HAGAR COLLEY,  
a/k/a MARSHA H. COLLEY  
Deceased.

The administration of the estate of MARSHA HAGAR COLLEY, a/k/a MARSHA H. COLLEY, deceased, whose date of death was March 28, 2026, is pending in the Circuit Court for Pasco County, Florida, Probate Division, the address of which is Robert D. Sumner Judicial Center, 38053 Live Oak Avenue, Dade City, FL 33523. The names and addresses of the personal representative and the personal representative's attorney are set forth below.

All creditors of the decedent and other persons having claims or demands against decedent's estate on whom a copy of this notice is required to be served must file their claims with this court ON OR BEFORE THE LATER OF 3 MONTHS AFTER THE TIME OF THE FIRST PUBLICATION OF THIS NOTICE OR 30 DAYS AFTER THE DATE OF SERVICE OF A COPY OF THIS NOTICE ON THEM.

All other creditors of the decedent and other persons having claims or demands against decedent's estate must file their claims with this court WITHIN 3 MONTHS AFTER THE DATE OF THE FIRST PUBLICATION OF THIS NOTICE.

The personal representative has no duty to discover whether any property held at the time of the decedent's death by the decedent or the decedent's surviving spouse is property to which the Florida Uniform Disposition of Community Property Rights at Death Act as described in ss. 732.216-732.228, Florida Statutes, applies, or may apply, unless a written demand is made by a creditor as specified under s. 732.221, Florida Statutes. The written demand must be filed with the clerk.

All other creditors of the decedent and other persons having claims or demands against decedent's estate must file their claims with this court WITHIN 3 MONTHS AFTER THE DATE OF THE FIRST PUBLICATION OF THIS NOTICE.

ALL CLAIMS NOT FILED WITHIN THE TIME PERIODS SET FORTH IN FLORIDA STATUTES SECTION 733.702 WILL BE FOREVER BARRED.

NOTWITHSTANDING THE TIME PERIODS SET FORTH ABOVE, ANY CLAIM FILED TWO (2) YEARS OR MORE AFTER THE DECEDENT'S DATE OF DEATH IS BARRED.

The date of first publication of this notice is June 19, 2026.

**Personal Representative:  
JAMA COLLEY KARL**  
38323 Honeysuckle Drive  
Dade City, FL 33525  
Attorney for Personal Representative:  
STEPHEN D. CARLE  
Florida Bar Number: 0213187  
HODGES & CARLE, P.A.  
38410 North Avenue  
P. O. Box 548  
Zephyrhills, FL 33539-0548  
Telephone: (813) 782-7196  
Fax: (813) 782-1026  
E-Mail: hodgescarle@hotmail.com  
June 19, 26, 2026 26-01397P

## SECOND INSERTION

**NOTICE TO CREDITORS**  
IN THE CIRCUIT COURT FOR  
PASCO COUNTY, FLORIDA  
PROBATE DIVISION  
File No. 2026-CP-907  
IN RE: ESTATE OF  
KENNETH WAYT AKA  
KENNETH E. WAYT  
Deceased.

The administration of the estate of KENNETH WAYT AKA KENNETH E. WAYT, deceased, whose date of death was April 22, 2026, is pending in the Circuit Court for Pasco County, Florida, Probate Division, the address of which is P.O. Drawer 338, New Port Richey, FL 34656-0338. The names and addresses of the personal representative and the personal representative's attorney are set forth below.

All creditors of the decedent and other persons having claims or demands against decedent's estate on whom a copy of this notice is required to be served must file their claims with this court ON OR BEFORE THE LATER OF 3 MONTHS AFTER THE TIME OF THE FIRST PUBLICATION OF THIS NOTICE OR 30 DAYS AFTER THE DATE OF SERVICE OF A COPY OF THIS NOTICE ON THEM.

All other creditors of the decedent and other persons having claims or demands against decedent's estate must file their claims with this court WITHIN 3 MONTHS AFTER THE DATE OF THE FIRST PUBLICATION OF THIS NOTICE.

The personal representative has no duty to discover whether any property held at the time of the decedent's death

by the decedent or the decedent's surviving spouse is property to which the Florida Uniform Disposition of Community Property Rights at Death Act as described in ss. 732.216-732.228, Florida Statutes, applies, or may apply, unless a written demand is made by a creditor as specified under s. 732.221, Florida Statutes. The written demand must be filed with the clerk.

ALL CLAIMS NOT FILED WITHIN THE TIME PERIODS SET FORTH IN FLORIDA STATUTES SECTION 733.702 WILL BE FOREVER BARRED.

NOTWITHSTANDING THE TIME PERIODS SET FORTH ABOVE, ANY CLAIM FILED TWO (2) YEARS OR MORE AFTER THE DECEDENT'S DATE OF DEATH IS BARRED.

The date of first publication of this notice is June 19, 2026.

**Personal Representative:  
ELIZABETH E. SCHIBER**  
9650 Feather Wood Lane  
Centerville, Ohio 45458  
Attorney for Personal Representative:  
/S/CHRISTINA KANE  
CHRISTINA KANE  
Attorney  
Florida Bar Number: 97970  
LYONS LAW GROUP PA  
8362 FOREST OAKS BLVD  
Spring Hill, FL 34606  
Telephone: (352) 515-0101  
Fax: (352) 616-0055  
E-Mail:  
ckane@lyonslawgroup.com  
Secondary E-Mail:  
cynidi@lyonslawgroup.com  
June 19, 26, 2026 26-01406P

## --- SALES / ACTIONS ---

## THIRD INSERTION

**AMENDED NOTICE OF ACTION IN THE CIRCUIT COURT OF THE SIXTH JUDICIAL CIRCUIT IN AND FOR PASCO COUNTY, FLORIDA CIVIL DIVISION**

Case No.:

**512026CA000472CAAXES RYAN COMPANIES US, INC., a Minnesota corporation****Plaintiff, v.**

**JOHN K. KEYES; REUBEN BROOKS; DR. A.H. McCOY; ROBERT A. HERSCHBACH; RAYMOND A. WILLIAMS, JR.; RUDMAN RESOURCES, INC., a Texas corporation; J. COLLINS WOHLER; ARDEN A. ANDERSON; MAURINE GENECOV MUNTZ; EMMETTE F. GATHRIGHT; HAYWOOD HANNA, JR.; E.G. STONE and MARYANN STONE; HAROLD M. WARD, AS TRUSTEE FOR ELAINE C. WARD, HAROLD C. WARD AND THOMAS G. WARD; HARRY C. TEAGUE and NELL R. TEAGUE, husband and wife; PLAZA PARK, INC., an involuntarily dissolved Florida corporation; LISA SUZANNE HALE, formerly known as LISA SUZANNE TEAGUE; GEORGE COURY, AS TRUSTEE FOR MAUREEN CURRAN BELL, PATRICK WILLIAM BELL, JR., COURY JAMAIL BELL AND JOSEPH COURY LAWRENCE; PATRICIA LAWRENCE; GLENN H. BRACKEN; JEFF M. BRACKEN; SAM T. BRACKEN; A.Y. LEWIS; IDA BRACKEN LEWIS; ADDIE BRACKEN PRICE; ADDIE BRACKEN PRICE, TRUSTEE FOR JOHN PAUL PRICE TRUST NO. 4; ADDIE BRACKEN PRICE, TRUSTEE FOR SALLY SUE PRICE TRUST NO. 4; J. BRADLEY JEFFREYS; JAMES LILLY, TRUSTEE; BEN E. SUTTON AND ELIZABETH T. SUTTON; MOODY H. DAVIS and PATRICIA H. DAVIS; THOMAS G. THOMPSON; ROY T. ANDERSON, TRUSTEE OF THE ROY T. ANDERSON TRUST U/A DATED DECEMBER 5, 1989; COWAN MINERALS, INC., a Texas corporation; LAWRENCE CONSOLIDATED ENTERPRISES, LTD., a Texas limited partnership; MARTHA KATHRYN LEWIS MARSHALL; NANCY I. GEIGER f/k/a NANCY I. GRANTHAM; BLAIRBAX ENERGY, LLC, a Texas limited liability company; BAXSTO, LLC, a Texas limited liability company; BUFFY ENERGY, LLC, a Texas limited liability company; THE MR TRUST; RUDMAN FAMILY TRUST; JOHN K. KEYES FAMILY TRUST; ROBERT S. DIX; HAROLD M. WARD and MARGARET C. WARD, husband and wife; HAYWOOD HANNA, JR., and JULIA B. HANNA, husband and wife; GENEVIEVE E. CROOKS; FVPRTAV, LLC, a Texas limited liability company; E3 LAND & MINERALS, LLC, a Texas limited liability company; CJKJ INVESTMENTS, LLC, a Texas limited liability company; SOURCE MINERALS, LLC, a Texas limited liability company; RWTL, LLC, a Texas limited liability company; JENCO LAND, LLC, a Texas limited liability company, and all unknown persons, if alive, and if dead, or not known to be dead or alive, their respective unknown spouses, heirs, devisees, grantees, assignees, lienors, creditors, trustees or other persons claiming by, through, under or against the above Defendants, Defendants.**

TO: Defendants, JOHN K. KEYES, if alive, and if dead, his unknown spouses, heirs, devisees, grantees, assignees, lienors, creditors, trustees or other persons claiming by, through, under

or against JOHN K. KEYES; REUBEN BROOKS, if alive, and if dead, his unknown spouses, heirs, devisees, grantees, assignees, lienors, creditors, trustees or other persons claiming by, through, under or against REUBEN BROOKS; DR. A.H. McCOY, if alive, and if dead, his unknown spouses, heirs, devisees, grantees, assignees, lienors, creditors, trustees or other persons claiming by, through, under or against DR. A.H. McCOY; ROBERT A. HERSCHBACH, if alive, and if dead, his unknown spouses, heirs, devisees, grantees, assignees, lienors, creditors, trustees or other persons claiming by, through, under or against RAYMOND A. WILLIAMS, JR.; RUDMAN RESOURCES, INC., a Texas corporation; MAURINE GENECOV MUNTZ, if alive, and if dead, her unknown spouses, heirs, devisees, grantees, assignees, lienors, creditors, trustees or other persons claiming by, through, under or against MAURINE GENECOV MUNTZ; EMMETTE F. GATHRIGHT, if alive, and if dead, his unknown spouses, heirs, devisees, grantees, assignees, lienors, creditors, trustees or other persons claiming by, through, under or against EMMETTE F. GATHRIGHT; HAYWOOD HANNA, JR., if alive, and if dead, his unknown spouses, heirs, devisees, grantees, assignees, lienors, creditors, trustees or other persons claiming by, through, under or against HAYWOOD HANNA, JR.; E.G. STONE and MARYANN STONE, if alive, and if dead, their unknown spouses, heirs, devisees, grantees, assignees, lienors, creditors, trustees or other persons claiming by, through, under or against HAYWOOD HANNA, JR.; E.G. STONE and MARYANN STONE; HAROLD M. WARD, AS TRUSTEE FOR ELAINE C. WARD, HAROLD C. WARD AND THOMAS G. WARD, if alive, and if dead, their unknown spouses, heirs, devisees, grantees, assignees, lienors, creditors, trustees or other persons claiming by, through, under or against HARRY C. TEAGUE and NELL R. TEAGUE, husband and wife; GEORGE COURY, AS TRUSTEE FOR MAUREEN CURRAN BELL, PATRICK WILLIAM BELL, JR., COURY JAMAIL BELL AND JOSEPH COURY LAWRENCE, if alive, and if dead, their unknown spouses, heirs, devisees, grantees, assignees, lienors, creditors, trustees or other persons claiming by, through, under or against GLENN H. BRACKEN; JEFF M. BRACKEN, if alive, and if dead, his unknown spouses, heirs, devisees, grantees, assignees, lienors, creditors, trustees or other persons claiming by, through, under or against SAM T. BRACKEN;

A.Y. LEWIS, if alive, and if dead, his/her unknown spouses, heirs, devisees, grantees, assignees, lienors, creditors, trustees or other persons claiming by, through, under or against A.Y. LEWIS; IDA BRACKEN LEWIS, if alive, and if dead, her unknown spouses, heirs, devisees, grantees, assignees, lienors, creditors, trustees or other persons claiming by, through, under or against ADDIE BRACKEN PRICE, TRUSTEE FOR JOHN PAUL PRICE TRUST NO. 4, if alive, and if dead, her unknown spouses, heirs, devisees, grantees, assignees, lienors, creditors, trustees or other persons claiming by, through, under or against ADDIE BRACKEN PRICE, TRUSTEE FOR SALLY SUE PRICE TRUST NO. 4, if alive, and if dead, her unknown spouses, heirs, devisees, grantees, assignees, lienors, creditors, trustees or other persons claiming by, through, under or against ADDIE BRACKEN PRICE, TRUSTEE FOR JOHN PAUL PRICE TRUST NO. 4; ADDIE BRACKEN PRICE, TRUSTEE FOR SALLY SUE PRICE TRUST NO. 4, if alive, and if dead, her unknown spouses, heirs, devisees, grantees, assignees, lienors, creditors, trustees or other persons claiming by, through, under or against ADDIE BRACKEN PRICE, TRUSTEE FOR JOHN PAUL PRICE TRUST NO. 4; ROY T. ANDERSON, TRUSTEE OF THE ROY T. ANDERSON TRUST U/A DATED DECEMBER 5, 1989, if alive, and if dead, his unknown spouses, heirs, devisees, grantees, assignees, lienors, creditors, trustees or other persons claiming by, through, under or against ROY T. ANDERSON, TRUSTEE OF THE ROY T. ANDERSON TRUST U/A DATED DECEMBER 5, 1989; BAXSTO, LLC, a Texas limited liability company; JOHN K. KEYES FAMILY TRUST; ROBERT S. DIX, if alive, and if dead, his unknown spouses, heirs, devisees, grantees, assignees, lienors, creditors, trustees or other persons claiming by, through, under or against HAYWOOD HANNA, JR., and JULIA B. HANNA, husband and wife, if alive, and if dead, their unknown spouses, heirs, devisees, grantees, assignees, lienors, creditors, trustees or other persons claiming by, through, under or against HAROLD M. WARD and MARGARET C. WARD, husband and wife; HAYWOOD HANNA, JR., and JULIA B. HANNA, husband and wife, if alive, and if dead, their unknown spouses, heirs, devisees, grantees, assignees, lienors, creditors, trustees or other persons claiming by, through, under or against GENEVIEVE E. CROOKS; SOURCE MINERALS, LLC, a Texas limited liability company; and all unknown persons, if alive, and if dead, or not known to be dead or alive, their unknown spouses, heirs, devisees, grantees, assignees, lienors, creditors, trustees or other persons claiming by, through, under or against the above-named Defendants (collectively, "Unknown Defendants"), and all unknown persons, if alive, and if dead, or not known to be dead or alive, their unknown spouses, heirs, devisees, grantees, assignees, lienors, creditors, trustees or other persons claiming by, through, under or against the unknown persons, and others, and, and all other parties having or claiming to have any right, title or interest in the real property herein described.

YOU ARE HEREBY NOTIFIED that a Verified Complaint for Partition of Mineral Interests relating to certain real property located in Pasco County,

Florida, to-wit: SEE EXHIBIT A ATTACHED HERETO AND MADE A PART HEREOF, has been filed against you and you are required to serve a copy of your written defenses, if any, to Plaintiff's attorney, LEONARD H. JOHNSON, ESQUIRE, and SHEADA MADANI, ESQUIRE of the law firm of JOHNSON POPE BOKOR RUPPEL & BURNS LLP, whose address is 400 North Ashley Drive, Suite 3100, Tampa, Florida 33602, lenj@jppfirm.com or sheadam@jppfirm.com, telephone number (813) 225-2500, attorneys for the Plaintiff, RYAN COMPANIES US, INC., a Minnesota corporation, on or before JULY 13, 2026, and file the original with the Clerk of this Court either before service on the Plaintiff's attorney or immediately thereafter; otherwise a default will be entered against you for the relief demanded in the Verified Complaint for Partition of Mineral Interests.

## EXHIBIT A

THE LAND REFERRED TO HEREIN BELOW IS SITUATED IN THE COUNTY OF PASCO, STATE OF FLORIDA, AND IS DESCRIBED AS FOLLOWS: COMMENCE AT THE SOUTHEAST CORNER OF THE SOUTHWEST 1/4 OF SECTION 29, TOWNSHIP 25 SOUTH, RANGE 20 EAST, PASCO COUNTY, FLORIDA, FOR A POINT OF BEGINNING, THENCE WEST ALONG THE SOUTH LINE OF SAID SECTION 29, 1744.01 FEET; THENCE N09°50'00"E, 1175.0 FEET; THENCE S81°30'00"E, 764.72 FEET; THENCE N74°24'00"E, 372.50 FEET; THENCE S49°41'E, 558.51 FEET (D) (558.55 FEET FIELD), TO THE EAST LINE OF THE SOUTHWEST 1/4 OF SAID SECTION 29; THENCE S00°10'30"E, 783.52 FEET (D) (S00°10'21"E, 783.49 FEET FIELD), ALONG SAID EAST LINE OF THE SOUTHWEST 1/4, TO THE POINT OF BEGINNING, LESS RIGHT OF WAY FOR OVERPASS ROAD AND ALSO LESS THAT PORTION TAKEN BY THE STATE ROAD DEPARTMENT OF THE STATE OF FLORIDA, AN AGENCY OF THE STATE OF FLORIDA, AS SET FORTH ON THAT CERTAIN FINAL JUDGEMENT DATED APRIL 4, 1963 AND RECORDED IN CIRCUIT COURT MINUTE BOOK D, PAGE 271, PUBLIC RECORDS, PASCO COUNTY, FLORIDA, BEING DESCRIBED AS THE NORTH 80.0 FEET OF THE SOUTH 100.0 FEET OF THE EAST 548.64 FEET OF SAID SOUTHWEST 1/4 AND ALSO LESS RIGHT OF WAY FOR OLD PASCO ROAD, BEING FURTHER DESCRIBED AS FOLLOWS: COMMENCE AT THE SOUTHEAST CORNER OF THE SOUTHWEST 1/4 OF SECTION 29, TOWNSHIP 25 SOUTH, RANGE 20 EAST, PASCO COUNTY, FLORIDA, THENCE N00°10'21"W ALONG THE EAST LINE OF THE SOUTHWEST 1/4 OF SAID SECTION 29, 100.00 FEET TO A POINT ON THE NORTHERLY RIGHT OF WAY LINE OF OVERPASS ROAD AND THE POINT OF BEGINNING; THENCE ALONG THE NORTHERLY RIGHT OF WAY LINE OF OVERPASS ROAD AND THE EASTERLY RIGHT OF WAY LINE OF OLD

PASCO ROAD THE NEXT (7) SEVEN COURSES; (1) WEST 548.64 FEET; (2) S00°10'21"E, 80.00 FEET; (3) WEST, 1160.85 FEET; (4) N24°27'22"W, 20.06 FEET; (5) N10°04'17"E, 167.23 FEET; (6) N09°56'46"E, 777.66 FEET; (7) N09°35'29"E, 188.43 FEET; THENCE LEAVING SAID RIGHT OF WAY LINE S81°30'00"E, 744.04 FEET; THENCE N74°24'00"E, 372.50 FEET; THENCE S49°41'00"E, 558.55 FEET TO A POINT ON THE EAST BOUNDARY OF THE SOUTHWEST 1/4 OF SECTION 29; THENCE S00°10'21"E, ALONG SAID EAST BOUNDARY, 683.49 FEET TO THE POINT OF BEGINNING. AND LESS AND EXCEPT THAT PORTION DESCRIBED IN STIPULATED ORDER OF TAKING AND FINAL JUDGMENT RECORDED SEPTEMBER 15, 2020, IN BOOK 10176, PAGE 3291, PUBLIC RECORDS OF PASCO COUNTY, FLORIDA. AND ALSO LESS AND EXCEPT THAT PORTION CONVEYED TO PASCO COUNTY, A POLITICAL SUBDIVISION OF THE STATE OF FLORIDA IN SPECIAL WARRANT DEED RECORDED JANUARY 05, 2022 IN BOOK 10516, PAGE 2622, PUBLIC RECORDS OF PASCO COUNTY, FLORIDA.

## PARCEL 2:

A PARCEL OF LAND BEING A PORTION OF THAT CERTAIN PROPERTY AS DESCRIBED IN OFFICIAL RECORDS BOOK 9756, PAGE 226, OF THE PUBLIC RECORDS OF PASCO COUNTY, FLORIDA, LYING IN SECTION 29, TOWNSHIP 25 SOUTH, RANGE 20 EAST, PASCO COUNTY, FLORIDA, BEING MORE PARTICULARLY DESCRIBED AS FOLLOWS: BEGIN AT THE SOUTHEAST CORNER ACCORDING TO SAID PLAT OF PARK MEADOWS PHASE 2; THENCE LEAVING SAID EASTERLY RIGHT-OF-WAY LINE OF ADDITIONAL RIGHT-OF-WAY OF OLD PASCO ROAD, PARCEL 159.2, SAME BEING SAID WEST LINE OF THAT CERTAIN PROPERTY AS DESCRIBED IN OFFICIAL RECORDS BOOK 9756, PAGE 226, WITH A RADIAL BEARING OF N81°42'08"W, HAVING A RADIUS OF 2,368.50 FEET, A CENTRAL ANGLE OF 04°30'50", AN ARC LENGTH OF 186.59 FEET, AND A CHORD BEARING N06°02'27"E, FOR 186.54 FEET, TO THE POINT OF INTERSECTION WITH A NON-TANGENT LINE, SAME BEING THE SOUTH LINE OF SAID NORTH 1/2 OF SECTION 29, SAME ALSO BEING THE SOUTHWEST CORNER ACCORDING TO SAID PLAT OF PARK MEADOWS PHASE 2; THENCE LEAVING SAID EASTERLY RIGHT-OF-WAY LINE OF ADDITIONAL RIGHT-OF-WAY OF OLD PASCO ROAD, PARCEL 159.2, SAME BEING SAID WEST LINE OF THAT CERTAIN PROPERTY AS DESCRIBED IN OFFICIAL RECORDS BOOK 9756, PAGE 226, N89°55'34"E, ALONG SAID SOUTH LINE OF THE NORTH 1/2 OF THE SOUTHWEST 1/4 OF SECTION 29, SAME BEING THE SOUTH LINE OF SAID PLAT OF PARK MEADOWS PHASE 2 (BEING THE BASIS OF BEARINGS FOR THIS LEGAL DESCRIPTION), FOR 1,385.55 FEET TO THE POINT OF BEGINNING (collectively, the "Property").

SECTION 29, N49°45'28"W, FOR 558.73 FEET; (2) THENCE S74°19'32"W, FOR 372.50 FEET; (3) THENCE N81°34'28"W, FOR 629.10 FEET TO THE POINT OF INTERSECTION WITH A NON-TANGENT CURVE, CONCAVE WESTERLY, SAME BEING THE SOUTHEAST CORNER OF ADDITIONAL RIGHT-OF-WAY OF OLD PASCO ROAD, PARCEL 159.2, AS DESCRIBED IN OFFICIAL RECORDS BOOK 6267, PAGE 602, OF THE PUBLIC RECORDS OF PASCO COUNTY, FLORIDA, SAME ALSO BEING THE SOUTHWEST CORNER OF SAID CERTAIN PROPERTY AS DESCRIBED IN OFFICIAL RECORDS BOOK 9756, PAGE 226; THENCE NORTHERLY ALONG THE ARC OF SAID CURVE, SAME BEING THE EASTERLY RIGHT-OF-WAY LINE OF ADDITIONAL RIGHT-OF-WAY OF OLD PASCO ROAD, PARCEL 159.2, SAME ALSO BEING THE WEST LINE OF SAID CERTAIN PROPERTY AS DESCRIBED IN OFFICIAL RECORDS BOOK 9756, PAGE 226, WITH A RADIAL BEARING OF N81°42'08"W, HAVING A RADIUS OF 2,368.50 FEET, A CENTRAL ANGLE OF 04°30'50", AN ARC LENGTH OF 186.59 FEET, AND A CHORD BEARING N06°02'27"E, FOR 186.54 FEET, TO THE POINT OF INTERSECTION WITH A NON-TANGENT LINE, SAME BEING THE SOUTH LINE OF SAID NORTH 1/2 OF SECTION 29, SAME ALSO BEING THE SOUTHWEST CORNER ACCORDING TO SAID PLAT OF PARK MEADOWS PHASE 2; THENCE LEAVING SAID EASTERLY RIGHT-OF-WAY LINE OF ADDITIONAL RIGHT-OF-WAY OF OLD PASCO ROAD, PARCEL 159.2, SAME BEING SAID WEST LINE OF THAT CERTAIN PROPERTY AS DESCRIBED IN OFFICIAL RECORDS BOOK 9756, PAGE 226, N89°55'34"E, ALONG SAID SOUTH LINE OF THE NORTH 1/2 OF THE SOUTHWEST 1/4 OF SECTION 29, SAME BEING THE SOUTH LINE OF SAID PLAT OF PARK MEADOWS PHASE 2 (BEING THE BASIS OF BEARINGS FOR THIS LEGAL DESCRIPTION), FOR 1,385.55 FEET TO THE POINT OF BEGINNING (collectively, the "Property").

If you are a person with a disability who needs any accommodation in order to participate in this proceeding, you are entitled, at no cost to you, to the provision of certain assistance. Please contact the Office of the Court Administrator, 7530 Little Road, Port Richey, FL 34654, (727) 847-8135, at least seven days before your scheduled court appearance, or immediately upon receiving this notification if the time before the scheduled appearance is less than seven days; if you are hearing or voice impaired, call 711.

DATED THIS June 8, 2026.

Nikki Alvarez-Sowles, Esquire,  
Clerk & Comptroller  
Clerk of the Circuit Court  
of Pasco County  
By: Haley Joyner (Seal)  
As: Deputy Clerk  
June 12, 19, 26; July 3, 2026

26-01344P

## SECOND INSERTION

**NOTICE OF FORECLOSURE SALE IN THE CIRCUIT COURT OF THE SIXTH JUDICIAL CIRCUIT IN AND FOR PASCO COUNTY, FLORIDA**

CASE NO.: 2024-CA-002049 LAKEVIEW LOAN SERVICING, LLC, Plaintiff, vs.

ANDRE D. ROCKER, SR., et al., Defendants.

NOTICE is hereby given that Nikki Alvarez-Sowles, Esq., Clerk of the Circuit Court of Pasco County, Florida, will on July 23, 2026, at 11:00 a.m. ET, via the online auction site at www.pasco.realforeclose.com in accordance with Chapter 45, F.S., offer for sale and sell to the highest and best bidder for cash, the following described property situated in Pasco County, Florida, to wit:

Lot 18, CASSON HEIGHTS, according to the map or plat thereof as recorded in Plat Book 4, Page 95, Public Records of Pasco County, Florida.

Property Address: 6044 Sheelin Drive, New Port Richey, FL 34653 pursuant to the Final Judgment of Foreclosure entered in a case pending in said Court, the style and case number of which is set forth above.

Any person claiming an interest in the surplus from the sale, if any, other than the property owner as of the date of the Lis Pendens must file a claim before the clerk reports the surplus as

unclaimed.

If the sale is set aside for any reason, the Purchaser at the sale shall be entitled only to a return of the deposit paid. The Purchaser shall have no further recourse against the Mortgagor, the Mortgagee or the Mortgagee's attorney.

If you are a person with a disability who needs any accommodation in order to participate in this proceeding, you are entitled, at no cost to you, to the provision of certain assistance. Please contact either the Pasco County Customer Service Center, 8731 Citizens Drive, New Port Richey, FL 34654, (727) 847-2411 (V) of the Pasco County Risk Management Office, 7536 State Street, New Port Richey, FL 34654, (727) 847-8028 (V) at least 7 days before your scheduled court appearance, or immediately upon receiving this notification if the time before the scheduled appearance is less than 7 days; if you are hearing or voice impaired, call 711.

Dated this 12th day of June, 2026.  
TIFFANY & BOSCO, P.A.  
/s/ Kathryn I. Kasper, Esq.  
Anthony R. Smith, Esq.  
FL Bar #157147  
Kathryn I. Kasper, Esq.  
FL Bar #621188  
Attorneys for Plaintiff  
1201 S. Orlando Ave, Suite 430  
Winter Park, FL 32789  
Telephone: (205) 930-5200  
Facsimile: (407) 712-9201  
June 19, 26, 2026 26-01390P

## SECOND INSERTION

**NOTICE OF FORECLOSURE SALE IN THE CIRCUIT COURT OF THE SIXTH JUDICIAL CIRCUIT IN AND FOR PASCO COUNTY, FLORIDA**

CASE NO.: 2025-CA-000302 METROPOLITAN LIFE INSURANCE COMPANY, Plaintiff, vs.

UNKNOWN PERSONAL REPRESENTATIVE OF THE ESTATE OF ISIDRO A. BERNABE A/K/A ISIDRO BERNABE, et al., Defendants.

NOTICE is hereby given that, Nikki Alvarez-Sowles, Esq., Clerk of the Circuit Court of Pasco County, Florida, will on July 14, 2026, at 11:00 a.m. ET, via the online auction site at www.pasco.realforeclose.com in accordance with Chapter 45, F.S., offer for sale and sell to the highest and best bidder for cash, the following described property situated in Pasco County, Florida, to wit:

Lot 1, Block AB, GROVES-PHASE IA, according to the map or plat thereof as recorded in Plat Book 39, Page 120-150, of the Public Records of Pasco County, Florida.  
Property Address: 7451 Trovita Road, Land O Lakes, FL 34637 pursuant to the Final Judgment of Foreclosure entered in a case pending in said Court, the style and case number of which is set forth above.  
Any person claiming an interest in the surplus from the sale, if any, other than the property owner as of the date of the Lis Pendens must file a claim

before the clerk reports the surplus as unclaimed.

If the sale is set aside for any reason, the Purchaser at the sale shall be entitled only to a return of the deposit paid. The Purchaser shall have no further recourse against the Mortgagor, the Mortgagee or the Mortgagee's attorney.

If you are a person with a disability who needs any accommodation in order to participate in this proceeding, you are entitled, at no cost to you, to the provision of certain assistance. Please contact either the Pasco County Customer Service Center, 8731 Citizens Drive, New Port Richey, FL 34654, (727) 847-2411 (V) of the Pasco County Risk Management Office, 7536 State Street, New Port Richey, FL 34654, (727) 847-8028 (V) at least 7 days before your scheduled court appearance, or immediately upon receiving this notification if the time before the scheduled appearance is less than 7 days; if you are hearing or voice impaired, call 711.

Dated this 15th day of June, 2026.  
TIFFANY & BOSCO, P.A.  
/s/ Kathryn I. Kasper, Esq.  
Anthony R. Smith, Esq.  
FL Bar #157147  
Kathryn I. Kasper, Esq.  
FL Bar #621188  
Attorneys for Plaintiff  
1201 S. Orlando Ave, Suite 430  
Winter Park, FL 32789  
Telephone: (205) 930-5200  
Facsimile: (407) 712-9201  
June 19, 26, 2026 26-01405P

## SECOND INSERTION

**NOTICE OF FORECLOSURE SALE IN THE CIRCUIT COURT OF THE SIXTH JUDICIAL CIRCUIT IN AND FOR PASCO COUNTY, FLORIDA CIVIL DIVISION**

CASE NO. 2025CA001252CAAXES DIVISION: JI

WILMINGTON SAVINGS FUND SOCIETY, FSB, NOT IN ITS INDIVIDUAL CAPACITY, BUT SOLELY AS OWNER TRUSTEE OF CSMC 2019-RPL5 TRUST, Plaintiff, vs.

JULIET FLORES VALDES A/K/A JULIET FLORES-VALDES F/K/A JULIET GARCIA-VALDES; UNKNOWN SPOUSE OF JULIET FLORES-VALDES F/K/A JULIET GARCIA-VALDES N/K/A JUAN FLORES; MARIA SILVA VALDES A/K/A MARIA S. VALDES A/K/A MARIA VALDES; LUIS ANGEL LEIVA A/K/A LUIS A. LEIVA A/K/A LUIS A. LEYVA; ASBEL CREEK ASSOCIATION, INC.; TBF FINANCIAL, LLC; UNKNOWN TENANT #1; UNKNOWN TENANT #2; ALL OTHER UNKNOWN PARTIES CLAIMING INTERESTS BY, THROUGH, UNDER, AND AGAINST THE HEREIN NAMED DEFENDANT(S) WHO ARE NOT KNOWN TO BE DEAD OR ALIVE, WHETHER SAME UNKNOWN PARTIES MAY CLAIM AN INTEREST AS SPOUSES, HEIRS, DEVISEES, GRANTEES, OR OTHER CLAIMANTS

## Defendant(s).

NOTICE IS HEREBY GIVEN that pursuant to an Order Resetting Foreclosure Sale entered on May 22, 2026 in the Circuit Court of the Sixth Judicial Circuit and for Pasco County, Florida, Nikki Alvarez-Sowles, Esq., the Clerk of Court will on JULY 15, 2026 at 11:00 a.m., offer for sale and sell at public outcry to the highest and best bidder for cash at www.pasco.realforeclose.com the following described property situated in Pasco County, Florida:

LOT 36, BLOCK E, ASBEL CREEK PHASE FOUR, ACCORDING TO THE MAP OR PLAT THEREOF AS RECORDED IN PLAT BOOK 57, PAGES 136-143, OF THE PUBLIC RECORDS OF PASCO COUNTY, FLORIDA.

Property Address: 9831 Edmonton Drive, Land O Lakes, FL 34638  
Any person claiming an interest in the surplus from the sale, if any, other than the property owner as of the date of the Lis Pendens must file a claim before the clerk reports the surplus as unclaimed.

Dated: June 9, 2026  
/s/ Gina Vargas  
Gina Vargas, Esq.  
Florida Bar No. 84149  
MCMICHAEL TAYLOR GRAY, LLC  
3550 Engineering Drive, Suite 260  
Peachtree Corners, GA 30092  
Phone: (954) 640-0294 x 3163  
Email: gvargas@mtglaw.com  
E-Service: servicef@mtglaw.com  
June 19, 26, 2026 26-01372P

--- ACTIONS / SALES ---

SECOND INSERTION

**NOTICE OF ACTION**  
IN THE CIRCUIT COURT OF THE SIXTH JUDICIAL CIRCUIT OF FLORIDA IN AND FOR PASCO COUNTY  
**GENERAL JURISDICTION DIVISION**  
**CASE NO. 2026CA001201CAAXES**  
**FREEDOM MORTGAGE CORPORATION,**  
**Plaintiff, vs.**  
**KARTHIK REDDY ALLU, et al.,**  
**Defendant.**  
To: KARTHIK REDDY ALLU, 35724 DOVELAND DRIVE, ZEPHYRHILLS, FL 33541  
KEERTHI GADDA, 35724 DOVELAND DRIVE, ZEPHYRHILLS FL 33541  
LAST KNOWN ADDRESS STATED, CURRENT RESIDENCE UNKNOWN  
YOU ARE HEREBY NOTIFIED that an action for Foreclosure of Mortgage on the following described property:  
LOT 36, ZEPHYR RIDGE PHASE 2, ACCORDING TO THE PLAT AS RECORDED IN PLAT BOOK 89, PAGES 63 THROUGH 66, OF THE PUBLIC RECORDS OF PASCO COUNTY, FLORIDA.  
has been filed against you and you are required to file a copy of your written defenses, if any, to it on Curtis Wilson, Esq., McCalla Raymer Leibert Pierce, LLP, 225 East Robinson Street, Suite 155, Orlando, FL 32801 and file the original with the Clerk of the above-styled Court on or before JULY 20, 2026 or 30 days from the first publication, otherwise a Judgment may be

entered against you for the relief demanded in the Complaint.  
If you are a person with a disability who needs any accommodation in order to participate in this proceeding, you are entitled, at no cost to you, to the provision of certain assistance. Please contact the Public Information Dept., Pasco County Government Center, 7530 Little Rd., New Port Richey, FL 34654; (727) 847-8110 (V) in New Port Richey; (352) 521-4274, ext 8110 (V) in Dade City, at least 7 days before your scheduled court appearance, or immediately upon receiving this notification if the time before the scheduled appearance is less than 7 days; if you are hearing impaired call 711. The court does not provide transportation and cannot accommodate for this service. Persons with disabilities needing transportation to court should contact their local public transportation providers for information regarding transportation services.  
WITNESS my hand and seal of this Court on the 16th day of June, 2026.  
NIKKI ALVAREZ-SOWLES, ESQ.,  
CLERK OF COURT OF PASCO COUNTY  
As Clerk of the Court  
(SEAL) BY: Shakira Ramirez Pagan  
Deputy Clerk  
MCCALLA RAYMER LEIBERT PIERCE, LLP  
225 East Robinson Street, Suite 155, Orlando, FL 32801  
Phone: (407) 674-1850  
Fax: (321) 248-0420  
Email:AccountsPayables@mccalla.com  
June 19, 26, 2026 26-01419P

SECOND INSERTION

**NOTICE OF SALE**  
IN THE CIRCUIT CIVIL COURT OF THE SIXTH JUDICIAL CIRCUIT OF FLORIDA, IN AND FOR PASCO COUNTY  
**CIVIL DIVISION**  
**Case No. 2025CA003275CAAXWS**  
**NEWREZ LLC D/B/A SHELLPOINT MORTGAGE SERVICING**  
**Plaintiff, vs.**  
**SHENG CHUN GUO, WAN XIA LIN, STARKEY RANCH MASTER PROPERTY OWNER'S ASSOCIATION, INC., UNKNOWN SPOUSE OF SHENG CHUN GUO, UNKNOWN SPOUSE OF WAN XIA LIN, AND UNKNOWN TENANTS/ OWNERS,**  
**Defendants.**  
Notice is hereby given, pursuant to Final Judgment of Foreclosure for Plaintiff entered in this cause on June 8, 2026, in the Circuit Court of Pasco County, Florida, Nikki Alvarez-Sowles, Esq., Clerk of the Circuit Court, will sell the property situated in Pasco County, Florida described as:  
LOT 11, BLOCK 8 OF STARKEY RANCH PARCEL D PHASE 1, ACCORDING TO THE PLAT THEREOF, AS RECORDED IN PLAT BOOK 76, PAGES 1-7, OF THE PUBLIC RECORDS OF PASCO COUNTY, FLORIDA.  
and commonly known as: 3904 VILLAMORE LN, ODESSA, FL 33556; including the building, appurtenances, and fixtures located therein, at public sale, to the highest and best bidder, for cash, online at www.pasco.realforeclose.com, on August 10, 2026 at 11:00 A.M..  
Any persons claiming an interest in the surplus from the sale, if any, other than the property owner as of the date of the lis pendens must file a claim before the clerk reports the surplus as unclaimed.  
If you are a person with a disability who needs any accommodation in order to participate in this proceeding, you are entitled, at no cost to you, to the provision of certain assistance. Please contact the Public Information Dept., Pasco County Government Center, 7530 Little Rd., New Port Richey, FL 34654; (727) 847-8110 (V) in New Port Richey; (352) 521-4274, ext 8110 (V) in Dade City, at least 7 days before your scheduled court appearance, or immediately upon receiving this notification if the time before the scheduled appearance is less than 7 days; if you are hearing impaired call 711. The court does not provide transportation and cannot accommodate for this service. Persons with disabilities needing transportation to court should contact their local public transportation providers for information regarding transportation services.  
Dated: June 15, 2026  
By: /s/ David R. Byars  
David R. Byars  
Attorney for Plaintiff  
Invoice to:  
Kass Shuler, P.A.  
1604 N. Marion St.  
Tampa, FL 33602  
ForeclosureService@kasslaw.com  
328202/2531751/wll  
June 19, 26, 2026 26-01404P

**NOTICE OF SALE UNDER E.S. CHAPTER 45**  
**Bidder Number: 17388**  
IN THE CIRCUIT COURT OF THE SIXTH JUDICIAL CIRCUIT, IN AND FOR PASCO COUNTY, FLORIDA  
**Case No. 2025-CA-003846**  
**Honorable Judge: LEWIS, KEMBA DAMALI JOHNSON**  
**PLANET HOME LENDING, LLC**  
**Plaintiff, vs.**  
**MELISSA KENYON; UNKNOWN SPOUSE OF MELISSA KENYON; THRIVE MORTGAGE, LLC; UNKNOWN TENANT OCCUPANT #1; UNKNOWN TENANT OCCUPANT #2;**  
**Defendants,**  
NOTICE IS GIVEN that, in accordance with the Final Judgment of Foreclosure dated June 4, 2026, in the above-styled cause, Nikki Alvarez-Sowles, ESQ., as the Clerk of the Circuit Court, will sell to the highest and best bidder for cash online at: www.pasco.realforeclose.com at 11:00 AM on August 18, 2026, the following described property:  
LOT 46, BROWN ACRES UNIT TWO, ACCORDING TO THE MAP OR PLAT THEREOF, AS RECORDED IN PLAT BOOK 7, PAGE 139, OF THE PUBLIC RECORDS OF PASCO COUNTY, FLORIDA.  
APN No.  
09-25-16-0030-00000-0460  
COMMONLY KNOWN AS:  
6702 Sandra Dr, Port Richey, FL 34668  
ANY PERSON CLAIMING AN INTEREST IN THE SURPLUS FROM THE SALE, IF ANY, OTHER THAN

SECOND INSERTION

THE PROPERTY OWNER AS OF THE DATE OF THE LIS PENDENS MUST FILE A CLAIM BEFORE THE CLERK REPORTS THE SURPLUS AS UNCLAIMED.  
ADA INFORMATION:  
If you are a person with a disability who needs any accommodation in order to participate in this proceeding, you are entitled, at no cost to you, to the provision of certain assistance. Please contact either the Pasco County Customer Service Center, 8731 Citizens Drive, New Port Richey, FL 34654, (727) 847-2411 (V) or the Pasco County Risk Management Office, 7536 State Street, New Port Richey, FL 34654, (727) 847-8028 (V) at least 7 days before your scheduled court appearance, or immediately upon receiving this notification if the time before the scheduled appearance is less than 7 days; if you are hearing or voice impaired, call 711.  
Contact should be initiated at least seven days before the scheduled court appearance, or immediately upon receiving this notification if the time before the scheduled appearance is less than seven days.  
Dated this June 12, 2026.  
/s/ Matthew T. Wasinger  
Matthew T. Wasinger, Esquire  
Wasinger Law Office  
605 E. Robinson, Suite 730  
Orlando, FL 32801  
(407) 308-0991  
Fla. Bar No.: 0057873  
Attorney for Plaintiff  
Service:  
mattw@wasingerlawoffice.com  
June 19, 26, 2026 26-01391P

hearing impaired. Contact should be initiated at least seven days before the scheduled court appearance, or immediately upon receiving this notification if the time before the scheduled appearance is less than seven days. The court does not provide transportation and cannot accommodate such requests. Persons with disabilities needing transportation to court should contact their local public transportation providers for information regarding transportation services.  
Dated this 12th day of June, 2026.  
ALDRIDGE PITE, LLP  
Attorney for Plaintiff  
401 W. Linton Blvd., Suite 202-B  
Delray Beach, FL 33444  
Telephone: 561-392-6391  
Facsimile: 561-392-6965  
By: /s/ Zachary Ullman  
Zachary Ullman, Esq.  
FBN: 106751  
Primary E-Mail:  
ServiceMail@aldridgepite.com  
1719-004B  
June 19, 26, 2026 26-01403P

SECOND INSERTION

**NOTICE OF ACTION; CONSTRUCTIVE SERVICE - PROPERTY**  
IN THE CIRCUIT COURT OF THE SIXTH JUDICIAL CIRCUIT OF THE STATE OF FLORIDA, IN AND FOR PASCO COUNTY, CIVIL DIVISION  
**CASE NO.: 2026CA001206**  
**TH MSR HOLDINGS LLC,**  
**Plaintiff, vs.**  
**SAMUEL SIEBU; et al.,**  
**Defendants.**  
TO: ZINNA HILL TRUST; 6900 TAVISTOCK BLVD, SUITE 400, ORLANDO, FL 32827  
YOU ARE NOTIFIED that an action to foreclose to the following property in Pasco County, Florida:  
LOT 25, BLOCK 62, SEVEN OAKS PARCEL C-1C/C-1D, ACCORDING TO THE MAP OR PLAT THEREOF, AS RECORDED IN PLAT BOOK 57, PAGE(S) 42 THROUGH 54 INCLUSIVE, OF THE PUBLIC RECORDS OF PASCO COUNTY, FLORIDA.  
Also known as 4238 WILDSTAR CIR, WESLEY CHAPEL, FL 33544.  
has been filed against you and you are required to serve a copy of your written defenses, if any, to it on Sokolof Remtulla, LLP, the plaintiff's attorney, whose address is 1800 NW Corporate Blvd Suite 302 Boca Raton FL 33431, on or before JULY 20, 2026, and file the original with the clerk of this court either before service on the plaintiff's attorney or immediately thereafter; otherwise a default will be entered against you for

the relief demanded in the complaint or petition.  
**IMPORTANT AMERICANS WITH DISABILITIES ACT:** If you are a person with a disability who needs an accommodation in order to participate in this proceeding, you are entitled, at no cost to you, to the provision of certain assistance. Please contact: Public Information Dept., Pasco County Government Center, 7530 Little Rd., New Port Richey, FL 34654; Phone: 727.847.2411 (voice) in New Port Richey, 727.847.8028 (voice) in Dade City, Or 711 for the hearing impaired. Contact should be initiated at least seven days before the scheduled court appearance, or immediately upon receiving this notification if the time before the scheduled appearance is less than seven days. The court does not provide transportation and cannot accommodate such requests. Persons with disabilities needing transportation to court should contact their local public transportation providers for information regarding transportation services.  
DATED on June 17, 2026.  
NIKKI ALVAREZ-SOWLES, ESQ.,  
CLERK OF THE CIRCUIT COURT  
By: Shakira Ramirez Pagan  
DEPUTY CLERK  
SOKOLOF REMTULLA, LLP  
1800 NW Corporate Blvd  
Suite 302  
Boca Raton FL 33431  
Telephone: 561-507-5252  
Facsimile: 561-342-4842  
E-mail: pleadings@sokrem.com  
Counsel for Plaintiff  
June 19, 26, 2026 26-01417P

**NOTICE OF FORECLOSURE SALE PURSUANT TO CHAPTER 45**  
IN THE CIRCUIT COURT OF THE SIXTH JUDICIAL CIRCUIT IN AND FOR PASCO COUNTY, FLORIDA  
**CASE NO.: 2025CA002673**  
**CARRINGTON MORTGAGE SERVICES, LLC,**  
**Plaintiff, vs.**  
**DYLAN L. REVELS A/K/A DYLAN LAVAN REVELS A/K/A DYLAN REVELS; MIRANDA REVELS; MORTGAGE ELECTRONIC REGISTRATION SYSTEMS INC., ACTING SOLELY AS A NOMINEE FOR GERSHAM INVESTMENT CORP.; SANDALWOOD MOBILE HOME COMMUNITY HOMEOWNERS ASSOCIATION, INC.; UNKNOWN TENANT #1; UNKNOWN TENANT #2;**  
**Defendant(s).**  
NOTICE IS HEREBY GIVEN that sale will be made pursuant to an Order or Final Judgment. Final Judgment was awarded on June 9, 2026 in Civil Case No. 2025CA002673, of the Circuit

Court of the SIXTH Judicial Circuit in and for Pasco County, Florida, wherein, CARRINGTON MORTGAGE SERVICES, LLC is the Plaintiff, and DYLAN L. REVELS A/K/A DYLAN LAVAN REVELS A/K/A DYLAN REVELS; MIRANDA REVELS; MORTGAGE ELECTRONIC REGISTRATION SYSTEMS INC., ACTING SOLELY AS A NOMINEE FOR GERSHAM INVESTMENT CORP.; SANDALWOOD MOBILE HOME COMMUNITY HOMEOWNERS ASSOCIATION, INC. are Defendants.  
The Clerk of the Court, Nikki Alvarez-Sowles, Esq. will sell to the highest bidder for cash at www.pasco.realforeclose.com on August 10, 2026 at 11:00:00 AM EST the following described real property as set forth in said Final Judgment, to wit:  
LOT 176, SANDALWOOD MOBILE HOME COMMUNITY, ACCORDING TO THE PLAT THEREOF AS RECORDED IN PLAT BOOK 23, PAGE 149, PUBLIC RECORDS OF PASCO

SECOND INSERTION

COUNTY, FLORIDA  
TOGETHER WITH THAT CERTAIN RETIRED 1986 HOME OF MERIT DOUBLEWIDE MOBILE HOME, VIN #S FLHMB04420188A AND FLHMB04420188B AND TITLE #S 140029251 AND 140029302  
Any person claiming an interest in the surplus from the sale, if any, other than the property owner as of the date of the lis pendens must file a claim before the clerk reports the surplus as unclaimed.  
**IMPORTANT AMERICANS WITH DISABILITIES ACT:** If you are a person with a disability who needs an accommodation in order to participate in this proceeding, you are entitled, at no cost to you, to the provision of certain assistance. Please contact: Public Information Dept., Pasco County Government Center, 7530 Little Rd., New Port Richey, FL 34654; Phone: 727.847.8110 (voice) in New Port Richey, 352.521.4274, ext 8110 (voice) in Dade City, Or 711 for the

NO. 583; THENCE NORTH 24 DEGREES, 07 MINUTES, 00 SECONDS EAST, ALONG STATED BOUNDARY OF S.R. NO. 583, A DISTANCE OF 1935.97 FEET; THENCE SOUTH 65 DEGREES, 53 MINUTES, 00 SECONDS EAST, A DISTANCE OF 223.99 FEET TO A POINT OF CURVATURE; THENCE ON A CURVE TO THE LEFT, ON AN ARC OF 279.76 FEET, WITH A RADIUS OF 478.00 FEET SUBTENDED BY A CHORD OF 275.78 FEET, CHORD BEARING SOUTH 82 DEGREES, 39 MINUTES, 00 SECONDS EAST TO A POINT OF REVERSE CURVATURE; THENCE ON A CURVE TO THE RIGHT, ON AN ARC OF 283.70 FEET, WITH A RADIUS OF 622.00 FEET, SUBTENDED BY A CHORD OF 281.25 FEET, CHORD BEARING SOUTH 86, DEGREES, 21 MINUTES, 00 SECONDS EAST TO A POINT OF REVERSE CURVATURE; THENCE ON A CURVE TO THE LEFT ON AN ARC OF 521.57 FEET, WITH A RADIUS OF 964.00 FEET, SUBTENDED BY A CHORD OF 515.24 FEET, CHORD BEARING SOUTH 86, DEGREES, 21 MINUTES, 00 SECONDS EAST TO A POINT OF REVERSE CURVATURE; THENCE NORTH 75 DEGREES, 43 MINUTES, 00 SECONDS EAST, A DISTANCE OF 247.00 FEET FOR A POINT OF BEGINNING; THENCE NORTH 14 DEGREES, 17 MINUTES, 00 SECONDS WEST, A DISTANCE

SECOND INSERTION

**NOTICE OF SALE**  
IN THE CIRCUIT CIVIL COURT OF THE SIXTH JUDICIAL CIRCUIT OF FLORIDA, IN AND FOR PASCO COUNTY  
**CIVIL DIVISION**  
**Case No. 2025-CA-000480**  
**NEWREZ LLC D/B/A SHELLPOINT MORTGAGE SERVICING**  
**Plaintiff, vs.**  
**GEORGE I. MANLEY, III, UNKNOWN SPOUSE OF GEORGE I. MANLEY, III, AND UNKNOWN TENANTS/OWNERS,**  
**Defendants.**  
Notice is hereby given, pursuant to Final Judgment of Foreclosure for Plaintiff entered in this cause on June 5, 2026, in the Circuit Court of Pasco County, Florida, Nikki Alvarez-Sowles, Esq., Clerk of the Circuit Court, will sell the property situated in Pasco County, Florida described as:  
TRACT B:  
A PORTION OF LOT 49, BAHIA ACRES, UNRECORDED, BEING FURTHER DESCRIBED AS FOLLOWS: A PARCEL OF LAND LYING IN SECTION 20, TOWNSHIP 25 SOUTH, RANGE 19 EAST, PASCO COUNTY, FLORIDA; MORE PARTICULARLY DESCRIBED AS FOLLOWS: COMMENCE AT THE SOUTH-WEST CORNER OF SAID SECTION 20; THENCE NORTH 89 DEGREES, 00 MINUTES, 00 SECONDS EAST, A DISTANCE OF 558.35 FEET TO A POINT ON THE EASTERLY RIGHT-OF-WAY BOUNDARY OF S.R.

OF 30.00 FEET; THENCE NORTH 12 DEGREES, 48 MINUTES, 15 SECONDS WEST A DISTANCE OF 287.25 FEET, THENCE SOUTH 86 DEGREES, 20 MINUTES, 05 SECONDS EAST A DISTANCE OF 200.00 FEET; THENCE SOUTH 02 DEGREES, 38 MINUTES, 21 SECONDS EAST, A DISTANCE OF 236.28 FEET; THENCE SOUTH 07 DEGREES, 51 MINUTES, 24 SECONDS EAST A DISTANCE OF 30.00 FEET TO A POINT ON A CURVE; THENCE ON A CURVE TO THE LEFT, ON AN ARC OF 101.85 FEET WITH A RADIUS OF 908.00 FEET; SUBTENDED BY A CHORD OF 101.80 FEET, CHORD BEARING SOUTH 78 DEGREES, 55 MINUTES, 48 SECONDS WEST, THENCE SOUTH 75 DEGREES, 43 MINUTES, 00 SECONDS WEST A DISTANCE OF 45.00 FEET TO THE POINT OF BEGINNING; RESERVING TO THE GRANTORS, ITS HEIRS, SUCCESSORS AND ASSIGNS A PERPETUAL NONEXCLUSIVE EASEMENT FOR ROAD RIGHT-OF-WAY OVER AND UPON THE SOUTHERLY 30 FEET OF THE ABOVE DESCRIBED PROPERTY.  
and commonly known as: 9331 BAHIA LOOP, LAND O LAKES, FL 34639; including the building, appurtenances, and fixtures located therein, at public sale, to the highest and best bidder, for cash, online at www.pasco.

realforeclose.com, on September 8, 2026 11:00 A.M.  
Any persons claiming an interest in the surplus from the sale, if any, other than the property owner as of the date of the lis pendens must file a claim before the clerk reports the surplus as unclaimed.  
If you are a person with a disability who needs any accommodation in order to participate in this proceeding, you are entitled, at no cost to you, to the provision of certain assistance. Please contact the Public Information Dept., Pasco County Government Center, 7530 Little Rd., New Port Richey, FL 34654; (727) 847-8110 (V) in New Port Richey; (352) 521-4274, ext 8110 (V) in Dade City, at least 7 days before your scheduled court appearance, or immediately upon receiving this notification if the time before the scheduled appearance is less than 7 days; if you are hearing impaired call 711. The court does not provide transportation and cannot accommodate for this service. Persons with disabilities needing transportation to court should contact their local public transportation providers for information regarding transportation services.  
Dated: June 11, 2026  
By: /s/ David R. Byars  
David R. Byars  
Attorney for Plaintiff  
Invoice to:  
Kass Shuler, P.A.  
1604 N. Marion St.  
Tampa, FL 33602  
ForeclosureService@kasslaw.com  
F328202/2528620/wll  
June 19, 26, 2026 26-01373P

TOGETHER WITH THE MOBILE HOME SITUATED THERE ON WHICH IS AFFIXED TO THE FOREMENTIONED REAL PROPERTY AND INCORPORATED THEREIN.  
Property Address: 13115 Rose Terrace, Hudson, Florida 34669 and all fixtures and personal property located therein or thereon, which are included as security in Plaintiff's mortgage.  
Any person claiming an interest in the surplus funds from the sale, if any, other than the property owner as of the date of the lis pendens must file a claim before the clerk reports the surplus as unclaimed.  
If you are a person with a disability who needs any accommodation in order to participate in this proceeding, you are entitled, at no cost to you, to the provision of certain assistance. Please contact the Pasco County Human Resources Office, 8731 Citizens Drive, Suite 330, New Port Richey FL 34654, (727) 847-8103 (V) at least 7 days before your scheduled court appearance, or immediately upon receiving this notification if the time before the scheduled appearance is less than 7 days; if you are hearing or voice impaired, call 711.  
Dated: 6/17/2026  
McCabe, Weisberg & Conway, LLC  
By: /s/ Craig Stein  
Craig Stein, Esq.  
Fl Bar No. 0120464  
McCabe, Weisberg & Conway, LLC  
3222 Commerce Place, Suite A  
West Palm Beach, Florida, 33407  
Telephone: (561) 713-1400  
Email: FlPleadings@mwc-law.com  
File No: 24-400028  
June 19, 26, 2026 26-01431P

SECOND INSERTION

**NOTICE OF SALE**  
IN THE CIRCUIT COURT OF THE 6TH JUDICIAL CIRCUIT IN AND FOR PASCO COUNTY, FLORIDA  
**CASE NO.: 2025CA003904CAAXWS**  
**DEUTSCHE BANK NATIONAL TRUST COMPANY, AS TRUSTEE FOR AMERIQUEST MORTGAGE SECURITIES INC., ASSET-BACKED PASS-THROUGH CERTIFICATES, SERIES 2005-R1,**  
**Plaintiff, vs.**  
**WILLIAM MORAN A/K/A WILLIAM H. MORAN; JEANA MORAN A/K/A JEANA G. MORAN,**  
**Defendant(s).**  
NOTICE OF SALE IS HEREBY GIVEN pursuant to the order of Uniform Final Judgment of Foreclosure dated June 8, 2026, and entered in Case No. 2025CA003904CAAXWS of the Circuit Court of the 6TH Judicial Circuit in and for Pasco County, Florida, wherein Deutsche Bank National Trust Company, as Trustee for Ameriquest Mortgage Securities Inc., Asset-Backed Pass-Through Certificates, Series 2005-R1, is Plaintiff and William Moran a/k/a William H. Moran; Jeana Moran a/k/a Jeana G. Moran, are Defendants, the Office of the Clerk of Nikki Alvarez-Sowles, Esq., Pasco County Clerk of the Court will sell via online auction at www.pasco.realforeclose.com at 11:00 A.M. on the 30th day of July, 2026, the following described property as set forth in said Final Judgment, to wit:  
LOT 210 OF COLONY VILLAGE, UNIT ONE, AS PER PLAT THEREOF RECORDED IN PLAT BOOK 9, PAGES 137 AND 138 OF THE PUBLIC RECORDS OF PASCO COUNTY, FLORIDA.

TOGETHER WITH THE MOBILE HOME SITUATED THERE ON WHICH IS AFFIXED TO THE FOREMENTIONED REAL PROPERTY AND INCORPORATED THEREIN.  
Property Address: 13115 Rose Terrace, Hudson, Florida 34669 and all fixtures and personal property located therein or thereon, which are included as security in Plaintiff's mortgage.  
Any person claiming an interest in the surplus funds from the sale, if any, other than the property owner as of the date of the lis pendens must file a claim before the clerk reports the surplus as unclaimed.  
If you are a person with a disability who needs any accommodation in order to participate in this proceeding, you are entitled, at no cost to you, to the provision of certain assistance. Please contact the Pasco County Human Resources Office, 8731 Citizens Drive, Suite 330, New Port Richey FL 34654, (727) 847-8103 (V) at least 7 days before your scheduled court appearance, or immediately upon receiving this notification if the time before the scheduled appearance is less than 7 days; if you are hearing or voice impaired, call 711.  
Dated: 6/17/2026  
McCabe, Weisberg & Conway, LLC  
By: /s/ Craig Stein  
Craig Stein, Esq.  
Fl Bar No. 0120464  
McCabe, Weisberg & Conway, LLC  
3222 Commerce Place, Suite A  
West Palm Beach, Florida, 33407  
Telephone: (561) 713-1400  
Email: FlPleadings@mwc-law.com  
File No: 24-400028  
June 19, 26, 2026 26-01431P

**Who benefits from legal notices?**  
You do. Legal notices are required because a government body or corporation wants to take action that can affect individuals and the public at large.  
When the government is about to change your life, or your property or assets are about to be taken, public notices in newspapers serve to alert those affected.

MCCBEE VOS

--- ACTIONS / SALES ---

SECOND INSERTION

NOTICE OF ACTION - CONSTRUCTIVE SERVICE IN THE CIRCUIT COURT OF THE SIXTH JUDICIAL CIRCUIT IN AND FOR PASCO COUNTY, FLORIDA GENERAL JURISDICTION DIVISION CASE NO. 2026CA001611CAAXWS FINANCE OF AMERICA REVERSE LLC, Plaintiff, vs. THE UNKNOWN HEIRS, BENEFICIARIES, DEVISEES, GRANTEEES, ASSIGNEES, LIENORS, CREDITORS, TRUSTEES AND ALL OTHERS WHO MAY CLAIM AN INTEREST IN THE ESTATE OF GEORGE SAVVAS, DECEASED. et. al. Defendant(s), TO: THE UNKNOWN HEIRS, BENEFICIARIES, DEVISEES, GRANTEEES, ASSIGNEES, LIENORS, CREDITORS, TRUSTEES AND ALL OTHERS WHO MAY CLAIM AN INTEREST IN THE ESTATE OF

GEORGE SAVVAS, DECEASED, whose residence is unknown if he/she/they be living; and if he/she/they be dead, the unknown defendants who may be spouses, heirs, devisees, grantees, assignees, lienors, creditors, trustees, and all parties claiming an interest by, through, under or against the Defendants, who are not known to be dead or alive, and all parties having or claiming to have any right, title or interest in the property described in the mortgage being foreclosed herein. YOU ARE HEREBY NOTIFIED that an action to foreclose a mortgage on the following property: LOT 90, AND THE WEST 35.00 FEET OF LOT 89, HILL-ANDALE UNIT 2, ACCORDING TO THE PLAT THEREOF RECORDED AT PLAT BOOK 11, PAGE 108, IN THE PUBLIC RECORDS OF PASCO COUNTY, FLORIDA. has been filed against you and you are required to serve a copy of your writ-

ten defenses, if any, to it on counsel for Plaintiff, whose address is 6409 Congress Ave., Suite 100, Boca Raton, Florida 33487 on or before JULY 20TH, 2026/(30 days from Date of First Publication of this Notice) and file the original with the clerk of this court either before service on Plaintiff's attorney or immediately thereafter; otherwise a default will be entered against you for the relief demanded in the complaint or petition filed herein. If you are a person with a disability who needs any accommodation in order to participate in this proceeding, you are entitled, at no cost to you, to the provision of certain assistance. Please contact the Public Information Dept., Pasco County Government Center, 7530 Little Rd., New Port Richey, FL 34654; (727) 847-8110 (V) in New Port Richey; (352) 521-4274, ext 8110 (V) in Dade City, at least 7 days before your scheduled court appearance, or immediately upon receiving this notification if the time before the scheduled appear-

ance is less than 7 days; if you are hearing impaired call 711. The court does not provide transportation and cannot accommodate for this service. Persons with disabilities needing transportation to court should contact their local public transportation providers for information regarding transportation services. WITNESS my hand and the seal of this Court at Pasco County, Florida, this June 11, 2026 Nikki Alvarez-Sowles Pasco County Clerk & Comptroller (Seal) By: Haley Joyner Deputy Clerk ROBERTSON, ANSCHUTZ, AND SCHNEID, PL ATTORNEY FOR PLAINTIFF 6409 Congress Ave., Suite 100 Boca Raton, FL 33487 PRIMARY EMAIL: flmail@raslg.com 26-409007 June 19, 26, 2026 26-01374P

SECOND INSERTION

NOTICE OF FORECLOSURE SALE IN THE CIRCUIT COURT OF THE SIXTH JUDICIAL CIRCUIT IN AND FOR PASCO COUNTY, FLORIDA CASE NO.: 2025-CA-002535 LAKEVIEW LOAN SERVICING, LLC, Plaintiff, vs. DARRYL TURMEL, et al., Defendants. NOTICE IS HEREBY GIVEN that Nikki Alvarez-Sowles, Esq., Clerk of the Circuit Court of Pasco County, Florida, will on July 29, 2026, at 11:00 a.m. ET, via the online auction site at www.pasco.realforeclose.com in accordance with Chapter 45, F.S., offer for sale and sell to the highest and best bidder for cash, the following described property situated in Pasco County, Florida, to wit: Lots 10, 11 and 12, Block D, SUWANNEE PARK SUBDIVISION, according to the map or plat thereof as recorded in Plat Book 3, Page 18, Public Records of Pasco County, Florida. Property Address: 36733 Thomas Jefferson Road, Dade City, FL 33525 pursuant to the Final Judgment of Foreclosure entered in a case pending in said Court, the style and case number of which is set forth above. Any person claiming an interest in the surplus from the sale, if any, other than the property owner as of the date of the Lis Pendens must file a claim

before the clerk reports the surplus as unclaimed. If the sale is set aside for any reason, the Purchaser at the sale shall be entitled only to a return of the deposit paid. The Purchaser shall have no further recourse against the Mortgagee, the Mortgagee or the Mortgagee's attorney. If you are a person with a disability who needs any accommodation in order to participate in this proceeding, you are entitled, at no cost to you, to the provision of certain assistance. Please contact either the Pasco County Customer Service Center, 8731 Citizens Drive, New Port Richey, FL 34654, (727) 847-2411 (V) of the Pasco County Risk Management Office, 7536 State Street, New Port Richey, FL 34654, (727) 847-8028 (V) at least 7 days before your scheduled court appearance, or immediately upon receiving this notification if the time before the scheduled appearance is less than 7 days; if you are hearing or voice impaired, call 711. Dated this 16th day of June, 2026. TIFFANY & BOSCO, P.A. /s/ Kathryn I. Kasper, Esq. Anthony R. Smith, Esq. FL Bar #157147 Kathryn I. Kasper, Esq. FL Bar #621188 Attorneys for Plaintiff 1201 S. Orlando Ave, Suite 430 Winter Park, FL 32789 Telephone: (205) 930-5200 Facsimile: (407) 712-9201 June 19, 26, 2026 26-01422P

SECOND INSERTION

NOTICE OF ACTION IN THE CIRCUIT COURT OF THE SIXTH JUDICIAL CIRCUIT IN AND FOR PASCO COUNTY, FLORIDA CASE NO.: 2026CA000387CAAXWS LAKEVIEW LOAN SERVICING, LLC, Plaintiff, v. LANA DENISE EDWARDS, et al., Defendants. TO: Lana Denise Edwards 5601 Lima Drive Holiday, FL 34690 Lana Denise Edwards 1220 NW 12th St., Apt. 45 Gainesville, FL 32601 Unknown Spouse of Lana Denise Edwards 5601 Lima Drive Holiday, FL 34690 Unknown Spouse of Lana Denise Edwards 1220 NW 12th St., Apt. 45 Gainesville, FL 32601 Unknown Party in Possession 1 5601 Lima Drive Holiday, FL 34690 Unknown Party in Possession 2 5601 Lima Drive Holiday, FL 34690 YOU ARE HEREBY NOTIFIED that an action to foreclose a mortgage on the following described property in Pasco County, Florida: Lot 216, Less the East 20 feet thereof, of LA VILLA GARDENS UNIT TWO, according to plat thereof as recorded in Plat Book 12, Page 78 and 79, of the Public Records of Pasco County, Florida. has been filed against you and you are

required to serve a copy of your written defenses, if any, on Anthony R. Smith, Esquire, the Plaintiff's attorney, whose address is Tiffany & Bosco, P.A., 1201 S. Orlando Ave, Suite 430, Winter Park, FL 32789, on or before thirty (30) days from the date of first publication of this Notice, and file the original with the Clerk of this Court either before service on the Plaintiff's attorney or immediately thereafter; or a default will be entered against you for the relief demanded in the complaint. DUE ON OR BEFORE JULY 20TH, 2026 If you are a person with a disability who needs an accommodation in order to participate in this proceeding, you are entitled, at no cost to you, to the provision of certain assistance. Please contact: Public Information Dept., Pasco County Government Center, 7530 Little Rd., New Port Richey, FL 34654; Phone: 727.847.8110 (voice) in New Port Richey, 352.521.4274, ext 8110 (voice) in Dade City, Or 711 for the hearing impaired. Contact should be initiated at least seven days before the scheduled court appearance, or immediately upon receiving this notification if the time before the scheduled appearance is less than seven days. The court does not provide transportation and cannot accommodate such requests. Persons with disabilities needing transportation to court should contact their local public transportation providers for information regarding transportation services. WITNESS my hand and the seal of this Court this June 10, 2026. (SEAL) Nikki Alvarez-Sowles Pasco County Clerk & Comptroller Deputy Clerk: Haley Joyner June 19, 26, 2026 26-01375P

NOTICE OF ACTION IN THE CIRCUIT COURT OF THE SIXTH JUDICIAL CIRCUIT OF FLORIDA IN AND FOR PASCO COUNTY GENERAL JURISDICTION DIVISION CASE NO. 2025CA003022CAAXWS NAVY FEDERAL CREDIT UNION, Plaintiff, vs. WARREN PAUL, SR., et al., Defendant. To: ANY AND ALL UNKNOWN PARTIES CLAIMING BY, THROUGH, UNDER, AND AGAINST ESTATE OF MARY A PAUL A/K/A MARY ANNA PAUL, WHETHER SAID UNKNOWN PARTIES MAY CLAIM AN INTEREST AS SPOUSES, HEIRS, DEVISEES, GRANTEEES, OR OTHER CLAIMANTS ADDRESS: UNKNOWN LINDA DIAKITE KARRESSY, AS PERSONAL REPRESENTATIVE OF THE ESTATE OF MARY A PAUL A/K/A MARY ANNA PAUL 2804 KESSLER BLVD EAST DRIVE, INDIANAPOLIS, IN 46220 LAST KNOWN ADDRESS STATED, CURRENT RESIDENCE UNKNOWN YOU ARE HEREBY NOTIFIED that an action for Foreclosure of Mortgage on the following described property: LOT 1568, HOLIDAY LAKE ESTATES UNIT SIXTEEN, ACCORDING TO PLAT THEREOF AS RECORDED IN PLAT BOOK 10, PAGE 128, OF THE PUBLIC RECORDS OF PASCO COUNTY, FLORIDA. has been filed against you and you are required to file a copy of your written defenses, if any, to it on Curtis Wilson, Esq., McCalla Raymer Leibert Pierce, LLP, 225 East Robinson Street, Suite

155, Orlando, FL 32801 and file the original with the Clerk of the above-styled Court on or before JULY 20, 2026 or 30 days from the first publication, otherwise a Judgment may be entered against you for the relief demanded in the Complaint. If you are a person with a disability who needs any accommodation in order to participate in this proceeding, you are entitled, at no cost to you, to the provision of certain assistance. Please contact the Public Information Dept., Pasco County Government Center, 7530 Little Rd., New Port Richey, FL 34654; (727) 847-8110 (V) in New Port Richey; (352) 521-4274, ext 8110 (V) in Dade City, at least 7 days before your scheduled court appearance, or immediately upon receiving this notification if the time before the scheduled appearance is less than 7 days; if you are hearing impaired call 711. The court does not provide transportation and cannot accommodate for this service. Persons with disabilities needing transportation to court should contact their local public transportation providers for information regarding transportation services. WITNESS my hand and seal of this Court on the 16th day of June, 2026. NIKKI ALVAREZ-SOWLES, ESQ. CLERK OF COURT OF PASCO COUNTY As Clerk of the Court (SEAL) BY: Shakira Ramirez Pagan Deputy Clerk MCCALLA RAYMER LEIBERT PIERCE, LLP 225 East Robinson Street, Suite 155, Orlando, FL 32801 Phone: (407) 674-1850 Fax: (321) 248-0420 Email:AccountsPayables@mccalla.com 25-13302FL June 19, 26, 2026 26-01418P

SECOND INSERTION

NOTICE OF FORECLOSURE SALE IN THE CIRCUIT COURT OF THE SIXTH JUDICIAL CIRCUIT IN AND FOR PASCO COUNTY, FLORIDA GENERAL JURISDICTION DIVISION CASE NO. 2025CA003415CAAXWS PLANET HOME LENDING, LLC, Plaintiff, vs. SCOTT DOUGLAS LUDLAM, et al. Defendant(s). NOTICE IS HEREBY GIVEN pursuant to a Final Judgment of Foreclosure dated June 03, 2026, and entered in 2025CA003415CAAXWS of the Circuit Court of the SIXTH Judicial Circuit in and for Pasco County, Florida, wherein PLANET HOME LENDING, LLC is the Plaintiff and SCOTT DOUGLAS LUDLAM; SARAH-ANNE ELLA LUDLAM; MORTGAGE ELECTRONIC REGISTRATION SYSTEMS, INC. AS NOMINEE FOR NEW AMERICAN FUNDING, LLC are the Defendant(s). Nikki Alvarez-Sowles, Esq. as the Clerk of the Circuit Court will sell to the highest and best bidder for cash at www.pasco.realforeclose.com, at 11:00 AM, on July 07, 2026, the following described property as set forth in said Final Judgment, to wit: LOT 75-A AND WEST 8 FEET OF LOT 75-B, KNOLLWOOD VIL-LAGE II, ACCORDING TO THE PLAT THEREOF, RECORDED IN PLAT BOOK 7, PAGE(S) 115, OF THE PUBLIC RECORDS OF PASCO COUNTY, FLORIDA. Property Address: 4928 LAKE RIDGE LANE, HOLIDAY, FL 34690 Any person claiming an interest in the surplus from the sale, if any, other than the property owner as of the date of the

lis pendens must file a claim in accordance with Florida Statutes, Section 45.031. IMPORTANT AMERICANS WITH DISABILITIES ACT: If you are a person with a disability who needs an accommodation in order to participate in this proceeding, you are entitled, at no cost to you, to the provision of certain assistance. Please contact: Public Information Dept., Pasco County Government Center, 7530 Little Rd., New Port Richey, FL 34654; Phone: 727.847.2411 (voice) in New Port Richey, 727.847.8028 (voice) in Dade City, Or 711 for the hearing impaired. Contact should be initiated at least seven days before the scheduled court appearance, or immediately upon receiving this notification if the time before the scheduled appearance is less than seven days. The court does not provide transportation and cannot accommodate such requests. Persons with disabilities needing transportation to court should contact their local public transportation providers for information regarding transportation services. Dated this 16 day of June, 2026. ROBERTSON, ANSCHUTZ, SCHNEID, CRANE & PARTNERS, PLLC Attorney for Plaintiff 6409 Congress Ave., Suite 100 Boca Raton, FL 33487 Telephone: 561-241-6901 Facsimile: 561-997-6909 Service Email: flmail@raslg.com By: \S\Danielle Salem Danielle Salem, Esquire Florida Bar No. 0058248 Communication Email: dsalem@raslg.com 25-340522 - NaP June 19, 26, 2026 26-01421P

SECOND INSERTION

NOTICE OF FORECLOSURE SALE IN THE CIRCUIT COURT OF THE SIXTH JUDICIAL CIRCUIT IN AND FOR PASCO COUNTY, FLORIDA GENERAL JURISDICTION DIVISION CASE NO. 2025CA002603CAAXWS U.S. BANK NATIONAL ASSOCIATION, Plaintiff, vs. SOLIMAR DELEE ACEVEDO, et al. Defendant(s). NOTICE IS HEREBY GIVEN pursuant to a Final Judgment of Foreclosure dated May 07, 2026, and entered in 2025CA002603CAAXWS of the Circuit Court of the SIXTH Judicial Circuit in and for Pasco County, Florida, wherein U.S. BANK NATIONAL ASSOCIATION is the Plaintiff and SOLIMAR DELEE ACEVEDO; UNITED STATES OF AMERICA ON BEHALF OF THE SECRETARY OF HOUSING AND URBAN DEVELOPMENT are the Defendant(s). Nikki Alvarez-Sowles, Esq. as the Clerk of the Circuit Court will sell to the highest and best bidder for cash at www.pasco.realforeclose.com, at 11:00 AM, on July 09, 2026, the following described property as set forth in said Final Judgment, to wit: LOT 1032, ALOHA GARDENS UNIT NINE, ACCORDING TO THE PLAT THEREOF, AS RECORDED IN PLAT BOOK 11, PAGES 34 THROUGH 36, INCLUSIVE, OF THE PUBLIC RECORDS OF PASCO COUNTY, FLORIDA. Property Address: 3518 CHAUNCY RD, HOLIDAY, FL 34691 Any person claiming an interest in the surplus from the sale, if any, other than

the property owner as of the date of the lis pendens must file a claim in accordance with Florida Statutes, Section 45.031. IMPORTANT AMERICANS WITH DISABILITIES ACT: If you are a person with a disability who needs an accommodation in order to participate in this proceeding, you are entitled, at no cost to you, to the provision of certain assistance. Please contact: Public Information Dept., Pasco County Government Center, 7530 Little Rd., New Port Richey, FL 34654; Phone: 727.847.2411 (voice) in New Port Richey, 727.847.8028 (voice) in Dade City, Or 711 for the hearing impaired. Contact should be initiated at least seven days before the scheduled court appearance, or immediately upon receiving this notification if the time before the scheduled appearance is less than seven days. The court does not provide transportation and cannot accommodate such requests. Persons with disabilities needing transportation to court should contact their local public transportation providers for information regarding transportation services. Dated this 12 day of June, 2026. ROBERTSON, ANSCHUTZ, SCHNEID, CRANE & PARTNERS, PLLC Attorney for Plaintiff 6409 Congress Ave., Suite 100 Boca Raton, FL 33487 Telephone: 561-241-6901 Facsimile: 561-997-6909 Service Email: flmail@raslg.com By: \S\Danielle Salem Danielle Salem, Esquire Florida Bar No. 0058248 Communication Email: dsalem@raslg.com 25-328631 - MaS June 19, 26, 2026 26-01415P

NOTICE OF FORECLOSURE SALE IN THE CIRCUIT COURT OF THE SIXTH JUDICIAL CIRCUIT IN AND FOR PASCO COUNTY, FLORIDA GENERAL JURISDICTION DIVISION CASE NO. 2026CA000334CAAXWS NATIONSTAR MORTGAGE LLC, Plaintiff, vs. 2332 CD LLC, et al. Defendant(s). NOTICE IS HEREBY GIVEN pursuant to a Final Judgment of Foreclosure dated May 12, 2026, and entered in 2026CA000334CAAXWS of the Circuit Court of the SIXTH Judicial Circuit in and for Pasco County, Florida, wherein NATIONSTAR MORTGAGE LLC is the Plaintiff and 2332 CD LLC; ANGELIA KAY TRAPP A/K/A ANGELIA TRAPP; MITCHELL LYNN TRAPP A/K/A MITCHELL L. TRAPP are the Defendant(s). Nikki Alvarez-Sowles, Esq. as the Clerk of the Circuit Court will sell to the highest and best bidder for cash at www.pasco.realforeclose.com, at 11:00 AM, on July 07, 2026, the following described property as set forth in said Final Judgment, to wit: LOT 1032, ALOHA GARDENS LOT 162, ORANGEWOOD VIL-LAGE, UNIT THREE, ACCORDING TO THE PLAT THEREOF AS RECORDED IN PLAT BOOK 8, PAGE 13, OF THE PUBLIC RECORDS OF PASCO COUNTY, FLORIDA Property Address: 2332 CHAN-CERY DRIVE, HOLIDAY, FL 34690 Any person claiming an interest in the surplus from the sale, if any, other than the property owner as of the date of the

lis pendens must file a claim in accordance with Florida Statutes, Section 45.031. IMPORTANT AMERICANS WITH DISABILITIES ACT: If you are a person with a disability who needs an accommodation in order to participate in this proceeding, you are entitled, at no cost to you, to the provision of certain assistance. Please contact: Public Information Dept., Pasco County Government Center, 7530 Little Rd., New Port Richey, FL 34654; Phone: 727.847.2411 (voice) in New Port Richey, 727.847.8028 (voice) in Dade City, Or 711 for the hearing impaired. Contact should be initiated at least seven days before the scheduled court appearance, or immediately upon receiving this notification if the time before the scheduled appearance is less than seven days. The court does not provide transportation and cannot accommodate such requests. Persons with disabilities needing transportation to court should contact their local public transportation providers for information regarding transportation services. Dated this 12 day of June, 2026. ROBERTSON, ANSCHUTZ, SCHNEID, CRANE & PARTNERS, PLLC Attorney for Plaintiff 6409 Congress Ave., Suite 100 Boca Raton, FL 33487 Telephone: 561-241-6901 Facsimile: 561-997-6909 Service Email: flmail@raslg.com By: \S\Danielle Salem Danielle Salem, Esquire Florida Bar No. 0058248 Communication Email: dsalem@raslg.com 25-358382 - MaS June 19, 26, 2026 26-01416P

SECOND INSERTION

NOTICE OF SALE IN THE COUNTY COURT FOR THE SIXTH JUDICIAL CIRCUIT IN AND FOR PASCO COUNTY, FLORIDA CIVIL DIVISION Case No. 25-CC-003223 FAIRWAY HOMES AT MEADOW OAKS HOMEOWNERS ASSOCIATION, INC Plaintiff, vs. LASHERI V. POWELL, and UNKNOWN TENANT(S), Defendants. Notice is hereby given that pursuant to Paragraph 5 of the Final Judgment of Foreclosure entered in the case pending in the County Court of the Sixth Judicial Circuit in and for Pasco County, Florida, Case No. 25-CC-003223 the Clerk of the Court, Pasco County, shall sell the property situated in said county, described as: Lot 6, Block I, MEADOW OAKS PARCELS I & Q, according to the map or plat thereof as recorded in Plat Book 36, Page 6, Public Records of Pasco County, Florida. PARCEL ID NO.: 34-24-17-0070-00100-0060 ("Property") Property Address: 13651 Meadow Green Lane, Hudson, Florida 34669 at public sale, to the highest and best bidder for cash at 11:00 a.m. on JULY 27, 2026. The sale shall be conducted online at http://www.pasco.realforeclose.com. Any person claiming an interest in the surplus proceeds from the sale, if any, other than the property

owner as of the date of the notice, must file a claim within 60 days after the sale. If you are a person with a disability who needs any accommodation in order to participate in this proceeding, you are entitled, at no cost to you, to the provision of certain assistance. Please contact either the Pasco County Customer Service Center, 8731 Citizens Drive, New Port Richey, FL 34654, (727) 847-2411 (V) or the Pasco County Risk Management Office, 7536 State Street, New Port Richey, FL 34654, (727) 847-8028 (V) at least 7 days before your scheduled court appearance, or immediately upon receiving this notification if the time before the scheduled appearance is less than 7 days; if you are hearing or voice impaired, call 711. Dated this 16th day of June 2026. RABIN PARKER GURLEY, P.A. 2653 McCormick Drive Clearwater, Florida 33759 Telephone: (727)475-5535 Facsimile: (727)723-1131 For Electronic Service: pleadings@rpglaw.com Counsel for Plaintiff By: /s/ Jennifer Schick. Monique E. Parker, Florida Bar No. 0112519 Jennifer Schick, Florida Bar No. 195790 10471-012 June 19, 26, 2026 26-01420P

SUBSCRIBE TO THE BUSINESS OBSERVER Call: (941) 362-4848 or go to: www.businessobserverfl.com Business Observer

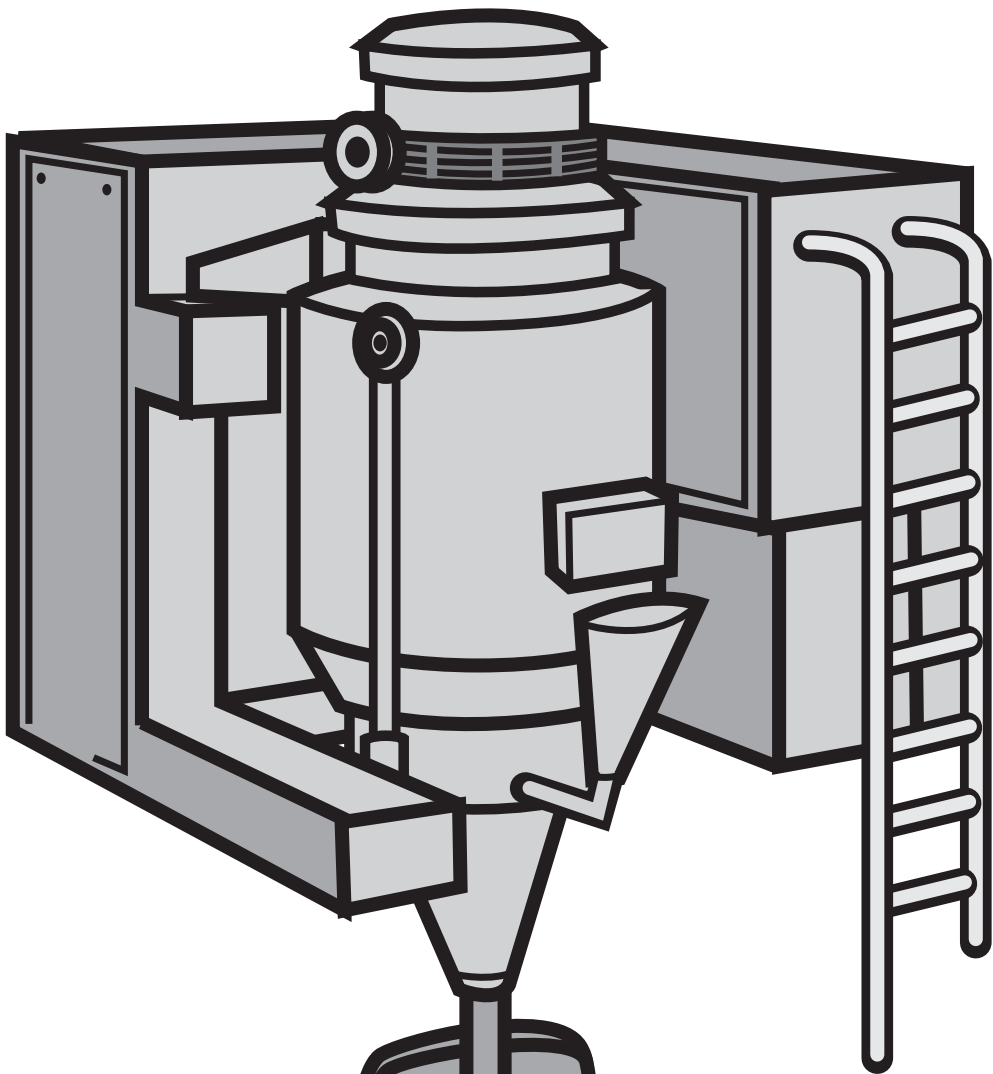

# TOM SMITH AND HIS INCREDIBLE BREAD MACHINE

**By R.W. Grant**

Illustrations by Austin McKinley

This is the legend of a man whose name  
Was a household word: a man whose fame  
Burst on the world like an atom bomb.  
Smith was his last name; first name: Tom.

The argument goes on today.  
"He was a villain," some will say.  
"No! A hero!" others declare.  
Or was he both? Well, I despair;  
The fight will last 'til kingdom come;  
Was Smith a hero? Or was Smith a bum?  
So, listen to the story and it's up to you  
To decide for yourself as to which is true!

Now, Smith, an inventor, had specialized  
In toys. So people were surprised  
When they found that he instead  
Of making toys, was baking bread!  
The news was flashed by CBS  
Of his incredible success.  
Then NBC jumped in in force,  
Followed by the Times, of course.  
The reason for their rapt attention,  
The nature of his new invention,  
The way to make bread he'd conceived  
Cost less than people could believe!  
And not just make it! This device  
Could in addition wrap and slice!  
The price per loaf, one loaf or many:  
The miniscule sum of under one penny!

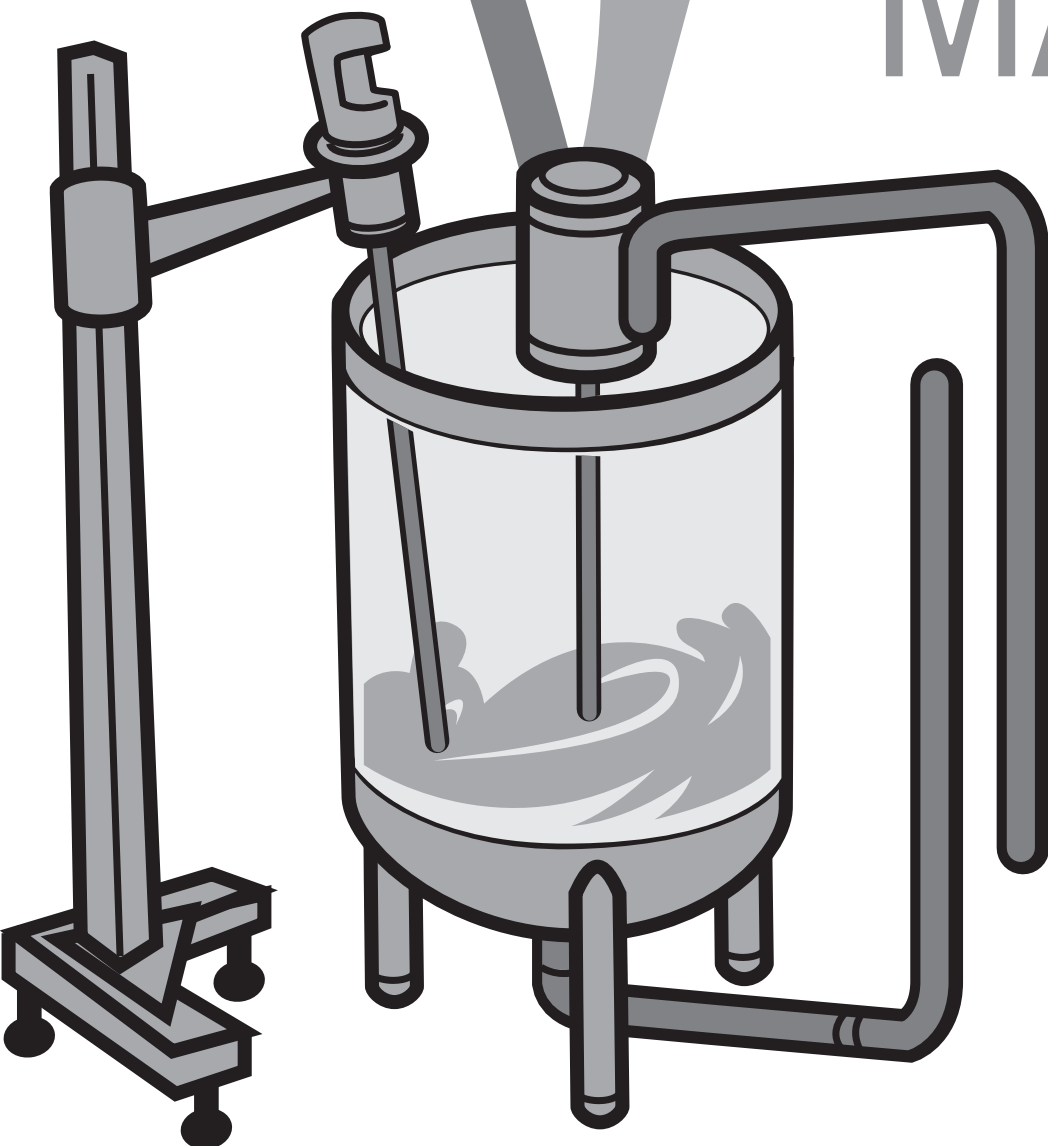

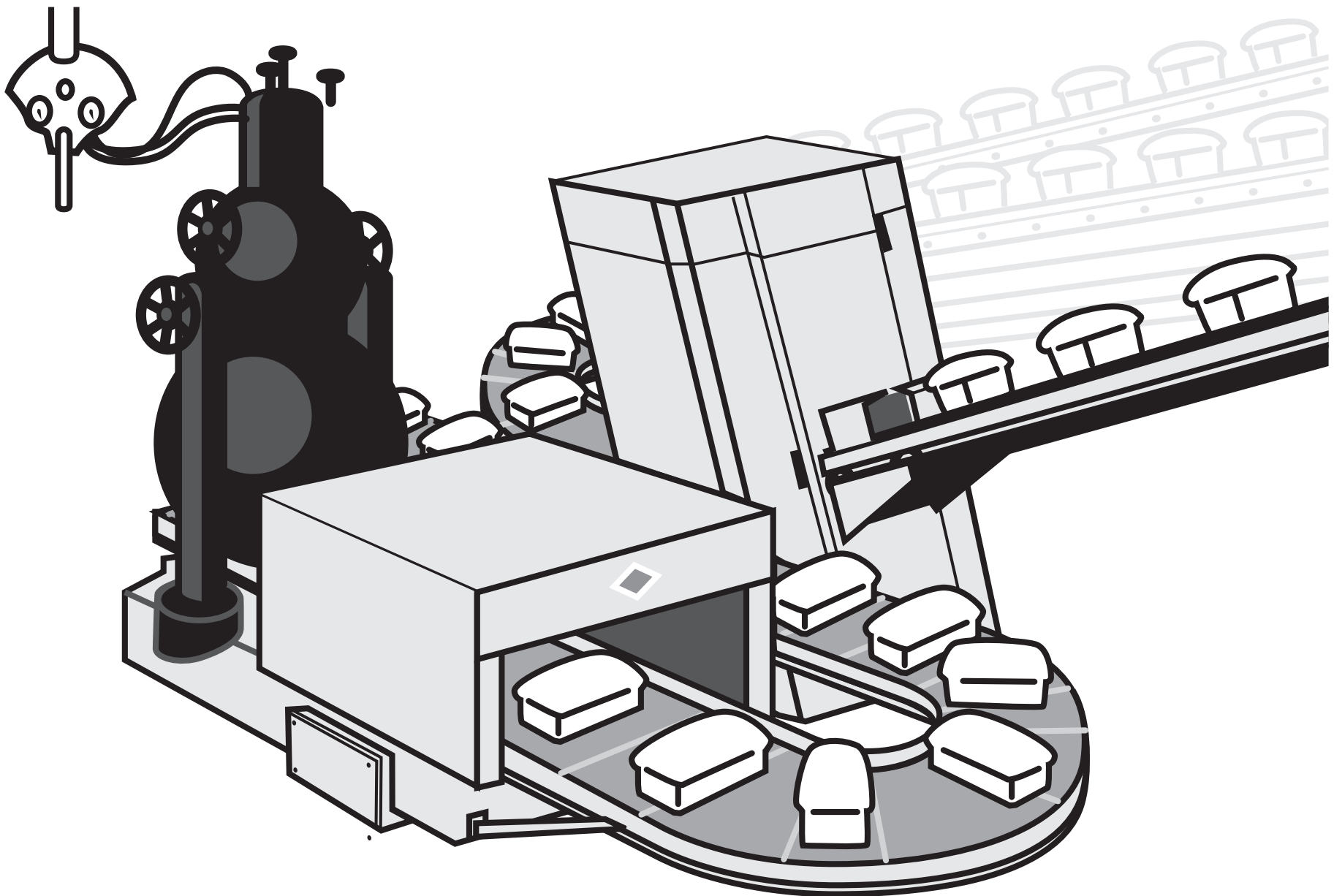

Can you imagine what this meant?  
Can you comprehend the consequent?  
The first time yet the world well fed!  
And all because of Tom Smith's bread!

Not the last to see the repercussions  
Were the Red Chinese, and, of course, the  
Russians,  
For Capitalist bread in such array

Threw the whole red block into black dis-  
may!  
Nonetheless, the world soon found  
That bread was plentiful the world  
around.  
Thanks to Smith and all that bread,  
A grateful world was at last well fed!

But isn't it a wondrous thing  
How quickly fame is flown?  
Smith, the hero of today  
Tomorrow, scarcely known!  
Yes, the fickle years passed by.  
Smith was a billionaire.

But Smith himself was now forgot,  
Though bread was everywhere.  
People, asked from where it came,  
Would very seldom know.

They would simply eat and ask,  
'Was not it always so?'

However, Smith cared not a bit,  
For millions ate his bread,  
And "Everything is fine," thought he.  
"I'm rich and they are fed!"

Everything was fine, he thought?  
He reckoned not with fate.  
Note the sequence of events  
Starting on the date  
On which inflation took its toll,  
And to a slight extent,  
The price on every loaf increased:  
It went to one full cent!

A sharp reaction quickly came.  
People were concerned.  
White House aide expressed dismay.  
Then the nation learned  
That Russia lodged a sharp protest.  
India did the same.  
"Exploitation of the Poor!"  
Yet, who was there to blame?

And though the clamor ebbed and flowed,  
All that Tom would say  
Was that it was but foolish talk.  
Which soon would die away.  
And it appeared that he was right.  
Though on and on it ran,  
The argument went 'round and 'round  
But stopped where it began.

There it stopped, and people cried,  
"For heaven's sake, we can't decide!  
It's relative! Beyond dispute,  
There's no such thing as 'absolute'!  
And though we try with all our might,  
Since nothing's ever black or white,  
All that we can finally say is  
'Everything one shade of grey is!'  
So people cried out, "Give us light!  
We can't tell what's wrong from right!"

To comprehend confusion,  
We seek wisdom at its source.  
To whom, then did the people turn?  
The Intellectuals, of course!

And what could be a better time  
For them to take the lead,  
Than at their International Conference  
On Inhumanity and Greed.  
For at this weighty conference,  
Once each year we face  
The moral conscience of the world—  
Concentrated in one place.

At that mighty conference were  
A thousand, more or less,  
Of intellectuals and bureaucrats,  
And those who write the press.  
And from Yale and Harvard  
The professors; all aware  
The fate of Smith would now be known.  
Excitement filled the air!

"The time has come," the chairman said  
"To speak of many things:  
Of duty, bread and selfishness,  
And the evil that it brings.  
For, speaking thus we can amend  
That irony of fate  
That gives to unenlightened minds  
The power to create.



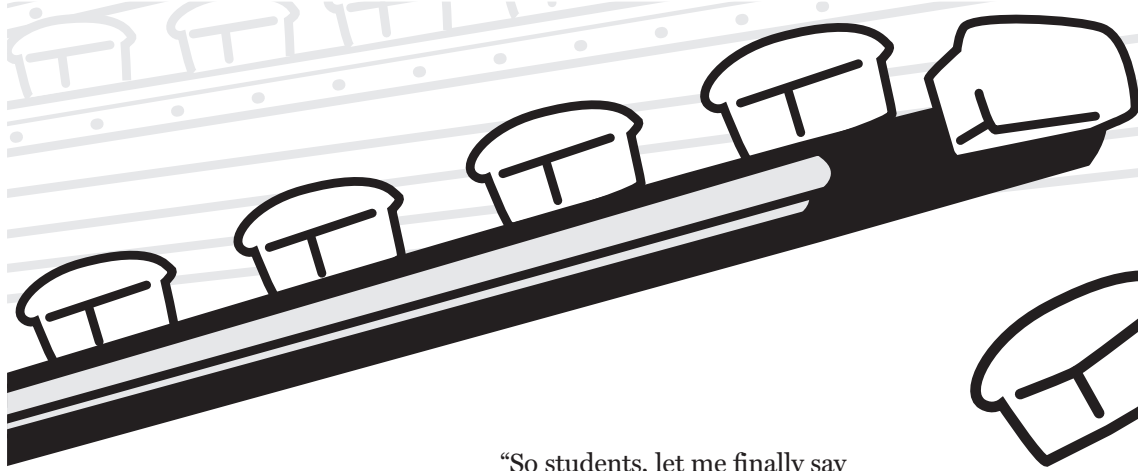

“Since reason tells us that it can’t,  
Therefore let us start  
Not by thinking with the mind,  
But only with the heart!  
Since we believe in people, then,”  
At last the chairman said,  
“We must meet our obligation  
To see that they are fed!”

And so it went, one by one,  
Denouncing private greed;  
Denouncing those who’d profit thus  
From other people’s need!

Then, suddenly each breath was held,  
For there was none more wise  
Than the nation’s foremost Pundit  
Who now rose to summarize:

“My friends,” he said, (they all  
exhaled)  
“We see in these events  
The flouting of the Higher Law—  
And its consequence.  
We must again remind ourselves  
Just why mankind is cursed:  
Because we fail to realize  
Society comes first!

“Smith placed himself above the  
group  
To profit from his brothers.  
He failed to see the Greater Good,  
Is Service, friends, to Others!”

With boldness and with vision,  
then,  
They ratified the motion  
To dedicate to all mankind  
Smith’s bread-and their devotion!

The conference finally ended.  
It had been a huge success.  
The intellectuals had spoken.  
Now others did the rest.

The professors joined in all the  
fuss,  
And one was heard to lecture thus:  
(For clarity, he spoke in terms  
Of Mother Nature, birds and worms):

“That early birds should get the worm  
Is clearly quite unfair.  
Wouldn’t it much nicer be  
If all of them would share?  
But selfishness and private greed

Seem part of nature’s plan,  
Which Mother Nature has decreed  
For bird. But also Man?  
The system which I question now,  
As you are well aware,  
(I’m sure you’ve heard the term  
before  
Is Business, Laissez-Faire!

“So students, let me finally say  
That we must find a nobler way.  
So, let us fix the race that all  
May finish side-by-side;  
The playing field forever flat,  
The score forever tied.  
To achieve this end, of course,  
We turn to government-and force.  
So, if we have to bring Smith do  
As indeed we should,  
I’m sure you will agree with me,  
It’s for the Greater Good!”

Comments in the nation’s press  
Now scorned Smith and his plunder:  
“What right had he to get so rich  
On other people’s hunger?”  
A prize cartoon depicted Smith  
With fat and drooping jowls  
Snatching bread from hungry babes,  
Indifferent to their howls.

One night, a TV star cried out,  
“Forgive me if I stumble,  
But I don’t think, I kid you not,  
That Smith is very humble!”  
Growing bolder, he leaped up,

(Silencing the cheers)  
“Humility!” he cried to all—  
And then collapsed in tears!

The clamor rises all about;  
Now hear the politician shout:  
“What’s Smith done, so rich to be?  
Why should Smith have more than thee?  
So, down with Smith and all his greed;  
I’ll protect your right to need!”

Then Tom found to his dismay  
That certain businessmen would say,  
“The people now should realize  
It’s time to cut Smith down to size,  
For he’s betrayed his public trust  
(And taken all that bread from us!)”

Well, since the Public does come first,  
It could not be denied  
That in matters such as this,  
The public must decide.  
So, SEC became concerned,  
And told the press what it had learned:  
“It’s obvious that he’s guilty  
—Of what we’re not aware—  
Though actually and factually  
We’re sure there’s something there!”

And Antitrust now took a hand.  
Of course it was appalled  
At what it found was going on.  
The “bread trust” it was called.

“Smith has too much crust,”  
they said. “A deplorable condition  
That Robber Barons profit thus  
From cutthroat competition!”

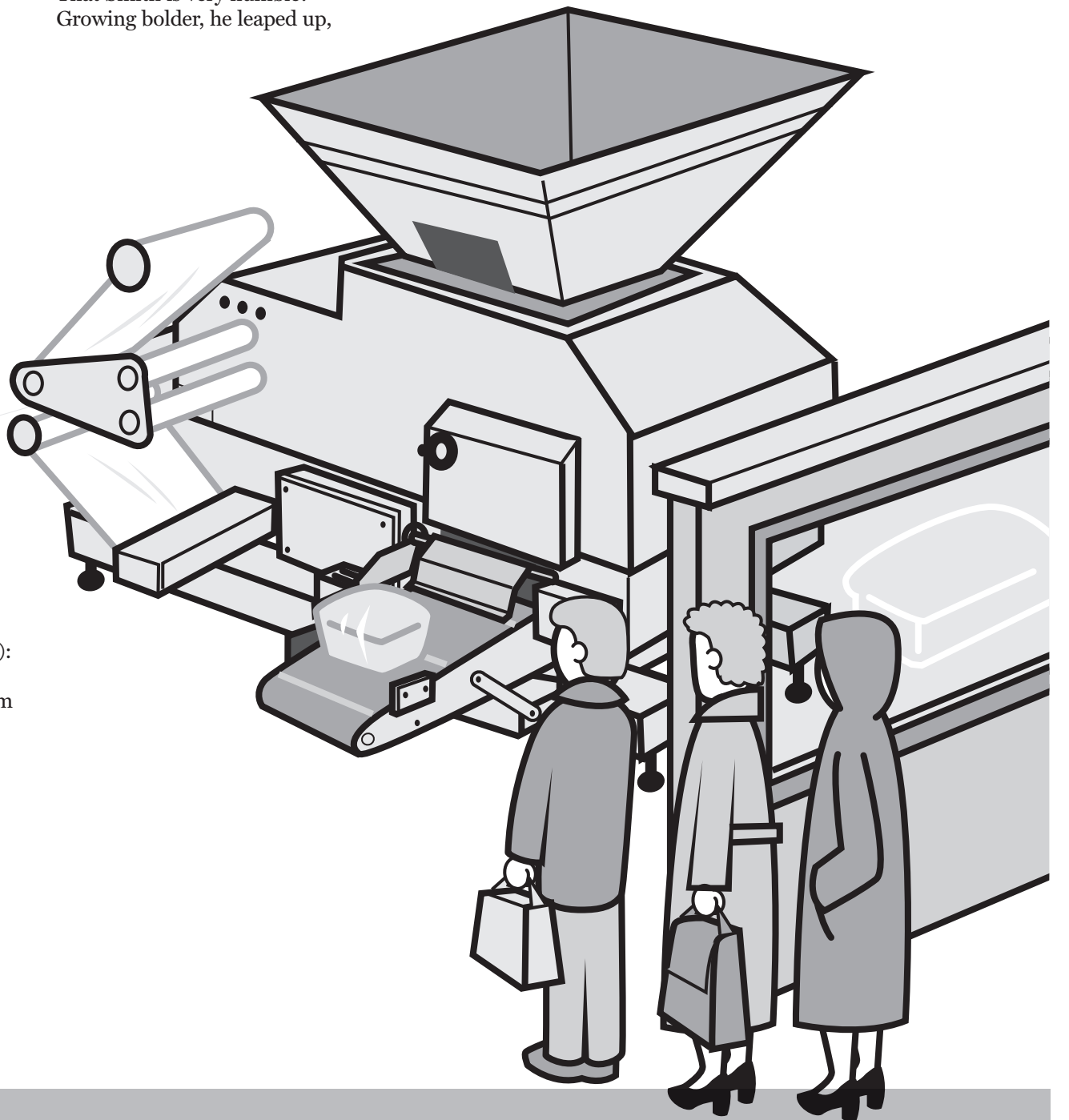

WELL!

This was getting serious!  
So Smith felt that he must  
Have a friendly interview  
With SEC and "Trust."  
So, hat in hand, he went to them.  
They'd surely been misled;  
No rule of law had he defied.  
But then their lawyer said:

"The rule of law, in complex times,  
Has proved itself deficient.  
We much prefer the rule of men.  
It's vastly more efficient.

"So, nutshell-wise, the way it is,  
The law is what we say it is!

"So, let me state the present rules,"  
The lawyer then went on,  
"These very simple guidelines  
You can rely upon:  
You're gouging on your prices  
If you charge more than the rest.  
But it's unfair competition  
If you think you can charge less!  
"A second point that we would make,  
To help avoid confusion:  
Don't try to charge the same amount,  
For that would be collusion!

"You must compete—but not too much.  
For if you do, you see,  
Then the market would be yours—  
And that's monopoly!  
Oh, don't dare monopolize!  
We'd raise an awful fuss,  
For that's the greatest crime of all!  
(Unless it's done by us!)"

"I think I understand," said Tom.  
"And yet, before I go,  
How does one get a job like yours?  
I'd really like to know!"

The lawyer rose then with a smile;  
"I'm glad you asked," said he.  
"I'll tell you how I got my start  
And how it came to be."

(His secretaries gathered 'round  
As their boss did thus expound.)

*"When I was a lad going off to school,  
I was always guided by this golden rule:  
Let others take the lead in things, for  
heaven's sake,  
So if things go wrong—why, then it's their  
mistake!"*  
(*So if things go wrong—why, then it's their  
mistake!*)

*"Following this precept it came to pass  
I became the president of my senior class.  
Then on to college where my profs extolled  
The very same theory from the very same  
mold!"*  
(*The very same theory from the very same  
mold!*)

*"Let others take the chances, and I would  
go along.  
Then I would let them know where they all  
went wrong!  
So successful was my system that then  
indeed,  
I was voted most likely in my class to suc-  
ceed!"*

*(He was voted most likely in his class to  
succeed!)*

*"Then out into the world I went, along  
with all the rest,  
Where I put my golden rule to the ulti-  
mate test.  
I avoided all of commerce at whatever the  
cost—  
And because I never ventured, then I also  
never lost!"*  
(*And because he never ventured, then he  
also never lost!*)

*"With this unblemished record then, I  
quickly caught the eye  
Of some influential people 'mongst the  
powers on high.*

*And so these many years among the  
mighty I have sat,  
Having found my niche as a bureaucrat!"*  
(*Having found his niche as a bureaucrat'*)

*"To be a merchant prince has never been  
my goal,  
For I'm qualified to play a more impor-  
tant role:  
Since I've never failed in business, this of  
course assures  
That I'm qualified beyond dispute to now  
run yours!"*  
(*That he's qualified beyond dispute to now  
run yours!*)

"Thanks; that clears it up," said Tom.

The lawyer said, "I'm glad!  
We try to serve the public good.  
We're really not so bad!

"Now, in disposing of this case,  
If you wish to know just how,  
Go up to the seventh floor;  
We're finalizing now!"

So, Tom went to the conference room  
Up on the seventh floor.  
He raised his hand, about to knock,  
He raised it—but no more—  
For what he overheard within  
Kept him outside the door!  
A sentence here, a sentence there—  
Every other word—  
He couldn't make it out (he hoped),  
For this is what he heard:

"Mumble, mumble, let's not fumble!  
Mumble, mumble, what's the charge?  
Grumble, grumble, he's not humble?  
Private greed? Or good of all?"

"Public Interest, Rah! Rah! Rah!  
Business, Business, Bah! Bah! Bah!

"Say, now this now we confess  
That now this now is a mess!  
Well now, what now do we guess?  
Discharge? Which charge would be best?"

"How 'bout 'Greed and Selfishness'?  
Oh, wouldn't that be fun?  
It's vague enough to trip him up  
No matter what he's done!

"We don't produce or build a thing!  
But before we're through,  
We allow that now we'll show Smith how  
We handle those who do!

"We serve the public interest;  
We make up our own laws;  
Oh, golly gee, how selflessly  
We serve the public cause!

"For we're the ones who make the rules  
At 'Trust and SEC,  
So bye and bye we'll get that guy;  
Now, what charge will it be?

"Price too high? Or price too low?  
Now, which charge will we make?  
Well, we're not loath to charging both  
When public good's at stake!

"But can we go one better?  
How 'bout monopoly?  
No muss, no fuss, oh clever us!  
Right-O! Let's charge all three!

"But why stop here? We have one more!  
Insider Trading! Number four!  
We've not troubled to define  
This crime in any way so,  
This allows the courts to find  
Him guilty 'cause we say so!"

So, that was the indictment.  
Smith's trial soon began.  
It was a cause célèbre  
Which was followed' cross the land.  
In his defense Tom only said,  
"I'm rich, but all of you are fed!  
Is that bargain so unjust  
That I should now be punished thus?"

Tom fought it hard all the way.  
But it didn't help him win.  
The jury took but half an hour  
To bring this verdict in:

"Guilty! Guilty! We agree!  
He's guilty of this plunder!  
He had no right to get so rich  
On other people's hunger!"

"Five years in jail!" the judge then said.  
"You're lucky it's not worse!  
Robber Barons must be taught  
Society Comes First!  
As flies to wanton boys," he leered,  
"Are we to men like these!  
They exploit us for their sport!  
Exploit us as they please!"

The sentence seemed a bit severe,  
But mercy was extended.  
In deference to his mother's pleas,  
One year was suspended.  
And what about the Bread Machine?  
Tom Smith's little friend?  
Broken up and sold for scrap.  
Some win. Some lose. The end.

## EPILOGUE

Now, bread is baked by government.  
And as might be expected,  
Everything is well controlled—  
The public well protected.

True, loaves cost ten dollars each.  
But our leaders do their best.  
The selling price is half a cent.  
Taxes pay the rest!

