

# Public Notices

## SARASOTA COUNTY LEGAL NOTICES

### --- PUBLIC SALES ---

FIRST INSERTION	FIRST INSERTION
<b>Notice Under Fictitious Name Law According to Florida Statute Number 865.09</b> NOTICE IS HEREBY GIVEN that the undersigned, desiring to engage in business under the Fictitious Name of GRS CAR DETAILING located at 3013 clementine ct unit 3314 in the City of sarasota, Sarasota, FL 34240 intends to register the said name with the Division of Corporations of the Department of State, Tallahassee, Florida. Dated this 2nd day of May, 2026 ronald colmenarez June 26, 2026	<b>Notice Under Fictitious Name Law According to Florida Statute Number 865.09</b> NOTICE IS HEREBY GIVEN that the undersigned, desiring to engage in business under the Fictitious Name of Neat N Sweet Cleaning Co. located at 5041 Richmond Ter in the City of North Port, Sarasota, FL 34287 intends to register the said name with the Division of Corporations of the Department of State, Tallahassee, Florida. Dated this 19th day of June, 2026 Ansley Endicott June 26, 2026

FIRST INSERTION																		
<b>NOTICE OF PUBLIC SALE</b> Notice of Public Auction for monies due on storage units. The auction will be held on JULY 16, 2026 at or after 8:00 am and will continue until finished. Units are said to contain household items. Property sold under Florida Statute 83.806. The names of whose units will be sold are as follows. 7850 N. Tamiami Trail Sarasota FL 34243 <table border="1"><thead><tr><th>NAME</th><th>UNIT</th><th>BALANCE</th></tr></thead><tbody><tr><td><b>MATTHEW VALLIO</b></td><td>2098-00</td><td>459.9</td></tr><tr><td><b>Joshua Young</b></td><td>1039</td><td>499.9</td></tr><tr><td><b>joseph gates</b></td><td>2213</td><td>539.9</td></tr><tr><td><b>Robert Mannion</b></td><td>1225</td><td>469.9</td></tr><tr><td><b>Dawn Crawford</b></td><td>1520</td><td>469.9</td></tr></tbody></table> Dated this 26th day of June, 2026 June 26; July 3, 2026	NAME	UNIT	BALANCE	<b>MATTHEW VALLIO</b>	2098-00	459.9	<b>Joshua Young</b>	1039	499.9	<b>joseph gates</b>	2213	539.9	<b>Robert Mannion</b>	1225	469.9	<b>Dawn Crawford</b>	1520	469.9
NAME	UNIT	BALANCE																
<b>MATTHEW VALLIO</b>	2098-00	459.9																
<b>Joshua Young</b>	1039	499.9																
<b>joseph gates</b>	2213	539.9																
<b>Robert Mannion</b>	1225	469.9																
<b>Dawn Crawford</b>	1520	469.9																

FIRST INSERTION	FIRST INSERTION
<b>Notice Under Fictitious Name Law According to Florida Statute Number 865.09</b> NOTICE IS HEREBY GIVEN that the undersigned, desiring to engage in business under the Fictitious Name of DA Detail Force located at 5058 old Bradenton Rd in the City of Sarasota, Sarasota, FL 34234 intends to register the said name with the Division of Corporations of the Department of State, Tallahassee, Florida. Dated this 19th day of June, 2026 LS Pro Construction Inc Andrea Sorossy June 26, 2026	<b>Notice Under Fictitious Name Law According to Florida Statute Number 865.09</b> NOTICE IS HEREBY GIVEN that the undersigned, desiring to engage in business under the Fictitious Name of Income Care Plan Insurance Agency located at 10217 Morning Mist Lane in the City of Sarasota, Sarasota, FL 34241 intends to register the said name with the Division of Corporations of the Department of State, Tallahassee, Florida. Dated this 24th day of June, 2026 Risk & Tax Mitigation Solutions, Inc. John Marshall, President June 26, 2026

FIRST INSERTION
<b>NOTICE OF PUBLIC SALE</b> Pursuant to the Florida Self Storage Lien Act, the owner of a self-storage facility has a lien upon all personal property located at the self-service storage facility for rent or other charges incurred for the storage of the personal property. Due to the failure to pay the rent, the owner is enforcing its lien and intends to sell or otherwise dispose of the personal property located in the rented spaces listed in this notice. THIS NOTICE IS BEING PROVIDED PURSUANT TO FLORIDA STATE LAW BEFORE the sale, the tenants listed may pay the amount necessary to satisfy the lien and the reasonable expenses incurred to redeem the personal property. ADVERTISEMENT OF SALE: Notice is hereby given that the personal property located in the following storage units will be sold by competitive bidding. Facility Name: iStorage - 7011 - Sarasota Facility Address: 6791 28th Street Circle East, Sarasota, FL 34243 US Facility Phone: 1+ (941) 265-7401 Description: Entire contents of unit consisting of, but not limited to: Mary Oakes - M0551 - Dresser, Boxes, Microwave, Mirror; Steven Culbreath - M2749 - Boxes, Speakers, Electronics; Aiyana Maat - M2993 - Sofas and Chair; Scott Slaughter - M1620 - Furniture, Shelves, Household Goods; Melissa Rainey - M0447 - Washer, Dryer, Boxes, Household Goods. Bidding: All bidding will take place online at StorageTreasuries.com on July 13, 2026, at 11:00am. Property will be sold to the highest bidder. June 26; July 3, 2026

FIRST INSERTION
<b>ADVERTISEMENT OF SALE</b> NOTICE IS HEREBY GIVEN that the undersigned intends to sell the personal property described below to enforce a lien imposed on said property under The Florida Self Storage Facility Act Statutes (Section 83.801-83.809). The undersigned will sell at public sale by competitive bidding on Tuesday the 14th day of July, 2026 at 10:00 AM, at lockerfox.com. Said property has been stored and is located at: Space Shop Self Storage, 3323 17th St, Sarasota, FL, 34235. Mulvin, Jamie Tools, Frige, Mattress, Boxes; Powers, Susan Bikes And Bike Accessories, Suitcases, Alcohol; Kelley, Michael Tools, Artwork, Furniture, Clothes; OCHOA, YANIRA Fishing Rods, Dresser, Suitcase; Roobins, Pierre Tools; MELENDEZ ALLENDE, BRENDA Air Conditioners, Chairs, TV, Boxes; Pajaro Rolando, Daniel Table, Desk, Shoes, Bins, Tennis Rackets; Fairo, James Table, Furniture, Boxes and Totes; Pereira, Gerardo Alcohol, Industrial Kitchen Equipment, Countertops; miles, kathy Bags, Clothes, Boxes; Millard, Rachael Boxes, Appliances, Electronics, Furniture, Household Goods, Kids toys CAR AND MOTORCYCLES ARE NOT FOR SALE Sale is subject to cancellation in the event of settlement between owner and obligated party. June 26; July 3, 2026

FIRST INSERTION								
<b>NOTICE OF PUBLIC SALE OF PERSONAL PROPERTY</b> Please take notice Smart Stop Self Storage located at 1027 N Washington Blvd, Sarasota, FL 34236 intends to hold an auction of the goods stored in the following units to satisfy the lien of the owner. The sale will occur as an online auction via www.storage-treasuries.com on 7/16/2026 at 2:30 PM. Contents include personal property along with the described belongings to those individuals listed below: <table border="1"><tbody><tr><td><b>Unit 1180 Gary Sligar</b></td><td><b>Boxes, Totes, Clothes, Art, Golf Clubs</b></td></tr><tr><td><b>Unit 2230 Eileen Reed</b></td><td><b>Bags, Clothes</b></td></tr><tr><td><b>Unit 3209 Jasmine Locke</b></td><td><b>Furniture, Boxes, Bags</b></td></tr><tr><td><b>Unit 3229 Jason Graham</b></td><td><b>Furniture, Boxes, Bags</b></td></tr></tbody></table> Purchases must be paid at the above referenced facility in order to complete the transaction. SmartStop Self Storage may refuse any bid and may rescind any purchase up until the winning bidder takes possession of the personal property. Please contact the property with any questions (941) 893-1782. June 26; July 3, 2026	<b>Unit 1180 Gary Sligar</b>	<b>Boxes, Totes, Clothes, Art, Golf Clubs</b>	<b>Unit 2230 Eileen Reed</b>	<b>Bags, Clothes</b>	<b>Unit 3209 Jasmine Locke</b>	<b>Furniture, Boxes, Bags</b>	<b>Unit 3229 Jason Graham</b>	<b>Furniture, Boxes, Bags</b>
<b>Unit 1180 Gary Sligar</b>	<b>Boxes, Totes, Clothes, Art, Golf Clubs</b>							
<b>Unit 2230 Eileen Reed</b>	<b>Bags, Clothes</b>							
<b>Unit 3209 Jasmine Locke</b>	<b>Furniture, Boxes, Bags</b>							
<b>Unit 3229 Jason Graham</b>	<b>Furniture, Boxes, Bags</b>							

FIRST INSERTION
<b>NOTICE OF RULE DEVELOPMENT BY THE LAKEWOOD RANCH STEWARDSHIP DISTRICT</b> In accordance with Chapter 120, Florida Statutes, and Chapter 2005-338, Laws of Florida, the Lakewood Ranch Stewardship District ("District") hereby gives notice of its intention to develop revised Rules of Procedure to govern the operations of the District. The proposed rule number is 2026-1.  The revised Rules of Procedure will address such areas as the Board of Supervisors, officers and voting, district offices, public information and inspection of records, policies, public meetings, hearings and workshops, rulemaking proceedings, competitive purchase including procedure under the Consultants' Competitive Negotiation Act, procedure regarding auditor selection, purchase of insurance, pre-qualification, construction contracts, goods, supplies and materials, maintenance services, contractual services and protests with respect to proceedings, as well as any other area of the general operation of the District.  The purpose and effect of the revised Rules of Procedure is to provide for efficient and effective District operations and to ensure compliance with recent changes to Florida law. The specific grant of rulemaking authority for the adoption of the revised Rules of Procedure includes Chapter 2005-338(6)(6)(e), (6)(6)(q) and (6)(20), Laws of Florida. The specific laws implemented in the revised Rules of Procedure include, but are not limited to, Sections 112.08, 112.3143, 112.31446, 112.3145, 119.07, 119.0701, 120.54, 120.542, 120.5435, 120.56, 120.69, 120.81, 189.053, 189.069, 218.33, 218.391, 255.05, 255.0518, 255.0525, 255.20, 286.0105, 286.011, 286.012, 286.0113, 286.0114, 287.017, 287.055, and 287.084, Florida Statutes, and Chapter 2005-338(5), (6)(1)-(4), (6)(6)(c), (6)(6)(e), (6)(6)(q), (6)(19), (6)(20), Laws of Florida.  A copy of the revised Rules of Procedure and the related incorporated documents, if any, may be obtained by contacting the District Manager, c/o PFM Management Services, LLC, 3501 Quadrangle Blvd., Suite 270, Orlando, Florida 32817, (407) 723-5900.  Jane Gaarlandt, District Manager Lakewood Ranch Stewardship District June 26, 2026

FIRST INSERTION
<b>THREE RIVERS STEWARDSHIP DISTRICT NOTICE OF REGULAR MEETING</b> Notice is hereby given that Board of Supervisors ("Board") of the Three Rivers Stewardship District ("District") will hold a Regular Meeting on July 8, 2026 at 11:30 a.m., at 5800 Lakewood Ranch Blvd. N, 1st floor Training Room, Sarasota, Florida 34240 to consider any and all business which may properly come before it.  The meeting is open to the public and will be conducted in accordance with the provision of Florida law. The meeting may be continued to a date, time, and place to be specified on the record at the meetings. A copy of the agenda for the meeting may be obtained by contacting the offices of the District Manager, Wrathell, Hunt & Associates, LLC, 2300 Glades Road, Suite 410W, Boca Raton, Florida 33431, (561) 571-0010, during normal business hours or by visiting the District's website, https://threeriverssd.net/.  There may be occasions when one or more Supervisors or staff will participate by telephone. Pursuant to provisions of the Americans with Disabilities Act, any person requiring special accommodations at the meeting because of a disability or physical impairment should contact the District Office at (561) 571-0010 at least 48 hours prior to the meeting. If you are hearing or speech impaired, please contact the Florida Relay Service by dialing 7-1-1, or 1-800-955-8771 (TTY) / 1-800-955-8770 (Voice), for aid in contacting the District Office.  A person who decides to appeal any decision made at the meeting with respect to any matter considered at the meeting is advised that person will need a record of the proceedings and that accordingly, the person may need to ensure that a verbatim record of the proceedings is made, including the testimony and evidence upon which such appeal is to be based.  District Manager June 26, 2026

FIRST INSERTION
<b>Notice of Auditor Selection Committee Meeting and Regular Board of Supervisors Meeting Lakewood Ranch Stewardship District</b> The Board of Supervisors of the Lakewood Ranch Stewardship District will hold its Regular Board Meeting and Auditor Selection Committee Meeting on Friday, July 10, 2026, at 9:00 a.m. at Schroeder-Manatee Ranch, Inc., 14400 Covenant Way, Lakewood Ranch, FL 34202. The regular meeting will take place immediately following the adjournment of the Auditor Committee meeting where the Board may consider any other business that may properly come before it. The Auditor Committee will review, discuss and rank the proposals received to perform the audit for the fiscal year ending September 30, 2026, as previously advertised in accordance with Florida law.  The meeting is open to the public and will be conducted in accordance with provisions of Florida Law for independent special districts. The meeting may be continued to a date, time, and place to be specified on the record at the meeting. There may be occasions when Supervisors or staff may participate by speaker telephone.  A copy of the agenda for the meeting may be obtained at the offices of the District Manager, PFM Group Consulting LLC., located at 3501 Quadrangle Boulevard, Suite 270, Orlando 32817, (407) 723-5900, during normal business hours.  Any person requiring special accommodations at the meeting because of disability or physical impairment should contact the District Office at (407) 723-5900 at least forty-eight (48) hours prior to the meeting. If you are hearing or speech impaired, please contact the Florida Relay Service at 1-800-955-8770, for aid in contacting the District Office.  Each person who decides to appeal any decision made by the Board with respect to any matter considered at the meeting is advised that person will need a record of the proceedings and that accordingly, the person may need to ensure that a verbatim record of the proceedings is made, including the testimony and evidence upon which such appeal is to be based.  Jane Gaarlandt District Manager June 26, 2026

FIRST INSERTION
<b>WINDWARD AT LAKEWOOD RANCH COMMUNITY DEVELOPMENT DISTRICT NOTICE OF MEETING</b> Notice is hereby given that the Board of Supervisors ("Board") of the Windward at Lakewood Ranch Community Development District ("District") will hold a regular meeting on July 8, 2026 at 11:30 a.m., or as soon thereafter as the matter may be heard, at 5800 Lakewood Ranch Blvd N, 1st Floor Training Room, Sarasota, FL 34240 to consider any and all business which may properly come before it.  The meeting is open to the public and will be conducted in accordance with the provisions of Florida law. The meeting may be continued to a date, time, and place to be specified on the record at such meeting. A copy of the agenda may be obtained at the offices of the District Manager, Wrathell, Hunt & Associates, LLC, 2300 Glades Road, Suite 410W, Boca Raton, Florida 33431, (561) 571-0010 ("District Manager's Office") during normal business hours or by visiting the District's website at http://windwardatlakewoodranchcdd.com/.  There may be occasions when Board Supervisors or District Staff may participate by speaker telephone. Pursuant to provisions of the Americans with Disabilities Act, any person requiring special accommodations at the meeting because of a disability or physical impairment should contact the District Manager's Office at least forty-eight (48) hours prior to the meeting. If you are hearing or speech impaired, please contact the Florida Relay Service by dialing 7-1-1, or 1-800-955-8771 (TTY) / 1-800-955-8770 (Voice), for aid in contacting the District Manager's Office.  Each person who decides to appeal any decision made by the Board with respect to any matter considered at the meeting is advised that person will need a record of proceedings and that accordingly, the person may need to ensure that a verbatim record of the proceedings is made, including the testimony and evidence upon which such appeal is to be based.  District Manager June 26, 2026

FIRST INSERTION
<b>NOTICE OF PUBLIC SALE</b> Notice is hereby given that on 07/10/2026, at 10:30 a.m., the following property will be sold at public auction pursuant to F.S. 715.109: A 1989 KROP mobile home bearing vehicle identification number 1K9HL30D3KG010151 and all personal items located inside the mobile home. Last Tenant: Kimberly Marie Becerra, Ramon Becerra, Kimberly Dawn Mandel and Justin Martin Sharbono. Sale to be held at: Palm Terrace, 3223 North Lockwood Ridge Road, Sarasota, Florida 34234, 941-529-7005. June 26; July 3, 2026

**PUBLISH YOUR LEGAL NOTICE**

**We publish all Public sale, Estate & Court-related notices**

- We offer an online payment portal for easy credit card payment
- Service includes us e-filing your affidavit to the Clerk's office on your behalf

Call **941-906-9386** and select the appropriate County name from the menu option or email **legal@businessobserverfl.com**

FLORIDA'S NEWSPAPER FOR THE G-SUITE  
**Business Observer**

## --- ESTATE ---

## FIRST INSERTION

**NOTICE TO CREDITORS**  
IN THE CIRCUIT COURT FOR  
SARASOTA COUNTY,  
FLORIDA PROBATE DIVISION  
File No. 2026 CP 0003052  
IN RE: ESTATE OF

**GLEN EDWARD YANCY, Deceased**  
The administration of the estate of Glen Edward Yancy, deceased, whose date of death was January 17, 2026, File Number 2026 CP 0003052, is pending in the Circuit Court for Sarasota County, Florida, Probate Division, the address of which is 2000 Main Street, Sarasota, Florida 34237. The names and addresses of the personal representative and the personal representative's attorney are set forth below.

All creditors of the decedent and other persons having claims or demands against decedent's estate on whom a copy of this notice is required to be served must file their claims with this Court WITHIN THE LATER OF 3 MONTHS AFTER THE DATE OF SERVICE OF THE FIRST PUBLICATION OF THIS NOTICE OR 30 DAYS AFTER THE TIME OF SERVICE OF A COPY OF THIS NOTICE ON THEM.

All other creditors of the decedent and other persons having claims or demands against decedent's estate must file their claims with this Court WITHIN 3 MONTHS AFTER THE DATE OF THE FIRST PUBLICATION OF THIS NOTICE.

ALL CLAIMS NOT SO FILED WILL BE FOREVER BARRED.  
NOTWITHSTANDING THE TIME PERIODS SET FORTH ABOVE, ANY CLAIM FILED TWO (2) YEARS OR MORE AFTER THE DECEDENT'S DATE OF DEATH IS BARRED.

The date of first publication of this notice is June 26, 2026.

**Personal Representative**  
**Nicole M. Stagnolia**

4825 West 1000 North  
Fountaintown, Indiana 46130  
Attorney for the  
Personal Representative  
Susan L. Adinamis  
Florida Bar No. 0050792  
Adinamis & Saunders, P.C.  
10401 N. Meridian Street, Suite 210  
Indianapolis, Indiana 46290  
317-218-2600  
June 26; July 3, 2026 26-014665

## FIRST INSERTION

**NOTICE TO CREDITORS**  
IN THE CIRCUIT COURT FOR  
SARASOTA COUNTY,  
FLORIDA PROBATE DIVISION  
File No. 2026 CP 2315 SC  
Division Probate  
IN RE: ESTATE OF

**Jeanine A. Rahl Deceased.**  
The administration of the estate of Jeanine A. Rahl, deceased, whose date of death was April 1st, 2026, is pending in the Circuit Court for Sarasota County, Florida, Probate Division, the address of which is PO BOX 3079, Sarasota, FL 34230. The names and addresses of the personal representative and the personal representative's attorney are set forth below.

All creditors of the decedent and other persons having claims or demands against decedent's estate on whom a copy of this notice is required to be served must file their claims with this court ON OR BEFORE THE LATER OF 3 MONTHS AFTER THE TIME OF THE FIRST PUBLICATION OF THIS NOTICE OR 30 DAYS AFTER THE DATE OF SERVICE OF A COPY OF THIS NOTICE ON THEM.

All other creditors of the decedent and other persons having claims or demands against decedent's estate must file their claims with this court WITHIN 3 MONTHS AFTER THE DATE OF THE FIRST PUBLICATION OF THIS NOTICE.

The personal representative has no duty to discover whether any property held at the time of the decedent's death

by the decedent or the decedent's surviving spouse is property to which the Florida Uniform Disposition of Community Property Rights at Death Act as described in ss. 732.216-732.228, applies, or may apply, unless a written demand is made by a creditor as specified under s. 732.221, Florida Statutes. The written demand must be filed with the clerk.

ALL CLAIMS NOT FILED WITHIN THE TIME PERIODS SET FORTH IN FLORIDA STATUTES SECTION 733.702 WILL BE FOREVER BARRED.

NOTWITHSTANDING THE TIME PERIODS SET FORTH ABOVE, ANY CLAIM FILED TWO (2) YEARS OR MORE AFTER THE DECEDENT'S DATE OF DEATH IS BARRED.

The date of first publication of this notice is June 26, 2026.

**Stacy L. Dening**  
**c/o Kanetsky, Moore & DeBoer, PA**

P.O. Address:  
227 Nokomis Avenue South  
Venice, FL 34285  
**Personal Representative**  
JON R. FAHS, Jr.  
KANETSKY, MOORE &  
DEBOER, P.A.  
ATTORNEYS AT LAW  
Attorneys for Personal Representative  
227 S. NOKOMIS AVE.  
VENICE, FL 34285  
Telephone: (941) 485-1571  
Florida Bar No. 1025389  
Email Addresses: jrf@kmdpa.com  
June 26; July 3, 2026 26-014675

## FIRST INSERTION

**NOTICE TO CREDITORS**  
IN THE CIRCUIT COURT FOR  
SARASOTA COUNTY,  
FLORIDA PROBATE DIVISION  
File No. 2026 CP 2832 SC  
Division South County  
IN RE: ESTATE OF

**PHILIP E. STANLEY**  
**Deceased.**

The administration of the estate of PHILIP E. STANLEY, deceased, whose date of death was April 20, 2026, is pending in the Circuit Court for SARASOTA County, Florida, Probate Division, the address of which is P.O. Box 3079, 2000 Main Street, Sarasota, FL 34237. The names and addresses of the personal representative and the personal representative's attorney are set forth below.

All creditors of the decedent and other persons having claims or demands against decedent's estate on whom a copy of this notice is required to be served must file their claims with this court ON OR BEFORE THE LATER OF 3 MONTHS AFTER THE TIME OF THE FIRST PUBLICATION OF THIS NOTICE OR 30 DAYS AFTER THE DATE OF SERVICE OF A COPY OF THIS NOTICE ON THEM.

All other creditors of the decedent and other persons having claims or demands against decedent's estate must file their claims with this court WITHIN 3 MONTHS AFTER THE DATE OF THE FIRST PUBLICATION OF THIS NOTICE.

The personal representative has no

duty to discover whether any property held at the time of the decedent's death by the decedent or the decedent's surviving spouse is property to which the Florida Uniform Disposition of Community Property Rights at Death Act as described in ss. 732.216-732.228, Florida Statutes, applies, or may apply, unless a written demand is made by a creditor as specified under s. 732.221, Florida Statutes. The written demand must be filed with the clerk.

ALL CLAIMS NOT FILED WITHIN THE TIME PERIODS SET FORTH IN FLORIDA STATUTES SECTION 733.702 WILL BE FOREVER BARRED.

NOTWITHSTANDING THE TIME PERIODS SET FORTH ABOVE, ANY CLAIM FILED TWO (2) YEARS OR MORE AFTER THE DECEDENT'S DATE OF DEATH IS BARRED.

The date of first publication of this notice is June 26, 2026.

**Personal Representative:**  
**LOIS J. STANLEY**

5078 Layton Dr  
Venice, Florida 34293  
Attorney for Personal Representative:  
STEPHEN K. BOONE  
Attorney  
Florida Bar Number: 0371068  
BOONE, BOONE & BOONE, P.A.  
1001 Avenida Del Circo  
VENICE, FL 34285  
Telephone: (941) 488-6716  
Fax: (941) 488-7079  
E-Mail: sboone@boone-law.com  
June 26; July 3, 2026 26-014375

## FIRST INSERTION

**NOTICE TO CREDITORS**  
IN THE CIRCUIT COURT FOR  
SARASOTA COUNTY,  
FLORIDA PROBATE DIVISION  
File No. 2026-CP-3300-NC  
Division Probate  
IN RE: ESTATE OF

**LAWRENCE HILDIN**  
**Deceased.**

The administration of the estate of Lawrence Hildin, deceased, whose date of death was May 26, 2026, is pending in the Circuit Court for Sarasota County, Florida, Probate Division, the address of which is P.O. Box 3079, Sarasota, Florida 34230. The names and addresses of the personal representative and the personal representative's attorney are set forth below.

All creditors of the decedent and other persons having claims or demands against decedent's estate on whom a copy of this notice is required to be served must file their claims with this court ON OR BEFORE THE LATER OF 3 MONTHS AFTER THE TIME OF THE FIRST PUBLICATION OF THIS NOTICE OR 30 DAYS AFTER THE DATE OF SERVICE OF A COPY OF THIS NOTICE ON THEM.

All other creditors of the decedent and other persons having claims or demands against decedent's estate must

file their claims with this court WITHIN 3 MONTHS AFTER THE DATE OF THE FIRST PUBLICATION OF THIS NOTICE.

ALL CLAIMS NOT FILED WITHIN THE TIME PERIODS SET FORTH IN FLORIDA STATUTES SECTION 733.702 WILL BE FOREVER BARRED.

NOTWITHSTANDING THE TIME PERIODS SET FORTH ABOVE, ANY CLAIM FILED TWO (2) YEARS OR MORE AFTER THE DECEDENT'S DATE OF DEATH IS BARRED.

The date of first publication of this notice is June 26, 2026.

**Personal Representative:**  
**Kathleen Hildin**

c/o BOYER & BOYER PA  
46 N Washington Blvd, Ste 21  
Sarasota, FL 34236  
Attorney for Personal Representative:  
Katherine M. Fall, Esq.  
Florida Bar Number: 1008504  
BOYER & BOYER PA  
46 N Washington Blvd, Ste 21  
Sarasota, FL 34236  
Telephone: (941) 365-2304  
Fax: (941) 364-9896  
Email: kate@boyerboyer.com  
Secondary Email:  
service@boyerboyer.com  
June 26; July 3, 2026 26-014595

## FIRST INSERTION

**NOTICE TO CREDITORS**  
IN THE CIRCUIT COURT FOR  
SARASOTA COUNTY, FLORIDA  
PROBATE DIVISION  
File No. 2026-CP-000615  
IN RE: ESTATE OF

**PAULINE NEWHOUSE,**  
**Deceased.**

The administration of the estate of PAULINE NEWHOUSE, deceased, whose date of death was December 28, 2025, is pending in the Circuit Court for Sarasota County, Florida, Probate Division, the address of which is 2000 Main St., Sarasota, FL 34237. The names and addresses of the personal representative and the personal representative's attorney are set forth below.

All creditors of the decedent and other persons having claims or demands against decedent's estate, on whom a copy of this notice is required to be served, must file their claims with this court ON OR BEFORE THE LATER OF 3 MONTHS AFTER THE TIME OF THE FIRST PUBLICATION OF THIS NOTICE OR 30 DAYS AFTER THE DATE OF SERVICE OF A COPY OF THIS NOTICE ON THEM.

All other creditors of the decedent and other persons having claims or demands against decedent's estate must file their claims with this court WITHIN 3 MONTHS AFTER THE DATE OF THE FIRST PUBLICATION OF THIS NOTICE.

The personal representative has no

duty to discover whether any property held at the time of the decedent's death by the decedent or the decedent's surviving spouse is property to which the Florida Uniform Disposition of Community Property Rights at Death Act as described in ss. 732.216-732.228, applies, or may apply, unless a written demand is made by a creditor as specified under s. 732.221, Florida Statutes.

ALL CLAIMS NOT FILED WITHIN THE TIME PERIODS SET FORTH IN FLORIDA STATUTES SECTION 733.702 WILL BE FOREVER BARRED.

NOTWITHSTANDING THE TIME PERIOD SET FORTH ABOVE, ANY CLAIM FILED TWO (2) YEARS OR MORE AFTER THE DECEDENT'S DATE OF DEATH IS BARRED.

The date of first publication of this notice is: June 26, 2026.

**RAYMOND SANDIFER**  
**Personal Representative**

3420 Desoto Road  
Sarasota, FL 34235  
Robert D. Hines, Esq.  
Attorney for Personal Representative  
Florida Bar No. 0413550  
Hines Norman Hines, P.L.  
1312 W. Fletcher Avenue, Suite B  
Tampa, FL 33612  
Telephone: 813-265-0100  
Email: rhines@hnh-law.com  
Secondary Email:  
nservice@hnh-law.com  
June 26; July 3, 2026 26-014545

## FIRST INSERTION

**NOTICE TO CREDITORS**  
IN THE CIRCUIT COURT FOR  
SARASOTA COUNTY,  
FLORIDA PROBATE DIVISION  
File No. 2026 CP 2322 NC  
Division Probate  
IN RE: ESTATE OF

**JOSIE M. MONTMINY**  
**Deceased.**

The administration of the estate of Josie M. Montminy, deceased, whose date of death was February 28, 2025, is pending in the Circuit Court for Sarasota County, Florida, Probate Division, the address of which is 2002 Ringling Blvd., Sarasota, FL 34237. The names and addresses of the personal representative and the personal representative's attorney are set forth below.

All creditors of the decedent and other persons having claims or demands against decedent's estate on whom a copy of this notice is required to be served must file their claims with this court ON OR BEFORE THE LATER OF 3 MONTHS AFTER THE TIME OF THE FIRST PUBLICATION OF THIS NOTICE OR 30 DAYS AFTER THE DATE OF SERVICE OF A COPY OF THIS NOTICE ON THEM.

All other creditors of the decedent and other persons having claims or demands against decedent's estate must file their claims with this court WITHIN 3 MONTHS AFTER THE DATE OF THE FIRST PUBLICATION OF THIS NOTICE.

The personal representative has no

held at the time of the decedent's death by the decedent or the decedent's surviving spouse is property to which the Florida Uniform Disposition of Community Property Rights at Death Act as described in ss. 732.216-732.228, Florida Statutes, applies, or may apply, unless a written demand is made by a creditor as specified under s. 732.221, Florida Statutes. The written demand must be filed with the clerk.

ALL CLAIMS NOT FILED WITHIN THE TIME PERIODS SET FORTH IN FLORIDA STATUTES SECTION 733.702 WILL BE FOREVER BARRED.

NOTWITHSTANDING THE TIME PERIODS SET FORTH ABOVE, ANY CLAIM FILED TWO (2) YEARS OR MORE AFTER THE DECEDENT'S DATE OF DEATH IS BARRED.

The date of first publication of this notice is June 26, 2026.

**Personal Representative:**  
**Bradford D. Gregory**

101 Oakland Ct  
Franklin, Kentucky 42134  
Attorney for Personal Representative:  
Christopher D. Smith, Esq.  
Attorney for Personal Representative  
Florida Bar Number: 0605433  
1561 Lakefront Dr Unit 204  
Sarasota, FL 34240  
Telephone: (941) 202-2222  
Fax: (941) 907-3040  
E-Mail: smith@chrissmith.com  
Secondary E-Mail:  
paralegals@chrissmith.com  
June 26; July 3, 2026 26-014305

## FIRST INSERTION

**NOTICE TO CREDITORS**  
IN THE CIRCUIT COURT FOR  
SARASOTA COUNTY,  
FLORIDA  
PROBATE DIVISION  
File Number: 2026-CP-002703-NC  
IN RE: ESTATE OF

**JULIUS FRANCIS BONELLO a/k/a JULIUS F. BONELLO a/k/a JULIUS BONELLO, deceased**

The ancillary administration of the estate of JULIUS FRANCIS BONELLO a/k/a JULIUS F. BONELLO a/k/a JULIUS BONELLO, deceased, whose date of death was November 21, 2024, is pending in the Circuit Court for SARASOTA County, Florida, Probate Division, the address of which is POST OFFICE BOX 3079, SARASOTA, FLORIDA 34230-3079. The names and addresses of the ancillary personal representative and the personal representative's attorney are set forth below.

All creditors of the decedent and other persons having claims or demands against decedent's estate on whom a copy of this notice is required to be served must file their claims with this court WITHIN THE LATER OF 3 MONTHS AFTER THE TIME OF THE FIRST PUBLICATION OF THIS NOTICE OR 30 DAYS AFTER THE DATE OF SERVICE OF A COPY OF THIS NOTICE ON THEM.

All other creditors of the decedent and other persons having claims or demands against decedent's estate must file their claims with this court WITHIN 3 MONTHS AFTER THE DATE OF THE FIRST PUBLICATION OF THIS NOTICE.

ALL CLAIMS NOT SO FILED WITHIN THE TIME PERIODS SET FORTH IN SECTION 733.702 OF THE FLORIDA PROBATE CODE WILL BE FOREVER BARRED.

NOTWITHSTANDING THE TIME PERIOD SET FORTH ABOVE, ANY CLAIM FILED TWO (2) YEARS OR MORE AFTER THE DECEDENT'S DATE OF DEATH IS BARRED.

The date of first publication of this notice is June 26, 2026

**Ancillary Personal Representative:**  
**Stephen Bonello**

4432 Gilford Dr  
Edina, MN 55410  
Attorney for  
Ancillary Personal Representative:  
J. Kevin Drake of  
J. Kevin Drake, P.A.  
Florida Bar No: 705055  
1432 First Street  
Sarasota, FL 34236  
(941) 954-7750  
kdrake@drakelawyers.com  
dussher@drakelawyers.com  
June 26; July 3, 2026 26-014685

## FIRST INSERTION

**NOTICE TO CREDITORS**  
IN THE CIRCUIT COURT FOR  
SARASOTA COUNTY,  
FLORIDA  
PROBATE DIVISION  
File No. 2026 CP 2689 NC  
Division Probate  
IN RE: ESTATE OF

**WILLIAM JACK LITTLER,**  
**Deceased.**

The administration of the estate of William Jack Littler, deceased, whose date of death was December 4, 2025, is pending in the Circuit Court for Sarasota County, Florida, Probate Division, the address of which is PO Box 3079, Sarasota, Florida 34230. The names and addresses of the personal representative and the personal representative's attorney are set forth below.

All creditors of the decedent and other persons having claims or demands against decedent's estate on whom a copy of this notice is required to be served must file their claims with this court ON OR BEFORE THE LATER OF 3 MONTHS AFTER THE TIME OF THE FIRST PUBLICATION OF THIS NOTICE OR 30 DAYS AFTER THE DATE OF SERVICE OF A COPY OF THIS NOTICE ON THEM.

All other creditors of the decedent and other persons having claims or demands against decedent's estate must file their claims with this court WITHIN 3 MONTHS AFTER THE DATE OF THE FIRST PUBLICATION OF THIS

NOTICE.

The personal representative has no duty to discover whether any property held at the time of the decedent's death by the decedent or the decedent's surviving spouse is property to which the Florida Uniform Disposition of Community Property Rights at Death Act as described in ss. 732.216-732.228, Florida Statutes, applies, or may apply, unless a written demand is made by a creditor as specified under s. 732.221, Florida Statutes. The written demand must be filed with the clerk.

ALL CLAIMS NOT FILED WITHIN THE TIME PERIODS SET FORTH IN FLORIDA STATUTES SECTION 733.702 WILL BE FOREVER BARRED.

NOTWITHSTANDING THE TIME PERIODS SET FORTH ABOVE, ANY CLAIM FILED TWO (2) YEARS OR MORE AFTER THE DECEDENT'S DATE OF DEATH IS BARRED.

The date of first publication of this notice is June 26, 2026.

Attorney for Personal Representative:  
T. Thomas Shirley  
Attorney & Personal Representative  
Florida Bar Number: 154581  
Dunkin & Shirley, P.A.  
170 West Dearborn Street  
Englewood, Florida 34223  
Telephone: (941) 474-7753  
Fax: (941) 475-1954  
E-Mail: tom@dunkinshirley.com  
June 26; July 3, 2026 26-014365

## FIRST INSERTION

**NOTICE TO CREDITORS**  
IN THE CIRCUIT COURT  
OF THE TWELFTH JUDICIAL  
CIRCUIT OF FLORIDA  
IN AND FOR  
SARASOTA COUNTY  
PROBATE DIVISION  
CASE NO: 2026 CP 003370 NC  
IN RE: ESTATE OF

**EMMA JEAN ROURKE,**  
**Deceased.**

The administration of the estate of EMMA JEAN ROURKE, deceased whose date of death was November 8, 2025, is pending in the Circuit Court for Sarasota County, Florida, Probate Division, the address of which is 2002 Ringling Blvd., Sarasota, Florida 34237. The name and address of the petitioner and the Petitioner's attorney are both set forth below.

All creditors of the decedent and other persons having claims or demands against decedent's estate, on whom a copy of this notice is required to be served must file their claims with this court ON OR BEFORE THE LATER OF 3 MONTHS AFTER THE TIME OF THE FIRST PUBLICATION OF THIS NOTICE, OR 30 DAYS AFTER THE DATE OF SERVICE OF A COPY OF THIS NOTICE ON THEM.

All other creditors of the decedent and other persons having claims or demands against decedent's estate must file their claims with this court WITHIN 3 MONTHS AFTER THE DATE OF THE FIRST PUBLICATION OF THIS NOTICE.

ALL CLAIMS NOT FILED WITHIN THE TIME PERIODS SET FORTH IN FLORIDA STATUTES SECTION 733.702 WILL BE FOREVER BARRED.

ADDITIONALLY, ANY CLAIM FILED TWO (2) YEARS OR MORE AFTER THE DECEDENT'S DATE OF DEATH IS BARRED. See Florida Statute Section 732.710; Tsuji v. Fleet, 366 So.3d 1020 (Fla. 2023).

The petitioner has no duty to discover whether any property held at the time of the decedent's death by the decedent or the decedent's surviving spouse is property to which the Florida Uniform Disposition of Community Property Rights at Death Act as described in sections 732.216-732.228, Florida Statutes, applies, or may apply, unless a written demand is made by a creditor as specified under section 732.221, Florida Statutes. The written demand must be filed with the clerk.

The date of first publication of this notice is June 26, 2026.

**Petitioner**  
**Sharon Collins**

180 Meadow Street  
East Haven, CT 06512  
Attorney for Petitioner  
Nick Rohnich, IV, Esq.  
Email: nicholas@nrpropertylaw.com  
Florida Bar No. 1028324  
THE ROKNICH LAW FIRM, P.A.  
1800 Second Street, Suite 854  
Sarasota, Florida 34236  
Phone: (941) 404-4540  
June 26; July 3, 2026 26-014355

# SAVE TIME



Email your Legal Notice  
[legal@businessobserverfl.com](mailto:legal@businessobserverfl.com)  
Deadline Wednesday at noon  
Friday Publication

SARASOTA • MANATEE • HILLSBOROUGH  
PASCO • PINELLAS • POLK • LEE  
COLLIER • CHARLOTTE

FLORIDA'S NEWSPAPER FOR THE C-SUITE  
**Business  
Observer**

--- ESTATE ---

FIRST INSERTION

**NOTICE TO CREDITORS**  
IN THE CIRCUIT COURT OF THE  
TWELFTH JUDICIAL CIRCUIT  
IN AND FOR SARASOTA COUNTY,  
FLORIDA PROBATE DIVISION  
**Case Number: 2026-CP-000990**  
IN RE: ESTATE OF  
**EDMUND WILLIAM ALBRIGHT,  
JR.**  
**Deceased.**

The administration of the Estate of EDMUND WILLIAM ALBRIGHT, JR., whose date of death was December 5, 2025, is pending in the Circuit Court for SARASOTA County, Florida, Probate Division, the address of which is 2000 Main Street, Sarasota, FL 34237. The names and address of the personal representative and personal representative's attorney are set forth below.

ALL INTERESTED PERSONS ARE NOTIFIED THAT:

All persons on whom this notice is served who have objections that challenge the validity of the will, the qualifications of the personal representative, venue, or jurisdiction of this Court are required to file their objections with this Court WITHIN THE LATER ON THREE MONTHS AFTER THE DATE OF THE FIRST PUBLICATION OF THIS NOTICE OR THIRTY DAYS AFTER THE DATE OF SERVICE OF A COPY OF THIS NOTICE ON THEM.

All creditors of the decedent and other persons having claims or demands

against the decedent's estate on whom a copy of this notice is served within three months after the date of the first publication of this notice must file their claims with this Court WITHIN THE LATER OF THREE MONTHS AFTER THE DATE OF THE FIRST PUBLICATION OF THIS NOTICE OR THREE MONTHS AFTER THE DATE OF SERVICE OF A COPY OF THIS NOTICE ON THEM.

All other creditors of the decedent and persons having claims or demands against the decedent's estate must file their claims with the Court WITHIN THREE MONTHS AFTER THE DATE OF THE FIRST PUBLICATION OF THIS NOTICE.

ALL CLAIMS DEMANDS AND OBJECTIONS NOT SO FILED WILL BE FOREVER BARRED.

The date of the first publication of this Notice is June 26, 2026.

**Persons giving Notice:**

**C. TED FRENCH,**

**Personal Representative**

c/o 2033 Main Street, Suite 404  
Sarasota, Florida 34237

C. Ted French, Esq.

Attorney for Personal Representative

Florida Bar No 173400

2033 Main Street, Suite 404

Sarasota, Florida 34237

(941) 955-0908 - phone

ted@tedfrench.org

June 26; July 3, 2026

26-01452S

FIRST INSERTION

**NOTICE TO CREDITORS**  
IN THE CIRCUIT COURT OF THE  
TWELFTH JUDICIAL CIRCUIT  
IN AND FOR SARASOTA COUNTY,  
FLORIDA  
PROBATE DIVISION  
**Case Number: 2026-CP-002411**  
IN RE: ESTATE OF  
**ANDREA BEER**  
**Deceased.**

The administration of the Estate of ANDREA BEER., whose date of death was April 9, 2026, is pending in the Circuit Court for SARASOTA County, Florida, Probate Division, the address of which is 2000 Main Street, Sarasota, FL 34237. The names and address of the personal representative and personal representative's attorney are set forth below.

ALL INTERESTED PERSONS ARE NOTIFIED THAT:

All persons on whom this notice is served who have objections that challenge the validity of the will, the qualifications of the personal representative, venue, or jurisdiction of this Court are required to file their objections with this Court WITHIN THE LATER ON THREE MONTHS AFTER THE DATE OF THE FIRST PUBLICATION OF THIS NOTICE OR THIRTY DAYS AFTER THE DATE OF SERVICE OF A COPY OF THIS NOTICE ON THEM.

All creditors of the decedent and other persons having claims or demands

against the decedent's estate on whom a copy of this notice is served within three months after the date of the first publication of this notice must file their claims with this Court WITHIN THE LATER OF THREE MONTHS AFTER THE DATE OF THE FIRST PUBLICATION OF THIS NOTICE OR THREE MONTHS AFTER THE DATE OF SERVICE OF A COPY OF THIS NOTICE ON THEM.

All other creditors of the decedent and persons having claims or demands against the decedent's estate must file their claims with the Court WITHIN THREE MONTHS AFTER THE DATE OF THE FIRST PUBLICATION OF THIS NOTICE.

ALL CLAIMS DEMANDS AND OBJECTIONS NOT SO FILED WILL BE FOREVER BARRED.

The date of the first publication of this Notice is June 26, 2026.

**Persons giving Notice:**

**ROBERT BEER,**

**Personal Representative**

c/o 2033 Main Street, Suite 404  
Sarasota, Florida 34237

C. Ted French, Esq.

Attorney for Personal Representative

Florida Bar No 173400

2033 Main Street, Suite 404

Sarasota, Florida 34237

(941) 955-0908 - phone

ted@tedfrench.org

June 26; July 3, 2026

26-01460S

FIRST INSERTION

**NOTICE TO CREDITORS**  
IN THE CIRCUIT COURT FOR  
SARASOTA COUNTY, FLORIDA  
PROBATE DIVISION  
**File No. 2026 CP 2543 NC**  
**Division: PROBATE**  
IN RE: ESTATE OF  
**DAPHNE CLAUDIA LEE, a/k/a**  
**D. CLAUDIA LEE, or**  
**CLAUDIA LEE, Deceased.**

The administration of the estate of DAPHNE CLAUDIA LEE, a/k/a D. CLAUDIA LEE, or CLAUDIA LEE, deceased, whose date of death was April 9th, 2026, is pending in the Circuit Court for Sarasota County, Florida, Probate Division, the address of which is P.O. Box 3079, Sarasota, Florida 34230-3079. The names and addresses of the personal representative and the personal representative's attorney are set forth below.

All creditors of the decedent and other persons having claims or demands against decedent's estate on whom a copy of this notice is required to be served must file their claims with this court ON OR BEFORE THE LATER OF 3 MONTHS AFTER THE TIME OF THE FIRST PUBLICATION OF THIS NOTICE OR 30 DAYS AFTER THE DATE OF SERVICE OF A COPY OF THIS NOTICE ON THEM.

All other creditors of the decedent and other persons having claims or demands against decedent's estate must file their claims with this court WITHIN 3 MONTHS AFTER THE DATE OF

THE FIRST PUBLICATION OF THIS NOTICE.

The personal representative has no duty to discover whether any property held at the time of the decedent's death by the decedent or the decedent's surviving spouse is property to which the Florida Uniform Disposition of Community Property Rights at Death Act as described in ss. 732.216-732.228, applies, or may apply, unless a written demand is made by a creditor as specified under s. 732.221, Florida Statutes. The written demand must be filed with the clerk.

ALL CLAIMS NOT FILED WITHIN THE TIME PERIODS SET FORTH IN FLORIDA STATUTES SECTION 733.702 WILL BE FOREVER BARRED.

NOTWITHSTANDING THE TIME PERIODS SET FORTH ABOVE, ANY CLAIM FILED TWO (2) YEARS OR MORE AFTER THE DECEDENT'S DATE OF DEATH IS BARRED.

**DWIGHT SULLIVAN,**

**Personal Representative#4**

421 Marlin Dr.

Venice, FL 34293

Kraig H. Koach

KOACH LAW FIRM, P.A.

2639 Fruitville Rd., Suite 302

Sarasota, FL 34237

Telephone: 941951-1234

Florida Bar No. 510830

Attorney for the

Personal Representative

June 26; July 3, 2026

26-01463S

FIRST INSERTION

**NOTICE TO CREDITORS**  
IN THE CIRCUIT COURT FOR  
SARASOTA COUNTY,  
FLORIDA  
PROBATE DIVISION  
**File No. 2026-CP-2248**  
IN RE: ESTATE OF  
**THOMAS SIMMS HOLDERNESS  
JR.,**  
**Deceased.**

The administration of the estate of THOMAS SIMMS HOLDERNESS JR., deceased, whose date of death was December 13, 2025, is pending in the Circuit Court for Sarasota County, Florida, Probate Division, the address of which is 2000 Main St., Sarasota, FL 34237. The names and addresses of the curator and the curator's attorney are set forth below.

All creditors of the decedent and other persons having claims or demands against decedent's estate, on whom a copy of this notice is required to be served, must file their claims with this court ON OR BEFORE THE LATER OF 3 MONTHS AFTER THE TIME OF THE FIRST PUBLICATION OF THIS NOTICE OR 30 DAYS AFTER THE DATE OF SERVICE OF A COPY OF THIS NOTICE ON THEM.

All other creditors of the decedent and other persons having claims or demands against decedent's estate must file their claims with this court WITHIN 3 MONTHS AFTER THE DATE OF THE FIRST PUBLICATION OF THIS NOTICE.

A Personal Representative or curator has no duty to discover whether any property held at the time of the decedent's death by the decedent or the decedent's surviving spouse is property to which the Florida Uniform Disposition of Community Property Rights at Death Act as described in ss. 732.216-732.228, applies, or may apply, unless a written demand is made by a creditor as specified under s. 732.221.

ALL CLAIMS NOT FILED WITHIN THE TIME PERIODS SET FORTH IN FLORIDA STATUTES SECTION 733.702 WILL BE FOREVER BARRED.

NOTWITHSTANDING THE TIME PERIOD SET FORTH ABOVE, ANY CLAIM FILED TWO (2) YEARS OR MORE AFTER THE DECEDENT'S DATE OF DEATH IS BARRED.

The date of first publication of this notice is: June 26, 2026.

**Robert D. Hines**

**Curator**

1312 W. Fletcher Avenue, Suite B  
Tampa, FL 33612

Robert D. Hines, Esq.

Attorney for Curator

Florida Bar No. 0413550

Hines Norman Hines, P.L.

1312 W. Fletcher Avenue, Suite B

Tampa, FL 33612

Telephone: 813-265-0100

Email: rhines@hnh-law.com

Secondary Email:

jriviera@hnh-law.com

June 26; July 3, 2026

26-01432S

FIRST INSERTION

**NOTICE TO CREDITORS**  
IN THE CIRCUIT COURT FOR  
SARASOTA COUNTY, FLORIDA  
PROBATE DIVISION  
**File No. 26-CP 696SC**  
**Division Probate**  
IN RE: ESTATE OF  
**WAYNESS BROWN HESLOP,**  
**Deceased.**

The administration of the estate of WAYNESS BROWN HESLOP, deceased, whose date of death was May 16, 2025, is pending in the Circuit Court for Sarasota County, Florida, Probate Division, the address of which is 2000 Main Street, Sarasota, FL 34237. The names and addresses of the personal representative and personal representative's attorney are set forth below.

All creditors of the decedent and other persons having claims or demands against decedent's estate on whom a copy of this notice is required to be served must file their claims with this court WITHIN THE LATER OF 3 MONTHS AFTER THE TIME OF THE FIRST PUBLICATION OF THIS NOTICE OR 30 DAYS AFTER THE DATE OF SERVICE OF A COPY OF THIS NOTICE ON THEM.

All other creditors of the decedent and other persons having claims or demands against decedent's estate must file their claims with this court WITHIN 3 MONTHS AFTER THE DATE OF THE FIRST PUBLICATION OF THIS NOTICE.

The personal representative has no

duty to discover whether any property held at the time of the decedent's death by the decedent or the decedent's surviving spouse is property to which the Florida Uniform Disposition of Community Property Rights at Death Act as described in ss. 732.216-732.228, Florida Statutes, applies, or may apply, unless a written demand is made by a creditor as specified under s. 732.221, Florida Statutes.

ALL CLAIMS NOT FILED WITHIN THE TIME PERIODS SET FORTH IN SECTION 733.702 OF THE FLORIDA PROBATE CODE WILL BE FOREVER BARRED.

NOTWITHSTANDING THE TIME PERIODS SET FORTH ABOVE, ANY CLAIM FILED TWO (2) YEARS OR MORE AFTER THE DECEDENT'S DATE OF DEATH IS BARRED.

The date of first publication of this notice is June 26, 2026.

**Personal Representative:**

**Brooke Stover**

70 Atwater Street  
Port Charlotte, FL 33954

Attorney for Personal Representative:

Pamela D. Keller, Esquire

Attorney for Personal Representative

Florida Bar Number: 082627

Keller Law Office, P.A.

201 W. Marion Avenue, Suite 1209

Punta Gorda, Florida 33950

Telephone: (941) 505-2555

Fax: (941) 505-2355

E-Mail: Administrator@kellerlaw.biz

June 26; July 3, 2026

26-01461S

FIRST INSERTION

**NOTICE TO CREDITORS**  
IN THE CIRCUIT COURT FOR  
THE 12TH JUDICIAL CIRCUIT IN  
AND FOR SARASOTA COUNTY,  
FLORIDA  
**File No. 2026-CP-002844-NC**  
**PROBATE DIVISION**  
IN RE: ESTATE OF  
**DENNIS RAY PARKE Deceased.**

The administration of the estate of DENNIS RAY PARKE, deceased, whose date of death was September 29, 2025, is pending in the Circuit Court for Sarasota County, Florida, Probate Division, the address of which is 2000 Main Street, Sarasota, FL 34237. The names and addresses of the personal representative and the personal representative's attorney are set forth below.

All creditors of the decedent and other persons having claims or demands against decedent's estate on whom a copy of this notice is required to be served must file their claims with this court ON OR BEFORE THE LATER OF 3 MONTHS AFTER THE TIME OF THE FIRST PUBLICATION OF THIS NOTICE OR 30 DAYS AFTER THE DATE OF SERVICE OF A COPY OF THIS NOTICE ON THEM.

All other creditors of the decedent and other persons having claims or demands against decedent's estate must file their claims with this court WITHIN 3 MONTHS AFTER THE DATE OF THE FIRST PUBLICATION OF THIS NOTICE.

The personal representative has no

duty to discover whether any property held at the time of the decedent's death by the decedent or the decedent's surviving spouse is property to which the Florida Uniform Disposition of Community Property Rights at Death Act as described in ss. 732.216-732.228, applies, or may apply, unless a written demand is made by a creditor as specified under s. 732.221, Florida Statutes. The written demand must be filed with the clerk.

ALL CLAIMS NOT FILED WITHIN THE TIME PERIODS SET FORTH IN FLORIDA STATUTES SECTION 733.702 WILL BE FOREVER BARRED.

NOTWITHSTANDING THE TIME PERIODS SET FORTH ABOVE, ANY CLAIM FILED TWO (2) YEARS OR MORE AFTER THE DECEDENT'S DATE OF DEATH IS BARRED.

The date of first publication of this notice is June 26, 2026.

**Personal Representative:**

**JEFFREY E. MILLER**

**c/o Timothy W. Gensmer, P.A.**

2831 Ringling Blvd, Suite 202-A

Sarasota, FL 34237

Attorney for Personal Representative:

TIMOTHY W. GENSMER, ESQ.

2831 Ringling Blvd, Suite 202-A

Sarasota, FL 34237

(941) 952-9377 Telephone

(941) 954-5605 Fax

tim@timgensmer.com Primary Email

FL Bar No. 586242

June 26; July 3, 2026

26-01462S

FIRST INSERTION

**NOTICE TO CREDITORS**  
IN THE CIRCUIT COURT FOR  
SARASOTA COUNTY,  
FLORIDA PROBATE DIVISION  
**File No. 2026 CP 2613 SC**  
**Division: PROBATE**  
IN RE: ESTATE OF  
**MICHAEL O. SIMMONS**  
**Deceased.**

The administration of the estate of MICHAEL O. SIMMONS, deceased, whose date of death was March 29, 2026, is pending in the Circuit Court for Sarasota County, Florida, Probate Division, the address of which is 4004 S. Tamiami Trail, Venice, FL 34293. The names and addresses of the personal representative and the personal representative's attorney are set forth below.

All creditors of the decedent and other persons having claims or demands against decedent's estate on whom a copy of this notice is required to be served must file their claims with this court ON OR BEFORE THE LATER OF 3 MONTHS AFTER THE TIME OF THE FIRST PUBLICATION OF THIS NOTICE OR 30 DAYS AFTER THE DATE OF SERVICE OF A COPY OF THIS NOTICE ON THEM.

All other creditors of the decedent and other persons having claims or demands against decedent's estate must file their claims with this court WITHIN 3 MONTHS AFTER THE DATE OF THE FIRST PUBLICATION OF THIS NOTICE.

The personal representative has no duty to discover whether any property

held at the time of the decedent's death by the decedent or the decedent's surviving spouse is property to which the Florida Uniform Disposition of Community Property Rights at Death Act as described in ss. 732.216-732.228, Florida Statutes, applies, or may apply, unless a written demand is made by a creditor as specified under s. 732.221, Florida Statutes. The written demand must be filed with the clerk.

ALL CLAIMS NOT FILED WITHIN THE TIME PERIODS SET FORTH IN FLORIDA STATUTES SECTION 733.702 WILL BE FOREVER BARRED.

NOTWITHSTANDING THE TIME PERIODS SET FORTH ABOVE, ANY CLAIM FILED TWO (2) YEARS OR MORE AFTER THE DECEDENT'S DATE OF DEATH IS BARRED.

The date of first publication of this notice is June 26, 2026.

**Personal Representative:**

**SHELLY KAY EDWARDS**

**c/o Staas Law Group, P.L.L.C.**

801 E. Venice Ave., Ste. 2

Venice, FL 34285

Attorney for Personal Representative:

JULIE A. COLLINS

Florida Bar Number: 0151483

Staas Law Group, P.L.L.C.

801 E. Venice Ave., Ste. 2

Venice, FL 34285

Telephone: (941) 408-8555

Fax: (941) 408-8556

E-Mail: jcollins@staaslawgroup.com

Secondary E-Mail:

e-service@veniceelderlaw.com

June 26; July 3, 2026

26-01431S

FIRST INSERTION

**NOTICE TO CREDITORS**  
IN THE CIRCUIT COURT FOR  
SARASOTA COUNTY,  
FLORIDA PROBATE DIVISION  
**File No. 2026 CP 002192**  
**Division: PROBATE**  
IN RE: ESTATE OF  
**BONNIE ANN BURKE, A/K/A**  
**BONNIE A. BURKE, A/K/A**  
**BONNIE BURKE, Deceased**

The administration of the estate of Bonnie Ann Burke, a/k/a Bonnie A. Burke, a/k/a Bonnie Burke, deceased, whose date of death was June 6, 2024, is pending in the Circuit Court for Sarasota County, Florida, Probate Division, the address of which is 2000 Main Street, Sarasota, FL 34237. The names and addresses of the personal representative and the personal representative's attorney are set forth below.

All creditors of the decedent and other persons having claims or demands against decedent's estate on whom a copy of this notice is required to be served must file their claims with this court ON OR BEFORE THE LATER OF 3 MONTHS AFTER THE TIME OF THE FIRST PUBLICATION OF THIS NOTICE OR 30 DAYS AFTER THE DATE OF SERVICE OF A COPY OF THIS NOTICE ON THEM.

All other creditors of the decedent and other persons having claims or demands against decedent's estate must file their claims with this court WITHIN 3 MONTHS AFTER THE DATE OF THE FIRST PUBLICATION OF THIS NOTICE.

The personal representative has no

duty to discover whether any property held at the time of the decedent's death by the decedent or the decedent's surviving spouse is property to which the Florida Uniform Disposition of Community Property Rights at Death Act as described in ss. 732.216-732.228, Florida Statutes, applies, or may apply, unless a written demand is made by a creditor as specified under s. 732.221, Florida Statutes. The written demand must be filed with the clerk.

ALL CLAIMS NOT FILED WITHIN THE TIME PERIODS SET FORTH IN FLORIDA STATUTES SECTION 733.702 WILL BE FOREVER BARRED.

NOTWITHSTANDING THE TIME PERIODS SET FORTH ABOVE, ANY CLAIM FILED TWO (2) YEARS OR MORE AFTER THE DECEDENT'S DATE OF DEATH IS BARRED.

The date of first publication of this notice is June 26, 2026.

**Personal Representative:**

**Elizabeth G. Lemire**

5 Brabook Road Alton, MA 01720

Cheyenne R. Young

Attorney for Personal Representative

Florida Bar Number: 0515299

WOTITZKY,

## --- ESTATE ---

## FIRST INSERTION

**NOTICE TO CREDITORS**  
IN THE CIRCUIT COURT OF THE  
TWELFTH JUDICIAL CIRCUIT  
IN AND FOR SARASOTA COUNTY,  
FLORIDA PROBATE DIVISION  
**File No. 2026-CP-1731-NC**  
**IN RE: ESTATE OF**  
**CYNTHIA L. OLSEN,**  
(F/K/A CYNTHIA S. BROUWER),  
(F/K/A CYNTHIA S. OLSEN),  
Deceased.

The administration of the estate of CYNTHIA L. OLSEN (f/k/a CYNTHIA S. BROUWER; F/K/A CYNTHIA S. OLSEN), deceased, whose date of death was March 23, 2025, is pending in the Circuit Court for Sarasota County, Florida, Probate Division, the address of which is Post Office Box 3079, Sarasota, FL 34230. The names and addresses of the personal representative and the personal representative's attorney are set forth below.

All creditors of the decedent and other persons having claims or demands against decedent's estate on whom a copy of this notice is required to be served must file their claims with this court ON OR BEFORE THE LATER OF 3 MONTHS AFTER THE TIME OF THE FIRST PUBLICATION OF THIS NOTICE OR 30 DAYS AFTER THE DATE OF SERVICE OF A COPY OF THIS NOTICE ON THEM.

All other creditors of the decedent and other persons having claims or demands against decedent's estate must file their claims with this court WITHIN 3 MONTHS AFTER THE DATE OF

THE FIRST PUBLICATION OF THIS NOTICE.

The personal representative has no duty to discover whether any property held at the time of the decedent's death by the decedent or the decedent's surviving spouse is property to which the Florida Uniform Disposition of Community Property Rights at Death Act as described in ss. 732.216-732.228, applies, or may apply, unless a written demand is made by a creditor as specified under s. 732.2211, Florida Statutes.

ALL CLAIMS NOT FILED WITHIN THE TIME PERIODS SET FORTH IN FLORIDA STATUTES SECTION 733.702 WILL BE FOREVER BARRED.

NOTWITHSTANDING THE TIME PERIOD SET FORTH ABOVE, ANY CLAIM FILED TWO (2) YEARS OR MORE AFTER THE DECEDENT'S DATE OF DEATH IS BARRED.

The date of first publication of this notice is June 26, 2026.

**Personal Representative:**  
**Robert A. Stranahan, IV**  
4A Rancho Este  
Santa Fe, NM, 87506

Attorney for Personal Representative:  
Luke X. Johnston, Esquire  
Florida Bar No. 1037682  
LEE & EVANS, P.A.  
2601 Cattlemen Road, Suite 503  
Sarasota, Florida 34232  
Telephone: (941) 954-0067  
Facsimile: (941) 365-1492  
Email: ljohnston@leeandevans.com  
June 26; July 3, 2026 26-014555

## FIRST INSERTION

**NOTICE TO CREDITORS**  
IN THE CIRCUIT COURT FOR  
SARASOTA COUNTY, FLORIDA  
PROBATE DIVISION  
**File No. 2026 CP 002505 NC**  
**IN RE: ESTATE OF**  
**CHRISTINE NICKSON, Deceased.**

The administration of the estate of CHRISTINE NICKSON, deceased, whose date of death was October 7, 2025, is pending in the Circuit Court for Sarasota County, Florida, Probate Division, the address of which is P.O. Box 3079, Sarasota, FL 34230. The names and addresses of the personal representative and the personal representative's attorney are set forth below.

All creditors of the decedent and other persons having claims or demands against decedent's estate on whom a copy of this notice is required to be served must file their claims with this court ON OR BEFORE THE LATER OF 3 MONTHS AFTER THE TIME OF THE FIRST PUBLICATION OF THIS NOTICE OR 30 DAYS AFTER THE DATE OF SERVICE OF A COPY OF THIS NOTICE ON THEM.

All other creditors of the decedent and other persons having claims or demands against decedent's estate must file their claims with this court WITHIN 3 MONTHS AFTER THE DATE OF THE FIRST PUBLICATION OF THIS NOTICE.

The personal representative has no duty to discover whether any property held at the time of the decedent's death by the decedent or the decedent's sur-

viving spouse is property to which the Florida Uniform Disposition of Community Property Rights at Death Act as described in ss. 732.216-732.228, applies, or may apply, unless a written demand is made by a creditor as specified under s. 732.2211, Florida Statutes. The written demand must be filed with the clerk.

ALL CLAIMS NOT FILED WITHIN THE TIME PERIODS SET FORTH IN FLORIDA STATUTES SECTION 733.702 WILL BE FOREVER BARRED.

NOTWITHSTANDING THE TIME PERIOD SET FORTH ABOVE, ANY CLAIM FILED TWO (2) YEARS OR MORE AFTER THE DECEDENT'S DATE OF DEATH IS BARRED.

The date of first publication of this notice is June 26, 2026.

**Personal Representative:**  
**GEORGE NICKSON**  
1541 Cedar Hill Ave.  
Dallas, TX 75208

Attorney for Personal Representative:  
LORENZO A. FERNANDEZ  
Florida Bar No. 1039984  
Williams Parker Harrison Dietz & Getzen  
50 Central Avenue, Eighth Floor  
Sarasota, FL 34236  
Telephone: 941-366-4800  
Designation of Email Addresses for service: Primary:  
lfernandez@williamsparker.com  
Secondary:  
pkehoe@williamsparker.com  
June 26; July 3, 2026 26-014535

## FIRST INSERTION

**NOTICE TO CREDITORS**  
IN THE CIRCUIT COURT FOR  
SARASOTA COUNTY,  
FLORIDA  
PROBATE DIVISION  
**File No. 2026-CP-002477-NC**  
**Division Probate**  
**IN RE: ESTATE OF**  
**HARRY RONALD**  
**NORTHINGTON, Deceased.**

The administration of the estate of Harry Ronald Northington, deceased, whose date of death was January 6, 2026, is pending in the Circuit Court for Sarasota County, Florida, Probate Division, the address of which is P.O. Box 3079, Sarasota, FL 34230. The names and addresses of the personal representative and the personal representative's attorney are set forth below.

All creditors of the decedent and other persons having claims or demands against decedent's estate on whom a copy of this notice is required to be served must file their claims with this court ON OR BEFORE THE LATER OF 3 MONTHS AFTER THE TIME OF THE FIRST PUBLICATION OF THIS NOTICE OR 30 DAYS AFTER THE DATE OF SERVICE OF A COPY OF THIS NOTICE ON THEM.

All other creditors of the decedent and other persons having claims or demands against decedent's estate must file their claims with this court WITHIN 3 MONTHS AFTER THE DATE OF THE FIRST PUBLICATION OF THIS NOTICE.

The personal representative has no duty to discover whether any property

held at the time of the decedent's death by the decedent or the decedent's surviving spouse is property to which the Florida Uniform Disposition of Community Property Rights at Death Act as described in ss. 732.216-732.228, applies, or may apply, unless a written demand is made by a creditor as specified under s. 732.2211, Florida Statutes. The written demand must be filed with the clerk.

ALL CLAIMS NOT FILED WITHIN THE TIME PERIODS SET FORTH IN FLORIDA STATUTES SECTION 733.702 WILL BE FOREVER BARRED.

NOTWITHSTANDING THE TIME PERIOD SET FORTH ABOVE, ANY CLAIM FILED TWO (2) YEARS OR MORE AFTER THE DECEDENT'S DATE OF DEATH IS BARRED.

The date of first publication of this notice is June 26, 2026.

**Regions Bank**  
**Personal Representative:**  
**By: Marilyn E. Rozier,**  
**Senior Vice President**  
6200 Popular Avenue  
Memphis, TN 38119

Attorney for Personal Representative:  
Charla M. Burchett  
E-Mail Addresses:  
cburchett@shutts.com  
cmbcour@shutts.com  
Florida Bar No. 0813230  
Shutts & Bowen LLP  
1858 Ringling Blvd., Suite 300  
Sarasota, FL 34236  
Telephone: (941) 552-3500  
June 26; July 3, 2026 26-014565

## FIRST INSERTION

**NOTICE TO CREDITORS**  
IN THE CIRCUIT COURT FOR  
SARASOTA COUNTY, FLORIDA  
PROBATE DIVISION  
**File No. 2026 CP 003267 NC**  
**IN RE: ESTATE OF**  
**MELISSA L ROSATI**  
**Deceased.**

The administration of the estate of MELISSA L ROSATI, deceased, whose date of death was November 8, 2025, is pending in the Circuit Court for SARASOTA County, Florida, Probate Division, the address of which is Physical Address 2002 Ringling Blvd., Sarasota, FL 34237 and Mailing Address P.O. Box 48927, Sarasota, FL 34230. The names and addresses of the personal representative and the personal representative's attorney are set forth below.

All creditors of the decedent and other persons having claims or demands against decedent's estate on whom a copy of this notice is required to be served must file their claims with this court ON OR BEFORE THE LATER OF 3 MONTHS AFTER THE TIME OF THE FIRST PUBLICATION OF THIS NOTICE OR 30 DAYS AFTER THE DATE OF SERVICE OF A COPY OF THIS NOTICE ON THEM.

All other creditors of the decedent and other persons having claims or demands against decedent's estate must file their claims with this court WITHIN 3 MONTHS AFTER THE DATE OF THE FIRST PUBLICATION OF THIS NOTICE.

The personal representative has no

duty to discover whether any property held at the time of the decedent's death by the decedent or the decedent's surviving spouse is property to which the Florida Uniform Disposition of Community Property Rights at Death Act as described in ss. 732.216-732.228, Florida Statutes, applies, or may apply, unless a written demand is made by a creditor as specified under s. 732.2211, Florida Statutes. The written demand must be filed with the clerk.

ALL CLAIMS NOT FILED WITHIN THE TIME PERIODS SET FORTH IN FLORIDA STATUTES SECTION 733.702 WILL BE FOREVER BARRED.

NOTWITHSTANDING THE TIME PERIODS SET FORTH ABOVE, ANY CLAIM FILED TWO (2) YEARS OR MORE AFTER THE DECEDENT'S DATE OF DEATH IS BARRED.

The date of first publication of this notice is June 26, 2026.

**Personal Representative:**  
**ALBERT ROSATI**  
1614 ANCHORAGE ST  
SARASOTA, Florida 34231-3702

Attorney for Personal Representative:  
FRANCIS M. LEE, Attorney  
Florida Bar Number: 0642215  
4551 MAINLANDS BLVD W, STE F  
PINELLAS PARK, FL 33782  
Telephone: (727) 576-1203  
Fax: (727) 576-2161  
E-Mail: patricia@franklelaw.com  
Secondary E-Mail:  
frank@franklelaw.com  
June 26; July 3, 2026 26-014645

## FIRST INSERTION

**NOTICE TO CREDITORS**  
IN THE CIRCUIT COURT FOR  
SARASOTA COUNTY,  
FLORIDA  
PROBATE DIVISION  
**File No. 2026 CP 3030 NC**  
**Division Probate**  
**IN RE: ESTATE OF**  
**SARA MCCORKLE**  
**Deceased.**

The administration of the estate of Sara McCorkle, deceased, whose date of death was September 22, 2025, is pending in the Circuit Court for Sarasota County, Florida, Probate Division, the address of which is 2000 Main Street, Sarasota, FL 34231. The names and addresses of the personal representative and the personal representative's attorney are set forth below.

All creditors of the decedent and other persons having claims or demands against decedent's estate on whom a copy of this notice is required to be served must file their claims with this court ON OR BEFORE THE LATER OF 3 MONTHS AFTER THE TIME OF THE FIRST PUBLICATION OF THIS NOTICE OR 30 DAYS AFTER THE DATE OF SERVICE OF A COPY OF THIS NOTICE ON THEM.

All other creditors of the decedent and other persons having claims or demands against decedent's estate must file their claims with this court WITHIN 3 MONTHS AFTER THE DATE OF THE FIRST PUBLICATION OF THIS NOTICE.

The personal representative has no duty to discover whether any property

held at the time of the decedent's death by the decedent or the decedent's surviving spouse is property to which the Florida Uniform Disposition of Community Property Rights at Death Act as described in ss. 732.216-732.228, Florida Statutes, applies, or may apply, unless a written demand is made by a creditor as specified under s. 732.2211, Florida Statutes. The written demand must be filed with the clerk.

ALL CLAIMS NOT FILED WITHIN THE TIME PERIODS SET FORTH IN FLORIDA STATUTES SECTION 733.702 WILL BE FOREVER BARRED.

NOTWITHSTANDING THE TIME PERIODS SET FORTH ABOVE, ANY CLAIM FILED TWO (2) YEARS OR MORE AFTER THE DECEDENT'S DATE OF DEATH IS BARRED.

The date of first publication of this notice is June 26, 2026.

**Personal Representative:**  
**Beverly Morrison**  
941 Tamiami Trail South  
Sarasota, Florida 34285

Attorney for Personal Representative:  
John T. Griffin  
Attorney  
Florida Bar Number: 0674281  
GRIFFIN & GRIFFIN  
7077 S. Tamiami Trail  
Sarasota, FL 34231  
Telephone: (941) 966-2700  
Fax: (941) 966-2722  
E-Mail: john@griffinelaw.com  
Secondary E-Mail:  
tish@griffinelaw.com  
June 26; July 3, 2026 26-014605

## FIRST INSERTION

**NOTICE TO CREDITORS**  
IN THE CIRCUIT COURT FOR  
SARASOTA COUNTY,  
FLORIDA  
PROBATE DIVISION  
**File No. 2026-CP-003376-NC**  
**Division Probate**  
**IN RE: ESTATE OF**  
**RONALD EDWARD BOREK**  
**Deceased.**

The administration of the estate of RONALD EDWARD BOREK, deceased, whose date of death was May 22, 2026, is pending in the Circuit Court for Sarasota County, Florida, Probate Division, the address of which is 2002 Ringling Blvd, Sarasota, FL 34237. The names and addresses of the personal representative and the personal representative's attorney are set forth below.

All creditors of the decedent and other persons having claims or demands against decedent's estate on whom a copy of this notice is required to be served must file their claims with this court ON OR BEFORE THE LATER OF 3 MONTHS AFTER THE TIME OF THE FIRST PUBLICATION OF THIS NOTICE OR 30 DAYS AFTER THE DATE OF SERVICE OF A COPY OF THIS NOTICE ON THEM.

All other creditors of the decedent and other persons having claims or demands against decedent's estate must file their claims with this court WITHIN 3 MONTHS AFTER THE DATE OF THE FIRST PUBLICATION OF THIS NOTICE.

The personal representative has no duty to discover whether any property

held at the time of the decedent's death by the decedent or the decedent's surviving spouse is property to which the Florida Uniform Disposition of Community Property Rights at Death Act as described in ss. 732.216-732.228, Florida Statutes, applies, or may apply, unless a written demand is made by a creditor as specified under s. 732.2211, Florida Statutes. The written demand must be filed with the clerk.

ALL CLAIMS NOT FILED WITHIN THE TIME PERIODS SET FORTH IN FLORIDA STATUTES SECTION 733.702 WILL BE FOREVER BARRED.

NOTWITHSTANDING THE TIME PERIODS SET FORTH ABOVE, ANY CLAIM FILED TWO (2) YEARS OR MORE AFTER THE DECEDENT'S DATE OF DEATH IS BARRED.

The date of first publication of this notice is June 26, 2026.

**Personal Representative:**  
**Judith Lynn VanCoeveering**  
6721 Carlyle Lane  
Sarasota, Florida 34243

Attorney for Personal Representative:  
Emily M. Flinchpaugh, Esquire  
Attorney for Personal Representative  
Florida Bar Number: 1058216  
Berlin Patten Ebling PLLC  
3700 S Tamiami Trail #200  
Sarasota, Florida 34239  
Telephone: (941) 954-9991  
Fax: (941) 954-9992  
E-Mail:  
eflinchpaugh@berlinpatten.com  
Secondary E-Mail:  
slindsay@berlinpatten.com  
June 26; July 3, 2026 26-014655

## FIRST INSERTION

**NOTICE TO CREDITORS**  
IN THE CIRCUIT COURT FOR  
SARASOTA COUNTY,  
FLORIDA PROBATE DIVISION  
**File No. 2026CP003175SC**  
**Division Probate**  
**IN RE: ESTATE OF**  
**MILJKA MAKSIĆ**  
**Deceased.**

The administration of the estate of Miljka Maksic, deceased, whose date of death was January 26, 2025, is pending in the Circuit Court for Sarasota County, Florida, Probate Division, the address of which is PO Box 3079, Sarasota, FL 34230. The names and addresses of the personal representative and the personal representative's attorney are set forth below.

All creditors of the decedent and other persons having claims or demands against decedent's estate on whom a copy of this notice is required to be served must file their claims with this court ON OR BEFORE THE LATER OF 3 MONTHS AFTER THE TIME OF THE FIRST PUBLICATION OF THIS NOTICE OR 30 DAYS AFTER THE DATE OF SERVICE OF A COPY OF THIS NOTICE ON THEM.

All other creditors of the decedent and other persons having claims or demands against decedent's estate must file their claims with this court WITHIN 3 MONTHS AFTER THE DATE OF THE FIRST PUBLICATION OF THIS NOTICE.

The personal representative has no duty to discover whether any property

held at the time of the decedent's death by the decedent or the decedent's surviving spouse is property to which the Florida Uniform Disposition of Community Property Rights at Death Act as described in ss. 732.216-732.228, Florida Statutes, applies, or may apply, unless a written demand is made by a creditor as specified under s. 732.2211, Florida Statutes. The written demand must be filed with the clerk.

ALL CLAIMS NOT FILED WITHIN THE TIME PERIODS SET FORTH IN FLORIDA STATUTES SECTION 733.702 WILL BE FOREVER BARRED.

NOTWITHSTANDING THE TIME PERIODS SET FORTH ABOVE, ANY CLAIM FILED TWO (2) YEARS OR MORE AFTER THE DECEDENT'S DATE OF DEATH IS BARRED.

The date of first publication of this notice is June 26, 2026.

**Personal Representative:**  
**Sladjana Joncic**  
1139 Comfort Lane  
North Port, Florida 34288

Attorney for Personal Representative:  
Jeffrey M. Backo  
Attorney  
Florida Bar Number: 0086426  
MELLOR & BACKO LLP  
13801 Tamiami Trail, Suite D  
North Port, Florida 34287  
Telephone: (941) 426-1193  
Fax: (941) 426-5413  
E-Mail: jeff@northportlaw.com  
Secondary: shelly@northportlaw.com  
June 26; July 3, 2026 26-014715

## FIRST INSERTION

**NOTICE TO CREDITORS**  
IN THE CIRCUIT COURT FOR  
SARASOTA COUNTY,  
FLORIDA  
PROBATE DIVISION  
**File No. 2026 CP 002930 NC**  
**IN RE: ESTATE OF**  
**CLARA JEANETTE HAASE,**  
**Deceased.**

The administration of the estate of CLARA JEANETTE HAASE, deceased, whose date of death was January 7, 2026, is pending in the Circuit Court for Sarasota County, Florida, Probate Division, the address of which is P.O. Box 3079, Sarasota, FL 34230. The names and addresses of the personal representative and the personal representative's attorney are set forth below.

All creditors of the decedent and other persons having claims or demands against decedent's estate on whom a copy of this notice is required to be served must file their claims with this court ON OR BEFORE THE LATER OF 3 MONTHS AFTER THE TIME OF THE FIRST PUBLICATION OF THIS NOTICE OR 30 DAYS AFTER THE DATE OF SERVICE OF A COPY OF THIS NOTICE ON THEM.

All other creditors of the decedent and other persons having claims or demands against decedent's estate must file their claims with this court WITHIN 3 MONTHS AFTER THE DATE OF THE FIRST PUBLICATION OF THIS NOTICE.

The personal representative has no duty to discover whether any property held at the time of the decedent's death

by the decedent or the decedent's surviving spouse is property to which the Florida Uniform Disposition of Community Property Rights at Death Act as described in ss. 732.216-732.228, applies, or may apply, unless a written demand is made by a creditor as specified under s. 732.2211, Florida Statutes. The written demand must be filed with the clerk.

ALL CLAIMS NOT FILED WITHIN THE TIME PERIODS SET FORTH IN FLORIDA STATUTES SECTION 733.702 WILL BE FOREVER BARRED.

NOTWITHSTANDING THE TIME PERIOD SET FORTH ABOVE, ANY CLAIM FILED TWO (2) YEARS OR MORE AFTER THE DECEDENT'S DATE OF DEATH IS BARRED.

The date of first publication of this notice is June 26, 2026.

**Personal Representative:**  
**TENA I. WILSON**  
15710 Turiya Creek Way  
Sarasota, FL 34240

Attorney for Personal Representative:  
FLETCHER H. RUSH  
Florida Bar No. 0100586  
Williams Parker Harrison Dietz & Getzen 50 Central Avenue,  
Eighth Floor  
Sarasota, FL 34236  
Telephone: 941-552-2563  
Designation of Email  
Addresses for service:  
Primary: frush@williamsparker.com  
Secondary:  
pkehoe@williamsparker.com  
June 26; July 3, 2026 26-014585

## FIRST INSERTION

**NOTICE TO CREDITORS**  
**(Summary Administration)**  
IN THE CIRCUIT COURT FOR  
SARASOTA COUNTY,  
FLORIDA  
PROBATE DIVISION  
**File No. 2026 CP 003140 NC**  
**Division: Probate**  
**IN RE: ESTATE OF**  
**ROSEMARY ZIEFEL (AKA**  
**ROSEMARY T. ZIEFEL), Deceased.**  
TO ALL PERSONS HAVING CLAIMS  
OR DEMANDS AGAINST THE  
ABOVE ESTATE:

You are hereby notified that an Order of Summary Administration has been entered in the estate of Rosemary Ziefel (aka Rosemary T. Ziefel), deceased, File Number 2026 CP 003140 NC, by the Circuit Court for Sarasota County, Florida, Probate Division, the address of which is 2000 Main Street, Sarasota, FL 34237; that the decedent's date of death was November 21, 2025; that the total value of the estate is \$6,300.00 and that the names and addresses of those to whom it has been assigned by such order are:

Name Address  
Herbert P. Ziefel, Jr.  
4893 Orange Tree Place,  
Venice, FL 34293

ALL INTERESTED PERSONS ARE NOTIFIED THAT:

All creditors of the estate of the decedent and persons having claims or demands against the estate of the decedent other than those for whom provision for full payment was made in the Order of Summary Administration must file their claims with this court WITHIN THE TIME PERIODS SET FORTH IN FLORIDA STATUTES SECTION 733.702. ALL CLAIMS AND

DEMANDS NOT SO FILED WILL BE FOREVER BARRED. NOTWITHSTANDING ANY OTHER APPLICABLE TIME PERIOD, ANY CLAIM FILED TWO (2) YEARS OR MORE AFTER THE DECEDENT'S DATE OF DEATH IS BARRED.

The personal representative has no duty to discover whether any property held at the time of the decedent's death by the decedent or the decedent's surviving spouse is property to which the Florida Uniform Disposition of Community Property Rights at Death Act as described in sections 732.216-732.228 Florida Statutes, applies, or may apply, unless a written demand is made by a creditor as specified under section 732.2211, Florida Statutes. The written demand must be filed with the clerk.

The date of first publication of this Notice is June 26, 2026.

**Personal Giving Notice:**  
**Herbert P. Ziefel, Jr.**

c/o Ledbetter Cowan Law Group  
229 Pensacola Road Venice, FL 34285  
Attorney for Personal Giving Notice  
Ledbetter Cowan Law Group  
Steven W. Ledbetter, Esq.,  
FL Bar No. 41345  
Email: steve@ledbettercowan.com  
Callie W. Cowan, Esq.,  
FL Bar No. 57893  
Email: callie@ledbettercowan.com  
Jada W. Terreros, Esq.,  
FL Bar No. 1032584  
Email: jada@ledbettercowan.com  
229 Pensacola Road,  
Venice, Florida 34285  
Tel: (941) 256-3965  
Fax: (941) 866-7514  
2nd Email:  
probate@ledbettercowan.com  
June 26; July 3, 2026 26-014575

SUBSCRIBE TO THE BUSINESS OBSERVER

Call: (941) 362-4848 or go to: [www.businessobserverfl.com](http://www.businessobserverfl.com)

Business  
Observer

--- ESTATE ---

FIRST INSERTION

**NOTICE TO CREDITORS**  
IN THE CIRCUIT COURT FOR  
SARASOTA COUNTY,  
FLORIDA PROBATE DIVISION  
**File No. 2026 CP 2861 NC**  
**Division Probate**  
**IN RE: ESTATE OF**  
**OSCAR R. BELLE**  
**Deceased.**

The administration of the estate of OSCAR R. BELLE, deceased, whose date of death was April 27, 2026, is pending in the Circuit Court for SARASOTA County, Florida, Probate Division, the address of which is P.O. Box 3079, Sarasota, FL 34230-3079. The names and addresses of the personal representative and the personal representative's attorney are set forth below.

All creditors of the decedent and other persons having claims or demands against decedent's estate on whom a copy of this notice is required to be served must file their claims with this court ON OR BEFORE THE LATER OF 3 MONTHS AFTER THE TIME OF THE FIRST PUBLICATION OF THIS NOTICE OR 30 DAYS AFTER THE DATE OF SERVICE OF A COPY OF THIS NOTICE ON THEM.

All other creditors of the decedent and other persons having claims or demands against decedent's estate must file their claims with this court WITHIN 3 MONTHS AFTER THE DATE OF THE FIRST PUBLICATION OF THIS NOTICE.

The personal representative has no duty to discover whether any property

held at the time of the decedent's death by the decedent or the decedent's surviving spouse is property to which the Florida Uniform Disposition of Community Property Rights at Death Act as described in ss. 732.216-732.228, Florida Statutes, applies, or may apply, unless a written demand is made by a creditor as specified under s. 732.2211, Florida Statutes. The written demand must be filed with the clerk.

ALL CLAIMS NOT FILED WITHIN THE TIME PERIODS SET FORTH IN FLORIDA STATUTES SECTION 733.702 WILL BE FOREVER BARRED.

NOTWITHSTANDING THE TIME PERIODS SET FORTH ABOVE, ANY CLAIM FILED TWO (2) YEARS OR MORE AFTER THE DECEDENT'S DATE OF DEATH IS BARRED.

The date of first publication of this notice is June 26, 2026.

**Personal Representative:**

**MICHAEL J. BELLE**  
5129 Willow Links  
Sarasota, Florida 34235  
Attorney for Personal Representative:  
DOROTHY L. KORSZEN, ESQUIRE  
Florida Bar Number: 765317  
Farr Law Firm P.A.  
901 Ridgewood Avenue  
Venice, FL 34285  
Telephone: (941) 484-3000  
Fax: (941) 485-5173  
E-Mail: dkorszen@farr.com  
Secondary E-Mail:  
jpainchaud@farr.com  
June 26; July 3, 2026 26-01473S

FIRST INSERTION

**NOTICE TO CREDITORS**  
IN THE CIRCUIT COURT FOR  
SARASOTA COUNTY,  
FLORIDA PROBATE DIVISION  
**File No. 2026CP002240NC**  
**Division: PROBATE**  
**IN RE: ESTATE OF**  
**ALICE ELIZABETH RODGERS**  
**GUYTON a/k/a ELIZABETH**  
**RODGERS GUYTON,**  
**Deceased.**

The administration of the estate of Alice Elizabeth Rodgers Guyton a/k/a Elizabeth Rodgers Guyton, deceased, whose date of death was September 8, 2025, is pending in the Circuit Court for Sarasota County, Florida, Probate Division, the address of which is 2000 Main Street, Sarasota, FL 34237. The names and addresses of the personal representative and the personal representative's attorney are set forth below.

All creditors of the decedent and other persons having claims or demands against decedent's estate on whom a copy of this notice is required to be served must file their claims with this court ON OR BEFORE THE LATER OF 3 MONTHS AFTER THE TIME OF THE FIRST PUBLICATION OF THIS NOTICE OR 30 DAYS AFTER THE DATE OF SERVICE OF A COPY OF THIS NOTICE ON THEM.

All other creditors of the decedent and other persons having claims or demands against decedent's estate must file their claims with this court WITHIN 3 MONTHS AFTER THE DATE OF THE FIRST PUBLICATION OF THIS NOTICE.

The personal representative has no

duty to discover whether any property held at the time of the decedent's death by the decedent or the decedent's surviving spouse is property to which the Florida Uniform Disposition of Community Property Rights at Death Act as described in ss. 732.216-732.228, Florida Statutes, applies, or may apply, unless a written demand is made by a creditor as specified under s. 732.2211, Florida Statutes. The written demand must be filed with the clerk.

ALL CLAIMS NOT FILED WITHIN THE TIME PERIODS SET FORTH IN FLORIDA STATUTES SECTION 733.702 WILL BE FOREVER BARRED.

NOTWITHSTANDING THE TIME PERIODS SET FORTH ABOVE, ANY CLAIM FILED TWO (2) YEARS OR MORE AFTER THE DECEDENT'S DATE OF DEATH IS BARRED.

The date of first publication of this notice is June 26, 2026.

**Personal Representative:**

**Mary Evelyn Guyton**  
c/o PAYNE LAW GROUP PLLC  
766 Hudson Ave., Suite C  
Sarasota, FL 34236  
Attorney for Personal Representative:  
David W. Payne, Esq.  
Florida Bar Number: 0958530  
PAYNE LAW GROUP PLLC  
766 Hudson Ave., Suite C  
Sarasota, FL 34236  
Telephone: (941) 487-2800  
Fax: (941) 487-2801  
E-Mail: dpayne@lawnav.com  
Secondary E-Mail:  
nikkimonfils@lawnav.com  
June 26; July 3, 2026 26-01472S

FIRST INSERTION

**NOTICE TO CREDITORS**  
IN THE CIRCUIT COURT FOR  
SARASOTA COUNTY,  
FLORIDA PROBATE DIVISION  
**FILE NO. 2026-CP-003462-NC**  
**IN RE: ESTATE OF**  
**GARY STEPHEN HOLKA,**  
**DECEASED.**

The administration of the estate of GARY STEPHEN HOLKA, deceased, whose date of death was April 17, 2026, is pending in the Circuit Court for Sarasota County, Florida, Probate Division, File Number 2026-CP-003462-NC, the address of which is Clerk of the Circuit Court, Probate Division, P.O. Box 3079, Sarasota, Florida 34230. The names and addresses of the petitioner and the petitioner's attorney are set forth below.

All creditors of the decedent and other persons having claims or demands against decedent's estate on whom a copy of this notice is required to be served must file their claims with this court WITHIN THE LATER OF THREE (3) MONTHS AFTER THE TIME OF THE FIRST PUBLICATION OF THIS NOTICE OR THIRTY (30) DAYS AFTER THE DATE OF SERVICE OF A COPY OF THIS NOTICE ON THEM.

All other creditors of the decedent and other persons having claims or demands against decedent's estate must file their claims with this court WITHIN THREE (3) MONTHS AFTER THE DATE OF THE FIRST PUBLICATION OF THIS NOTICE.

ALL CLAIMS NOT FILED WITHIN

THE TIME PERIODS SET FORTH IN SECTION 733.702 OF THE FLORIDA PROBATE CODE WILL BE FOREVER BARRED.

A petitioner or personal representative or curator has no duty to discover whether any property held at the time of the decedent's death by the decedent or the decedent's surviving spouse is property to which the Florida Uniform Disposition of Community Property Rights at Death Act as described in Sections 732.216-732.228 of the Florida Probate Code applies, or may apply, unless a written demand is made by a creditor as specified under Section 732.2211 of the Florida Probate Code.

NOTWITHSTANDING THE TIME PERIODS SET FORTH ABOVE, ANY CLAIM FILED TWO (2) YEARS OR MORE AFTER THE DECEDENT'S DATE OF DEATH IS BARRED.

The date of first publication of this notice is: June 26, 2026.

**Petitioner:**

**Adrienne Craig,**  
1419 Bardshar Road,  
Sandusky, OH 44870  
Attorney for Petitioner:  
William J. Fuller, III, Esq.  
Florida Bar No. 218626  
Fuller Law Firm  
1058 N. Tamiami Trail, Suite 108-268,  
Sarasota, Florida 34236  
Email address:  
fullerlawfirm@mac.com  
Telephone: 941.955.6446  
Facsimile: 941.296.8900  
June 26; July 3, 2026 26-01474S

FIRST INSERTION

**NOTICE TO CREDITORS**  
**(Summary Administration)**  
IN THE CIRCUIT COURT FOR  
SARASOTA COUNTY,  
FLORIDA  
PROBATE DIVISION  
**File No. 2025 CP 005351 SC**  
**Division PROBATE**  
**IN RE: ESTATE OF**  
**CHARLES I. LAUCKS JR.**  
**A/K/A CHARLES LAUCKS, JR.**  
**Deceased.**

TO ALL PERSONS HAVING CLAIMS OR DEMANDS AGAINST THE ABOVE ESTATE:

You are hereby notified that an Order of Summary Administration has been entered in the estate of CHARLES I. LAUCKS JR. A/K/A CHARLES LAUCKS, JR., deceased, File Number 2025 CP 005351 SC, by the Circuit Court for Sarasota County, Florida, Probate Division, the address of which is 4004 S. Tamiami Trail, Venice, FL 34293; that the decedent's date of death was August 4, 2025; that the total value of the estate is \$20,000.00 and that the names and addresses of those to whom it has been assigned by such order are:

Name	Address
LISA K. MILLER	203 Waldorf Drive York, PA 17404
LORI BARNES	166 Camelot Arms, Bldg. T York, PA 17402

ALL INTERESTED PERSONS ARE NOTIFIED THAT:

All creditors of the estate of the decedent and persons having claims or demands against the estate of the decedent other than those for whom provision for full payment was made in the Order of Summary Administration must file their claims with this court WITHIN THE TIME PERIODS SET FORTH IN FLORIDA STATUTES SECTION 733.702. ALL CLAIMS AND DEMANDS NOT SO FILED WILL BE FOREVER BARRED. NOTWITHSTANDING ANY OTHER APPLICABLE TIME PERIOD, ANY CLAIM FILED TWO (2) YEARS OR MORE AFTER THE DECEDENT'S DATE OF DEATH IS BARRED.

The date of first publication of this Notice is June 26, 2026.

**Person Giving Notice:**

**LISA K. MILLER**  
203 Waldorf Drive  
York, PA 17404  
Attorney for Person Giving Notice  
A. BRENT McPEEK, ESQUIRE  
Attorney for Lisa K. Miller  
Florida Bar Number: 0003905  
3986 S. Tamiami Trail  
Venice, FL 34293  
Telephone: (941) 492-3400  
E-Mail: brent@mcpeeklawfirm.com  
Secondary E-Mail:  
shawn@mcpeeklawfirm.com  
June 26; July 3, 2026 26-01476S

FIRST INSERTION

**NOTICE TO CREDITORS**  
IN THE CIRCUIT COURT OF THE  
TWELFTH JUDICIAL CIRCUIT IN  
AND FOR SARASOTA COUNTY,  
FLORIDA PROBATE DIVISION  
**File No. 2026-CP-003215 NC**  
**IN RE: ESTATE OF**  
**JOSEPH KENT CAPPS, also known**  
**as J. KENT CAPPS,**  
**Deceased.**

The administration of the estate of JOSEPH KENT CAPPS, also known as J. KENT CAPPS, deceased, whose date of death was December 22, 2025, is pending in the Circuit Court for SARASOTA County, FL, Probate Division, the street address of which is Sarasota County Courthouse, 2000 Main Street, Sarasota, Florida 34237-6022 and the mailing address of which is P.O. Box 3079, Sarasota, Florida 34230-3079.

The names and addresses of the personal representative and the personal representative's attorney are set forth below.

All creditors of the decedent and other persons having claims or demands against decedent's estate on whom a copy of this notice is required to be served must file their claims with this court ON OR BEFORE THE LATER OF 3 MONTHS AFTER THE TIME OF THE FIRST PUBLICATION OF THIS NOTICE OR 30 DAYS AFTER THE DATE OF SERVICE OF A COPY OF THIS NOTICE ON THEM.

All other creditors of the decedent and other persons having claims or demands against decedent's estate must file their claims with this court WITHIN 3 MONTHS AFTER THE DATE OF THE FIRST PUBLICATION OF THIS NOTICE.

The personal representative or curator has no duty to discover whether any property held at the time of the decedent's death by the decedent or the decedent's surviving spouse is property to which the Florida Uniform Disposition of Community Property Rights at Death Act as described in ss. 732.216-732.228, Florida Statutes, applies, or may apply, unless a written demand is made by a creditor or a beneficiary as specified under s. 732.2211, Florida Statutes. The written demand must be filed with the clerk.

ALL CLAIMS NOT FILED WITHIN THE TIME PERIODS SET FORTH IN FLORIDA STATUTES SECTION 733.702 WILL BE FOREVER BARRED.

NOTWITHSTANDING THE TIME PERIOD SET FORTH ABOVE, ANY CLAIM FILED TWO (2) YEARS OR MORE AFTER THE DECEDENT'S DATE OF DEATH IS BARRED.

The date of first publication of this notice is: June 26, 2026.

**David Capps**

**Personal Representative**  
2209 Halifax Drive  
Chatham, IL 62629  
Caroline M. Tschida  
Attorney for Personal Representative  
Florida Bar No. 1064556  
BARNES WALKER, GOETHE,  
PERRON, SHEA, & ROBINSON,  
PLLC  
3119 Manatee Avenue West  
Bradenton, FL 34205  
Telephone: (941) 741-8224  
Email: ctschida@barneswalker.com  
Secondary Email:  
mcarmichael@barneswalker.com  
June 26; July 3, 2026 26-01479S

FIRST INSERTION

**NOTICE TO CREDITORS**  
IN THE CIRCUIT COURT FOR  
SARASOTA COUNTY,  
FLORIDA  
PROBATE DIVISION  
**File No. 2026CP002956SC**  
**Division Probate**  
**IN RE: ESTATE OF**  
**JOSEPH A. ANTENUCCI SR**  
**a/k/a JOSEPH A. ANTENUCCI**  
**Deceased.**

The administration of the estate of Joseph A. Antenucci Sr, deceased, whose date of death was February 2, 2026, is pending in the Circuit Court for Sarasota County, Florida, Probate Division, the address of which is P.O. Box 3079, Sarasota, FL 34230. The names and addresses of the personal representative and the personal representative's attorney are set forth below.

All creditors of the decedent and other persons having claims or demands against decedent's estate on whom a copy of this notice is required to be served must file their claims with this court ON OR BEFORE THE LATER OF 3 MONTHS AFTER THE TIME OF THE FIRST PUBLICATION OF THIS NOTICE OR 30 DAYS AFTER THE DATE OF SERVICE OF A COPY OF THIS NOTICE ON THEM.

All other creditors of the decedent and other persons having claims or demands against decedent's estate must file their claims with this court WITHIN 3 MONTHS AFTER THE DATE OF THE FIRST PUBLICATION OF THIS NOTICE.

The personal representative has no

duty to discover whether any property held at the time of the decedent's death by the decedent or the decedent's surviving spouse is property to which the Florida Uniform Disposition of Community Property Rights at Death Act as described in ss. 732.216-732.228, Florida Statutes, applies, or may apply, unless a written demand is made by a creditor as specified under s. 732.2211, Florida Statutes. The written demand must be filed with the clerk.

ALL CLAIMS NOT FILED WITHIN THE TIME PERIODS SET FORTH IN FLORIDA STATUTES SECTION 733.702 WILL BE FOREVER BARRED.

NOTWITHSTANDING THE TIME PERIODS SET FORTH ABOVE, ANY CLAIM FILED TWO (2) YEARS OR MORE AFTER THE DECEDENT'S DATE OF DEATH IS BARRED.

The date of first publication of this notice is June 26, 2026.

**Personal Representative:**

**Steven Antenucci**  
182 N. Clinton Street  
Poughkeepsie, New York 12601  
Attorney for Personal Representative:  
Jeffrey M. Backo  
Attorney  
Florida Bar Number: 0086426  
MELLOR & BACKO LLP  
13801 Tamiami Trail, Suite D  
North Port, Florida 34287  
Telephone: (941) 426-1193  
Fax: (941) 426-5413  
E-Mail: jeff@northportlaw.com  
Secondary: shelly@northportlaw.com  
June 26; July 3, 2026 26-01470S

SAVE TIME



Email your Legal Notice legal@businessobserverfl.com • Deadline Wednesday at noon • Friday Publication

## --- ACTIONS / SALES ---

## FIRST INSERTION

## NOTICE OF SALE

IN THE CIRCUIT COURT OF THE TWELFTH JUDICIAL CIRCUIT OF FLORIDA, IN AND FOR SARASOTA COUNTY CIVIL DIVISION

Case No. 2024-CA-005598

Division NC  
WILMINGTON SAVINGS FUND SOCIETY, FSB, AS INDENTURE TRUSTEE WITH RESPECT TO CIM TRUST 2023-R1 Plaintiff, vs.

ANITA M. LEACH A/K/A ANITA LEACH, JENNIFER N. LEACH, CHRISTOPHER A. LEACH, ELIZABETH M. LEACH, UNKNOWN SPOUSE OF ANITA M. LEACH A/K/A ANITA LEACH, UNKNOWN SPOUSE OF JENNIFER N. LEACH, UNKNOWN SPOUSE OF CHRISTOPHER A. LEACH, UNKNOWN SPOUSE OF ELIZABETH M. LEACH, AND UNKNOWN TENANTS/OWNERS, Defendants.

Notice is hereby given, pursuant to Final Judgment of Foreclosure for Plaintiff entered in this cause on April 15, 2026, in the Circuit Court of Sarasota County, Florida, Karen E. Rushing, Clerk of the Circuit Court, will seal the property situated in Sarasota County, Florida described as:

LOT 5, BLOCK 56, VENICE BYWAY, AS PER PLAT THEREOF RECORDED IN PLAT BOOK 2, PAGE 61, OF THE PUBLIC RECORDS OF SARASOTA COUNTY, FLORIDA.

TY, FLORIDA.

TOGETHER WITH THAT CERTAIN 2006 FLEETWOOD MOBILE HOME, VIN(S) FL-FL670A32948LF31A & FL-FL670A32948LF31B

and commonly known as: 205 PORTIA ST S, NOKOMIS, FL 34275; including the building, appurtenances, and fixtures located therein, at public sale, to the highest and best bidder, for cash, www.sarasota.realforeclose.com, on July 23, 2026 9:00 A.M..

Any persons claiming an interest in the surplus from the sale, if any, other than the property owner as of the date of the lis pendens must file a claim before the clerk reports the surplus as unclaimed.

If you are a person with a disability who needs any accommodation in order to participate in this proceeding, you are entitled, at no cost to you, to the provision of certain assistance. Please contact the Sarasota County Jury Office, P.O. Box 3079, Sarasota, Florida 34230-3079, (941)861-7400, at least seven (7) days before your scheduled court appearance, or immediately upon receiving this notification if the time before the scheduled appearance is less than seven (7) days; if you are hearing or voice impaired, call 711.

Dated: June 17, 2026

By: /s/ David R. Byars

David R. Byars

Attorney for Plaintiff

320250/2426334/wll

June 26; July 3, 2026 26-014345

## FIRST INSERTION

## NOTICE OF ACTION

IN THE COUNTY COURT OF THE TWELFTH JUDICIAL CIRCUIT IN AND FOR SARASOTA COUNTY FLORIDA

CIVIL ACTION

Case No. 2025 CC 007874 NC

SARASOTA SANDS OWNERS ASSOCIATION, INC., Plaintiff, v.

ETHEL J. YOPS, Defendant.

TO: ETHEL J. YOPS and if any of the above named natural persons be married, their unknown spouses, and if any of the above named natural persons be dead, their unknown heirs, devisees, grantees, successors or other parties claiming by, through, under or against them, and any and all other persons claiming any right, title, interest, lien, estate or demand in or to be the following described real property and to reform a certain deed, situate, lying and being in Sarasota County, Florida, to-wit:

An undivided 1/50th interest in and to Condominium Unit A231 Week 48 and its undivided respective share in those common elements appertaining thereto in accordance with and subject to the covenants, conditions, terms restrictions and other provisions of a certain Declaration of Condominium of SARASOTA SANDS, a resort condominium hotel, as recorded in Official Records Book 1364 at Page 1165 et seq. of the Public Records of Sarasota County, Florida, and as per Condominium Plat recorded

in Condominium Book 14 at Pages 4 through 4B, inclusive, of the public records of Sarasota County, Florida.

YOU ARE HEREBY notified that a foreclosure action on the above described property has been filed against you in the above entitled Court and you are required to serve a copy of your written defenses to the Complaint on the Plaintiff's Attorney, DAVID K. OAKS, ESQ., of DAVID K. OAKS, P.A., P. O. Box 671, Saluda, NC 28773, and file the original with the Clerk of the Court, Sarasota County Courthouse, 2000 Main Street, Sarasota, FL 34237 on or before the 27 day of July, 2026, otherwise a judgment may be entered against you for the relief demanded in the Complaint.

If you are a person with a disability who needs any accommodation in order to participate in this proceeding, you are entitled, at no cost to you, to the provision of certain assistance. Please contact the Sarasota County Jury Office, P.O. Box 3079, Sarasota, Florida 34230-3079, (941)861-7400, at least seven (7) days before your scheduled court appearance, or immediately upon receiving this notification if the time before the scheduled appearance is less than seven (7) days; if you are hearing or voice impaired, call 711.

Witness my hand and seal of said Court on this 15 day of June, 2026.

KAREN E. RUSHING

Clerk of the Court

(SEAL) BY G. KOPINSKY

Deputy Clerk

June 26; July 3, 10, 17, 2026 26-014265

## FIRST INSERTION

## NOTICE OF ACTION -

CONSTRUCTIVE SERVICE IN THE CIRCUIT COURT OF THE TWELFTH JUDICIAL CIRCUIT IN AND FOR SARASOTA COUNTY, FLORIDA

GENERAL JURISDICTION DIVISION

Case No. 2026 CA 002282 NC

U.S. BANK TRUST NATIONAL ASSOCIATION, NOT IN ITS INDIVIDUAL CAPACITY BUT SOLELY IN ITS CAPACITY AS OWNER TRUSTEE ON BEHALF OF BREAN ASSET BACKED SECURITIES TRUST 2024-RM9, Plaintiff, vs.

THE UNKNOWN HEIRS, BENEFICIARIES, DEVISEES, GRANTEE, ASSIGNEES, LIENORS, CREDITORS, TRUSTEES AND ALL OTHERS WHO MAY CLAIM AN INTEREST IN THE ESTATE OF JANE A. LOENSER, DECEASED, et. al. Defendant(s).

TO: THE UNKNOWN HEIRS, BENEFICIARIES, DEVISEES, GRANTEE, ASSIGNEES, LIENORS, CREDITORS, TRUSTEES AND ALL OTHERS WHO MAY CLAIM AN INTEREST IN THE ESTATE OF JANE A. LOENSER, DECEASED, whose residence is unknown if he/she they be living; and if he/she/they be dead, the unknown defendants who may be spouses, heirs, devisees, grantees, assignees, lienors, creditors, trustees, and all parties claiming an interest by, through, under or against the Defendants, who are not known to be dead or alive, and all parties having or claiming to have any right, title or interest in the property described in the mortgage being foreclosed herein.

TO: WILLIAM SPELL, whose residence is unknown and all parties having or claiming to have any right, title or interest in the property described in the mortgage being foreclosed herein.

YOU ARE HEREBY NOTIFIED that an action to foreclose a mortgage on the following property:

LOT 1072, UNIT NO. 19, VENICE GARDENS, AS PER PLAT THEREOF RECORDED IN PLAT BOOK 11, PAGE 11, OF THE PUBLIC RECORDS OF SARASOTA COUNTY, FLORIDA.

has been filed against you and you are required to serve a copy of your written defenses, if any, to it on counsel for Plaintiff, whose address is 6409 Congress Ave., Suite 100, Boca Raton, Florida 33487 on or before 7-27-2026 (30 days from Date of First Publication of this Notice) and file the original with the clerk of this court either before service on Plaintiff's attorney or immediately thereafter; otherwise a default will be entered against you for the relief demanded in the complaint or petition filed herein.

If you are a person with a disability who needs any accommodation in order to participate in this proceeding, you are entitled, at no cost to you, to the provision of certain assistance. Please contact the Sarasota County Jury Office, P.O. Box 3079, Sarasota, Florida 34230-3079, (941)861-7400, at least seven (7) days before your scheduled court appearance, or immediately upon receiving this notification if the time before the scheduled appearance is less than seven (7) days; if you are hearing or voice impaired, call 711.

WITNESS my hand and the seal of this Court at Sarasota County, Florida, this 17 day of June, 2026.

KAREN E. RUSHING

CLERK OF THE CIRCUIT COURT

BY: GLEN KOPINSKY

DEPUTY CLERK

ROBERTSON, ANSCHUTZ, AND SCHNEID, PL

ATTORNEY FOR PLAINTIFF

6409 Congress Ave., Suite 100

Boca Raton, FL 33487

PRIMARY EMAIL: flmail@raslg.com

26-393925

June 26; July 3, 2026 26-014295

## FIRST INSERTION

## NOTICE OF ACTION

IN THE CIRCUIT COURT OF THE TWELFTH JUDICIAL CIRCUIT IN AND FOR SARASOTA COUNTY, FLORIDA

Case No.: 2026 CA 001616

ROCKET MORTGAGE, LLC, Plaintiff, vs.

OLGA CHERNOVOL; et al., Defendant(s).

TO: Olga Chernovol

Last Known Residence: 7308 Ne 217 Ave Vancouver, WA 98682

TO: Unknown Spouse of Olga Chernovol

Last Known Residence: 78057 Cristobal Ave North Port, FL 34287

YOU ARE NOTIFIED that an action to foreclose a mortgage on the following property in SARASOTA County, Florida:

LOT 3, BLOCK 1910, FIRST REPLAT IN FORTY FIRST ADDITION TO PORT CHARLOTTE SUBDIVISION, ACCORDING TO THE MAP OR PLAT THEREOF, AS RECORDED IN PLAT BOOK 17, PAGE(S) 36, OF THE PUBLIC RECORDS OF SARASOTA COUNTY, FLORIDA

has been filed against you and you are required to serve a copy of your written defenses, if any, to it on ALDRIDGE PITE, LLP, Plaintiff's attorney, at 401 W. Linton Blvd. Suite 202-B Delray Beach, FL 33444, on or before July 27, 2026, and file the original with the clerk of this court either before service on Plaintiff's attorney or immediately thereafter; otherwise a default will be entered against you for the relief demanded in the complaint or petition.

If you are a person with a disability who needs any accommodation in order to participate in this proceeding, you are entitled, at no cost to you, to the provision of certain assistance. Please contact the Sarasota County Jury Office, P.O. Box 3079, Sarasota, Florida 34230-3079, (941)861-7400, at least seven (7) days before your scheduled court appearance, or immediately upon receiving this notification if the time before the scheduled appearance is less than seven (7) days; if you are hearing or voice impaired, call 711.

TO: KAREN E. RUSHING, CLERK As Clerk of the Court (SEAL) By: G. Kopsinsky As Deputy Clerk

1190-072B Ref# 19432

June 26; July 3, 2026 26-014285

## FIRST INSERTION

## NOTICE OF ACTION

IN THE CIRCUIT COURT OF THE 12TH JUDICIAL CIRCUIT IN AND FOR SARASOTA COUNTY, FLORIDA

Case No.: 2026-CA-000841

PLANET HOME LENDING LLC, Plaintiff, v.

RANDOLPH S. QUALLS; et al, Defendant(s).

To the following Defendant(s): KIMBERLY ANN QUALLS (Last Known Address: 5842 Calla Lilly Dr, Sarasota, FL 34232)

RANDOLPH S. QUALLS (Last Known Address: 5842 Calla Lilly Dr, Sarasota, FL 34232)

UNKNOWN SPOUSE OF RANDOLPH S. QUALLS (Last Known Address: 5842 Calla Lilly Dr, Sarasota, FL 34232)

UNKNOWN TENANT #1 (Last Known Address: 5842 Calla Lilly Dr, Sarasota, FL 34232)

UNKNOWN TENANT #2 (Last Known Address: 5842 Calla Lilly Dr, Sarasota, FL 34232)

YOU ARE NOTIFIED that an action to foreclose based on boundaries established by acquiescence, on the following described property:

LOT 130, GARDEN VILLAGE PHASE 2, ACCORDING TO THE PLAT AS RECORDED IN PLAT BOOK 53, PAGES 40 THROUGH 42, OF THE PUBLIC RECORDS OF SARASOTA

COUNTY, FLORIDA. PROPERTY ADDRESS: 5842 CALLA LILLY DR, SARASOTA, FL 34232

has been filed against you and you are required to serve a copy of your written defenses, if any, to it, on Ghidotti | Berger LLP, Attorney for Plaintiff, whose address is 10800 Biscayne Blvd., Suite 201, Miami, FL 33161 7-27-2026, a date which is within thirty (30) days after the first publication of this Notice in the Business Observer and file the original with the Clerk of this Court either before service on Plaintiff's attorney or immediately thereafter; otherwise a default will be entered against you for the relief demanded in the complaint.

This notice is provided pursuant to Administrative Order No. 2010-08

If you are a person with a disability who needs any accommodation in order to participate in this proceeding, you are entitled, at no cost to you, to the provision of certain assistance. Please contact the Sarasota County Jury Office, P.O. Box 3079, Sarasota, Florida 34230-3079, (941)861-7400, at least seven (7) days before your scheduled court appearance, or immediately upon receiving this notification if the time before the scheduled appearance is less than seven (7) days; if you are hearing or voice impaired, call 711.

WITNESS my hand and the seal of this Court this 19 day of June, 2026.

KAREN E. RUSHING As Clerk of the Court (SEAL) By G. Kopsinsky As Deputy Clerk

June 26; July 3, 2026 26-014425

## FIRST INSERTION

## NOTICE OF ACTION

CONSTRUCTIVE SERVICE - PROPERTY IN THE CIRCUIT COURT OF THE TWELFTH JUDICIAL CIRCUIT IN AND FOR SARASOTA COUNTY, FLORIDA

CIVIL ACTION

Case No.: 2026CA002759NC

DIVISION "C"

NEW VISTA PROPERTIES, INC., a Florida Corporation, Plaintiff, vs.

CARLOS FANA-PENA and EVELYN L. ALCANTARA-MICHELI, their devisees, grantees, creditors, and all other parties claiming by, through, under or against them and all unknown natural persons, if alive and if now known to be or alive, their several and respective spouses, heirs, devisees, grantees, and other creditors or other parties claiming by, through, under or against them or their legal entity named as a defendant and all claimants, persons or parties natural or corporate whose exact status is unknown, claiming under any of the above named or described defendants or parties who are claiming to have any right, title or interest in and to the lands hereafter described; UNKNOWN SPOUSE OF CARLOS FANA-PENA; and UNKNOWN SPOUSE OF EVELYN L. ALCANTARA-MICHELI.

YOU ARE HEREBY NOTIFIED that an action to foreclose on the following described property in Sarasota County, Florida:

Lot 3, Block 2188, Forty-Sixth Addition to Port Charlotte Subdivision, according to the map or plat thereof, as recorded in Plat Book 19, Page(s) 45, of the Public Records of Sarasota County, Florida

has been filed against you and you are required to serve a copy of your written defenses, if any, to it on Albert J. Tiseo, Jr., Plaintiff's attorney whose address is Goldman, Tiseo & Sturges, P.A., 701 JC Center Court, Suite 3, Port Charlotte, Florida 33954, thirty (30) days after the first publication date, and file the original with the Clerk of this Court either before service on Plaintiff's attorney or immediately thereafter; otherwise a default will be entered against you for the relief demanded in the Complaint.

If you are a person with a disability who needs any accommodation in order to participate in this proceeding, you are entitled, at no cost to you, to the provision of certain assistance. Please contact the Sarasota County Jury Office, P.O. Box 3079, Sarasota, Florida 34230-3079, (941)861-7400, at least seven (7) days before your scheduled court appearance, or immediately upon receiving this notification if the time before the scheduled appearance is less than seven (7) days; if you are hearing or voice impaired, call 711.

WITNESS my hand and seal of this Court June 19, 2026.

KAREN E. RUSHING CLERK OF THE COURT (SEAL) By: G. Kopsinsky Deputy Clerk

June 26; July 3, 2026 26-014435

## FIRST INSERTION

## NOTICE OF ACTION

IN THE CIRCUIT COURT OF THE TWELFTH JUDICIAL CIRCUIT IN AND FOR SARASOTA COUNTY, FLORIDA

Case No: 2026 CA 002813 NC

Agency Case No.: 26-015249

IN RE: THE FORFEITURE OF: \$11,485.00 IN U.S. CURRENCY AND 100 OZ SILVER BAR

A PETITION OF THE CITY OF SARASOTA f/b/o THE SARASOTA POLICE DEPARTMENT

TO ALL PERSONS OR ENTITIES HAVING OR CLAIMING TO HAVE ANY RIGHT, TITLE OR INTEREST IN THE PROPERTY HEREIN DESCRIBED:

YOU ARE NOTIFIED that an action pursuant to the Florida Contraband Forfeiture Act has been filed by PETITIONER, on the following property in Sarasota County, Florida: Eleven Thousand Four Hundred Eighty-Five Dollars and 00/100 cents in U.S. Currency (\$11,485.00) and One Hundred Ounce (100 oz) Johnson Matthey Silver Bar, and you are required to serve a copy of your written defenses to it, if any, on Joseph J. Polzak, Esq., PETITIONER'S attorney, whose address is

P.O. Box 1000, Sarasota, FL 34236, on or before the 27 day of July 2026, and file the original with the Clerk of this Court either before Service on PETITIONER'S attorney or immediately thereafter; otherwise a default will be entered against you for the relief demanded in the complaint.

If you are a person with a disability who needs any accommodation in order to participate in this proceeding, you are entitled, at no cost to you, to the provision of certain assistance. Please contact the Sarasota County Jury Office, P.O. Box 3079, Sarasota, Florida 34230-3079, (941)861-7400, at least seven (7) days before your scheduled court appearance, or immediately upon receiving this notification if the time before the scheduled appearance is less than seven (7) days; if you are hearing or voice impaired, call 711.

Dated June 15, 2026

KAREN E. RUSHING, CLERK OF THE CIRCUIT COURT-SARASOTA

P.O. Box 3079 Sarasota, Florida 34230 (SEAL) By G. Kopsinsky Deputy Clerk

June 26; July 3, 2026 26-014275

## FIRST INSERTION

## NOTICE OF ACTION

IN THE CIRCUIT COURT OF THE 12TH JUDICIAL CIRCUIT IN AND FOR SARASOTA COUNTY, FLORIDA

Case No.: 2026 CA 002644 NC

DEUTSCHE BANK NATIONAL TRUST COMPANY, AS TRUSTEE FOR HOME EQUITY MORTGAGE LOAN ASSET-BACKED TRUST SERIES INABS 2005-D, HOME EQUITY MORTGAGE LOAN ASSET-BACKED CERTIFICATES SERIES INABS 2005-D, Plaintiff, vs.

STEWART J. DENNY A/K/A STEWART DENNY; GINA M. DENNY A/K/A GINA DENNY, Defendant(s).

TO: Stewart J. Denny a/k/a Stewart Denny

Residence Unknown

Gina M. Denny a/k/a Gina Denny

Residence Unknown

YOU ARE NOTIFIED that an action to foreclose a mortgage on the following described property in Sarasota County, Florida:

LOT 6, BLOCK 70, SOUTH GATE, UNIT 18, AS PER PLAT THEREOF RECORDED IN PLAT BOOK 9, PAGE 69, OF THE PUBLIC RECORDS OF SARASOTA COUNTY, FLORIDA.

Street Address: 3724 Thornton Place, Sarasota, Florida 34239

has been filed against you and you are required to serve a copy of your written defenses, if any, to it on McCabe, Weisberg & Conway, LLC, Plaintiff's attorney, whose address is 3222 Commerce Place, Suite A, West Palm Beach, FL 33407, within 30 days after the date of the first publication of this notice, on or before July 27, 2026, and file the original with the Clerk of this Court, otherwise, a default will be entered against you for the relief demanded in the complaint or petition.

If you are a person with a disability who needs any accommodation in order to participate in this proceeding, you are entitled, at no cost to you, to the provision of certain assistance. Please contact the Sarasota County Jury Office, P.O. Box 3079, Sarasota, Florida 34230-3079, (941)861-7400, at least seven (7) days before your scheduled court appearance, or immediately upon receiving this notification if the time before the scheduled appearance is less than seven (7) days; if you are hearing or voice impaired, call 711.

Dated on June 18, 2026.

Karen E. Rushing Clerk of said Court

By: G. Kopsinsky (SEAL) As Deputy Clerk

McCabe, Weisberg & Conway, LLC 3222 Commerce Place, Suite A West Palm Beach, FL 33407 Telephone: (561) 713-1400 FLpleadings@MWC-law.com File#:20-40149

June 26; July 3, 2026 26-014385

## FIRST INSERTION

## NOTICE OF SALE

IN THE COUNTY COURT OF THE TWELFTH JUDICIAL CIRCUIT IN AND FOR SARASOTA COUNTY, FLORIDA

Case No. 2025 CC 010324 NC

STONEBROOK AT VENICE COMMUNITY ASSOCIATION, INC. Plaintiff, v.

CHRISTOPHER BOWMAN; UNKNOWN SPOUSE OF CHRISTOPHER BOWMAN, AS UNKNOWN SPOUSE OR OCCUPANT IN POSSESSION; TENANT OR OCCUPANT #1, AS UNKNOWN TENANT OR OCCUPANT IN POSSESSION; and TENANT OR OCCUPANT #2, AS UNKNOWN TENANT OR OCCUPANT IN POSSESSION, Defendant.

NOTICE IS HEREBY GIVEN pursuant to the Summary Final Judgment of Foreclosure entered on June 16, 2026, and entered in Case No. 2025 CC 0010324 NC, in the County Court of the Twelfth Judicial Circuit in and for Sarasota County, Florida, wherein STONEBROOK AT VENICE COMMUNITY ASSOCIATION, INC., a Florida not-for-profit corporation is the Plaintiff and CHRISTOPHER BOWMAN; KATZ BATES, AS UNKNOWN SPOUSE OR OCCUPANT IN POSSESSION are Defendants, KAREN E. RUSHING, Sarasota County Clerk of Courts will sell to the highest and best bidder for cash at www.sarasota.realforeclose.com at 9:00 am on July 30, 2026, the following described property set forth in said Final Judgment, to wit:

Lot 2083, STONEYBROOK AT VENICE, UNIT 4, according to map or plat thereof as recorded in Plat Book 45, Page 28, of the Public Records of Sarasota County, Florida.

With an address of: 11730 Tempest Harbor Loop, Venice, Florida 34292

Any person or entity claiming an interest in the surplus, if any, resulting from the Foreclosure Sale, other than the property owner as of the date of the Lis Pendens, must file a claim with the Clerk no later than the date that the Clerk reports the funds are unclaimed. If you fail to file a claim, you will not be entitled to any remaining funds.

If the sale is set aside, the Purchaser may be entitled to only a return of the sale deposit less any applicable fees and costs and shall have no other records against the Plaintiff, Defendants or

their attorneys.

IF THIS PROPERTY IS SOLD AT PUBLIC AUCTION, THERE MAY BE ADDITIONAL MONEY FROM THE SALE AFTER PAYMENT OF PERSONS WHO ARE ENTITLED TO BE PAID FROM THE SALE PROCEEDS PURSUANT TO THIS FINAL JUDGMENT.

IF YOU ARE THE PROPERTY OWNER, YOU MAY CLAIM THESE FUNDS YOURSELF. YOU ARE NOT REQUIRED TO HAVE A LAWYER OR ANY OTHER REPRESENTATION AND YOU DO NOT HAVE TO ASSIGN YOUR RIGHTS TO ANYONE ELSE IN ORDER FOR YOU TO CLAIM ANY MONEY TO WHICH YOU ARE ENTITLED. PLEASE CHECK WITH THE CLERK OF THE COURT OF SARASOTA COUNTY, WITHIN TEN (10) DAYS AFTER THE SALE TO SEE IF THERE IS ADDITIONAL MONEY FROM THE FORECLOSURE SALE THAT THE CLERK HAS IN THE REGISTRY OF THE COURT.

IF YOU ARE A SUBORDINATE LIENHOLDER CLAIMING A RIGHT TO FUNDS REMAINING AFTER THE SALE, IF ANY, YOU MUST FILE A CLAIM WITH THE CLERK NO LATER THAN THE DATE THAT THE CLERK REPORTS THE FUNDS AS UNCLAIMED. IF YOU FAIL TO FILE A TIMELY CLAIM, YOU WILL NOT BE ENTITLED TO ANY REMAINING FUNDS.

If you are a

--- ACTIONS / SALES ---

FIRST INSERTION

**NOTICE OF ACTION  
CONSTRUCTIVE SERVICE -  
PROPERTY**

THE CIRCUIT COURT OF THE  
TWELFTH JUDICIAL CIRCUIT  
IN AND FOR SARASOTA COUNTY,  
FLORIDA  
CIVIL ACTION  
CASE NO.: 2026CA002749NC  
DIVISION "C"

**NEW VISTA PROPERTIES, INC.,**  
a Florida Corporation,  
Plaintiff, vs.  
**AUDETH FENDER-HOBBS;**  
her devisees, grantees, creditors,  
and all other parties claiming by,  
through, under or against her and  
all unknown natural persons, if  
alive and if now known to be or  
alive, their several and respective  
spouses, heirs, devisees, grantees,  
and other creditors or other parties  
claiming by, though, or under those  
unknown natural persons and their  
several unknown assigns, successors  
in interest trustees, or any other  
persons claiming by through, under  
or against any corporation or other  
legal entity named as a defendant  
and all claimants, persons or parties  
natural or corporate whose exact  
status is unknown, claiming under  
any of the above named or described  
defendants or parties who are  
claiming to have any right, title or  
interest in and to the lands hereafter  
described; and UNKNOWN  
SPOUSE OF AUDETH FENDER-  
HOBBS,  
Defendants.  
TO: AUDETH FENDER-HOBBS;  
her devisees, grantees, creditors, and  
all other parties claiming by, through,  
under or against her and all unknown  
natural persons, if alive and if now  
known to be or alive, their several and  
respective spouses, heirs, devisees,  
grantees, and other creditors or other  
parties claiming by, though, or under  
those unknown natural persons and  
their several unknown assigns, successors  
in interest trustees, or any other persons  
claiming by through, under or against  
any corporation or other legal entity

named as a defendant and all claimants,  
persons or parties natural or corporate  
whose exact status is unknown,  
claiming under any of the above named  
or described defendants or parties who  
are claiming to have any right, title or  
interest in and to the lands hereafter  
described; and UNKNOWN SPOUSE OF  
AUDETH FENDER-HOBBS:  
YOU ARE HEREBY NOTIFIED  
that an action to foreclose on the following  
described property in Sarasota  
County, Florida:

Lot 15, Block 2080, FORTY-  
FIFTH ADDITION TO PORT  
CHARLOTTE SUBDIVISION,  
according to the map or plat  
thereof, as recorded in Plat Book  
19, Page(s) 38, of the Public  
Records of Sarasota County, Florida  
has been filed against you and you are  
required to serve a copy of your written  
defenses, if any, to it on Albert J. Tiseo,  
Jr., Plaintiff's attorney whose address is  
Goldman, Tiseo & Sturges, P.A., 701 JC  
Center Court, Suite 3, Port Charlotte,  
Florida 33954, thirty (30) days after the  
first publication date, and file the original  
with the Clerk of this Court either  
before service on Plaintiff's attorney or  
immediately thereafter; otherwise a default  
will be entered against you for the relief  
demanded in the Complaint.

If you are a person with a disability  
who needs any accommodation in  
order to participate in this proceeding,  
you are entitled, at no cost to you,  
to the provision of certain assistance.  
Please contact the Sarasota County  
Jury Office, P.O. Box 3079, Sarasota,  
Florida 34230-3079, (941)861-7400, at  
least seven (7) days before your scheduled  
court appearance, or immediately  
upon receiving this notification if the  
time before the scheduled appearance  
is less than seven (7) days; if you are  
hearing or voice impaired, call 711.

WITNESS my hand and seal of this  
Court June 19, 2026.

KAREN E. RUSHING  
CLERK OF THE COURT  
(SEAL) By: G. Kopinsky  
Deputy Clerk  
June 26; July 3, 2026 26-01445S

**NOTICE OF ACTION  
CONSTRUCTIVE SERVICE -  
PROPERTY**

THE CIRCUIT COURT OF THE  
TWELFTH JUDICIAL CIRCUIT  
IN AND FOR SARASOTA COUNTY,  
FLORIDA  
CIVIL ACTION  
CASE NO.: 2026-CA-002756-NC  
DIVISION "A"

**NEW VISTA PROPERTIES, INC.,**  
a Florida Corporation,  
Plaintiff, vs.  
**PEDRO ROSSEL;** his devisees,  
grantees, creditors, and all other  
parties claiming by, through, under  
or against him and all unknown  
natural persons, if alive and if  
now known to be or alive, their  
several and respective spouses,  
heirs, devisees, grantees, and other  
creditors or other parties claiming  
by, though, or under those unknown  
natural persons and their several  
unknown assigns, successors in  
interest trustees, or any other  
persons claiming by through, under  
or against any corporation or other  
legal entity named as a defendant  
and all claimants, persons or parties  
natural or corporate whose exact  
status is unknown, claiming under  
any of the above named or described  
defendants or parties who are  
claiming to have any right, title or  
interest in and to the lands hereafter  
described; and UNKNOWN  
SPOUSE OF PEDRO ROSSEL,  
Defendants.  
TO: PEDRO ROSSEL; his devisees,  
grantees, creditors, and all other  
parties claiming by, through, under  
or against him and all unknown  
natural persons, if alive and if now  
known to be or alive, their several and  
respective spouses, heirs, devisees,  
grantees, and other creditors or other  
parties claiming by, though, or under  
those unknown natural persons and  
their several unknown assigns, successors  
in interest trustees, or any other persons  
claiming by through, under or against  
any corporation or other legal entity  
named as a defendant and all claimants,  
persons or

parties natural or corporate whose exact  
status is unknown, claiming under  
any of the above named or described  
defendants or parties who are claiming  
to have any right, title or interest  
in and to the lands hereafter described;  
and UNKNOWN SPOUSE OF PEDRO  
ROSSEL:

YOU ARE HEREBY NOTIFIED  
that an action to foreclose on the following  
described property in Sarasota  
County, Florida:

Lot 2, Block 2195, FORTY-  
SIXTH ADDITION TO PORT  
CHARLOTTE SUBDIVISION,  
according to the map or plat  
thereof, as recorded in Plat Book  
19, Page(s) 45, of the Public  
Records of Sarasota County, Florida  
has been filed against you and you are  
required to serve a copy of your written  
defenses, if any, to it on Albert J. Tiseo,  
Jr., Plaintiff's attorney whose address is  
Goldman, Tiseo & Sturges, P.A., 701 JC  
Center Court, Suite 3, Port Charlotte,  
Florida 33954, thirty (30) days after the  
first publication date, and file the original  
with the Clerk of this Court either  
before service on Plaintiff's attorney or  
immediately thereafter; otherwise a default  
will be entered against you for the relief  
demanded in the Complaint.

If you are a person with a disability  
who needs any accommodation in order  
to participate in this proceeding, you are  
entitled, at no cost to you, to the  
provision of certain assistance. Please  
contact the Sarasota County  
Jury Office, P.O. Box 3079, Sarasota,  
Florida 34230-3079, (941)861-7400,  
at least seven (7) days before your  
scheduled court appearance, or immediately  
upon receiving this notification if the  
time before the scheduled appearance  
is less than seven (7) days; if you are  
hearing or voice impaired, call 711.

WITNESS my hand and seal of this  
Court June 19, 2026.

KAREN E. RUSHING  
CLERK OF THE COURT  
(SEAL) By: G. Kopinsky  
Deputy Clerk  
June 26; July 3, 2026 26-01444S

FIRST INSERTION

**NOTICE OF SALE  
IN THE CIRCUIT COURT OF THE  
TWELFTH JUDICIAL CIRCUIT  
IN AND FOR SARASOTA COUNTY,  
FLORIDA  
CIVIL DIVISION  
Case #: 2025 CA 001902 NC  
DIVISION: A**

**1 Sharpe Opportunity Intermediate  
Trust  
Plaintiff, -vs.-  
Eco Holdings Investments, LLC;  
Donato Ciaccia; Unknown Parties  
in Possession #1, as to 873 Riviera  
Lane, Port Charlotte, FL 33948,  
if living, and all Unknown Parties  
claiming by, through, under  
and against the above named  
Defendant(s); Unknown Parties  
in Possession #2, as to 873 Riviera  
Lane, Port Charlotte, FL 33948,  
if living, and all Unknown Parties  
claiming by, through, under  
and against the above named  
Defendant(s); Unknown Parties  
in Possession #1, as to 5039 Brack  
Avenue, North Port, FL 34288, if  
living, and all Unknown Parties  
claiming by, through, under  
and against the above named  
Defendant(s); Unknown Parties  
in Possession #2, as to 5039 Brack  
Avenue, North Port, FL 34288, if  
living, and all Unknown Parties  
claiming by, through, under  
and against the above named  
Defendant(s); Freedom Forever FL  
LLC  
Defendant(s).**

NOTICE IS HEREBY GIVEN pursuant  
to order rescheduling foreclosure sale or  
Final Judgment, entered in Civil Case  
No. 2025 CA 001902 NC of the Circuit  
Court of the 12th Judicial Circuit in and  
for Sarasota County, Florida, wherein  
1 Sharpe Opportunity Intermediate  
Trust, Plaintiff and Eco Holdings  
Investments, LLC are defendant(s), I,  
Clerk of Court, Karen E. Rushing, will  
sell to the highest and best bidder for  
cash VIA THE INTERNET AT WWW.  
SARASOTA.REALFORECLOSE.COM  
, AT 9:00 A.M. on July 30, 2026, the  
following described property as set  
forth in said Final Judgment, to-wit:  
PARCEL 1: LOT 20, BLOCK  
4292, PORT CHARLOTTE  
SUBDIVISION SECTION  
SIXTY SIX, ACCORDING TO

THE PLAT THEREOF, AS  
RECORDED IN PLAT BOOK  
6, PAGES 4A THROUGH 4G,  
INCLUSIVE, OF THE PUBLIC  
RECORDS OF CHARLOTTE  
COUNTY, FLORIDA.  
PARCEL 2: LOT 5, BLOCK 379,  
PORT CHARLOTTE SUBDI-  
VISION, SECTION TWENTY  
THREE, ACCORDING TO  
THE PLAT THEREOF, AS RE-  
CORDED IN PLAT BOOK 5,  
PAGES 14A THROUGH 14E,  
INCLUSIVE, OF THE PUBLIC  
RECORDS OF CHARLOTTE  
COUNTY, FLORIDA.  
PARCEL 3: LOT 10, BLOCK  
1057, TWENTY FOURTH AD-  
DITION TO PORT CHAR-  
LOTTE SUBDIVISION, AC-  
CORDING TO THE PLAT  
THEREOF, AS RECORDED IN  
PLAT BOOK 14, PAGES 14, 14A  
THROUGH 14M, INCLUSIVE,  
OF THE PUBLIC RECORDS OF  
SARASOTA COUNTY,  
FLORIDA.

ANY PERSON CLAIMING AN  
INTEREST IN THE SURPLUS FROM  
THE SALE, IF ANY, OTHER THAN  
THE PROPERTY OWNER AS OF  
THE DATE OF THE LIS PENDENS  
MUST FILE A CLAIM NO LATER  
THAN THE DATE THAT THE  
CLERK REPORTS THE FUNDS AS  
UNCLAIMED.

If you are a person with a disability  
who needs any accommodation in  
order to participate in this proceed-  
ing, you are entitled, at no cost to you,  
to the provision of certain assistance.  
Please contact the Sarasota County  
Jury Office, P.O. Box 3079, Sarasota,  
Florida 34230-3079, (941)861-7400, at  
least seven (7) days before your sched-  
uled court appearance, or immediately  
upon receiving this notification if the  
time before the scheduled appearance  
is less than seven (7) days; if you are  
hearing or voice impaired, call 711.  
Submitted By: ATTORNEY FOR  
PLAINTIFF:  
LOGS LEGAL GROUP LLP  
750 Park of Commerce Blvd., Suite 130  
Boca Raton, Florida 33487  
(561) 998-6700  
(561) 998-6707  
25-332482 FCO1 948  
June 26; July 3, 2026 26-01475S

FIRST INSERTION

**NOTICE AND AGREED ORDER TO  
SHOW CAUSE**

IN THE CIRCUIT COURT  
OF THE TWELFTH JUDICIAL  
CIRCUIT OF FLORIDA, IN  
AND FOR SARASOTA COUNTY,  
FLORIDA

CASE NO: 58-2026 CA 002690 NC  
VENICE GRAND OAKS  
COMMUNITY DEVELOPMENT  
DISTRICT, a local unit of special-  
purpose government organized and  
existing under the laws of the State  
of Florida,  
Plaintiff, v.  
THE STATE OF FLORIDA, AND  
THE TAXPAYERS, PROPERTY  
OWNERS AND CITIZENS  
OF VENICE GRAND OAKS  
COMMUNITY DEVELOPMENT  
DISTRICT, INCLUDING NON-  
RESIDENTS OWNING PROPERTY  
OR SUBJECT TO TAXATION  
THEREIN, AND OTHERS  
HAVING OR CLAIMING ANY  
RIGHTS, TITLE OR INTEREST IN  
PROPERTY TO BE AFFECTED BY  
THE ISSUANCE OF THE BONDS  
AND LEVY OF ASSESSMENTS  
HEREIN DESCRIBED, OR TO  
BE AFFECTED IN ANY WAY  
THEREBY,  
Defendants.

TO THE STATE OF FLORIDA, AND  
THE TAXPAYERS, PROPERTY  
OWNERS AND CITIZENS  
OF VENICE GRAND OAKS  
COMMUNITY DEVELOPMENT  
DISTRICT, INCLUDING NON-  
RESIDENTS OWNING PROPERTY  
OR SUBJECT TO TAXATION  
THEREIN, AND OTHERS HAVING  
OR CLAIMING ANY RIGHT, TITLE  
OR INTEREST IN PROPERTY TO  
BE AFFECTED BY THE ISSUANCE  
OF VENICE GRAND OAKS  
COMMUNITY DEVELOPMENT  
DISTRICT SPECIAL ASSESSMENT  
BONDS, OR TO BE AFFECTED  
THEREBY:

The above cause comes to be heard  
upon the Complaint (DIN 2), filed here-  
in on May 14, 2026, by Venice Grand  
Oaks Community Development Dis-  
trict, a local unit of special-purpose gov-  
ernment established pursuant to Chap-  
ter 190, Florida Statutes, in the County  
of Sarasota, State of Florida, seeking to  
determine the authority of said District  
to issue Venice Grand Oaks Community  
Development District Special Assess-  
ment Bonds in an aggregate principal  
amount not to exceed \$17,560,000  
("Bonds"), to determine the legality of  
the proceedings had and taken in con-  
nection therewith, and the legality of  
the provisions, covenants and agree-  
ments therein contained, and seeking  
a judgment of this Court that: (a) the  
District has the power and authority  
under Chapter 190, Florida Statutes,  
and other applicable law to undertake  
the Capital Improvement Plan, to issue  
the Bonds and all series thereof and to  
incur the bonded debt as set forth in  
the Complaint, and to secure the Bonds  
with the Assessments; (b) the proceed-  
ings essential to the authorization and

issuance of the Bonds and all series  
thereof when issued pursuant thereto;  
the Pledged Revenues, including, with-  
out limitation, the Assessments pledged  
for the payment of the principal thereof,  
redemption premium, if any, and inter-  
est thereon; and the Bond Resolution  
are valid and in conformity with law;  
(c) the Assessments are supported by  
sufficient benefit, do not exceed the  
benefit received by the assessed prop-  
erties, and are fairly and reasonably al-  
located across all benefited properties  
in accordance with Chapter 170, Florida  
Statutes, and other applicable law;  
(d) upon due issuance of the Bonds in  
conformance with the Bond Resolution  
and the Indenture, the Bonds will con-  
stitute valid and binding special obliga-  
tions of the District payable solely from  
and secured by the Pledged Revenues  
and will be enforceable by their terms  
as established by the Bond Resolution  
and the Indenture; (e) the District has  
the power to plan, finance, acquire,  
construct, reconstruct, equip and in-  
stall, in one or more stages, the Cap-  
ital Improvement Plan; (f) the Capital  
Improvement Plan will serve a proper,  
essential and valid public purpose; (g)  
the members of the District's Board of  
Supervisors have been duly and validly  
elected or appointed in accordance with  
Chapter 190, Florida Statutes; and (h)  
this Court may grant such other relief  
as is just and appropriate. The aforesaid  
Complaint having been presented to  
this Court pursuant to Chapter 75, Flor-  
ida Statutes, and Section 190.016(9),  
Florida Statutes, and this Court being  
fully advised in the premises and having  
jurisdiction over the subject matter and  
the parties:

NOW, THEREFORE,

IT IS ORDERED that all taxpayers,  
property owners, and citizens of the  
District, including non-residents own-  
ing property or subject to taxation, and  
others having or claiming any right,  
title or interest in property to be af-  
fected by the issuance of the Bonds or  
to be affected thereby and the State of  
Florida, through the State Attorney of  
the Twelfth Judicial Circuit, in and for  
Sarasota County, Florida, are hereby  
required to appear on Tuesday, August  
4, 2026, at 9:00 a.m. for fifteen (15)  
minutes, before the Honorable Andrea  
Johnson, Circuit Court Judge, to show  
cause, if any there be, why the prayers  
of said Complaint for the validation of  
the Bonds and the Assessments should  
not be granted and the Bonds, the As-  
sessments, the proceedings therefor,  
and other matters set forth in said  
Complaint, should not be validated as  
prayed for in said Complaint.

PLEASE TAKE NOTICE that the  
Order and Show Cause Hearing will  
take place remotely via Zoom.

Zoom Credentials:  
[https://www.zoom.us/](https://www.zoom.us/Join)  
Click "Join A Meeting"  
Meeting ID: 353 234 4884  
Password: 756433

You must appear with a working  
camera; no telephone appearances.  
There are no fees for attending this

court hearing via the Zoom platform.  
Unless the Judge specifically authorizes  
an in-person attendance, all individu-  
als, including the court reporter, must  
attend using the Zoom platform at  
<https://www.zoom.us>. Please select the  
"Join A Meeting" link and then enter  
the Meeting ID and Password to access  
the hearing. You may also join the court  
hearing from Judge Carroll's Zoom  
Video Conference Access Information  
page at [https://www.jud12.flcourts.org/](https://www.jud12.flcourts.org/About-the-Court/Judges-Magistrates/Judge-Hunter-Carroll)  
About-the-Court/Judges-Magistrates/  
Judge-Hunter-Carroll.

Court proceedings are open to the  
public. Members of the public may use  
the Zoom credentials to access the hear-  
ing. Judge Johnson will "host" the vid-  
econference. When you sign on, you  
will be placed in a waiting room. The  
Court will admit you at the beginning  
of the hearing. Please name your video  
feed with your first and last name.

Alternatively, you may attend the  
hearing in person at the Judge Lynn N.  
Silvertooth Judicial Center, 2002 Ring-  
ling Boulevard, Sarasota, Florida 34237  
in Courtroom 6C.

IT IS FURTHER ORDERED that  
prior to the date set for the hearing  
on said Complaint for validation, the  
Clerk of this Court shall cause a copy  
of this Notice and Agreed Order to Show  
Cause to be published in a newspaper of  
general circulation published in Sara-  
sota County, Florida, being the County  
wherein said Complaint for validation  
is filed, at least once each week for  
two (2) consecutive weeks, with the  
first publication to occur not less than  
twenty (20) days prior to the date set  
for said hearing, all in accordance with  
the requirements of Section 75.06, Florida  
Statutes.

IT IS FURTHER ORDERED that by  
such publication of this Notice and Or-  
der, the State of Florida, and the several  
taxpayers, property owners and citizens  
of the District, including non-residents  
owning property or subject to taxation  
therein, and others having or claiming  
any rights, title or interest in property to  
be affected by the issuance of the Bonds  
or to be affected thereby, shall be and  
are made party defendants to this pro-  
ceeding, and that this Court shall have  
jurisdiction of them to the same extent  
as if specifically and personally named  
as defendants in said Complaint and  
personally served with process in this  
cause.

DONE AND ORDERED in Sarasota  
County, Florida.

Hunter W. Carroll,  
Circuit Court Judge  
Expectations for ALL Participants  
Attending Zoom Hearings

Please see the expectations for all  
participants on the Twelfth Judicial  
Court Website: [https://www.jud12.fl-](https://www.jud12.flcourts.org/Public-Information/Public-Court-Hearings)  
[courts.org/Public-Information/Public-](https://www.jud12.flcourts.org/Public-Information/Public-Court-Hearings)  
Court-Hearings.

Late entry or Technical Difficulties  
(Optional)

If you are not logged in when the  
hearing begins, the Judge may not in-  
terrupt the proceedings to admit you  
to the hearing. If you have trouble log-

ging in, and you wish to participate  
in the hearing, contact the Judge's Judicial  
Assistant immediately.

Digital Court Recording  
You are advised that the Court may  
record this proceeding via the Court's  
Digital Court Recording. Not all hear-  
ings are digitally recorded, however.

No Recording Proceedings (Op-  
tional)

By court rule and court order, you are  
not authorized to make your own audio  
or visual recording of a court proceed-  
ing. No one may take "screenshots" or  
other audio or visual depictions of a  
court proceeding. Recording a court  
proceeding is strictly prohibited unless  
approved by the Judge. If you violate  
these rules, you may be held in con-  
tempt of court. Members of the media  
must comply with rule 2.450 and ad-  
ministrative order 2020-23.2 regard-  
ing media coverage. Please contact the  
Court's Public Information Officer for  
further information.

ADA Notice

If you are a person with a disability  
who needs any accommodation in  
order to participate in this proceeding,  
you are entitled, at no cost to you, to  
the provision of certain assistance.  
Please contact the XXXXXXX  
County Jury Office, (insert address as  
required), at least seven (7) days before  
your scheduled court appearance,  
or immediately upon receiving this  
notification if the time before the  
scheduled appearance is less than  
seven (7) days; if you are hearing or  
voice impaired, call 711. Additional  
ADA information can be found on the  
Twelfth Circuit Court Website: [https://](https://www.jud12.flcourts.org/Services/ADA-Interpreters)  
[www.jud12.flcourts.org/Services/ADA-](https://www.jud12.flcourts.org/Services/ADA-Interpreters)  
Interpreters (Optional)

The Twelfth Judicial Circuit provides  
spoken language court interpreters  
to limited-English-proficient persons  
in accordance with Title VI of the  
Civil Rights Act of 1964, section  
90.606, Florida Statutes, and Rule  
2.560, Florida Rules of Judicial  
Administration. If you require the  
assistance of an interpreter, please  
submit your request to:

[https://www.jud12.flcourts.org/](https://www.jud12.flcourts.org/Programs/Court-Interpreters/Interpreter-Request)  
[Programs/Court-Interpreters/](https://www.jud12.flcourts.org/Programs/Court-Interpreters/Interpreter-Request)  
Interpreter-Request or please call 941-  
749-3659. Please submit your request  
as early as possible, requests made with  
less than 5 business days' notice may  
not be accommodated.

El Duodécimo Circuito Judicial  
provee intérpretes judiciales de la  
lengua hablada a personas con dominio  
limitado del inglés de acuerdo con el  
Título VI de la Ley de Derechos Civiles de  
1964, la sección 90.606, los Estatutos de  
la Florida y la Regla 2.560 de las Reglas  
de Administración Judicial de la Florida.  
Si requiere la ayuda de un intérprete, por  
favor envíe su solicitud a [https://www.](https://www.jud12.flcourts.org/Programs/Court-Interpreters/Interpreter-Request/lang)  
[jud12.flcourts.org/Programs/Court-](https://www.jud12.flcourts.org/Programs/Court-Interpreters/Interpreter-Request/lang)  
Interpreters/Interpreter-Request/lang/  
so llame al 941-749-3659. Por favor,  
envíe su solicitud lo antes posible, las  
solicitudes hechas con menos de 5 días  
hábilés no pueden ser garantizadas.  
June 26; July 3, 2026 26-01469S



**SAVE TIME**

**Email your Legal Notice**  
[legal@businessobserverfl.com](mailto:legal@businessobserverfl.com)  
**Deadline Wednesday at noon • Friday Publication**

SARASOTA • MANATEE  
HILLSBOROUGH • PASCO  
PINELLAS • POLK • LEE  
COLLIER • CHARLOTTE

FLORIDA'S NEWSPAPER FOR THE C-SUITE  
**Business Observer**  
LN20906L\_V19

# Q&A

## Who benefits from legal notices?

You do. Legal notices are required because a government body or corporation wants to take action that can affect individuals and the public at large.

When the government is about to change your life, or your property or assets are about to be taken, public notices in newspapers serve to alert those affected.

## Are there different types of legal notices?

Simply put, there are two basic types - Warning Notices and Accountability Notices.

Warning notices inform you when government, or a private party authorized by the government, is about to do something that may affect your life, liberty or pursuit of happiness. Warning notices typically are published more than once over a certain period.

Accountability notices are designed to make sure citizens know details about their government. These notices generally are published one time, and are archived for everyone to see. Accountability is key to efficiency in government.

## Are internet-only legal notices sufficient?

No. While the internet is clearly a useful resource, websites should not be used as the sole source of a legal notice.

Websites, whether controlled by a government body or a private firm, are not independent, archived, readily available or independently verified.

Newspaper legal notices fulfill all of those standards.

## How much do legal notices cost?

The price for notices in the printed newspaper must include all costs for publishing the ad in print, on the newspaper's website and to [www.floridapublicnotices.com](http://www.floridapublicnotices.com).

The public is well-served by notices published in a community newspaper.

**VIEW NOTICES ONLINE AT**  
[Legals.BusinessObserverFL.com](http://Legals.BusinessObserverFL.com)

To publish your legal notice Email:  
[legal@businessobserverfl.com](mailto:legal@businessobserverfl.com)

## SUBSEQUENT INSERTIONS

### --- PUBLIC SALES ---

#### SECOND INSERTION

##### NOTICE OF PUBLIC SALE

Extra Space Storage, on behalf of itself or its affiliates, Life Storage or Storage Express, will hold a public auction to sell personal property described below belonging to those individuals listed below at the location indicated:

Extra Space Storage, 2201 Fruitville Rd. Sarasota, FL 34237, 7/09/2026 10:00AM

JUAN MORALES

Household Goods/Furniture

The auction will be listed and advertised on [www.storage-treasures.com](http://www.storage-treasures.com). Purchases must be made with cash only and paid at the above referenced facility in order to complete the transaction. Extra Space Storage may refuse and bid and may rescind any purchase up until the winning bidder takes possession of the personal property. June 19, 26, 2026 26-01341S

#### SECOND INSERTION

##### NOTICE OF PUBLIC SALE

Notice is hereby given that on 07/10/2026, at 10:30 a.m., the following property will be sold at public auction pursuant to F.S. 715.109: A 1985 FRAN recreational vehicle bearing the vehicle identification number 10FBA02SOF1015562, and all personal items located inside the recreational vehicle. Last Tenant: John Leslie Hosford, All Unknown Beneficiaries, Heirs, Successors, Assigns, and Devisees of John Leslie Hosford, Unknown Party or Parties in Possession, Michael Eugene Hosford, as Potential Heir and Nicholas A. Hosford, as Potential Heir. Sale to be held at: Sun Outdoors Sarasota, 7125 Fruitville Road, Sarasota, Florida 34240, 941-371-2505. June 19, 26, 2026 26-01418S

#### SECOND INSERTION

##### NOTICE OF PUBLIC SALE

Extra Space Storage, on behalf of itself or its affiliates, Life Storage or Storage Express, will hold a public auction to sell personal property described below belonging to those individuals listed below at the location indicated:

19430 Times Cir  
Venice, FL 34292  
07/09/2026 at 11:00 AM

Francis Costello

Art work boxes

The auction will be listed and advertised on [www.storage-treasures.com](http://www.storage-treasures.com). Purchases must be made with cash only and paid at the above referenced facility in order to complete the transaction. Extra Space Storage may refuse any bid and may rescind any purchase up until the winning bidder takes possession of the personal property. June 19, 26, 2026 26-01338S

#### SECOND INSERTION

##### NOTICE OF PUBLIC SALE

Extra Space Storage, on behalf of itself or its affiliates, Life Storage or Storage Express, will hold a public auction to sell personal property described below belonging to those individuals listed below at the location indicated:

5005 Englewood Road, Venice, FL 34293 Date: 07/09/2026 Time: 10.30am

Grant Pogan

Household Goods

Brandie Bupp

Beach Chair, Beach Wagon, Beach Umbrella

The auction will be listed and advertised on [www.storage-treasures.com](http://www.storage-treasures.com). Purchases must be made with cash only and paid at the above referenced facility in order to complete the transaction. Extra Space Storage may refuse any bid and may rescind any purchase up until the winning bidder takes possession of the personal property. June 19, 26, 2026 26-01339S

#### FOURTH INSERTION

##### NOTICE OF ACTION IN THE COUNTY COURT OF THE 12TH JUDICIAL CIRCUIT IN AND FOR SARASOTA COUNTY, FLORIDA

Case No.: 2026 CC 001682 NC

**DIRECT GENERAL  
INSURANCE COMPANY,  
Plaintiff, v.  
GERSON MACHADO,  
ALCIONE DE SIQUEIRA, and  
PETER ROBERT THIBODEAU,  
Defendants.**

TO: PETER ROBERT THIBODEAU  
Address Unknown

YOU ARE NOTIFIED that Direct General Insurance Company has instituted an Action for Declaratory Judgment against you in the County Civil Court, in and for Sarasota County and you are required to serve a copy of your written defenses, if any, to it on McFARLANE LAW, whose address is 210 N. University Drive, 6th Floor, Coral

Springs, Florida 33071, and file the original with the Clerk of Court at Sarasota County Historic Courthouse, 2000 Main St., Sarasota, FL 34237 on or before July 6, 2026, either before service on Plaintiff's attorney or immediately thereafter; otherwise a default will be entered against you for the relief demanded in the Complaint for Declaratory Judgment.

This notice shall be published once each week for four consecutive weeks in The Business Observer.

Witness my hand and seal of this Court on this 28 day of May, 2026.

Karen E. Rushing  
As Clerk of the Court  
(SEAL)

By: Glen Kopinsky  
As Deputy Clerk

McFARLANE LAW,  
210 N. University Drive, 6th Floor,  
Coral Springs, Florida 33071  
June 5, 12, 19, 26, 2026 26-01225S

#### SECOND INSERTION

##### NOTICE OF PUBLIC SALE

Extra Space Storage will hold a public auction to sell personal property described below belonging to those individuals listed below at the location indicated:

Facility Address 8400 Fruitville Rd Sarasota FL 34240

Phone Number 941-263-3695

Time of Sale 07/09/2026 10:00am

Nicholas Hays- bed couch toys bikes

The auction will be listed and advertised on [www.storage-treasures.com](http://www.storage-treasures.com). Purchases must be made with cash only and paid at the above referenced facility in order to complete the transaction. Extra Space Storage may refuse any bid and may rescind any purchase up until the winning bidder takes possession of the personal property. June 19, 26, 2026 26-01342S

#### SECOND INSERTION

##### NOTICE OF PUBLIC SALE

Extra Space Storage, on behalf of itself or its affiliates, Life Storage or Storage Express, will hold a public auction to sell personal property described below belonging to those individuals listed below at the location indicated:

Extra Space Storage

2255 N. Washington Blvd.

Sarasota, FL. 34234

Auction 07/09/2026 at 10:00 AM

-Asia Odom

2br apartment furnishings

-Shameka Haygood

Party supplies

-Timothy Kelly

Clothesbasket- 3-4 boxes -diapers in

boxes- no furniture - small appliances -

bags -books - kitchen

The auction will be listed and advertised on [www.storage-treasures.com](http://www.storage-treasures.com). Purchases must be made with cash only and paid at the above referenced facility in order to complete the transaction. Extra Space Storage may refuse any bid and may rescind any purchase up until the winning bidder takes possession of the personal property. June 19, 26, 2026 26-01349S

#### SECOND INSERTION

##### NOTICE OF PUBLIC SALE

Extra Space Storage, on behalf of itself or its affiliates, Life Storage or Storage Express, will hold a public auction to sell personal property described below belonging to those individuals listed below at the location indicated:

4029 Bee Ridge Road Sarasota, FL

34233, on 07/09/2026 at 10:00am

Gary Wilke

-Household Goods/Furniture

Allias Harrison

-Dirtbikes, powerwheels, parts, bumpers, wheels, tires.

Jennifer Rottger

-Boxes, Household Items

Brett Thomas

-Yard Stuff, Furniture

The auction will be listed and advertised on [www.storage-treasures.com](http://www.storage-treasures.com).

Purchases must be made with cash only and paid at the above referenced facility in order to complete the transaction.

Extra Space Storage may refuse any bid and may rescind any purchase up until the winning bidder takes possession of the personal property.

June 19, 26, 2026 26-01343S

#### SECOND INSERTION

##### NOTICE OF PUBLIC SALE

Pursuant to the Florida Self Storage Lien Act, the owner of a self-storage facility has a lien upon all personal property located at the self-service storage facility for rent or other charges incurred for the storage of the personal property. Due to the failure to pay the rent, the owner is enforcing its lien and intends to sell or otherwise dispose of the personal property located in the rented spaces listed in this notice. THIS NOTICE IS BEING PROVIDED PURSUANT TO FLORIDA STATE LAW BEFORE the sale; the tenants listed may pay the amount necessary to satisfy the lien and the reasonable expenses incurred to redeem the personal property. ADVERTISEMENT OF SALE: Notice is hereby given that the personal property located in the following storage units will be sold by competitive bidding.

Bidding: All bidding will take place online at [StorageTreasures.com](http://StorageTreasures.com) on July 10, 2026, at 11:00 AM EST. Property will be sold to the highest bidder.

**7002 - 335 South Beneva Rd, Sarasota, FL 34233 - 941-732-1753:** Shane Eagan- Boxes, Tool Boxes, Wooden Shelf, Shop Vac, Portable Pressure Washer, Totes, Crystal Glasses, Metal Industrial Shelf, Bucket with Tie Downs, Pill Box; Holly Bright- Wall Art, Cleaning Supplies, Suitcases, Lamps, Totes, Boxes, Crock Pots, Immersion Blender, Cooler, Shoes, Water, Area Rug, Kitchen Bowls;

**7101 -7600 Claxtrauss Dr, Sarasota, FL 34240 - 941-213-5391:** David assip- Holiday Decorations Signs, Spools of Holiday Light wires & Fixtures, Large Plastic Totes, Holiday Lights, Plastic Tote Lids.

**7005 - 2590 17th St., Sarasota, FL 34234 - 941-842-0532:** Hunter Null- Brunle- Ryobi Pressure Washer, Shoes/Sneakers, Food, Box, Backpack, Blanket, Bags; Asia Lamb- Clothes, Full Mattress, Bags, Plastic Storage Rack, Tote, Books, DVD Rack and DVD's, TV Stand w/TV Bracket, Vaporizer, Foot Massager, Dumb Bell, Rack, Garbage Pail, Kids Stuffed Animals, Shoes, Exercise Step, Storage Units, Tennis Racket, Boxes; Robert Kirkwood- Two Tool Boxes, Sneakers, Seat; Stephen Hixon- 25 Gal Mobile Tool Box, Sack, Multiple Luggage, Clothes, Shoes, ASST Hats, Beauty Supplies, Bags, Duffle Bag, Cart, Hard Hat; Natalie Mays- Lg Flat Screen TV, Clothes, Laundry Baskets, Back Pack, Luggage, Bags, Comforter, Pillows, Kids Walker, Kids Clothes. June 19, 26, 2026 26-01398S

# SAVE TIME



Email your Legal Notice

[legal@businessobserverfl.com](mailto:legal@businessobserverfl.com) • Deadline Wednesday at noon • Friday Publication

SARASOTA • MANATEE • HILLSBOROUGH • PASCO  
PINELLAS • POLK • LEE • COLLIER • CHARLOTTE

FLORIDA'S NEWSPAPER FOR THE G-SUITE  
**Business  
Observer**

--- PUBLIC SALES / ESTATE ---

SECOND INSERTION

**NOTICE OF TRUST**  
IN THE CIRCUIT COURT OF THE TWELFTH JUDICIAL CIRCUIT IN AND FOR SARASOTA COUNTY, FLORIDA CIVIL DIVISION PROBATE DIVISION  
**File No. 2026 - CP 3329**  
**IN RE: ESTATE OF SABINA ZOLTE, Deceased.**

SABINA ZOLTE, a resident of Sarasota County, Florida, who died on 30TH DAY OF APRIL, 2026 was the grantor of a trust entitled: SABINA ZOLTE REVOCABLE TRUST UNDER AGREEMENT DATED THE 16TH DAY OF JUNE, 2017, which is a trust described in Section 733.707(3) of the Florida Probate Code, and is liable for the expenses of the administration of the decedent's estate and enforceable

claims of the decedent's creditors to the extent the decedent's estate is insufficient to pay them, as provided in Section 733.607(2) of the Florida Probate Code. Additionally, this Notice of Trust is provide under Section 736.0604 of the Florida Statutes regarding a limitation on an action contesting the validity of this Revocable Trust and any amendments thereto and will be barred unless action is taken within the statutory time frame.

The name of the trustee and the name and address of his counsel are set forth below.

The Clerk shall file and index this notice of trust in the same manner as a caveat. Unless there exists a probate proceeding for the grantor's estate in which case this notice of trust must be filed in the probate proceeding and the

clerk shall send a copy to the personal representative.

Dated this 10 day of June, 2026.  
**ABIGAIL LIEBERMAN, Successor Trustee of the SABINA ZOLTE REVOCABLE TRUST UNDER AGREEMENT DATED THE 16TH DAY OF JUNE, 2017**  
Address: 311 Oakdale Ave  
Corte Madera CA 94925

Andrew W. Rosin, Esq.  
Law Office of Andrew W. Rosin, P.A.  
1966 Hillview Street  
Sarasota, FL 34239  
(941) 359-2604  
(941) 366-1252 facsimile  
Attorney for Successor Trustee  
arosin@rosinlawfirm.com  
June 19, 26, 2026 26-01402S

SECOND INSERTION

**NOTICE OF PUBLIC SALE**  
Extra Space Storage, on behalf of itself or its affiliates, Life Storage or Storage Express, will hold a public auction to sell personal property described below belonging to those individuals listed below at the location indicated:  
757 Apex Road Sarasota, Florida 34240 on 07/13/2026 at 10:00 am  
Evan Chouinard  
quad 13 foot kayak tools  
The auction will be listed and advertised on www.storagetreasures.com. Purchases must be made with cash only and paid at the above referenced facility in order to complete the transaction. Extra Space Storage may refuse any bid and may rescind any purchase up until the winning bidder takes possession of the personal property.  
June 19, 26, 2026 26-01372S

SECOND INSERTION

**NOTICE OF PUBLIC SALE**  
Extra Space Storage, on behalf of itself or its affiliates, Life Storage or Storage Express, will hold a public auction to sell personal property described below belonging to those individuals listed below at the location indicated:  
5005 Englewood Road, Venice, FL 34293 Date: 07/09/2026 Time: 10.30am  
Nancy Shoupe household items  
James Conway  
2013 Toyota Prius running  
Tnayo Turner  
Tools hand battery saws air compressor  
Elevay MCG  
Tools hand battery saws air compressor  
The auction will be listed and advertised on www.storagetreasures.com. Purchases must be made with cash only and paid at the above referenced facility in order to complete the transaction. Extra Space Storage may refuse any bid and may rescind any purchase up until the winning bidder takes possession of the personal property.  
June 19, 26, 2026 26-01340S

SECOND INSERTION

**NOTICE TO CREDITORS**  
IN THE CIRCUIT COURT FOR SARASOTA COUNTY, FLORIDA PROBATE DIVISION  
**File No. 2026-CP-002079-NC**  
**IN RE: ESTATE OF: NANCY R. BRADTMILLER, Deceased.**

The administration of the estate of NANCY R. BRADTMILLER, deceased, whose date of death was February 13, 2026; is pending in the Circuit Court for Sarasota County, Florida, Probate Division, the address of which is 2000 Main Street, Sarasota, Florida 34236. The names and addresses of the personal representative and the personal representative's attorney are set forth below.

All creditors of the decedent and other persons having claims or demands against decedent's estate, on whom a copy of this notice is required to be served must file their claims with this court ON OR BEFORE THE LATER OF 3 MONTHS AFTER THE TIME OF THE FIRST PUBLICATION OF THIS NOTICE OR 30 DAYS AFTER THE DATE OF SERVICE OF A COPY OF THIS NOTICE ON THEM.

All other creditors of the decedent and other persons having claims or de-

mands against decedent's estate must file their claims with this court WITHIN 3 MONTHS AFTER THE DATE OF THE FIRST PUBLICATION OF THIS NOTICE.

ALL CLAIMS NOT FILED WITHIN THE TIME PERIODS SET FORTH IN FLORIDA STATUTES SECTION 733.702 WILL BE FOREVER BARRED.

NOTWITHSTANDING THE TIME PERIOD SET FORTH ABOVE, ANY CLAIM FILED TWO (2) YEARS OR MORE AFTER THE DECEDENT'S DATE OF DEATH IS BARRED.

The date of first publication of this notice is: June 19, 2026.

**Stuart C. McCracken, Personal Representative**  
930 Pinkney Place  
Stanley, North Carolina 28164  
Dave M. Evans, Jr.  
Attorney for Personal Representative  
Email: DEvans@leeandevans.com  
Secondary Email:  
SKrauss@leeandevans.com  
Florida Bar No. 1013511  
Lee & Evans, P.A.  
2601 Cattlemen Road, Suite 503  
Sarasota, Florida 34232  
Telephone: 941-954-0067  
June 19, 26, 2026 26-01335S

SECOND INSERTION

**NOTICE TO CREDITORS**  
IN THE CIRCUIT COURT OF THE 12th JUDICIAL CIRCUIT, IN AND FOR SARASOTA COUNTY, FLORIDA PROBATE DIVISION  
**File No. 2026 CP 002868 SC**  
**IN RE: ESTATE OF COLLEEN M. FOGARTY Deceased.**

The administration of the estate of COLLEEN M. FOGARTY, deceased, whose date of death was November 22, 2025, is pending in the Circuit Court for Sarasota County, Florida, Probate Division; File Number 2026 CP 002868 SC; the address of which is 2000 Main St, Sarasota, FL 34237. The names and addresses of the Petitioner and the Petitioner's attorney are set forth below.

All creditors of the decedent and other persons, who have claims or demands against decedent's estate, including unmatue, contingent or unliquidated claims, and who have been served a copy of this notice, must file their claims with this court WITHIN THE LATER OF THREE (3) MONTHS AFTER THE DATE OF THE FIRST PUBLICATION OF THIS NOTICE OR THIRY (30) DAYS AFTER THE DATE OF SERVICE OF A COPY OF THIS

SECOND INSERTION

**NOTICE ON THEM.**

All other creditors of the decedent and other persons who have claims or demands against the decedent's estate, including unmatue, contingent or unliquidated claims, must file their claims with this court WITHIN THREE (3) MONTHS AFTER THE DATE OF THE FIRST PUBLICATION OF THIS NOTICE.

ALL CLAIMS NOT SO FILED WILL BE FOREVER BARRED.

NOTWITHSTANDING THE TIME PERIODS SET FORTH ABOVE, ANY CLAIM FILED TWO (2) YEARS OR MORE AFTER THE DECEDENT'S DATE OF DEATH IS BARRED.

THE DATE OF FIRST PUBLICATION OF THIS NOTICE IS June 19, 2026.

**Petitioner Morgan Vega**  
1253 Pavo Path,  
Wendell, NC 275911  
Attorney for Petitioner  
s/ Harry C. Palmer III, Esq.  
Florida Bar No. 260975  
Harry C. Palmer III, Esq.  
PO BOX 330232,  
Miami, FL 33233  
Phone: 305-445-2424  
June 19, 26, 2026 26-01380S

SECOND INSERTION

**NOTICE TO CREDITORS**  
IN THE TWELFTH JUDICIAL CIRCUIT COURT IN AND FOR SARASOTA COUNTY, FLORIDA PROBATE DIVISION  
**Case No.: 2026 CP 001176 SC**  
**IN RE: ESTATE OF RICHARD HUGH COOK**

The administration of the estate of RICHARD HUGH COOK, deceased, whose date of death was December 14, 2025, is pending in the Circuit Court for SARASOTA County, Florida, Probate Division, the address of which is . The names and addresses of the personal representative and the personal representative's attorney are set forth below.

All creditors of the decedent and other persons having claims or demands against decedent's estate on whom a copy of this notice is required to be served must file their claims with this court ON OR BEFORE THE LATER OF 3 MONTHS AFTER THE TIME OF THE FIRST PUBLICATION OF THIS NOTICE OR 30 DAYS AFTER THE DATE OF SERVICE OF A COPY OF THIS NOTICE ON THEM.

All other creditors of the decedent and other persons having claims or demands against decedent's estate must

file their claims with this court WITHIN 3 MONTHS AFTER THE DATE OF THE FIRST PUBLICATION OF THIS NOTICE.

ALL CLAIMS NOT FILED WITHIN THE TIME PERIODS SET FORTH IN FLORIDA STATUTES SECTION 733.702 WILL BE FOREVER BARRED.

NOTWITHSTANDING THE TIME PERIODS SET FORTH ABOVE, ANY CLAIM FILED TWO (2) YEARS OR MORE AFTER THE DECEDENT'S DATE OF DEATH IS BARRED.

The date of first publication of this notice is June 19, 2026.

**Personal Representative: MATTHEW J. MATECHIK, ESQ.**  
Attorney for Personal Representative: MATTHEW J. MATECHIK, ESQ.  
Florida Bar Number: 126342  
The Matchik Law Firm, P.A.  
100 Wallace Avenue, Suite 310  
Sarasota, FL 34237  
Telephone: (941) 926-6755  
Fax: (941) 244-5679  
E-Mail: matt@thematchiklawfirm.com  
Sec. E-Mail: jill@thematchiklawfirm.com  
June 19, 26, 2026 26-01357S

SECOND INSERTION

**NOTICE TO CREDITORS**  
IN THE CIRCUIT COURT FOR SARASOTA COUNTY, FLORIDA PROBATE DIVISION  
**File No. 2026-CP-002683-NC**  
**Division Probate**  
**IN RE: ESTATE OF ANTHONY S. LEFCO, Deceased.**

The administration of the estate of Anthony S. Lefco, deceased, whose date of death was March 7, 2026, is pending in the Circuit Court for Sarasota County, Florida, Probate Division, the address of which is P.O. Box 3079, Sarasota, FL 34230. The names and addresses of the personal representative and the personal representative's attorney are set forth below.

All creditors of the decedent and other persons having claims or demands against decedent's estate on whom a copy of this notice is required to be served must file their claims with this court ON OR BEFORE THE LATER OF 3 MONTHS AFTER THE TIME OF THE FIRST PUBLICATION OF THIS NOTICE OR 30 DAYS AFTER THE DATE OF SERVICE OF A COPY OF THIS NOTICE ON THEM.

All other creditors of the decedent and other persons having claims or demands against decedent's estate must file their claims with this court WITHIN 3 MONTHS AFTER THE DATE OF THE FIRST PUBLICATION OF THIS NOTICE.

The personal representative has no

duty to discover whether any property held at the time of the decedent's death by the decedent or the decedent's surviving spouse is property to which the Florida Uniform Disposition of Community Property Rights at Death Act as described in ss. 732.216-732.228, applies, or may apply, unless a written demand is made by a creditor as specified under s. 732.2211, Florida Statutes. The written demand must be filed with the clerk.

ALL CLAIMS NOT FILED WITHIN THE TIME PERIODS SET FORTH IN FLORIDA STATUTES SECTION 733.702 WILL BE FOREVER BARRED.

NOTWITHSTANDING THE TIME PERIOD SET FORTH ABOVE, ANY CLAIM FILED TWO (2) YEARS OR MORE AFTER THE DECEDENT'S DATE OF DEATH IS BARRED.

The date of first publication of this notice is June 19, 2026.

**Personal Representative: Randall Sample**  
3161 Campbell Street  
Sarasota, FL 34231  
Attorney for Personal Representative: Charla M. Burchett  
E-Mail Addresses: cburchett@shutts.com cmbcourt@shutts.com  
Florida Bar No. 0813230  
Shutts & Bowen LLP  
1858 Ringling Blvd., Suite 300  
Sarasota, FL 34236  
Telephone: (941) 552-3500  
June 19, 26, 2026 26-01407S

SECOND INSERTION

**NOTICE TO CREDITORS**  
IN THE CIRCUIT COURT FOR SARASOTA COUNTY, FLORIDA PROBATE DIVISION  
**File No. 2026-CP-003253 SC**  
**IN RE: ESTATE OF BEVERLY ALRENE HOWARD Deceased.**

The administration of the estate of Beverly Alrene Howard, deceased, whose date of death was July 14, 2025, is pending in the Circuit Court for SARASOTA County, Florida, Probate Division, the address of which is 200 Main Street, Room 102, Sarasota, FL 34237. The names and addresses of the personal representative and the personal representative's attorney are set forth below.

All creditors of the decedent and other persons having claims or demands against decedent's estate on whom a copy of this notice is required to be served must file their claims with this court ON OR BEFORE THE LATER OF 3 MONTHS AFTER THE TIME OF THE FIRST PUBLICATION OF THIS NOTICE OR 30 DAYS AFTER THE DATE OF SERVICE OF A COPY OF THIS NOTICE ON THEM.

All other creditors of the decedent and other persons having claims or demands against decedent's estate must file their claims with this court WITHIN 3 MONTHS AFTER THE DATE OF THE FIRST PUBLICATION OF THIS NOTICE.

The personal representative has no duty to discover whether any property held at the time of the decedent's death

SECOND INSERTION

by the decedent or the decedent's surviving spouse is property to which the Florida Uniform Disposition of Community Property Rights at Death Act as described in ss. 732.216-732.228, Florida Statutes, applies, or may apply, unless a written demand is made by a creditor as specified under s. 732.2211, Florida Statutes. The written demand must be filed with the clerk.

ALL CLAIMS NOT FILED WITHIN THE TIME PERIODS SET FORTH IN FLORIDA STATUTES SECTION 733.702 WILL BE FOREVER BARRED.

NOTWITHSTANDING THE TIME PERIODS SET FORTH ABOVE, ANY CLAIM FILED TWO (2) YEARS OR MORE AFTER THE DECEDENT'S DATE OF DEATH IS BARRED.

The date of first publication of this notice is June 19, 2026.

**Personal Representative: Kevin R. Barton**  
708 Meridian Ct.  
Concord, North Carolina 28025  
Attorney for Personal Representative: /s/ Andrej Cuturic  
Andrej Cuturic  
Attorney  
Florida Bar Number: 1018523  
801 E Venice Ave, Ste. 2  
Venice, Florida 34285  
Telephone: (941) 441-9193  
Fax: (941) 214-2629  
E-Mail: ac@legacylifelegal.com  
Secondary E-Mail: stephanie@legacylifelegal.com  
June 19, 26, 2026 26-01401S

SECOND INSERTION

**NOTICE TO CREDITORS**  
IN THE CIRCUIT COURT FOR SARASOTA COUNTY, FLORIDA PROBATE DIVISION  
**File No. 2026 CP 003194**  
**IN RE: ESTATE OF Cynthia Lynn Blackmon Deceased.**

The administration of the estate of Cynthia Lynn Blackmon, deceased, whose date of death was April 13th, 2026, is pending in the Circuit Court for Sarasota County, Florida, Probate Division, the address of which is 2000 Main Street, Sarasota, Florida 34239. The names and addresses of the personal representative and the personal representative's attorney are set forth below.

All creditors of the decedent and other persons having claims or demands against decedent's estate on whom a copy of this notice is required to be served must file their claims with this court ON OR BEFORE THE LATER OF 3 MONTHS AFTER THE TIME OF THE FIRST PUBLICATION OF THIS NOTICE OR 30 DAYS AFTER THE DATE OF SERVICE OF A COPY OF THIS NOTICE ON THEM.

All other creditors of the decedent and other persons having claims or demands against decedent's estate must file their claims with this court WITHIN 3 MONTHS AFTER THE DATE OF THE FIRST PUBLICATION OF THIS NOTICE.

The personal representative has no duty to discover whether any property held at the time of the decedent's death by the decedent or the decedent's surviving spouse is property to which the Florida Uniform Disposition of Community Property Rights at Death Act as described in ss. 732.216-732.228, applies, or may apply, unless a written demand is made by a creditor as specified under s. 732.2211, Florida Statutes.

ALL CLAIMS NOT FILED WITHIN THE TIME PERIODS SET FORTH IN FLORIDA STATUTES SECTION 733.702 WILL BE FOREVER BARRED.

NOTWITHSTANDING THE TIME PERIODS SET FORTH ABOVE, ANY CLAIM FILED TWO (2) YEARS OR MORE AFTER THE DECEDENT'S DATE OF DEATH IS BARRED.

The date of first publication of this notice is June 19, 2026.

**/S/Eric H. Blackmon**  
P.O. Address:  
2249 Palm Terrace,  
Sarasota, FL 34231  
**Personal Representative**  
ANDREW W. ROSIN, P.A.  
Attorneys for Personal Representative  
1966 HILLVIEW STREET  
SARASOTA, FL 34239  
Telephone: (941) 359-2604  
Florida Bar No. 0598305  
Email Addresses:  
arosin@rosinlawfirm.com  
June 19, 26, 2026 26-01351S

SECOND INSERTION

**NOTICE TO CREDITORS (Summary Administration)**  
IN THE CIRCUIT COURT FOR SARASOTA COUNTY, FLORIDA PROBATE DIVISION  
**File No. 2026-CP-1246-NC**  
**IN RE: ESTATE OF: JAMES H. REIGHART Deceased.**

TO ALL PERSONS HAVING CLAIMS OR DEMANDS AGAINST THE ABOVE ESTATE:

You are hereby notified that an Order of Summary Administration has been entered in the estate of JAMES H. REIGHART, deceased, File Number 2026-CP-1246-NC, by the Circuit Court for Sarasota County, Florida, Probate Division, the address of which is 2000 Main Street, Sarasota, Florida 34237; that the decedent's date of death was November 29, 2025; that the total value of the estate is \$0.00, and that

ALL INTERESTED PERSONS ARE NOTIFIED THAT:

All creditors of the estate of the decedent and persons having claims or demands against the estate of the decedent other than those for whom provision for full payment was made in the Order of Summary Administration must file their claims with this court WITHIN THE TIME PERIODS SET FORTH IN FLORIDA STATUTES SECTION 733.702. ALL CLAIMS AND DEMANDS NOT SO FILED WILL BE FOREVER BARRED. NOTWITHSTANDING ANY OTHER APPLI-

CABLE TIME PERIOD, ANY CLAIM FILED TWO (2) YEARS OR MORE AFTER THE DECEDENT'S DATE OF DEATH IS BARRED.

The personal representative has no duty to discover whether any property held at the time of the decedent's death by the decedent or the decedent's surviving spouse is property to which the Florida Uniform Disposition of Community Property Rights at Death Act as described in sections 732.216-732.288 Florida Statutes, applies, or may apply, unless a written demand is made by a creditor as specified under section 732.2211, Florida Statutes. The written demand must be filed with the clerk.

The date of first publication of this notice is June 19, 2026.

**Person Giving Notice: DOUGLAS S. REIGHART**  
7210 Brighton Park Court  
Chagrin Falls, Ohio 44023  
Attorney for Person Giving Notice /s/ Kyle T. Mordeew  
DANA MARIE DECAPITE, ESQ.  
Florida Bar Number: 100531  
KYLE T. MORDEEW, ESQ.  
Florida Bar Number: 1022234  
HAHN LOESER & PARKS LLP  
5811 Pelican Bay Boulevard, Suite 650  
Naples, Florida 34108  
Telephone: (239) 254-2900  
Fax: (239) 592-7716  
E-Mail: kmordeew@hahnlaw.com  
Secondary E-Mail: dlegan@hahnlaw.com  
June 19, 26, 2026 26-01355S

SECOND INSERTION

**NOTICE TO CREDITORS**  
IN THE CIRCUIT COURT FOR SARASOTA COUNTY, FLORIDA PROBATE DIVISION  
**File No. 2026 CP 003007**  
**Division PROBATE**  
**IN RE: ESTATE OF Lou Ann Branan, Deceased.**

The administration of the estate of Lou Ann Branan, deceased, whose date of death was October 21st, 2025, is pending in the Circuit Court for Sarasota County, Florida, Probate Division, the address of which is P.O. Box 3079, Sarasota, FL 34230. The names and addresses of the personal representatives and the personal representative's attorney are set forth below.

All creditors of the decedent and other persons having claims or demands against decedent's estate on whom a copy of this notice is required to be served must file their claims with this court ON OR BEFORE THE LATER OF 3 MONTHS AFTER THE TIME OF THE FIRST PUBLICATION OF THIS NOTICE OR 30 DAYS AFTER THE DATE OF SERVICE OF A COPY OF THIS NOTICE ON THEM.

All other creditors of the decedent and other persons having claims or demands against decedent's estate must file their claims with this court WITHIN 3 MONTHS AFTER THE DATE OF THE FIRST PUBLICATION OF THIS NOTICE.

The personal representative has no

SECOND INSERTION

duty to discover whether any property held at the time of the decedent's death by the decedent or the decedent's surviving spouse is property to which the Florida Uniform Disposition of Community Property Rights at Death Act as described in ss. 732.216-732.228, applies, or may apply, unless a written demand is made by a creditor as specified under s. 732.2211, Florida Statutes. The written demand must be filed with the clerk.

ALL CLAIMS NOT FILED WITHIN THE TIME PERIODS SET FORTH IN FLORIDA STATUTES SECTION 733.702 WILL BE FOREVER BARRED.

NOTWITHSTANDING THE TIME PERIODS SET FORTH ABOVE, ANY CLAIM FILED TWO (2) YEARS OR MORE AFTER THE DECEDENT'S DATE OF DEATH IS BARRED.

The date of first publication of this notice is 6/19/2026

**Carl K. Branan**  
27 Dominica Drive,  
Englewood, FL 34223  
**Personal Representative**  
Comprehensive Estate Planning, PLLC  
Attorneys for Personal Representative  
2477 Stickney Point Road  
Suite 215 B  
Sarasota, FL 34231  
Telephone: (941) 953-9600  
Florida Bar No. 987026  
Email Addresses:  
jwest@johnwestii.com  
June 19, 26, 2026 26-01381S

SECOND INSERTION

**NOTICE TO CREDITORS**  
IN THE CIRCUIT COURT FOR SARASOTA COUNTY, FLORIDA PROBATE DIVISION  
**File No. 2026 CP 002958 SC**  
**Division PROBATE**  
**IN RE: ESTATE OF ARLENE MORRIS A/K/A ARLENE T. MORRIS Deceased.**

The administration of the estate of ARLENE MORRIS A/K/A ARLENE T. MORRIS, deceased, whose date of death was December 7, 2025, is pending in the Circuit Court for Sarasota County, Florida, Probate Division, the address of which is 4004 S. Tamiami Trail, Venice, FL 34293. The names and addresses of the personal representative and the personal representative's attorney are set forth below.

All creditors of the decedent and other persons having claims or demands against decedent's estate on whom a copy of this notice is required to be served must file their claims with this court ON OR BEFORE THE LATER OF 3 MONTHS AFTER THE TIME OF THE FIRST PUBLICATION OF THIS NOTICE OR 30 DAYS AFTER THE DATE OF SERVICE OF A COPY OF THIS NOTICE ON THEM.

All other creditors of the decedent and other persons having claims or demands against decedent's estate must file their claims with this court WITHIN 3 MONTHS AFTER THE DATE OF THE FIRST PUBLICATION OF THIS NOTICE.

The personal representative has no duty to discover whether any property held at the time of the decedent's death

by the decedent or the decedent's surviving spouse is property to which the Florida Uniform Disposition of Community Property Rights at Death Act as described in ss. 732.216-732.228, Florida Statutes, applies, or may apply, unless a written demand is made by a creditor as specified under s. 732.2211, Florida Statutes. The written demand must be filed with the clerk.

ALL CLAIMS NOT FILED WITHIN THE TIME PERIODS SET FORTH IN FLORIDA STATUTES SECTION 733.702 WILL BE FOREVER BARRED.

NOTWITHSTANDING THE TIME PERIODS SET FORTH ABOVE, ANY CLAIM FILED TWO (2) YEARS OR MORE AFTER THE DECEDENT'S DATE OF DEATH IS BARRED.

The date of first publication of this notice is June 19, 2026.

**Personal Representatives: JOAN DALTO**  
1249 Vermeer Drive  
Nokomis, FL 34275  
**CATHLEEN MORRIS**  
232 Livorno Way  
Nokomis, FL 34275  
Attorney for Personal Representatives: FEDERICO MOJICA, ESQUIRE  
Attorney for Personal Representatives  
Florida Bar Number: 0124187  
Ross & Mojica Law Group  
871 Venetia Bay Blvd., Ste. 300B  
Venice, FL 34285  
Telephone: (941) 480-1948  
Fax: (941) 480-9277  
E-Mail: federico@rossmojicalaw.com  
Secondary E-Mail: shawn@rossmojicalaw.com  
June 19, 26, 2026 26-01409S

--- ACTIONS / SALES / ESTATE / PUBLIC SALES ---

## FOURTH INSERTION

**NOTICE OF ACTION – CONSTRUCTIVE SERVICE NOTICE OF ACTION**  
IN THE COUNTY COURT OF THE TWELFTH JUDICIAL CIRCUIT IN AND FOR SARASOTA COUNTY, FLORIDA  
**CASE NO.: 2026SC2129NC**  
**JASON MORTON,**  
Plaintiff, v.  
**MUNGER INTELLECT LLC / TRISTEN LARSEN,**  
Defendant.  
TO: Munger Intellect LLC / Tristen Larsen  
6517 Aberdour Circle  
Windsor, CO 80550

YOU ARE NOTIFIED that an action has been filed against you for damages for non-performance of contracted services in the amount of \$725.00 plus court costs, and you are required to serve a copy of your written defenses, if any, to Jason Morton, 5730 Clark Rd, Sarasota, FL 34233, on or before 20 days after the final publication date

of this Notice. If you fail to do so, a default may be entered against you for the relief demanded in the Statement of Claim.

If you are a person with a disability who needs any accommodation in order to participate in this proceeding, you are entitled, at no cost to you, to the provision of certain assistance. Please contact the Sarasota County Jury Office, P.O. Box 3079, Sarasota, Florida 34230-3079, (941)861-7400, at least seven (7) days before your scheduled court appearance, or immediately upon receiving this notification if the time before the scheduled appearance is less than seven (7) days; if you are hearing or voice impaired, call 711.

DATED on: March 05, 2026.

KAREN E. RUSHING,  
Clerk of the Circuit Court &  
County Comptroller  
Sarasota County, Florida  
By: K LEGASP, Deputy Clerk  
June 5, 12, 19, 26, 2026 26-01278S

## SECOND INSERTION

**NOTICE TO CREDITORS**  
IN THE CIRCUIT COURT FOR SARASOTA COUNTY, FLORIDA  
PROBATE DIVISION  
**CASE NO. 2026 003036 NC**  
IN RE: ESTATE OF  
**MICHAEL NORMAN BERGER,**  
a/k/a MICHAEL BERGER, a/k/a  
**MICHAEL N. BERGER,**  
Deceased.

The administration of the ESTATE OF MICHAEL NORMAN BERGER, a/k/a MICHAEL BERGER, a/k/a MICHAEL N. BERGER, also known, deceased, whose date of death was March 11, 2026, is pending in the Circuit Court for Sarasota County, Florida, Probate Division, the address of which is P.O. Box 3079, Sarasota, Florida 34230. The names and addresses of the personal representative and the personal representative's attorney are set forth below.

All creditors of the decedent and other persons having claims or demands against decedent's estate on whom a copy of this notice is required to be served must file their claims with this court ON OR BEFORE THE LATER OF 3 MONTHS AFTER THE TIME OF THE FIRST PUBLICATION OF THIS NOTICE OR 30 DAYS AFTER THE DATE OF SERVICE OF A COPY OF THIS NOTICE ON THEM.

All other creditors of the decedent and other persons having claims or demands against decedent's estate must file their claims with this court WITHIN 3 MONTHS AFTER THE DATE OF THE FIRST PUBLICATION OF THIS NOTICE.

ALL CLAIMS NOT FILED WITHIN

THE TIME PERIODS SET FORTH IN FLORIDA STATUTES SECTION 733.702 WILL BE FOREVER BARRED.

NOTWITHSTANDING THE TIME PERIODS SET FORTH ABOVE, ANY CLAIM FILED TWO (2) YEARS OR MORE AFTER THE DECEDENT'S DATE OF DEATH IS BARRED.

The personal representative has no duty to discover whether any property held at the time of the decedent's death by the decedent or the decedent's surviving spouse is property to which the Florida Uniform Disposition of Community Property Rights at Death Act as described in sections 732.216-732.228, Florida Statutes, applies, or may apply, unless a written demand is made by a creditor as specified under section 732.221, Florida Statutes. The written demand must be filed with the clerk.

The date of the first publication of this Notice is June 19, 2026.

**Personal Representative:**  
**CARMEN BASKIND**  
c/o 1217 S. Tamiami Trail  
Sarasota, Florida 34239  
Attorney for Personal Representative:  
/S/ J. ALLISON ARCHBOLD  
J. ALLISON ARCHBOLD  
Florida Bar Number: 115088  
Archbold Law Firm, P.A.  
1217 S. Tamiami Trail  
Sarasota, FL 34239  
Telephone: (941) 960-8825  
Fax: (941) 313-8456  
Primary Email: jaa@archbold.law  
Secondary Email:  
service@archbold.law  
June 19, 26, 2026 26-01415S

## FOURTH INSERTION

**NOTICE OF ACTION**  
IN THE CIRCUIT COURT OF THE TWELFTH JUDICIAL CIRCUIT IN AND FOR SARASOTA COUNTY, FLORIDA

**CASE NO.: 2026-CA-002805**  
**HB LAND HOLDINGS, LLC, a Florida Limited Liability Company,**  
Plaintiffs, v.  
**KATHERINE E. MCCLELLAN,**  
if living, and if dead, all unknown heirs, devisees, grantees, assignees, creditors, lienors, trustees, and all other parties claiming by, through, under, or against KATHERINE E. MCCLELLAN; and ALL UNKNOWN PERSONS OR UNKNOWN SPOUSES CLAIMING BY, THROUGH, UNDER, OR AGAINST ANY KNOWN OR UNKNOWN PERSON WHO IS NOT KNOWN TO BE DEAD OR ALIVE; and ALL PERSONS OR PARTIES HAVING OR CLAIMING TO HAVE ANY RIGHT, TITLE, OR INTEREST IN AND TO THE EASEMENTS RESERVED IN THE PLAT OF MCCLELLAN PARK, as recorded in Plat Book 2, Pages 10 and 11, of the Public Records of Manatee County, Florida, and Plat Book A, Pages 20 and 21, of the Public Records of Sarasota County, Florida.  
Defendants.

TO: KATHERINE E. MCCLELLAN, whose last known address at the time of her death in 1934 was: Sixth, Sarasota FL (information provided by sister, deceased); and all parties claiming by, through, under, and against the herein named individual defendant(s) who are not known to be dead or alive, whether said unknown parties may claim an interest as spouses, heirs, devisees, grantees, or other claimants; and ALL OTHERS WHOM IT MAY CONCERN:

YOU ARE HEREBY NOTIFIED that Plaintiff, HB Land Holdings, LLC, A Florida Limited Liability Company, has filed an action against you in the Circuit Court for Sarasota County to Quiet the Title related to certain real property located and situated in Sarasota County, Florida, located at 2315 McClellan Parkway, Sarasota FL 34239, and described as follows:

Lot 10, less the South 15 feet

thereof, all of Lots 1 and Lot 11, Block F, McCLELLAN PARK, according to the plat thereof, as recorded in Plat Book 2, Pages 10 and 11, Public Records of Manatee County, Florida, and Plat Book A, Pages 20 and 21, Public Records of Sarasota County, Florida.  
The Sarasota County Parcel Id. Number for the Property is 2038-07-0018.

The case is HB Land Holdings, LLC, a Florida Limited Liability Company v. Katherine E. McClellan et al., Case No. 2026 CA002805 NC, filed with the 12th Judicial Circuit Court of Sarasota County, Florida. You are required to serve a copy of your written defenses, if any, to the Hunter G. Norton, Esquire, of Shumaker, Loop & Kendrick, LLP, P.O. Box 49948, Sarasota, Florida 34230, the Plaintiff's attorney, on or before thirty (30) days after the date of first publication of this Notice of Action in the Business Observer which will run for a period of 4 weeks (once a week for 4 consecutive weeks), and file the original with the clerk of this court either before service on the Plaintiff's attorney or immediately thereafter; otherwise a default will be entered against you for the relief demanded in the Complaint or Petition.

If you are a person with a disability who needs any accommodation in order to participate in this proceeding, you are entitled, at no cost to you, to the provision of certain assistance. Please contact the Sarasota County Jury Office, P.O. Box 3079, Sarasota, Florida 34230-3079, (941)861-7400, at least seven (7) days before your scheduled court appearance, or immediately upon receiving this notification if the time before the scheduled appearance is less than seven (7) days; if you are hearing or voice impaired, call 711.

Dated: May 28, 2026  
KAREN E RUSHING, CLERK  
Clerk of the Court, Sarasota County  
(SEAL) By: Glen Kopinsky  
As Deputy Clerk  
Hunter G. Norton, Esquire,  
Shumaker, Loop & Kendrick, LLP,  
P.O. Box 49948,  
Sarasota, Florida 34230,  
#39684178v1  
June 5, 12, 19, 26, 2026 26-01226S

## SECOND INSERTION

**NOTICE OF SALE**  
IN THE CIRCUIT COURT OF THE TWELFTH JUDICIAL CIRCUIT IN AND FOR SARASOTA COUNTY, FLORIDA  
CIVIL DIVISION  
**Case #: 2020 CA 000023 NC**  
DIVISION: C

**Wells Fargo Bank, N.A. as Trustee for WaMu Mortgage Pass-Through Certificates Series 2006-PR1 Trust Plaintiff, -vs.- GARY R. DUVAL; CHERYL L. DUVAL; UNKNOWN PARTIES IN POSSESSION #1 whose name is fictitious to account for parties in possession**  
Defendant(s).

NOTICE IS HEREBY GIVEN pursuant to order rescheduling foreclosure sale or Final Judgment, entered in Civil Case No. 2020 CA 000023 NC of the Circuit Court of the 12th Judicial Circuit in and for Sarasota County, Florida, wherein Wells Fargo Bank, N.A. as Trustee for WaMu Mortgage Pass-Through Certificates Series 2006-PR1 Trust, Plaintiff and Gary R. Duvall a/k/a Gary Duvall are defendant(s), I, Clerk of Court, Karen E. Rushing, will sell to the highest and best bidder for cash VIA THE INTERNET AT WWW.SARASOTA.REALFORECLOSE.COM, AT 9:00 A.M. on July 9, 2026, the following described property as set forth in said Final Judgment, to-wit:

THE SOUTHEASTERLY 31.34 FEET OF LOT 1187 AND THE NORTHWESTERLY 44.52 FEET OF LOT 1186, OF VEN-

ICE GARDENS UNIT NO. 17, ACCORDING TO THE PLAT THEREOF AS RECORDED IN PLAT BOOK 16, PAGES 10 AND 10-A, OF THE PUBLIC RECORDS OF SARASOTA COUNTY, FLORIDA.

ANY PERSON CLAIMING AN INTEREST IN THE SURPLUS FROM THE SALE, IF ANY, OTHER THAN THE PROPERTY OWNER AS OF THE DATE OF THE LIS PENDENS MUST FILE A CLAIM NO LATER THAN THE DATE THAT THE CLERK REPORTS THE FUNDS AS UNCLAIMED.

If you are a person with a disability who needs any accommodation in order to participate in this proceeding, you are entitled, at no cost to you, to the provision of certain assistance. Please contact the Sarasota County Jury Office, P.O. Box 3079, Sarasota, Florida 34230-3079, (941)861-7400, at least seven (7) days before your scheduled court appearance, or immediately upon receiving this notification if the time before the scheduled appearance is less than seven (7) days; if you are hearing or voice impaired, call 711.

Submitted By: ATTORNEY FOR PLAINTIFF:  
LOGS LEGAL GROUP LLP  
750 Park of Commerce Blvd., Suite 130  
Boca Raton, Florida 33487  
(561) 998-6700  
(561) 998-6707  
20-324418 FCO1 SPS  
June 19, 26, 2026 26-01410S

## SECOND INSERTION

**NOTICE OF FORECLOSURE SALE**  
IN THE CIRCUIT COURT FOR THE TWELFTH JUDICIAL CIRCUIT IN AND FOR SARASOTA COUNTY, FLORIDA  
CIRCUIT CIVIL DIVISION  
**CASE NO.: 2025 CA 003825 NC**  
**NEWREZ LLC D/B/A SHELLPOINT MORTGAGE SERVICING**

**Plaintiff(s), vs. BRANDON D. WRIGHT AKA BRANDON WRIGHT; UNITED STATES OF AMERICA; TAYLOR P. GIBSON; THE UNKNOWN SPOUSE OF BRANDON D. WRIGHT AKA BRANDON WRIGHT; THE UNKNOWN SPOUSE OF TAYLOR P. GIBSON; THE UNKNOWN TENANT IN POSSESSION, Defendant(s).**

NOTICE IS HEREBY GIVEN THAT, pursuant to Plaintiff's Final Judgment of Foreclosure entered on April 16, 2026 in the above-captioned action, the Clerk of Court, Karen E. Rushing, will sell to the highest and best bidder for cash at www.sarasota.realforeclose.com in accordance with Chapter 45, Florida Statutes on the 15th day of July, 2026 at 09:00 AM on the following described property as set forth in said Final Judgment of Foreclosure or order, to wit:

LOT 1431, LAKE SARASOTA, UNIT NO. 16, ACCORDING TO THE PLAT THEREOF AS RECORDED IN PLAT BOOK 9, PAGE 22, OF THE PUBLIC RECORDS OF SARASOTA COUNTY, FLORIDA.

## SECOND INSERTION

**AMENDED NOTICE OF FORECLOSURE SALE**  
IN THE CIRCUIT COURT OF THE TWELFTH JUDICIAL CIRCUIT IN AND FOR SARASOTA COUNTY, FLORIDA  
GENERAL JURISDICTION DIVISION  
**CASE NO. 2024 CA 000241 NC**  
**U.S. BANK NATIONAL ASSOCIATION, AS TRUSTEE FOR GREENPOINT MORTGAGE FUNDING TRUST MORTGAGE PASS-THROUGH CERTIFICATES, SERIES 2007-AR2,**  
Plaintiff, vs.

**ANGELIKA U. CALLEN; MORTGAGE ELECTRONIC REGISTRATION SYSTEMS, INC., AS NOMINEE FOR RBS CITIZENS, N.A.; JACARANDA WEST HOMEOWNERS' ASSOCIATION #1, INC,**  
Defendant(s).

NOTICE IS HEREBY GIVEN pursuant to a Final Judgment of Foreclosure dated July 31, 2025, and entered in 2024 CA 000241 NC of the Circuit Court of the TWELFTH Judicial Circuit in and for Sarasota County, Florida, wherein U.S. BANK NATIONAL ASSOCIATION, AS TRUSTEE FOR GREENPOINT MORTGAGE FUNDING TRUST MORTGAGE PASS-THROUGH CERTIFICATES, SERIES 2007-AR2 is the Plaintiff and ANGELIKA U. CALLEN; MORTGAGE ELECTRONIC REGISTRATION SYSTEMS, INC., AS NOMINEE FOR RBS CITIZENS, N.A.; JACARANDA WEST HOMEOWNERS' ASSOCIATION #1, INC. are the Defendant(s). Karen E. Rushing as the Clerk of the Circuit Court will sell to the highest and best bidder for cash at www.sarasota.realforeclose.com, at 09:00 AM, on July 07, 2026, the following

Property address: 3968 Eton Place, Sarasota, FL 34241

Any person claiming an interest in the surplus from the sale, if any, other than the property owner as of the date of the lis pendens, must file a claim before the clerk reports the surplus as unclaimed.

Pursuant to the Fla. R. Jud. Admin. 2.516, the above signed counsel for Plaintiff designates attorney @ padgettlawgroup.com as its primary e-mail address for service, in the above styled matter, of all pleadings and documents required to be served on the parties.

If you are a person with a disability who needs any accommodation in order to participate in this proceeding, you are entitled, at no cost to you, to the provision of certain assistance. Please contact the Sarasota County Jury Office, P.O. Box 3079, Sarasota, Florida 34230-3079, (941)861-7400, at least seven (7) days before your scheduled court appearance, or immediately upon receiving this notification if the time before the scheduled appearance is less than seven (7) days; if you are hearing or voice impaired, call 711.

Respectfully submitted,  
PADGETT LAW GROUP  
STEVEN G. HURLEY, ESQ.  
Florida Bar # 99802  
6267 Old Water Oak Road, Suite 203  
Tallahassee, FL 32312  
(850) 422-2520 (telephone)  
(850) 422-2567 (facsimile)  
attorney@padgettlawgroup.com  
Attorney for Plaintiff  
TDP File No. 25-005673-1  
June 19, 26, 2026 26-01403S

## SECOND INSERTION

described property as set forth in said Final Judgment, to wit:

LOT 33145, UNIT 33, VENICE GARDENS, AS PER PLAT THEREOF RECORDED IN PLAT BOOK 22, PAGE 36, PUBLIC RECORDS OF SARASOTA COUNTY, FLORIDA.  
1608 BOB O LINK DR, VENICE, FL 34293

Any person claiming an interest in the surplus from the sale, if any, other than the property owner as of the date of the lis pendens must file a claim in accordance with Florida Statutes, Section 45.031.

If you are a person with a disability who needs any accommodation in order to participate in this proceeding, you are entitled, at no cost to you, to the provision of certain assistance. Please contact the Sarasota County Jury Office, P.O. Box 3079, Sarasota, Florida 34230-3079, (941)861-7400, at least seven (7) days before your scheduled court appearance, or immediately upon receiving this notification if the time before the scheduled appearance is less than seven (7) days; if you are hearing or voice impaired, call 711.

Dated this 16 day of June, 2026.  
ROBERTSON, ANSCHUTZ, SCHNEID, CRANE & PARTNERS, PLLC  
Attorney for Plaintiff  
6409 Congress Ave., Suite 100  
Boca Raton, FL 33487  
Telephone: 561-241-6901  
Facsimile: 561-997-6909  
Service Email: flmail@raslg.com  
By: /S/ Danielle Salem  
Danielle Salem, Esquire  
Florida Bar No. 0058248  
Communication Email:  
dsalem@raslg.com  
23-139731 - CyO  
June 19, 26, 2026 26-01411S

## SECOND INSERTION

**NOTICE TO CREDITORS**  
IN THE CIRCUIT COURT FOR SARASOTA COUNTY, FLORIDA  
PROBATE DIVISION  
**File No. 2026CP002840NC**  
Division Probate  
IN RE: ESTATE OF  
**JAY A. KLEIN**  
Deceased.

The administration of the estate of JAY A. KLEIN, deceased, whose date of death was March 7, 2026, is pending in the Circuit Court for Sarasota County, Florida, Probate Division, the address of which is Attn: Probate, 2000 Main Street, Sarasota, FL 34237. The names and addresses of the personal representative and the personal representative's attorney are set forth below.

All creditors of the decedent and other persons having claims or demands against decedent's estate on whom a copy of this notice is required to be served must file their claims with this court ON OR BEFORE THE LATER OF 3 MONTHS AFTER THE TIME OF THE FIRST PUBLICATION OF THIS NOTICE OR 30 DAYS AFTER THE DATE OF SERVICE OF A COPY OF THIS NOTICE ON THEM.

All other creditors of the decedent and other persons having claims or de-

mands against decedent's estate must file their claims with this court WITHIN 3 MONTHS AFTER THE DATE OF THE FIRST PUBLICATION OF THIS NOTICE.

ALL CLAIMS NOT FILED WITHIN THE TIME PERIODS SET FORTH IN FLORIDA STATUTES SECTION 733.702 WILL BE FOREVER BARRED.

NOTWITHSTANDING THE TIME PERIODS SET FORTH ABOVE, ANY CLAIM FILED TWO (2) YEARS OR MORE AFTER THE DECEDENT'S DATE OF DEATH IS BARRED.

The date of first publication of this notice is June 19, 2026.

**Personal Representative:**  
**KATHLEEN M. KLEIN**  
5633 Semolino Street  
Nokomis, FL 34275  
Attorney for Personal Representative:  
Dana Laganela Gerling, Esq.  
Florida Bar No. 0503991  
Affordable Attorney  
Gerling Law Group Chartered  
6148 State Road 70 East,  
Bradenton, FL 34203  
Telephone: (941) 756-6600  
Email:  
dlaganela@gerlinglawgroup.com  
June 19, 26, 2026 26-01420S

## SECOND INSERTION

**NOTICE TO CREDITORS**  
IN THE CIRCUIT COURT FOR SARASOTA COUNTY, FLORIDA  
PROBATE DIVISION  
**File No. 2026 CP 003008 NC**  
Division PROBATE  
IN RE: ESTATE OF  
**DONALD RAY OSWALT, Deceased.**

The administration of the estate of DONALD RAY OSWALT, deceased, whose date of death was May 1, 2026, is pending in the Circuit Court for Sarasota County, Florida, Probate Division, the address of which is PO Box 3079, Sarasota, FL 34230. The names and addresses of the personal representative and the personal representative's attorney are set forth below.

All creditors of the decedent and other persons having claims or demands against decedent's estate, on whom a copy of this notice is required to be served, must file their claims with this court ON OR BEFORE THE LATER OF 3 MONTHS AFTER THE TIME OF THE FIRST PUBLICATION OF THIS NOTICE OR 30 DAYS AFTER THE DATE OF SERVICE OF A COPY OF THIS NOTICE ON THEM.

All other creditors of the decedent and other persons having claims or de-

mands against decedent's estate must file their claims with this court WITHIN 3 MONTHS AFTER THE DATE OF THE FIRST PUBLICATION OF THIS NOTICE.

ALL CLAIMS NOT FILED WITHIN THE TIME PERIODS SET FORTH IN FLORIDA STATUTES SECTION 733.702 WILL BE FOREVER BARRED.

NOTWITHSTANDING THE TIME PERIOD SET FORTH ABOVE, ANY CLAIM FILED TWO (2) YEARS OR MORE AFTER THE DECEDENT'S DATE OF DEATH IS BARRED.

The date of first publication of this notice is: June 19, 2026.

**DALE EUGENE OSWALT**  
**Personal Representative**  
4249 Prairie View Dr. N  
Sarasota, FL 34232  
MARY LYNN DESJARLAIS  
Attorney for Personal Representative  
Florida Bar No. 0347469  
Desjarlais Law & Title  
2750 Stickney Point Rd #201  
Sarasota, FL 34231  
Telephone: 941-923-3388  
Email:  
mldesjarlais@attorneydesjarlais.com  
June 19, 26, 2026 26-01417S

## SECOND INSERTION

**NOTICE OF FORECLOSURE SALE**  
IN THE CIRCUIT COURT OF THE TWELFTH JUDICIAL CIRCUIT OF FLORIDA IN AND FOR SARASOTA COUNTY  
GENERAL JURISDICTION DIVISION  
**CASE NO. 2023 CA 003670 NC**  
**LIBERTY SAVINGS BANK, FSB,**  
Plaintiff, vs.  
**KATIMA A HALLOY, et al.,**  
Defendant.

NOTICE IS HEREBY GIVEN pursuant to a Summary Final Judgment of Foreclosure entered March 20, 2024 in Civil Case No. 2023 CA 003670 NC of the Circuit Court of the TWELFTH JUDICIAL CIRCUIT in and for Sarasota County, Sarasota, Florida, wherein LIBERTY SAVINGS BANK, FSB is Plaintiff and KATIMA A HALLOY, et al., are Defendants, the Clerk of Court, KAREN E. RUSHING, will sell to the highest and best bidder for cash electronically at www.sarasota.realforeclose.com in accordance with Chapter 45, Florida Statutes on the 16th day of July, 2026 at 9:00 AM on the following described property as set forth in said Summary Final Judgment, to-wit:

A PORTION OF LOT 44, MYAKKA VALLEY RANCHES, UNIT NO 2, AS PER PLAT THEREOF RECORDED IN PLAT BOOK 20, PAGES 4 AND 4A, PUBLIC RECORDS OF SARASOTA COUNTY, FLORIDA, DESCRIBED AS FOLLOWS:  
COMMENCE AT THE NW CORNER OF SECTION 17, TWP 37 SOUTH, RANGE 20 EAST, SARASOTA COUNTY, FLORIDA, AS SHOWN ON SAID PLAT OF MYAKKA VALLEY RANCHES, UNIT NO 2, FOR A P.O.B.; THENCE N 83 DEGREES 11 MINUTES 11 SECONDS E ALONG THE NORTHERLY LINE OF SAID LOT 44, A DISTANCE OF 445.81 FT TO THE NORTHEASTERLY CORNER THEREOF, BEING A POINT ON THE CENTER LINE OF A 100 FT PRIVATE ROADWAY EASEMENT (VANDERPIPE ROAD);

THENCE SOUTHEASTERLY ALONG SAID CENTERLINE, AND NORTHEASTERLY LINE OF LOT 44, AND ALONG THE ARC OF A CURVE, CONCAVE TO THE NORTHEAST, HAVING A RADIUS OF 358.10 FT THROUGH A CENTRAL ANGLE OF 45 DEGREES 18 MINUTES AND 08 SECONDS, A DISTANCE OF 283.14 FT; THENCE S 37 DEGREES 53 MINUTES AND 03 SECONDS W, 50 FT TO A POINT ON THE SOUTHWESTERLY R/W LINE OF SAID 100 FT PRIVATE ROAD EASEMENT; THENCE SOUTH 51 DEGREES 42 MINUTES 08 SECONDS W 218.57 FT TO A CONCRETE MONUMENT; THENCE S 37 DEGREES 33 MINUTES 39 SECONDS W, 629.17 FT TO A CONCRETE MONUMENT ON THE WEST LINE OF SAID LOT 44, SAID POINT LYING N 00 DEGREES 29 MINUTES 46 SECONDS E OF, AND 182.0 FT FROM THE S.W. CORNER OF SAID LOT 44; THENCE N 00 DEGREES 29 MINUTES 46 SECONDS E, ALONG SAID WEST LINE OF LOT 44, 860.96 FEET TO THE POINT OF BEGINNING.

Any person claiming an interest in the surplus from the sale, if any, other than the property owner as of the date of the lis pendens, must file a claim before the clerk reports the surplus as unclaimed.  
If you are a person with a disability who needs any accommodation in order to participate in this proceeding, you are entitled, at no cost to you, to the provision of certain assistance. Please contact the Sarasota County Jury Office, P.O. Box 3079, Sarasota, Florida 34230-3079, (941)861-7400, at least seven (7) days before your scheduled court appearance, or immediately upon receiving this notification if the time before the scheduled appearance is less than seven (7) days; if you are hearing or voice impaired, call 711.  
By: /s/ Robyn Katz  
Robyn Katz, Esq.  
McCalla Kaymer Leibert Pierce, LLP  
Attorney for Plaintiff  
225 East Robinson Street, Suite 155  
Orlando, FL 32801  
Phone: (407) 674-1850  
Fax: (321) 248-0420  
Email: MRSservice@mccalla.com  
Fla. Bar No.: 146803  
23-07801FL  
June 19, 26, 2026 26-01419S

--- ESTATE / PUBLIC SALES ---

SECOND INSERTION

NOTICE OF PUBLIC SALE

Extra Space Storage will hold a public auction to sell personal property described below belonging to those individuals listed below at the location indicated:  
4173 Clark Rd. Sarasota, FL 34233  
07/09/2026 at 10:00 AM  
Shaune Johnson  
Furniture, tools, clothes  
The auction will be listed and advertised on www.storage-treasures.com. Purchases must be made with cash only and paid at the above referenced facility in order to complete the transaction. Extra Space Storage may refuse any bid and may rescind any purchase up until the winning bidder takes possession of the personal property.  
June 19, 26, 2026 26-01371S

SECOND INSERTION

NOTICE TO CREDITORS  
IN THE CIRCUIT COURT FOR  
SARASOTA COUNTY, FLORIDA  
PROBATE DIVISION  
File No. 2026-CP-002087NC  
Division Probate  
IN RE: ESTATE OF  
SONIA P. FUENTES, a/k/a  
SONIA PRESSMAN FUENTES,  
Deceased.

The administration of the estate of Sonia P. Fuentes, deceased, whose date of death was December 20, 2025, is pending in the Circuit Court for Sarasota County, Florida, Probate Division, the address of which is 2000 Main Street, Sarasota, FL 34236. The names and addresses of the personal representative and the personal representative's attorney are set forth below.

All creditors of the decedent and other persons having claims or demands against decedent's estate on whom a copy of this notice is required to be served must file their claims with this court ON OR BEFORE THE LATER OF 3 MONTHS AFTER THE TIME OF THE FIRST PUBLICATION OF THIS NOTICE OR 30 DAYS AFTER THE DATE OF SERVICE OF A COPY OF THIS NOTICE ON THEM.

All other creditors of the decedent and other persons having claims or demands against decedent's estate must file their claims with this court WITHIN 3 MONTHS AFTER THE DATE OF THE FIRST PUBLICATION OF THIS NOTICE.

The personal representative has no duty to discover whether any property

held at the time of the decedent's death by the decedent or the decedent's surviving spouse is property to which the Florida Uniform Disposition of Community Property Rights at Death Act as described in ss. 732.216-732.228, Florida Statutes, applies, or may apply, unless a written demand is made by a creditor as specified under s. 732.2211, Florida Statutes. The written demand must be filed with the clerk.

ALL CLAIMS NOT FILED WITHIN THE TIME PERIODS SET FORTH IN FLORIDA STATUTES SECTION 733.702 WILL BE FOREVER BARRED.

NOTWITHSTANDING THE TIME PERIODS SET FORTH ABOVE, ANY CLAIM FILED TWO (2) YEARS OR MORE AFTER THE DECEDENT'S DATE OF DEATH IS BARRED.

The date of first publication of this notice is June 19, 2026.

Personal Representative:

Nancy Gold

4876 Peregrine Point Circle N.  
Sarasota, Florida 34231

Attorney for Personal Representative:

David M. Silberstein

Florida Bar Number: 0436879

BCS - Wills, Trusts and

Estates Attorney

BCS - Tax Law

SILBERSTEIN LAW FIRM, PLLC

1515 Ringling Blvd. #860

Sarasota, FL 34236

Telephone: (941) 953-4400

Fax: (941) 953-4450

E-Mail: david@silbersteinlawfirm.com

June 19, 26, 2026 26-01406S

SECOND INSERTION

NOTICE TO CREDITORS  
IN THE CIRCUIT COURT OF THE  
TWELFTH JUDICIAL CIRCUIT IN  
AND FOR SARASOTA COUNTY,  
FLORIDA  
File No. 2026-CP-001766NC  
Division PROBATE  
IN RE: ESTATE OF  
FINIS E. WILLIAMS, JR.  
Deceased.

The administration of the estate of Finis E. Williams, Jr., deceased, whose date of death was January 12, 2026, is pending in the Circuit Court for Sarasota County, Florida, Probate Division, the address of which is 2000 Main Street, Sarasota, FL 34237. The names and addresses of the personal representative and the personal representative's attorney are set forth below.

All creditors of the decedent and other persons having claims or demands against decedent's estate on whom a copy of this notice is required to be served must file their claims with this court ON OR BEFORE THE LATER OF 3 MONTHS AFTER THE TIME OF THE FIRST PUBLICATION OF THIS NOTICE OR 30 DAYS AFTER THE DATE OF SERVICE OF A COPY OF THIS NOTICE ON THEM.

All other creditors of the decedent and other persons having claims or demands against decedent's estate must file their claims with this court WITHIN 3 MONTHS AFTER THE DATE OF THE FIRST PUBLICATION OF THIS NOTICE.

The personal representative has no

duty to discover whether any property held at the time of the decedent's death by the decedent or the decedent's surviving spouse is property to which the Florida Uniform Disposition of Community Property Rights at Death Act as described in ss. 732.216-732.228, applies, or may apply, unless a written demand is made by a creditor as specified under s. 732.2211, Florida Statutes. The written demand must be filed with the clerk.

ALL CLAIMS NOT FILED WITHIN THE TIME PERIODS SET FORTH IN FLORIDA STATUTES SECTION 733.702 WILL BE FOREVER BARRED.

NOTWITHSTANDING THE TIME PERIODS SET FORTH ABOVE, ANY CLAIM FILED TWO (2) YEARS OR MORE AFTER THE DECEDENT'S DATE OF DEATH IS BARRED.

The date of first publication of this notice is June 19, 2026.

Finis E. Williams, III,  
Personal Representative

15 Ridge Road

Concord, NH 03301

Charles M. Kelly, Jr., Esq.

Attorney for

Personal Representative

Florida Bar No. 364495

2390 Tamiami Trail North, Suite 204

Naples, FL 34103

239-261-3453

Email Addresses:

ckelly@flintrust.com

groupservice@flintrust.com

June 19, 26, 2026 26-01373S

SECOND INSERTION

NOTICE TO CREDITORS  
IN THE CIRCUIT COURT FOR  
SARASOTA COUNTY,  
FLORIDA  
PROBATE DIVISION  
File No. 2026 CP 2444 NC  
Division PROBATE  
IN RE: ESTATE OF  
PHYLLIS ANN KESTERSON  
Deceased.

The administration of the estate of Phyllis Ann Kesterson, deceased, whose date of death was February 24, 2026, is pending in the Circuit Court for SARASOTA County, Florida, Probate Division, the address of which is PO Box 3079, Sarasota, Florida 34230. The names and addresses of the personal representative and the personal representative's attorney are set forth below.

All creditors of the decedent and other persons having claims or demands against decedent's estate on whom a copy of this notice is required to be served must file their claims with this court ON OR BEFORE THE LATER OF 3 MONTHS AFTER THE TIME OF THE FIRST PUBLICATION OF THIS NOTICE OR 30 DAYS AFTER THE DATE OF SERVICE OF A COPY OF THIS NOTICE ON THEM.

All other creditors of the decedent and other persons having claims or demands against decedent's estate must file their claims with this court WITHIN 3 MONTHS AFTER THE DATE OF THE FIRST PUBLICATION OF THIS NOTICE.

The personal representative has no

held at the time of the decedent's death by the decedent or the decedent's surviving spouse is property to which the Florida Uniform Disposition of Community Property Rights at Death Act as described in ss. 732.216-732.228, Florida Statutes, applies, or may apply, unless a written demand is made by a creditor as specified under s. 732.2211, Florida Statutes. The written demand must be filed with the clerk.

ALL CLAIMS NOT FILED WITHIN THE TIME PERIODS SET FORTH IN FLORIDA STATUTES SECTION 733.702 WILL BE FOREVER BARRED.

NOTWITHSTANDING THE TIME PERIODS SET FORTH ABOVE, ANY CLAIM FILED TWO (2) YEARS OR MORE AFTER THE DECEDENT'S DATE OF DEATH IS BARRED.

The date of first publication of this notice is June 19, 2026.

Personal Representative:

Tammy Underwood

12463 Steen Terrace

Port Charlotte, Florida 33981

Attorney for Personal Representative:

T. Thomas Shirley

Attorney

Florida Bar Number: 154581

Dunkin & Shirley, P.A.

170 West Dearborn Street

Englewood, Florida 34223

Telephone: (941) 474-7753

Fax: (941) 475-1954

E-Mail: tom@dunkinshirley.com

Secondary E-Mail:

a4@dunkinshirley.com

June 19, 26, 2026 26-01384S

SECOND INSERTION

NOTICE OF PUBLIC SALE

Extra Space Storage will hold a public auction to sell personal property described below belonging to those individuals listed below at the location indicated:  
5700 Anise Drive, Sarasota FL 34238 on 07/09/2026 at 10:00AM  
Daniel Harper  
Household items  
The auction will be listed and advertised on www.storage-treasures.com. Purchases must be made with cash only and paid at the above referenced facility in order to complete the transaction. Extra Space Storage may refuse any bid and may rescind any purchase up until the winning bidder takes possession of the personal property.  
June 19, 26, 2026 26-01370S

SECOND INSERTION

NOTICE TO CREDITORS  
(Summary Administration)  
IN THE CIRCUIT COURT FOR  
SARASOTA COUNTY,  
FLORIDA  
PROBATE DIVISION  
File No. 2026 CP 3292 NC  
Division Probate  
IN RE: ESTATE OF  
JOHN F. PHILLIPS  
Deceased.

TO ALL PERSONS HAVING CLAIMS OR DEMANDS AGAINST THE ABOVE ESTATE:

You are hereby notified that an Order of Summary Administration has been entered in the estate of John F. Phillips, deceased, File Number 2026 CP 3295 NC, by the Circuit Court for Sarasota County, Florida, Probate Division, the address of which is 2002 Ringling Blvd., Sarasota, FL 34237; that the decedent's date of death was May 7, 2026; that the total value of the estate is \$12,136.00 and that the names and addresses of those to whom it has been assigned by such order are:

Name Address

Ashley Lauren Moore 9868 Minister

Lane Frisco, TX 75035

ALL INTERESTED PERSONS ARE

NOTIFIED THAT:

All creditors of the estate of the decedent and persons having claims or demands against the estate of the decedent other than those for whom provision for full payment was made in the Order of Summary Administration must file their claims with this court WITHIN THE TIME PERIODS SET

FORTH IN FLORIDA STATUTES SECTION 733.702. ALL CLAIMS AND DEMANDS NOT SO FILED WILL BE FOREVER BARRED. NOTWITHSTANDING ANY OTHER APPLICABLE TIME PERIOD, ANY CLAIM FILED TWO (2) YEARS OR MORE AFTER THE DECEDENT'S DATE OF DEATH IS BARRED.

The personal representative has no duty to discover whether any property held at the time of the decedent's death by the decedent or the decedent's surviving spouse is property to which the Florida Uniform Disposition of Community Property Rights at Death Act as described in sections 732.216-732.288 Florida Statutes, applies, or may apply, unless a written demand is made by a creditor as specified under section 732.2211, Florida Statutes. The written demand must be filed with the clerk.

The date of first publication of this Notice is June 19, 2026.

Person Giving Notice:

Ashley Lauren Moore

9868 Minister Lane

Frisco, Texas 75035

Attorney for Person Giving Notice

Christopher D. Smith, Esq.

Attorney for Petitioner

Florida Bar Number: 0605433

1561 Lakefront Dr Unit 204

SARASOTA, FL 34240

Telephone: (941) 202-2222

Fax: (941) 907-3040

E-Mail: smith@chrissmith.com

Secondary E-Mail:

paralegals@chrissmith.com

June 19, 26, 2026 26-01386S

SECOND INSERTION

NOTICE TO CREDITORS  
IN THE CIRCUIT COURT FOR  
SARASOTA COUNTY,  
FLORIDA  
PROBATE DIVISION  
File No. 2026 CP 2692 NC  
Division Probate  
IN RE: ESTATE OF  
FRANCIS L. FINN III  
Deceased.

The administration of the estate of Francis L. Finn III, deceased, whose date of death was November 7, 2025, is pending in the Circuit Court for Sarasota County, Florida, Probate Division, the address of which is PO Box 3079, Sarasota, Florida 34230. The names and addresses of the personal representative and the personal representative's attorney are set forth below.

All creditors of the decedent and other persons having claims or demands against decedent's estate on whom a copy of this notice is required to be served must file their claims with this court ON OR BEFORE THE LATER OF 3 MONTHS AFTER THE TIME OF THE FIRST PUBLICATION OF THIS NOTICE OR 30 DAYS AFTER THE DATE OF SERVICE OF A COPY OF THIS NOTICE ON THEM.

All other creditors of the decedent and other persons having claims or demands against decedent's estate must file their claims with this court WITHIN 3 MONTHS AFTER THE DATE OF THE FIRST PUBLICATION OF THIS NOTICE.

The personal representative has no

duty to discover whether any property held at the time of the decedent's death by the decedent or the decedent's surviving spouse is property to which the Florida Uniform Disposition of Community Property Rights at Death Act as described in ss. 732.216-732.228, Florida Statutes, applies, or may apply, unless a written demand is made by a creditor as specified under s. 732.2211, Florida Statutes. The written demand must be filed with the clerk.

ALL CLAIMS NOT FILED WITHIN THE TIME PERIODS SET FORTH IN FLORIDA STATUTES SECTION 733.702 WILL BE FOREVER BARRED.

NOTWITHSTANDING THE TIME PERIODS SET FORTH ABOVE, ANY CLAIM FILED TWO (2) YEARS OR MORE AFTER THE DECEDENT'S DATE OF DEATH IS BARRED.

The date of first publication of this notice is June 19, 2026.

Personal Representative:

Francis L. Finn IV

3389 Rain Lily Lane

Englewood, Florida 34224

Attorney for Personal Representative:

T. Thomas Shirley

Attorney

Florida Bar Number: 154581

Dunkin & Shirley, P.A.

170 West Dearborn Street

Englewood, Florida 34223

Telephone: (941) 474-7753

Fax: (941) 475-1954

E-Mail: tom@dunkinshirley.com

June 19, 26, 2026 26-01385S

SECOND INSERTION

NOTICE TO CREDITORS  
IN THE CIRCUIT COURT OF THE  
TWELFTH JUDICIAL CIRCUIT  
IN AND FOR SARASOTA COUNTY,  
FLORIDA PROBATE DIVISION  
File No. 2026-CP-2688 NC  
IN RE: ESTATE OF:  
MARY ANN COLTER,  
Deceased.

The administration of the estate of MARY ANN COLTER, deceased, whose date of death was March 30, 2026; is pending in the Circuit Court for Sarasota County, Florida, Probate Division, the address of which is Post Office Box 3079, Sarasota, FL 34230. The names and addresses of the personal representative and the personal representative's attorney are set forth below.

All creditors of the decedent and other persons having claims or demands against decedent's estate, on whom a copy of this notice is required to be served must file their claims with this court ON OR BEFORE THE LATER OF 3 MONTHS AFTER THE TIME OF THE FIRST PUBLICATION OF THIS NOTICE OR 30 DAYS AFTER THE DATE OF SERVICE OF A COPY OF THIS NOTICE ON THEM.

All other creditors of the decedent and other persons having claims or demands against decedent's estate must file their claims with this court WITHIN 3 MONTHS AFTER THE DATE OF THE FIRST PUBLICATION OF THIS NOTICE.

The personal representative has no duty to discover whether any property held at the time of the decedent's death

by the decedent or the decedent's surviving spouse is property to which the Florida Uniform Disposition of Community Property Rights at Death Act as described in sections 732.216-732.228, Florida Statutes, applies, or may apply, unless a written demand is made by the surviving spouse or a beneficiary as specified under section 732.2211, Florida Statutes. The written demand must be filed with the Court.

ALL CLAIMS NOT FILED WITHIN THE TIME PERIODS SET FORTH IN FLORIDA STATUTES SECTION 733.702 WILL BE FOREVER BARRED.

NOTWITHSTANDING THE TIME PERIOD SET FORTH ABOVE, ANY CLAIM FILED TWO (2) YEARS OR MORE AFTER THE DECEDENT'S DATE OF DEATH IS BARRED.

The date of first publication of this notice is: June 19, 2026.

EUGENE M. COLTER, JR.  
Personal Representative

10 Hanover Street

Apartment 3U

New York, NY 10005

DAVE M. EVANS, JR., Esquire

Attorney for Personal Representative

Florida Bar No. 1013511

LEE & EVANS, P.A.

2601 Cattleman Road, Suite 503

Sarasota, Florida 34232

Telephone: (941) 954-0067

Facsimile: (941) 365-1492

Email: devans@leeandevans.com

Secondary Email:

kristina@leeandevans.com

June 19, 26, 2026 26-01354S

SECOND INSERTION

NOTICE OF PUBLIC SALE

Extra Space Storage, on behalf of itself or its affiliates, Life Storage or Storage Express, will hold a public auction to sell personal property described below belonging to those individuals listed below at the location indicated:  
997 Center Rd. Venice, FL 34293  
07/09/26 - 10:00am  
Kaleb Monk Household Goods  
The auction will be listed and advertised on www.storage-treasures.com. Purchases must be made with cash only and paid at the above referenced facility in order to complete the transaction. Extra Space Storage may refuse any bid and may rescind any purchase up until the winning bidder takes possession of the personal property  
June 19, 26, 2026 26-01344S

SECOND INSERTION

NOTICE TO CREDITORS  
IN THE CIRCUIT COURT FOR  
SARASOTA COUNTY,  
FLORIDA PROBATE DIVISION  
File No. 2026 CP 002639 SC  
IN RE: ESTATE OF  
WILLIAM EWERS JONES,  
Deceased.

The administration of the estate of William Ewers Jones, deceased, whose date of death was 12/02/2025, is pending in the Circuit Court for Sarasota County, Florida, Probate Division, File No. 2026 CP 002639 SC, the address of which is 2000 Main Street, Sarasota, FL 34237. The names and addresses of the Personal Representative and the Personal Representative's attorney are set forth below.

The Personal Representative has no duty to discover whether any property held at the time of the Decedent's death by the Decedent or the Decedent's surviving spouse is property to which the Florida Uniform Disposition of Community Property Rights at Death Act as described in ss. 732.216-732.228, Florida Statutes, applies, or may apply, unless a written demand is made by a creditor as specified under s. 732.2211, Florida Statutes.

All creditors of the Decedent and other persons, having claims or demands against Decedent's estate, on whom a copy of this notice is required to be served, must file their claims with this court WITHIN THE LATER OF THREE (3) MONTHS AFTER THE TIME OF THE FIRST PUBLICATION

OF THIS NOTICE OR THIRTY (30) DAYS AFTER THE DATE OF SERVICE OF A COPY OF THIS NOTICE ON THEM.

All other creditors of the Decedent and other persons having claims or demands against Decedent's estate must file their claims with this court WITHIN THREE (3) MONTHS AFTER THE DATE OF THE FIRST PUBLICATION OF THIS NOTICE.

ALL CLAIMS NOT FILED WITHIN THE TIME PERIODS SET FORTH IN SECTION 733.702 OF THE FLORIDA PROBATE CODE WILL BE FOREVER BARRED.

NOTWITHSTANDING THE TIME PERIODS SET FORTH ABOVE, ANY CLAIM FILED TWO (2) YEARS OR MORE AFTER THE DECEDENT'S DATE OF DEATH IS BARRED.

THE DATE OF THE FIRST PUBLICATION OF THIS NOTICE IS June 19, 2026.

Personal Representative:

Kimberly A. Hill

103 Hackett Lane

Pass Christian, MS 39571

Attorney for Personal Representative

Kathlyn M. White (FBN: 13763)

Attorney for Personal Representative

DeMaria & White, PLLC

905 E. Hatton St., Ste. B

Pensacola, FL 32503

(850) 202-8535

kmwhite@statwideprobate.com

dmcln@statwideprobate.com</

## --- ACTIONS / SALES ---

## SECOND INSERTION

**NOTICE OF FORECLOSURE SALE IN THE CIRCUIT COURT OF THE TWELFTH JUDICIAL CIRCUIT OF FLORIDA IN AND FOR SARASOTA COUNTY**

GENERAL JURISDICTION DIVISION  
**CASE NO. 2025 CA 004192 NC**  
**FREEDOM MORTGAGE CORPORATION,**  
**Plaintiff, vs.**  
**JOSEPH PERRY A/K/A JOSEPH R PERRY, et al.,**  
**Defendant.**

NOTICE IS HEREBY GIVEN pursuant to a Summary Final Judgment of Foreclosure entered April 15, 2026 in Civil Case No. 2025 CA 004192 NC of the Circuit Court of the TWELFTH JUDICIAL CIRCUIT in and for Sarasota County, Florida, wherein FREEDOM MORTGAGE CORPORATION is Plaintiff and Joseph Perry a/k/a Joseph R Perry, et al., are Defendants, the Clerk of Court, KAREN E. RUSHING, will sell to the highest and best bidder for cash electronically at www.sarasota.realforeclose.com in accordance with Chapter 45, Florida Statutes on the 14th day of July, 2026 at 9:00 AM on the following described property as set forth in said Summary Final Judgment, to-wit:

Lot 15, Block 1861, 39TH ADDITION TO PORT CHARLOTTE

SUBDIVISION, according to the Plat thereof as recorded in Plat Book 16, Page 14, Public Records of Sarasota County, Florida

Any person claiming an interest in the surplus from the sale, if any, other than the property owner as of the date of the lis pendens, must file a claim before the clerk reports the surplus as unclaimed.

If you are a person with a disability who needs any accommodation in order to participate in this proceeding, you are entitled, at no cost to you, to the provision of certain assistance. Please contact the Sarasota County Jury Office, P.O. Box 3079, Sarasota, Florida 34230-3079, (941)861-7400, at least seven (7) days before your scheduled court appearance, or immediately upon receiving this notification if the time before the scheduled appearance is less than seven (7) days; if you are hearing or voice impaired, call 711.

By: /s/Robyn Katz  
 Robyn Katz, Esq.  
 McCalla Raymer Leibert Pierce, LLP  
 Attorney for Plaintiff  
 225 East Robinson Street, Suite 155  
 Orlando, FL 32801  
 Phone: (407) 674-1850  
 Fax: (321) 248-0420  
 Email: MRService@mccalla.com  
 Fla. Bar No.: 146803  
 24-10401FL  
 June 19, 26, 2026 26-01399S

## SECOND INSERTION

**NOTICE OF ACTION IN THE CIRCUIT COURT OF THE TWELFTH JUDICIAL CIRCUIT OF FLORIDA IN AND FOR SARASOTA COUNTY**

GENERAL JURISDICTION DIVISION  
**CASE NO. 2026 CA 000486 NC**  
**GUILD MORTGAGE COMPANY LLC,**  
**Plaintiff, vs.**  
**PAIGE RAMEY, et al.,**  
**Defendant.**

To: PAIGE RAMEY  
 2030 OMEGA CT, NORTH PORT, FL 34288

YOU ARE HEREBY NOTIFIED that an action to foreclose mortgage covering the following real and personal property described as follows, to-wit:

LOT 34, BLOCK 2583, FIFTY-FIRST ADDITION TO PORT CHARLOTTE SUBDIVISION, ACCORDING TO THE MAP OR PLAT THEREOF, AS RECORDED IN PLAT BOOK 21, PAGES 8 AND 8A THROUGH 8GG, INCLUSIVE, OF THE PUBLIC RECORDS OF SARASOTA COUNTY, FLORIDA.

has been filed against you and you are required to file a copy of your written defenses, if any, to it, on Jacqueline T.

Levine, Esq., McCalla Raymer Leibert Pierce, LLP, 225 East Robinson Street, Suite 155, Orlando, FL 32801 and file the original with the Clerk of the above-styled Court on or before July 20, 2026 or 30 days from the first publication, otherwise a Judgment may be entered against you for the relief demanded in the Complaint.

If you are a person with a disability who needs any accommodation in order to participate in this proceeding, you are entitled, at no cost to you, to the provision of certain assistance. Please contact the Sarasota County Jury Office, P.O. Box 3079, Sarasota, Florida 34230-3079, (941)861-7400, at least seven (7) days before your scheduled court appearance, or immediately upon receiving this notification if the time before the scheduled appearance is less than seven (7) days; if you are hearing or voice impaired, call 711.

WITNESS my hand and seal of said Court on the 12 day of June, 2026.

KAREN E. RUSHING  
 CLERK OF COURT  
 OF SARASOTA COUNTY  
 BY: G. Kopinsky  
 Deputy Clerk

25-15410FL  
 June 19, 26, 2026 26-01376S

## SECOND INSERTION

**NOTICE OF SALE IN THE CIRCUIT COURT OF THE TWELFTH JUDICIAL CIRCUIT IN AND FOR SARASOTA COUNTY, FLORIDA**

CIVIL DIVISION  
**Case #: 2025 CA 005184 NC**  
**DIVISION: G**

**PNC Bank, National Association Plaintiff, vs.-**  
**Nadezhda Sergiyenko; Unknown Spouse of Nadezhda Sergiyenko; Bella Villino III Condominium Association, Inc.; Unknown Parties in Possession #1, if living, and all Unknown Parties claiming by, through, under and against the above named Defendant(s); Unknown Parties in Possession #2, if living, and all Unknown Parties claiming by, through, under and against the above named Defendant(s)**

NOTICE IS HEREBY GIVEN pursuant to order rescheduling foreclosure sale or Final Judgment, entered in Civil Case No. 2025 CA 005184 NC of the Circuit Court of the 12th Judicial Circuit in and for Sarasota County, Florida, wherein PNC Bank, National Association, Plaintiff and Nadezhda Sergiyenko are defendant(s), I, Clerk of Court, Karen E. Rushing, will sell to the highest and best bidder for cash VIA THE INTERNET AT WWW.SARASOTA.REALFORECLOSE.COM, at 9:00 A.M. on July 14, 2026, the following described property as set forth in said Final Judgment, to-wit:

UNIT 1923, BUILDING B, BELLA VILLINO III, A CONDOMINIUM, ACCORDING TO THE DECLARATION OF CON-

DOMINIUM THEREOF, AS RECORDED IN OFFICIAL RECORDS INSTRUMENT NUMBER 2005140552, AS THEREAFTER AMENDED, AND AS PER PLAT THEREOF RECORDED IN CONDOMINIUM BOOK 38, PAGE 4, AS THEREAFTER AMENDED, OF THE PUBLIC RECORDS OF SARASOTA COUNTY, FLORIDA.

ANY PERSON CLAIMING AN INTEREST IN THE SURPLUS FROM THE SALE, IF ANY, OTHER THAN THE PROPERTY OWNER AS OF THE DATE OF THE LIS PENDENS MUST FILE A CLAIM NO LATER THAN THE DATE THAT THE CLERK REPORTS THE FUNDS AS UNCLAIMED.

If you are a person with a disability who needs any accommodation in order to participate in this proceeding, you are entitled, at no cost to you, to the provision of certain assistance. Please contact the Sarasota County Jury Office, P.O. Box 3079, Sarasota, Florida 34230-3079, (941)861-7400, at least seven (7) days before your scheduled court appearance, or immediately upon receiving this notification if the time before the scheduled appearance is less than seven (7) days; if you are hearing or voice impaired, call 711.

Submitted By: ATTORNEY FOR PLAINTIFF:  
 LOGS LEGAL GROUP LLP  
 750 Park of Commerce Blvd., Suite 130  
 Boca Raton, Florida 33487  
 (561) 998-6700  
 (561) 998-6707  
 25-334058 FC01 NCM  
 June 19, 26, 2026 26-01345S

## SECOND INSERTION

**NOTICE OF SALE PURSUANT TO CHAPTER 45**

IN THE CIRCUIT COURT OF THE 12TH JUDICIAL CIRCUIT, IN AND FOR SARASOTA COUNTY, FLORIDA

**CASE NO.: 2025-CA-001463**  
**U.S. BANK TRUST NATIONAL ASSOCIATION, AS TRUSTEE FOR LB-TREEHOUSE SERIES VI TRUST,**  
**Plaintiff, v.**  
**GARY ANDREW BARSHAW, et al,**  
**Defendant(s).**

NOTICE IS HEREBY GIVEN that pursuant to a Final Judgment in Foreclosure entered on April 15, 2026 and entered in Case No. 2025-CA-001463 in the Circuit Court of the 12th Judicial Circuit in and for Sarasota County, Florida, wherein GARY ANDREW BARSHAW, et al., are the Defendants. The Clerk of the Court, KAREN E. RUSHING, will sell to the highest bidder for cash at https://www.sarasota.realforeclose.com on October 15, 2026 at 9:00am, the following described real property as set forth in said Final Judgment, to wit:

THE WEST 149 FEET OF THE FOLLOWING DESCRIBED PROPERTY: BEGIN AT THE SW CORNER OF THE SW 1/4 OF THE SW 1/4 OF THE SE 1/4 OF SECTION 14, TOWNSHIP 36 SOUTH, RANGE 18 EAST; THENCE NORTHERLY ALONG THE 1/4 SECTION LINE 180 FEET FOR A POINT OF BEGINNING; THENCE CONTINUE NORTHERLY ON SAID LINE 86.4 FEET; THENCE E. AND PARALLEL TO THE SOUTH LINE OF SAID SW 1/4 OF THE SW 1/4 OF THE SE 1/4, 515.6 FEET; THENCE SOUTH AND PARALLEL TO THE EAST LINE OF SAID SOUTHWEST 1/4 OF THE SW 1/4 OF THE SE 1/4, 86.4 FEET; THENCE WEST 515.9 FEET TO THE POINT OF BEGINNING; LESS THE WEST 25 FEET FOR ROAD EASEMENT AND SOUTH 20 FEET FOR ROAD EASEMENT,

OF THE PUBLIC RECORDS OF SARASOTA COUNTY, FLORIDA.

and commonly known as: 1018 GUN CLUB RD, SARASOTA, FL 34232 (the "Property").

ANY PERSON CLAIMING AN INTEREST IN THE SURPLUS FROM THE SALE, IF ANY, OTHER THAN THE PROPERTY OWNER AS OF THE DATE OF THE LIS PENDENS MUST FILE A CLAIM WITHIN 60 DAYS AFTER THE SALE.

If you are a person with a disability who needs any accommodation in order to participate in this proceeding, you are entitled, at no cost to you, to the provision of certain assistance. Please contact the Sarasota County Jury Office, P.O. Box 3079, Sarasota, Florida 34230-3079, (941)861-7400, at least seven (7) days before your scheduled court appearance, or immediately upon receiving this notification if the time before the scheduled appearance is less than seven (7) days; if you are hearing or voice impaired, call 711.

GHIDOTTI | BERGER LLP  
 Attorneys for Plaintiff  
 10800 Biscayne Blvd., Suite 201  
 Miami, FL 33161  
 Telephone: (305) 501-2808  
 Facsimile: (954) 780-5578  
 By: /s/ Rebecca E. Smith  
 Jason Dugger, Esq.  
 FL Bar No.: 83813  
 Christophal Hellewell, Esq.  
 FL Bar No.: 114230  
 Anya E. Macias, Esq.  
 FL Bar No.: 0458600  
 Tara Rosenfeld, Esq.  
 FL Bar No.: 59454  
 Johanni Fernandez-Marmol, Esq.  
 FL Bar No.: 1055042  
 Jimmy Edwards, Esq.  
 FL Bar No.: 81855  
 Rebecca E. Smith, Esq.  
 FL Bar No.: 1069865  
 Spencer Gollahon, Esq.  
 FL Bar No.: 647799  
 Paris Roach, Esq.  
 FL Bar No.: 1028751  
 fcleadings@ghidottiberger.com  
 June 19, 26, 2026 26-01390S

## SECOND INSERTION

**NOTICE OF FORECLOSURE SALE PURSUANT TO CHAPTER 45 IN THE CIRCUIT COURT OF THE TWELFTH JUDICIAL CIRCUIT IN AND FOR SARASOTA COUNTY, FLORIDA**

**CASE NO.: 2023 CA 006561**  
**MTGLQ INVESTORS L.P.,**  
**Plaintiff, vs.**  
**BARBARA PIERKOWSKI, et al.,**  
**Defendant(s).**

NOTICE IS HEREBY GIVEN that sale will be made pursuant to an Order or Final Judgment. Final Judgment was awarded on August 27, 2024 in Civil Case No. 2023 CA 006561, of the Circuit Court of the Judicial Circuit in and for Sarasota County, Florida, wherein, MTGLQ INVESTORS L.P. is the Plaintiff, and BARBARA PIERKOWSKI; CITY OF NORTH PORT, FLORIDA; UNKNOWN TENANT #1 N/K/A RORY CARTER; UNKNOWN TENANT #2 N/K/A JAKOB CARTER are Defendants.

The Clerk of the Court, Karen E. Rushing will sell to the highest bidder for cash at www.sarasota.realforeclose.com on July 16, 2026 at 09:00:00 AM EST the following described real property as set forth in said Final Judgment, to wit:

LOTS 1, 2 AND 3, BLOCK 1316, 26TH ADDITION TO PORT CHARLOTTE SUBDIVISION, A SUBDIVISION TO ACCORDING TO THE PLAT THEREOF

RECORDED IN PLAT BOOK 15, PAGE 3 OF THE PUBLIC RECORDS OF SARASOTA COUNTY, FLORIDA

Any person claiming an interest in the surplus from the sale, if any, other than the property owner as of the date of the lis pendens must file a claim before the clerk reports the surplus as unclaimed.

If you are a person with a disability who needs any accommodation in order to participate in this proceeding, you are entitled, at no cost to you, to the provision of certain assistance. Please contact the Sarasota County Jury Office, P.O. Box 3079, Sarasota, Florida 34230-3079, (941)861-7400, at least seven (7) days before your scheduled court appearance, or immediately upon receiving this notification if the time before the scheduled appearance is less than seven (7) days; if you are hearing or voice impaired, call 711.

Dated this 12th day of June, 2026.

ALDRIDGE PITE, LLP  
 Attorney for Plaintiff  
 401 W. Linton Blvd.  
 Suite 202-B  
 Delray Beach, FL 33444  
 Telephone: 561-392-6391  
 Facsimile: 561-392-6965  
 By: /s/ Mola Bosland, Esq.  
 FBN: 30330  
 Primary E-Mail:  
 ServiceMail@aldridgepite.com  
 1230-173B  
 June 19, 26, 2026 26-01358S

## SECOND INSERTION

**NOTICE OF ACTION IN THE CIRCUIT COURT OF THE TWELFTH JUDICIAL CIRCUIT IN AND FOR SARASOTA COUNTY, FLORIDA CIVIL DIVISION**

**Case No.: 2026 CA 001768 SC**

**DANIELA GULLO,**  
**Plaintiff, v.**  
**JUDITH CIPOLLINA,**  
**Defendant.**

TO: JUDITH CIPOLLINA  
 Last Known Address:  
 2213 Calusa Lakes Boulevard  
 Nokomis, Florida 34275

and to all parties claiming an interest by, through, under, or against the above-named Defendant; and to all parties having or claiming to have any right, title, or interest in the real property hereinafter described.

YOU ARE NOTIFIED that an action to quiet title and to remove a cloud upon the title to the following real property in Sarasota County, Florida:

Street Address: 640 Back Nine Drive, Venice, Florida 34285.

Legal Description: LOT 932, PELICAN POINTE GOLF & COUNTRY CLUB, UNIT 6, according to the map or plat thereof, as recorded in the Public Records of Sarasota County, Florida.

has been filed against you, and you are required to serve a copy of your written defenses, if any, to it on Julia Hannah Weber, Esq., the Plaintiff's attorney,

whose address is Southron Firm, P.A., 400 N. Ashley Drive, Suite 1720, Tampa, Florida 33602, on or before July 20, 2026, and to file the original with the Clerk of the above-styled Court either before service on the Plaintiff's attorney or immediately thereafter; otherwise a default will be entered against you for the relief demanded in the Verified Complaint.

This Court has authority in this suit to enter a judgment or decree affecting the title to the real property described above which will be binding upon you.

If you are a person with a disability who needs any accommodation in order to participate in this proceeding, you are entitled, at no cost to you, to the provision of certain assistance. Please contact the Sarasota County Jury Office, P.O. Box 3079, Sarasota, Florida 34230-3079, (941)861-7400, at least seven (7) days before your scheduled court appearance, or immediately upon receiving this notification if the time before the scheduled appearance is less than seven (7) days; if you are hearing or voice impaired, call 711.

DATED: June 10, 2026  
 (SEAL) KAREN E. RUSHING  
 CLERK OF THE CIRCUIT COURT  
 SARASOTA COUNTY, FLORIDA

By: G. Kopinsky  
 Deputy Clerk  
 June 19, 26; July 3, 10, 2026 26-01377S

## SECOND INSERTION

**CLERK'S NOTICE OF SALE UNDER F.S. CHAPTER 45 IN THE CIRCUIT COURT OF THE TWELFTH JUDICIAL CIRCUIT, IN AND FOR SARASOTA COUNTY, FLORIDA**

**Case No. 2025 CA 006214 NC**  
**Honorable Judge: Hunter Carroll**  
**PLANET HOME LENDING, LLC**  
**Plaintiff, vs.**  
**ANNA GRITSAYENKO;**  
**UNKNOWN SPOUSE OF ANNA GRITSAYENKO; UNKNOWN TENANT OCCUPANT #1,**  
**UNKNOWN TENANT OCCUPANT #2; SECRETARY OF HOUSING AND URBAN DEVELOPMENT;**  
**UNITED STATES OF AMERICA;**  
**Defendants.**

NOTICE IS GIVEN that, in accordance with the AMENDED Final Judgment of Foreclosure dated June 12, 2026, in the above-styled cause, Karen E. Rushing, as the Clerk of the Circuit Court, will sell to the highest and best bidder for cash online at www.sarasota.realforeclose.com at 9:00 A.M. on July 15, 2026, the following described property:

LOT 6, LILLY'S SUBDIVISION, AS PER PLAT THEREOF RECORDED IN DEED BOOK 250, PAGE 84, OF THE PUBLIC RECORDS OF SARASOTA COUNTY, FLORIDA.  
 LESS AND EXCEPT:  
 LAND CONVEYED TO EDNA MAE WATSON IN DEED BOOK 228, PAGE 410 DESCRIBED AS FOLLOWS TO WIT:  
 BEGIN AT THE NORTHEAST CORNER OF LOT 6, LILLY'S SUBDIVISION, THENCE WEST 112 FEET FOR A POINT OF BEGINNING; THENCE SOUTH PARALLEL TO THE EAST LINE OF LOT 6, A DISTANCE OF 110 FEET TO A POINT IN SAID LOT 6; THENCE WEST PARALLEL TO THE NORTH LINE OF LOT 6, A DISTANCE OF 58 FEET; THENCE NORTH PARALLEL TO THE EAST LINE OF LOT 6, A DISTANCE OF 110 FEET TO A POINT ON THE NORTH

LINE OF LOT 6; THENCE EAST, A DISTANCE OF 58 FEET TO THE POINT OF BEGINNING.

LESS THE NORTH 12 FEET THERETO AND LESS THAT PORTION CONVEYED TO SARASOTA COUNTY FOR RIGHT OF WAY PURPOSES AND DESCRIBED IN OFFICIAL RECORDS BOOK 2888, PAGE 2599.

ALSO, LESS AND EXCEPT THE LAND DESCRIBED IN THAT CERTAIN WARRANTY DEED RECORDED IN OFFICIAL RECORDS INSTRUMENT NO. 2010083874. TAX ID # 0383120011. COMMONLY KNOWN AS: 732 HIDERBURG ST, NOKOMIS, FL 34275

ANY PERSON CLAIMING AN INTEREST IN THE SURPLUS FROM THE SALE, IF ANY, OTHER THAN THE PROPERTY OWNER AS OF THE DATE OF THE LIS PENDENS MUST FILE A CLAIM BEFORE THE CLERK REPORTS THE SURPLUS AS UNCLAIMED.

If you are a person with a disability who needs any accommodation in order to participate in this proceeding, you are entitled, at no cost to you, to the provision of certain assistance. Please contact the Sarasota County Jury Office, P.O. Box 3079, Sarasota, Florida 34230-3079, (941)861-7400, at least seven (7) days before your scheduled court appearance, or immediately upon receiving this notification if the time before the scheduled appearance is less than seven (7) days; if you are hearing or voice impaired, call 711.

Respectfully submitted this June 12, 2026.  
 /s/Matthew T. Wasinger  
 Matthew T. Wasinger, Esquire  
 Wasinger Law Office, PLLC  
 605 E. Robinson, Suite 730  
 Orlando, FL 32801  
 (407) 308-0991  
 Fla. Bar No.: 0057873  
 Attorney for Plaintiff  
 mattw@wasingerlawoffice.com  
 June 19, 26, 2026 26-01374S

## SECOND INSERTION

**RE-NOTICE OF FORECLOSURE SALE**

IN THE CIRCUIT COURT OF THE TWELFTH JUDICIAL CIRCUIT IN AND FOR SARASOTA COUNTY, FLORIDA

**CASE NO.: 2025 CA 002607 NC**  
**TH MSR HOLDINGS, LLC,**  
**Plaintiff, vs.**  
**KARA L. HAWLEY A/K/A**  
**KARA LAURYN HAWLEY, et al,**  
**Defendants.**

NOTICE OF SALE IS HEREBY GIVEN pursuant to the Order on Plaintiff's Motion to Cancel and Reschedule Foreclosure sale entered on June 11, 2026 and the Final Judgment of Foreclosure entered on February 19, 2026 in Case No.: 2025 CA 02607 NC of the Circuit Court of the Twelfth Judicial Circuit, in and for Sarasota County, Florida, wherein TH MSR HOLDINGS, LLC is Plaintiff, and, KARA L. HAWLEY A/K/A KARA LAURYN HAWLEY; RALPH CARMEN DIXON JR.; U.S. BANK NATIONAL ASSOCIATION; and GLEN OAKS MANOR HOME OWNERS ASSOCIATION, INC., are Defendants, the Office of Karen E. Rushing, Sarasota County Clerk of the Court, will sell to the highest and best bidder for cash beginning at 9:00 a.m., online at https://sarasota.realforeclose.com on the 3rd day of August, 2026, in accordance with Section 45.031, Florida Statutes, the following described property as set forth in said Final Judgment, to wit:

LOT 93, GLEN OAKS MANOR HOMES, PHASE I, A HOMES ASSOCIATION, A SUBDIVISION ACCORDING TO THE PLAT THEREOF RECORDED AT PLAT BOOK 26, PAGE 13,

IN THE PUBLIC RECORDS OF SARASOTA COUNTY, FLORIDA.

Also known as: 3752 GLEN OAKS MANOR DR, SARASOTA, FL 34232 (the "Property").

together with all existing or subsequently erected or affixed buildings, improvements and fixtures.

Any person claiming an interest in the surplus funds from the sale, if any, other than the property owner as of the date of the lis pendens, must file a claim in accordance with Florida Statutes, Section 45.031.

If you are a person with a disability who needs any accommodation in order to participate in this proceeding, you are entitled, at no cost to you, to the provision of certain assistance. Please contact the Sarasota County Jury Office, P.O. Box 3079, Sarasota, Florida 34230-3079, (941)861-7400, at least seven (7) days before your scheduled court appearance, or immediately upon receiving this notification if the time before the scheduled appearance is less than seven (7) days; if you are hearing or voice impaired, call 711.

Dated this 11th day of June, 2026  
 Sokolof Remtulla, LLP  
 Counsel for Plaintiff  
 Primary e-mail:  
 mshapanka@sokrem.com  
 Secondary e-mail:  
 pleadings@sokrem.com  
 1800 NW Corporate Blvd, Suite 302  
 Boca Raton, FL 33431  
 Telephone: (561) 507-5252  
 Facsimile: (561) 342-4842  
 By: /s/ Matthew Shapanka.  
 Matthew Shapanka, Esq.  
 Florida Bar No.: 52874  
 June 19, 26, 2026 26-01361S

## SECOND INSERTION

**NOTICE OF FORECLOSURE SALE IN THE CIRCUIT COURT OF THE TWELFTH JUDICIAL CIRCUIT IN AND FOR SARASOTA COUNTY, FLORIDA**

CIVIL DIVISION  
**CASE NO.: 2025 CC 003687 SC**  
**SONSHINE ROOFING, INC.,**  
**Plaintiff, v.**  
**JIM MESZAROS and JENNIFER MESZAROS,**  
**Defendants.**

NOTICE IS HEREBY GIVEN pursuant to a Uniform Final Judgment of Foreclosure dated April 23, 2026, and entered in Case No. 2025 CC 003687 SC, of the Circuit Court of the Twelfth Judicial Circuit in and for SARASOTA County, Florida. SONSHINE ROOFING, INC., is Plaintiff and JIM MESZAROS and JENNIFER MESZAROS, are Defendants. Karen E. Rushing, Clerk of Circuit Court for SARASOTA County Florida will sell to the highest and best bidder for cash Via the Internet at www.sarasota.realforeclosure.com at 9:00 a.m., on the 1st day of July, 2026, the following described property as set forth in said Final Judgment, to wit:

Lot 42, Block A, Heron Creek Unit 1, a subdivision according to the plat thereof, as recorded in Plat Book 40 at Page 47, of the Public Records of Sarasota County, Florida.

Any person claiming an interest in the surplus from the sale, if any, other than the property owner as of the date of the lis pendens must file a claim before the clerk reports the surplus as unclaimed.

If you are a person with a disability who needs any accommodation in order to participate in this proceeding, you are entitled, at no cost to you, to the provision of certain assistance. Please contact the Sarasota County Jury Office, P.O. Box 3079, Sarasota, Florida 34230-3079, (941)861-7400, at least seven (7) days before your scheduled court appearance, or immediately upon receiving this notification if the time before the scheduled appearance is less than seven (7) days; if you are hearing or voice impaired, call 711.

diately upon receiving this notification if the time before the scheduled appearance is less than seven (7) days; if you are hearing or voice impaired, call 711.

Si usted es una persona minusválida que necesita algún acomodamiento para poder participar en este procedimiento, usted tiene derecho, sin tener gastos propios, a que se le provea cierta ayuda. Tenga la amabilidad de ponerse en contacto Sarasota County Jury Office, P.O. Box 3079, Sarasota, Florida 34230-3079, (941)861- 8000 por lo menos 7 días antes de la cita fijada para su comparecencia en los tribunales, o inmediatamente después de recibir esta notificación si el tiempo antes de la comparecencia que se ha programado es menos de 7 días; si usted tiene discapacidad del oído o de la voz, llame al 711.

Si ou se yon moun ki enfim ki bezwen akomodasyon pou w ka patisipe nan pwosedi sa, ou kalifye san ou pa gen okenn lajan pou w peye, gen pwovizyon pou jwen kèk ed. Tanpri kontakte Sarasota County Jury Office, P.O. Box 3079, Sarasota, Florida 34230-3079, (941)861- 8000 nan 7 jou anvan dat ou gen randevou pou parèt nan tribinal la, oubyen imedyatman apre ou fin resevwa konvokasyon an si le ou gen pou parèt nan tribinal la mwens le 7 jou; si ou gen pwoblèm pou w tande oubyen pale, rele 711.

DATED: April 30, 2026  
 Respectfully submitted,  
 /s/ Jeremy D. Bailie  
 Jeremy D. Bailie (FBN 118558)  
 WEBER, CRABB & WEIN, P.A.  
 5453 Central Avenue  
 St. Petersburg, FL 33710  
 Telephone: (727) 828-9919  
 Facsimile: (727) 828-9924  
 Primary:  
 Jeremy.Bailie@webercrabb.com  
 Secondary:  
 natalie.deacon@webercrabb.com  
 Attorney for Plaintiff  
 June 19, 26, 2026 26-01360S

--- ACTIONS / SALES ---

SECOND INSERTION

**NOTICE OF ACTION**  
IN THE CIRCUIT COURT OF THE TWELFTH JUDICIAL CIRCUIT IN AND FOR SARASOTA COUNTY FLORIDA  
**Case No. 26-CA-3128**  
**EAST EUROPEAN EAGLE EQUITY LLC, a Florida limited liability company, Plaintiff, v. EAST EUROPEAN EAGLE EQUITY LTD, a foreign company, Defendant.**  
STATE OF FLORIDA  
To: EAST EUROPEAN EAGLE EQUITY LTD, a foreign company, and all parties having or claiming to have any right, title or interest in the below-described, whose residence is unknown.  
YOU ARE NOTIFIED that an action to quiet title to the following property in Sarasota County, Florida:  
Lots 40A & 41A, PLAMORE SUB, CONTAINING 521 C-SF UPLAND, 143 C-SF SUBM  
Parcel ID: 0787-15-0021  
has been filed against you and you are required to file your written defenses, if any, with the Clerk of the above Court and to serve a copy on or before July

20, 2026 upon Vestalia Aylsworth, Esq., Plaintiff's attorney, whose address is 21101 SW 198 Ave, Miami, FL 33187 and file the original with the Clerk of this Court either before service on Plaintiff's attorney or immediately thereafter; otherwise a default will be entered against you for the relief demanded in the Complaint.  
If you are a person with a disability who needs any accommodation in order to participate in this proceeding, you are entitled, at no cost to you, to the provision of certain assistance. Please contact the Sarasota County Jury Office, P.O. Box 3079, Sarasota, Florida 34230-3079, (941)861-7400, at least seven (7) days before your scheduled court appearance, or immediately upon receiving this notification if the time before the scheduled appearance is less than seven (7) days; if you are hearing or voice impaired, call 711.  
DATED this 9 day of June, 2026  
KAREN E RUSHING, CLERK  
CLERK OF THE COURT  
(SEAL) By: G. Kopinsky  
Deputy Clerk  
June 19, 26; July 3, 10, 2026  
26-01336S

SECOND INSERTION

**NOTICE OF FORECLOSURE SALE**  
IN THE CIRCUIT COURT OF THE TWELFTH JUDICIAL CIRCUIT IN AND FOR SARASOTA COUNTY, FLORIDA  
**CASE NO. 2026 CA 001308 NC**  
**GLEN OAKS MANOR HOME OWNERS ASSOCIATION, INC., a Florida Not For Profit Corporation, Plaintiff, v. STEPHEN M. HOROWITZ; DALE E. MOORE; STEPHEN M. HOROWITZ REVOCABLE LIVING TRUST DATED APRIL 5, 2017; DALE E. MOORE REVOCABLE LIVING TRUST DATED APRIL 5, 2017, Defendants.**  
Notice is hereby given pursuant to the Consent Final Judgment of Foreclosure entered on May 26, 2026 in the above-styled Case Number 2026 CA 001308 NC in the Circuit Court of Sarasota, Florida, that Karen E. Rushing, the Clerk of Court of Sarasota County Florida, shall sell the following property, in SARASOTA County, Florida, described as:  
Lot 64, GLEN OAKS MANOR HOMES, a Home Association, Phase 1, according to the plat thereof, recorded in Plat Book 26, Page 13, of the Public Records of Sarasota County, Florida.  
Property address of: 3725 Glen Oaks Manor Dr., Sarasota, FL 34232 at

public sale, to the highest and best bidder for cash, at www.sarasota.realforeclose.com, at 9:00 A.M. on JULY 7, 2026. The highest bidder shall immediately post with the Clerk, a deposit equal to 5% of the final bid. The deposit must be cash or cashier's check payable to the Clerk of Court and will be applied to the sale price at the time of final payment. Final payment must be made on or before 5:00 p.m. of the day of the sale by cash or cashier's check.  
Any person claiming an interest in the surplus from the sale, if any, other than the property owner as of the date of the lis pendens must file a claim within sixty (60) days after the sale.  
If you are a person with a disability who needs any accommodation in order to participate in this proceeding, you are entitled, at no cost to you, to the provision of certain assistance. Please contact the Sarasota County Jury Office, P.O. Box 3079, Sarasota, Florida 34230-3079, (941)861-7400, at least seven (7) days before your scheduled court appearance, or immediately upon receiving this notification if the time before the scheduled appearance is less than seven (7) days; if you are hearing or voice impaired, call 711.  
DATED this 12th day of June, 2026.  
By: Michael P. Wallach  
Michael P. Wallach, Esq.  
June 19, 26, 2026  
26-01375S

SECOND INSERTION

**NOTICE OF FORECLOSURE SALE**  
IN THE CIRCUIT COURT OF THE 12TH JUDICIAL CIRCUIT, IN AND FOR SARASOTA COUNTY, FLORIDA CIVIL DIVISION  
**CASE NO. 2024 CA 006332 NC**  
**EF MORTGAGE, LLC, Plaintiff, vs. GLOBAL STAR REAL ESTATE INVESTMENT AND COMMODITIES, LLC; GARY YOUNG A/K/A GARY ALLEN YOUNG; NIGEL ERROL LOREIHE; PANACEA OF VENICE, A CONDOMINIUM INC.; CFL BUILDING CONTRACTORS LLC, Defendant(s)**  
NOTICE IS HEREBY GIVEN pursuant to a Final Judgment of Foreclosure filed April 15, 2026 and entered in Case No. 2024 CA 006332 NC, of the Circuit Court of the 12th Judicial Circuit in and for SARASOTA County, Florida, wherein EF MORTGAGE, LLC is Plaintiff and GARY YOUNG A/K/A GARY ALLEN YOUNG; NIGEL ERROL LOREIHE; GLOBAL STAR REAL ESTATE INVESTMENT AND COMMODITIES, LLC; PANACEA OF VENICE, A CONDOMINIUM INC.; CFL BUILDING CONTRACTORS LLC; are defendants. KAREN E. RUSHING, the Clerk of the Circuit Court, will sell to the highest and best bidder for cash BY ELECTRONIC SALE AT: WWW.SARASOTA.REALFORECLOSE.COM, at 9:00 A.M., on July 14, 2026, the following described property as set forth in said Final Judgment, to wit:  
UNIT NO.1, PANACEA OF VENICE, A CONDOMINIUM F/K/A PORTOFINO OF VENICE LAND CONDOMINIUM, ACCORDING TO THE DECLARATION OF CONDOMINIUM RECORDED IN INSTRUMENT NO. 2005281485, AS AFFECTED BY CERTIFICATE OF AMENDMENT CREATED AMENDED AND RESTATED DECLARATION RECORDED IN INSTRUMENT NO. 2018125576, AND RECORDED IN CONDOMINIUM PLAT BOOK 38, PAGE 44, OF THE PUBLIC RECORDS OF SARASOTA COUNTY, FLORIDA.  
UNIT NO. 36, PANACEA OF VENICE, A CONDOMINIUM F/K/A PORTOFINO OF VENICE LAND CONDOMINIUM, ACCORDING TO THE DECLARATION OF CONDOMINIUM RECORDED IN INSTRUMENT NO. 2005281485, AS AFFECTED BY CERTIFICATE OF AMENDMENT CREATED AMENDED AND RESTATED DECLARATION RECORDED IN INSTRUMENT NO. 2018125576, AND RECORDED IN CONDOMINIUM PLAT BOOK 38, PAGE 44, OF THE PUBLIC RECORDS OF SARASOTA COUNTY, FLORIDA.  
UNIT NO. 37, PANACEA OF VENICE, A CONDOMINIUM F/K/A PORTOFINO OF VENICE LAND CONDOMINIUM, ACCORDING TO THE DECLARATION OF CONDOMINIUM RECORDED IN INSTRUMENT NO. 2005281485, AS AFFECTED BY CERTIFICATE OF AMENDMENT CREATED AMENDED AND RESTATED DECLARATION RECORDED IN INSTRUMENT NO. 2018125576, AND RECORDED IN CONDOMINIUM PLAT BOOK 38, PAGE 44, OF THE PUBLIC RECORDS OF SARASOTA COUNTY, FLORIDA.  
Any person claiming an interest in the surplus from the sale, if any, other than the property owner as of the date of the lis pendens must file a claim before the Clerk reports the surplus as unclaimed.  
If you are a person with a disability who needs any accommodation in order to participate in this proceeding, you are entitled, at no cost to you, to the provision of certain assistance. Please contact the Sarasota County Jury Office, P.O. Box 3079, Sarasota, Florida 34230-3079, (941)861-7400, at least seven (7) days before your scheduled court appearance, or immediately upon receiving this notification if the time before the scheduled appearance is less than seven (7) days; if you are hearing or voice impaired, call 711.  
DATED this 12th day of June 2026.  
Marc Granger, Esq.  
Bar. No.: 146870  
Kahane & Associates, P.A.  
1619 NW 136th Avenue, Suite D-220 Sunrise, Florida 33323  
Telephone: (954) 382-3486  
Telefacsimile: (954) 382-5380  
Designated service email: notice@kahaneandassociates.com  
File No.: 24-01352 CSLC  
June 19, 26, 2026  
26-01364S

RATION OF CONDOMINIUM RECORDED IN INSTRUMENT NO. 2005281485, AS AFFECTED BY CERTIFICATE OF AMENDMENT CREATED AMENDED AND RESTATED DECLARATION RECORDED IN INSTRUMENT NO. 2018125576, AND RECORDED IN CONDOMINIUM PLAT BOOK 38, PAGE 44, OF THE PUBLIC RECORDS OF SARASOTA COUNTY, FLORIDA.  
UNIT NO. 37, PANACEA OF VENICE, A CONDOMINIUM F/K/A PORTOFINO OF VENICE LAND CONDOMINIUM, ACCORDING TO THE DECLARATION OF CONDOMINIUM RECORDED IN INSTRUMENT NO. 2005281485, AS AFFECTED BY CERTIFICATE OF AMENDMENT CREATED AMENDED AND RESTATED DECLARATION RECORDED IN INSTRUMENT NO. 2018125576, AND RECORDED IN CONDOMINIUM PLAT BOOK 38, PAGE 44, OF THE PUBLIC RECORDS OF SARASOTA COUNTY, FLORIDA.  
Any person claiming an interest in the surplus from the sale, if any, other than the property owner as of the date of the lis pendens must file a claim before the Clerk reports the surplus as unclaimed.  
If you are a person with a disability who needs any accommodation in order to participate in this proceeding, you are entitled, at no cost to you, to the provision of certain assistance. Please contact the Sarasota County Jury Office, P.O. Box 3079, Sarasota, Florida 34230-3079, (941)861-7400, at least seven (7) days before your scheduled court appearance, or immediately upon receiving this notification if the time before the scheduled appearance is less than seven (7) days; if you are hearing or voice impaired, call 711.  
DATED this 12th day of June 2026.  
Marc Granger, Esq.  
Bar. No.: 146870  
Kahane & Associates, P.A.  
1619 NW 136th Avenue, Suite D-220 Sunrise, Florida 33323  
Telephone: (954) 382-3486  
Telefacsimile: (954) 382-5380  
Designated service email: notice@kahaneandassociates.com  
File No.: 24-01352 CSLC  
June 19, 26, 2026  
26-01364S

SECOND INSERTION

**NOTICE OF SALE**  
IN THE COUNTY COURT OF THE TWELFTH JUDICIAL CIRCUIT IN AND FOR SARASOTA COUNTY, FLORIDA  
**CASE NO. 2026-CC-002384**  
**JEFFERSON CLUB CONDOMINIUM ASSOCIATION, INC., a Florida not-for-profit corporation, Plaintiff, vs. NESTOR ALEJANDRO CARDENAS; UNKNOWN SPOUSE OF NESTOR ALEJANDRO CARDENAS; TENANT OR OCCUPANT #1, AS UNKNOWN TENANT OR OCCUPANT IN POSSESSION; TENANT OR OCCUPANT #2, AS UNKNOWN TENANT OR OCCUPANT IN POSSESSION; GUY BROTHERS ROOFING AND SIDING, INC, a Florida for-profit corporation, Defendants.**  
NOTICE IS HEREBY GIVEN pursuant to the Summary Final Judgment of Foreclosure entered on June 15, 2026, and entered in Case No. 2026 CC 002384 NC, in the County Court of the Twelfth Judicial Circuit in and for Sarasota County, Florida, wherein JEFFERSON CLUB CONDOMINIUM ASSOCIATION, INC., a Florida not-for-profit corporation is the Plaintiff and NESTOR ALEJANDRO CARDENAS; FLORA VALARCE, AS TENANT OR OCCUPANT #1; and GUY BROTHERS ROOFING AND SIDING, INC. are Defendants, KAREN E. RUSHING, Sarasota County Clerk of Courts will sell to the highest and best bidder for cash at www.sarasota.realforeclose.com at 9:00 am on July 30, 2026, the following described property set forth in said Final Judgment, to wit:  
Unit 1-F a/k/a Unit 1, Building "F", JEFFERSON CLUB, a Condominium, according to the Declaration of Condominium recorded in Official Records Book 1325, Pages 1840 and amendments thereto, and as per plat thereof, recorded in Condominium Book 13, Page 7, and amendments thereto, of the Public Records of Sarasota County, Florida; together with an undivided interest in the common elements appurtenant thereto.  
With an address of 500 N. Jefferson Ave. Apartment F1, Sarasota, FL 34237.  
Any person or entity claiming an interest in the surplus, if any, resulting from the Foreclosure Sale, other than the property owner as of the date of the Lis Pendens, must file a claim with the Clerk no later than the date that the Clerk reports the funds are unclaimed. If you fail to file a claim, you will not be entitled to any remaining funds.

If the sale is set aside, the Purchaser may be entitled to only a return of the sale deposit less any applicable fees and costs and shall have no other records against the Plaintiff, Defendants or their attorneys.  
IF THIS PROPERTY IS SOLD AT PUBLIC AUCTION, THERE MAY BE ADDITIONAL MONEY FROM THE SALE AFTER PAYMENT OF PERSONS WHO ARE ENTITLED TO BE PAID FROM THE SALE PROCEEDS PURSUANT TO THIS FINAL JUDGMENT.  
IF YOU ARE THE PROPERTY OWNER, YOU MAY CLAIM THESE FUNDS YOURSELF. YOU ARE NOT REQUIRED TO HAVE A LAWYER OR ANY OTHER REPRESENTATION AND YOU DO NOT HAVE TO ASSIGN YOUR RIGHTS TO ANYONE ELSE IN ORDER FOR YOU TO CLAIM ANY MONEY TO WHICH YOU ARE ENTITLED. PLEASE CHECK WITH THE CLERK OF THE COURT OF SARASOTA COUNTY, WITHIN TEN (10) DAYS AFTER THE SALE TO SEE IF THERE IS ADDITIONAL MONEY FROM THE FORECLOSURE SALE THAT THE CLERK HAS IN THE REGISTRY OF THE COURT.  
IF YOU ARE A SUBORDINATE LIENHOLDER CLAIMING A RIGHT TO FUNDS REMAINING AFTER THE SALE, IF ANY, YOU MUST FILE A CLAIM WITH THE CLERK NO LATER THAN THE DATE THAT THE CLERK REPORTS THE FUNDS AS UNCLAIMED. IF YOU FAIL TO FILE A TIMELY CLAIM, YOU WILL NOT BE ENTITLED TO ANY REMAINING FUNDS.  
If you are a person with a disability who needs any accommodation in order to participate in this proceeding, you are entitled, at no cost to you, to the provision of certain assistance. Please contact the Sarasota County Jury Office, P.O. Box 3079, Sarasota, Florida 34230-3079, (941)861-7400, at least seven (7) days before your scheduled court appearance, or immediately upon receiving this notification if the time before the scheduled appearance is less than seven (7) days; if you are hearing or voice impaired, call 711.  
DATED THIS 16 DAY OF JUNE, 2026.  
Michelle A. Rowe, ESQUIRE  
Florida Bar No. 036605  
The Law Offices of  
Lobeck & Rowe, P.A.  
2033 Main Street, Suite 403  
Sarasota, Florida 34237-6063  
(941) 955-5622  
Email: mrowe@lobeckrowe.com  
Secondary: carrieta@lobeckrowe.com  
Attorneys for Plaintiff  
June 19, 26, 2026  
26-01404S

SECOND INSERTION

**NOTICE OF FORECLOSURE SALE**  
IN THE CIRCUIT COURT OF THE 12TH JUDICIAL CIRCUIT, IN AND FOR SARASOTA COUNTY, FLORIDA CIVIL DIVISION  
**CASE NO. 2024 CA 006290 NC**  
**EF MORTGAGE, LLC, Plaintiff, vs. GLOBAL STAR REAL ESTATE INVESTMENT AND COMMODITIES, LLC; GARY YOUNG A/K/A GARY ALLEN YOUNG; NIGEL ERROL LOREIHE; PANACEA OF VENICE, A CONDOMINIUM INC.; CFL BUILDING CONTRACTORS LLC, Defendant(s)**  
NOTICE IS HEREBY GIVEN pursuant to a Consent Final Judgment of Mortgage Foreclosure filed April 15, 2026 and entered in Case No. 2024 CA 006290 NC, of the Circuit Court of the 12th Judicial Circuit in and for SARASOTA County, Florida, wherein EF MORTGAGE, LLC is Plaintiff and GARY YOUNG A/K/A GARY ALLEN YOUNG; NIGEL ERROL LOREIHE; GLOBAL STAR REAL ESTATE INVESTMENT AND COMMODITIES, LLC; PANACEA OF VENICE, A CONDOMINIUM INC.; CFL BUILDING CONTRACTORS LLC; are defendants. KAREN E. RUSHING, the Clerk of the Circuit Court, will sell to the highest and best bidder for cash BY ELECTRONIC SALE AT: WWW.SARASOTA.REALFORECLOSE.COM, at 9:00 A.M., on July 14, 2026, the following described property as set forth in said Final Judgment, to wit:  
UNIT NO. 19, PANACEA OF VENICE, A CONDOMINIUM F/K/A PORTOFINO OF VENICE, LAND CONDOMINIUM, ACCORDING TO THE DECLARATION OF CONDOMINIUM RECORDED IN INSTRUMENT NO. 2005281485, AS AFFECTED BY CERTIFICATE OF AMENDMENT CREATED AMENDED AND RESTATED DECLARATION RECORDED IN INSTRUMENT NO. 2018125576, AND RECORDED IN CONDOMINIUM PLAT BOOK 38, PAGE 44, OF THE PUBLIC RECORDS OF SARASOTA COUNTY, FLORIDA.  
UNIT NO. 24, PANACEA OF VENICE, A CONDOMINIUM F/K/A PORTOFINO OF VENICE, LAND CONDOMINIUM, ACCORDING TO THE DECLARATION OF CONDOMINIUM RECORDED IN INSTRUMENT NO. 2005281485, AS AFFECTED BY CERTIFICATE OF AMENDMENT CREATED AMENDED AND RESTATED DECLARATION RECORDED IN INSTRUMENT NO. 2018125576, AND RECORDED IN CONDOMINIUM PLAT BOOK 38, PAGE 44, OF THE PUBLIC RECORDS OF SARASOTA COUNTY, FLORIDA.  
Any person claiming an interest in the surplus from the sale, if any, other than the property owner as of the date of the lis pendens must file a claim before the Clerk reports the surplus as unclaimed.  
If you are a person with a disability who needs any accommodation in order to participate in this proceeding, you are entitled, at no cost to you, to the provision of certain assistance. Please contact the Sarasota County Jury Office, P.O. Box 3079, Sarasota, Florida 34230-3079, (941)861-7400, at least seven (7) days before your scheduled court appearance, or immediately upon receiving this notification if the time before the scheduled appearance is less than seven (7) days; if you are hearing or voice impaired, call 711.  
DATED this 12th day of June 2026.  
Marc Granger, Esq.  
Bar. No.: 146870  
Kahane & Associates, P.A.  
1619 NW 136th Avenue, Suite D-220 Sunrise, Florida 33323  
Telephone: (954) 382-3486  
Telefacsimile: (954) 382-5380  
Designated service email: notice@kahaneandassociates.com  
File No.: 24-01351 CSLC  
June 19, 26, 2026  
26-01363S

ACCORDING TO THE DECLARATION OF CONDOMINIUM RECORDED IN INSTRUMENT NO. 2005281485, AS AFFECTED BY CERTIFICATE OF AMENDMENT CREATED AMENDED AND RESTATED DECLARATION RECORDED IN INSTRUMENT NO. 2018125576, AND RECORDED IN CONDOMINIUM PLAT BOOK 38, PAGE 44, OF THE PUBLIC RECORDS OF SARASOTA COUNTY, FLORIDA.  
UNIT NO. 27, PANACEA OF VENICE, A CONDOMINIUM F/K/A PORTOFINO OF VENICE, LAND CONDOMINIUM, ACCORDING TO THE DECLARATION OF CONDOMINIUM RECORDED IN INSTRUMENT NO. 2005281485, AS AFFECTED BY CERTIFICATE OF AMENDMENT CREATED AMENDED AND RESTATED DECLARATION RECORDED IN INSTRUMENT NO. 2018125576, AND RECORDED IN CONDOMINIUM PLAT BOOK 38, PAGE 44, OF THE PUBLIC RECORDS OF SARASOTA COUNTY, FLORIDA.  
Any person claiming an interest in the surplus from the sale, if any, other than the property owner as of the date of the lis pendens must file a claim before the Clerk reports the surplus as unclaimed.  
If you are a person with a disability who needs any accommodation in order to participate in this proceeding, you are entitled, at no cost to you, to the provision of certain assistance. Please contact the Sarasota County Jury Office, P.O. Box 3079, Sarasota, Florida 34230-3079, (941)861-7400, at least seven (7) days before your scheduled court appearance, or immediately upon receiving this notification if the time before the scheduled appearance is less than seven (7) days; if you are hearing or voice impaired, call 711.  
DATED this 12th day of June 2026.  
Marc Granger, Esq.  
Bar. No.: 146870  
Kahane & Associates, P.A.  
1619 NW 136th Avenue, Suite D-220 Sunrise, Florida 33323  
Telephone: (954) 382-3486  
Telefacsimile: (954) 382-5380  
Designated service email: notice@kahaneandassociates.com  
File No.: 24-01351 CSLC  
June 19, 26, 2026  
26-01363S

SECOND INSERTION

**NOTICE OF FORECLOSURE SALE**  
IN THE CIRCUIT COURT OF THE 12TH JUDICIAL CIRCUIT, IN AND FOR SARASOTA COUNTY, FLORIDA CIVIL DIVISION  
**CASE NO. 2024 CA 006330 NC**  
**EF MORTGAGE, LLC, Plaintiff, vs. GLOBAL STAR REAL ESTATE INVESTMENT AND COMMODITIES, LLC; GARY YOUNG A/K/A GARY ALLEN YOUNG; NIGEL ERROL LOREIHE; PANACEA OF VENICE, A CONDOMINIUM INC.; CFL BUILDING CONTRACTORS LLC, Defendant(s)**  
NOTICE IS HEREBY GIVEN pursuant to a Final Judgment of Foreclosure filed April 15, 2026 and entered in Case No. 2024 CA 006330 NC, of the Circuit Court of the 12th Judicial Circuit in and for SARASOTA County, Florida, wherein EF MORTGAGE LLC is Plaintiff and GARY YOUNG A/K/A GARY ALLEN YOUNG; NIGEL ERROL LOREIHE; GLOBAL STAR REAL ESTATE INVESTMENT AND COMMODITIES, LLC; PANACEA OF VENICE, A CONDOMINIUM INC.; CFL BUILDING CONTRACTORS LLC; are defendants. KAREN E. RUSHING, the Clerk of the Circuit Court, will sell to the highest and best bidder for cash BY ELECTRONIC SALE AT: WWW.SARASOTA.REALFORECLOSE.COM, at 9:00 A.M., on July 14, 2026, the following described property as set forth in said Final Judgment, to wit:  
UNIT NO. 11, PANACEA OF VENICE, A CONDOMINIUM F/K/A PORTOFINO OF VENICE LAND CONDOMINIUM, ACCORDING TO THE DECLARATION OF CONDOMINIUM RECORDED IN INSTRUMENT NO. 2005281485, AS AFFECTED BY CERTIFICATE OF AMENDMENT CREATED AMENDED AND RESTATED DECLARATION RECORDED IN INSTRUMENT NO. 2018125576, AND RECORDED IN CONDOMINIUM PLAT BOOK 38, PAGE 44, OF THE PUBLIC RECORDS OF SARASOTA COUNTY, FLORIDA.  
UNIT NO. 2, PANACEA OF VENICE, A CONDOMINIUM F/K/A PORTOFINO OF VENICE LAND CONDOMINIUM, ACCORDING TO THE DECLARATION OF CONDOMINIUM RECORDED IN INSTRUMENT NO. 2005281485, AS AFFECTED BY CERTIFICATE OF AMENDMENT CREATED AMENDED AND RESTATED DECLARATION RECORDED IN INSTRUMENT NO. 2018125576, AND RECORDED IN CONDOMINIUM PLAT BOOK 38, PAGE 44, OF THE PUBLIC RECORDS OF SARASOTA COUNTY, FLORIDA.  
UNIT NO. 2, PANACEA OF VENICE, A CONDOMINIUM F/K/A PORTOFINO OF VENICE LAND CONDOMINIUM, ACCORDING TO THE DECLARATION OF CONDOMINIUM RECORDED IN INSTRUMENT NO. 2005281485, AS AFFECTED BY CERTIFICATE OF AMENDMENT CREATED AMENDED AND RESTATED DECLARATION RECORDED IN INSTRUMENT NO. 2018125576, AND RECORDED IN CONDOMINIUM PLAT BOOK 38, PAGE 44, OF THE PUBLIC RECORDS OF SARASOTA COUNTY, FLORIDA.  
UNIT NO. 2, PANACEA OF VENICE, A CONDOMINIUM F/K/A PORTOFINO OF VENICE LAND CONDOMINIUM, ACCORDING TO THE DECLARATION OF CONDOMINIUM RECORDED IN INSTRUMENT NO. 2005281485, AS AFFECTED BY CERTIFICATE OF AMENDMENT CREATED AMENDED AND RESTATED DECLARATION RECORDED IN INSTRUMENT NO. 2018125576, AND RECORDED IN CONDOMINIUM PLAT BOOK 38, PAGE 44, OF THE PUBLIC RECORDS OF SARASOTA COUNTY, FLORIDA.  
UNIT NO. 2, PANACEA OF VENICE, A CONDOMINIUM F/K/A PORTOFINO OF VENICE LAND CONDOMINIUM, ACCORDING TO THE DECLARATION OF CONDOMINIUM RECORDED IN INSTRUMENT NO. 2005281485, AS AFFECTED BY CERTIFICATE OF AMENDMENT CREATED AMENDED AND RESTATED DECLARATION RECORDED IN INSTRUMENT NO. 2018125576, AND RECORDED IN CONDOMINIUM PLAT BOOK 38, PAGE 44, OF THE PUBLIC RECORDS OF SARASOTA COUNTY, FLORIDA.  
UNIT NO. 2, PANACEA OF VENICE, A CONDOMINIUM F/K/A PORTOFINO OF VENICE LAND CONDOMINIUM, ACCORDING TO THE DECLARATION OF CONDOMINIUM RECORDED IN INSTRUMENT NO. 2005281485, AS AFFECTED BY CERTIFICATE OF AMENDMENT CREATED AMENDED AND RESTATED DECLARATION RECORDED IN INSTRUMENT NO. 2018125576, AND RECORDED IN CONDOMINIUM PLAT BOOK 38, PAGE 44, OF THE PUBLIC RECORDS OF SARASOTA COUNTY, FLORIDA.  
UNIT NO. 2, PANACEA OF VENICE, A CONDOMINIUM F/K/A PORTOFINO OF VENICE LAND CONDOMINIUM, ACCORDING TO THE DECLARATION OF CONDOMINIUM RECORDED IN INSTRUMENT NO. 2005281485, AS AFFECTED BY CERTIFICATE OF AMENDMENT CREATED AMENDED AND RESTATED DECLARATION RECORDED IN INSTRUMENT NO. 2018125576, AND RECORDED IN CONDOMINIUM PLAT BOOK 38, PAGE 44, OF THE PUBLIC RECORDS OF SARASOTA COUNTY, FLORIDA.  
UNIT NO. 2, PANACEA OF VENICE, A CONDOMINIUM F/K/A PORTOFINO OF VENICE LAND CONDOMINIUM, ACCORDING TO THE DECLARATION OF CONDOMINIUM RECORDED IN INSTRUMENT NO. 2005281485, AS AFFECTED BY CERTIFICATE OF AMENDMENT CREATED AMENDED AND RESTATED DECLARATION RECORDED IN INSTRUMENT NO. 2018125576, AND RECORDED IN CONDOMINIUM PLAT BOOK 38, PAGE 44, OF THE PUBLIC RECORDS OF SARASOTA COUNTY, FLORIDA.  
UNIT NO. 2, PANACEA OF VENICE, A CONDOMINIUM F/K/A PORTOFINO OF VENICE LAND CONDOMINIUM, ACCORDING TO THE DECLARATION OF CONDOMINIUM RECORDED IN INSTRUMENT NO. 2005281485, AS AFFECTED BY CERTIFICATE OF AMENDMENT CREATED AMENDED AND RESTATED DECLARATION RECORDED IN INSTRUMENT NO. 2018125576, AND RECORDED IN CONDOMINIUM PLAT BOOK 38, PAGE 44, OF THE PUBLIC RECORDS OF SARASOTA COUNTY, FLORIDA.  
UNIT NO. 2, PANACEA OF VENICE, A CONDOMINIUM F/K/A PORTOFINO OF VENICE LAND CONDOMINIUM, ACCORDING TO THE DECLARATION OF CONDOMINIUM RECORDED IN INSTRUMENT NO. 2005281485, AS AFFECTED BY CERTIFICATE OF AMENDMENT CREATED AMENDED AND RESTATED DECLARATION RECORDED IN INSTRUMENT NO. 2018125576, AND RECORDED IN CONDOMINIUM PLAT BOOK 38, PAGE 44, OF THE PUBLIC RECORDS OF SARASOTA COUNTY, FLORIDA.  
UNIT NO. 2, PANACEA OF VENICE, A CONDOMINIUM F/K/A PORTOFINO OF VENICE LAND CONDOMINIUM, ACCORDING TO THE DECLARATION OF CONDOMINIUM RECORDED IN INSTRUMENT NO. 2005281485, AS AFFECTED BY CERTIFICATE OF AMENDMENT CREATED AMENDED AND RESTATED DECLARATION RECORDED IN INSTRUMENT NO. 2018125576, AND RECORDED IN CONDOMINIUM PLAT BOOK 38, PAGE 44, OF THE PUBLIC RECORDS OF SARASOTA COUNTY, FLORIDA.  
UNIT NO. 2, PANACEA OF VENICE, A CONDOMINIUM F/K/A PORTOFINO OF VENICE LAND CONDOMINIUM, ACCORDING TO THE DECLARATION OF CONDOMINIUM RECORDED IN INSTRUMENT NO. 2005281485, AS AFFECTED BY CERTIFICATE OF AMENDMENT CREATED AMENDED AND RESTATED DECLARATION RECORDED IN INSTRUMENT NO. 2018125576, AND RECORDED IN CONDOMINIUM PLAT BOOK 38, PAGE 44, OF THE PUBLIC RECORDS OF SARASOTA COUNTY, FLORIDA.  
UNIT NO. 2, PANACEA OF VENICE, A CONDOMINIUM F/K/A PORTOFINO OF VENICE LAND CONDOMINIUM, ACCORDING TO THE DECLARATION OF CONDOMINIUM RECORDED IN INSTRUMENT NO. 2005281485, AS AFFECTED BY CERTIFICATE OF AMENDMENT CREATED AMENDED AND RESTATED DECLARATION RECORDED IN INSTRUMENT NO. 2018125576, AND RECORDED IN CONDOMINIUM PLAT BOOK 38, PAGE 44, OF THE PUBLIC RECORDS OF SARASOTA COUNTY, FLORIDA.  
UNIT NO. 2, PANACEA OF VENICE, A CONDOMINIUM F/K/A PORTOFINO OF VENICE LAND CONDOMINIUM, ACCORDING TO THE DECLARATION OF CONDOMINIUM RECORDED IN INSTRUMENT NO. 2005281485, AS AFFECTED BY CERTIFICATE OF AMENDMENT CREATED AMENDED AND RESTATED DECLARATION RECORDED IN INSTRUMENT NO. 2018125576, AND RECORDED IN CONDOMINIUM PLAT BOOK 38, PAGE 44, OF THE PUBLIC RECORDS OF SARASOTA COUNTY, FLORIDA.  
UNIT NO. 2, PANACEA OF VENICE, A CONDOMINIUM F/K/A PORTOFINO OF VENICE LAND CONDOMINIUM, ACCORDING TO THE DECLARATION OF CONDOMINIUM RECORDED IN INSTRUMENT NO. 2005281485, AS AFFECTED BY CERTIFICATE OF AMENDMENT CREATED AMENDED AND RESTATED DECLARATION RECORDED IN INSTRUMENT NO. 2018125576, AND RECORDED IN CONDOMINIUM PLAT BOOK 38, PAGE 44, OF THE PUBLIC RECORDS OF SARASOTA COUNTY, FLORIDA.  
UNIT NO. 2, PANACEA OF VENICE, A CONDOMINIUM F/K/A PORTOFINO OF VENICE LAND CONDOMINIUM, ACCORDING TO THE DECLARATION OF CONDOMINIUM RECORDED IN INSTRUMENT NO. 2005281485, AS AFFECTED BY CERTIFICATE OF AMENDMENT CREATED AMENDED AND RESTATED DECLARATION RECORDED IN INSTRUMENT NO. 2018125576, AND RECORDED IN CONDOMINIUM PLAT BOOK 38, PAGE 44, OF THE PUBLIC RECORDS OF SARASOTA COUNTY, FLORIDA.  
UNIT NO. 2, PANACEA OF VENICE, A CONDOMINIUM F/K/A PORTOFINO OF VENICE LAND CONDOMINIUM, ACCORDING TO THE DECLARATION OF CONDOMINIUM RECORDED IN INSTRUMENT NO. 2005281485, AS AFFECTED BY CERTIFICATE OF AMENDMENT CREATED AMENDED AND RESTATED DECLARATION RECORDED IN INSTRUMENT NO. 2018125576, AND RECORDED IN CONDOMINIUM PLAT BOOK 38, PAGE 44, OF THE PUBLIC RECORDS OF SARASOTA COUNTY, FLORIDA.  
UNIT NO. 2, PANACEA OF VENICE, A CONDOMINIUM F/K/A PORTOFINO OF VENICE LAND CONDOMINIUM, ACCORDING TO THE DECLARATION OF CONDOMINIUM RECORDED IN INSTRUMENT NO. 2005281485, AS AFFECTED BY CERTIFICATE OF AMENDMENT CREATED AMENDED AND RESTATED DECLARATION RECORDED IN INSTRUMENT NO. 2018125576, AND RECORDED IN CONDOMINIUM PLAT BOOK 38, PAGE 44, OF THE PUBLIC RECORDS OF SARASOTA COUNTY, FLORIDA.  
UNIT NO. 2, PANACEA OF VENICE, A CONDOMINIUM F/K/A PORTOFINO OF VENICE LAND CONDOMINIUM, ACCORDING TO THE DECLARATION OF CONDOMINIUM RECORDED IN INSTRUMENT NO. 2005281485, AS AFFECTED BY CERTIFICATE OF AMENDMENT CREATED AMENDED AND RESTATED DECLARATION RECORDED IN INSTRUMENT NO. 2018125576, AND RECORDED IN CONDOMINIUM PLAT BOOK 38, PAGE 44, OF THE PUBLIC RECORDS OF SARASOTA COUNTY, FLORIDA.  
UNIT NO. 2, PANACEA OF VENICE, A CONDOMINIUM F/K/A PORTOFINO OF VENICE LAND CONDOMINIUM, ACCORDING TO THE DECLARATION OF CONDOMINIUM RECORDED IN INSTRUMENT NO. 2005281485, AS AFFECTED BY CERTIFICATE OF AMENDMENT CREATED AMENDED AND RESTATED DECLARATION RECORDED IN INSTRUMENT NO. 2018125576, AND RECORDED IN CONDOMINIUM PLAT BOOK 38, PAGE 44, OF THE PUBLIC RECORDS OF SARASOTA COUNTY, FLORIDA.  
UNIT NO. 2, PANACEA OF VENICE, A CONDOMINIUM F/K/A PORTOFINO OF VENICE LAND CONDOMINIUM, ACCORDING TO THE DECLARATION OF CONDOMINIUM RECORDED IN INSTRUMENT NO. 2005281485, AS AFFECTED BY CERTIFICATE OF AMENDMENT CREATED AMENDED AND RESTATED DECLARATION RECORDED IN INSTRUMENT NO. 2018125576, AND RECORDED IN CONDOMINIUM PLAT BOOK 38, PAGE 44, OF THE PUBLIC RECORDS OF SARASOTA COUNTY, FLORIDA.  
UNIT NO. 2, PANACEA OF VENICE, A CONDOMINIUM F/K/A PORTOFINO OF VENICE LAND CONDOMINIUM, ACCORDING TO THE DECLARATION OF CONDOMINIUM RECORDED IN INSTRUMENT NO. 2005281485, AS AFFECTED BY CERTIFICATE OF AMENDMENT CREATED AMENDED AND RESTATED DECLARATION RECORDED IN INSTRUMENT NO. 2018125576, AND RECORDED IN CONDOMINIUM PLAT BOOK 38, PAGE 44, OF THE PUBLIC RECORDS OF SARASOTA COUNTY, FLORIDA.  
UNIT NO. 2, PANACEA OF VENICE, A CONDOMINIUM F/K/A PORTOFINO OF VENICE LAND CONDOMINIUM, ACCORDING TO THE DECLARATION OF CONDOMINIUM RECORDED IN INSTRUMENT NO. 2005281485, AS AFFECTED BY CERTIFICATE OF AMENDMENT CREATED AMENDED AND RESTATED DECLARATION RECORDED IN INSTRUMENT NO. 2018125576, AND RECORDED IN CONDOMINIUM PLAT BOOK 38, PAGE 44, OF THE PUBLIC RECORDS OF SARASOTA COUNTY, FLORIDA.  
UNIT NO. 2, PANACEA OF VENICE, A CONDOMINIUM F/K/A PORTOFINO OF VENICE LAND CONDOMINIUM, ACCORDING TO THE DECLARATION OF CONDOMINIUM RECORDED IN INSTRUMENT NO. 2005281485, AS AFFECTED BY CERTIFICATE OF AMENDMENT CREATED AMENDED AND RESTATED DECLARATION RECORDED IN INSTRUMENT NO. 2018125576, AND RECORDED IN CONDOMINIUM PLAT BOOK 38, PAGE 44, OF THE PUBLIC RECORDS OF SARASOTA COUNTY, FLORIDA.  
UNIT NO. 2, PANACEA OF VENICE, A CONDOMINIUM F/K/A PORTOFINO OF VENICE LAND CONDOMINIUM, ACCORDING TO THE DECLARATION OF CONDOMINIUM RECORDED IN INSTRUMENT NO. 2005281485, AS AFFECTED BY CERTIFICATE OF AMENDMENT CREATED AMENDED AND RESTATED DECLARATION RECORDED IN INSTRUMENT NO. 2018125576, AND RECORDED IN CONDOMINIUM PLAT BOOK 38, PAGE 44, OF THE PUBLIC RECORDS OF SARASOTA COUNTY, FLORIDA.  
UNIT NO. 2, PANACEA OF VENICE, A CONDOMINIUM F/K/A PORTOFINO OF VENICE LAND CONDOMINIUM, ACCORDING TO THE DECLARATION OF CONDOMINIUM RECORDED IN INSTRUMENT NO. 2005281485, AS AFFECTED BY CERTIFICATE OF AMENDMENT CREATED AMENDED AND RESTATED DECLARATION RECORDED IN INSTRUMENT NO. 2018125576, AND RECORDED IN CONDOMINIUM PLAT BOOK 38, PAGE 44, OF THE PUBLIC RECORDS OF SARASOTA COUNTY, FLORIDA.  
UNIT NO. 2, PANACEA OF VENICE, A CONDOMINIUM F/K/A PORTOFINO OF VENICE LAND CONDOMINIUM, ACCORDING TO THE DECLARATION OF CONDOMINIUM RECORDED IN INSTRUMENT NO. 2005281485, AS AFFECTED BY CERTIFICATE OF AMENDMENT CREATED AMENDED AND RESTATED DECLARATION RECORDED IN INSTRUMENT NO. 2018125576, AND RECORDED IN CONDOMINIUM PLAT BOOK 38, PAGE 44, OF THE PUBLIC RECORDS OF SARASOTA COUNTY, FLORIDA.  
UNIT NO. 2, PANACEA OF VENICE, A CONDOMINIUM F/K/A PORTOFINO OF VENICE LAND CONDOMINIUM, ACCORDING TO THE DECLARATION OF CONDOMINIUM RECORDED IN INSTRUMENT NO. 2005281485, AS AFFECTED BY CERTIFICATE OF AMENDMENT CREATED AMENDED AND RESTATED DECLARATION RECORDED IN INSTRUMENT NO. 2018125576, AND RECORDED IN CONDOMINIUM PLAT BOOK 38, PAGE 44, OF THE PUBLIC RECORDS OF SARASOTA COUNTY, FLORIDA.  
UNIT NO. 2, PANACEA OF VENICE, A CONDOMINIUM F/K/A PORTOFINO OF VENICE LAND CONDOMINIUM, ACCORDING TO THE DECLARATION OF CONDOMINIUM RECORDED IN INSTRUMENT NO. 2005281485, AS AFFECTED BY CERTIFICATE OF AMENDMENT CREATED AMENDED AND RESTATED DECLARATION RECORDED IN INSTRUMENT NO. 2018125576, AND RECORDED IN CONDOMINIUM PLAT BOOK 38, PAGE 44, OF THE PUBLIC RECORDS OF SARASOTA COUNTY, FLORIDA.  
UNIT NO. 2, PANACEA OF VENICE, A CONDOMINIUM F/K/A PORTOFINO OF VENICE LAND CONDOMINIUM, ACCORDING TO THE DECLARATION OF CONDOMINIUM RECORDED IN INSTRUMENT NO. 2005281485, AS AFFECTED BY CERTIFICATE OF AMENDMENT CREATED AMENDED AND RESTATED DECLARATION RECORDED IN INSTRUMENT NO. 2018125576, AND RECORDED IN CONDOMINIUM PLAT BOOK 38, PAGE 44, OF THE PUBLIC RECORDS OF SARASOTA COUNTY, FLORIDA.  
UNIT NO. 2, PANACEA OF VENICE, A CONDOMINIUM F/K/A PORTOFINO OF VENICE LAND CONDOMINIUM, ACCORDING TO THE DECLARATION OF CONDOMINIUM RECORDED IN INSTRUMENT NO. 2005281485, AS AFFECTED BY CERTIFICATE OF AMENDMENT CREATED AMENDED AND RESTATED DECLARATION RECORDED IN INSTRUMENT NO. 2018125576, AND RECORDED IN CONDOMINIUM PLAT BOOK 38, PAGE 44, OF THE PUBLIC RECORDS OF SARASOTA COUNTY, FLORIDA.  
UNIT NO. 2, PANACEA OF VENICE, A CONDOMINIUM F/K/A PORTOFINO OF VENICE LAND CONDOMINIUM, ACCORDING TO THE DECLARATION OF CONDOMINIUM RECORDED IN INSTRUMENT NO. 2005281485, AS AFFECTED BY CERTIFICATE OF AMENDMENT CREATED AMENDED AND RESTATED DECLARATION RECORDED IN INSTRUMENT NO. 2018125576, AND RECORDED IN CONDOMINIUM PLAT BOOK 38, PAGE 44, OF THE PUBLIC RECORDS OF SARASOTA COUNTY, FLORIDA.  
UNIT NO. 2, PANACEA OF VENICE, A CONDOMINIUM F/K/A PORTOFINO OF VENICE LAND CONDOMINIUM, ACCORDING TO THE DECLARATION OF CONDOMINIUM RECORDED IN INSTRUMENT NO. 2005281485, AS AFFECTED BY CERTIFICATE OF AMENDMENT CREATED AMENDED AND RESTATED DECLARATION RECORDED IN INSTRUMENT NO. 2018125576, AND RECORDED IN CONDOMINIUM PLAT BOOK 38, PAGE 44, OF THE PUBLIC RECORDS OF SARASOTA COUNTY, FLORIDA.  
UNIT NO. 2, PANACEA OF VENICE, A CONDOMINIUM F/K/A PORTOFINO OF VENICE LAND CONDOMINIUM, ACCORDING TO THE DECLARATION OF CONDOMINIUM RECORDED IN INSTRUMENT NO. 2005281485, AS AFFECTED BY CERTIFICATE OF AMENDMENT CREATED AMENDED AND RESTATED DECLARATION RECORDED IN INSTRUMENT NO. 2018125576, AND RECORDED IN CONDOMINIUM PLAT BOOK 38, PAGE 44, OF THE PUBLIC RECORDS OF SARASOTA COUNTY, FLORIDA.  
UNIT NO. 2, PANACEA OF VENICE, A CONDOMINIUM F/K/A PORTOFINO OF VENICE LAND CONDOMINIUM, ACCORDING TO THE DECLARATION OF CONDOMINIUM RECORDED IN INSTRUMENT NO. 2005281485, AS AFFECTED BY CERTIFICATE OF AMENDMENT CREATED AMENDED AND RESTATED DECLARATION RECORDED IN INSTRUMENT NO. 2018125576, AND RECORDED IN CONDOMINIUM PLAT BOOK 38, PAGE 44, OF THE PUBLIC RECORDS OF SARASOTA COUNTY, FLORIDA.  
UNIT NO. 2, PANACEA OF VENICE, A CONDOMINIUM F/K/A PORTOFINO OF VENICE LAND CONDOMINIUM, ACCORDING TO THE DECLARATION OF CONDOMINIUM RECORDED IN INSTRUMENT NO. 2005281485, AS AFFECTED BY CERTIFICATE OF AMENDMENT CREATED AMENDED AND RESTATED DECLARATION RECORDED IN INSTRUMENT NO. 2018125576, AND RECORDED IN CONDOMINIUM PLAT BOOK 38, PAGE 44, OF THE PUBLIC RECORDS OF SARASOTA COUNTY, FLORIDA.  
UNIT NO. 2, PANACEA OF VENICE, A CONDOMINIUM F/K/A PORTOFINO OF VENICE LAND CONDOMINIUM, ACCORDING TO THE DECLARATION OF CONDOMINIUM RECORDED IN INSTRUMENT NO. 2005281485, AS AFFECTED BY CERTIFICATE OF AMENDMENT CREATED AMENDED AND RESTATED DECLARATION RECORDED IN INSTRUMENT NO. 2018125576, AND RECORDED

## --- ACTIONS / SALES ---

## SECOND INSERTION

**NOTICE OF SALE PURSUANT TO CHAPTER 45**  
IN THE CIRCUIT COURT OF THE TWELFTH JUDICIAL CIRCUIT IN AND FOR SARASOTA COUNTY, FLORIDA  
CIVIL ACTION  
CASE NO.: 2025 CA 004566 NC  
DIVISION: C

**CARRINGTON MORTGAGE SERVICES, LLC,**  
Plaintiff, vs.  
**BRYANNA MORGAN DAVIS AKA BRYANNA M DAVIS, et al,**  
Defendant(s).

NOTICE IS HEREBY GIVEN Pursuant to a Final Judgment of Foreclosure dated April 16, 2026, and entered in Case No. 2025 CA 004566 NC of the Circuit Court of the Twelfth Judicial Circuit in and for Sarasota County, Florida in which Carrington Mortgage Services, LLC, is the Plaintiff and Bryanna Morgan Davis aka Bryanna M Davis, Kevin Danial Shahan, Jr. aka Kevin D. Shahan, Jr., United States of America Acting through Secretary of Housing and Urban Development, are defendants, the Sarasota County Clerk of the Circuit Court Karen E. Rushing will sell to the highest and best bidder for cash in/on online at www.sarasota.realforeclose.com, Sarasota County, Florida at 9:00am on the July 15, 2026 the following described property as set forth in said Final Judgment of Foreclosure:

THE FOLLOWING DESCRIBED LAND, SITUATE, LYING AND BEING IN SARASOTA, FLORIDA, TO-WIT:

LOTS 13 AND 14, BLOCK 1504, THIRTIETH ADDITION TO PORT CHARLOTTE SUBDIVISION, ACCORDING TO THE PLAT THEREOF, AS RECORDED IN PLAT BOOK 15, PAGE(S) 14, 14A THROUGH 14Q, OF THE PUBLIC RECORDS OF SARASOTA COUNTY, FLORIDA.  
A/K/A 5981 GALAMBOS ST  
NORTH PORT FL 34291

Any person claiming an interest in the surplus from the sale, if any, other than the property owner as of the date of the Lis Pendens must file a claim before the Clerk reports the surplus as unclaimed.

If you are a person with a disability who needs any accommodation in order to participate in this proceeding, you are entitled, at no cost to you, to the provision of certain assistance. Please contact the Sarasota County Jury Office, P.O. Box 3079, Sarasota, Florida 34230-3079, (941)861-7400, at least seven (7) days before your scheduled court appearance, or immediately upon receiving this notification if the time before the scheduled appearance is less than seven (7) days; if you are hearing or voice impaired, call 711.

Dated this 12 day of June, 2026.  
ALBERTELLI LAW  
P. O. Box 23028  
Tampa, FL 33623  
Tel: (813) 221-4743  
Fax: (813) 221-9171  
eService: servealaw@albertellilaw.com  
By: /s/ Charline Calhoun  
Florida Bar #16141  
IN/25-010914  
June 19, 26, 2026 26-013825

## SECOND INSERTION

**NOTICE OF SALE PURSUANT TO CHAPTER 45**  
IN THE CIRCUIT COURT OF THE 12TH JUDICIAL CIRCUIT, IN AND FOR SARASOTA COUNTY, FLORIDA  
CASE NO.: 2025 CA 001761

**KIAMI FUNDING, INC.,**  
Plaintiff, v.  
**LAUCTION THREE LLC, et al,**  
Defendant(s).

NOTICE IS HEREBY GIVEN that pursuant to a Final Judgment in Foreclosure entered on January 8, 2026 and entered in Case No. 2025 CA 001761 in the Circuit Court of the 12th Judicial Circuit in and for Sarasota County, Florida, wherein LAUCTION THREE LLC, et al., are the Defendants. The Clerk of the Court, KAREN E. RUSHING, will sell to the highest bidder for cash at https://www.sarasota.realforeclose.com on July 17, 2026 at 9:00am, the following described real property as set forth in said Final Judgment, to wit:

LOT 10, BLOCK C, CLARK MEADOWS SUBDIVISION, ACCORDING TO THE MAP OR PLAT THEREOF AS RECORDED IN PLAT BOOK 8, PAGE 111, PUBLIC RECORDS OF SARASOTA COUNTY, FLORIDA.  
and commonly known as: 3801 CLOVER LANE, SARASOTA, FL 34233 (the "Property").

ANY PERSON CLAIMING AN INTEREST IN THE SURPLUS FROM THE SALE, IF ANY, OTHER THAN THE PROPERTY OWNER AS OF THE DATE OF THE LIS PENDENS MUST FILE A CLAIM WITHIN 60

## DAYS AFTER THE SALE.

If you are a person with a disability who needs any accommodation in order to participate in this proceeding, you are entitled, at no cost to you, to the provision of certain assistance. Please contact the Sarasota County Jury Office, P.O. Box 3079, Sarasota, Florida 34230-3079, (941)861-7400, at least seven (7) days before your scheduled court appearance, or immediately upon receiving this notification if the time before the scheduled appearance is less than seven (7) days; if you are hearing or voice impaired, call 711.

GHDOTTI | BERGER LLP  
Attorneys for Plaintiff  
10800 Biscayne Blvd., Suite 201  
Miami, FL 33161  
Telephone: (305) 501-2808  
Facsimile: (954) 780-5578  
By: /s/ Rebecca E. Smith  
Jason Duggar, Esq.  
FL Bar No.: 83813  
Christophal Hellewell, Esq.  
FL Bar No.: 114230  
Anya E. Macias, Esq.  
FL Bar No.: 0458600  
Tara Rosenfeld, Esq.  
FL Bar No.: 59454  
Johanni Fernandez-Marmol, Esq.  
FL Bar No.: 1055042  
Jimmy Edwards, Esq.  
FL Bar No.: 81855  
Rebecca E. Smith, Esq.  
FL Bar No.: 1069865  
Spencer Gollahon, Esq.  
FL Bar No.: 647799  
Paris Roach, Esq.  
FL Bar No.: 1028751  
fcpleadings@ghdottiberger.com  
June 19, 26, 2026 26-013895

## SECOND INSERTION

**NOTICE OF FORECLOSURE SALE PURSUANT TO CHAPTER 45**  
IN THE CIRCUIT COURT OF THE TWELFTH JUDICIAL CIRCUIT IN AND FOR SARASOTA COUNTY, FLORIDA

CASE NO.: 2023 CA 001140  
**WILMINGTON SAVINGS FUND SOCIETY, FSB, NOT IN ITS INDIVIDUAL CAPACITY BUT SOLELY IN ITS CAPACITY AS OWNER TRUSTEE FOR ONITY LOAN ACQUISITION TRUST 2025-HB2,**  
Plaintiff, vs.

**CARLOS COLCAS; UNKNOWN SPOUSE OF CARLOS COLCAS; UNITED STATES OF AMERICA, DEPARTMENT OF HOUSING AND URBAN DEVELOPMENT; UNKNOWN TENANT #1; UNKNOWN TENANT #2,**  
Defendant(s).

NOTICE IS HEREBY GIVEN that sale will be made pursuant to an Order or Final Judgment. Final Judgment was awarded on April 15, 2026 in Civil Case No. 2023 CA 001140, of the Circuit Court of the TWELFTH JUDICIAL CIRCUIT in and for Sarasota County, Florida, wherein, WILMINGTON SAVINGS FUND SOCIETY, FSB, NOT IN ITS INDIVIDUAL CAPACITY BUT SOLELY IN ITS CAPACITY AS OWNER TRUSTEE FOR ONITY LOAN ACQUISITION TRUST 2025-HB2 is the Plaintiff, and CARLOS COLCAS; UNKNOWN SPOUSE OF CARLOS COLCAS; UNITED STATES OF AMERICA, DEPARTMENT OF HOUSING AND URBAN DEVELOPMENT; UNKNOWN TENANT #1; UNKNOWN TENANT #2 are Defendants.

The Clerk of the Court, Karen E. Rushing will sell to the highest bidder

for cash at www.sarasota.realforeclose.com on July 21, 2026 at 09:00:00 AM EST the following described real property as set forth in said Final Judgment, to wit:

LOT 1, BURNSWOOD SUBDIVISION, A SUBDIVISION ACCORDING TO THE PLAT THEREOF, RECORDED IN PLAT BOOK 21, PAGE 9, OF THE PUBLIC RECORDS OF SARASOTA COUNTY, FLORIDA.

Any person claiming an interest in the surplus from the sale, if any, other than the property owner as of the date of the lis pendens must file a claim before the clerk reports the surplus as unclaimed.

If you are a person with a disability who needs any accommodation in order to participate in this proceeding, you are entitled, at no cost to you, to the provision of certain assistance. Please contact the Sarasota County Jury Office, P.O. Box 3079, Sarasota, Florida 34230-3079, (941)861-7400, at least seven (7) days before your scheduled court appearance, or immediately upon receiving this notification if the time before the scheduled appearance is less than seven (7) days; if you are hearing or voice impaired, call 711.

Dated this 12th day of June, 2026.  
ALDRIDGE PITE, LLP  
Attorney for Plaintiff  
401 W. Linton Blvd.  
Suite 202-B  
Delray Beach, FL 33444  
Telephone: 561-392-6391  
Facsimile: 561-392-6965  
By: /s/ Zachary Ullman, Esq.  
FBN: 106751  
Primary E-Mail:  
ServiceMail@aldridgepite.com  
1395-840B  
June 19, 26, 2026 26-013595

## SECOND INSERTION

**NOTICE OF ACTION - CONSTRUCTIVE SERVICE**  
IN THE CIRCUIT COURT OF THE TWELFTH JUDICIAL CIRCUIT IN AND FOR SARASOTA COUNTY, FLORIDA  
GENERAL JURISDICTION DIVISION

CASE NO. 2025 CA 005992 NC  
**ROCKET MORTGAGE, LLC F/K/A RUCKEN LOANS, LLC,**  
Plaintiff, vs.

**THE UNKNOWN HEIRS, BENEFICIARIES, DEVISEES, GRANTEEES, ASSIGNEES, LIENORS, CREDITORS, TRUSTEES AND ALL OTHERS WHO MAY CLAIM AN INTEREST IN THE ESTATE OF FRANCESCO VIGILANTE, DECEASED. et. al.**  
Defendant(s).

TO: MARLENE M. BROWN, whose residence is unknown and all parties having or claiming to have any right, title or interest in the property described in the mortgage being foreclosed herein.

YOU ARE HEREBY NOTIFIED that an action to foreclose a mortgage on the following property:

LOT 8, BLOCK 55, FOURTH ADDITION TO PORT CHARLOTTE SUBDIVISION, ACCORDING TO PLAT THEREOF AS RECORDED IN PLAT BOOK 11, PAGES 32A THROUGH 32H, OF THE PUBLIC RECORDS OF SARASOTA COUNTY, FLORIDA.

has been filed against you and you are required to serve a copy of your writ-

ten defenses, if any, to it on counsel for Plaintiff, whose address is 6409 Congress Avenue, Suite 100, Boca Raton, Florida 33487 on or before July 27, 2026 / (30 days from Date of First Publication of this Notice) and file the original with the clerk of this court either before service on Plaintiff's attorney or immediately thereafter; otherwise a default will be entered against you for the relief demanded in the complaint or petition filed herein.

If you are a person with a disability who needs any accommodation in order to participate in this proceeding, you are entitled, at no cost to you, to the provision of certain assistance. Please contact the Sarasota County Jury Office, P.O. Box 3079, Sarasota, Florida 34230-3079, (941)861-7400, at least seven (7) days before your scheduled court appearance, or immediately upon receiving this notification if the time before the scheduled appearance is less than seven (7) days; if you are hearing or voice impaired, call 711.

WITNESS my hand and the seal of this Court at Sarasota County, Florida, this 8 day of June, 2026.

KAREN E. RUSHING  
CLERK OF THE CIRCUIT COURT  
BY: GLEN KOPINSKY  
DEPUTY CLERK  
Robertson, Anschutz, Schneid, Crane & Partners, PLLC  
6409 Congress Ave., Suite 100  
Boca Raton, FL 33487  
PRIMARY EMAIL: flmail@raslg.com  
25-330399  
June 19, 26, 2026 26-013375

## SECOND INSERTION

**NOTICE OF FORECLOSURE SALE**  
IN THE CIRCUIT COURT OF THE TWELFTH JUDICIAL CIRCUIT IN AND FOR SARASOTA COUNTY, FLORIDA

CASE NO.: 2025-CA-004923  
**U.S. BANK TRUST NATIONAL ASSOCIATION, NOT IN ITS INDIVIDUAL CAPACITY BUT SOLELY AS OWNER TRUSTEE FOR GS MORTGAGE-BACKED SECURITIES TRUST 2022-RPL2,**  
Plaintiff, v.  
**KIM WUYTS, et al.,**  
Defendants.

NOTICE is hereby given that Karen E. Rushing, Clerk of the Circuit Court of Sarasota County, Florida, will on July 14, 2026, at 9:00 a.m. ET, via online auction site at www.sarasota.realforeclose.com in accordance with Chapter 45, E.S., offer for sale and sell to the highest and best bidder for cash, the following described property situated in Sarasota County, Florida, to wit:

Unit 24-103, Phase 24, PARKRIDGE, a Condominium, according to the Declaration of Condominium, as recorded in Official Records Instrument # 2004046838, as amended Official Records # 2005046773 of the Public Records of Sarasota County, Florida.  
Property Address: 3750 Parkridge Circle, Sarasota, FL 34243

pursuant to the Final Judgment of Foreclosure entered in a case pending in said Court, the style and case number of which is set forth above.

Any person claiming an interest in

the surplus from the sale, if any, other than the property owner as of the date of the Lis Pendens must file a claim before the clerk reports the surplus as unclaimed.

If the sale is set aside for any reason, the Purchaser at the sale shall be entitled only to a return of the deposit paid. The Purchaser shall have no further recourse against the Mortgagor, the Mortgagee or the Mortgagee's attorney.

If you are a person with a disability who needs any accommodation in order to participate in this proceeding, you are entitled, at no cost to you, to the provision of certain assistance. Please contact the Sarasota County Jury Office, P.O. Box 3079, Sarasota, Florida 34230-3079, (941)861-7400, at least seven (7) days before your scheduled court appearance, or immediately upon receiving this notification if the time before the scheduled appearance is less than seven (7) days; if you are hearing or voice impaired, call 711.

SUBMITTED on this 10th day of June, 2026.  
TIFFANY & BOSCO, P.A.  
/s/ Kathryn I. Kasper, Esq.  
Anthony R. Smith, Esq.  
FL Bar #157147  
Kathryn I. Kasper, Esq.  
FL Bar #621188  
Attorneys for Plaintiff  
OF COUNSEL:  
Tiffany & Bosco, P.A.  
1201 S. Orlando Ave, Suite 430  
Winter Park, FL 32789  
Telephone: (205) 930-5200  
Facsimile: (407) 712-9201  
June 19, 26, 2026 26-013485

## SECOND INSERTION

**NOTICE OF SALE**  
IN THE CIRCUIT COURT OF THE TWELFTH JUDICIAL CIRCUIT IN AND FOR SARASOTA COUNTY, FLORIDA

CASE NO. 2025 CA 005048 NC  
**WELLS FARGO BANK, N.A.**  
Plaintiff, v.

**THE UNKNOWN HEIRS, GRANTEEES, DEVISEES, LIENORS, TRUSTEES, AND CREDITORS OF JACQUELINE M. SCHLICHTHERNLEIN, DECEASED; UNKNOWN SPOUSE OF JACQUELINE M. SCHLICHTHERNLEIN; UNKNOWN TENANT 1; UNKNOWN TENANT 2; JACQUELINE M. SCHLICHTHERNLEIN AS TRUSTEE OF THE JACQUELINE M. SCHLICHTHERNLEIN LIVING TRUST DATED MARCH 30TH, 2021; DONALD BAESZLER; LYNN BAESZLER BETTS; CACH, LLC; THE UNKNOWN SUCCESSOR TRUSTEE(S) OF THE JACQUELINE M. SCHLICHTHERNLEIN LIVING TRUST DATED MARCH 30TH, 2021**  
Defendants.

Notice is hereby given that, pursuant to the Final Judgment of Foreclosure entered on May 28, 2026, in this case, in the Circuit Court of Sarasota County, Florida, the office of Karen E. Rushing, Clerk of the Circuit Court, shall sell the property situated in Sarasota County, Florida, described as:

UNIT 3281-101, VILLAGE BROOKE CONDOMINIUM III, ACCORDING TO THE DECLARATION OF CONDOMINIUM RECORDED IN OFFICIAL RECORDS BOOK 1262, PAGES 1681 THRU 1753,

AS AMENDED, AND AS PER PLAT THEREOF RECORDED IN CONDOMINIUM BOOK 11, PAGE 27, 27A THRU 27D, PUBLIC RECORDS OF SARASOTA COUNTY, FLORIDA.

a/k/a 3281 BENEVA RD UNIT 101, SARASOTA, FL 34232-4545

at public sale, to the highest and best bidder, for cash, online at www.sarasota.realforeclose.com, on July 02, 2026 beginning at 09:00 AM.

Any person claiming an interest in the surplus from the sale, if any, other than the property owner as of the date of the lis pendens must file a claim before the clerk reports the surplus as unclaimed.

If you are a person with a disability who needs any accommodation in order to participate in this proceeding, you are entitled, at no cost to you, to the provision of certain assistance. Please contact the Sarasota County Jury Office, P.O. Box 3079, Sarasota, Florida 34230-3079, (941)861-7400, at least seven (7) days before your scheduled court appearance, or immediately upon receiving this notification if the time before the scheduled appearance is less than seven (7) days; if you are hearing or voice impaired, call 711.

Dated at St. Petersburg, Florida this 5 day of June, 2026.  
eXL Legal, PLLC  
Designated Email Address:  
efiling@exllegal.com  
12425 28th Street North, Suite 200  
St. Petersburg, FL 33716  
Telephone No. (727) 536-4911  
Attorney for the Plaintiff  
/s/ Peter E. Lanning  
Peter E. Lanning  
FL Bar: 562221  
1000011157  
June 19, 26, 2026 26-013475

## SECOND INSERTION

**NOTICE OF FORECLOSURE SALE**  
IN THE CIRCUIT COURT OF THE 12TH JUDICIAL CIRCUIT IN AND FOR SARASOTA COUNTY, FLORIDA

CASE NO.: 2026 CA 000442 NC  
**KIAMI FUNDING, INC.,**  
Plaintiff, v.  
**OPULENT HOMES LLC, A DELAWARE LIMITED LIABILITY COMPANY; CITY OF SARASOTA, FLORIDA; UNKNOWN TENANT #1; UNKNOWN TENANT #2,**  
Defendants.

NOTICE IS HEREBY GIVEN pursuant to a Final Judgment dated May 27, 2026 entered in Civil Case No. 2026 CA 000442 NC in the Circuit Court of the 12th Judicial Circuit in and for Sarasota County, Florida, wherein KIAM FUNDING, INC., Plaintiff and OPULENT HOMES LLC, A DELAWARE LIMITED LIABILITY COMPANY; CITY OF SARASOTA, FLORIDA are defendants, Karen E. Rushing, Clerk of Court, will sell the property at public sale at www.sarasota.realforeclose.com beginning at 9:00 AM on July 14, 2026 the following described property as set forth in said Final Judgment, to-wit-:

LOT 7, LOMA LINDA PARK, AS PER PLAT THEREOF RECORDED IN PLAT BOOK 5, PAGE 38, OF THE PUBLIC RECORDS OF SARASOTA COUNTY, FLORIDA.  
Property Address: 2370 Bahua Vista St, Sarasota, FL 34239

ANY PERSON CLAIMING AN INTEREST IN THE SURPLUS FROM THE SALE, IF ANY, OTHER THAN THE PROPERTY OWNER AS OF THE DATE OF THE LIS PENDENS MUST FILE A CLAIM BEFORE THE CLERK REPORTS THE SURPLUS AS UNCLAIMED.

THE COURT, IN ITS DISCRETION, MAY ENLARGE THE TIME OF THE SALE. NOTICE OF THE CHANGED TIME OF SALE SHALL BE PUBLISHED AS PROVIDED HEREIN.

If you are a person with a disability who needs any accommodation in order to participate in this proceeding, you are entitled, at no cost to you, to the provision of certain assistance. Please contact the Sarasota County Jury Office, P.O. Box 3079, Sarasota, Florida 34230-3079, (941)861-7400, at least seven (7) days before your scheduled court appearance, or immediately upon receiving this notification if the time before the scheduled appearance is less than seven (7) days; if you are hearing or voice impaired, call 711.

Kelley Kronenberg  
10360 West State Road 84  
Fort Lauderdale, FL 33324  
Phone: (954) 370-9970  
Fax: (954) 252-4571  
Service E-mail:  
flrealprop@kelleykronenberg.com  
/s/ Barron A. Becker  
Barron A. Becker, Esq.  
FBN: 1031460  
File No: 3843.000271  
June 19, 26, 2026 26-013835

## SECOND INSERTION

**NOTICE OF FORECLOSURE SALE**  
IN THE COUNTY COURT OF THE TWELFTH JUDICIAL CIRCUIT IN AND FOR SARASOTA COUNTY, FLORIDA

CIVIL DIVISION  
Case No.: 25CC003727SC

**JOCKEY CLUB OF NORTH PORT PROPERTY OWNERS' ASSOCIATION, INC., a Florida not-for-profit corporation,**  
Plaintiff, vs.

**MARY LEE CROWLEY; her devisees, grantees, creditors, and all other parties claiming by, through, under or against him and all unknown natural persons, if alive and if not known to be dead or alive, their several and respective spouses, heirs, devisees grantees, and creditors or other parties claiming by, through, or under those unknown natural persons and their several unknown assigns, successors in interest trustees, or any other persons claiming by through, under or against any corporation or other legal entity named as a defendant and all claimants, persons or parties natural or corporate whose exact status is unknown, claiming under any of the above named or described defendants or parties who are claiming to have any right, title or interest in and to the lands hereafter described; UNKNOWN SPOUSE OF MARY LEE CROWLEY; CITY OF NORTH PORT, FLORIDA; RENEW FINANCIAL GROUP, LLC; UNKNOWN TENANT #1; and UNKNOWN TENANT #2,**  
Defendants.

NOTICE IS HEREBY GIVEN that I, the undersigned Clerk of the Circuit Court of Sarasota County, Florida, will at 9:00 a.m. on the 8th day of July, 2026, at public sale at www.sarasota.realforeclose.com, sell to the highest bidder, for cash, the following-described real property:

Lot 16, Block 2629, 52nd Addition to PORT CHARLOTTE SUBDIVISION, a Subdivision according to the Plat thereof as recorded in Plat Book 21, Pages 13-13NN, of Public Records of Sarasota County, Florida.

The said sale will be made pursuant to the Final Judgment of Foreclosure of the Circuit Court of Sarasota County, Florida, in Civil Action No. 25CC003727SC.

Any person claiming an interest in the surplus from the sale, if any, other than the property owner as of the date of the Lis pendens must file a claim within 60 days after the sale.

If you are a person with a disability who needs any accommodation in order to participate in this proceeding, you are entitled, at no cost to you, to the provision of certain assistance. Please contact the Sarasota County Jury Office, P.O. Box 3079, Sarasota, Florida 34230-3079, (941)861-7400, at least seven (7) days before your scheduled court appearance, or immediately upon receiving this notification if the time before the scheduled appearance is less than seven (7) days; if you are hearing or voice impaired, call 711.

KAREN E. RUSHING,  
Clerk of Court  
June 19, 26, 2026 26-013465

## SECOND INSERTION

**NOTICE OF ACTION - CONSTRUCTIVE SERVICE**  
IN THE CIRCUIT COURT OF THE TWELFTH JUDICIAL CIRCUIT IN AND FOR SARASOTA COUNTY, FLORIDA  
GENERAL JURISDICTION DIVISION

CASE NO. 2026 CA 002506 NC  
**WILMINGTON SAVINGS FUND SOCIETY, FSB, NOT INDIVIDUALLY BUT SOLELY AS TRUSTEE FOR FINANCE OF AMERICA STRUCTURED SECURITIES ACQUISITION TRUST 2025-HB1,**  
Plaintiff, vs.

**THE UNKNOWN HEIRS, BENEFICIARIES, DEVISEES, GRANTEEES, ASSIGNEES, LIENORS, CREDITORS, TRUSTEES AND ALL OTHERS WHO MAY CLAIM AN INTEREST IN THE ESTATE OF BARBARA ANN CURRAN A/K/A BARBARA HUSCHLE, DECEASED, et. al.**  
Defendant(s).

TO: THE UNKNOWN HEIRS, BENEFICIARIES, DEVISEES, GRANTEEES, ASSIGNEES, LIENORS, CREDITORS, TRUSTEES AND ALL OTHERS WHO MAY CLAIM AN INTEREST IN THE ESTATE OF BARBARA ANN CURRAN A/K/A BARBARA A. HUSCHLE, DECEASED,

whose residence is unknown if he/she/they be living; and if he/she/they be dead, the unknown defendants who may be spouses, heirs, devisees, grantees, assignees, lienors, creditors, trustees, and all parties claiming an interest by, through, under or against the Defendants, who are not known to be dead or alive, and all parties having or claiming to have any right, title or interest in the property described in the mortgage being foreclosed herein.

YOU ARE HEREBY NOTIFIED that an action to foreclose a mortgage on the following property:

LOT 105, UNIT NO. 7 SIESTA ISLES, ACCORDING TO THE MAP OR PLAT THEREOF, AS RECORDED IN PLAT BOOK 13, PAGE(S) 20, OF THE PUBLIC RECORDS OF SARASOTA COUNTY, FLORIDA.

has been filed against you and you are required to serve a copy of your written defenses, if any, to it on counsel for Plaintiff, whose address is 6409 Congress Ave., Suite 100, Boca Raton, Florida 33487 on or before July 20, 2026 / (30 days from Date of First Publication of this Notice) and file the original with the clerk of this court either before service on Plaintiff's attorney or immediately thereafter; otherwise a default will be entered against you for the relief demanded in the complaint or petition filed herein.

If you are a person with a disability who needs any accommodation in order to participate in this proceeding, you are entitled, at no cost to you, to the provision of certain assistance. Please contact the Sarasota County Jury Office, P.O. Box 3079, Sarasota, Florida 34230-3079, (941)861-7400, at least seven (7) days before your scheduled court appearance, or immediately upon receiving this notification if the time before the scheduled appearance is less than seven (7) days; if you are hearing or voice impaired, call 711.

WITNESS my hand and the seal of this Court at Sarasota County, Florida, this 11 day of June, 2026.

KAREN E. RUSHING  
CLERK OF THE CIRCUIT COURT  
BY: GLEN KOPINSKY  
DEPUTY CLERK  
ROBERTSON, ANSCHUTZ, AND SCHNEID, PL  
ATTORNEY FOR PLAINTIFF  
6409 Congress Ave., Suite 100  
Boca Raton, FL 33487  
PRIMARY EMAIL: flmail@raslg.com  
26-406207  
June 19, 26, 2026 26-013565

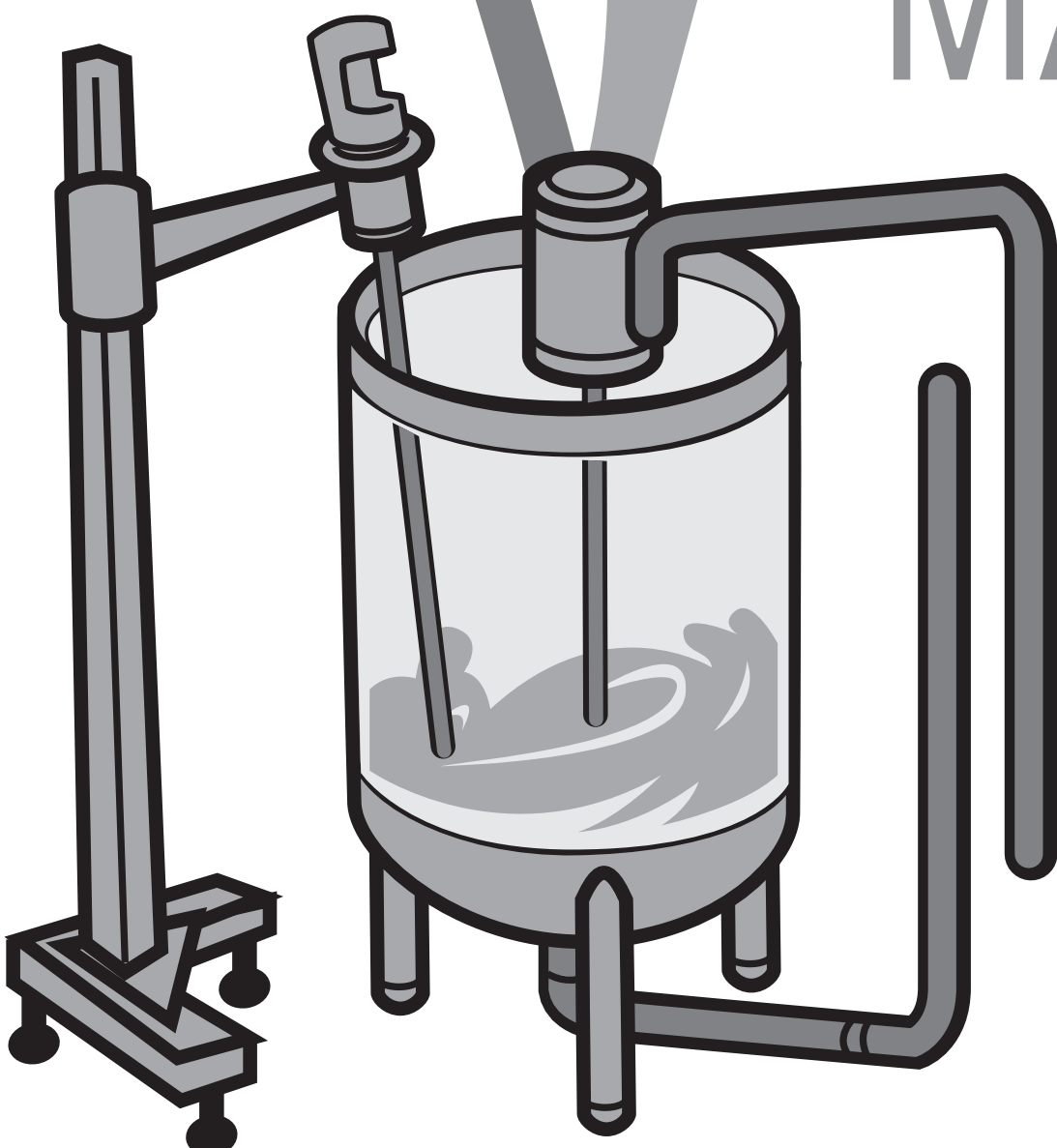
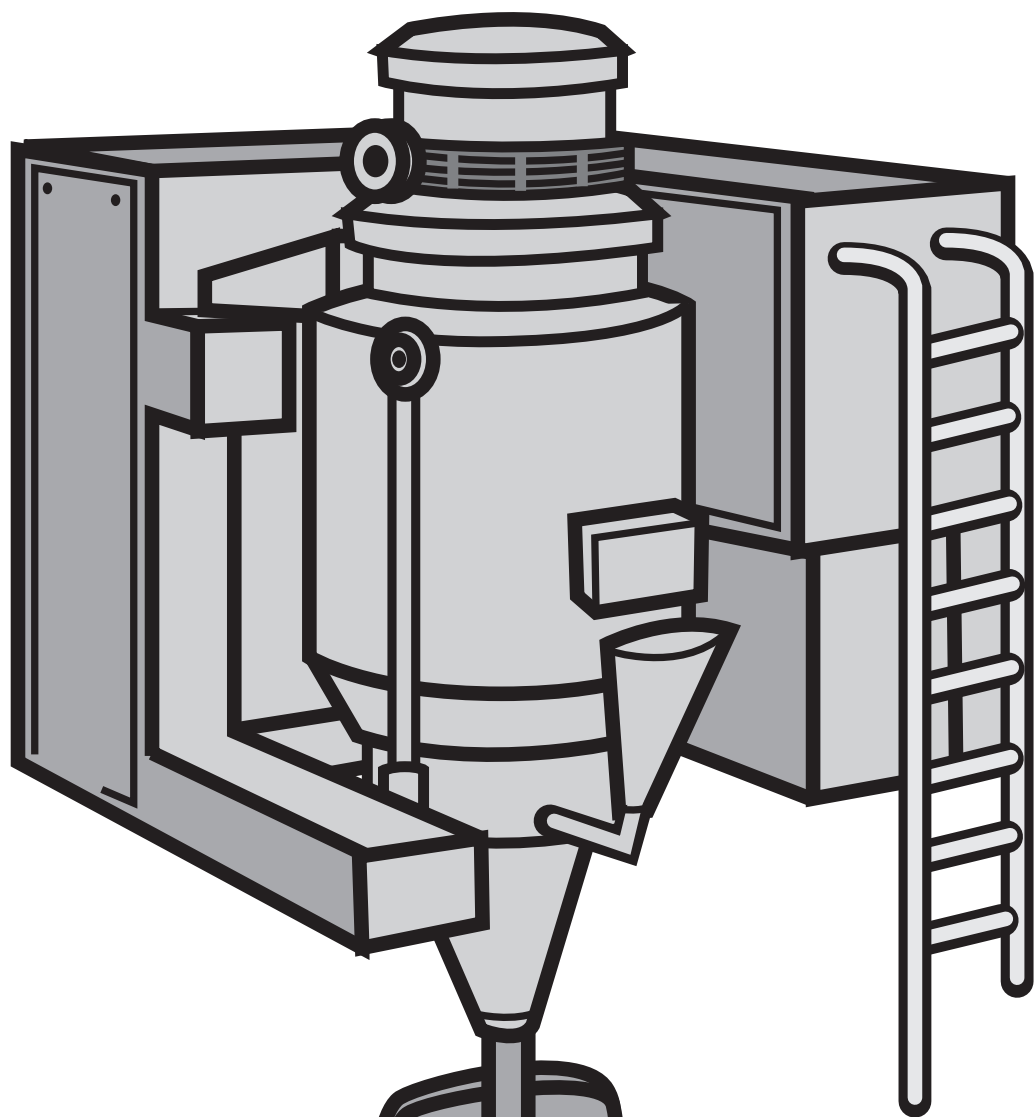

A special printing of a classic story illustrating the importance of protecting capitalism.

# TOM SMITH AND HIS INCREDIBLE BREAD MACHINE

**By R.W. Grant**

Illustrations by Austin McKinley

This is the legend of a man whose name  
Was a household word: a man whose fame  
Burst on the world like an atom bomb.  
Smith was his last name; first name: Tom.

The argument goes on today.  
"He was a villain," some will say.  
"No! A hero!" others declare.  
Or was he both? Well, I despair;  
The fight will last 'til kingdom come;  
Was Smith a hero? Or was Smith a bum?  
So, listen to the story and it's up to you  
To decide for yourself as to which is true!

Now, Smith, an inventor, had specialized  
In toys. So people were surprised  
When they found that he instead  
Of making toys, was baking bread!  
The news was flashed by CBS  
Of his incredible success.  
Then NBC jumped in in force,  
Followed by the Times, of course.  
The reason for their rapt attention,  
The nature of his new invention,  
The way to make bread he'd conceived  
Cost less than people could believe!  
And not just make it! This device  
Could in addition wrap and slice!  
The price per loaf, one loaf or many:  
The miniscule sum of under one penny!

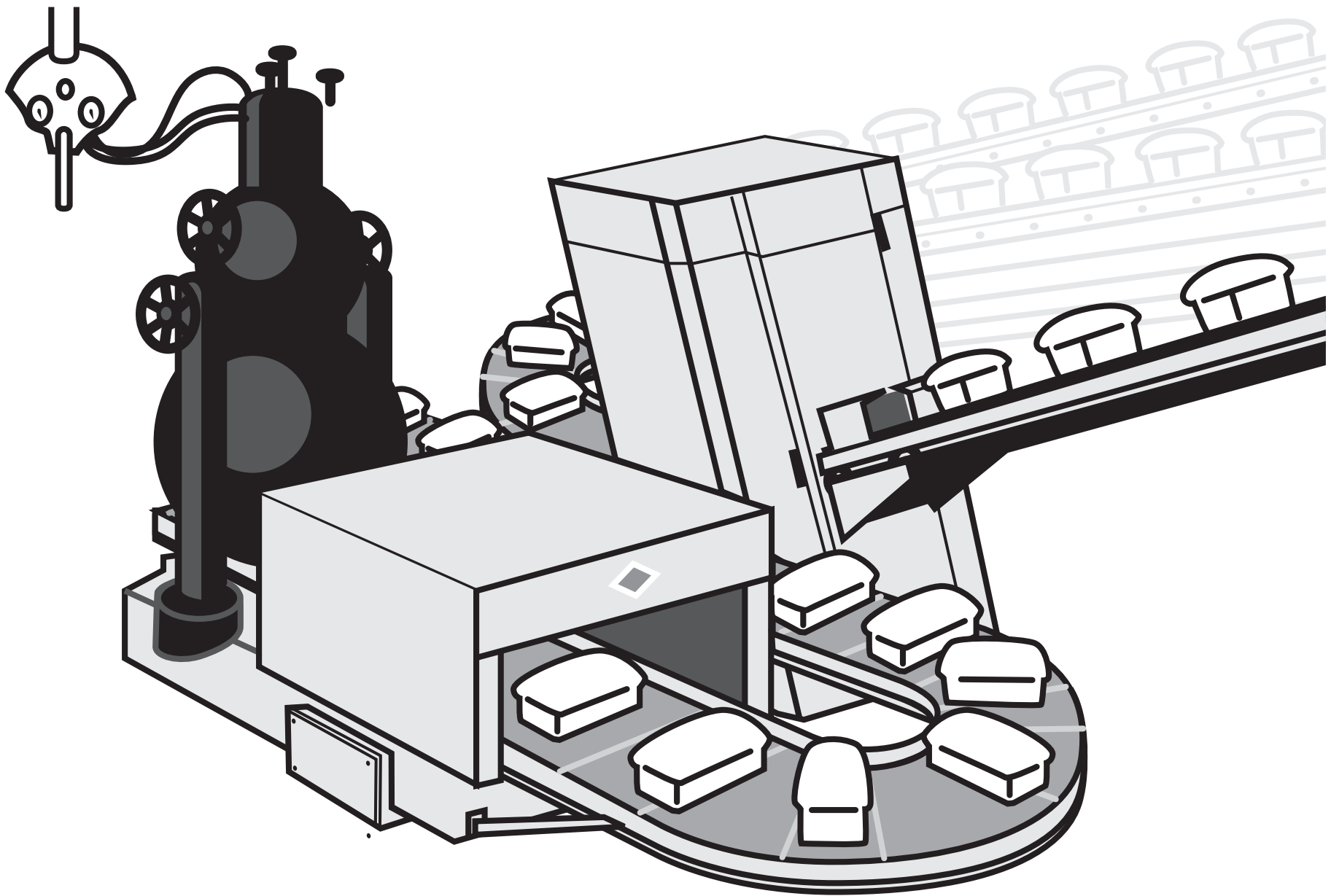

Can you imagine what this meant?  
Can you comprehend the consequent?  
The first time yet the world well fed!  
And all because of Tom Smith's bread!

Not the last to see the repercussions  
Were the Red Chinese, and, of course, the  
Russians,  
For Capitalist bread in such array

Threw the whole red block into black dis-  
may!  
Nonetheless, the world soon found  
That bread was plentiful the world  
around.  
Thanks to Smith and all that bread,  
A grateful world was at last well fed!

But isn't it a wondrous thing  
How quickly fame is flown?  
Smith, the hero of today  
Tomorrow, scarcely known!  
Yes, the fickle years passed by.  
Smith was a billionaire.

But Smith himself was now forgot,  
Though bread was everywhere.  
People, asked from where it came,  
Would very seldom know.

They would simply eat and ask,  
'Was not it always so?'

However, Smith cared not a bit,  
For millions ate his bread,  
And "Everything is fine," thought he.  
"I'm rich and they are fed!"

Everything was fine, he thought?  
He reckoned not with fate.  
Note the sequence of events  
Starting on the date  
On which inflation took its toll,  
And to a slight extent,  
The price on every loaf increased:  
It went to one full cent!

A sharp reaction quickly came.  
People were concerned.  
White House aide expressed dismay.  
Then the nation learned  
That Russia lodged a sharp protest.  
India did the same.  
"Exploitation of the Poor!"  
Yet, who was there to blame?

And though the clamor ebbed and flowed,  
All that Tom would say  
Was that it was but foolish talk.  
Which soon would die away.  
And it appeared that he was right.  
Though on and on it ran,  
The argument went 'round and 'round  
But stopped where it began.

There it stopped, and people cried,  
"For heaven's sake, we can't decide!  
It's relative! Beyond dispute,  
There's no such thing as 'absolute'!  
And though we try with all our might,  
Since nothing's ever black or white,  
All that we can finally say is  
'Everything one shade of grey is!'  
So people cried out, "Give us light!  
We can't tell what's wrong from right!"

To comprehend confusion,  
We seek wisdom at its source.  
To whom, then did the people turn?  
The Intellectuals, of course!

And what could be a better time  
For them to take the lead,  
Than at their International Conference  
On Inhumanity and Greed.  
For at this weighty conference,  
Once each year we face  
The moral conscience of the world—  
Concentrated in one place.

At that mighty conference were  
A thousand, more or less,  
Of intellectuals and bureaucrats,  
And those who write the press.  
And from Yale and Harvard  
The professors; all aware  
The fate of Smith would now be known.  
Excitement filled the air!

"The time has come," the chairman said  
"To speak of many things:  
Of duty, bread and selfishness,  
And the evil that it brings.  
For, speaking thus we can amend  
That irony of fate  
That gives to unenlightened minds  
The power to create.



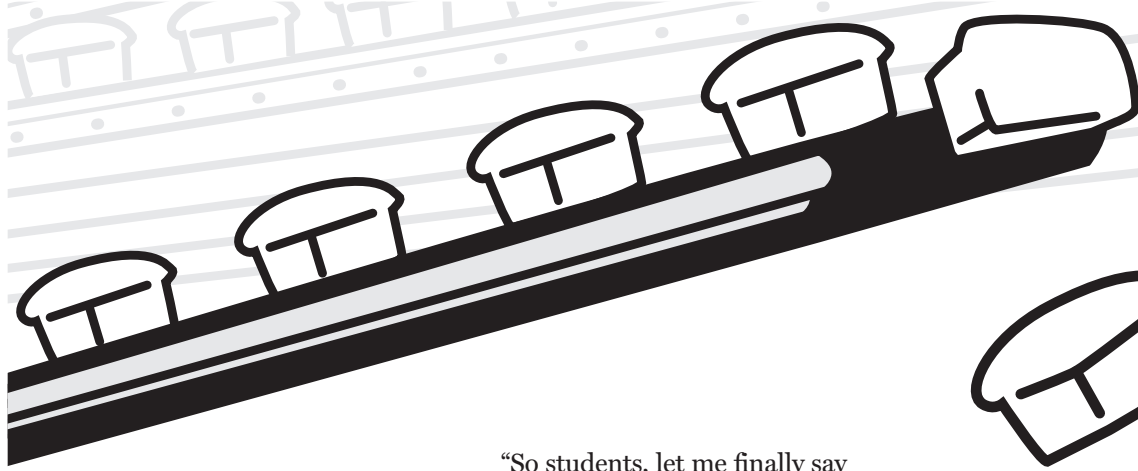

“Since reason tells us that it can’t,  
Therefore let us start  
Not by thinking with the mind,  
But only with the heart!  
Since we believe in people, then,”  
At last the chairman said,  
“We must meet our obligation  
To see that they are fed!”

And so it went, one by one,  
Denouncing private greed;  
Denouncing those who’d profit thus  
From other people’s need!

Then, suddenly each breath was held,  
For there was none more wise  
Than the nation’s foremost Pundit  
Who now rose to summarize:

“My friends,” he said, (they all  
exhaled)  
“We see in these events  
The flouting of the Higher Law—  
And its consequence.  
We must again remind ourselves  
Just why mankind is cursed:  
Because we fail to realize  
Society comes first!

“Smith placed himself above the  
group  
To profit from his brothers.  
He failed to see the Greater Good,  
Is Service, friends, to Others!”

With boldness and with vision,  
then,  
They ratified the motion  
To dedicate to all mankind  
Smith’s bread-and their devotion!

The conference finally ended.  
It had been a huge success.  
The intellectuals had spoken.  
Now others did the rest.

The professors joined in all the  
fuss,  
And one was heard to lecture thus:  
(For clarity, he spoke in terms  
Of Mother Nature, birds and worms):

“That early birds should get the worm  
Is clearly quite unfair.  
Wouldn’t it much nicer be  
If all of them would share?  
But selfishness and private greed

Seem part of nature’s plan,  
Which Mother Nature has decreed  
For bird. But also Man?  
The system which I question now,  
As you are well aware,  
(I’m sure you’ve heard the term  
before  
Is Business, Laissez-Faire!

“So students, let me finally say  
That we must find a nobler way.  
So, let us fix the race that all  
May finish side-by-side;  
The playing field forever flat,  
The score forever tied.  
To achieve this end, of course,  
We turn to government-and force.  
So, if we have to bring Smith do  
As indeed we should,  
I’m sure you will agree with me,  
It’s for the Greater Good!”

Comments in the nation’s press  
Now scorned Smith and his plunder:  
“What right had he to get so rich  
On other people’s hunger?”  
A prize cartoon depicted Smith  
With fat and drooping jowls  
Snatching bread from hungry babes,  
Indifferent to their howls.

One night, a TV star cried out,  
“Forgive me if I stumble,  
But I don’t think, I kid you not,  
That Smith is very humble!”  
Growing bolder, he leaped up,

(Silencing the cheers)  
“Humility!” he cried to all—  
And then collapsed in tears!

The clamor rises all about;  
Now hear the politician shout:  
“What’s Smith done, so rich to be?  
Why should Smith have more than thee?  
So, down with Smith and all his greed;  
I’ll protect your right to need!”

Then Tom found to his dismay  
That certain businessmen would say,  
“The people now should realize  
It’s time to cut Smith down to size,  
For he’s betrayed his public trust  
(And taken all that bread from us!)”

Well, since the Public does come first,  
It could not be denied  
That in matters such as this,  
The public must decide.  
So, SEC became concerned,  
And told the press what it had learned:  
“It’s obvious that he’s guilty  
—Of what we’re not aware—  
Though actually and factually  
We’re sure there’s something there!”

And Antitrust now took a hand.  
Of course it was appalled  
At what it found was going on.  
The “bread trust” it was called.

“Smith has too much crust,”  
they said. “A deplorable condition  
That Robber Barons profit thus  
From cutthroat competition!”

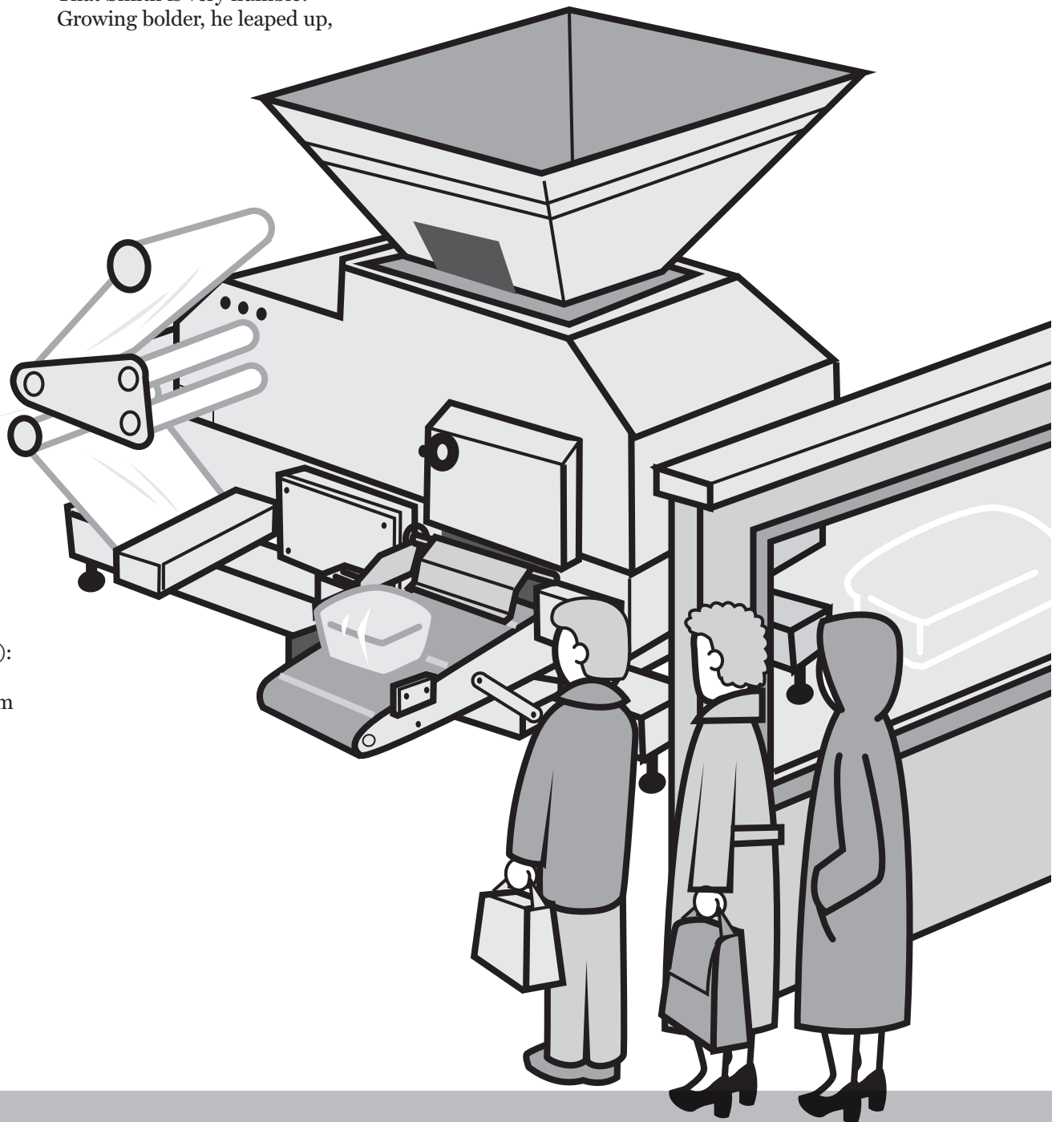

WELL!

This was getting serious!  
So Smith felt that he must  
Have a friendly interview  
With SEC and "Trust."  
So, hat in hand, he went to them.  
They'd surely been misled;  
No rule of law had he defied.  
But then their lawyer said:

"The rule of law, in complex times,  
Has proved itself deficient.  
We much prefer the rule of men.  
It's vastly more efficient.

"So, nutshell-wise, the way it is,  
The law is what we say it is!

"So, let me state the present rules,"  
The lawyer then went on,  
"These very simple guidelines  
You can rely upon:  
You're gouging on your prices  
If you charge more than the rest.  
But it's unfair competition  
If you think you can charge less!  
"A second point that we would make,  
To help avoid confusion:  
Don't try to charge the same amount,  
For that would be collusion!

"You must compete—but not too much.  
For if you do, you see,  
Then the market would be yours—  
And that's monopoly!  
Oh, don't dare monopolize!  
We'd raise an awful fuss,  
For that's the greatest crime of all!  
(Unless it's done by us!)"

"I think I understand," said Tom.  
"And yet, before I go,  
How does one get a job like yours?  
I'd really like to know!"

The lawyer rose then with a smile;  
"I'm glad you asked," said he.  
"I'll tell you how I got my start  
And how it came to be."

(His secretaries gathered 'round  
As their boss did thus expound.)

*"When I was a lad going off to school,  
I was always guided by this golden rule:  
Let others take the lead in things, for  
heaven's sake,  
So if things go wrong—why, then it's their  
mistake!"*  
(*So if things go wrong—why, then it's their  
mistake!*)

*"Following this precept it came to pass  
I became the president of my senior class.  
Then on to college where my profs extolled  
The very same theory from the very same  
mold!"*  
(*The very same theory from the very same  
mold!*)

*"Let others take the chances, and I would  
go along.  
Then I would let them know where they all  
went wrong!  
So successful was my system that then  
indeed,  
I was voted most likely in my class to suc-  
ceed!"*

*(He was voted most likely in his class to  
succeed!)*

*"Then out into the world I went, along  
with all the rest,  
Where I put my golden rule to the ulti-  
mate test.  
I avoided all of commerce at whatever the  
cost—  
And because I never ventured, then I also  
never lost!"*  
(*And because he never ventured, then he  
also never lost!*)

*"With this unblemished record then, I  
quickly caught the eye  
Of some influential people 'mongst the  
powers on high.*

*And so these many years among the  
mighty I have sat,  
Having found my niche as a bureaucrat!"*  
(*Having found his niche as a bureaucrat'*)

*"To be a merchant prince has never been  
my goal,  
For I'm qualified to play a more impor-  
tant role:  
Since I've never failed in business, this of  
course assures  
That I'm qualified beyond dispute to now  
run yours!"*  
(*That he's qualified beyond dispute to now  
run yours!*)

"Thanks; that clears it up," said Tom.

The lawyer said, "I'm glad!  
We try to serve the public good.  
We're really not so bad!

"Now, in disposing of this case,  
If you wish to know just how,  
Go up to the seventh floor;  
We're finalizing now!"

So, Tom went to the conference room  
Up on the seventh floor.  
He raised his hand, about to knock,  
He raised it—but no more—  
For what he overheard within  
Kept him outside the door!  
A sentence here, a sentence there—  
Every other word—  
He couldn't make it out (he hoped),  
For this is what he heard:

"Mumble, mumble, let's not fumble!  
Mumble, mumble, what's the charge?  
Grumble, grumble, he's not humble?  
Private greed? Or good of all?"

"Public Interest, Rah! Rah! Rah!  
Business, Business, Bah! Bah! Bah!

"Say, now this now we confess  
That now this now is a mess!  
Well now, what now do we guess?  
Discharge? Which charge would be best?"

"How 'bout 'Greed and Selfishness'?  
Oh, wouldn't that be fun?  
It's vague enough to trip him up  
No matter what he's done!

"We don't produce or build a thing!  
But before we're through,  
We allow that now we'll show Smith how  
We handle those who do!

"We serve the public interest;  
We make up our own laws;  
Oh, golly gee, how selflessly  
We serve the public cause!

"For we're the ones who make the rules  
At 'Trust and SEC,  
So bye and bye we'll get that guy;  
Now, what charge will it be?

"Price too high? Or price too low?  
Now, which charge will we make?  
Well, we're not loath to charging both  
When public good's at stake!

"But can we go one better?  
How 'bout monopoly?  
No muss, no fuss, oh clever us!  
Right-O! Let's charge all three!

"But why stop here? We have one more!  
Insider Trading! Number four!  
We've not troubled to define  
This crime in any way so,  
This allows the courts to find  
Him guilty 'cause we say so!"

So, that was the indictment.  
Smith's trial soon began.  
It was a cause célèbre  
Which was followed' cross the land.  
In his defense Tom only said,  
"I'm rich, but all of you are fed!  
Is that bargain so unjust  
That I should now be punished thus?"

Tom fought it hard all the way.  
But it didn't help him win.  
The jury took but half an hour  
To bring this verdict in:

"Guilty! Guilty! We agree!  
He's guilty of this plunder!  
He had no right to get so rich  
On other people's hunger!"

"Five years in jail!" the judge then said.  
"You're lucky it's not worse!  
Robber Barons must be taught  
Society Comes First!  
As flies to wanton boys," he leered,  
"Are we to men like these!  
They exploit us for their sport!  
Exploit us as they please!"

The sentence seemed a bit severe,  
But mercy was extended.  
In deference to his mother's pleas,  
One year was suspended.  
And what about the Bread Machine?  
Tom Smith's little friend?  
Broken up and sold for scrap.  
Some win. Some lose. The end.

## EPILOGUE

Now, bread is baked by government.  
And as might be expected,  
Everything is well controlled—  
The public well protected.

True, loaves cost ten dollars each.  
But our leaders do their best.  
The selling price is half a cent.  
Taxes pay the rest!

